

**A manual of practical medical electricity : the Röntgen rays, Finsen light, radium and its radiations and high-frequency currents / by Dawson Turner.**

Dawson, Turner, 1857-1928.

New York : William Wood & Co., 1904.

<http://hdl.handle.net/2027/uc1.b5252332>

# HathiTrust



[www.hathitrust.org](http://www.hathitrust.org)

**Public Domain, Google-digitized**

[http://www.hathitrust.org/access\\_use#pd-google](http://www.hathitrust.org/access_use#pd-google)

We have determined this work to be in the public domain, meaning that it is not subject to copyright. Users are free to copy, use, and redistribute the work in part or in whole. It is possible that current copyright holders, heirs or the estate of the authors of individual portions of the work, such as illustrations or photographs, assert copyrights over these portions. Depending on the nature of subsequent use that is made, additional rights may need to be obtained independently of anything we can address. The digital images and OCR of this work were produced by Google, Inc. (indicated by a watermark on each page in the PageTurner). Google requests that the images and OCR not be re-hosted, redistributed or used commercially. The images are provided for educational, scholarly, non-commercial purposes.





**LIBRARY**  
**OF THE**  
**DENTAL DEPARTMENT,**  
**UNIVERSITY OF CALIFORNIA.**

**This book must be returned within four days. Fine, five cents each day for further detention.**







A MANUAL  
OF  
PRACTICAL MEDICAL ELECTRICITY  
THE RÖNTGEN RAYS, FINSEN LIGHT  
RADIUM AND ITS RADIATIONS  
AND  
HIGH-FREQUENCY CURRENTS



A MANUAL  
OF  
PRACTICAL  
MEDICAL ELECTRICITY

THE RÖNTGEN RAYS, FINSEN LIGHT,  
RADIUM AND ITS RADIATIONS

AND  
HIGH-FREQUENCY CURRENTS

BY  
DAWSON TURNER, B.A., M.D., F.R.C.P. ED.  
// M.R.C.P. LOND.

PRESIDENT OF THE ROYAL SCOTTISH SOCIETY OF ARTS; VICE-PRESIDENT OF THE BRITISH  
ELECTRO-THERAPEUTIC SOCIETY; FELLOW OF THE PHYSICAL SOCIETY; LECTURER  
ON EXPERIMENTAL PHYSICS, SURGEONS' HALL, EDINBURGH; ADDITIONAL EXAMINER  
IN EXPERIMENTAL PHYSICS TO THE EDINBURGH UNIVERSITY; MEDICAL OFFICER  
IN CHARGE OF THE ELECTRICAL DEPARTMENT OF THE ROYAL INFIRMARY,  
EDINBURGH

FOURTH EDITION

REVISED AND ENLARGED

NEW YORK  
WILLIAM WOOD & COMPANY

MDCCCCIV

R



Accession No. 422

RM871  
T94  
1904  
copy 2

654

## PREFACE TO THE FOURTH EDITION

MORE attention has been paid in this edition to the use of sinusoidal currents in treatment, and to the employment of the multiplate static machine in Röntgen-ray work. Part VI. has been rearranged and expanded, and a section on the radiations of radium and their mode of application has been added. The physics, physiological effects, and therapeutic uses of high-frequency currents have been collected together, and are dealt with at greater length in a separate chapter. More than thirty fresh illustrations have been added, and the whole book has been carefully revised. The foundation of the Electro-therapeutic Society and the increasing interest that the medical profession is taking in medical electricity lead one to hope that the tide of unqualified electrical practice will at last be stemmed, and that practitioners will awake to the fact that it is both derogatory to themselves and injurious alike to their profession and to their patients to call in instrument-makers for radiography and nurses and masseurs for electro-therapeutic treatment.

EDINBURGH,  
*July, 1904.*





## PREFACE TO THE THIRD EDITION

THE whole of the first and second editions of this work being out of print, my publishers have requested me to prepare a third edition, and I do this all the more willingly because of the great advance which has recently been made in the treatment of disease by the Röntgen rays and Finsen light. Several new chapters dealing with this important subject have been added, and the nature, production, and use of the Finsen or ultra-violet light has been considered at some length. The earlier portions of the book have been carefully revised and brought up to date; the apparatus for use with the mains and the charging of accumulators in private houses has received more attention; new matter has been added to the chapter on electrolysis; the electrical resistance of the blood is considered in the chapter on electro-diagnosis. I am again indebted to Dr. R. Milne Murray for some remarks upon the Apostoli treatment, and to Mr. David Wallace, F.R.C.S. Ed., for revising and rewriting the chapter on the cystoscope. I also wish to acknowledge the assistance I have had from Dr. Hope Fowler, assistant-physician in the electrical department, in the treatment of many of the cases, and in preparing them for publication.

EDINBURGH,  
*March, 1902.*



# CONTENTS

## INTRODUCTION

	PAGES
Forms of electricity : Static, Galvanic, Faradic—Their characters differ only in degree—Only one kind of electricity -	1—2

## PART I

### *ELECTRO-PHYSICS*

#### CHAPTER I

##### STATIC OR FRICTIONAL ELECTRICITY

Simple static phenomena—The electroscope—Leyden jar—Conductors—Electrical machines : Holtz, Wimshurst, Bonetti, Gaiffe ; care of ; method of application—How to distinguish polarity - - - -	3—16
--	------

#### CHAPTER II

##### MAGNETISM

Natural, artificial, permanent, and temporary magnets—Coercive force — Electro-magnet — Lines of force—Properties of a magnet—Ferro-magnetics, Paramagnetics, Diamagnetics—Resemblance to static electricity - - - - -	17—21
--	-------

#### CHAPTER III

##### GALVANIC ELECTRICITY

Essentials of a galvanic cell—Volta's law—Effects of a current—Polarization—Electrical terms—Positive and negative plates and poles—The volt, ampère, ohm, and coulomb—Ohm's law—The Watt—Comparison between electrical and mechanical power—Continuous, interrupted, and alternating currents - - -	22—33
--	-------



## CHAPTER IV

## FORMS OF PRIMARY CELLS

	PAGES
Single fluid and double fluid—Polarization—Description of the Smee, Leclanché, bichromate of potash, persulphate of mercury, Obach, and Hellesen cells—Double fluid cells—The Daniell, Grove, and Bunsen cells	- 34—52

## CHAPTER V

## ELECTROMOTIVE FORCE AND RESISTANCE

Analogy to water—How to increase the E. M. F.—Series arrangement—Measurement of E. M. F.—Resistance—Laws governing the resistance—Specific resistance—The resistance of fluids—Table of resistance of fluids—Resistance of the body—Measurement of resistance—Summary of the considerations governing the resistance of the body	- - - - - 53—65
--	-----------------

## CHAPTER VI

## CURRENT-STRENGTH

The water analogy—How to increase the current-strength—Best arrangement of cells—Galvanization—Cautery work—Multiple arc—Electrolysis—Lighting purposes—Recapitulation of the uses and of the arrangement of the various cells for different purposes	- - - 66—77
---	-------------

## CHAPTER VII

## MEASUREMENT OF CURRENT-STRENGTH

The voltametric method—The galvanometric method—Action of the electric current on a magnetic needle—Ampère's rule—Tangent and sine galvanometers—Astatic needles—Mirror galvanometer—Calibration—Shunts and divided circuits—Medical galvanometers: Edelmann's, D'Arsonval's, Hot wire instruments—Necessity of a galvanometer	- - - 78—91
--	-------------

## CHAPTER VIII

## ACCESSORIES

Plug, sledge, single-handle and double-handle collector—Current reverser—Solid rheostats—Plug and graphite rheostats—Liquid rheostats—Rheophores—Electrodes—De Watteville's key—Care of a battery—The cut-out—The cut-out and commutator—Amalgamation of zincs—Localizing a fault	- - - - 92—108
---	----------------

## CHAPTER IX

## FARADIC ELECTRICITY

	PAGES
Inducing action of a magnet or of a current—Laws of induction—Faraday's law—Lenz's law—Extra current or counter E. M. F. of self-induction—Table of the methods of obtaining induced currents—The induction coil—Neef's hammer—The effects of alternating currents—Magneto-electric machines—The ordinary form—GaiFFE's—D'Arsonval's sinusoidal currents—Sinusoidal motors—Dynamo currents—Milne Murray's switch-board—The transformer—Various kinds of—Nodon valve—Chief physical differences between faradic and galvanic currents - - - - -	109—134

## CHAPTER X

## SECONDARY BATTERIES

Principles of Planté and Faure cells—Charging an accumulator from a battery and from the main—Care of an accumulator—Advantages and disadvantages of secondary cells—Choice of batteries—Fixed, portable, Voltolini's, and Reiniger's batteries - - - - -	135—147
---	---------

## PART II

*ELECTRO-PHYSIOLOGY*

## CHAPTER I

## PHYSIOLOGICAL EFFECTS OF ELECTRICITY

Division of subject into groups—Natural electrical phenomena—Non-polarizable electrodes—Dubois-Reymond's and D'Arsonval's electrodes—Cutaneous currents—Muscle and nerve currents—Continuous and intermittent currents—Hermann's view—Negative variation of Dubois - Reymond — Laws of Dubois-Reymond — Theories of Dubois-Reymond and D'Arsonval—Artificial muscle—Electrotonic currents—Effects produced by the external application of electricity—Static electricity 148—154	148—154
--	---------

## CHAPTER II

## GALVANIC ELECTRICITY

	PAGES
Electrotonus—Anelectrotonus—Katelectrotonus—Law of stimulation in the case of the human body—Polar and peripolar zones—Electrotonic explanation of the laws of contraction—Chauveau's results—The voluntary and involuntary muscles—The sensory nerves—The optic and auditory nerves—The brain—The elements in an electrical stimulus - - - - -	155—166

## CHAPTER III

## ELECTROLYSIS

Nature of an electrolyte—Anions—Kations—Faraday's laws—Theory of Grotthuss and Clausius—Secondary electrolysis—The body as an electrolyte—The blood, muscles, and urine—Interpolar action—M. Weiss's experiments—Cataphoresis—Trophic effects—M. D'Arsonval's experiments—Bactericidal action -	167—181
---	---------

## CHAPTER IV

## FARADISM

Physiological effects—Tetanus—Stimulation of nerves and muscles—Faradic anæsthesia—Trophic effect—Bactericidal action—Alternating sinusoidal currents—Use in stimulating unstripped muscle and in uterine affections	182—185
--	---------

## PART III

*ELECTRO-DIAGNOSIS*

## CHAPTER I

## ELECTRICAL RESISTANCE OF THE TISSUES AND CAPACITY OF THE HUMAN BODY

Difficulty of estimating—Standard electrodes—Table of resistances—Influence of age—Pathological alterations in the resistance—Hemianæsthesia—Graves' disease—Fevers—Metallic poisonings—Resistance of the individual tissues; of the urine in health and disease—Significance of the resistance—Effect of acute pneumonia and of diabetes mellitus—Resistance of artificial urines—Resistance of the urine in chronic Bright's
--

## CONTENTS

xiii

	PAGES
disease and in pernicious anæmia—Value in prognosis— Resistance of the blood ; how measured—Table of the resistance of the individual tissues—Electrical capacity of the body - - - - -	186—199

## CHAPTER II

### REACTIONS OF THE NERVES AND MUSCLES

Requisites—The motor points—Method of procedure in electro-diagnosis—(I.) Quantitative and (II.) qualitative changes—Faradic and galvanic superexcitability— Faradic and galvanic subexcitability—Conditions of occurrence - - - - -	200—211
--	---------

## CHAPTER III

### QUALITATIVE CHANGES

Serial and modal—Reaction of degeneration—Definition of R.D.—Etiology of R.D.—Presence in certain spinal and peripheral affections—Phenomena characteristic of R.D. —Quantitative and qualitative changes—Progress of R.D.—Pathology of R.D.—Varieties of R.D.—Value of R.D. in localization and prognosis—Alterations in the sensory nerves—Method of investigation—Changes in the reactions of the nerves of special sense—The optic, auditory, and gustatory nerves—Feigned diseases -	212—220
---	---------

## PART IV

### *ELECTRO-SURGERY*

## CHAPTER I

### SURGICAL USES OF ELECTRICITY

Methods of application—Requisites for electro-surgery— Removal of superfluous hairs—Trichiasis—Small tumours —Nævi—Varieties suitable for electrolysis—Requisites —Mode of operating—Goitres—Cirroid aneurisms— Aneurism by anastomosis—Aneurisms—Methods adopted—Unipolar—Bipolar—Risks of hæmorrhage or of inflammation—Dr. John Duncan's views—Indica- tions for electrolysis—Method of procedure—Dangers of the operation—Precautions—Results—Dr. John Duncan's experience of the value of electrolysis in aneurisms and the angiomata - - - - -	221—232
--	---------

## CHAPTER II

## STRICTURES

	PAGES
Advantages of electrolysis—Stricture of the urethra— Requisites—Mode of procedure—Results—Views of Dr. Steavenson, Mr. Bruce Clarke, Dr. Newman, etc.— Linear electrolysis—Urethritis—Hypertrophy of the prostate—Treatment of, by electrolysis, galvano-cautery, and galvano-puncture—Stricture of the rectum and of the Eustachian tube—Lachrymal obstruction—Stricture of the œsophagus - - - - -	233—242

## CHAPTER III

## DISEASES OF WOMEN

Fibroid tumours—Apostoli's claims—Polar and interpolar effects—Indications for the positive and negative poles, and for galvano-puncture—Results—Views of various authorities - - - - -	243—248
--	---------

## CHAPTER IV

## REQUISITES FOR THE APOSTOLI TREATMENT

Preparation of the apparatus and of the patient—The operation—Contra-indications—Galvano-puncture— Apostoli's rules—Risks of Apostoli's galvano-puncture —Endometritis—Dysmenorrhœa—Menorrhagia and Metrorrhagia—Malignant tumours—Extra-uterine foetation - - - - -	249—256
---	---------

## PART V

*ELECTRO-THERAPEUTICS*

## CHAPTER I

## PRINCIPLES OF ELECTRO-THERAPEUTICS

Stimulating, sedative, and trophic effects—Static electricity —Method adopted at the Salpêtrière Hospital—The static bath—Indications for the static bath—The electrical breeze—Indications for the electrical breeze— Electrical sparks and friction - - - - -	257—263
---	---------

## CHAPTER II

## GALVANIC ELECTRICITY

	PAGES
Its therapeutic uses—Density of the current—Modes of application—Unipolar, bipolar, stabile, and labile methods—Subaural galvanization—Central galvanization—General indications for galvanism—Direction of the current—Strength of current—Duration and repetition of séances—Self-application—Faradic electricity—Methods of application—Local faradization—General faradization—The faradic bath—Indications for the faradic bath—The galvanic bath—The electric douche—Galvano-faradization	- - - - 264—276

## CHAPTER III

## DISEASES

Principles of treatment—Spasms and contractures—Paralysis—Pain—Anæsthesia. <i>General neuroses</i> : Neurasthenia—Hysteria—Insomnia—Melancholia—Hypochondria—Chorea—Paralysis agitans—Exophthalmic goitre—Tetany—Writer's and telegrapher's cramp. <i>Affections of the brain and spinal cord</i> : Cerebral hæmorrhage—Infantile paralysis—Progressive muscular atrophy—Lateral sclerosis—Locomotor ataxy	- - - - 277—286
--	-----------------

## CHAPTER IV

## PERIPHERAL AFFECTIONS

Facial paralysis—Pressure and lead paralysis—Neuralgia: Tic douloureux—Sciatica—Tinnitus aurium. <i>Constitutional affections</i> : Acute and chronic rheumatism—Lumbago—Rheumatoid arthritis—Gout—Alkaline electrical baths—Diabetes	- - - - 287—294
---	-----------------

## CHAPTER V

## AFFECTIONS OF THE ALIMENTARY SYSTEM

Dyspepsia—Dilatation of the stomach—Gastralgia—Vomiting—Constipation—Obstruction—Prolapsus ani. <i>Diseases of the genito-urinary organs</i> : Enuresis nocturna—Paralysis and atony of the bladder—Spermatorrhœa and impotence—Amenorrhœa—Uterine and ovarian pain—Subinvolution—Galactagogue effects. <i>Diseases of the skin</i> : Eczema—Acne—Alopecia areata—Urticaria—Herpes—Pruritus—Elephantiasis arabum—Parasitic affections	- - - - 295—305
---	-----------------

## CHAPTER VI

## THE ELECTRIC CAUTERY AND LIGHT

	PAGES
The electric cautery—Lighting purposes—The laryngoscope —Cystoscope — The electro-magnet for ophthalmic work - - - - -	306—314

## PART VI

## RÖNTGEN X RAYS

## CHAPTER I

## RÖNTGEN X RAYS

Nature and mode of production of—Coil and interrupters. ' <i>Mercurial</i> ' : Dip—M. Davidson—Jet. ' <i>Electrolytic</i> ' : Wehnelt. ' <i>Rubbing contact</i> ' : Dawson Turner, Con- tremoulins-Gaiffe—Static machine—Advantages and dis- advantages of—Focus tubes—Regulation of vacuum	315—340
---	---------

## CHAPTER II

RÖNTGEN X RAYS—*continued*

Fluorescence—Localization of foreign bodies—Stereoscopic work—Screen appearances in clinical work ; phthisis, empyema, etc.—Benoist's radio-chromomètre—Table of relative transparency — Antiseptic dressings — Photo- graphy, technique — Extra-rapid plates — Renal calculi - - - - -	341—368
--	---------

## CHAPTER III

## FINSSEN LIGHT AND RADIUM RADIATIONS

Production and recognition of ultra-violet rays—Penetra- tive power of—Employment of—Finsen large lamp— Lortet-Genoud, Finsen-Theyn, Bang, Strebelt—Condenser spark—Compressing media : Rock-salt, ice, quartz— Becquerel's discovery of radio-activity—Radio-active elements—Properties of radium—Alpha, beta, gamma rays—Bactericidal and physiological action of radium —Blondlot's N rays - - - - -	369—386
--	---------

CHAPTER IV

RÖNTGEN RAY, FINSEN LIGHT, AND RADIUM THERAPEUTICS

	PAGES
Carcinoma : Cases, results—Sarcomata : Cases, results— Quinine as an adjuvant—Rodent ulcer—Lupus—Lupus erythematosus — Tubercular glands and joints— Eczema—Psoriasis—Sycosis—Favus—Mycosis fungoides —Sinus — Trachoma — Neuralgia — Comparison of Röntgen rays and Finsen light—X-ray dermatitis	387—403

CHAPTER V

HIGH-FREQUENCY CURRENTS

Mode of production of—Tesla coil—D'Arsonval's bipolar transformer—Oudin's resonator—Method of employment of — Auto-conduction — Auto-condensation — Effluve— Physiological and nutritional effects—Therapeutic appli- cations — Phthisis — Hæmorrhoids — Trachoma—Malignant disease, etc. - - - - -	404—419
--	---------

APPENDIX

USEFUL FORMULÆ - - - - -	420
ENGLISH AND METRIC MEASURES - - - - -	420
INDEX - - - - -	422





## LIST OF ILLUSTRATIONS

FIG.	PAGE
1. Scraps of paper attracted by glass rod - - -	4
2. Attraction and repulsion of pith-balls - - -	5
3. Electroscope - - - - -	7
4. Leyden jar - - - - -	9
5. Wimshurst machine - - - - -	12
6. Multiplate Wimshurst machine (Griffin) - - -	14
7. Horseshoe electro-magnet - - - - -	18
8. Magnetic axis and equator - - - - -	18
9. Magnetic lines of force - - - - -	19
10. Direction of lines of force - - - - -	19
11. Direction of lines of force - - - - -	19
12. Simple galvanic cell - - - - -	25
13. Diagram to represent continuous, interrupted and alternating currents - - - - -	32
14. Leclanché cell - - - - -	36
15. Leclanché-Barbier cell - - - - -	38
16. Insulated Leclanché - - - - -	39
17. Bottle bichromate - - - - -	41
18. Bichromate battery - - - - -	42
19. Gaiffe's persulphate of mercury battery - - -	43
20. Arrangement of zinc or carbon - - - - -	44
21. Obach dry cell (Siemens) - - - - -	45
21A. Helleisen cells - - - - -	46
22. Daniell cell - - - - -	49
23. Daniell cell of low resistance - - - - -	50
24. Gravity cell - - - - -	50
25. Bunsen cell - - - - -	52
26. Three cells in series - - - - -	55
27. Seven cells in series - - - - -	55
28. Opposing electro-motive forces - - - - -	57
29. Kohlrausch's bridge (Schall) - - - - -	65
30. Cells in parallel - - - - -	69
31. Cells in parallel - - - - -	70
32. Cells in multiple arc - - - - -	73
33. Cells in multiple arc - - - - -	74

FIG.	PAGE
34. Voltmeter - - - - -	79
35. Action of current on needle - - - - -	80
36. Diagram of current on needle - - - - -	82
37. Mirror galvanometer - - - - -	84
38. Diagram of a galvanometer - - - - -	85
39. Galvanoscope - - - - -	86
40. Divided circuit - - - - -	87
41. Galvanometer shunts - - - - -	87
42. Edelmann's galvanometer (Schall) - - - - -	88
43. D'Arsonval's galvanometer (Gaiffe) - - - - -	89
44. D'Arsonval's portable milliampère meter (Schall) - - - - -	90
45. Plug collector - - - - -	93
46. Single collector (Schall) - - - - -	94
47. Double collector (Schall) - - - - -	95
48. Double collector (Schall) - - - - -	95
49. Connections of double collector (Schall) - - - - -	96
50. Current reverser - - - - -	96
51. Connections of current reverser - - - - -	97
52. Plug rheostat - - - - -	98
53. Plug rheostat - - - - -	98
54. Sliding rheostat - - - - -	99
55. Simple liquid rheostat - - - - -	100
56. Liquid rheostat - - - - -	101
57. Make and break handle (Schall) - - - - -	103
58. Pillow electrode (Schall) - - - - -	104
59. Roller electrode (Schall) - - - - -	104
60. De Watteville's key (Schall) - - - - -	105
61. Plug switch - - - - -	105
62. Cut-out and commutator - - - - -	107
63. Action of magnet on closed circuit - - - - -	109
64. Action of current on closed circuit - - - - -	110
65. Current in opposite direction at closing - - - - -	111
66. Current in same direction at opening - - - - -	112
67. Mode of collecting primary current - - - - -	114
68. Induction coil - - - - -	116
69. Plan of induction coil - - - - -	117
70. Pendulum hammer - - - - -	118
71. Magneto-electric machine - - - - -	120
72. Curves of currents (D'Arsonval) - - - - -	121
73. Single phase sinusoidal motor - - - - -	122
74. Single or three phase sinusoidal motor (Schall) - - - - -	123
75. Motor transformer yielding alternating current for light and cautery (Schall) - - - - -	124
76. Interrupter transformer (Schall) - - - - -	125
77. Plan of portable switch-board - - - - -	126
78. Diagram of connections to main for cautery and large coils - - - - -	126

LIST OF ILLUSTRATIONS

xxi

FIG.	PAGE
79. Milne Murray switch-board - - -	128
80. Plan of arrangement of Milne Murray switch-board -	129
81. Alternating current simple transformer (Schall) -	131
82. Motor dynamo transformer (Schall) - - -	133
83. Accumulator in glass vessel - - -	137
84. Drake and Gorham's curve - - -	137
85. Charging a secondary cell - - -	138
86. Lamps in parallel for charging an accumulator -	139
87. Plan of connections - - - -	139
88. Hydrometer - - - -	141
89. Hydrometer - - - -	141
90. Combined portable battery - - -	143
91. Voltolini's battery - - -	144
92. Sledge coil with dry cells - - -	145
93. Induction coil with dry cell - - -	146
94. Reiniger's acid battery - - -	147
95. Polar and peripolar zones - - -	161
96. Anodal and kathodal areas - - -	162
97. Galvanic and electrolytic cells - - -	169
98. Electrolysis apparatus - - -	170
99. Theory of electrolysis - - -	171
100. U-tubes for electrolysis - - -	177
100A. U-tube for measuring resistance of liquids - -	191
101. Motor points of head and neck (Ziemssen) - -	202
102. Motor points of anterior surface of left arm (Ziemssen)	204
103. Motor points of posterior surface of left arm (Ziemssen) - - - - -	204
104. Motor points of forearm (Ziemssen) - - -	205
105. Motor points of forearm (Ziemssen) - - -	206
106. Motor points of posterior surface of thigh (Ziemssen) -	207
107. Motor points of anterior surface of thigh (Ziemssen) -	207
108. Motor points of outer surface of leg (Ziemssen) -	208
109. Motor points of inner surface of leg (Ziemssen) -	209
110. Motor points of anterior surface of trunk (Ziemssen) -	210
111. Curve of muscular closing contraction (Erb) - -	214
112. Reaction of degeneration (Erb) - - -	214
113. Reaction of degeneration (Erb) - - -	214
114. Scheme of degeneration (Erb) - - -	215
115. Scheme of degeneration (Erb) - - -	216
116. Scheme of degeneration (Erb) - - -	216
117. Scheme of partial form of R.D. - - -	217
118. Electrolysis needle - - -	222
119. Epilation needle handle (Coxeter) - - -	223
120. Lewis Jones' and other needles (Schall) - - -	225
121. Urethral electrodes - - -	234
122. Eustachian catheter - - -	240
123. Uterine sound electrode - - -	250

FIG.	PAGE
124. Milne Murray's electrodes - - -	250
125. Apostoli's electrodes - - -	251
126. Arrangements of Apostoli's apparatus - -	252
127. Static electrodes - - -	259
128. Insulating stool - - -	259
129. Galvanic current diffusion (Erb) - - -	264
130. Galvanic current diffusion (Erb) - - -	265
131. Rectal electrode - - -	297
132. Schech's cautery handle - - -	306
133. Electrical laryngoscope - - -	308
134. Hurry Fenwick's cystoscope - - -	308
135. Cystoscopic phantom - - -	311
136. Ophthalmic electro-magnet - - -	312
137. Similar magnet wound for electric light current (Schall) - - -	313
138. Haab's electro-magnet wound for electric light current (Schall) - - -	313
139. Induction coil (Apps) - - -	319
140. Dipping interrupter (Schall) - - -	321
141. Mackenzie Davidson interrupter (Schall) - -	322
142. Mercury jet interrupter (Schall) - - -	323
143. Mercury jet interrupter, later form (Schall) - -	323
144. Wehnelt interrupter (Schall) - - -	324
145. Wehnelt interrupter, new pattern (Schall) - -	325
146. Wehnelt discharge - - -	326
147. Dawson Turner interrupter - - -	327
148. Contremoulins-Gaiffe interrupter (Gaiffe) - -	329
149. Adjustable resistance - - -	330
150. Resistance for working coils from the main (Schall) -	331
151. Alternate current rectifier (Schall) - - -	332
152. Focus tube - - -	333
153. Penetrator tube (Watson) - - -	334
154. Hirschmann's tube with regulating arrangement -	336
155. Tube-holder (Schall) - - -	337
156. Valve tube (Schall) - - -	337
157. Coil with adjustable self-induction (Schall) - -	338
158. Spirit lamp on insulating handle (Schall) - -	339
159. X-ray tube properly excited (Miller) - - -	339
160. Dawson Turner tube with adjustable kathode (Griffin)	339
160A. Therapeutic tube (Cossor) - - -	340
161. Leathern purse containing coins and a key (photographed January, 1896, with a Crookes' tube) -	343
162. Rabbit's paw - - -	343
163. Hand showing needle - - -	345
164. Dislocation of terminal phalanx of thumb - - -	345
165. Injected bloodvessels of kidney - - -	346
166. Injected bloodvessels of heart - - -	347
167. Dunfermline shooting case - - -	349

LIST OF ILLUSTRATIONS

xxiii

FIG.	PAGE
168. Broken radius and old injury to wrist (photographed through splints) - - - -	349
169. Localization diagram - - - -	350
170. Elbow of boy of fifteen with ununited epiphysis -	351
171. Precious stones and their imitations - -	351
171A. Localization couch - - - -	352
172. Adult foot - - - -	353
173. Foot in shooting-boot - - - -	353
174. Opaque envelopers - - - -	354
175. Chinese foot - - - -	355
176. Seven-toed foot - - - -	355
177. Normal ankle-joint - - - -	357
178. Semiflexed knee - - - -	357
179. Extended knee, showing shot - - - -	359
180. Neck, etc. - - - -	359
181. Halfpenny in thorax - - - -	361
182. Trunk and upper extremities (Wilson Noble) -	363
183. Finsen arc light - - - -	375
184. Finsen-Reyn lamp (Schall) - - - -	377
185. Dr. Bang's lamp, dermo pattern (Sanitas Company) -	378
186. Installation of dermo lamp (Sanitas Company) -	378
187. Dr. Strebel's lamp (Schall) - - - -	379
188. Condenser spark lamp (L. Miller) - - - -	380
188A. Dr. Macleod's radium applicator (Martindale) -	387
189. Leyden jars charged by coil (Schall) - - - -	405
190. Closed iron circuit transformer (Schall) - - - -	406
191. Switchboard for transformer (Schall) - - - -	407
192. Rectifier for Röntgen-ray work (Schall) - - - -	408
193. Diagram of Tesla oil induction coil - - - -	409
194. D'Arsonval's bipolar transformer (Schall) - - - -	410
195. Oudin's resonator and solenoid (Schall) - - - -	411
196. High-frequency electrodes (Schall) - - - -	412
197. High-frequency electrodes - - - -	412
198. Glass electrodes for rectum, vagina, etc. (Schall) -	413
199. Auto-conduction (Schall) - - - -	414
200. High-frequency milliampère meter (Gaiffe) - - - -	415



# A Manual of Practical Medical Electricity

## INTRODUCTION

THOUGH electricity varies in its character and effects according to the method we adopt to develop it, and though we may contrast it in its negative and positive phases, yet it is important to recognise at the outset that there is essentially only one kind of electricity.

If we develop it by friction between non-conductors, we obtain it in its static form ; if by contact between conductors in the presence of chemical action or of heat, in its galvanic form ; and if by induction by magnets, or by currents, in its faradic form.

Yet, however obtained, the difference in its character is only one of degree.

It is usual in medical practice to speak of these three forms : static, galvanic, faradic.

Static or frictional electricity is the form which the ancient philosophers used to obtain by rubbing certain substances together, the one of which became positively, and the other negatively, electrified.

The characteristics of electricity thus liberated are that it is in a condition of great strain, but that it is very little in quantity ; it is of very high electro-motive force, *i.e.*, the potential difference between its terminals is great, but, in consequence of its great internal resistance, its capacity for sending a continuous current along a conductor is very



## 2 A MANUAL OF PRACTICAL MEDICAL ELECTRICITY

small ; it is electricity in a state of strain on non-conductors as opposed to electricity in motion along conductors.

In 1780 Galvani discovered what was thought to be a new form of electricity, and Volta, in 1800, a means of developing it almost continuously—a form now termed galvanic, voltaic, chemical, contact, or current electricity.

It differs widely in degree from the frictional form ; it is not in a condition of great strain—that is, its electromotive force is usually low—but its current capacity is large, because the internal resistance is low.

Lastly, in 1831, Faraday succeeded in generating currents of electricity by means of magnets and of conductors already carrying currents, and this is termed faradic, magneto, or induced electricity. It occupies, as regards its properties, a more or less intermediate position.

It was usual formerly to lay some stress upon the differences of these forms of electricity, and I have accordingly mentioned some of them ; but it must not therefore be thought that they are not interchangeable.

For example, it would be quite possible to set up a galvanic battery large enough to exhibit all the phenomena of frictional electricity ; and there is, in fact, quite as great a difference of potential between the terminals of one of the London electric supply dynamos as there is between the positive and negative conductors of a frictional machine when they are about  $\frac{1}{8}$  inch apart. Further, a stronger current can be given by a frictional machine, as evidenced by a galvanometer, than by a galvanic cell working through a high resistance.

We now proceed to consider these forms in greater detail.

PART I  
*ELECTRO-PHYSICS*

CHAPTER I  
**STATIC OR FRICTIONAL ELECTRICITY**

WE have from all ages been accustomed to certain atmospheric phenomena, such as discharges of lightning or the appearance of the Aurora Borealis. These were termed manifestations of common or atmospheric electricity, and are now included under the general term Static or Frictional electricity (see Introduction).

Before the discoveries of Galvani this was the only form used therapeutically ; displaced in turn by galvanic and faradic currents, it is now finding renewed favour, and no infirmity electrical department can be considered complete without a well-equipped static room. Previous work with static electricity was done by, amongst others, Dr. Golding Bird, Addison, and Sir W. Gull (Guy's Hospital Reports, 1837, and later) ; but the more recent advances have been associated with the names of Frenchmen, such as Vigouroux, and Americans, as Monell. Dr. Steavenson, of Bartholomew's, suggested that slight attacks of malaise, and even graver alterations of the health, might be due to changes in the atmospheric electricity, and in this connection he pointed out that conditions of weather, which are commonly supposed to be more or less inimical to our well-being, such as bad weather, thunderstorms, etc., are

accompanied by a diminution in the positive and an increase in the negative atmospheric charge. In one instance, when he had by accident charged himself negatively, there followed a severe asthmatic attack, which he ascribed to the electricity. Lord Kelvin has shown that the breaking and splashing of waves on the seashore is a powerful source of atmospheric electricity, and that sea-air is strongly electrified. Are we to look in this direction for part of the bracing effect produced by a residence at the seaside? Further, the atmospheric electrical potential increases within certain limits as we ascend from the sea-level, so that at high altitudes it may be considerable. Thus part of the good effect of mountain air may be traced to this cause.

### Simple Static Phenomena.

When we rub a piece of glass with a silk handkerchief, or a piece of sealing-wax with flannel, we find that they have acquired the property of attracting all other bodies, a phenomenon most easily shown by such light substances as scraps of paper or pith-balls. This property is exhibited by both the rubbed body and the rubber, and the

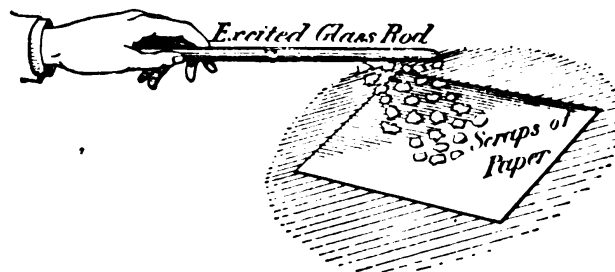

FIG. 1.—GLASS ROD AND SCRAPS OF PAPER.

agency to which they owe this property is termed electricity. Yet though they be equally, they are not similarly electrified. Rub a glass tube with a piece of silk, and then bring it near to a pith-ball suspended by a thread. The ball will be attracted; let the glass rod touch the ball, and it will be repelled. If, however, we now bring the piece

of silk near the ball (taking care to handle it as little as possible) it will be attracted to it.

The electricity developed upon the piece of glass is termed positive (+), the electricity developed upon the piece of silk is termed negative (-); meaning thereby not that two different kinds of electricity have been developed, but two different amounts, the body charged positively having more, and the body charged negatively having less, than the normal amount.

The ball is attracted by the positive electricity of the glass until it is by contact itself charged with it, when it

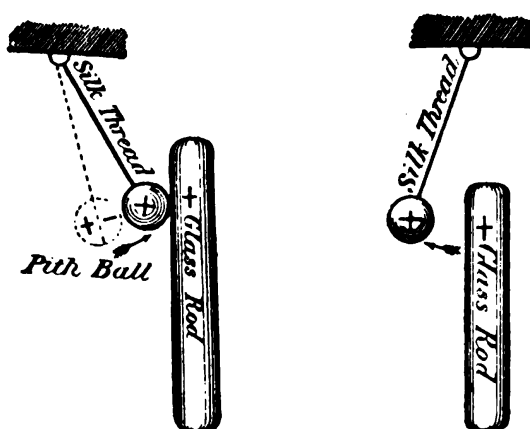

FIG. 2.—PITH-BALL ATTRACTED AND REPELLED BY GLASS ROD.

is repelled (Fig. 2); we can, therefore, say that positively charged bodies repel each other (like electricities repel); and as the positively charged ball is attracted by the negatively charged silk, we see further that positively charged bodies attract negatively charged ones (unlike electricities attract).

If we charge a pith-ball positively by the glass, and then hold it towards a piece of sealing-wax rubbed with flannel, we shall see that the ball is attracted; the sealing-wax must therefore be charged negatively. Bring a fresh pith-ball near the sealing-wax, it will be attracted; let it touch it, and it will be repelled; hold the glass rod near to it, and it will be attracted; negatively charged bodies there-

## 6 A MANUAL OF PRACTICAL MEDICAL ELECTRICITY

fore also repel each other, according to the law already mentioned, that like electricities repel.

It must not be supposed that glass and sealing-wax, and other non-conductors, are the only bodies which exhibit these phenomena, for if proper precautions be taken, all bodies, speaking generally, may be made to do so. The earth and everything upon it may be taken to be electrified to a certain degree (potential), though as long as this is equally shared by them, as long as there is between neighbouring bodies no difference of potential, the electricity is non-evident.

By rubbing any two bodies together, *i.e.*, by bringing them into good contact, we produce a difference of potential; that is to say, we disturb the existing equilibrium, the electricity of higher potential collecting upon the positively electrified body, and the electricity of lower potential upon the negatively electrified body. The degree to which the earth is electrified being taken as the standard, a body that is positively electrified is assumed to be electrified to a higher degree, and a body that is negatively electrified to a lower degree, than that of the earth. The amount so obtained is, however, so small in quantity that in good conductors, such as the metals, along which it can easily pass, it is inappreciable; while in non-conductors, glass, etc., along which it is not able to immediately diffuse itself, it can be examined and studied.

We have seen that we can charge a body with electricity by touching it with one already charged, *i.e.*, by *conduction*. We can, however, also produce this condition by *induction* without letting the bodies touch each other. When we hold an excited glass rod near a light ball, the latter is, as we have seen, attracted. Why is this so? Because the positive charge on the glass rod 'induces' through the intervening air and without actual contact a negative charge upon the side of the ball nearest to the rod, while an equal charge of positive will pass to the other side of the ball (Fig. 2).

As unlike electricities attract, the positively charged

glass rod attracts the nearer half of the ball, which is charged negatively.

### The Electroscope.

To observe this and some of the other phenomena of statical electricity the better, we can use an electroscope. This instrument enables us to detect the presence of charges of electricity, and their nature—whether positive or negative. Briefly, it consists of a glass jar containing two pieces of gold-leaf suspended by a piece of wire, which passes upwards through the cork in the mouth of the jar to terminate in a brass plate.

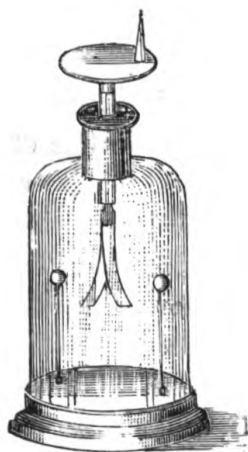

FIG. 3.—ELECTROSCOPE.

If we hold the electrified glass rod near the plate, negative electricity accumulates by induction at the plate, and positive electricity passes down to the gold-leaves; the latter, therefore, being repelled from each other by a like charge, diverge. Should we remove the glass rod, the leaves will collapse, and the charges induced in the electroscope will disappear; but the glass rod will have lost none of its electrification. If we repeat the experiment, and touch the plate with the finger while the electroscope is under the influence of the glass rod, then the *positive* electricity of the divergent leaves will escape to earth along the finger; the negative will be unable to escape because

## 8 A MANUAL OF PRACTICAL MEDICAL ELECTRICITY

it is under the attraction of the positively electrified glass rod. But if we now withdraw the glass rod a free charge of negative will remain, and cause the leaves to diverge permanently with negative electricity. In this way an electroscope can be given a permanent charge. If the experiment be repeated, using a piece of ebonite rubbed with catskin (negative electrification), then the leaves can be given a permanent positive charge. To prove the nature of this charge we can bring up the rubbed glass rod, which, according to the law that like electricities repel, will force more positive electricity down to the leaves, and therefore cause them to diverge still further. To ascertain whether a body be charged, we bring it up to an uncharged electroscope, when, if the leaves diverge ever so little, the body must be charged.

To determine further whether it be charged positively or negatively, we first charge the electroscope positively by means of the electrified ebonite rod, and then hold the body, whose charge is to be determined, towards the plate: if the charge be a positive one, the leaves will tend to diverge even more; if, however, the charge be a negative one, they will tend to collapse, because the positive electricity, which was repelling them from each other, is now attracted to the plate.

### The Leyden Jar.

A Leyden jar or condenser consists of two conducting surfaces close to, but separated from, each other by a non-conductor or dielectric. A simple one can be made by suspending two metal plates by silk threads opposite one another, with only a thin stratum of air between them.

Having attached one plate to earth (to a gas-pipe) by a wire, charge the other positively by connecting it with the conductor of an electrical machine; the positive electricity on the charged plate will induce a negative charge on the other plate, and as these are mutually attractive, they pass into what is termed a bound condition on the near sides of

the conductors. This permits of our increasing the positive charge on plate one, which in turn induces more negative electricity on plate two, to be reacted on as before.

This process of storing up or accumulating electricity can be continued until the pressure becomes so great—if we have a machine powerful enough—that the positive and negative charges reunite by means of a spark passing through the intervening air.

A Leyden jar is a convenient condenser, made by lining the inside and outside of a glass jar to about three-quarters of its height with tinfoil or gold-leaf. Through the cork is passed a conductor of brass, which makes connection on



FIG. 4.—LEYDEN JAR.

the inside with the tinfoil by means of a piece of brass chain, and which terminates on the outside in a knob (Fig. 4).

The two coatings of tinfoil form the conducting surfaces, which are separated from one another by the non-conductor or dielectric glass. If the knob be brought into contact with the positive conductor of a working electrical machine while the outer coating is either held in the hand or connected to earth by a wire, the inner coating will become positively, and the outer coating negatively, charged.

To discharge such a jar through the body, hold the outer



## 10 A MANUAL OF PRACTICAL MEDICAL ELECTRICITY

coating in one hand and touch the knob with the other ; the two electricities will now unite through the body as the conductor, with the communication of a severe shock. This effect can be much increased by coupling several jars together. A condenser will hold a much larger quantity of electricity than a simple conductor ; its capacity is greater.

The function of a Leyden jar is to act as a reservoir or storehouse of electricity, its capacity for containing electricity being very great. When it is desired to pass a large charge through a patient, we first accumulate the electricity in a Leyden jar, and then discharge it all at once through the patient. By this means muscles which are refractory to other forms of electrical stimulation may sometimes be made to contract. The capacity of a jar varies directly as the square of its radius, and is inverse to the thickness of the dielectric which separates the sheets of tinfoil. If, therefore, the radius of a jar be doubled, the thickness of the glass remaining the same, the capacity will be increased fourfold. Hence the danger of large jars.

### Conductors.

Those bodies along which electricity easily diffuses itself are said to be good conductors ; they offer but a slight resistance to its action upon them, or, in more popular language, to its flow. Of these silver and copper are the best.

Those bodies, on the other hand, along which it can scarcely pass, and which offer a great resistance to its action on them, are termed bad conductors or non-conductors. Between the two there is no sharp line of separation ; there are all grades of conductors, poor conductors and non-conductors, and each class runs insensibly into the other. The following is a short table of relative conductivity ; but it should be remembered that that which might be termed a non-conductor of electricity of low potential (galvanic) might be a fair conductor of electricity

of high potential (frictional). Further, moisture affects conduction. Dry air is an insulator, but moist air, by depositing a layer of water on surrounding objects, destroys their insulating properties.

TABLE OF RELATIVE CONDUCTIVITY.

<i>Good Conductors.</i>	<i>Poor Conductors.</i>	<i>Insulators.</i>
Silver.	Acid solutions.	The skin.
Copper.	Salt solutions.	Silk.
Zinc.	The body, excluding	Sealing-wax.
Platinum.	the skin.	Vulcanite.
Iron.	Ordinary water.	Paraffin.
Mercury.		Ebonite.
Carbon.		Glass.
		Dry air.

### Electrical Machines.

The old-fashioned frictional machine has been quite replaced by the 'induction' or 'influence' machine, of which there are several varieties: the Holtz, Voss, Gläser, Carré, and Wimshurst. The latter has now quite superseded the others in medical practice. Of the Wimshurst there are two chief varieties, according to whether the plates are provided or unprovided with sectors. The machine consists essentially of two plates of an insulating material mounted on a common axle, and capable of being rotated in opposite directions by means of leather bands, one of which is crossed. The plates may be made of glass, ebonite, or mica, and may be from 12 to 36 inches in diameter. Neutralizing rods or diametrical conductors are fitted to each plate; they should enclose an angle of about 60° with each other, and they need not be insulated; they serve the purpose of putting into momentary metallic contact the two portions of the plate at the opposite ends of any one diameter; they consist of brass rods terminating in fine wire brushes. Collecting combs arranged on a horizontal diameter, and consisting of two pairs of sharp points or knife edges turned inwards towards the plates, are also required. The combs are

connected respectively to the two prime conductors, and are carefully insulated by being supported on glass pillars.

Nothing more is required for a sectorless machine, but it is more usual to provide the rotating plates with sectors of metallic foil which are cemented on radially, at equal distances apart, to the outside of each plate (Fig. 5). The fewer the sectors the greater the length of spark, but the sparks recur less frequently. Small Leyden jars are in both types attached by their inner coatings to the prime conductors, and a means should be always afforded of dis-

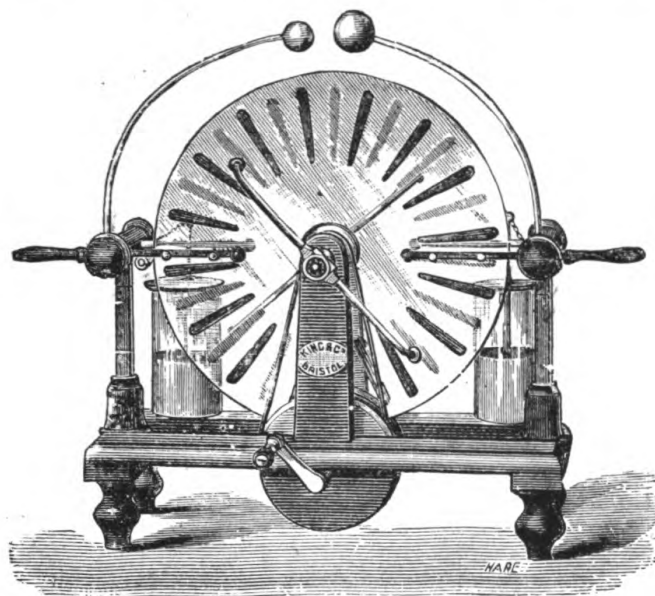

FIG. 5.—WIMSHURST MACHINE.

persing with the jars either by disconnecting the inner coatings from the machine or their outer coatings from one another. In the method introduced by Dr. Morton, and termed by him 'static induction,' the patient is placed by wires and electrodes between the outer coatings of the jars, while the prime conductors of the machine are brought together and then very slowly separated until they are about  $\frac{1}{4}$  inch, or less, apart. Every time a spark passes between the prime conductors, the patient will receive a shock, the severity of which will depend upon

the distance the prime conductors are apart and upon the size of the jars. Such discharges are oscillatory and extremely sudden, and have been made use of by Oliver Lodge to illustrate his theory of lightning conductors. Dr. Morton claims that they are less painful than shocks otherwise obtained, and that they will produce muscular contractions when other electrical methods fail. The effect of introducing the Leyden jars in the ordinary way into the circuit of the prime conductors is to diminish the number of sparks, and to increase their thickness and brightness and physiological effect. They do not raise the potential.

Holtz and Bonetti were the first to introduce the sectorless machine, and Gaiffe has so improved the type by supporting the plates of ebonite on heavy metal pillars, from which they are readily detachable, as to make large multiplate machines of this kind mechanically practicable. The disadvantage of the sectorless machine is that it is not self-exciting, and that it is very apt to become completely discharged and to require re-exciting ; otherwise the insulation is better, and the output, other things being equal, superior in the proportion of four to three. It will suffice as a rule to excite the machine to hold a rod of ebonite which has been rubbed with catskin close to one of the revolving plates : the collecting comb to which the plate is travelling will now become the negative pole ; or a dry finger, or one which has been lightly smeared with electric amalgam (bisulphide of tin) may be gently pressed against the revolving plate. When the plates have sectors the machine is self-exciting. Whether to choose ebonite, mica, or glass plates is a moot point.

Ebonite plates can be revolved about three times as rapidly as glass plates, with a correspondingly greater output, but they are apt to warp and to lose in sunlight their surface insulation. Glass plates do not suffer from these disadvantages, but they are liable to crack, and cannot be revolved so quickly. A two-plate machine is of but little use in medicine ; six plates are better, but for

Röntgen ray work ten or more plates are necessary. The plates should be from 18 to 30 inches in diameter (Fig. 6).

For those who use static electricity much, a motor of some sort to turn the machine is a necessity ; if connected to the electric light mains, an electro-motor is by far the

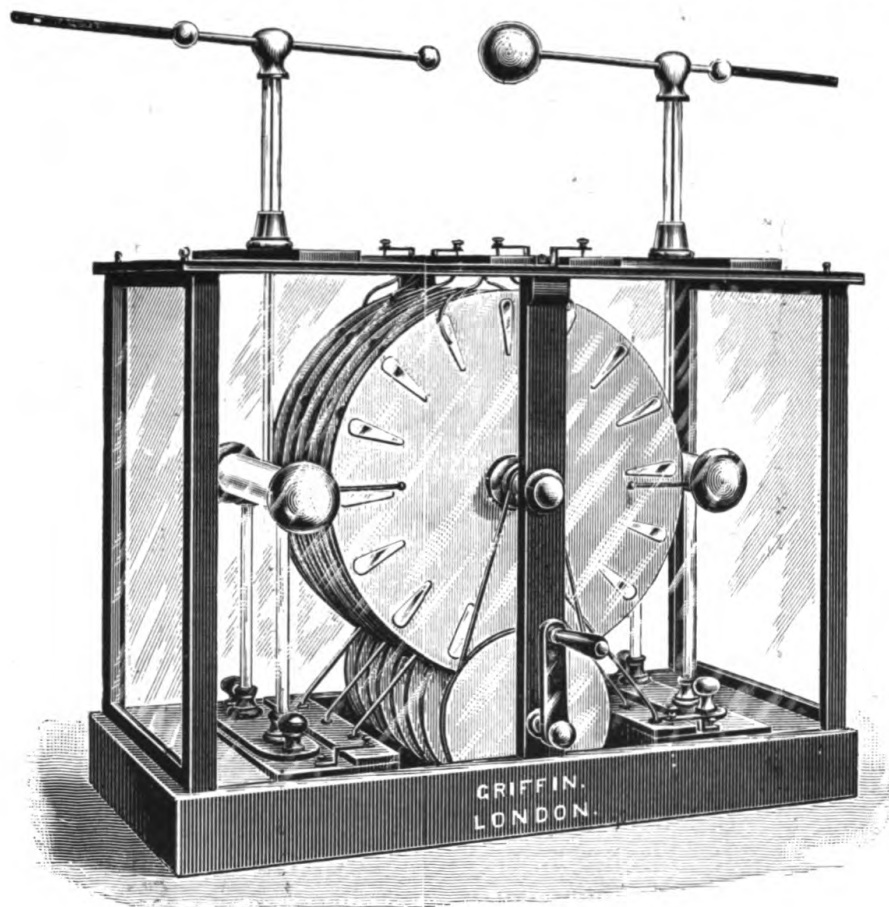

FIG. 6.—MULTIPLATE INFLUENCE MACHINE.

best ; it should be of about  $\frac{1}{6}$  horse-power. The Crypto Company, of Clerkenwell Road, supply such motors.

Whether it is better to enclose the machine in a case is also a question. A case protects the plates from dust, and permits the air to be dried by fused chloride of calcium or heated by electric lamps ; but electricity undoubtedly escapes to the walls of the case, and the ozoni

zation and nitrification of the air inside the case so produced militates against the efficient working of the machine. The author, on the whole, prefers to keep his machine unenclosed.

To make use of this form of electricity therapeutically we require, in addition to an electrical machine, an insulating stool or couch (one with long glass or ebonite feet), chains, wires, various electrodes, and an electro-scope.

The movable apparatus should, if possible, be carefully warmed before a fire, and any moisture wiped off. Particular attention should be paid to the glass insulators ; the air in the room should also be kept as dry as possible by a fire, for, in spite of these precautions, it is sometimes difficult in foggy weather to get the machine to work satisfactorily.

The usual method of application is to place the patient upon the insulating stool, and to connect him with the positive pole of the induction machine by means of a chain, thick wire, or tube. This may either rest upon the wooden top of the insulating stool or in the patient's hand. If the machine be now set in motion, the patient will become charged with positive electricity. The polarity of the terminals may be ascertained in the following way : Disconnect the Leyden jars and approach the conductors together until they are about 1 inch apart ; if the plates be now gently rotated, a violet spark will pass continuously between the poles, but that part which springs from the positive pole will be brilliantly white and about  $\frac{1}{4}$  inch in length. This may be further ascertained by testing the patient with the electro-scope, placed at a little distance. Should the patient extend his hand towards it, the leaves will diverge ; a rubbed glass rod will now either increase or decrease this divergence ; if the former, the patient is positively charged, and *vice versa*. The polarity may also be tested by placing a lighted candle between the poles ; the flame will be blown away from the positive pole, but drawn towards the negative. A pointed con-

## 16 A MANUAL OF PRACTICAL MEDICAL ELECTRICITY

ductor brought slowly up to the positive pole will exhibit a very small star of light, but if brought up to the negative a small brush discharge will be seen even at a distance of an inch away. The negative pole of the machine should be connected to earth by a wire attached to a gas or water pipe.

The further procedure depends upon the disease from which the patient may be suffering, and will be considered in the latter part of this book (see pp. 152 and 258).

## CHAPTER II

### MAGNETISM

WE term those substances magnets that have the power of attracting iron, nickel, and cobalt. These are the Ferromagnetics. There are both natural and artificial magnets. The natural magnets are composed of the magnetic oxide of iron, which is found in Magnesite in Asia Minor, in Sweden, and other places. This mineral has long been known as the lode (leading) stone. Artificial magnets are pieces of iron or steel which have been made magnetic.

Artificial magnets may be permanently or temporarily magnetized. A permanent magnet will retain its magnetism for an indefinite period, a temporary one only for so long a time as it is under the influence of a magnetizing force. We may suppose that all the particles of magnetizable bodies are small magnets, but arranged in every conceivable direction, so as to neutralize one another; under the influence of a magnetizing force the particles become arranged in regular order, and the body exhibits free magnetism. The retention of this power depends upon what is termed the coercive force of the material; the particles of bodies that have little coercive force are easily arranged in rows, but are as easily disarranged again—*i.e.*, they are readily magnetized and demagnetized (soft iron). The particles of bodies that have much coercive force are with difficulty magnetized, but retain whatever magnetism is given them (steel). Artificial magnets may be made in various ways; soft iron becomes magnetic when touched by a magnet, or when an electrical current is passed round



it ; this forms the ordinary electro-magnet. A horseshoe-shaped bar of soft iron is encircled by a coil of insulated

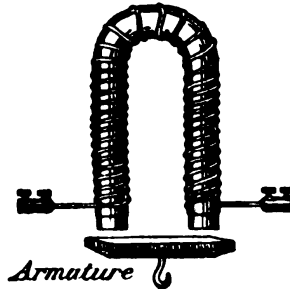

FIG. 7.—HORSESHOE ELECTRO-MAGNET.

copper wire, the iron becoming magnetic during the passage of a current along the wire (Fig. 7). (See Part V., Chapter VI.)

### Poles of a Magnet.

If a bar magnet be plunged into iron filings, these will be found to adhere mainly to the two ends ; these points where the attraction seems to be strongest are called the

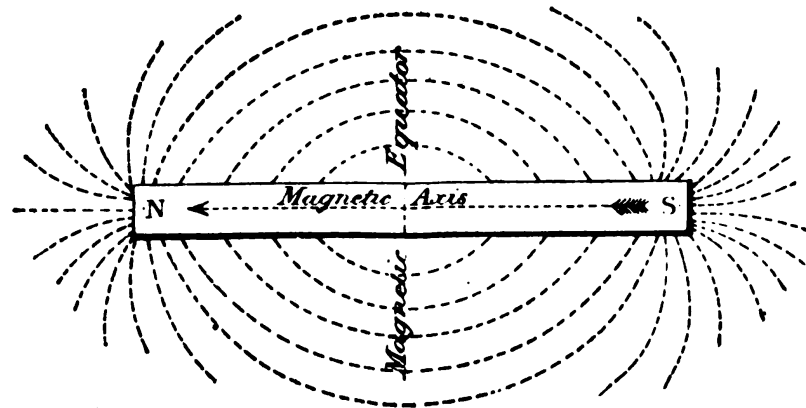

FIG. 8.—DIAGRAM OF A BAR MAGNET.

*poles*. An imaginary line joining the two poles is termed the magnetic axis, and a line drawn at right angles to and bisecting this is termed the magnetic equator (Fig. 8).

### Lines of Force.

The space round a magnet is regarded as being full of magnetic lines of force proceeding from one pole to the

other ; these complete their circuit in the substance of the magnet (Fig. 9). The space occupied by the lines of force outside the magnet is the magnetic field, or external

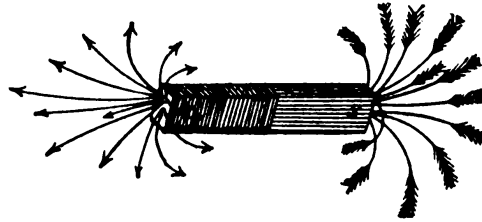
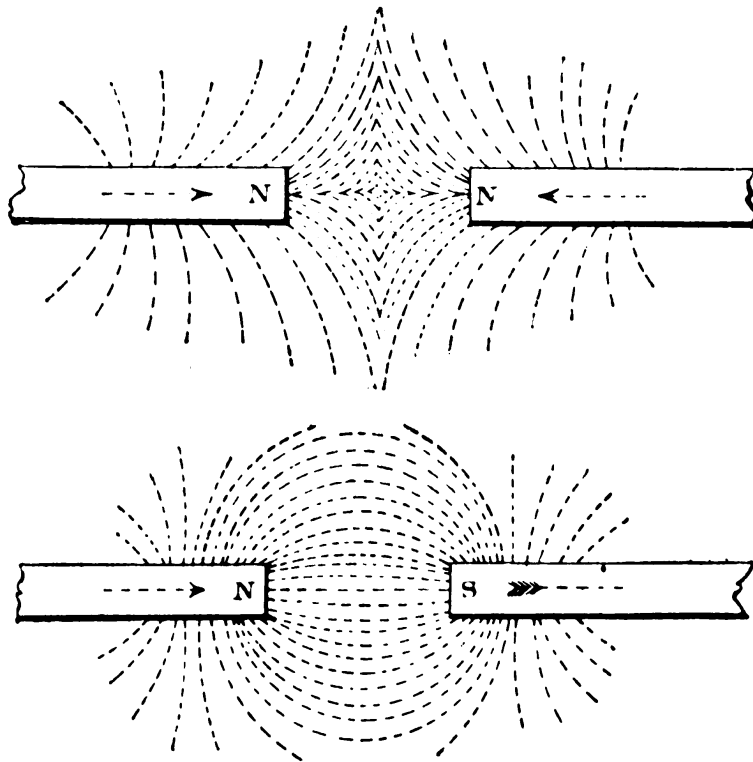

FIG. 9.—DIRECTION OF LINES OF FORCE.

magnetic field. The direction of the lines of force can be made visible by a simple and instructive experiment. Lay two bar magnets on a table, first with their like poles



FIGS. 10 AND 11.—DIRECTIONS ASSUMED BY IRON FILINGS.

opposite, and then with their unlike poles opposite each other ; cover them with a piece of cardboard or paper, and then sprinkle iron filings over them, while gently

tapping the paper ; the filings will now arrange themselves in definite curved lines (Figs. 10 and 11).

### Properties of a Magnet.

1. A magnet will strongly attract certain materials, such as iron, nickel, and cobalt. These are called the ferro-magnetics.

2. A magnet exercises a feeble attraction on certain other bodies, such as oxygen, chromium, and manganese. These are termed the paramagnetics.

3. All other bodies are very feebly repelled by a strong magnet. These bodies are called diamagnetics, and of them bismuth is the best example. Their repulsion by a magnet is probably due to their possessing less magnetic susceptibility than the surrounding medium.

4. If a bar magnet be capable of free movement, as when suspended by a thread, one pole will point to the north and the other to the south. The pole that points to the north is called the north pole, or north seeking pole ; the pole that points to the south is called the south pole. (The terms plus and minus are sometimes used to designate the poles.)

5. The unlike poles of magnets attract each other, the like poles repel ; thus a north pole will attract a south pole, but repel a north pole (Figs. 10 and 11).

6. A magnet tends to place itself parallel to a line of force. It is for this reason that the lines of force can be made visible by iron filings ; the latter, becoming magnetic under the influence of the magnet (magnetic induction), at once attempt to place themselves parallel to the lines of force of the magnet. There are lines of force round a wire along which an electrical current is flowing, and if a magnetic needle be brought near, it will attempt to place itself parallel to these. The magnetic needle points north and south because it thus lies along the lines of force which curve round the earth from one pole to the other, the earth behaving as a large magnet.

The phenomena of magnetism somewhat resemble those

of statical electricity ; thus, an electrified body attracts another body, and oppositely electrified bodies attract, while similarly electrified bodies repel ; but a magnet only attracts a very few bodies, and magnetism cannot be passed on like electricity ; *i.e.*, after touching a body with a magnet there is no subsequent repulsion. An electrified glass rod will attract a pith-ball until it touches it, when there will be repulsion, but iron filings which are allowed to touch a magnet are not subsequently repelled ; there is *no conduction* of magnetism.

It is a curious fact that so far as it is at present known no physiological or pathological effect is produced by even the most powerful magnets.

## CHAPTER III

### GALVANIC ELECTRICITY

WE obtain by galvanic electricity a continuous current, whose electro-motive force and current-strength can be graduated as we may desire, and which may be made to yield stimulant and restorative, or soothing and sedative, effects, according to our method of application.

Galvanic electricity is best obtained from a collection of cells, termed a battery, or from a continuous current-dynamo.

A primary cell consists of a vessel containing two conductors and an exciting substance, or electrolyte (p. 167).

The conductors must be dissimilar as regards their reaction with the electrolyte—*i.e.*, the latter must have more action upon one than upon the other.

This action is a chemical one ; and it consists primarily in an oxidation of one of the conductors at the expense of the liquid.

One of the conductors must therefore be more readily oxidizable than the other.

An electrical current cannot be obtained from a galvanic cell without a corresponding chemical action.

We therefore choose for our two conductors or plates substances as widely removed as may be convenient as regards their relative liability to oxidation ; one plate is therefore usually made of zinc, which is readily oxidizable, while the other may be made of copper, silver, platinum, or carbon.

There is, however, in choosing our plates, another and more important consideration, known as Volta's contact law.

### Volta's Contact Law.

Volta found that when two dissimilar metals were brought into contact, the one became positively and the other negatively electrified—that is, that a difference of potential was manifested. He found also that this difference varied with the nature of the metals.

Thus, if zinc be brought into contact with iron, the zinc becomes positively and the iron negatively electrified, and both to a certain degree (potential). If, however, zinc be brought into contact with copper, the zinc becomes more positively electrified than it was before, and the copper more negatively electrified than the iron—that is to say, a greater potential difference is manifested by the contact of zinc and copper than by the contact of zinc and iron.

Further, if iron be brought into contact with copper, the iron becomes positively and the copper negatively electrified; but if copper be brought into contact with platinum, the copper becomes positively and the platinum negatively electrified.

The metals can accordingly be arranged in such a series that each on the list will become positively electrified when brought into contact with any metal succeeding it; and negatively, with any metal preceding it.

Contact series of metals in air :

+ Sodium.	Iron.
Magnesium.	Copper.
Zinc.	Silver.
Lead.	Gold.
Tin.	Platinum.
	—Carbon.

Moreover, the further a metal is removed in the series from another, the greater will be the degree to which each will become electrified—that is, the greater will be the

potential difference and electro-motive force generated by bringing them into contact.

Thus, between zinc and tin the difference of potential in volts (see p. 28) developed by bringing them into contact is about '279, while between zinc and carbon it is about 1'09.

Volta laid down the following law : ' The difference of potential between any two metals is equal to the sum of the differences of potentials between the intervening metals in the contact series.'

Further, the difference of potential established by bringing any two dissimilar bodies into contact in air depends only upon their nature, and is unaffected by their form and dimensions.

We therefore, in constructing a cell, endeavour, other things being equal, to choose as our conductors metals that stand far apart in Volta's contact series, so as to obtain as high a degree of electrification (potential difference or electro-motive force) as we can ; for, according to his law, the further from each other they are in the series, the greater will be the electro-motive force of the combination.

Now, it will be found that those metals which are placed at the electro-positive end of the contact series are also those which are most oxidizable, and, *vice versa*, those which stand at the electro-negative end are least oxidizable.

We are doubly justified, then, in choosing zinc as one conductor, and copper, silver, platinum, or carbon (graphite) as the other.

The excitant liquid should possess two properties—it should be capable of chemically acting on the oxidizable conductor ; it should be a conductor of electricity, or electrolyte.

Water acidulated with sulphuric acid, or a solution of ammonium chloride or of common salt, will answer the purpose.

Place a piece of pure zinc and a piece of pure copper

in a glass vessel three-parts filled with a 10 per cent. solution of sulphuric acid. So long as the two metals are not brought into contact, no change will be observed. If we let them touch, or if we connect them together by a

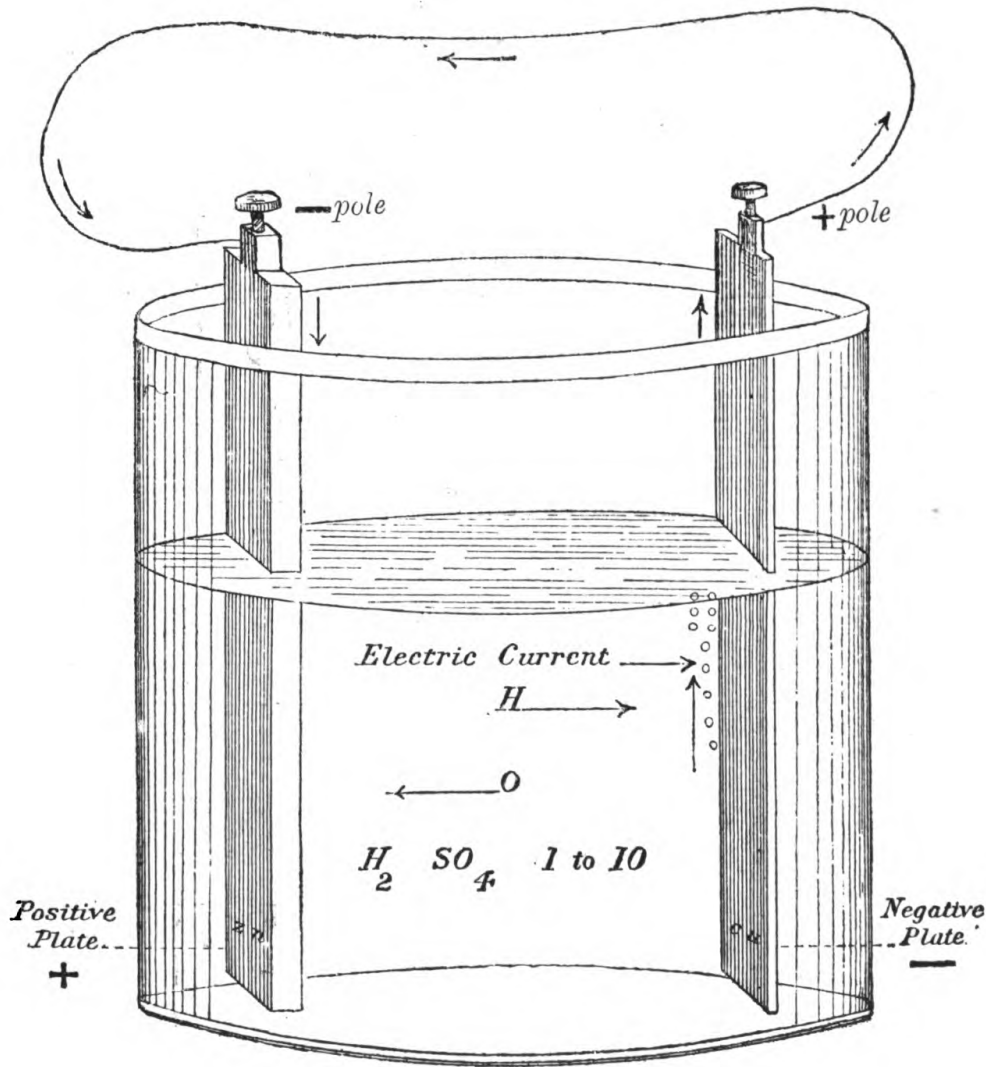

FIG. 12.—SIMPLE CELL.

wire, the zinc will be slowly dissolved by the acid, and bubbles of hydrogen will appear at the surface of the copper plate, while a current of electricity will flow across the connecting-wire.

By bringing the two metals into contact we establish a



potential difference between them—that is, we electrify one plate positively and the other negatively—and as there is in all unequal distribution of forces a universal tendency towards equilibrium, an electrical current passes from the plate at the higher potential to that at the lower. This current flows from the zinc to the copper through the liquid, and from the copper to the zinc through the wire.

Owing, however, to the chemical changes which accompany its passage through the liquid, a fresh potential difference is set up between the plates, which is again followed by an equilibrating flow, and this by a further chemical change and consequent potential difference and another equilibrating flow.

A persistent redistribution of electricity, giving rise to a continuous current in the circuit, is in this way kept up.

We may suppose that the electricity is liberated at the surface of the zinc which is in contact with the electrolyte; it is carried through this fluid to the copper, and tends to accumulate at its free extremity; if, however, the copper be joined to the zinc by a wire, it will flow along it (across it, properly speaking) to the zinc, thus completing its circuit (Fig. 12). Unless a complete circuit be provided the current cannot flow.

#### **How can the Presence of the Current be ascertained?**

By the various effects which it can produce. These may be grouped under the headings—thermal, magnetic, chemical, and physiological.

If, for instance, it be caused to flow through a thin wire, it will heat it; if through a galvanoscope or galvanometer, it will deflect the needle; if through a suitable liquid, it will decompose it; if through the tongue, tingling and burning sensations will be experienced.

#### **Length and Duration of the Current.**

It might be supposed that such a current would continue until all the zinc or excitant fluid were used up.

If, however, the experiment were tried with a galvano-

meter in the circuit by which to observe the strength of the current, it would be found after a very few minutes that the strength of the current was growing less and less, and that it might eventually even stop altogether; the cell has become polarized.

### Polarization.

The explanation of this phenomenon will be best understood by studying the action that goes on in the cell.

The acidulated water in the presence of the oppositely electrified zinc and copper is decomposed into oxygen and hydrogen; the oxygen unites with the zinc to form zinc oxide, which is further acted upon by the sulphuric acid to form zinc sulphate. The hydrogen is given off at the copper, and collects upon it.

The general action may be represented by the equation—

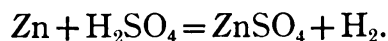

Polarization is due principally to the accumulation of the hydrogen on the copper; this weakens the current in two ways. The film it forms on the copper practically converts the copper from a copper into a hydrogen plate, and this being electro-positive to the zinc and oxygen, tends to set up a current in the reverse direction to the original one. The film on the copper offers a resistance to the original current.

Were it not for polarization, the current would continue for a considerable length of time, and its eventual diminution would be chiefly due to the consumption of the acid and zinc, and to the accumulation of the sulphate of zinc.

A means to prevent polarization is therefore of the first importance, and the various cells which are now in favour depend for their utility more or less upon the perfection of the means whereby this is prevented.

### Electrical Terms.

The parts of the cell are named as follows: The zinc plate, which is acted upon by the acid, is the *positive*

plate ; it is, we may suppose, the starting-point of the current. The copper plate, upon which the electricity collects, and which plays a passive part, is the *negative* plate. The fluid is the *excitant* and *conductor*, or *electrolyte*.

So much for the *internal* parts of the cell.

**Externally.**—The extremity of the zinc plate, to which the wire is attached, and to which the electricity returns from the copper, is termed the *negative* (–) *pole* ; while the extremity of the copper, from which the wire to the zinc passes, and from which the electricity flows, is the *positive* (+) *pole* (see Fig. 12).

The circuit is said to be closed or made when the wire is attached without a break in it to both the copper and the zinc, and to be opened or broken when there is no continuous conductor between the two.

The electrical units of measurement with which we are chiefly concerned are the *volt*, *ampère*, *ohm*, and *coulomb*. The *volt* is the unit of electro-motive force ; by the latter term we mean the force which tends to *move* electricity, to cause a current to flow, and to overcome any resistance that may be offered to the flow. It takes its origin in the difference of electric potential set up by the contact through the wire of the zinc and copper in the cell we have been describing.

A convenient standard of electro-motive force is that afforded by the Daniell cell, for this possesses sufficiently accurately for our purposes the electro-motive force of one volt.

The *ampère* is the unit of current-strength, and the latter is the *amount* or *quantity* of electricity passing any point in a circuit in one second. An electro-motive force of 1 volt driving electricity through a resistance of 1 *ohm* furnishes a current-strength of 1 *ampère*. But as this represents a strength far in excess of what is required for medical purposes, it has been conveniently divided into milliamperes, each of which represents a thousandth part of an *ampère*. A *milliampère* (0.001 ampère) is the current-strength which would be furnished

by one Daniell cell (1 volt) through a resistance of 1,000 ohms.

The *ohm* is the unit of resistance, and by resistance we mean that which in any circuit opposes the passage of the current. Thus a stout piece of copper wire offers but very slight resistance; platinum wire offers more resistance; and the human body a very great resistance, usually considerably more than 1,000 ohms. But to complete the circuit the current has not only to flow from the copper to the zinc through the wire or human body, but it has to also flow from the zinc to the copper through the excitant fluid in the cell.

The total resistance in any circuit is therefore divided into an 'external' and into an 'internal' resistance; by the former we mean the resistance the current encounters outside the cell, and by the latter the resistance it encounters in traversing the liquid in the cell. These respective resistances are usually indicated by  $R$  and  $r$ .

The legal ohm is equivalent to the resistance which is offered by a column of mercury 1 square millimetre in section (about  $\frac{1}{20}$  of an inch), and 106 centimetres (about  $41\frac{1}{2}$  inches) long, at a temperature of  $0^{\circ}$  Centigrade.

The *coulomb* is the unit of the *quantity* of current. We may deliver water into a cistern through a large pipe and in a big stream, or through a very small pipe and in a narrow stream; now, the size of the stream would be measured in electrical terms in *ampères*, but the quantity delivered per second in *coulombs*.

The standard value of the coulomb is equivalent to the quantity of electricity that will flow through or into a body when a current-strength of 1 ampère is maintained for one second.

A current of 100 milliampères flowing for ten seconds would furnish 1 coulomb.

The number of coulombs that have been administered can therefore be found by multiplying the current-strength in ampères by the time in seconds.

To take an ordinary case. Suppose a patient has had

a current of 10 milliampères strength passed through his body for five minutes. How many coulombs have been administered ?

The sum will be  $5 \times 60 \times .01 = 3$ .

Chiefly owing to the variations in the strength of the current that are constantly occurring in electrical treatment, the coulomb has not been much used by medical men. Its importance lies in the fact that it compels a recognition of the element of time.

**Ohm's Law.**—The main key to a proper understanding of electro-physics, and therefore the first step in rational electro-therapeutics, is a firm grasp of this law. Dr. G. S. Ohm, in 1827, laid down the following law : ' The strength of the current varies directly as the electro-motive force, and inversely as the resistance of the circuit ' ; *i.e.*, the current-strength in ampères is equal to the electro-motive force in volts divided by the resistance in ohms. As an equation :

$$\frac{\text{Electro-motive force in volts}}{\text{Resistance in ohms}} = \text{current-strength in ampères.}$$

By the resistance is meant the whole resistance, both external and internal, of the circuit.

If we take E to represent the electro-motive force in volts, R to represent the external, and  $r$  the internal resistance in ohms, we can then express it :

$$\frac{E}{R+r} = \text{ampères.}$$

Take as an example a Daniell cell, with an electro-motive force of 1 volt, and suppose its current to be passing through a circuit whose total resistance is 1 ohm, then the strength of the current will be 1 ampère, for :

$$\frac{1 \text{ volt}}{1 \text{ ohm}} = 1 \text{ ampère.}$$

Let the resistance be raised to 2 ohms :

$$\frac{1 \text{ volt}}{2 \text{ ohms}} = .5 \text{ ampère.}$$

Suppose it to be raised to 1,000 ohms, then :

$$\frac{1 \text{ volt}}{1,000 \text{ ohms}} = 1 \text{ milliampère} = 0.001 \text{ ampère.}$$

Further, if we know any two of the factors of the equation, we can determine the third ; for ' the electro-motive force in volts is equivalent to the current-strength in ampères multiplied by the resistance ' :

$$E = \text{ampères} \times (R + r),$$

and ' the total resistance in ohms is equivalent to the electro-motive force in volts divided by the current-strength in ampères ' :

$$R + r = \frac{E}{\text{ampères}}$$

The practical application of Ohm's law will be deferred until we have examined the various types of galvanic cells.

Electrical currents, in common with static charges, always possess two qualities : that of pressure or tension measured in volts, and that of amount or volume. measured, in the case of currents, in ampères.

The so-called forms of electricity only differ from each other by the various degrees in which they possess these qualities.

Thus, an ordinary medical battery may furnish us through the human body with a current-strength of 10 milliampères under a pressure of 50 volts.

A cautery battery with a current-strength of 10 ampères under a pressure of 2 volts.

A dynamo machine with a current of 20 ampères strength under a pressure of 100 or more volts.

A frictional machine with a current-strength of  $\frac{1}{100}$  of a milliampère under a pressure of 50,000 volts.

If these qualities be measured and multiplied together we obtain the unit of electrical power, *the Watt*. One thousand Watts are termed a ' kilowatt. '

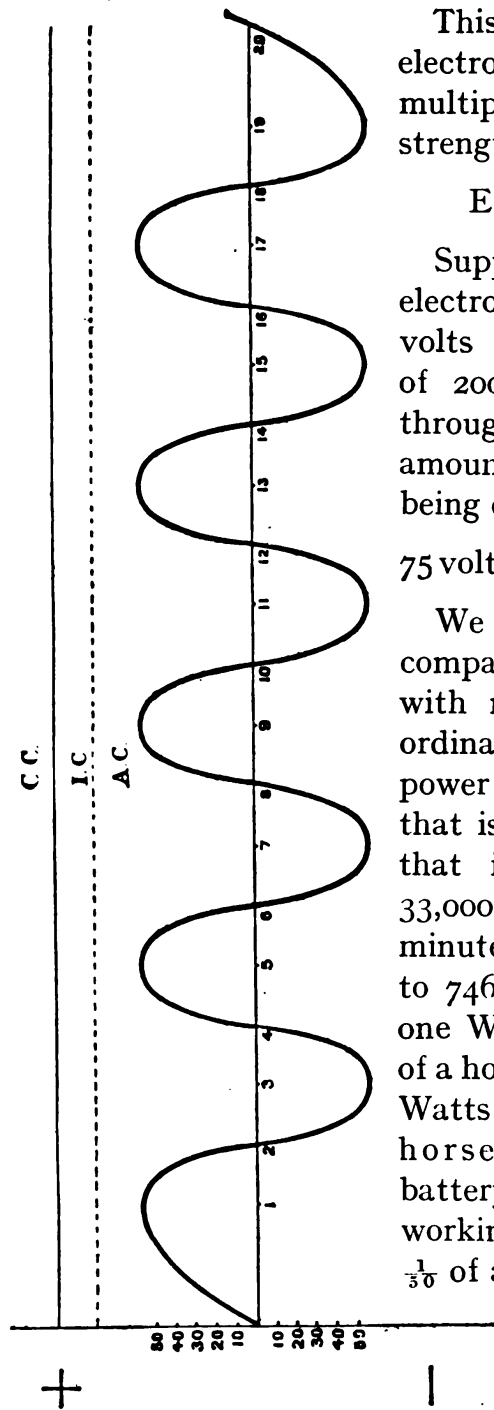

FIG. 13.—CURVES AND LINES.  
 Representing: C.C. continuous current;  
 I.C. interrupted current ; A.C. alternating current.

This is the product of the electro-motive force in volts multiplied by the current-strength in ampères.

$$E \times \text{ampères} = \text{Watts.}$$

Suppose a battery with an electro-motive force of 75 volts be sending a current of 200 milliampères strength through a fibroid tumour, what amount of electrical power is being expended ?

$$75 \text{ volts} \times .2 \text{ ampères} = 15 \text{ Watts.}$$

We are now in a position to compare our electrical power with mechanical power. The ordinary unit of mechanical power is the horse-power, and that is equivalent to the force that is expended in raising 33,000 lb. 1 foot high in one minute. It is also equivalent to 746 Watts ; that is to say, one Watt is equivalent to  $\frac{1}{746}$  of a horse-power. Hence fifteen Watts =  $\frac{15}{746}$  horse-power =  $\frac{1}{50}$  horse-power, nearly. Our battery would therefore be working at the rate of about  $\frac{1}{50}$  of a horse-power.

Electrical currents may also be :

1. Continuous.
2. Interrupted.
3. Alternating.

The term 'con-

tinuous' is applied to a current that flows steadily without interruptions in one direction, such as the current furnished by galvanic cells or accumulators.

The interrupted current is one that also flows in one direction, but intermittently, such as the primary current of an induction coil, or that of a direct current dynamo, though if the latter be driven at a high speed the interruptions become imperceptible, and the current almost continuous.

The alternating current is one that is always changing its direction. The current at first passes in one direction, making one pole positive and the other negative, and then is instantly reversed so as to pass in the other direction, the positive pole now becoming the negative, and *vice versa*; and these changes occur very many times in a minute. This is the type of current yielded by the secondary coils of induction machines and alternating current dynamos.

Fig. 13 depicts graphically the three types of current. Let the base line represent the time, the vertical line the current-strength, then the line C.C. will represent a continuous current flowing steadily in one direction; the line I.C., the interrupted current flowing intermittently in one direction; the line A.C., the alternating current flowing first in one direction and then in the other and passing through zero between each reversal.

Electrical power is now measured commercially in Board of Trade units. One B.T. unit = 1,000 Watt hours = 1 kilowatt hour = 1,000 volt ampère hours = 1.34 horse-power for one hour. A current of 10 ampères strength at a pressure of 100 volts for one hour would consume one Board of Trade unit. The charge for this varies from about 2½d. to 9d.



## CHAPTER IV

### FORMS OF PRIMARY CELLS

CELLS can be divided into two classes :

- A. Those with single fluids.
- B. Those with double fluids or *constant* cells.

Amongst the single fluid cells are the Smee, the Leclanché, the single-cell bichromate, and certain so-called dry cells. Amongst the double fluid are the Daniell, the Grove, and the Bunsen.

The simple cell we have already described may be taken as the type of the single fluid cells. Its current fails so rapidly through polarization that it is of little use. Various means have been employed to prevent the internal polarization of cells. Thus, the hydrogen may be oxidized before it can attach itself to the negative plate by oxidizing agents (nitric acid, chromic acid, etc.) ; or it may be made to turn copper out of a solution of sulphate of copper, so that the copper is set free at the negative plate instead of the hydrogen ; or it may be removed mechanically by agitating the liquid, or by roughening the surface of the plate at which it is given off.

The plates or elements in the cells, which will now be described, are respectively termed *positive* and *negative* according to the action that is supposed to go on in the cell ; but it must be remembered that the *positive plate* has the *negative pole* attached to it, and *vice versa*.

#### The Smee Cell.

(a) The 'electrolyte' is a dilute, 1 to 10, solution of sulphuric acid.

(b) The 'positive plates' (negative pole) are of amalgamated zinc (see p. 106), and are placed one on each side of the negative plate.

(c) The 'negative plate' (positive pole) is of platinized silver (a thin sheet of silver covered with platinum in a fine state of division).

There are two objects in so treating the silver.

1. Platinum as opposed to zinc has a higher electro-motive force than copper; it is more electro-negative.

2. The plate, owing to its platinization, has a rough surface to which the hydrogen is not so well able to adhere as it is to a smooth one.

The depolarizer in this cell is therefore a mechanical one. The 'electro-motive force' varies from about 0.75 to 1 volt.

Owing to the imperfect means for preventing polarization, the current is not constant, while unless the zinc be withdrawn from the solution when the cell is not being used, it will be slowly acted on and worn away. The chemical action is that of the simple cell. It is not a suitable cell for medical purposes.

### The Leclanché Cell.

The Leclanché cell is of far more importance (Fig. 14).

(a) The 'electrolyte' is a strong solution of ammonium chloride, which half fills a glass jar.

(b) The 'positive element' is a rod of amalgamated zinc.

(c) The 'negative element' is formed of a rod of carbon surrounded by coarsely-powdered carbon and peroxide of manganese, all enclosed in a porous pot which stands in the glass jar.

(d) The 'depolarizer' is the manganese peroxide.

The 'electro-motive force' (E. M. F.) is about 1.47 volts, and the internal resistance of the cells varies from about 1 to 5 ohms.

During action the ammonium chloride attacks the zinc

### 36 A MANUAL OF PRACTICAL MEDICAL ELECTRICITY

to form zinc chloride, ammonia and hydrogen being set free.

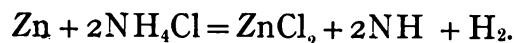

The ammonia dissolves in the water (1 volume of water can absorb more than 700 volumes of ammonia at the ordinary temperature) until it is saturated, when the gas escapes.

The hydrogen appearing at the negative element unites

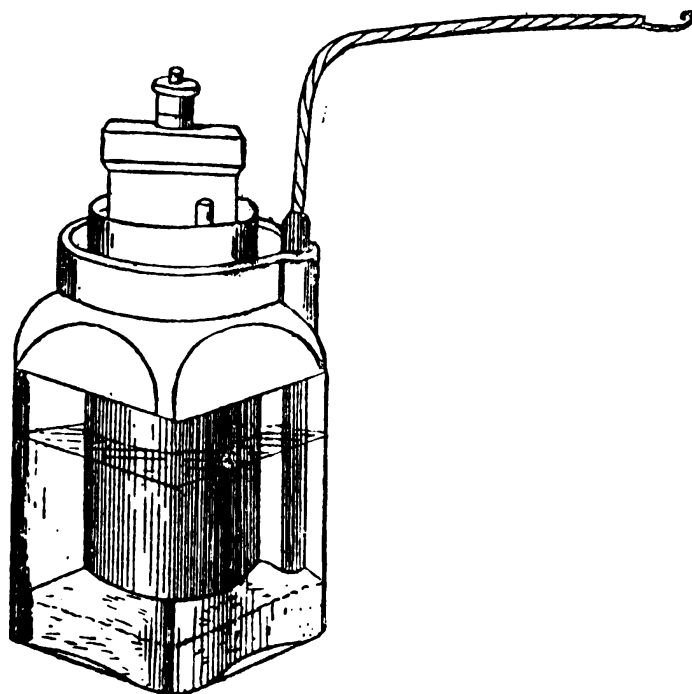
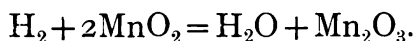

FIG. 14.—LECLANCHÉ CELL.

with some of the oxygen of the manganese peroxide to form water, the peroxide being reduced to the sesquioxide.



The manganese peroxide thus acts as the depolarizer, the cell becoming inefficient when it is all reduced. Further, as the resulting sesquioxide is a poor conductor of electricity, and as there is a tendency to the formation of double salts which crystallize on the zinc, the internal resistance gradually increases, and the chemical action

diminishes, even if we leave the weakening of the ammonium chloride solution due to its decomposition out of account.

A peculiarity of this cell is the rapidity with which it becomes temporarily polarized when short-circuited—that is, when its poles are put into metallic connection with only a low external resistance. The manganese seems to be unable to depolarize sufficiently rapidly to keep pace with the amount of hydrogen liberated; the current, therefore, quickly falls off. On the other hand, it recovers itself very rapidly when the circuit is broken.

This temporary polarization, it is to be noted, only occurs when the cell is short-circuited (permitted to work at full power without having a proper load). No great objection can be taken to it on that score so far as regards our purposes.

The resistance of the human body is so great that but little chemical action is permitted. The manganese can keep pace with the hydrogen, and for the length of an ordinary séance a practically constant current can be obtained.

The chief advantage of this cell is its durability. No chemical action goes on when it is idle; the zinc need not be withdrawn from the solution; if put away for a week, a month, or longer, it will be found in exactly the same condition, and even at the end of a year all that it will probably require will be a little water. To medical men, this is of paramount importance.

Attempts have been made to lower the internal resistance of the Leclanché cell by dispensing with the porous pot. In the agglomerate form, the carbon element and the peroxide of manganese are consolidated together by great pressure, after addition of some resinous material, and the porous pot is not required.

Mr. Schall places the zinc inside an agglomerate cylinder of carbon (Fig. 15); this materially reduces the internal resistance (often under 1 ohm). The zinc is prevented from touching the carbon at its lower extremity by an

indiarubber ring, and it is supported above by a disc of wood or a rubber cork, which fits the mouth of the cell pretty closely, and tends to lessen evaporation and the creeping over of the salts.

The Leclanché cell is probably the best one at present

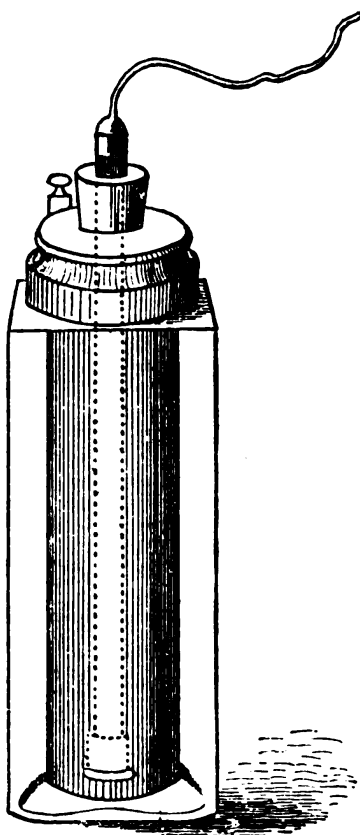

FIG. 15.—LECLANCHÉ-BARBIER CELL OF LOW INTERNAL RESISTANCE.

known for furnishing a galvanic current for medical treatment. Its advantages are :

1. It requires scarcely any looking after.
2. It will last with fair use for an indefinite period.
3. It does not deteriorate through inactivity.
4. Though it polarizes rapidly on short circuit, yet it will yield during ordinary galvanization a practically constant current for from ten to twenty minutes.
5. It is cleanly, and it yields no fumes.

It is better in charging the cell to dissolve the sal-ammoniac (which should be pure) in warm water in a jug, and to half fill the cell with it when it is cold. The solution may be made of any strength, from half saturation to saturation; the weaker it is, the less tendency there is for the salts to creep over the sides of the jar.

In filling the cells, care should be taken not to moisten the sides of the jar with the solution, and it is well to coat the upper margins of the sides with vaseline or paraffin. The cells should be kept preferably in a cool place to diminish evaporation, and a little water should be occa-

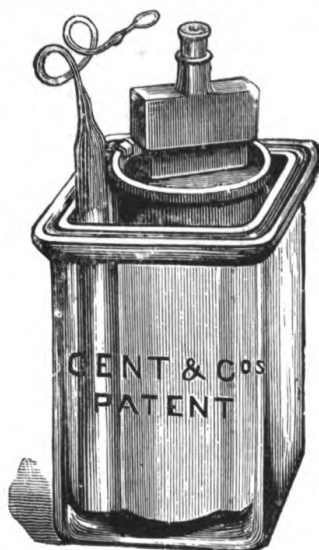

FIG. 16.—INSULATED LECLANCHÉ.

sionally added. Fig. 16 is that of an insulated cell or jar, in which a recess surrounds the top of the vessel filled with a material to which the salts will not adhere.

#### The Grenet or Bichromate of Potash Cell.

(a) The 'electrolyte' is a solution of sulphuric acid and bichromate of potash or chromic acid.

(b) The 'positive element' is made of a plate of zinc.

(c) The 'negative element' of two plates of carbon which lie on either side of the zinc.

(d) The 'depolarizer' is the chromic acid.

#### 40 A MANUAL OF PRACTICAL MEDICAL ELECTRICITY

The E. M. F. is about 2 volts, and the internal resistance less than 1 ohm. The current-strength is accordingly great, for, according to Ohm's law (on short circuit) :

$$\frac{2 \text{ volts}}{1 \text{ ohm}} = 2 \text{ ampères.}$$

Various formulæ are given for preparing the exciting solution. The following is one of them :

Dissolve 1 part by weight of powdered bichromate of potash in 9 parts by weight of hot water : when it is nearly dissolved and quite cold, add slowly  $2\frac{1}{2}$  parts by weight of strong sulphuric acid, stirring all the time. Twenty-five grains of persulphate of mercury may afterwards be added to every pint of the solution to preserve the amalgamation of the zinc plate.

Another formula is as follows :

Take of water, 1,000 c.c. ; of potass. bichromate, 100 grammes ; of sulphuric acid, 150 c.c.

If chromic acid be used instead of bichromate of potash, 4 ounces of the acid can be dissolved in 1 pint of water, and 3 ounces of sulphuric acid cautiously added, with constant stirring.

Depolarization can be assisted by the addition of a little chlorate of potash ( $\frac{1}{2}$  ounce to every pint of any of the above solutions).

Chromic acid is more expensive than the bichromate, but it presents several advantages : thus, being much more soluble, the solution can be made much stronger in regard to its depolarizing power ; half the sulphuric acid added to a bichromate solution is required to combine with the potash to form sulphate of potassium ; the chromic acid solution is thus stronger in its excitant action ; lastly, the double salt chrome alum is not formed when chromic acid is used.

The bichromate of soda may be used instead of the potash salt.

A convenient means of preparing the solution, and of avoiding the trouble of handling the corrosive sulphuric

acid, is afforded by the crystals of the combination of the acid with the bichromate of potash; 7 ounces of the crystals should be dissolved in 2 pints of water, and the solution is ready. The crystals can be purchased at most electrical instrument makers.

As a result of the mixture of bichromate of potash, sulphuric acid and water, we obtain potash sulphate and chromic acid.

The chemical action when the circuit is closed is that

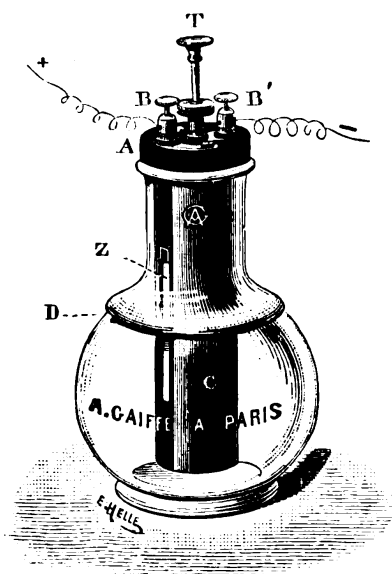

FIG. 17.—BOTTLE BICHROMATE CELL.

the sulphuric acid reacts with the zinc to form zinc sulphate, liberating hydrogen; this is oxidized by the chromic acid, in the presence of sulphuric acid, into water, with the formation of chromic sulphate, and, if the potash salt has been used, later of chrome alum.

The principal reactions may be expressed as follows :

- (a)  $\text{Zn} + \text{H}_2\text{SO}_4 = \text{ZnSO}_4 + \text{H}_2.$
- (b)  $\text{K}_2\text{Cr}_2\text{O}_7 + 4\text{H}_2\text{SO}_4 = \text{Cr}_2(\text{SO}_4)_3 + \text{K}_2\text{SO}_4 + 4\text{H}_2\text{O} + \text{O}_3.$
- (c)  $\text{H}_2 + \text{O} = \text{H}_2\text{O}.$
- (d)  $\text{Cr}_2(\text{SO}_4)_3 + \text{K}_2\text{SO}_4 + 24\text{H}_2\text{O} = \text{chrome alum}.$



This cell is frequently sold in a bottle form, with an arrangement for lifting out the zinc (Fig. 17), and it is useful for furnishing strong currents for short periods, *e.g.*, as in working an induction coil.

It is also one of the most suitable primary cells we possess for heating the cautery or lighting small incandescent lamps. For these purposes several cells are usually combined to form a battery (Fig. 18).

In all forms there must be an arrangement for lifting the zincs out of the solution so soon as the current is not

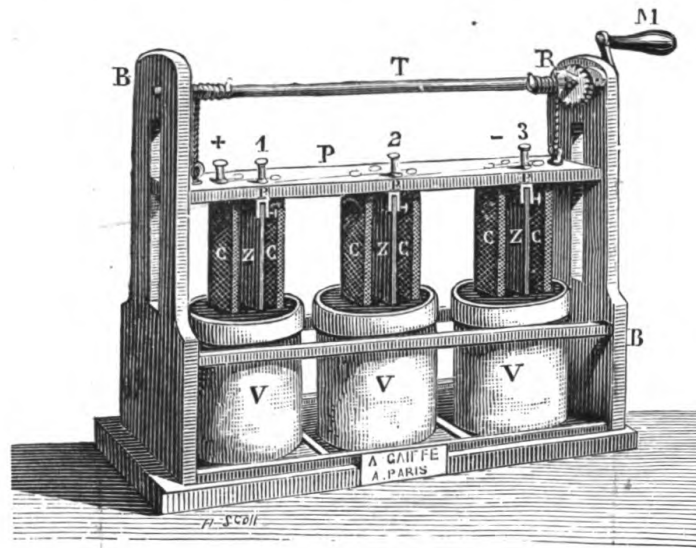

FIG. 18.—BICHROMATE BATTERY.

required, because the zinc is slowly dissolved, even when the circuit is not completed.

Depolarization is very effective at first, but soon fails unless the liquid be constantly agitated. Thus, if the current from the bottle cell seem to fail, it can be strengthened by shaking the bottle, or by raising and lowering the zinc.

Stöhrer's battery, though formerly intended to be used with dilute sulphuric acid, like a Smee, is now practically made up of a number of ordinary bichromate cells, with a convenient lifting arrangement for the vessels.

### The Marie Davy or Persulphate of Mercury Cell.

Of this there are several forms.

- (a) The 'electrolyte' is a solution of the persulphate of mercury.
- (b) The 'positive element' is of zinc.
- (c) The 'negative element' is of carbon.
- (d) The 'depolarizer' is the persulphate of mercury.

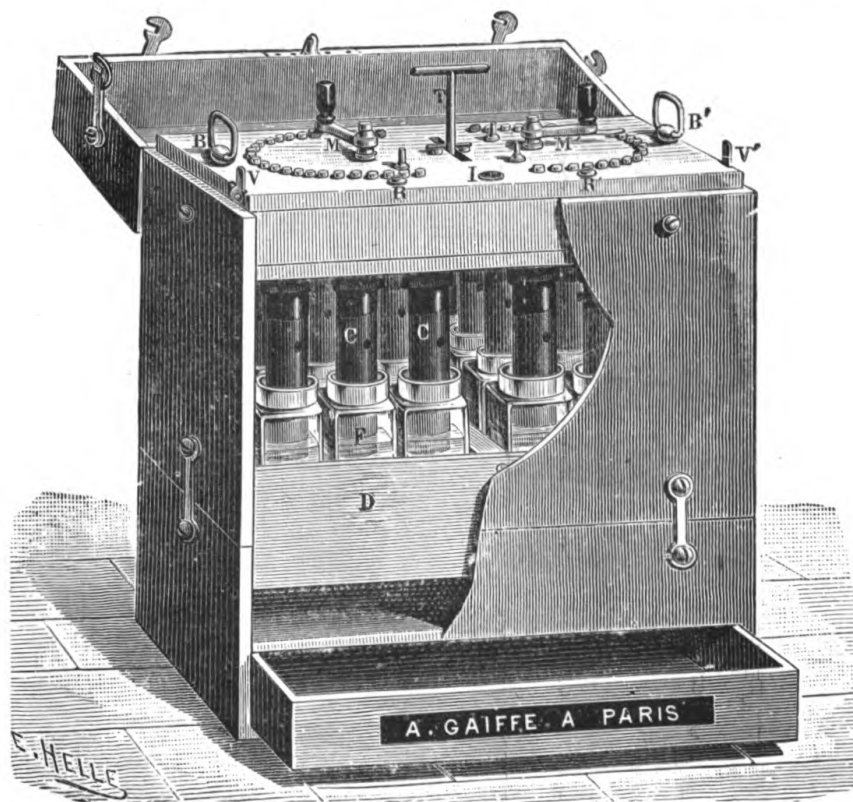

FIG. 19.—PERSULPHATE OF MERCURY CELL BATTERY.

The E. M. F. is about 1.5 volts. The internal resistance is low.

During action, the zinc decomposes the water, yielding hydrogen, which, appearing at the carbon, displaces the mercury, to form sulphuric acid and metallic mercury; the former attacks the zinc, while the latter collects at the bottom.

In the old form, the cell resembled the Daniell, and had a porous pot, the sulphate of mercury taking the place of the sulphate of copper, and the carbon that of the copper. The porous pot is dispensed with in the later forms.

Gaiffe uses a divided ebonite trough to form two small cells. The carbon plates are placed at the bottom of the trough, and are smeared over with a paste of sulphate of mercury; the zincs form lids which lie over them.

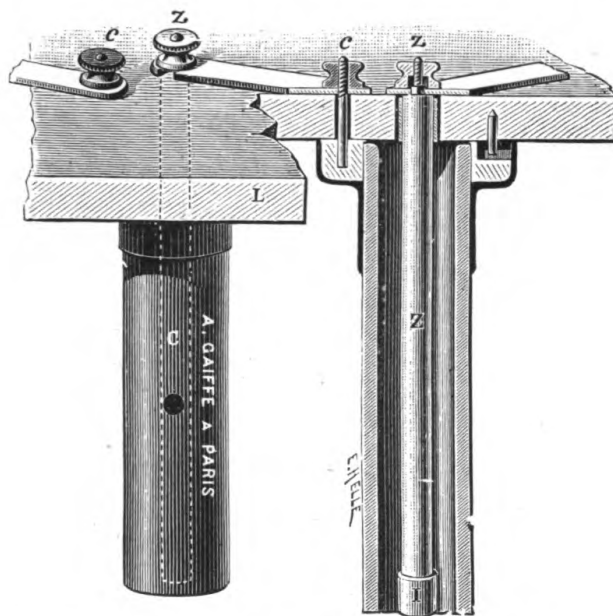

FIG. 20.—ARRANGEMENT OF ZINC AND CARBON.

In Schanschiff's cell there are two carbons to each zinc, and a strong solution of the basic sulphate is the excitant.

In some of the later forms of sulphate of mercury batteries there is an arrangement for raising or lowering the elements out of or into the solution, according to the strength of current required, and, to insure portability, the vessels are provided with floating ebonite pieces to prevent spilling of the acid solution (Figs. 19 and 20).

Gaiffe also sells the excitant in the form of a salt, which has only to be dissolved in water.

The small cells of Gaiffe are suitable for working in-

duction coils, the larger cells for galvanization and other purposes.

This battery has found much favour in France ; it is asserted that it is very constant, that it gives off no fumes, that the zincs are kept constantly amalgamated by the mercury which is precipitated in the cell during action, and that, while the E. M. F. is the same as that of the Leclanché, depolarization is more perfect.

### Dry Leclanché Cells.

The Obach and Hellesen are forms of dry cell manufactured by Siemens and Co., and supplied for medical purposes by Schall (Figs. 21 and 21A).



FIG. 21.—THE OBACH CELL.

(a) The composition of the 'electrolyte' is a secret, but it appears to consist of a paste containing ammonium chloride.

(b) The 'positive element' is a cylinder of zinc.

(c) The 'negative element' is of carbon, which stands in the centre of the zinc cylinder.

(d) The 'depolarizer' consists partly of binoxide of manganese, which is contained in a bag surrounding the carbon.

The E. M. F. is about 1.47 volts, and the internal resistance in the number two size 0.25 ohm, and in the number six, or smallest portable medical size, 0.65 ohm.

Of these cells very good reports are forthcoming. Along with great freedom from polarization, they possess a

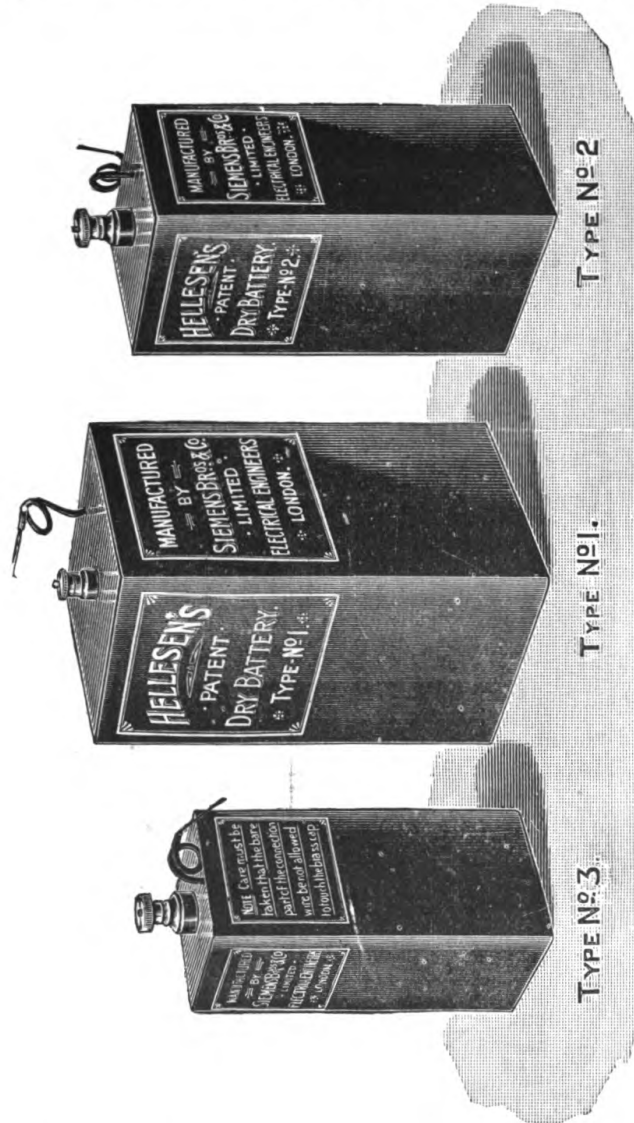

FIG. 21A.—HELLESEEN CELLS.

marked power of recovery. Mr. Shelford Bidwell, F.R.S., who has put a Helleesen cell to an exhaustive test, finds that the number two size will give on short circuit through a galvanometer, with a total external resistance of 0.005 ohm, a current of more than 12 ampères strength.

Two of this size connected in parallel, serve in my own hands to bring a short platinum cautery to a white heat. Eight to ten of the smallest size connected in series will bring a laryngoscopic lamp to full incandescence, and, if in parallel, will heat for a very short period a cautery.

Further, the cell is exceedingly portable ; containing no liquid, it cannot be upset. Failure owing to evaporation, or to short-circuiting through creeping of salts outside the vessel, cannot occur. There is no action when the cell is not in use ; the zincs have not to be lowered when the current is required, to be raised again immediately afterwards.

The small cells measure  $1\frac{1}{2} \times 1\frac{1}{2} \times 3\frac{3}{4}$  inches, and weigh 8 ounces each. All forms of dry cells are modifications of Leclanché cells, and none of them are as reliable as the ordinary form of wet cell, although when fresh they are remarkably efficient. Whether current is drawn from them or not, they, however, slowly become useless, mainly owing to an increase in their internal resistance.

### Double Fluid Cells.

The only really constant cells are the two liquid ones, and of these the Daniell is the most important.

(a) The 'electrolyte' is a dilute (1 to 20 or 40) solution of sulphuric acid, usually contained in a porous pot.

(b) The 'positive' plate is of zinc, which lies in the excitant solution.

(c) The 'negative' plate is of copper.

(d) The 'depolarizer' is a saturated solution of sulphate of copper.

The E. M. F. is roughly equivalent to 1 volt. The internal resistance is somewhat high, varying from about 2 to 10 or more ohms, according to the size and form of the cell.

The chemical changes are very simple. The zinc dissolves during action in the excitant solution to form zinc sulphate, while hydrogen is set free ; the latter, appearing

at the junction of the two liquids, displaces the copper from its solution to form sulphuric acid and metallic copper ; the acid passes back to the zinc, and the copper is deposited upon the negative plate.

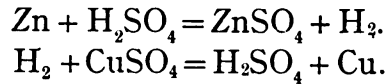

There is, it will be observed, no consumption of sulphuric acid ; for every molecule of the acid that is decomposed by the zinc within the porous pot, one molecule of the acid is formed by the hydrogen displacing the copper outside the porous pot.

In the case of the electrodes the zinc slowly dissolves with the formation of zinc sulphate, which continually increases ; the copper is slowly added to by the deposition of metallic copper at the expense of the cupric sulphate, which continually decreases.

It is therefore necessary, in order to maintain the cell in constant action, to keep up a constant supply of copper sulphate, and from time to time to renew the zinc and remove the waste products which accumulate in the porous pot.

By keeping an excess of the copper sulphate crystals in the solution, its strength is automatically maintained, the crystals dissolving as the copper is removed.

The zincs should in this, as in the other cells already mentioned, be kept well amalgamated. (This is not of such importance in the Leclanché type.)

In the ordinary form of Daniell (Fig. 22), the vessel wall is of copper, A (transparent in the figure to show the internal arrangement), and itself forms the negative plate ; it contains a saturated solution, C, of copper sulphate, and within it stands the porous pot, B, which contains the electrolyte and the zinc ; the latter is maintained in position by being passed through a disc of hard wood, which forms a lid to the pot.

In another form (Fig. 23), the outer vessel is made of glass, and the zinc is formed of a heavy cylinder placed

within the porous pot, the copper of a split cylinder without it.

In the gravity cell (Fig. 24), the porous pot is dispensed with, and the two liquids are prevented from mixing by their different specific gravities.

A star-shaped copper plate rests at the bottom of a glass vessel, and is connected with the exterior by a heavily insulated copper wire. The vessel is half filled with a saturated solution of copper sulphate, and plenty of extra crystals are also added. A heavy piece of zinc

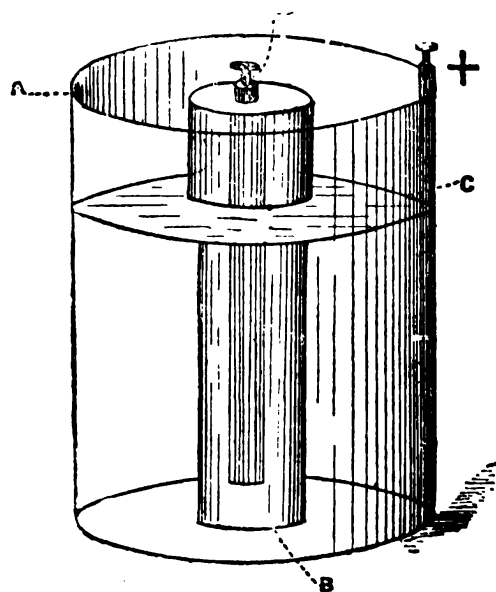

FIG. 22.—DANIELL CELL.

is suspended in the upper part of the cell. The vessel can be filled up either with the copper sulphate, or with a dilute solution of zinc sulphate or of sulphuric acid.

If the cell be only occasionally required, it will be preferable to use the Minotto type, in which the space between the zinc above and the copper sulphate below is filled with sawdust, sand, or paper pulp; this lengthens the life, but much increases the resistance. The gravity cell, from its simple and inexpensive form, is more suitable than the ordinary Daniell for a house installation.



If left quite undisturbed it will furnish a constant current for many weeks ; it is also fairly clean, and is free from fumes, and when the cell is not in use, the internal

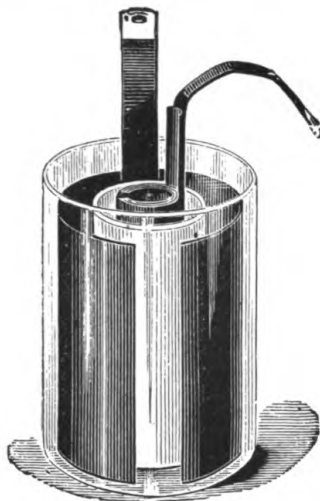

FIG. 23.—DANIELL CELL.

action is slight. The E. M. F. is, however,  $\frac{1}{2}$  volt less per cell than that of the Leclanché type ; ten of the latter have as much E. M. F. as fifteen of the former (an

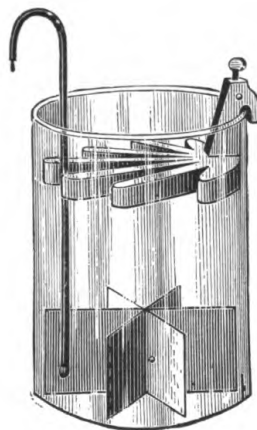

FIG. 24.—GRAVITY CELL.

important point in medical practice, where as many as forty to sixty cells are required).

Unless the cells also have regular attention, the salts

creep out, copper becomes deposited upon the porous pot, if one be used ; the copper solution also slowly makes its way through to the zinc, upon which the copper becomes deposited in a dark-coloured spongy form. Moreover, the outstanding feature of the cell, its constancy, though so essential for delicate experimental work, is not nearly so important to us as is durability without constant attention.

### The Grove and Bunsen Cells.

(a) The 'electrolyte' is a strong solution of sulphuric acid.

(b) The 'positive' plate is a cylinder of zinc.

(c) The 'negative' plate is contained in a porous pot three - parts filled with strong nitric acid, and is of platinum foil in the Grove, and a stick of carbon in the Bunsen.

(d) The 'depolarizer' is the nitric acid.

The E. M. F. is about 2 volts, and the internal resistance about 0.2 ohm. The current is therefore very strong on short circuit, for

$$\frac{2 \text{ volts}}{0.2 \text{ ohm}} = 10 \text{ ampères.}$$

During action, zinc sulphate is formed at the expense of the zinc and sulphuric acid, while the liberated hydrogen is oxidized by the nitric acid to form water and nitric peroxide, which escapes in reddish fumes.

In the figure (Fig. 25) the outer vessel is seen to be of glass ; this contains the sulphuric acid, and a cleft, heavy, well-amalgamated cylinder of zinc. The porous pot containing the nitric acid and a rod of carbon stands in the centre.

But little need be said about this form of cell here. It will furnish a very strong current, which will remain constant for two or three hours ; but the strong acids, noxious fumes, and want of durability, unless it be dis-

mounted after every use, entirely preclude it from a permanent installation. Occasionally it is still set up in a hospital for an electrolysis, or to light a lamp or heat a cautery; it is of use also in charging an accumulator. Before the invention of the dynamo, it was in frequent

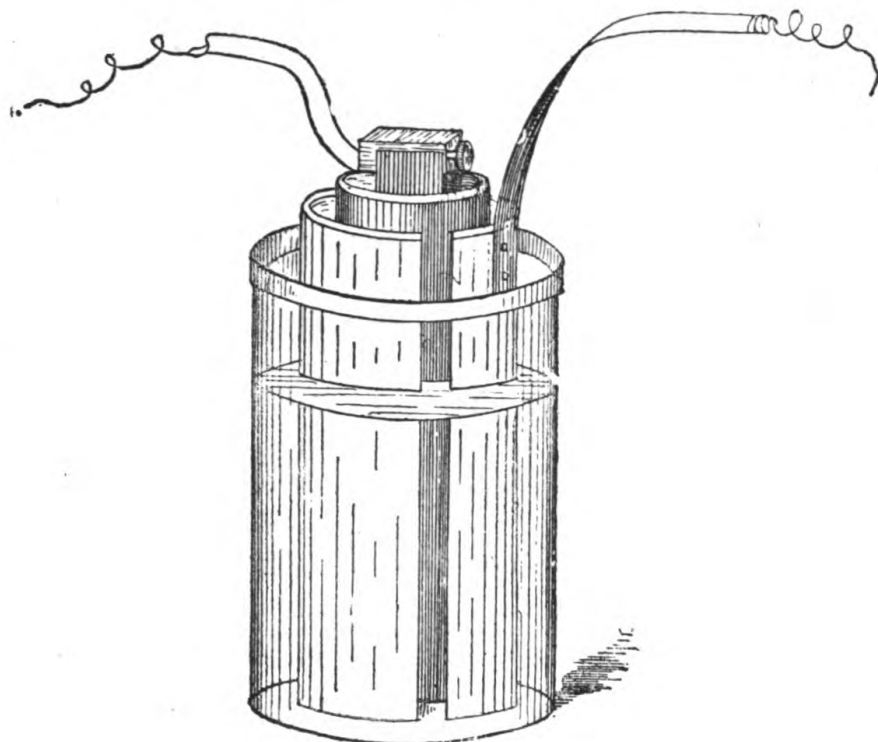

FIG. 25.—BUNSEN CELL.

demand to light an arc lamp, some fifty cells being coupled together in series.

The subject of dynamos and of batteries will be postponed until E. M. F., current-strength, resistance, and faradic electricity have been discussed.

## CHAPTER V

### ELECTROMOTIVE FORCE

WE have already seen that difference of potential gives rise to electromotive force (E. M. F.), and that E. M. F. is the power that moves electricity along, and enables it to overcome resistance. The current always flows from the point of higher potential to the point of lower potential, and it will continue if possible to flow until an equilibrium of potential is attained. The electrification of the earth is commonly taken as the standard of zero potential.

The analogy of water to current electricity is very close.

Suppose we have two cisterns equally full of water connected by a pipe, which is closed by a stopcock ; then no current will flow between them, because there is no continuous conductor. Just so electricity will not flow unless there be a conductor. Suppose the stopcock opened, and the cisterns at the same level, still no water will flow between them, because there is no lower level for the water to flow to ; to get a flow of water we require a difference of level or of head. So, too, is it with electricity : *difference of potential* corresponds to *difference of level*, or of pressure, and unless there be some difference, no current will flow, and the greater the difference the greater tendency is there for it to flow, the greater is the E. M. F. Electrical difference of potential is also analogous to difference of temperature in heat, and difference of pressure in gases. Heat flows from a hotter body to a colder one, and will continue to flow until both are at the same temperature. Gases pass from a position of greater pressure to one

of a lower pressure. The steam in a boiler may be at 20 lb. pressure per square inch or at 100, and, *cæteris paribus*, the greater the pressure the more work it will do. In like manner we may have an E. M. F. of 1 or of 1,000 volts, and the greater the E. M. F. the greater will be the electrical pressure, and, *cæteris paribus*, the stronger will be the current. In electro-therapeutics the resistance to the current is usually great, and a considerable E. M. F. is required to overcome it and to yield us a sufficient current.

### How can we increase the E. M. F. ?

We have seen that it depends upon the electrolyte and upon the nature of the plates ; it has *no relation* to the size of the cell. It follows, then, that we cannot increase it by using larger cells. A Daniell cell of ordinary size has an E. M. F. of 1 volt, and though we built one as large as a washing-tub, its E. M. F. would remain just the same. From this point of view, then, there is nothing to be gained by having large cells.

The E. M. F. can, however, be varied by changing the nature of the plates and liquid ; thus the

	<i>Volts.</i>
Smee cell has an E. M. F. of about 0·75 to	1·107
Leclanché                   "       "	1·47
Marie Davy                 "       "	1·5
Grenet                       "       "	1·9 to 2
Daniell                      "       "	1·1
Bunsen                      "       "	1·9
Hellesen                   "       "	1·47
Accumulators             "       "	2·2

### Series Arrangement.

To obtain a greater E. M. F. than any one cell can give, we must use a number of cells, and these must be connected in *series*—*i.e.*, the copper or carbon plate of one cell must be connected to the zinc plate of the next (Figs. 26 and 27).

By this arrangement the total E. M. F. of the collection

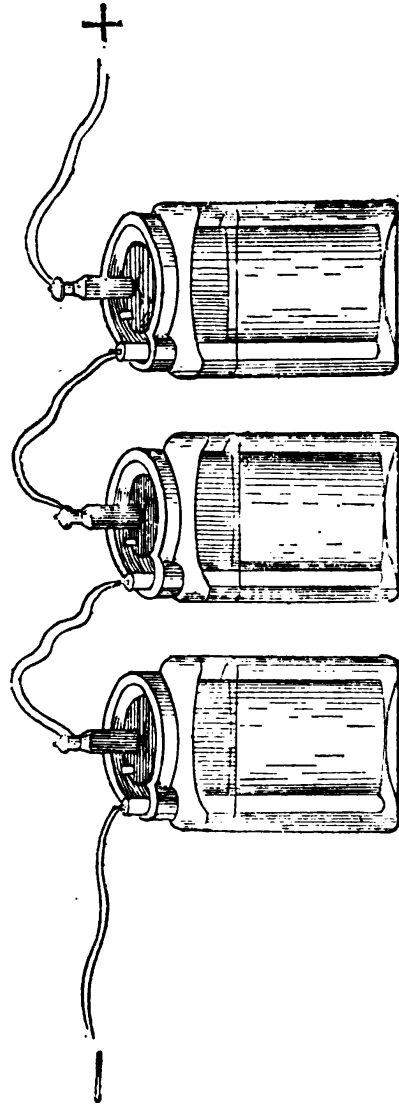

FIG. 26.—THREE CELLS IN SERIES.

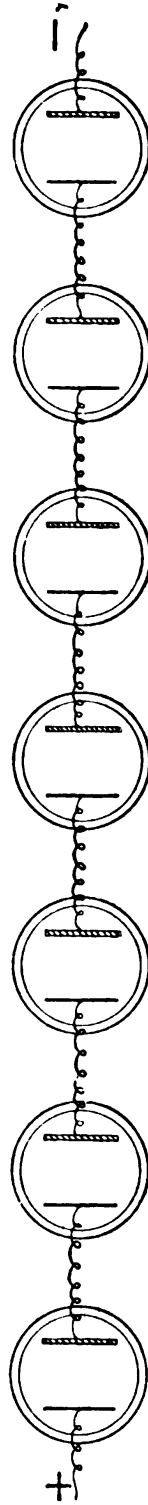

FIG. 27.—PLAN OF SEVEN CELLS IN SERIES.

of cells or battery is equivalent to the E. M. F. of each cell multiplied by the number of cells. Thus, ten Leclanché cells joined in series would give an E. M. F. of 15 volts, because 1.5 volts  $\times$  10 = 15 volts. In a similar manner, twenty Daniell cells joined in series give a total E. M. F. of 20 volts, because 1 volt  $\times$  20 = 20 volts.

As the resistance to be overcome in ordinary medical galvanization is usually very great, it becomes necessary to couple a large number of cells together in series, viz., from twenty to sixty.

### How can we measure our E. M. F.?

By Ohm's law  $C = \frac{E}{R}$ .

Likewise  $R = \frac{E}{C}$ ,

and  $E = C \times R$ .

Hence, if we know the total resistance of the circuit and the current-strength, we obtain the E. M. F. by multiplying them together.

Suppose the total resistance, both internal and external, to amount to 100 ohms, and the current-strength to 10 milliampères ; then

$$100 \text{ ohms} \times 0.01 \text{ ampère} = \text{E. M. F.} = 1 \text{ volt.}$$

Further, the greater the external resistance, the less we need consider the internal in making our calculation ; thus, if we can put a resistance of 2,000 ohms into the external circuit, yielding us a current of, say, 1 milliampère, it will matter but little whether in the case of a cell with an internal resistance of 5 ohms we add this on or not, for

$$\begin{aligned} 2,000 \text{ ohms} \times 0.001 \text{ ampère} &= 2 \text{ volts, and} \\ 2,005 \text{ ohms} \times 0.001 \text{ ampère} &= 2.005 \text{ volts.} \end{aligned}$$

A Daniell cell can be used as a standard of comparison. It has an E. M. F. of 1 volt ; then, as the current-

strength varies directly as the E. M. F., and inversely as the resistance, all we need do is to pass the current from our cells, and from the Daniell, through a milliampère meter with a definite high resistance in the circuit. The

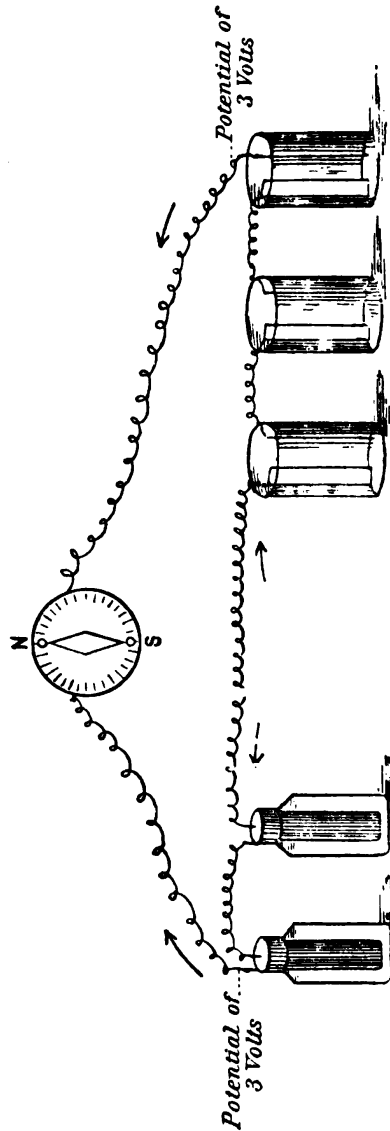

FIG. 28.—MEASUREMENT OF E. M. F. BY OPPOSITION.

amount of this resistance makes no difference ; it need not be known. All that is necessary is that precisely the same resistance should be used in the two cases, and the higher the resistance is, the less attention we need pay to the



internal resistances of the cells. Suppose we have a resistance of about 500 ohms, and that our cells give us a current of 20 m.a., and the Daniell a current of 2 m.a. ; then

$$2 : 20 :: 1 : x = 10 \text{ volts.}$$

Further, if we have a means of throwing in a resistance of exactly 1,000 ohms, including the resistance of the galvanometer, and the latter be graduated in milliampères, then we convert our galvanometer into a voltmeter, reading volts for milliampères ; for by Ohm's law 1 volt in a circuit of 1,000 ohms yields a current of 1 milliampère, and 10 volts 10 milliampères, and so on. The galvanometers of Dr. Edelmann can be purchased with this arrangement—for medical men probably the most convenient. E. M. F. may be measured, when no current is flowing, by an electrometer, an instrument we have already mentioned in connection with the electroscope. There are also voltmeters of various kinds ; they are not of sufficient importance to us to warrant a description here. A rough estimate of the E. M. F. of two or three cells at a time can be made by connecting them in series with a galvanometer and with a sufficient number of Daniells in the same circuit, but with their poles opposed to so balance the E. M. F. as to produce no deflection of the galvanometer needle. In the figure (Fig. 28), two Leclanchés are seen to be opposed by three Daniells. In like manner ten Leclanchés could be balanced by fifteen Daniells.

### RESISTANCE

The resistance, we have seen, is that which opposes the flow of electricity, and the unit of resistance is the ohm. The resistance in any galvanic circuit is also best divided into that which is present inside the cell, such as that offered by the dilute sulphuric acid of the simple cell, the *internal resistance* (designated by  $r$ ), and that which is present outside the cell in the conducting path, joining the two poles of the cell—the copper-wire electrodes and the

patient. It has been found that the resistance presented by a conductor is governed by certain laws ; for instance, it varies :

1. Directly with the length of the conductor.
2. Inversely with the area of the cross section.
3. Directly with the nature of the material of which the conductor is made (*specific resistance*).
4. With the temperature, etc.

Expressed in symbols,

$$R = \rho \frac{l}{s} (1 + at),$$

where R is the resistance,

$\rho$  ,, specific resistance,

$l$  ,, length,

$s$  ,, cross sectional area,

$a$  is a correction for temperature.

If the resistance of a certain conductor 1 yard long be equal to 1 ohm, then a 10 yards' length of the same conductor would have a resistance of 10 ohms. Again, if a conductor 1 inch in thickness and of a certain length present a resistance of 1 ohm, then a similar conductor 2 inches in thickness would only present a resistance of  $\frac{1}{4}$  ohm, because the area of its cross section would be four times as great. The water analogy still holds. The longer the pipe is through which the water has to flow, the greater difficulty it will have in passing through it, the greater will be the resistance it will encounter. Again, the larger the conducting-pipe, the more easily it will flow through it, and *vice versa*.

Substances vary enormously as to their specific resistances.\* It will be seen by referring to the table of relative conductivity that the metals are the best conductors,

\* The specific resistance depends upon the inherent qualities of the substance ; a piece of silver wire and of copper wire of exactly the same length and cross section present different resistances. The specific resistance is the resistance of a cube of 1 centimetre diameter of the substance in question between opposite sides.

## 60 A MANUAL OF PRACTICAL MEDICAL ELECTRICITY

silver, copper, and gold ranking highest. A great deal depends also upon the purity of the metal, any impurity much increasing the resistance. The molecular condition of a substance has a very great deal to do with its conductivity. Powdered copper and aluminium practically do not, except under certain conditions, conduct at all.\* All liquids offer considerable resistance. They can be divided into three classes :

1. Those which are decomposed in conducting a current. These are termed electrolytes, and the process one of electrolysis.

2. Those which are not decomposed by a current, *e.g.*, mercury.

3. Those which scarcely conduct at all, *e.g.*, oils, turpentine.

The first division is the only one we are concerned with, for the body, consisting of various tissues closely applied to one another and bathed in a saline medium, must be regarded as an electrolyte. It is useful to have some idea of the relative resistances of the liquids of the body and of others in common use in batteries, and the following table, which is constructed from a series of observations made by Kohlrausch's method, but which does not lay claim to any great accuracy, will give this. It will be noticed that urine has a low resistance. I have not attempted to measure the resistance of living blood in the vessels (see Electro-diagnosis). The observations were all made at 60° Fahrenheit.

\* Branly discovered that if a tube filled with powdered aluminium be put in the circuit of a cell with a galvanometer, no current at all will pass ; if, however, a spark from an induction coil be passed in the vicinity, a current will pass, as evidenced by a large galvanometric deflection ; this current will continue to pass until the tube be slightly shaken, when the molecules will again become disarranged and the powder a non-conductor. Compare the magnetization of a piece of soft iron. Such a tube is called a 'coherer,' and it plays a most important part in wireless telegraphy. The author exhibited such tubes in 1892 to the meeting of the British Association.

## RESISTANCE

61

<i>Character of Fluid.</i>	<i>Observed Resistance in Ohms.</i>	<i>Specific Resistance in Ohms.</i>
Milk (cow) - - -	1,025	174'2
+ 50 per cent. water	1,860	316'2
+ 75 per cent. water - -	3,250	552'5
Blood, coagulated - - -	4,000	680
Blood serum - - -	575	97'75
Dropsical fluid from cardiac ascites	475	80'75
Urine - - -	250 (varies)	42'50
Zinc sulphate, saturated	125	21'25
semi-saturated - - -	125	21'25
Copper sulphate, saturated	115	19'55
semi-saturated - - -	160	27'20
+ 75 per cent. water - -	290	49'3
Bichromate solution - - -	12	2'04
Nitric acid, strong - - -	10	1'7
+ 50 per cent. water - -	8	1'3
Sulphuric acid, strong - -	45	7'65
+ 50 per cent. water - -	15	2'55
Liq. potassæ - - -	30	5'1
+ 50 per cent. water - -	60	10'2
+ 75 per cent. water - -	100	17
Sodium chloride, saturated	25	4'25
semi-saturated - - -	40	6'8
+ 75 per cent. water - -	65	11

## Resistance of the Body.

The main resistance the current has to encounter in passing through the body is that of the skin, which when dry is a good insulator, and when moist a poor conductor ; hence the current-strength with a fixed E. M. F. (a certain number of cells kept in good order) will depend largely upon the condition of the skin. When this has by thorough moistening with warm salt solution been made as conducting as possible, the resistance of the body in health will be found to vary according to the size and position of the electrodes and the length of the part electrolyzed (distance between the electrodes) from about 500 ohms to 5,000 ohms. This brings us to the importance of using standard-sized electrodes, and of varying their sizes according to circumstances ; for as the principal resistance

is to be found in the skin, and as this resistance, *cæteris paribus*, must vary inversely with the area of the cross section through which the current can pass, we can increase or diminish it just as we please, and the current-strength in an inverse ratio, by altering the sizes of our electrodes. In any comparison of relative resistances the same sized electrodes must be used. Another important point is that the skin resistance rapidly diminishes for a time as the current continues to flow, and hence with the same number of cells the galvanometer will exhibit for some little time an increasing deflection ; this is the opposite to what occurs in an ordinary electrolyte, in which the initial current is the strongest, and in which from polarization the current will quickly fall off as it flows. That polarization occurs also in passing a current through the body can be proved, but its antagonizing influence is for a time more than counterbalanced by the effect the current has of dilating the bloodvessels, stimulating the sweat-glands, and generally congesting the part, for the more liquid the tissues contain, the better conductors they are. Occasional reversals assist in lowering the resistance, both by increasing the physiological effects and by nullifying, *pro tempore*, the polarization.

Let the following experiment be tried. Thoroughly soak the skin, apply the electrodes firmly, and turn on a current from five to ten cells. It is quite probable that no galvanometric deflection will be observable at first, though in a few minutes' time there may be one of 5 milliampères ; if the current be now reversed, a greater deflection in the opposite direction will be observed.

Resistance in a circuit is also much affected by the condition of the surface contact, and will be very much increased if this be loose and imperfect ; hence the importance of keeping the electrodes uniformly pressed upon the skin.

The resistance of the body seems also to diminish as the E. M. F. of the current is increased (see Electro-diagnosis).

Temperature affects resistance ; heat raises the resist-

ance of the metals and diminishes that of electrolytes ; it is probable that the resistance of a patient in a state of pyrexia, other conditions being equal, would be less than it would in health.

The resistance of selenium, sulphur, tellurium, etc., varies with the amount of light, that of some cells I have constructed, after Mr. Bidwell's method, varying from 100,000 ohms in subdued daylight to about 30,000 ohms in the light of magnesium wire.

### How is Resistance to be measured?

If we know the E. M. F. and the current-strength, then by Ohm's law

$$R = \frac{E}{C}$$

This is the total resistance, and by deducting the external we obtain the internal. Suppose we wish to know the internal resistance of two Leclanché cells in series, let us put them in circuit with a galvanometer, whose resistance is, say, 2 ohms, and use large copper connecting-wires so as to disregard their resistance. Then, if a current, say, of 500 m.a. be obtained, the sum will be :

$$\frac{1.5 + 1.5 \text{ volts}}{500 \text{ m.a.}} = \text{total R. in ohms} = \frac{3 \text{ volts}}{.5 \text{ ampère}} = 6 \text{ ohms.}$$

This, then, will be the total resistance, and 2 ohms for the galvanometer being deducted, 4 ohms for the resistance of the two cells will be left.

If the E. M. F. be not known, a set of resistance coils (rheostat) can be used. Connect up the cells to a galvanometer divided into milliampères, whose resistance is known, and obtain a current, say, of 300 m.a. Now introduce known resistances into the circuit until the current has fallen to 150 m.a. Then, since the current has been halved, the resistance must have been doubled, and hence the second external resistance that you have introduced must be equal to the first resistance, *i.e.*, that of the

## 64 A MANUAL OF PRACTICAL MEDICAL ELECTRICITY

galvanometer and of the cell, and by deducting the resistance of the former you obtain the internal resistance of the cell. The connecting-wires must be thick and stout if their resistance is to be disregarded.

The measurement of a large external resistance, such as that of a resistance coil or of the body, may be made simply by Ohm's law, when the E. M. F. and current-strength are known, the internal resistance of the cells being negligible ; send the current of ten Leclanché cells connected in series through any part of the body, having a milliampère meter in circuit, using standard-sized electrodes, and having the skin thoroughly moistened. Take galvanometric readings at definite periods ; these would give you by calculation the initial and subsequent resistances. Suppose a deflection of 5 m.a. at some period, then the sum would be :

$$\frac{E \text{ in volts}}{C \text{ in ampères}} = R \text{ in ohms.}$$

$$\frac{1.5 \times 10}{0.005} = \frac{15}{0.005} = 3,000 \text{ ohms.}$$

And deducting, say, 200 ohms for the resistance of the galvanometer, you would have 2,800 ohms as the resistance of the tissues at that period. This is the simplest method, and, to those accustomed to use a milliampère meter, a calculation which is made unconsciously. Another method is to pass the current from a certain number of cells with the same precautions as before through the body, obtain a certain galvanometric deviation, and then, having withdrawn the body, to interpose in the circuit in its stead sufficient known resistance by means of a rheostat, or set of resistance coils, to produce exactly the same galvanometric deviation ; then the known resistances you have interposed must be equal to the unknown resistance of the part of the body you have tested. The most accurate means of measuring resistances is with a Wheatstone's bridge and a set of standard resistance coils, and in the case of an electrolyte, such as the body, the

alternating current and a telephone. The latter is Kohlrausch's method (Fig. 29). Polarization is thus obviated; the direction of the current is reversed too rapidly to allow of any sensible electrolysis. It is not believed that accurate measurements of the resistance of electrolytes can be made by the continuous current.

Rheostats, or instruments for interposing resistance, are of various kinds. A convenient form will be mentioned further on.

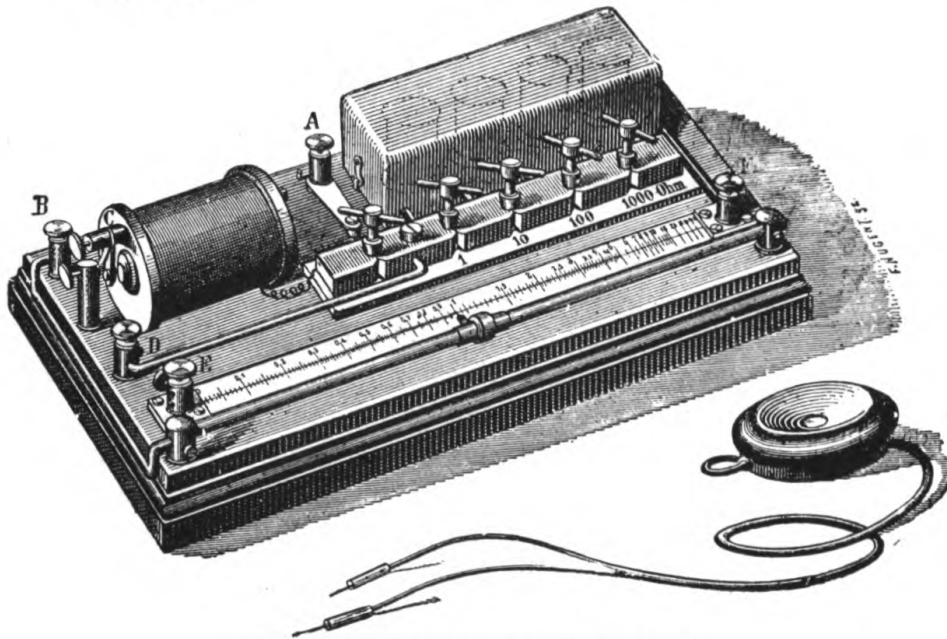

FIG. 29.—KOHLEAUSCH'S BRIDGE.

To sum up our remarks upon resistance in regard to galvanization: The resistance of the body depends mainly upon:

1. The condition (moist or dry) and thickness, presence of hair follicles and sweat-glands, of the skin.
2. The size of the electrodes.
3. Firmness of surface contact.
4. Length of application.
5. Distance apart of electrodes.\*
6. Temperature of the skin.

\* This consideration is practically nullified by the overwhelming influence of the first two.



## CHAPTER VI

### CURRENT-STRENGTH

THIS represents the quantity of electricity which flows along a given section of the circuit in a unit of time, and the medical unit of current-strength we term the milli-ampère.

Let us return to the water analogy. The difference of level or of head in two connected cisterns corresponds to difference of potential or E. M. F. ; the size of the stream along the connecting-pipe to the current-strength. If the cisterns be connected by a large and short pipe (thick and short copper wire), there will be but little friction (resistance), and the flow will be large. If in using the same pipe there be a great difference of level, the flow will be still larger. The flow of water, then, depends upon the difference of level of the two cisterns and the size and length of the pipe ; just so with electricity, the current-strength depends upon the difference of potential and the size, length, etc., of the connecting-wire.

By Ohm's law we see that the two factors we have to consider are the E. M. F. and the total resistance.

$$\frac{E}{R} = \text{current-strength ;}$$

so that to increase the current-strength we must either increase E or decrease R.

In therapeutic galvanization the limit of diminishing R by moistening the skin, etc., is soon reached, and any further increase in the current-strength must be brought about by augmenting the E. M. F. by adding on more cells

in series. But by doing this we also increase the resistance, for each cell added adds also its internal resistance, and where the external resistance is small, this almost counterbalances the advantage to be gained by the addition of its E. M. F. ; but where the external resistance is comparatively speaking very great, as obtains in the ordinary medical employment of the galvanic current, the additional internal resistance brought into play by adding on each successive cell may be disregarded.

An example will illustrate this. Take a low external resistance, say of 2 ohms, and pass the current of one Daniell cell with an internal resistance of 5 ohms through it ; our current will now be :

$$\frac{1 \text{ volt}}{R+r} = \frac{1}{2+5} = \frac{1}{7} \text{ ampère} = 143 \text{ m.a.}$$

Now add on two more cells in series, thus increasing both the E. M. F. and internal resistance three times ; our current now will be :

$$\frac{1 \text{ volt} \times 3}{R+r \times 3} = \frac{3}{2+15} = \frac{3}{17} = 176 \text{ m.a.}$$

Now try ten similar cells in series ; then

$$\frac{1 \text{ volt} \times 10}{R+r \times 10} = \frac{10}{2+50} = \frac{10}{52} = \frac{5}{26} = 192 \text{ m.a.}$$

Hence, though we obtained 143 m.a. with one cell, and 176 m.a. with three, we obtain only 192 m.a. with ten. We are therefore employing our cells very unproductively. So much for the case of a low external resistance ; but now try the same experiment with a high external resistance of 1,000 ohms. In the first case we have :

$$\frac{1 \text{ volt}}{1,000 + 5 \text{ ohms}} = \frac{1}{1,005} = \text{a little less than } 1 \text{ m.a. ;}$$

with three cells we have :

$$\frac{1 \times 3 \text{ volts}}{1,000 + 5 \times 3 \text{ ohms}} = \frac{3}{1,015} = 2.9 \text{ m.a. ;}$$

with ten cells :

$$\frac{1 \times 10 \text{ volts}}{1,000 + 50 \text{ ohms}} = \frac{10}{1,050} = 9.5 \text{ m.a.}$$

Hence, by increasing our cells by ten, we have raised our current-strength from 1 m.a. to  $9\frac{1}{2}$  m.a., or almost in the same ratio.

This brings us to what is termed the *best arrangement of cells* in a battery.

### I.—Galvanization.

It is evident from the examples we have just worked out that in the ordinary applications of galvanism to the body, where the external resistance is always high, we must have a number of cells connected together in a manner that will most increase their E. M. F. (power of overcoming resistance)—*i.e.*, in series (Fig. 26)—but that where the external resistance is low, as in cautery work, there is but little to be gained by adding on more cells arranged in this manner.

### II.—Cautery Work.

How, then, can cells be best arranged for giving the largest current through a low resistance? As there is no advantage to be gained by increasing the E. M. F. so long as this also increases in a similar ratio the internal resistance, we must endeavour to increase our current by attention to the other factor, viz., the resistance, for  $\frac{E}{R+r} = C$ ; and as our external resistance is low, it is the internal resistance to which we must attend. Upon what does this depend, and how can it be diminished?

The factors to be considered are :

1. The conducting nature of the fluid or fluids, and presence or absence of a diaphragm through which the current has to travel inside the cell (see p. 60). Thus a bichromate or a Grove's cell has very much less internal resistance than a Daniell.

2. Distance of the plates from each other ; the nearer

they are, the less fluid the current has to go through, and the less the resistance.

3. Size of the plates immersed in the fluid ; the greater the area the less the resistance.

For our present purpose, then, we choose cells which from their nature have a low internal resistance, such as the bichromate and the Grove, and we make them as large as we conveniently can to increase the area of their plates, but accumulators are to be preferred. Further, we

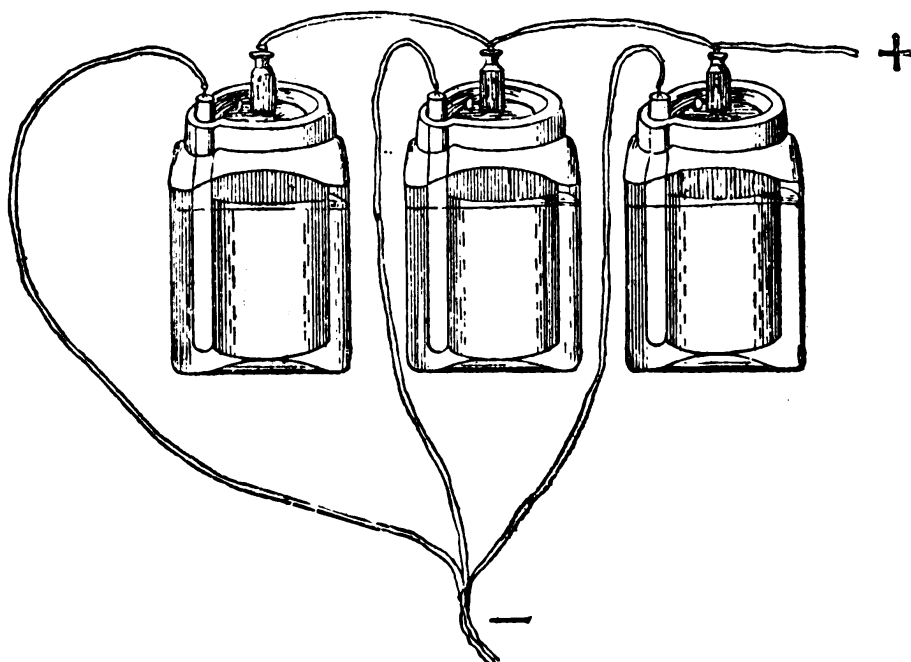

FIG. 30.—THREE CELLS IN PARALLEL.

connect our cells in what is termed *parallel* arrangement ; instead of connecting copper to zinc, we join all the copper plates together to form one + electrode, and all the zinc plates together to form the - electrode (see Figs. 30 and 31). By this means we form, as it were, one large cell with several copper and zinc plates, and as, other things being equal, the amount of resistance in any cell depends upon the area of the cross section of the plates immersed, so we have virtually reduced the resistance by the number of cells we have in this manner coupled. If one Daniell

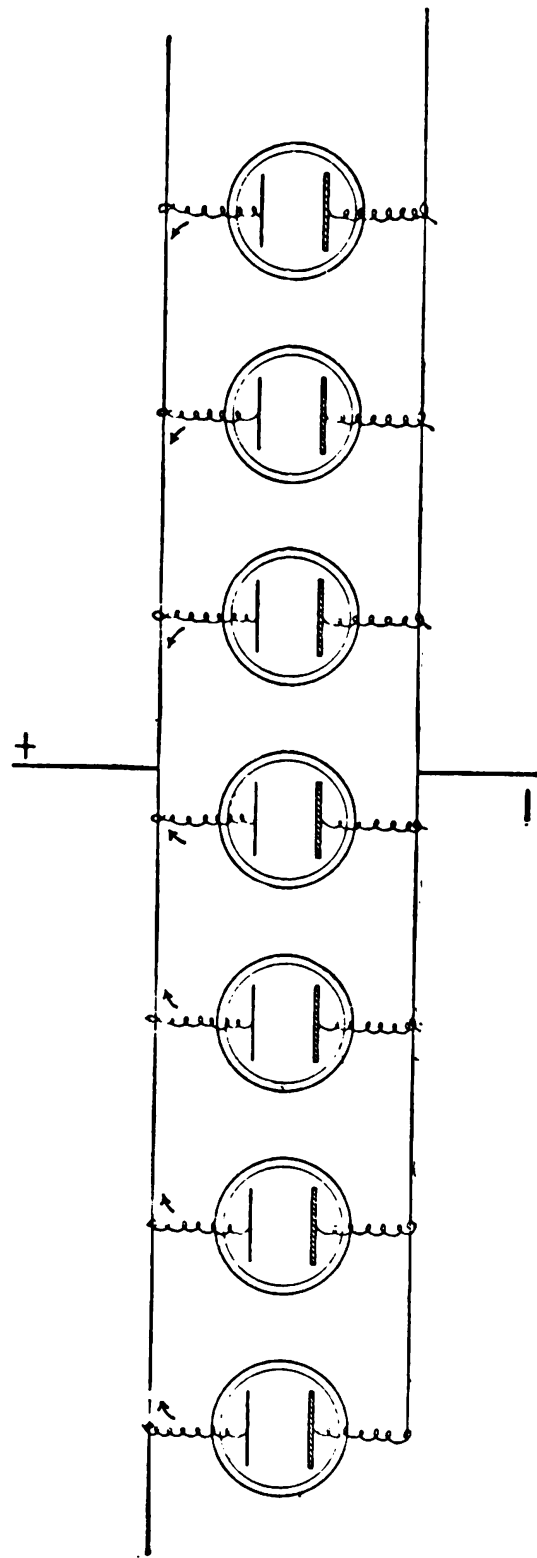

FIG. 31.—PLAN OF SEVEN CELLS IN PARALLEL.

has a resistance of 5 ohms, five Daniells so connected would have a resistance of only 1 ohm, and ten Daniells of  $\frac{1}{2}$  ohm ; but as we have practically only one cell, so we get only the E. M. F. of one cell, viz., 1 volt. As an example of the parallel arrangement, let us take one Daniell cell with an internal resistance of 5 ohms, and an external resistance of 2 ohms ; then

$$\frac{E}{R+r} = \frac{1}{2+5} = \frac{1}{7} = 143 \text{ m.a.}$$

Now add on nine cells more in parallel ; the E. M. F. will remain the same, but the internal resistance will only be one-tenth of what it was. Thus :

$$\frac{E}{R+r} = \frac{1}{2+\frac{5}{10}} = \frac{1}{2.5} = 400 \text{ m.a. ;}$$

whereas we saw that ten such cells *in series*, with the same external resistance, gave only 190 m.a. If we chose the primary cells best suited for cautery—*e.g.*, with a low internal resistance, viz., bichromate or Grove's — and coupled them in parallel, we should increase our current very much. Pass the current from one bichromate cell through an external resistance of 2 ohms,

$$\frac{E}{R+r} = C ;$$

the E. M. F. of a bichromate is about 2 volts, and the internal resistance, say, 1 ohm.

$$\frac{2 \text{ volts}}{2+1 \text{ ohms}} = C = \frac{2}{3} = 666 \text{ m.a.}$$

Now couple ten *in parallel*, then

$$\frac{2 \text{ volts}}{2+\frac{1}{10} \text{ ohms}} = C = 952 \text{ m.a.}$$

As, however, in most cases galvano-cauterics and short platinum wires have only a resistance of about 0.05 to 0.1 ohm, we should have

$$\frac{2}{0.05+0.1} = \frac{2}{0.15} = \text{more than 13 ampères, or 13,333 m.a.}$$

or sufficient to raise most varieties to a white heat. Accumulators are, however, superior to any form of primary cell for cauterizing work.

### Multiple Arc.

There is a third method of connecting cells, a mixed one, whereby some are connected in series and some in parallel. Thus, of ten cells we may couple five cells together in series, and other five also in series, and then join the positive poles of each together to form one positive electrode, and the negative poles of each together to form one negative electrode. Our sum now, supposing we were using bichromate cells, and the same external resistance of 0.05 ohm, would be as follows : the E. M. F. would be that of five cells ( $2 \times 5 = 10$  volts); the internal resistance would be that of five cells of double the size ( $1 \text{ ohm} \times 5 \div 2 = 2.5$  ohms); hence

$$\frac{E}{R+r} = C. \quad \frac{10 \text{ volts}}{0.05 + 2.5 \text{ ohms}} = \frac{10}{2.55} = 4 \text{ ampères nearly.}$$

The effect of this arrangement, it will be observed, is to double the size of the cells and to halve their number. Six cells are shown in Fig. 32.

Another mixed method would be as follows : Taking ten cells to connect each group of five in parallel, and then these two groups in series; that would be equivalent to connecting two cells, each five times as large as a single cell, in series. The E. M. F. would therefore be that of two cells, viz., 4 volts, and the internal resistance that of 1 ohm divided by five + 1 ohm divided by five. Thus :

$$\frac{E}{R+r} = C. \quad \frac{4 \text{ volts}}{0.05 + 0.2 + 0.2 \text{ ohm}} = \frac{4}{0.45} = 8.8 \text{ ampères.}$$

Six cells so connected are shown in Fig. 33.

A battery of a *given number of cells* will send the strongest current through a given external resistance when the cells are connected (in series or in parallel, or partly in series

and partly in parallel), so that the resistance of the battery equals as nearly as possible the external resistance. (This has been proved by differential calculus.) Thus, for galvanization small cells with a great internal resistance give almost as strong a current as large cells with a low internal resistance; while in cauterizing work, where the external

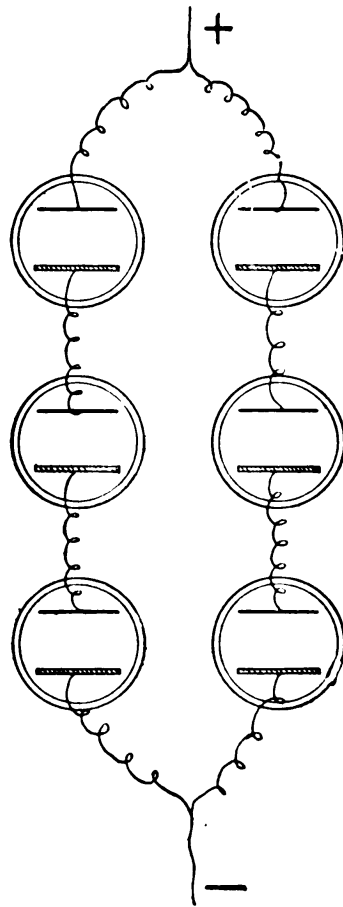

FIG. 32.—SIX CELLS IN COMPOUND CONNECTION.

resistance is very low, the internal resistance must also be made low if satisfactory heating power is to be obtained. The most economical method will, however, be to choose under all circumstances cells, other things being equal, with as low an internal resistance as possible, and therefore as large as may be convenient; for it is evident that what-



ever energy is expended in overcoming an excessive internal resistance is wasted, and that only that amount of energy which would be occupied in overcoming the lowest convenient internal resistance can be considered to be usefully employed. High internal resistance is never an advantage, though when the external resistance is also high it may not be a material disadvantage.

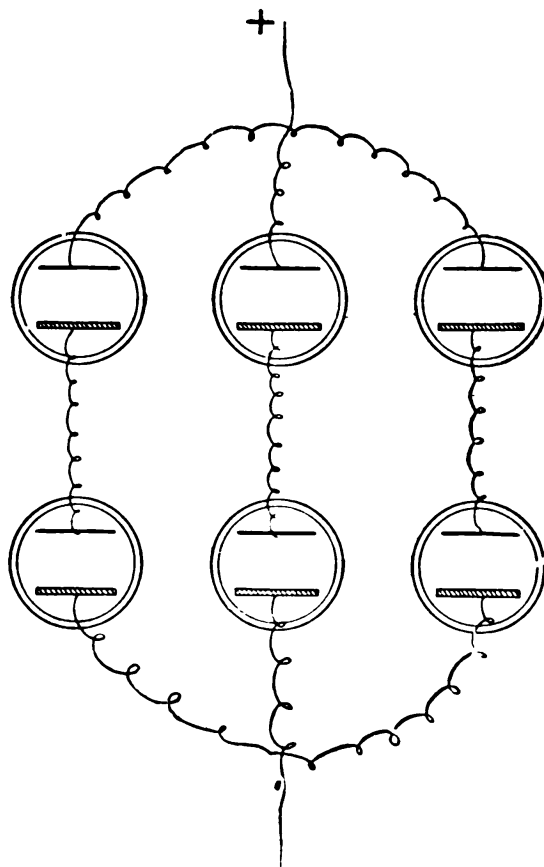

FIG. 33.—SIX CELLS IN COMPOUND CONNECTION.

Large cells have also other advantages : they are more easily attended to and cleaned, are more durable, and, containing a larger supply of electrolyte, depolarizer, and bigger plates, they give a more constant current and are not so easily exhausted. When, however, a portable battery is required, small cells are essential.

### III.—Electrolysis.

‘How should we arrange our cells for electrolyzing tumours?’ In electrolysis the resistance will vary with the position of the poles. If one pole be placed on the skin, and the other plunged into the tumour, the resistance will be much greater than it would be if both poles were passed into the tumour, because in the latter case the resistance of the skin would be eliminated. The resistance of the blood in an aneurism, when both poles are inserted, is about 8 ohms, according to Bartholow, though from my own observations in measuring the resistance of blood clot and blood serum I should imagine it to be much more; but in other electrolytic applications the resistance may go up to 200 or more ohms. The current-strength requires to be much greater than in ordinary galvanic treatment, from 20 to 100, or even 200 m.a. What, then, will be the best arrangement of cells?

- Suppose the external resistance to be 100 ohms, and the current-strength required 100 m.a.; then, since the E. M. F. is found by multiplying the resistance by the current-strength, 100 ohms  $\times$  0.1 ampère = 10 volts, which, if the internal resistance be neglected, would be the voltage required. That could be obtained from five bichromate, seven Leclanché, or ten Daniell cells, in series. Take the bichromate first, allowing 1 ohm for the internal resistance of each cell; then

$$\frac{E}{R+r} = C. \quad \frac{\text{Volts } 2 \times 5}{\text{Ohms } 100 + 1 \times 5} = \frac{10}{105} = 95 \text{ m.a.}$$

Now take the Daniell, allowing 5 ohms for each cell's internal resistance:

$$\frac{\text{Volts } 1 \times 10}{\text{Ohms } 100 + 5 \times 10} = \frac{10}{100 + 50} = \frac{10}{150} = 66 \text{ m.a.}$$

In order to obtain 100 m.a., it would be necessary to use twenty Daniells in series, thus:

$$\frac{\text{Volts } 1 \times 20}{\text{Ohms } 100 + 5 \times 20} = \frac{20}{100 + 100} = \frac{20}{200} = 100 \text{ m.a.}$$

If Leclanché cells be used, it would require from eight to ten in series if the internal resistance of each cell be put at 3 ohms, for

$$\frac{\text{Volts } 1.5 \times 10}{\text{Ohms } 100 + 3 \times 10} = \frac{15}{130} = 115 \text{ m.a.}$$

From these examples it is evident that, while ordinary Leclanché or Daniell cells connected in series, particularly if large, and if the external resistance be high, will suffice, yet that bichromate or Bunsen are much better adapted for the work. For Apostoli's treatment forty to sixty large Leclanché cells will do.

#### IV.—Lighting Purposes.

There is yet another application of electricity for which cells must be arranged, viz., for lighting the small incandescent lamps attached to the laryngoscope, cystoscope, etc. The resistance of the carbon filament in the lamps varies from about 3 to 20 ohms, and a current-strength of from  $\frac{1}{2}$  to 2 ampères is required to light them properly. As the external resistance here is low, a small electromotive force of from 4 to 12 volts will suffice, and this can be obtained by coupling a few cells in series; but as the current-strength must be comparatively so great, large cells with a low internal resistance must be used.

Try five bichromate cells in series; then, allowing 1 ohm for the internal resistance of each cell, and 5 ohms as the resistance of the lamp, we should get

$$\frac{E}{R + r} = C. \quad \frac{\text{Volts } 2 \times 5}{\text{Ohms } 5 + 1 \times 5} = \frac{10}{5 + 5} = \frac{10}{10} = 1 \text{ ampère ;}$$

and, as these cells have usually very much less resistance than 1 ohm each, a larger current would be obtained. Accumulators would be more satisfactory because of their freedom from polarization.

If Leclanché cells with an internal resistance of 2 ohms

each were used, the following, if six cells were used, would be the result :

$$\frac{\text{Volts } 1.5 \times 6}{\text{Ohms } 5 + 2 \times 6} = \frac{9}{17} = \text{about } 0.5 \text{ ampère,}$$

which would scarcely be sufficient, nor would the current be constant enough. If more of the same cells in series, for the sake of illustration, were used, say ten :

$$\frac{\text{Volts } 1.5 \times 10}{\text{Ohms } 5 + 2 \times 10} = \frac{15}{5 + 20} = \frac{15}{25} = 0.6 \text{ ampère,}$$

so that very little would have been gained.

The best arrangement of cells for the galvano-cautery has already been considered.

Let us recapitulate briefly what has been said about the uses of the various cells, and of their arrangement for different purposes (see also 'Choice of Batteries,' p. 139).

For ordinary 'treatment by galvanism' a large number of cells (ten to forty) are required, and these must be coupled in series, and whether the cells are large or small will not make much difference in the current-strength. Leclanché cells are perhaps the best for a house installation.

For 'electrolysis' the same arrangement of cells will do, but they should be larger.

For 'electrical lighting,' cells which combine a high E. M. F. with a low internal resistance (accumulators, bichromate or Bunsen), and of large size, must be used, and of these from three to six, or more, connected in series.

For 'galvano-cautery' the same cells as those used for electrical lighting, but connected in parallel or multiple arc (see also 'Secondary Batteries') are desirable.

For a 'portable' battery dry cells are to be preferred. The No. 6 Hellekens will be found very suitable for galvanism; the No. 2 for electrical lighting; but for cautery work a portable accumulator is best.

For apparatus for use with the electric light mains, see p. 122.

## CHAPTER VII

### MEASUREMENT OF CURRENT-STRENGTH

WHEN a current is passed through an electrolyte, such as acidulated water, it decomposes it into oxygen and hydrogen, the former being liberated at the anode, the latter at the kathode. If, then, the volumes of gas liberated in a certain time were measured, a correct estimate of the current-strength during that period could be made. Again, when a current encounters resistance, as it does in passing along a wire, particularly a thin wire, or one which is not a good conductor, it heats it; by adopting a suitable arrangement (such as the linear expansion of a wire) for observing the quantity of heat generated in a certain time, the current-strength can be calculated.

Oerstedt, in 1819, discovered that a magnetic needle was deflected by a current, and on this principle instruments (galvanometers) are now constructed which will measure accurately even  $\frac{1}{1000000}$  of an ampère.

Of these three direct means of measuring the current-strength, the second and third are the most suitable for our purposes.

#### The Voltametric Method.

Faraday discovered that when an electrolyte, by the passage through it of a current, was decomposed into its constituent atoms (ions), the amount of the ions liberated at an electrode in a certain time was exactly proportional to the strength of the current, and that thus a current of 1 ampère would liberate just twice the amount of ions

that a current of  $\frac{1}{2}$  ampère would do. A current of 1 ampère's strength, in passing through water acidulated with sulphuric acid, will liberate 114.6 cubic millimetres of hydrogen and 57.3 cubic millimetres of oxygen per second, *i.e.*, about 10.320 cubic centimetres of mixed gases per minute, and therefore a current-strength of 1 milliampère will liberate the one-thousandth part of that, *viz.*, 10.3 cubic millimetres per minute.

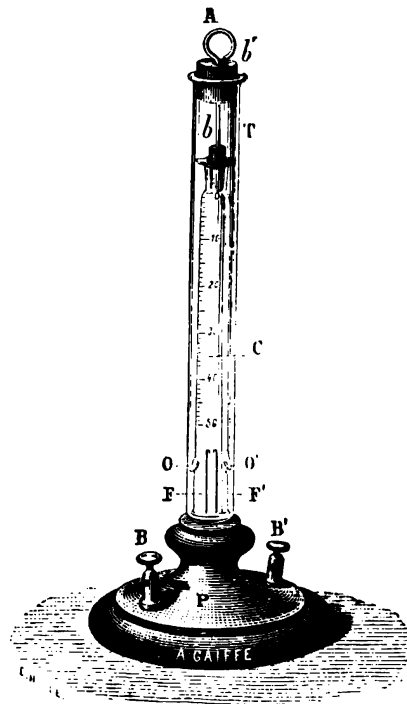

FIG. 34.—VOLTAMETER.

Gaiffe has on this principle constructed a convenient voltameter, consisting of two tubes (Fig. 34), the one within the other, and the inner one graduated in cubic millimetres, one division corresponding to 50 cubic millimetres. The inner tube is closed by a cork at the top, and has also two openings at the bottom, through which water can pass. Two platinum wires project into the inner tube at the base, and can be respectively connected with the two poles of the battery. Both tubes are filled with

acidulated water, the external one to act as a reservoir to the internal one.

On completing the circuit, the time having been noted, the current passes from one platinum wire to the other through the water, which it decomposes into oxygen and hydrogen ; these collect above the water, driving the latter out through the two apertures into the larger tube. Let the amount of gas liberated be read off on the scale at the end of a minute, and suppose two divisions be the amount, then, since each division represents 50 cubic millimetres, and a current of 1 milliampère will liberate 10.3 cubic millimetres in a minute, it is evident that our current has done ten times as much work, and has therefore been one of 10 milliampères. Another observation can be at once

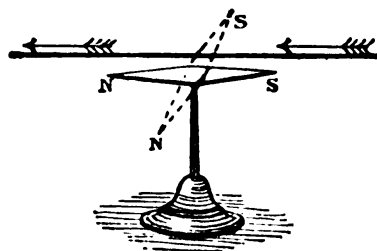

FIG. 35.—ACTION OF THE ELECTRIC CURRENT ON A MAGNETIC NEEDLE.

made by allowing the water to re-enter the inner tube by raising its cork by means of the wire attached to it. An objection to this method is that some of the gas remains dissolved in the water, or adheres to the electrodes. Further, the average and not the immediate current-strength is obtained.

### The Galvanometric Method.

When a wire carrying a current is brought near to a magnetized needle, the latter will attempt to set itself at right angles to it (see 'Magnetism,' p. 18)—Fig. 35. This can be easily verified by connecting the two poles of a cell and bringing the wire that forms the connection just over the needle of an ordinary pocket compass. Having observed the deviation of the needle, include one or two more cells in the circuit, and the deviation will be increased. It

will be noticed that the direction in which the north-seeking end of the needle is deflected depends upon the direction and position, above or below the needle, of the current. If the wire be held above the needle, and the current be travelling from south to north (Fig. 36), then the north-seeking end of the needle will be deflected to the west; while if the current be travelling from north to south, the north-seeking end of the needle will be deflected to the east. The needle, therefore, indicates the direction of the current. If the wire, however, be held below the needle, the deflections will be reversed (the lower diagrams represent the current passing beneath the needle). It follows, then, that a current passing from south to north above the needle will tend to deflect it in the same direction as a current passing from north to south below the needle, and that we have only, therefore, to bring our wire back below the needle to obtain an increased effect.

A galvanometer can thus be used to indicate—

- (a) That a current is passing.
- (b) The direction of the current.
- (c) The strength of the current.

These motions can be easily remembered by Ampère's rule :

' Suppose yourself to be swimming with the current with your face to the needle, then the north-seeking pole of the needle will be deflected towards your left hand.'

In dealing with the comparatively large current produced by one Leclanché cell on short circuit (some 300 m.a.), the deviations of the needle can be easily seen; but when we come to currents only  $\frac{1}{100}$  or  $\frac{1}{50}$  as strong, as in galvanization, the deflections would be so slight as to be almost valueless, and some means of increasing them must be adopted if our instrument is to be of use to us.

In galvanometers for medical practice this is usually done by increasing the number of times the current has to pass along the needle by coiling the insulated wire which carries it round the needle. Here the effect will be nearly equal to the effect produced by one coil multiplied



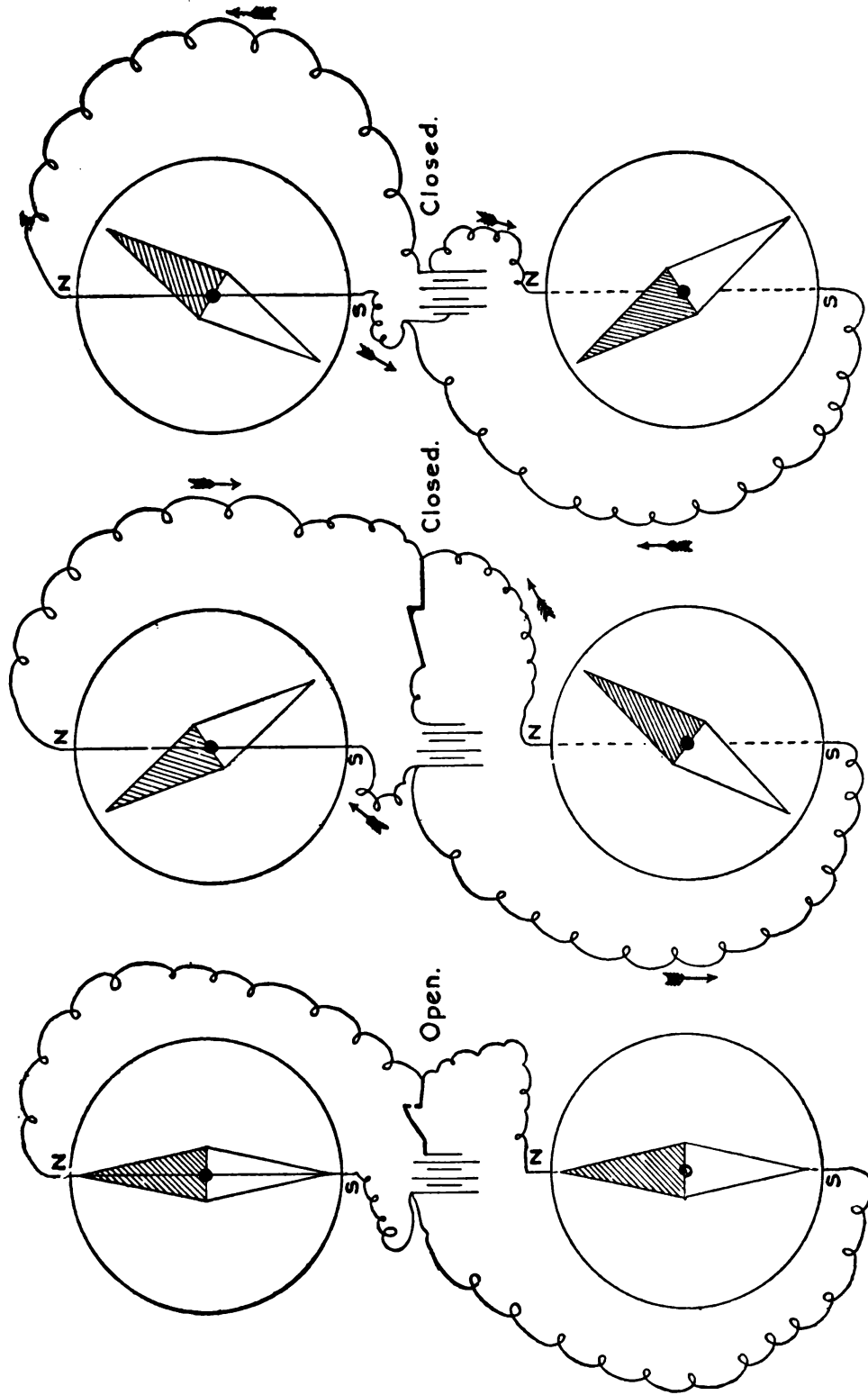

FIG. 36.—DIAGRAM OF THE ACTION OF AN ELECTRICAL CURRENT ON A MAGNETIC NEEDLE.

by the number of coils—nearly, because the position of each subsequent coil with reference to the needle cannot be in so advantageous a position as the first turn, and, moreover, the needle is not equally deflected by each equal addition of current-strength, because its poles, in being deflected, pass further and further from the influence of the coils.

Tangent and sine galvanometers are instruments so constructed that the tangent of the angle of deflection in the one case, and the sine of the angle through which the coil has to be turned in the other case, are proportional to the strength of the current.

In galvanometers for physiological purposes, a means of rendering the instrument even more sensitive must be employed, and since the position which the needle takes up in the ordinary galvanometer is the resultant of two forces—viz., the strength of the current, and the earth's magnetic force—the greatest deviation is to be obtained when the former is as strong as possible, and the latter as weak as possible; the former can, as we have shown, be increased by coiling the wire, and the latter can be diminished by using an astatic arrangement, *i.e.*, one in which two similar magnetic needles are united in such a way that the north-seeking pole of the one is placed over the south-seeking pole of the other. Were the two needles both exactly equally magnetized, the directive force of the earth's magnetism would be eliminated, and the position the needles would take up would depend upon the torsion exerted by the thread suspending them. As, however, it is difficult to bring this about, one needle is usually somewhat stronger than the other, and the difference in strength determines a position in which the needles will always come to rest after a deflection.

Both needles will tend to be deflected in the same direction if the wire be coiled round one only of them, because the effect of a current passing from north to south above one needle will be the same as one passing in the same direction below another needle, provided that the

## 84 A MANUAL OF PRACTICAL MEDICAL ELECTRICITY

poles of the needles are in reversed positions to one another.

The directive force of the earth's magnetism can also be weakened or neutralized by employing a controlling magnet, placed vertically above the needle, and fitted with an arrangement whereby it can be made to approach or recede from the needle.

In the mirror galvanometer of Lord Kelvin (Fig. 37), this controlling or compensating magnet is made use of. The needles are astatic, and as light as possible; the wire is coiled round each set of needles, and in such a way that their influence in producing a deviation is combined.



FIG. 37.—REFLECTING GALVANOMETER.

Instead of a pointer, a tiny mirror is attached by its back to one set of the needles, and from a lamp set at a suitable distance a ray of light passes through a small slit on to the mirror, and is reflected on to a scale. The magnetic needles are suspended by a fine cocoon silk fibre, and are provided with a dead-beat arrangement for bringing them to rest as quickly as possible. The controlling magnet above can be turned horizontally, as well as raised or lowered, and can therefore be used either to bring the mirror to rest in any desired position, or to so counter-balance the earth's directive magnetism as to render the needles quite astatic. The instrument is mounted upon

three screw feet, and must be made quite level before an observation is taken.

I have mentioned that the angle of deflection of a galvanometric needle is not constantly proportional to the strength of the current; a simple experiment will show this. Pass the current from one Daniell cell with a resistance of 1,000 ohms in the circuit through a simple galvanometer; we obtain a certain deflection which is equal to 1 milliampère. Now add on another Daniell cell,

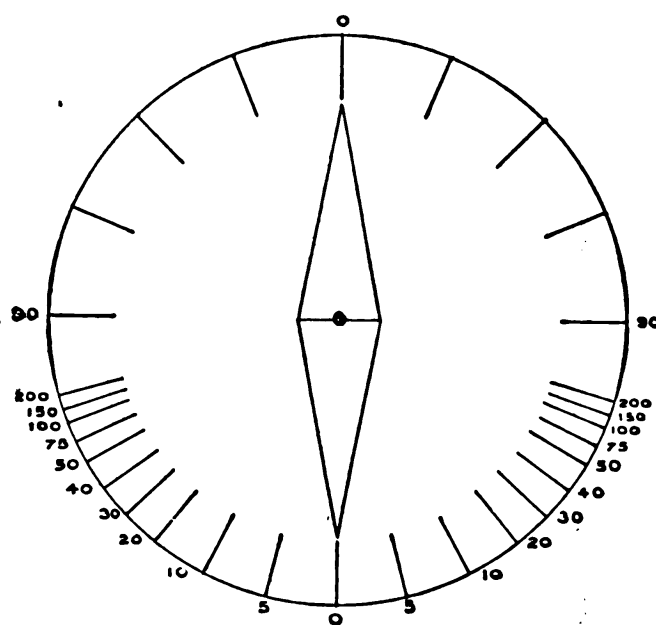

FIG. 38.—DIAGRAM OF A GALVANOMETER, DIVIDED IN ITS UPPER HALF INTO DEGREES, AND IN ITS LOWER HALF INTO MILLIAMPÈRES.

which will yield us practically a current of 2 milliampères, for, disregarding the resistance of the galvanometer and of the cells in presence of so large an external resistance, we have respectively

$$\frac{1 \text{ volt}}{1,000 \text{ ohms}} = 1 \text{ m.a.}, \text{ and } \frac{1 \text{ volt} \times 2}{1,000 \text{ ohms}} = 2 \text{ m.a.}$$

The amount of deflection of the needle, however, which is produced by the addition of the second cell will not be so

great as the first, and the addition of every subsequent cell will yield a decreasing series of deflections (Fig. 38).

If the resistance of the galvanometer in the last experiment be considerable, the external resistance of 1,000 ohms should be diminished by the amount of the resistance of the galvanometer, so as to make the total external resistance one of 1,000 ohms.

In order, then, that the deflections of the needle may be made a correct index of the current-strength, it becomes necessary to calibrate them by comparison with a standard

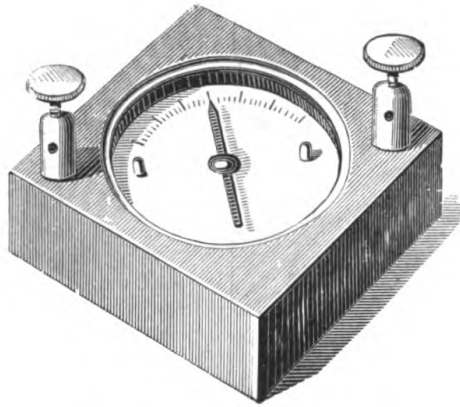

FIG. 39.—GALVANOSCOPE.

instrument, or by a known strength of current, and this should give readings in milliampères.

An instrument not so calibrated is termed a galvanoscope; it merely serves to indicate that a current is passing, and its deviation gives no real index of the current-strength (Fig. 39).

A good medical galvanometer should be graduated in milliampères, and should give readings by means of shunts from  $\frac{1}{2}$  milliampère to 300 milliampères. A 'shunt' is a sort of short cut, along which we can at will allow a certain proportion of the current to pass without influencing the galvanometer.

Suppose we have (Fig. 40) a current of 10 milliampères passing along a wire, and at a point, A, we connect to it

another wire of the same material, size, and length, joining them again together at B; then, since the resistance of each wire is equal, and the current finds two paths of equal conductivity open to it, it will divide into two equal parts,

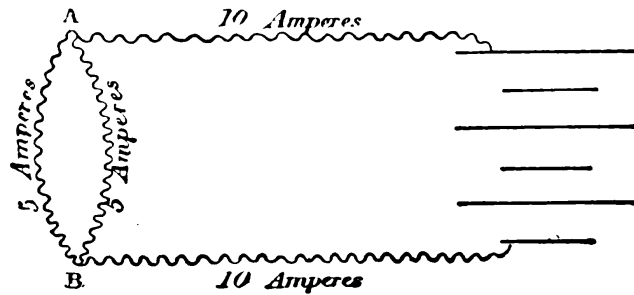

FIG. 40.—DIVIDED CIRCUIT.

and 5 m.a. will pass along one and 5 m.a. along the other.

If in place of two such wires we had ten, we should find that the current would also divide into ten parts, and that 1 m.a. would flow along each wire.

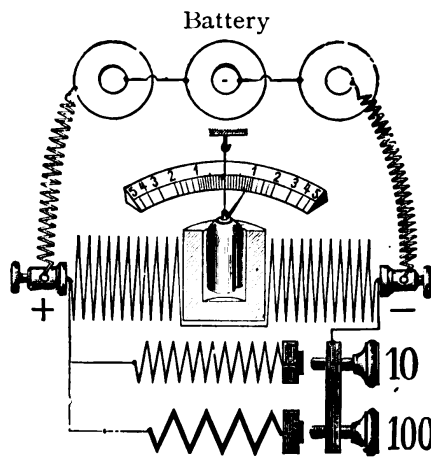

FIG. 41.—GALVANOMETER SHUNTS.

The relative strength of current in each branch wire will be proportional to its conductivity, *i.e.*, inversely proportional to its resistance.

Further, the total resistance of the circuit will be

lowered according to the number of branches, because, as already mentioned, the resistance of a conductor varies with its sectional area.

If in a branched circuit of two wires one, by reason of its greater size and shorter length, has only  $\frac{1}{10}$  of the resistance of the other, then  $\frac{10}{11}$  of the current will pass through it, and only  $\frac{1}{11}$  through the other.

A shunt (Fig. 41) in a galvanometer is, then, a divided circuit along the short branch of which we can, if we choose, allow a certain proportion, usually  $\frac{9}{10}$ , of the current to pass without its influencing the magnet, with

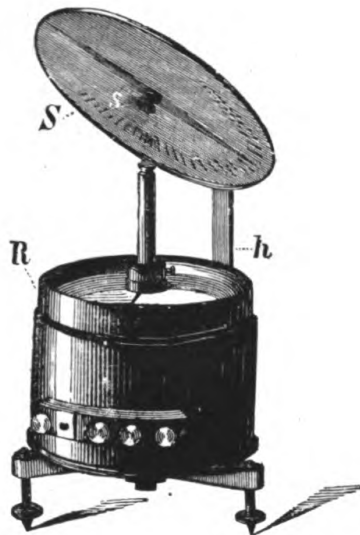

FIG. 42.—EDELMAUN'S GALVANOMETER.

the result that, when the shunt is closed, it will require ten times as great a current as it took before the shunt was screwed home to produce an equal amount of deflection, so that the numbers on the dial have to be multiplied by ten to obtain a correct reading.

In Dr. Edelmann's universal galvanometer (Fig. 42), readings can be taken by means of shunts from  $\frac{1}{10}$  milli-ampère to 500 milliampères; the needle is in the form of a horseshoe, and it carries an aluminium pointer. It is suspended by a cocoon silk fibre, which can be lowered when

the instrument is not being used, so as to allow the needle to rest. Round the needle is a copper damper to prevent useless oscillations and to render it dead-beat. The resistance of the galvanometer, both with and without the shunts, is stamped on the face, and an extra resistance is usually added whereby the total resistance may at will be made to reach 1,000 ohms, an arrangement which practically converts the galvanometer into a voltmeter. Another excellent galvanometer is that of Mons. d'Arsonval (made

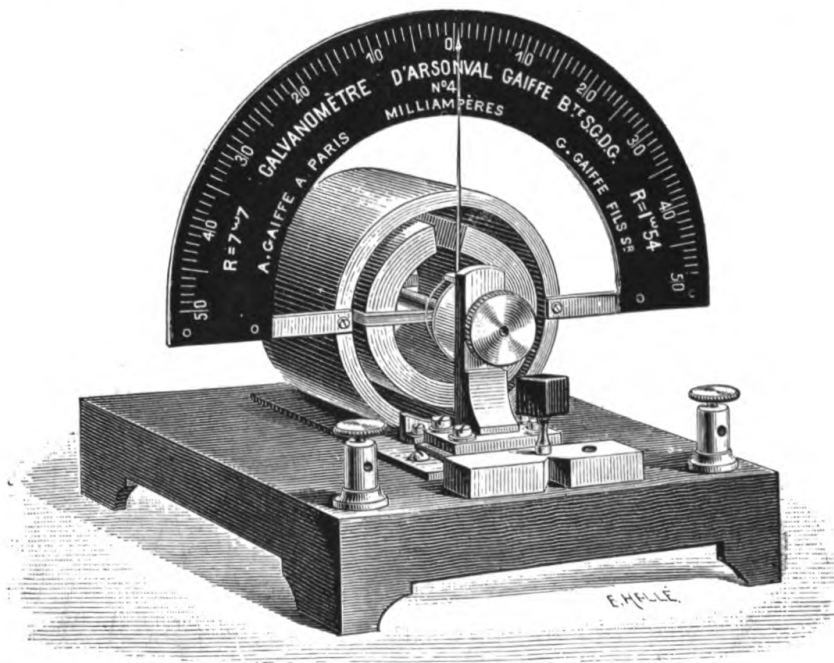

FIG. 43.—D'ARSONVAL'S GALVANOMETER WITH VERTICAL SCALE.

by Gaiffe). In this instrument the magnet is fixed, and the wire carrying the current is movable. The magnets consist of two split cylinders or horseshoes of steel of nearly equal mass, and placed one within the other; between them is a movable frame, whose axis of rotation is a wire that is fixed by two supports at either end of the cylinders; a few turns of wire are taken round the frame along which the current passes. For medical purposes a vertical aluminium pointer marks off on a large scale above the deviations of the frame; for physiological purposes the



frame bears a small mirror to reflect a ray of light as in the Kelvin instrument (Fig. 43). The instrument is sensitive, fairly dead-beat, and not influenced by either the magnetism of the earth or by the proximity of other magnets or masses of iron. For medical men Edelmann's or Gaiffe's galvanometers, or rather milliampère meters, are probably the best. The portable form of the d'Arsonval can be bought for about £2 10s. The full-size Gaiffe costs about £6. Fig. 44 represents a sensitive and portable d'Arsonval galvanometer sold by Schall. Thanks chiefly to Dr. de Watteville, the milliampère meter is now

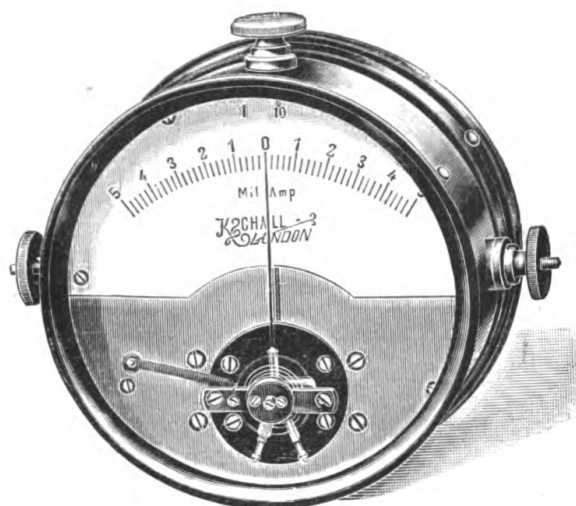

FIG. 44.—D'ARSONVAL GALVANOMETER.

a necessity for all those who wish to use electricity rationally and scientifically. Yet electricity is still expected by some to do good when applied haphazard, without any other idea of the strength than is afforded by the patient's feelings and the number of cells in circuit, and for indefinite periods, by unskilled persons, and when it does not do good it is discarded as useless. We might as well expect indefinite and varying doses of drugs at odd times to do good. When we consider the rapid fall in electromotive force, and the occurrence of polarization even in good batteries, and their rapid exhaustion, without allowing for

short-circuiting, want of proper contacts, breaks in the rheophores, etc., and also the ever-varying resistance of the human body, it becomes absolutely imperative that we should always use a means of scientifically measuring the current that is flowing, if one be flowing at all. In no other manner can we do any sort of justice either to the patient, to ourselves, or to the power we are using.

### Hot-Wire Instruments.

For the measurement of alternating or high-frequency currents the magnetic instrument would be useless, but the heating effect of the current can be adopted; such instruments are known as 'hot-wire' milliampère meters. By the heating and expansion of a fine platinum wire a pointer is caused to rotate over a scale. The instrument can be calibrated to read in milliampères (see p. 28).

## CHAPTER VIII

### ACCESSORIES

BESIDES a battery and a galvanometer, we require a collector, current reverser, rheostat, rheophores, and electrodes.

#### Collectors.

A collector enables us to add on cells without breaking the circuit; the three chief forms are the 'plug,' the 'sledge,' and the 'dial' collectors.

In the simplest form the 'plug,' a bifurcated rheophore, is used for one pole, while a single rheophore is screwed fast to the other pole.

From each of the wires connecting cell with cell a branch is carried to one of a series of small metal tubes inserted in the side of the battery-box; when the battery is used the end A of the double rheophore is inserted (it should be made to fit) into the first tube; the end B can then be inserted into the second tube, while the end A is withdrawn from the first tube and inserted into the third tube. We have now three cells in circuit, and could go on adding more and more without at any time breaking the current. This is the cheapest and simplest form of collector, but it is also the slowest. In Fig. 45 it is shown to be collecting cells in pairs, but one by one would be preferable.

The 'sledge' collector is used in Dr. Stoehrer's battery. The sledge, to which both the rheophores are attached, and which carries on it a current reverser, slides along above the cells, making contact by springs on its under surface with conductors to which the wires from the cells

are led, and the springs are long enough to reach from conductor to conductor, so as to avoid breaking the current as the 'sledge' is moved.

Of the ordinary or 'dial' collector there are two forms—the single-handled and the double-handled.

On the dial (Fig. 46) are placed a number of studs in a circular form, and to the under surface of each stud is fastened a branch wire from, say, the negative pole of each cell respectively.

To the central pin, upon which the handle turns, the

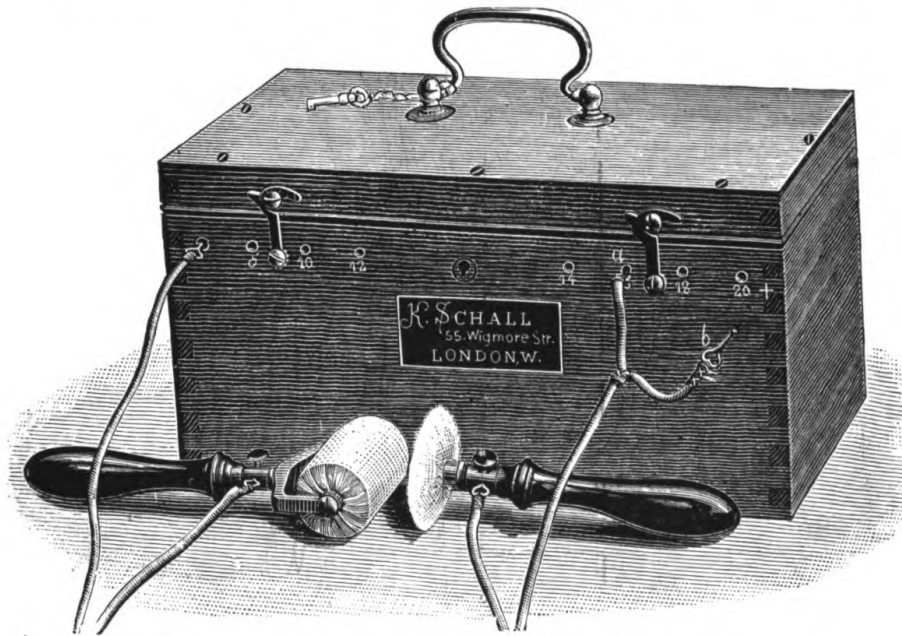

FIG. 45.—BATTERY WITH PLUG COLLECTOR.

wire to the negative electrode is attached; the other extremity of the handle rests upon and can be made to slide over the studs, which are placed in such juxtaposition that the handle must come into contact with the next one before the previous one is left.

By this arrangement it is obvious that cells can be rapidly added on or taken off without breaking contact. The disadvantage of the single-handled form is that the first set of cells must always be put in action when the battery is used, while the cells at the other extremity get

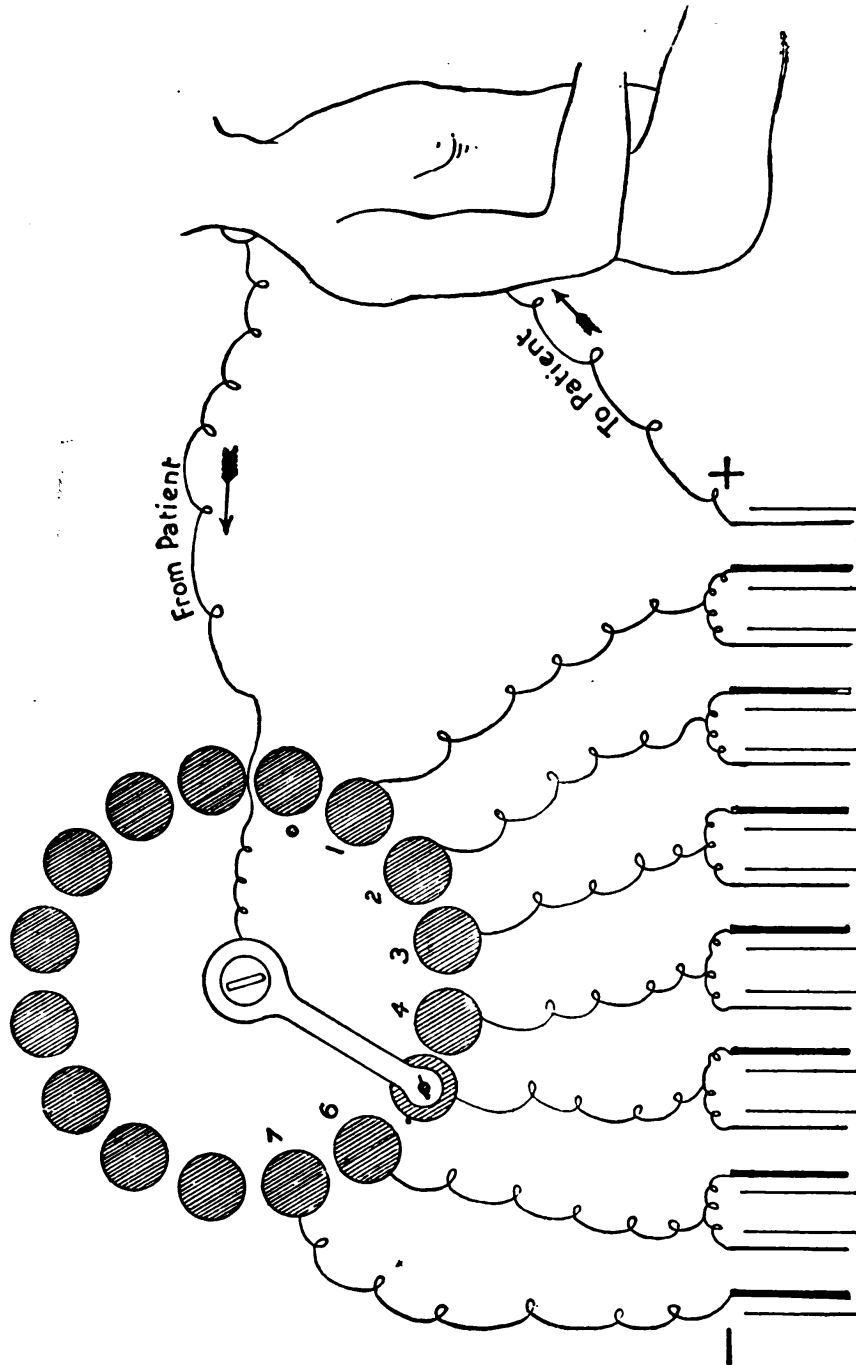

FIG. 46.—SINGLE-HANDED COLLECTOR.

perhaps scarcely any use. To remedy this, the double-handled collector (Figs. 47 and 48) has been introduced, by which the cells in circuit may be taken from any point in the battery, and any particular cell can, in fact, be at once singled out and tested. In principle it resembles the

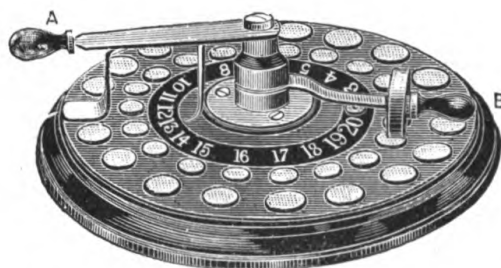

FIG. 47.—DOUBLE COLLECTOR.

single-handled dial collector, but is more complicated. The diagram (Fig. 49) exhibits the connections. The cells are connected severally to each successive stud, with which the two handles, which are insulated from each other, can

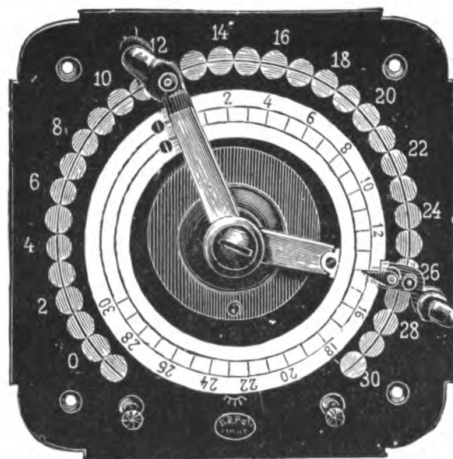

FIG. 48.—DOUBLE COLLECTOR.

be brought into contact. All that has now to be done is to connect one handle to the anode, and the other to the kathode. The number of cells in circuit is indicated by the revolving circle.

This is the best form of collector. The cells are switched

on one by one, and may be taken from any point in the battery. A 'current reverser' or commutator is simply

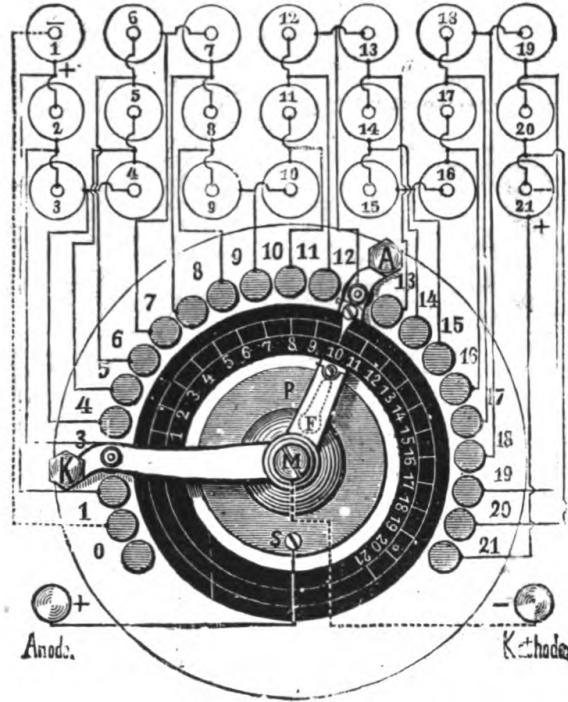

FIG. 49.—CONNECTIONS OF DOUBLE COLLECTOR.

a key for reversing the poles. The usual modern form consists of a suitable frame holding three brass plates or studs (Figs. 50 and 51), over which two brass arms can be made

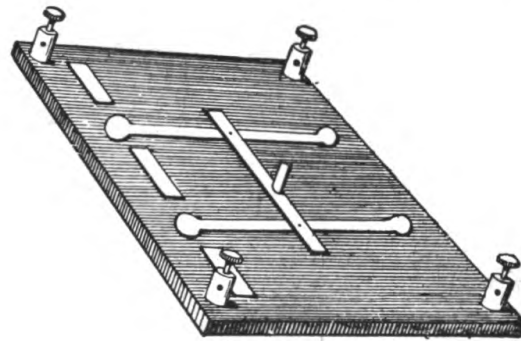

FIG. 50.—CURRENT REVERSER.

to slide, and which are fixed at such a distance from each other by a non-conductor as to allow of their making

contact' with the central stud and either W. or N. The arms are connected by the pivots on which they turn with the two terminals of the battery-box. The central stud is connected to the + pole of the cells, and W. and N. to the - pole. In the position the arms are in in the diagram, the battery-box terminals are + and - respectively ; if

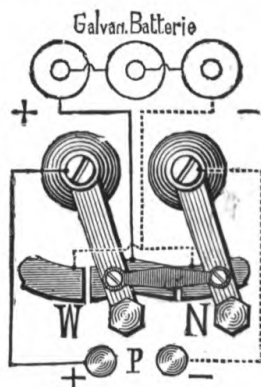

FIG. 51.—CONNECTIONS OF CURRENT REVERSER.

the arms are pushed over, the polarity of the terminals will be reversed.

### Solid Rheostats.

Of rheostats for interposing resistance there are solid and liquid forms. The solid are made of German silver wire (because it is but little affected by changes of temperature), or of graphite. The plug rheostat or resistance-box (Figs. 52 and 53) contains a number of coils of German silver wire ; each coil is wound with such an amount of insulated wire as to present a definite resistance, the two ends of the wire being connected severally to small brass pieces, which are securely fastened to an ebonite lid. These plates can be respectively connected with one another by the insertion between them of well-fitting brass plugs. When all the plugs are put in the current flows easily from brass piece to brass piece, from one end of the box to the other ; but if a plug be withdrawn, the current is compelled to travel round the coil of wire between the two brass pieces, and so to encounter the known resistance of the wire. The coils are usually arranged in a series of



increasing resistances ; thus, the first may have a resistance of 1 ohm, the second of 2, the third of 3, and so on, so that it is possible by combining them to obtain a wide

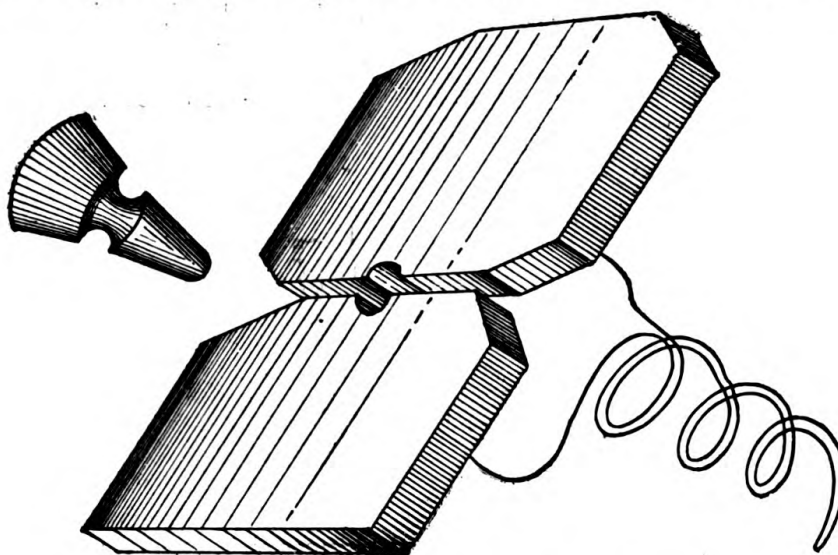

FIG. 52.—DIAGRAM OF PLUG RHEOSTAT.

range of resistance. These are expensive, but very accurate, instruments.

In another and much simpler form for use with cautory batteries, where the resistance to be introduced must be

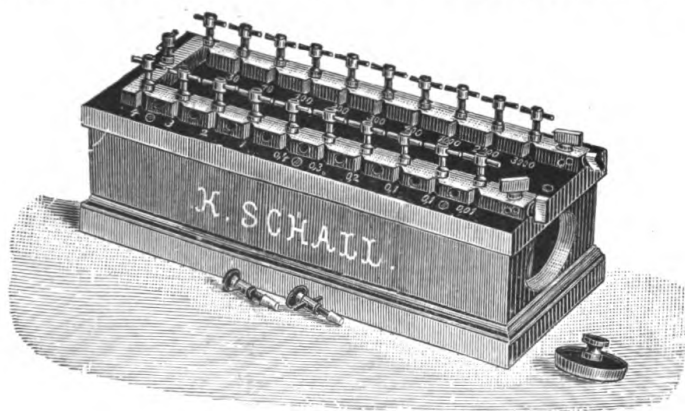

FIG. 53.—PLUG RHEOSTAT.

very low (up to 1 ohm), a single coil of uninsulated, thick German silver wire is wound, with each turn a little distance from the previous one, upon a suitable semi-cylin-

drical piece of wood, and over which a sliding collector can be moved, making contact with the wire by a spring on its under surface, so as to include any desired length of it in the circuit. The wire must be thick to avoid overheating. Fig. 54 represents a rheostat with a double coil of wire, and a resistance of from 0 to 10 ohms in 120 subdivisions.

In the graphite rheostat, a variable length of a very thin layer of this substance can be brought into the circuit. Dr. Gaertner makes use of a number of discs of a porous material, which are impregnated at a red heat with finely-divided carbon, the respective resistance of the discs depending upon the degree of saturation with the carbon. The discs are separated by plates of brass. A number of

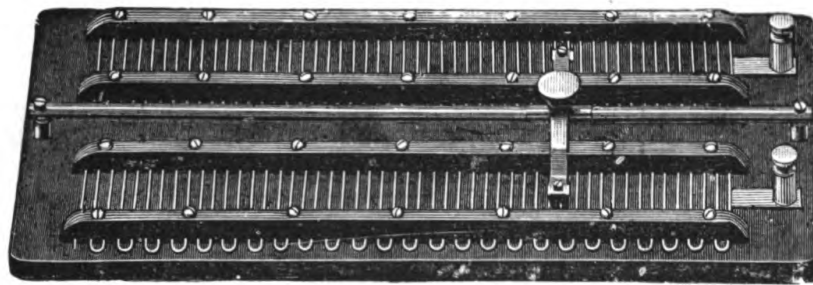

FIG. 54.—SIMPLE RHEOSTAT.

these are placed in a split tube and pressed tightly together by a screw. One electrode is attached to the first brass, and the other by a sliding arrangement can be caused to make contact with the brass pieces between the various carbon discs; a scale indicates the resistance, which can be made to reach 100,000 ohms. In a more simple form made by Schall, there are two very small soft graphite pencils free from metallic lead, along the surface of which a sliding piece makes contact by a spring; they will not take more than 500 m.a. current without heating.

### Liquid Rheostats.

For galvanic treatment the liquid rheostats are suitable. The principle on which they depend is the intercalation in

the circuit of a certain amount of a poorly conducting fluid, such as water, acidulated water, or a solution of sulphate of copper or of zinc.

Such an instrument can be readily improvised by filling an oblong dish, such as a tooth-brush holder, with acidulated water, and by placing in it the two ends of the wire from a battery with a galvanometer in the circuit. It will now be observed that the current-strength will vary with the distance apart of the ends of the wires. This simple instrument can be made more serviceable by fastening the end of each wire to pieces of lead or iron (a large bullet answers fairly well), so as to make them retain the position they are placed in. Fig. 55 represents one I have constructed out of a glass pen and pencil holder; the electrodes are two heavy pieces of copper, which

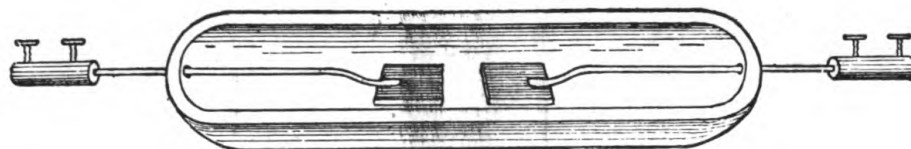

FIG. 55.—SIMPLE LIQUID RHEOSTAT.

are cut of a size to slide comfortably along the bottom of the glass dish. A hole is bored through each end of the dish above the water-level, for the passage through it and support of a thick copper wire from the electrode; the fluid may be a dilute solution of sulphate of copper, but ordinary water to which a little milk has been added offers a greater resistance, and is much more easily obtained. The table on p. 61 will give an idea of the relative resistances of the two solutions; the resistance offered by a rheostat, when the electrodes are as widely separated as they can be, should be at least equivalent to 2,000 ohms.

The commercial instrument consists of a glass tube on a stand, inside which a wire with a disc at its extremity can be made to move (Fig. 56), and at the bottom of which another disc is secured with a wire passing directly to a terminal on the stand.

If a great resistance be required the tube can be filled with pure water, but usually a strong solution of copper sulphate is used, and the discs and wire are also of copper,

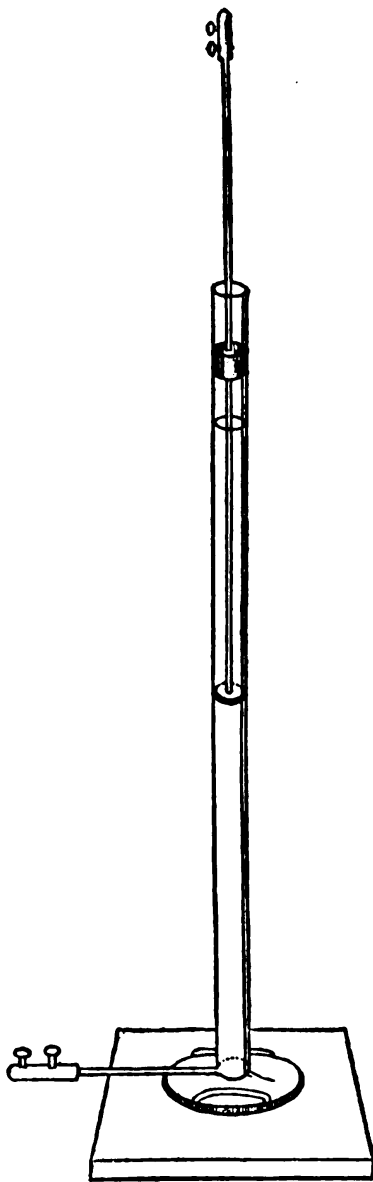

FIG. 56.—ORDINARY LIQUID RHEOSTAT.

to diminish polarization ; the weaker the solution, after a certain point has been passed, the greater the resistance.

If sulphate of zinc solution be used, the discs and wires

should be of amalgamated zinc, and the solution should be a saturated one. If, however, the solution be diluted until semi-saturated, its resistance will be unaltered, and the current-strength will remain the same.

In Dr. Milne Murray's rheostat there are two tubes, with the discs at their bases connected by a metallic conductor, and there is a special arrangement for raising or lowering the movable discs; such an arrangement permits of the introduction of a much greater resistance and of a finer graduation.

It is better to measure the resistance of the liquid rheostats by one of the methods mentioned above (the alternating current, bridge and telephone is the best), with the movable disc at various distances from the fixed one, and to mark the side of the tube with the results, so as to have some idea of the resistance you are introducing when using it. Such estimates are, however, only approximate, for changes are continually occurring in the fluid and electrodes through polarization and other causes which alter its resistance. By consulting the table at p. 61, an idea of the different resistances offered by the various fluids used in rheostats can be gained.

A good rheostat should be portable, simple, calibrated, and, if required for galvanic treatment, should be capable of throwing in a resistance, when necessary, at least equivalent to that of the body. The liquid rheostats, it will be seen, fail in some of these requirements, and their cheapness is their main recommendation.

For cautery work, a German silver wire rheostat, with a sliding contact as already described, is used; and for the laryngoscopic lamp a similar instrument with a somewhat higher resistance, say from 0.1 to 10 ohms.

### Rheophores.

The wires that connect the electrodes to the battery are termed 'rheophores.' They are usually made of several strands of fine copper wire twisted together, and insulated by cotton, silk, or indiarubber. This is done to give them

pliability, but as the fine strands are easily broken, and may give rise to much annoyance and pain through the sudden breaking of the circuit, it is better to use plain insulated copper wire of about No. 18 gauge in galvanic and faradic applications, and of about No. 14 gauge in using the cautery or the light.

### Electrodes.

Of electrodes there is every variety, according to the special purpose for which they are required.

Instead of the copper cup and sponge, flexible metal electrodes of standard sizes (*vide* p. 187), with removable wash-leather or flannel covers, should be employed. The resistance of these covers, even when thoroughly moistened, is considerable. In a pair tested by me it amounted to 60 ohms. The adhesive electrode made by Messrs. Nehmer and Co. relieves one of the necessity of holding the electrode in position. If the surface be moistened with warm water, this electrode will, after a little temporary pressure, adhere fairly firmly to the skin.



FIG. 57.—MAKE-AND-BREAK ELECTRODE HANDLE.

It is often a convenience to be able to make and break the current without having to remove one's hand from the electrode. Fig. 57 represents an electrode-holder fitted with an arrangement for making and breaking the current.

A convenient form for a large indifferent electrode is that furnished by a number of small pieces of carbon enclosed in a cover in such a way as to form a flexible pillow (Fig. 58).

### Current Combiner.

Dr. De Watteville's key for galvano-faradization is an arrangement to permit of the galvanic and faradic currents being used simultaneously. Fig. 60 represents the con-

nections. When the arms are on the side marked G, the galvanic current passes to the terminals ; when they are

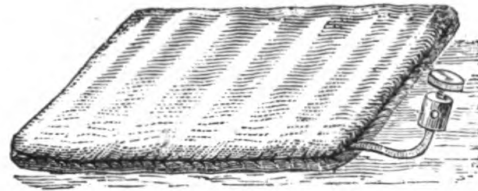

FIG. 58.—PILLOW ELECTRODE.

pulled over to F, the faradic current ; and when they are placed in an intermediate position, both currents. The

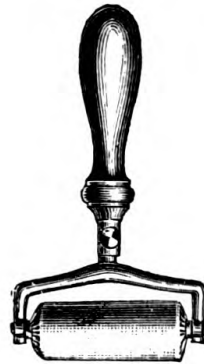

FIG. 59.—ROLLER ELECTRODE FOR LABILE APPLICATIONS.

convenience of being able to pass immediately, without removing the electrodes, from galvanism to faradism, or *vice versâ*, or to combine the two, is very great.

### Care of a Battery.

It is a question whether it is best to keep one's stationary battery in the consulting-room or in a cellar beneath ; if the cells are kept in a cupboard in the consulting-room they are close at hand, and any apparent break in connection can be at once rectified, and the resistance of the long wires leading to the cellar is avoided. In my own installation, I find that with thirty large Leclanché cells in the cellar there is a considerable loss\* in conducting the current through this distance ; this loss could be reduced

\* This loss is both in current-strength and in voltage.

by using larger wires. Moreover, a dial collector can be used, while if the battery is in a cellar it would be inconvenient to have to bring the number of branch wires that are required for a collector through such a distance, and the current-strength is best regulated by a powerful rheostat in the consulting-room, two heavy wires only carrying the current from and back to the cells. On the

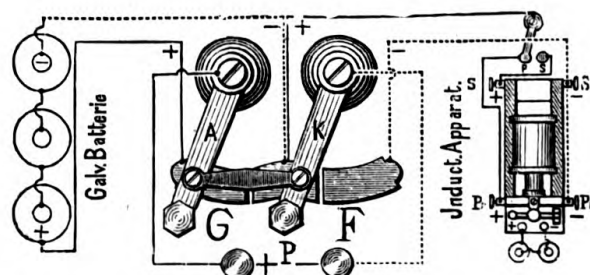

FIG. 60.—DIAGRAM OF CONNECTIONS OF DE WATTEVILLE'S KEY.

other hand, cells keep best in a cool place. Fig. 61 is that of a simple form of current-interrupter that it is best to interpose in the circuit of the long wires at the cellar end; it consists of two plates of brass having hollow places between them to receive a brass peg. The plates are connected by the binding screws to the divided wire. The

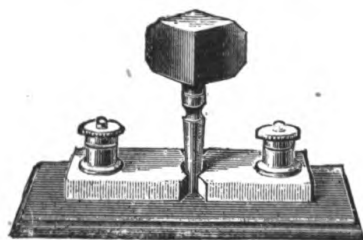

FIG. 61.—CURRENT-INTERRUPTER.

peg can be left in when the cells are in frequent use, but should be kept out on other occasions.

A useful arrangement to disconnect the cells entirely from each other, and so to prevent short-circuiting, which always goes on more or less when a large number of cells are connected in series, has been brought out by Mr. Fleming, of Teviot Place, Edinburgh, and is termed by



him a 'Cut-out.' The wire from every fifth cell, instead of being connected to the sixth cell, is brought up to the element board, and is there fastened to a small brass piece, while from another brass piece just opposite the first one the wire to the sixth cell passes. In the case, then, of fifty cells, there would be twenty such pieces of brass, and every group of five cells would be entirely disconnected from the next group. When the cells are required, suitable plugs of brass, fitting the spaces between all the brass pieces, and fastened to a rod of ebonite that is hinged at one end, can be at once lowered into position, and thus the cells are readily placed into connection. This cut-out can be improved by the addition of a rod lined with parallel brass strips like that of the Planté commutator, but made to slide in and out between the brass pieces when the other rod is raised out of the way (Fig. 62). The two end brass pieces must for this arrangement be connected with the two terminals of the battery instead of with the cells. If the hinged rod be brought into position, and it should, of course, have no connection with the end brass pieces, the cells will be connected in series, while if the sliding-rod be pushed in, the groups of cells will be connected in parallel, the current being led to the terminals by the two end brass pieces. Such a commutator is very suitable for a cautery and light battery, the plates of each cell being severally connected to alternately opposite brass pieces; when light is required, the hinged rod is used and the cells are connected in series; in the case of the cautery, the sliding-rod can be pushed in any desired distance until the platinum be hot enough. This obviates the necessity of a rheostat.

The zincs that are used in bichromate of potash, Bunsen and Daniell cells, require frequent amalgamation; this is done by first cleaning the zinc, then by dipping it into a solution of sulphuric acid (1 to 10), and then by running mercury over it and rubbing it in with a piece of flannel or a tooth-brush until the whole surface is quite bright. The zinc should not hiss when replaced in the acid. If the

salt creeps over the sides of the Leclanché cells, the whole cell should be taken apart, the glass vessel washed, the

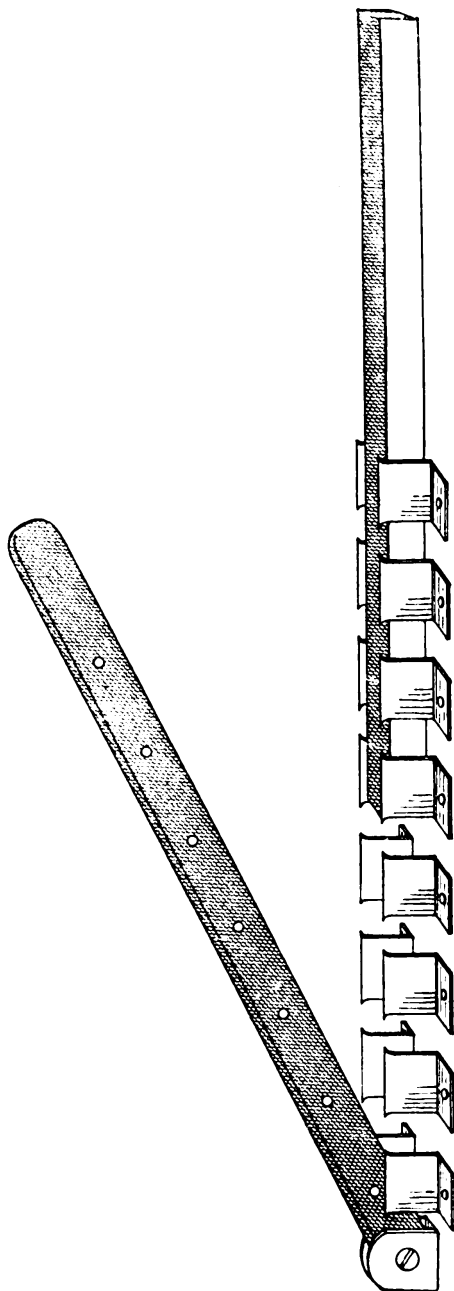

FIG. 62.—THE AUTHOR'S CUT-OUT AND COMMUTATOR.

margins paraffined or vaselined, and the solution of ammonium chloride diluted. The zincs in these cells only

require occasional reamalgamation. All brass connections on the element board, etc., should be kept scrupulously clean, and the ends of wires should be kept bright with emery-paper. If the battery seems after a time to fail, and no faults can be found in the electrodes, rheophores, or connections, careful search must be made for the offending cell. If the battery be provided with a double dial collector this will be easy. With a galvanometer and a moderate resistance in circuit, bring each cell successively and individually into circuit, and pick out the one that fails in causing a sufficient galvanometric deflection; examine and make good any faulty connection with it, and if none can be found, unscrew the connections, and take the cell out and clean it, reamalgamating and replacing the zinc, and refilling the cell with fresh ammonium chloride solution.

If the collector be a single-handed one, collecting cell by cell, the task will also not be difficult; the cells must be slowly brought into circuit with a galvanometer and a high resistance—1,000 ohms, if possible—included; then, as the addition of each cell should in the case of Leclanché's cause an additional deflection of 1.5 m.a., the failing cell can be picked out. If, however, the collector collects three to five cells at a time, the process will be more tedious and difficult; but the same general plan must be pursued, and the group of cells that do not give the proper amount of galvanometric deflection must be first localized, and then each individual cell of the group must be taken out, connected with a galvanometer, and tested.

## CHAPTER IX

### FARADIC ELECTRICITY

IN 1831 Faraday discovered that a current of electricity could be momentarily induced in a closed circuit by advancing to it or withdrawing from it a magnet (Fig. 63).

He followed this up by finding that a wire carrying a current had the same effect as the magnet (Fig. 64),

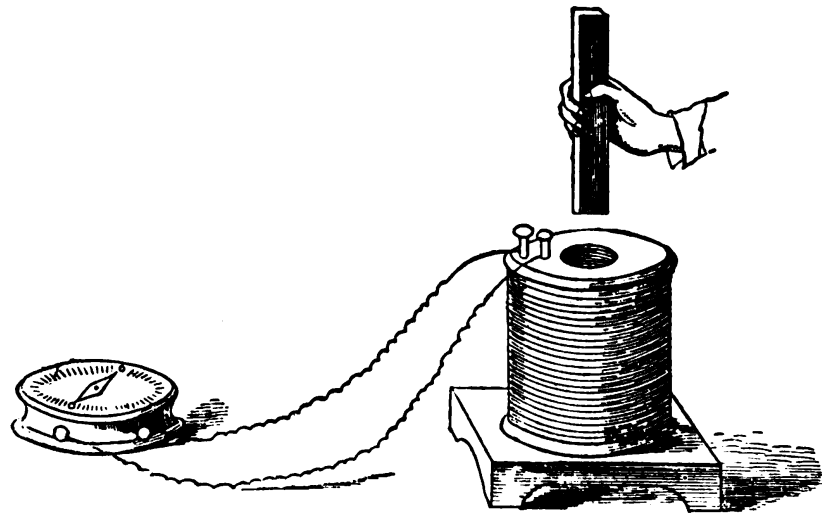

FIG. 63.—INDUCING ACTION OF A MAGNET ON A CLOSED CIRCUIT.

for such a coil of wire acts in all respects as a magnet. Further, he found that, if two circuits were placed near to each other, the making or the breaking of the circuit in the one would induce momentary currents in the other; this is, of course, merely equivalent to the previous statement, for by the making and breaking of the current in

the primary circuit we cause, as it were, a current-carrying wire to approach to and recede from our secondary circuit with exceeding velocity and from infinite distance.

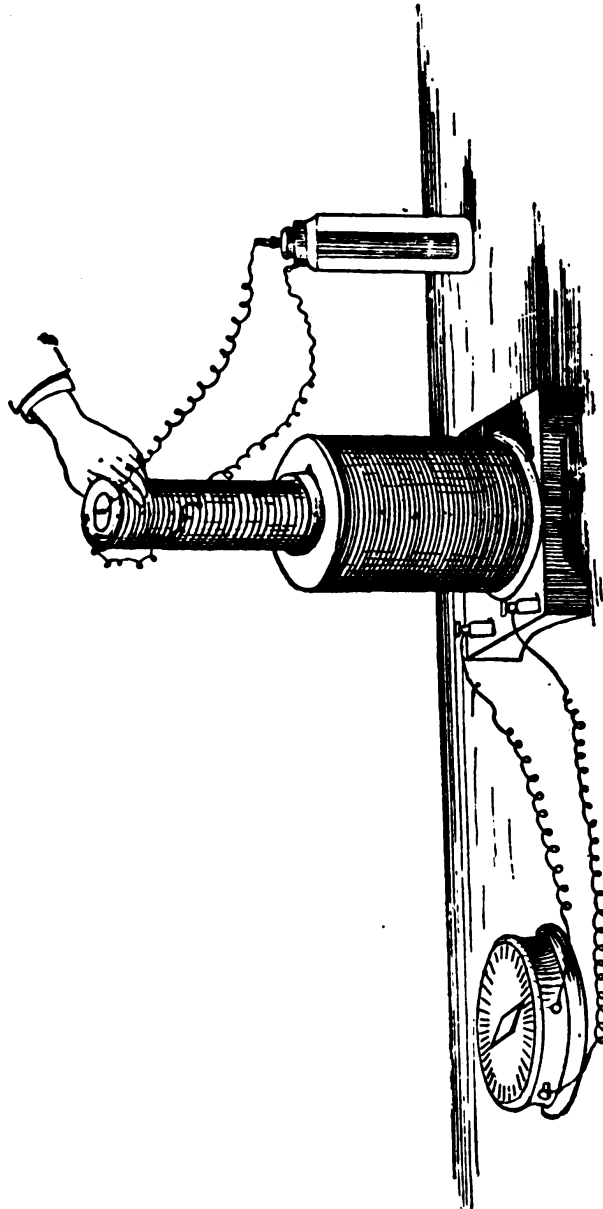

FIG. 64.—INDUCING ACTION OF A CURRENT UPON A CLOSED CIRCUIT.

He also found that if the current in the primary be suddenly increased or diminished, as by inserting or withdrawing plugs in a box of resistance coils (Figs. 65 and

66), similar momentary currents will be induced in the secondary.

These effects can be enormously magnified if we multiply the primary and secondary wires by coiling them, well insulated from each other, on a cylinder (Figs. 68 and 69).

Further, the more rapidly the magnet or the primary

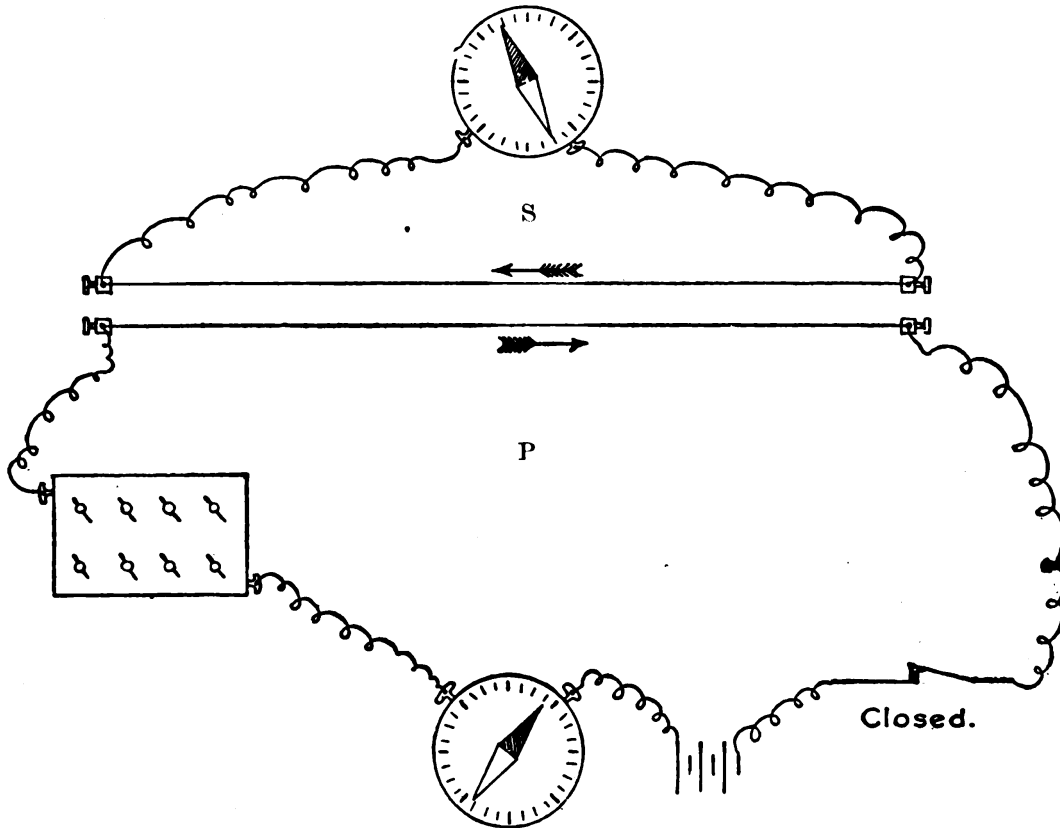

FIG. 65.—CURRENT IN OPPOSITE DIRECTION AT CLOSING.

coil is made to approach to and recede from the secondary, the stronger will be the induced current.

If a core of soft iron, nickel, or cobalt be placed within the primary coil, it will be found that the induced current is again strengthened, for as the core becomes magnetized by the current in the primary, we are now adding on to the inducing action of our primary current the inducing action of a magnet also. (The permeability of the iron core leads to a concentration of the magnetic lines of force.)

The current that is induced in the secondary circuit is in the *opposite* direction to the primary current at *making*, but in the *same direction* at *breaking*.

A glance at the two diagrams (Figs. 65 and 66) will make this plainer ; the circuit P is the primary one, and it includes a battery, a galvanometer, and a key. The

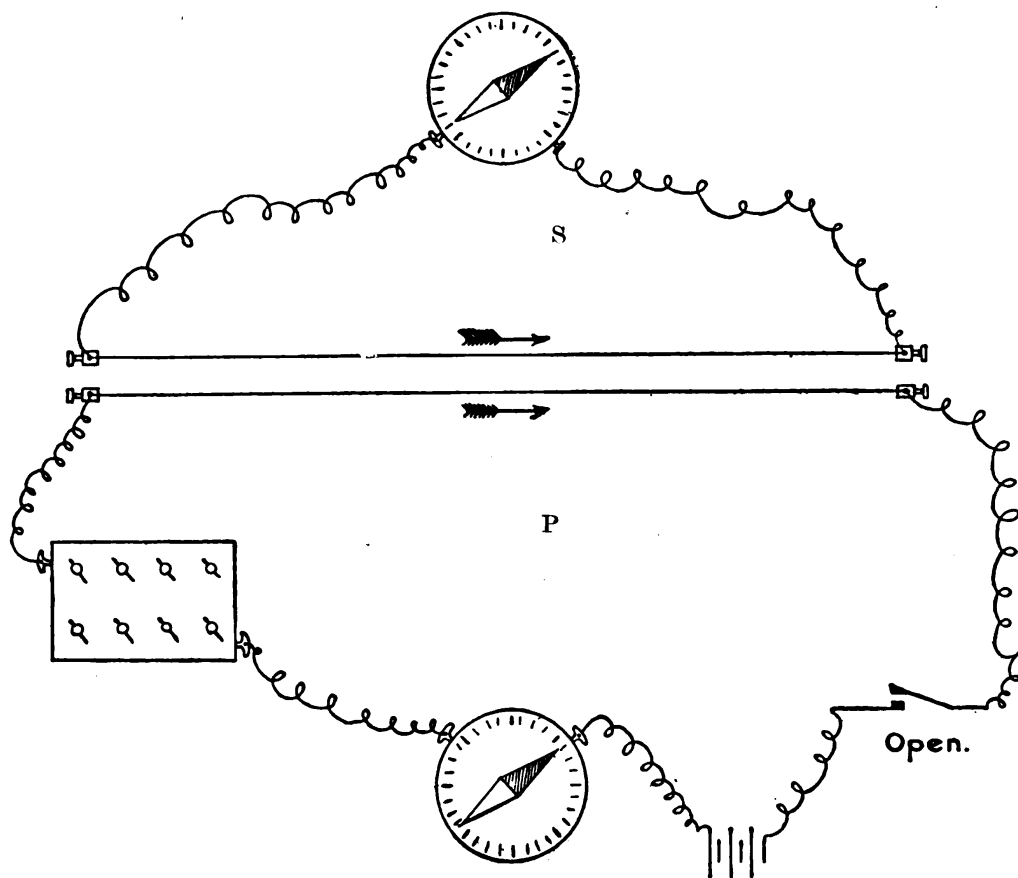

FIG. 66.—CURRENT IN SAME DIRECTION AT OPENING.

circuit S is the secondary, and it includes a galvanometer. In Fig. 65 the current is represented as being made, and in Fig. 66 as being broken ; and it will be observed from the direction of the arrows, as well as from the galvanometric deflections, that the two currents, inducing and induced, are *opposed* to each other at *making*, but are in the *same direction* at *breaking*.

Faraday's law is as follows :

If any conducting circuit be placed in the magnetic field of a permanent magnet or of an electric current, then, if by either a change of relative position or a change of strength of primary current a change is made in the number of lines of force passing through the secondary, an electromotive force is set up in the secondary proportional to the rate at which the number of included lines of force is varying.

The direction of the current induced in the secondary is explained by Lenz's law. In all cases of electro-magnetic induction the induced currents have such a direction that their reaction tends to stop the motion which produces them. The law of the conservation of energy is thus obeyed.

#### **Extra Current or Self-induction.**

A current is also induced in the neighbouring coils of the primary wire when the circuit is opened or closed ; it is called the 'extra current,' or current due to the counter E. M. F. of self-induction ; and following the same laws, it opposes and weakens the primary current on closing, and is in the same direction and strengthens the primary current on opening. It is for this reason that we see a spark at the moment of opening the circuit, to obviate which a condenser is used, into which the current can flow when the circuit is opened. Such a condenser also has the effect of still further weakening the current at closing by the electricity of opposite electromotive force that it has stored up, and of strengthening it at opening by making the break more sudden and complete. The extra current is usually collected in medical coils, and used as the 'primary current' (Fig. 67).

We have seen that in the secondary coil there is induced a momentary current in the opposite direction at closing the primary circuit, and one in the same direction at opening.

During the 'continuous flow' of the current in the primary there is no observable current in the secondary.



The opening current in the secondary is more powerful than the closing, and this for two reasons :

1. The galvanic current in the primary coil does not at once attain its full strength on closing, particularly if a condenser be used.

2. The current due to self-induction opposes the establishment of the primary current.

But when the primary current is opened, it is both at its own full intensity, and it is also strengthened by the

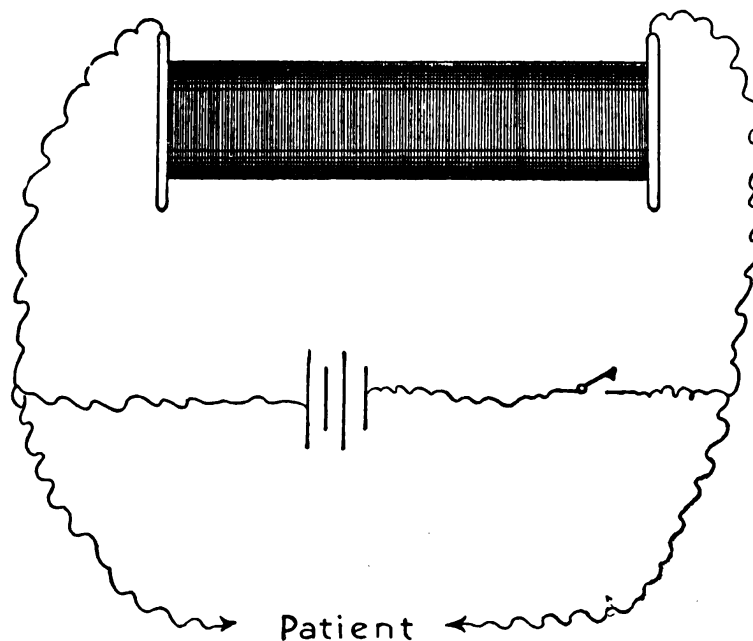

FIG. 67.—DIAGRAM OF METHOD OF COLLECTING THE PRIMARY CURRENT.

self-induction current, and hence it has a much more powerful effect upon the secondary. What we have observed may be tabulated as follows :

Momentary currents of 'opposite' E. M. F. are induced in a closed circuit by—

1. The approach of a magnet.
2. The magnetization of an electro-magnet lying near the circuit.
3. The approach of a wire conveying a current.

4. The making of a current in a neighbouring wire.
  5. The increasing of the strength of that current.
- And, *vice versâ*, momentary currents of 'similar' E. M. F. are induced in a circuit by—
1. The recession or demagnetization of a magnet.
  2. The recession of a wire carrying a current.
  3. The breaking of the current in a neighbouring wire, or the decreasing in strength of such a current.

### The Induction Coil.

The induction coil is constructed upon these principles. It may be regarded as an arrangement for producing an induced current of high E. M. F., by the inducing action of a current of lower E. M. F. whose circuit is alternately opened and closed in such rapid succession as to produce an almost continuous series of induced currents. As, however, we cannot on physical principles get more out of the machine than we put in, we only obtain the increased E. M. F. by a sacrifice of current-strength. If, for the sake of an illustration, we put in 2 watts (p. 31), consisting of 1 ampère at 2 volts, we can only get the 2 watts out, even supposing that the machine is a perfect one and that there is no loss. Now, the construction of the machine is such as to return us our 2 watts in the form of volts rather than in that of ampères, say  $1\frac{1}{10}$  ampère at 200 volts. A transformer (p. 124) depends upon precisely the same principles, but it acts the other way; we put in volts and get out ampères. We may apply the popular saying about ordinary mechanical machines—that what is gained in power is lost in speed—by saying: 'What is gained in E. M. F. is lost in current-strength.'

In the Dubois-Reymond sledge-coil (Figs. 68 and 69) there is a stand, at one end of which is a strong upright, to which the primary coil is firmly attached, while the secondary is arranged to slide in a groove along the stand, so that it can be made to approach, and if necessary completely cover, the primary coil. A scale is attached to the stand and a pointer to the secondary coil, so that the

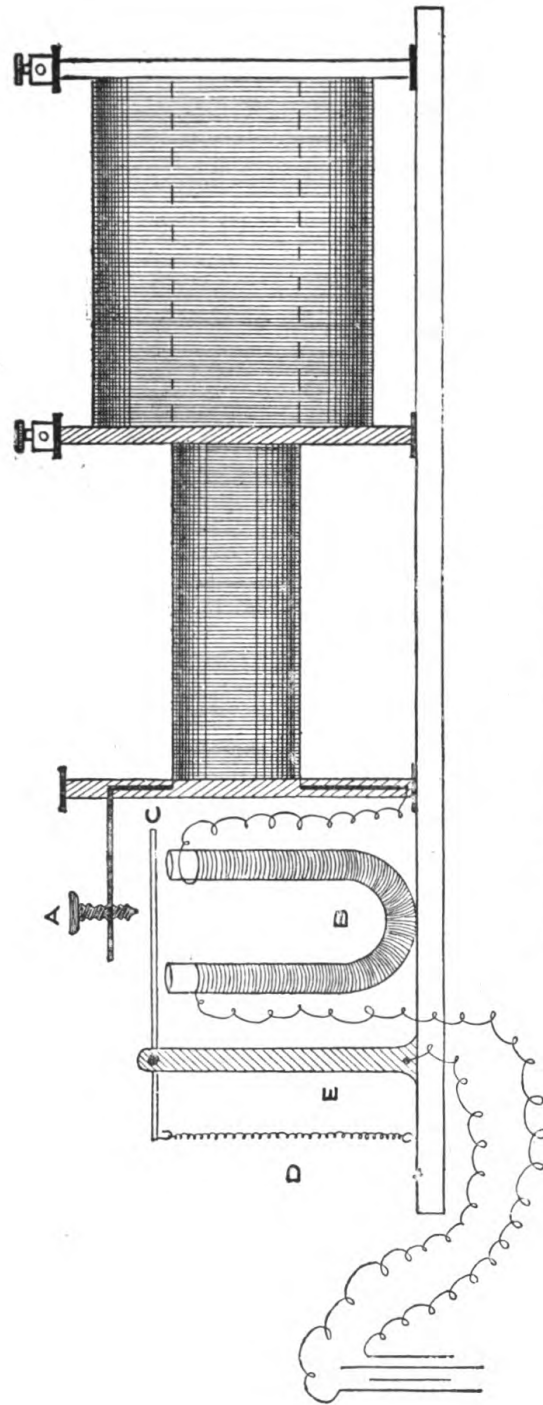

FIG. 68.—DUBOIS-REYMOND COIL.

position in which the latter may be (the distance from the primary coil) may be accurately noted.

A bundle of soft iron wires covered with an insulating varnish, and enclosed in a light case, which is graduated, can be placed within or withdrawn to any required degree, according to the graduations, from the primary coil. This forms an electro-magnet, which is more rapidly magnetizable and demagnetizable than a solid one would be, because the induction currents, which would be set in circulation in a solid rod, are partly eliminated.

The primary coil is wound with a few turns of thick wire to diminish resistance and self-induction.

The secondary coil is wound with very many turns of

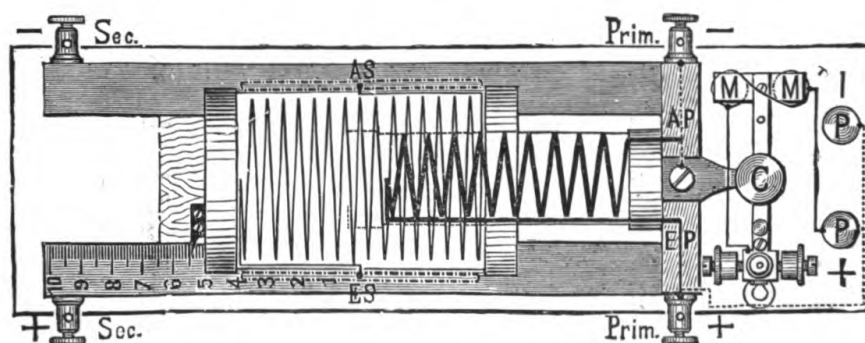

FIG. 69.—DIAGRAM OF INDUCTION COIL FROM ABOVE.

thin wire, which must be most carefully insulated from each other to prevent the high electromotive force liberated from short-circuiting. The greater the number of the coils the greater the mutual induction and electromotive force. The increased resistance may, therefore, be disregarded.

To open and close the primary circuit with rapidity, a mechanical arrangement, known as Neef's hammer, is employed (Fig. 68). When a current is passed through the electro-magnet B, it attracts to it the movable armature C, which at other times is kept in contact with the platinum-faced screw A by the spring D.

If the circuit be closed in such an arrangement, the current, entering by the pillar E, will flow through the

armature C, and along screw A into the primary coil, returning round the electro-magnet B, which therefore becomes magnetized, and attracts the armature C, breaking its contact with A. The circuit now being broken, the electro-magnet B becomes demagnetized, and the armature C is at once pulled up to the screw A, and the circuit is completed again. The current is thus being constantly made and broken by the alternate movements of the armature C. For large coils a separate motor interrupter is best (see p. 320).

Perhaps the most convenient primary cell for working

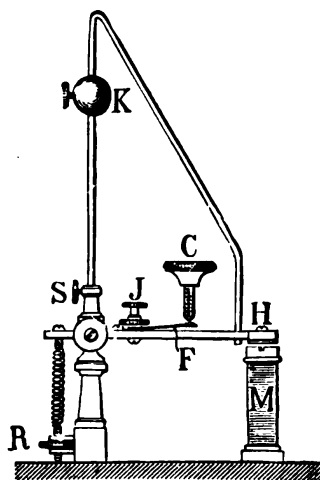

FIG. 70.—PENDULUM FOR REGULATING THE RATE OF VIBRATION OF THE ARMATURE H.

a small induction coil is a bichromate, but two large Leclanchés will do equally well for medical purposes. An arrangement for regulating the rate of the interruptions by means of a pendulum and movable ball K attached to the armature H (Fig. 70) of the Neef's hammer is of much service.

In some faradic machines there is a metallic cylinder, which can be pushed between the primary and secondary coils, and which by the various currents that are induced in it acts as a sort of screen to the secondary, very much weakening the inducing action of the primary upon it.

The strength of the secondary current depends upon—

1. The strength of the primary current.
2. The relative lengths of the wires in the two coils.
3. The distance between the coils.
4. The presence of an internal electro-magnet.
5. The presence or absence of a metallic shield.
6. The rate of the interruptions (for within certain limits the more rapidly these are made the less tolerable is the current).

The third method, which admits of accurate measurement by means of the scale, is the most useful. The alternating currents do not deflect a magnetic needle, because the effect of the flow in one direction is immediately counterbalanced by a flow in the opposite direction. For the same reason electrolysis (p. 167) is not produced, nor can secondary batteries be charged. They serve, however, for lighting and cautery purposes, provided their current-strength is sufficient.

The medical induction coil only differs from the ordinary ones in that the secondary wire is neither so long nor so thin, and that it is unprovided with a condenser; the E. M. F. is, therefore, not raised to so high a pitch, and the current-strength is relatively greater.

### Magneto-electric Machines.

We have seen that currents can be induced by the approach or recession of a magnet. Machines on this principle are termed magneto-electric (the dynamo belongs to this class), and have been for some time in common use, especially among the laity; Mons. d'Arsonval has quite recently strongly advocated the use of a modified form.

In the ordinary form (Fig. 71), a large permanent horse-shoe magnet is enclosed in a box, and in front of its poles two bobbins of soft iron wrapped with insulated wire can be made to revolve rapidly by means of multiplying cog-wheels turned by a handle, which is fixed externally. As each bobbin approaches and recedes from the poles, two

currents of opposite E. M. F. are induced in it ; these are collected by suitable connections and utilized. They are of an alternating character, and produce in a much diminished degree the same class of effects as the secondary current from an induction coil.

If, as in some instruments, a commutator to turn the successive currents into the same direction is employed, the effect produced will be that of a rapidly-interrupted galvanic current, whose E. M. F. will depend principally upon the number of the turns of the wire in the coils, and upon the rapidity with which they are made to rotate. By a sufficiently rapid rotation, the interruptions become



FIG. 71.—MAGNETO-ELECTRIC MACHINE.

less and less appreciable, until an almost continuous current is obtained.

In Gaiffe's machine the magnet is also wrapped with wire, which much increases the total efficiency. The modern dynamo is constructed upon the same principle, an electro-magnet being substituted for the permanent magnet, and the coil of both magnet and armature put into connection.

The advantage the small magneto-electric machines have over the ordinary battery or coil is that they are always ready, rarely get out of order, are very portable, and require no attention ; they are therefore useful in emergencies. Further, the current they yield is less painful

and stimulating than that from an induction coil. Their advantages are more than counterbalanced by the labour of turning them, and the difficulty of maintaining anything like a uniform strength of current.

Mons. d'Arsonval's modification of the ordinary magneto-electric machine permits of an alternating current with sinusoidal variations. In the ordinary machine the variations of the current are not uniform; a glance at the diagrams (Fig. 72) taken from Mons. d'Arsonval's tracings

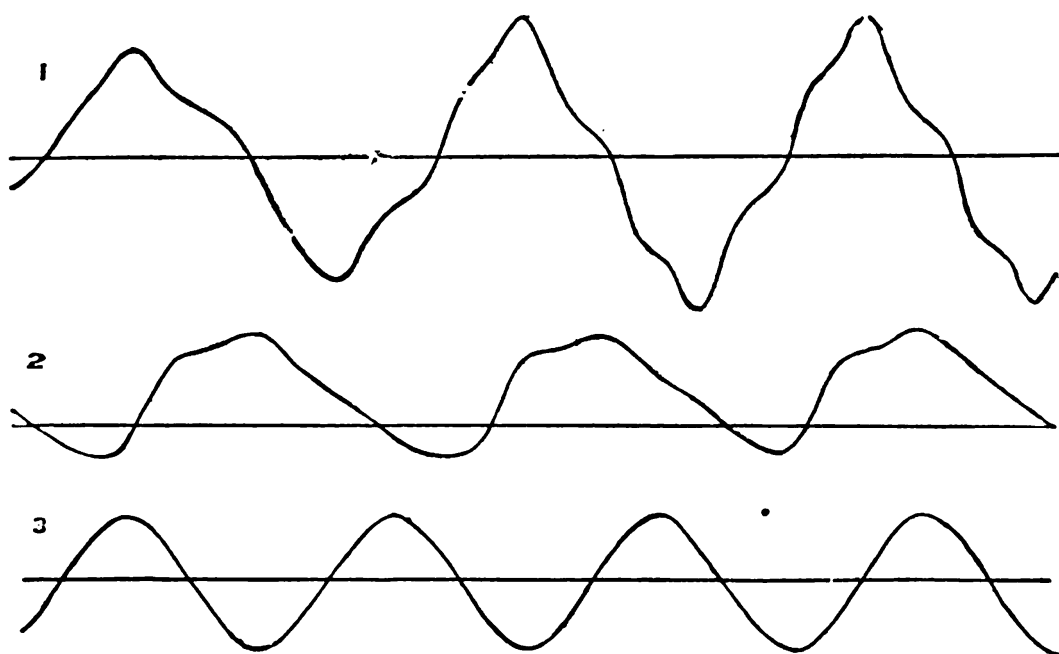

FIG. 72.—CURVES TO REPRESENT THE CURRENTS OF MAGNETO-ELECTRIC MACHINES.

will exhibit this. The first tracing demonstrates the curves of the alternating electrical waves yielded by a good ordinary magneto-electrical machine, the second those of a similar machine provided with a commutator to turn all the currents into the same direction. This object has evidently not been tully attained. The third represents the sinusoidal variations of Mons. d'Arsonval's machine. The coils in this machine are fixed, and a circular steel magnet is revolved by cogwheels before them. The current is taken from the two extremities of the coils, and



all collectors and commutators are dispensed with. The current so obtained is extraordinarily smooth ; there are no breaks in it, and the alternating waves are perfectly uniform. These properties render it valuable in therapeutics. Sinusoidal machines are now largely employed for local application and for supplying baths with alternating currents. Fig. 73 represents a small sinusoidal machine supplied by Schall which can be worked by three or four accumulators or six large Leclanché or dry cells ; the strength of the sinusoidal current is regulated by the sledge coil. If the current be required for a bath, a more

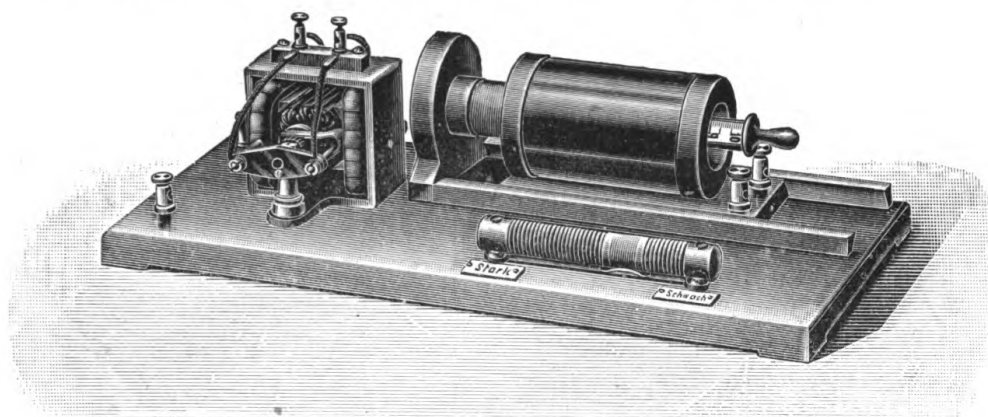

FIG. 73.—SINGLE PHASE SINUSOIDAL MOTOR.

powerful instrument (Fig. 74), supplied with current from the electric light continuous current main, will be necessary. Such an instrument is a motor transformer. A small motor is driven by the current from the main, and to this motor is attached a dynamo wound to yield the desired voltage and current. Either single phase or three-phase currents can be obtained from this instrument.

### Dynamo Currents.

The dynamo is merely an improved magneto-electric machine.

In the current from a steam-driven dynamo, the disadvantages of the ordinary hand-driven machines are almost done away with, and in towns lighted by electricity

the main may be tapped, and the current brought directly to a switch-board in the consulting-room.

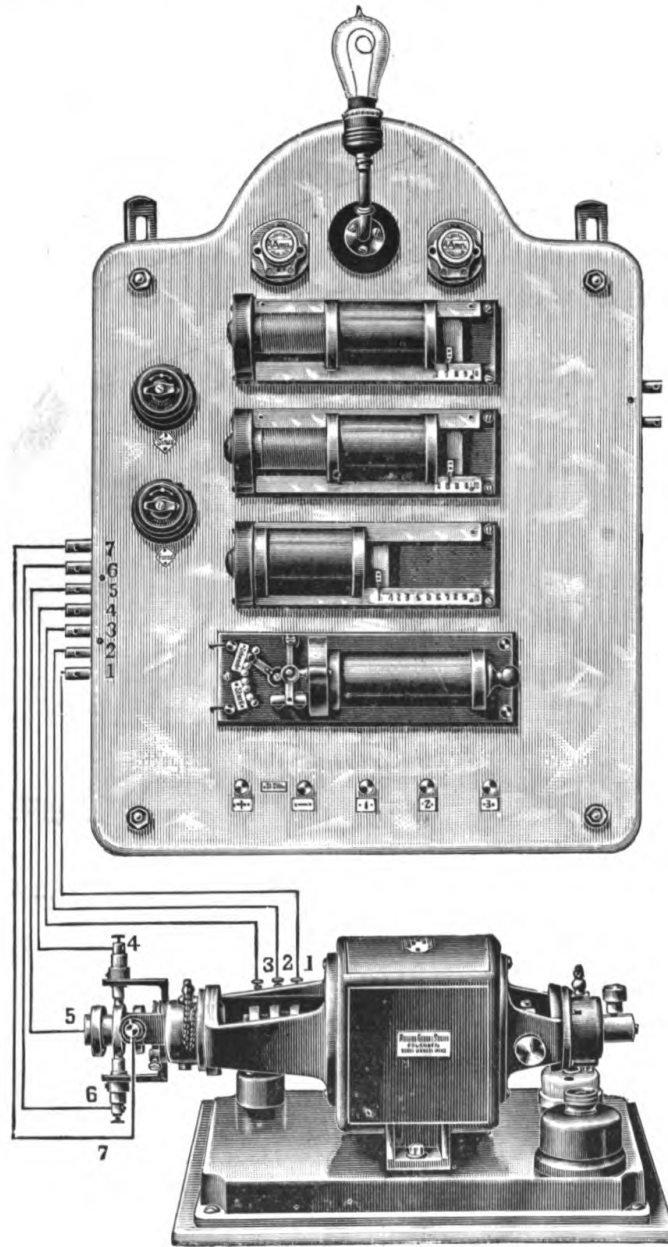

FIG. 74.—SINGLE PHASE OR THREE PHASE SINUSOIDAL MOTOR.

If the current supplied to the lamps be a continuous direct one, it can, by being passed through suitable

rheostats, or through a motor transformer, be used for galvanization, for working an induction coil, and for light and cautery.

Except for the first cost, the motor transformer is the most economical method of utilizing electric light currents for cautery and light. Fig. 75 represents a motor transformer which takes in current at 100 or 230 volts, and at from 1 to 3 ampères, and yields a current at 10 volts and up to 25 ampères; this instrument first changes the continuous current from the main into a sinusoidal one, and then transforms it down by means of a closed iron circuit

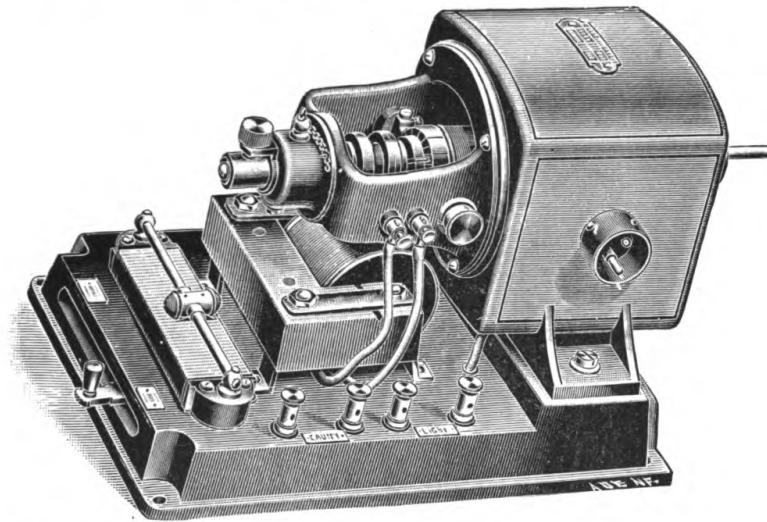

FIG 75.—MOTOR TRANSFORMER FOR LIGHT, CAUTERY, AND SINUSOIDAL TREATMENT.

transformer or induction coil. It can be used for cauteries, lamps, and for driving drills, and even for sinusoidal treatment. Still another method of reducing the voltage of the continuous current from the main is to use an interrupter transformer (Fig. 76), which is essentially of the same nature as an induction coil, but which is wound to reduce instead of to increase the voltage. The disadvantage of this class of instrument is the interrupter, which burns away and requires a good deal of attention.

If the current be an alternating one, it can be passed through a simple transformer, and, for galvanization

through a motor transformer or a Nodon valve, and can be used for the same purposes.

### Rheostat Apparatus for use with Direct Currents from the Main.

A leading principle must be never to place the patient in direct series with the mains, no matter how great the intercalated resistance. The wires that pass to the patient

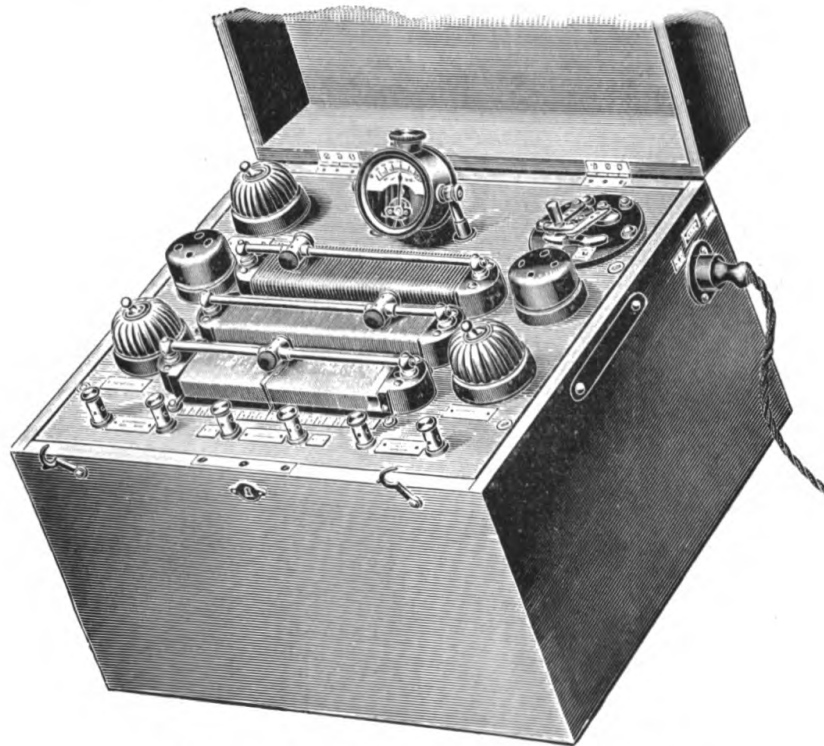

FIG. 76.--INTERRUPTER TRANSFORMER.

should form part of a branch circuit or shunt to the main circuit (see p. 87).

The main wires should be connected together through a coil of resistance wire and a lamp of a resistance sufficient to reduce the current to manageable dimensions, and then a little of this current should be tapped off for use with a patient by a branch wire.

Under these circumstances no possible danger or risk to the patient can be occasioned.

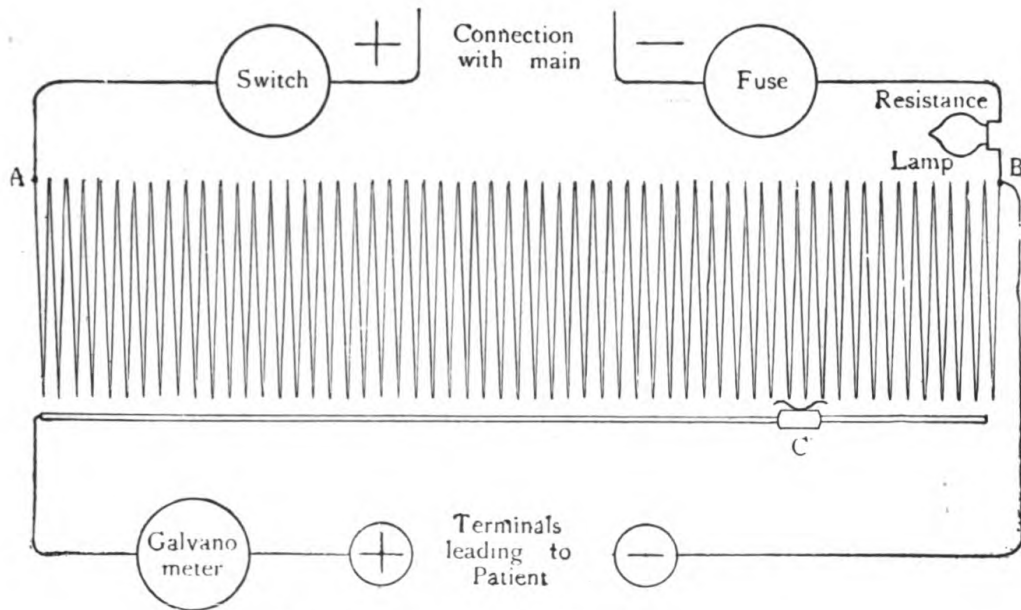

FIG. 77.—PORTABLE SWITCH-BOARD.

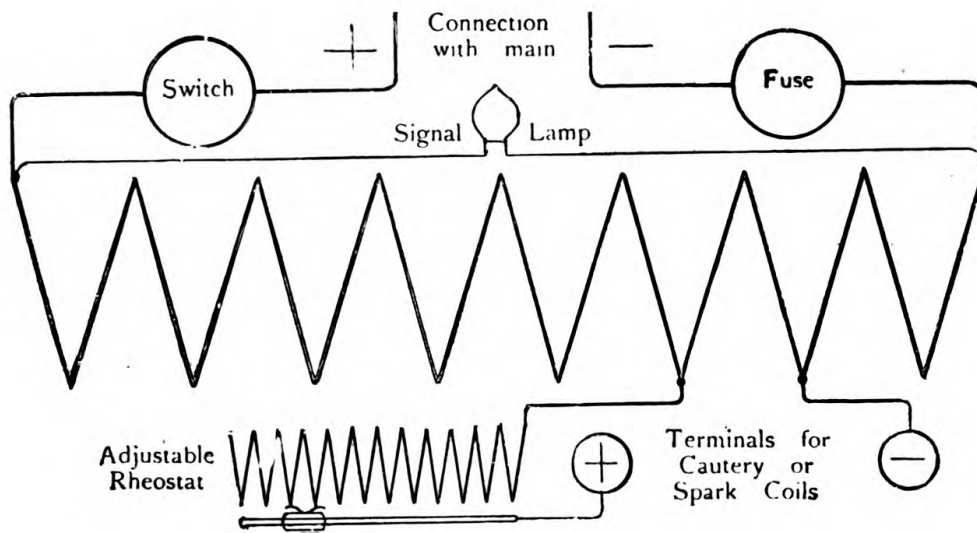

FIG. 78.—DIAGRAM OF CONNECTIONS TO MAIN FOR CAUTERY AND X-RAY COILS.

In order to be able to conveniently vary the voltage and current-strength in the branch circuit which passes to the patient, one end of the branch wire is attached to a sliding piece C (Fig. 77), which can be moved along the resistance wire in the main circuit so as to make contact with it at various positions. The voltage tapped off will vary with its position, and will be at its maximum when the two ends of the branch wire are as far from one another as the sliding contact C will permit, but when C is near B the voltage will be small. This sliding rheostat is called a 'volt-regulator,' and it is usually constructed so as to give a range of from 0.1 volt to 60 volts. An advantage of the lamp is that it serves to warn the operator that the current is flowing, and that by exchanging it for one of a different candle-power variations in the voltage and current-strength can be obtained. A precisely similar arrangement (Fig. 78) is used for heating a cautery or for supplying current for large coils, but the resistance wire must now be made very thick, so as to carry a large current without overheating.

In the admirable switch-board (Figs. 79 and 80) of the late Dr. Milne Murray, these principles have been elaborated. In addition to the volt-regulator, there is an induction coil, a voltmeter, a De Watteville key, a milliampère meter with a shunt and short-circuiting key, two lamps, one for the galvanic and the other for the faradic circuits, and a testing key; the latter is to enable the operator to ascertain without injury to the milliampère meter whether the plug which connects the apparatus to a lamp-socket is properly inserted or not. With the ordinary bayonet-catch pattern of lamp-socket the switch-board plug might be inserted the wrong way, so that the current would tend to drive the milliampère meter needle away from the scale instead of forwards along the scale; but with the old-fashioned concentric wall-plug this could not occur. The following are the directions, issued in the Edinburgh Royal Infirmary, for using the Milne Murray switch-board :





FIG. 79.—MILNE MURRAY SWITCH-BOARD.

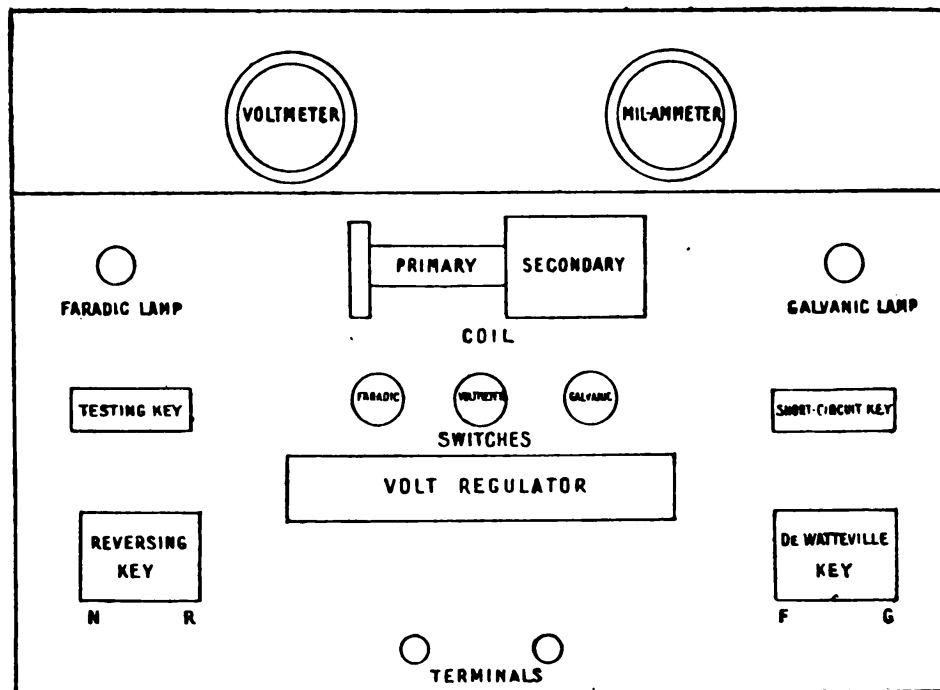

FIG. 80.—DIAGRAM OF ARRANGEMENT OF MILNE MURRAY'S SWITCH-BOARD.

1. See that the lamp-switches are open, the slider of the volt-regulator at zero, the De Watteville key at G, and the reversing key at N.
2. Insert the plug into a convenient wall-socket.
3. Close the 'Galvanic' switch, which should cause the right-hand lamp to glow.
4. Open the 'Short-circuit' key, and move the slider of the volt-regulator about 1 inch from zero.
5. Press down the 'Testing' key. If the index of the milli-ampère meter moves to the right—*i.e.*, over the scale—the plug is properly inserted. If it moves to the left—*i.e.*, off the scale—the plug is wrongly inserted, in which case reverse the plug.
6. To obtain *Galvanic* currents—
  - (a) Close the 'Galvanic' switch.
  - (b) Close the 'Voltmeter' switch.
  - (c) Put the De Watteville key to G.
  - (d) Move the slide of the volt-regulator to the left until the volt meter indicates the required voltage.

The polarity of the electrodes can be reversed by putting the reversing key to R. When the key stands at N the polarity of the terminals is as marked.



## 130 A MANUAL OF PRACTICAL MEDICAL ELECTRICITY

7. In all cases where the electrodes are being applied intermittently, as in testing out reactions or in labile applications, the short-circuit key must be closed to protect the Galvanometer. This key should only be opened when an exact measure of the current passing is required.

8. To obtain *Faradic* currents—

- (a) Put the De Watteville key to F.
- (b) Pull out the Secondary Coil to the end of the slide.
- (c) Close the 'Faradic' switch. This should cause the left-hand lamp to glow and the vibrator to act. If the latter remains still, start it with a touch of the finger.
- (d) Adjust the rate of vibration by means of the upper screw.
- (e) Regulate the strength of the current by altering the position of the Secondary Coil.

9. To obtain *Galvano-Faradic* currents—

- (a) Put the De Watteville key on the intermediate studs, midway between G and F.
- (b) Close all the switches.
- (c) Regulate the strength of the currents by the volt-regulator and coil as above.

10. Interruptions of the current may be made by the key on the handle of the electrode.

11. Reversals of the current are made by the reversing key on the switch-board.

12. Before removing the feeder-plug all the switches must be opened, and before putting the instrument away the short-circuit key must be closed and the slide brought to zero.

13. *The terminals must on no account be brought into metallic contact, as this exposes the milliampère meter to the risk of permanent damage.*

14. *The greatest care must be taken to prevent drops of water falling on the switch-board, and if such an accident should happen the moisture must be at once carefully removed.*

15. *If by any such accident a drop of water should fall on the wire of the volt-regulator, the current must be at once shut off, the wire carefully wiped as dry as possible, and the instrument must not be further used for at least two hours, to make certain that all moisture has disappeared.*

16. If the instrument fails to act, it must not be interfered with, but should be sent at once to the Central Department for examination and adjustment.

### Apparatus for use with Alternating Currents from the Main.

If the current be an alternating one, a simple transformer or a motor transformer or a current rectifier is used. A simple transformer consists essentially of an induction coil, arranged to work the reverse way, and, therefore, to return ampères rather than volts (see p. 115), through the primary circuit of which the current from the dynamo is passed; induced currents are thus obtained in the secondary, and of a strength proportional to the proximity of the secondary to the primary, and to the relative thick-

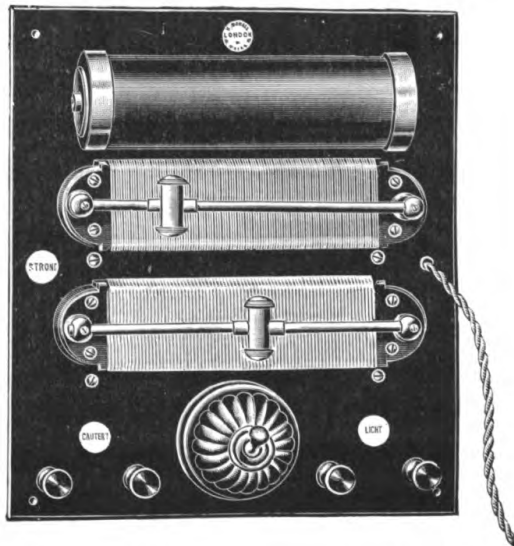

FIG. 81.—SIMPLE CURRENT TRANSFORMER.

nesses and lengths of the two coils of wire. Various secondary coils can be used, according to the purpose for which the current is required, and these can be wrapped upon the same cylinder, so as to obviate having to change it.

For heating the cautery a short coil of thick wire, to furnish a large current of low E. M. F., would be required, and so on. In the simple transformer (Fig. 81) there are two pairs of terminals; one pair supplies a current

suitable for cautery, the second pair a current suitable for the small incandescent lamps.

The alternating current obtained through such a transformer from a dynamo differs, as already mentioned, from the secondary current of an ordinary medical induction coil, as well as from that of the small magneto-electric machine. The current in each direction is equal in magnitude and of a sinusoidal character, and the interruptions are so rapid as to give the current much more of a continuous character; this renders it much smoother and pleasanter to the patient, so that a stronger current can be borne.

By means of a motor transformer an alternating current can be converted into a continuous one, and used for galvanization, electrolysis, and for charging accumulators. The instruments are expensive, costing from twenty to forty pounds; they consist of an alternating current motor, arranged to turn a continuous current dynamo (Fig. 82).

The same effect can be produced more cheaply by a 'Nodon valve' or rectifier. This consists essentially of a vessel containing electrodes of iron and of an aluminium alloy immersed in an electrolyte of saturated ammonium phosphate; if the 'valve' be placed in series with an alternating current it suppresses by the formation of an electrolytic resisting film on the aluminium one half of each wave (Fig. 13), and permits only unidirectional currents from the iron to the aluminium to pass through.

### Chief Physical Differences between Faradic and Galvanic Currents.

The faradic current from an induction coil alternates in its direction; that is to say, the current is being continually interrupted and reversed, the break current being much stronger than the make; the E. M. F. is very high (often about 200 volts in medical coils, but it may be much more), the current-strength very low; electrolysis of water is not produced, nor, except in infinitesimal amounts, of

solutions of salts. The effective current-strength cannot be measured by an ordinary galvanometer; one instrument for this purpose is an electro-dynamometer, which depends upon the electro-magnetic action between a fixed

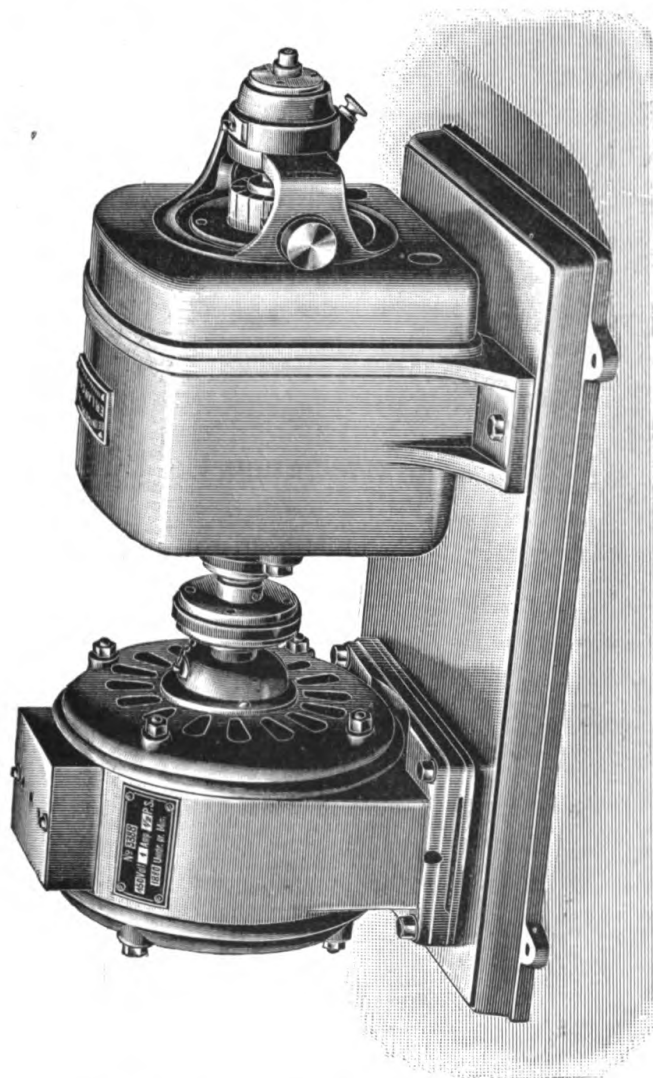

FIG. 82.—MOTOR-DYNAMO TRANSFORMER.

and a movable coil, through both of which the current passes. A hot-wire instrument can also be used (see p. 91).

The 'galvanic current' is a direct and continuous one, whose E. M. F. is relatively low and current-strength high; the electrolysis of water and of solutions of salts is produced by it. It deflects the galvanometer, and the deflec-

tions can be made to form an accurate index of the current-strength.

The 'extra' or 'primary' current, or current due to the counter E. M. F. of self-induction, occupies an intermediate place; it is a direct but rapidly-interrupted current with a high E. M. F. and a low current-strength, but the former does not attain to the degree obtained from the secondary coil; the current at break is very much stronger than the current at make. It possesses feeble electrolytic power, and it deflects the galvanometer.

The current from the usual 'magneto-electric machine' is alternating and interrupted, resembling that from an induction coil, but with the currents produced by the approach and recession of the magnet nearly equivalent in strength in both directions. If the armature be revolved slowly, the galvanometer needle will be deflected from side to side; if rapidly, it will remain almost stationary. The current-strength can be measured by the electro-dynamometer. Electrolysis is not effected.

By a proper commutator all the currents can be turned into the same direction, and then the galvanometer will be deflected and electrolysis produced.

The current from a dynamo may be 'alternating' or 'direct,' and is so rapidly interrupted as to be almost continuous. The E. M. F. for house-lighting is usually between 100 and 200 volts, and the current-strength through the lamps from  $\frac{1}{2}$  to 3 ampères.

If it be 'alternating' it does not deflect the galvanometer nor bring about electrolysis, but the current-strength can be measured by the electro-dynamometer or the hot-wire instrument. The current is of the same strength in both directions.

If it be 'direct' it does deflect the galvanometer and bring about electrolysis.

By the current-strength of an alternating current is meant not its maximum positive or negative value but its mean value; this is called the 'effective' or 'virtual' current.

## CHAPTER X

### SECONDARY BATTERIES

IF the current from two or more Daniell cells be passed, platinum electrodes being used, through water, it will be found, by having a galvanometer in the circuit, that the current very rapidly falls off, so that at the end of a minute or so it will probably have much less strength than it started with. If now the battery be quickly cut out, the galvanometer needle will be deflected for a short time in the opposite direction, showing that a reverse current obtains.

This phenomenon depends on polarization. As long as the battery current flows, hydrogen is collecting at the kathode and oxygen at the anode, to form, as it were, a new cell of opposite E. M. F., which, on being disconnected from the primary source of power, at once gives off a current in the opposite direction ; the latter is termed the polarization current, the former the polarizing current.

It is on this principle that secondary batteries, storage cells, or accumulators, as they are often called, are constructed ; and the polarization current, it will be observed, depends really upon a chemical action, just in the same way as the polarizing current may be supposed to do ; for the latter, in passing through the simple secondary cell we have described, splits up the compound  $H_2O$ , forcing the hydrogen to accumulate at the kathode and the oxygen at the anode, so that when the polarizing current is withdrawn, it is by the recombination of these gases that the polarization current is produced.

The electrical energy of the polarizing current produces chemical energy, which in its turn can be made to reproduce the electrical energy, and the whole process can be many times repeated. The first useful secondary cell was made by Planté in 1860. It consisted of a vessel containing two electrodes of sheet lead, and a dilute solution of sulphuric acid; the electrodes, in order to obtain as large a surface as possible, are coiled round each other in the form of a spiral, but are everywhere prevented from touching by the interposition of pieces of indiarubber. The acid acts upon the lead to form lead sulphate, which, being deposited upon the plates, and being insoluble, protects them from any further chemical action of such kind.

When a continuous current from a battery or dynamo is passed through such a cell, it decomposes the lead sulphate, and, by causing oxygen and hydrogen to appear at the respective poles, it peroxidizes the anode to form lead dioxide, and deoxidizes the kathode to form metallic lead in a spongy form; this much increases its surface and power of retaining the gas. By discharging and then recharging in the opposite direction a sufficient number of times, the capacity of the cell becomes greatly increased.

In 1881 Faure much shortened the time taken in charging, and increased the capacity of the cell by covering both electrodes with red lead (minium),  $Pb_3O_4$ . The passage of a current converts this at the anode into the peroxide  $PbO_2$ , and at the kathode into spongy metallic lead, and in this way a comparatively thick layer of active substance is quickly obtained.

The modern accumulator is constructed upon essentially the same principles, but with various improvements. The plates are perforated grids (Fig. 83), the holes on the positive plate being filled with a mixture of red lead and sulphuric acid, and those on the negative plate with a mixture of litharge and sulphuric acid.

The electrolyte is a 10 to 20 per cent. solution, specific

gravity 1.170, of sulphuric acid. The E. M. F. of a secondary cell is about 2 volts, and the internal resist-

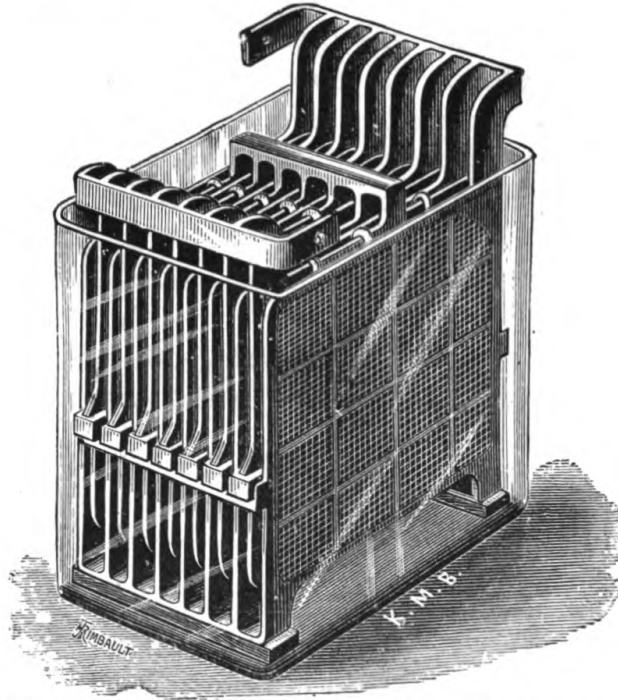

FIG. 83.—ACCUMULATOR IN GLASS VESSEL.

ance very low (less than 0.01 ohm); the current-strength is therefore high on short circuit.

Further, this strength is fairly maintained until the cell

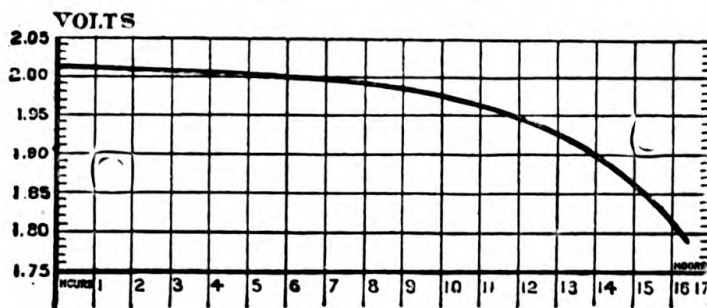

FIG. 84.—DRAKE AND GORHAM'S CURVE.

is nearly exhausted. The curve in Fig. 84 was determined by Drake and Gorham, and it shows that in a cell that will run usefully for about fifteen hours the E. M. F. does not fall to below 1.95 for the first twelve hours.



A secondary cell may be charged by three or more Daniells, or two Bunsens, in series (Fig. 85); all that is required is a continuous current at a higher E. M. F. than  $2\frac{1}{2}$  volts to overcome the opposing polarization current of the accumulator. If several have to be charged, they must be connected in parallel to keep the E. M. F. down, or a larger number of Bunsens would be required, and the charging current must naturally be kept up a longer time. The positive pole of the accumulator should be connected with the positive pole of the charging cells, and the negative with the negative, and the current should be maintained as a rule for about six to eight hours. It is well to have a galvanometer in the circuit to indicate the direction and strength of the current. It should be

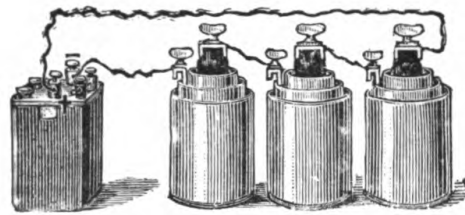

FIG. 85.—CHARGING A SECONDARY CELL.

discontinued when the solution assumes a milky appearance, technically boils—a phenomenon due to the evolution of free oxygen, of which the positive plates can now absorb no more. If a dynamo station be near, all trouble can be saved by sending the accumulators to be charged there; but it is better if the continuous current electric light mains be laid on in the house to do the charging one's self, so as to avoid the risk of damage by transit.

It is useful for this purpose to have a concentric wall plug with the two wires coming from it coloured, the positive one red and the negative one black. The accumulator must now be connected through a lamp resistance (Figs. 86, 87) to these wires, the positive wire to the red or positive pole of the accumulator, and the negative wire to the negative pole of the accumulator. When these connections have been made the plug may be inserted

in the wall socket, when the lamps will glow, but not so brightly as they would do if the accumulator were

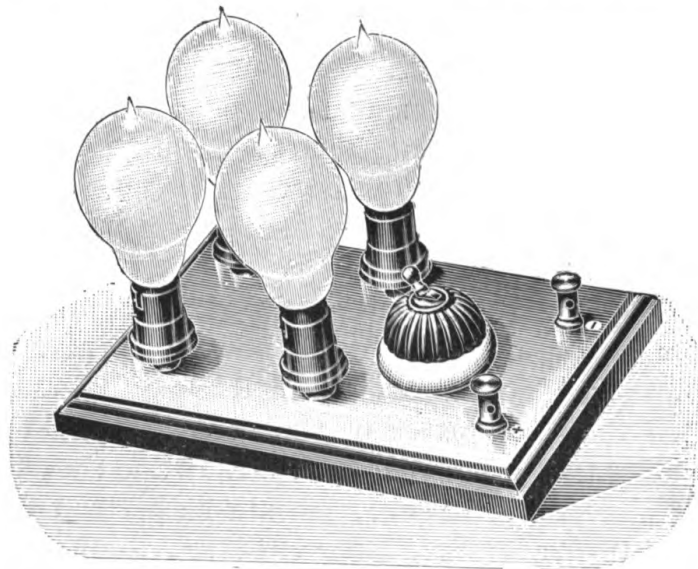

FIG. 86.—LAMPS IN PARALLEL FOR CHARGING AN ACCUMULATOR.

removed, while if by mistake the accumulator had been wrongly connected to the wires the lamps would glow

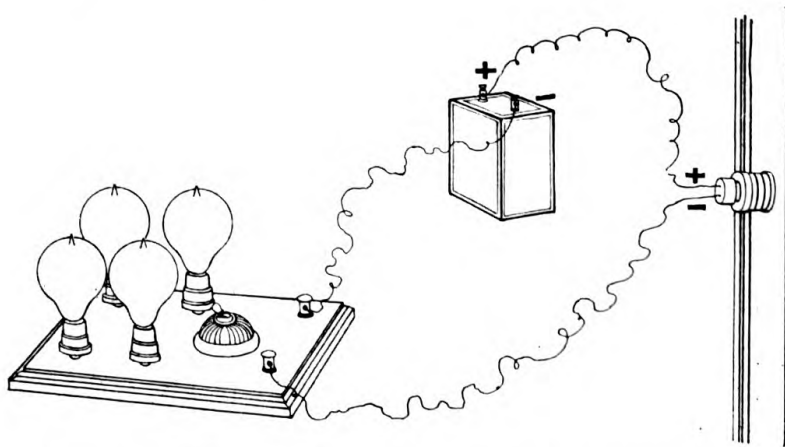

FIG. 87.—PLAN OF CONNECTIONS FOR CHARGING AN ACCUMULATOR FROM THE MAINS.

more brilliantly than they would do normally. This, then, may be used as a test as to the polarity of the main wires ;

the accumulator must be connected so that the lamps are dimmed. Another way of distinguishing the polarity of the wires is, keeping them well apart, to plunge them into water into which a pinch of salt has been thrown. Gas will be given off from both poles, but most will arise from the wire connected to the negative pole. Again, a piece of moistened litmus-paper will be coloured red by the positive pole and blue by the negative; in doing this experiment both wires must be made to touch the litmus-paper.

The strength of the current passing through the accumulator will depend upon the candle-power of the lamps and upon the number of lamps connected in parallel, and must be suited to the capacity of the accumulator; thus, if the capacity be 50 ampère hours (p. 142), and the accumulator be almost discharged, it would be better to charge it for twenty-five hours at a current-strength of 2 ampères than for twelve and a half hours at a strength of 4 ampères—that is to say, as a general rule, a small charging current for a longer time is to be preferred to a large current for a shorter time. Two sixteen candle-power lamps on the lamp-board (Fig. 87) connected to a 100-volt circuit will allow about  $1\frac{1}{4}$  ampères to flow, and four such lamps about  $2\frac{1}{2}$  ampères; thirty-two candle-power lamps will double these figures. If, however, the circuit be one of 200 volts, the current-strengths will be approximately halved. The charging current-strength can thus be very conveniently altered by varying the number and candle-power of the lamps on the board. The E. M. F. of the cell should be tested from time to time by a voltmeter (cell-tester); when fully and freshly charged this will be 2.5 volts per cell, but it rapidly falls when the charging current is cut off to 2.2 volts.

The degree of exhaustion of a cell can also be estimated by taking the specific gravity of the solution by a hydrometer (Figs. 88 and 89). When the cell is at exhaustion-point this will be about 1.150, and the further the cell is from this point the higher the specific gravity will be

until, when the cell is fully charged, it should be at about 1.21.

Great care should be taken not to exhaust the cell ; if this occur the plates become covered with white lead sulphate, which both increases the resistance and dimin-

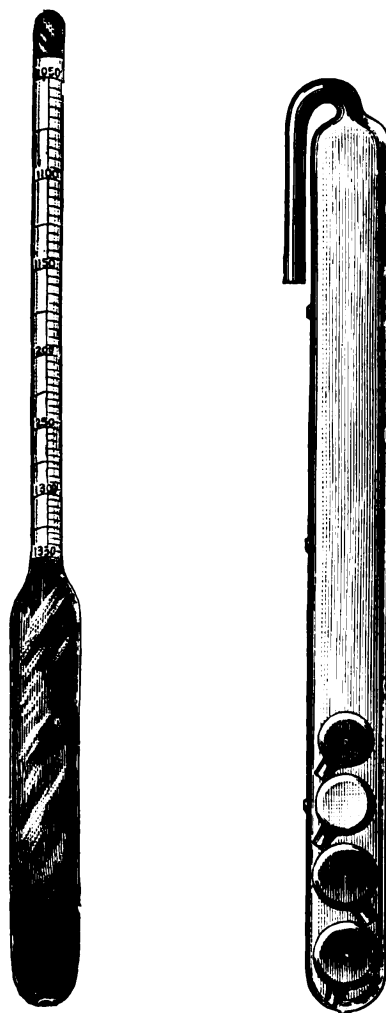

FIGS. 88 AND 89.—TWO FORMS OF HYDROMETER.

ishes the capacity. The cell should therefore be recharged when the E. M. F. has fallen to 1.9, and the density to about 1.150. But it is better practice not to allow it to fall to this point, but to keep it as fully charged as possible by frequent recharging once or twice a week.

Secondary cells are of most use to those medical men who use the Röntgen rays and the galvanic cautery and light ; they are, by reason of their great weight and expense, unsuited for general electro-therapeutic work.

Their 'advantages' over primary batteries are :

That, in consequence of their high E. M. F. and very low internal resistance, they furnish a relatively very strong current.

That the current-strength remains steady until the cell is nearly exhausted, and is not subject to the rapid falling-off which occurs in currents from most primary cells.

That the cell is always ready for action, for the zincs do not require to be lowered into the acid when a current is required, to be raised again immediately afterwards, as must be done with the bichromate of potash cells, the form of battery most used for cautery and light.

Some of their 'disadvantages' are :

Want of durability ; the lead plates become disintegrated after a time.

Want of portability ; they are very heavy, a small size for cautery weighing about 50 pounds.

Difficulty of recharging the cells one's self unless provided with the lighting mains.

Care necessary to see that the cells do not become exhausted.

A word may be added here as to the 'capacity' of the cells—*i.e.*, the length of time during which they are able to yield a current. This is usually measured in ampère hours (the product of the number of ampères the cell can maintain into the number of hours during which it can maintain the ampères), and a good cell can be expected to yield about 5 ampère hours per pound weight of the plates. The more slowly the current is taken the greater, as a rule, is the electrical efficiency. The greatest care should be taken to see that the cell is never, even temporarily, short-circuited ; such treatment may buckle the plates and loosen the paste.

### Choice of Batteries.

The nature of the various cells, their best arrangements, the accessories, and faradic apparatus, have already been

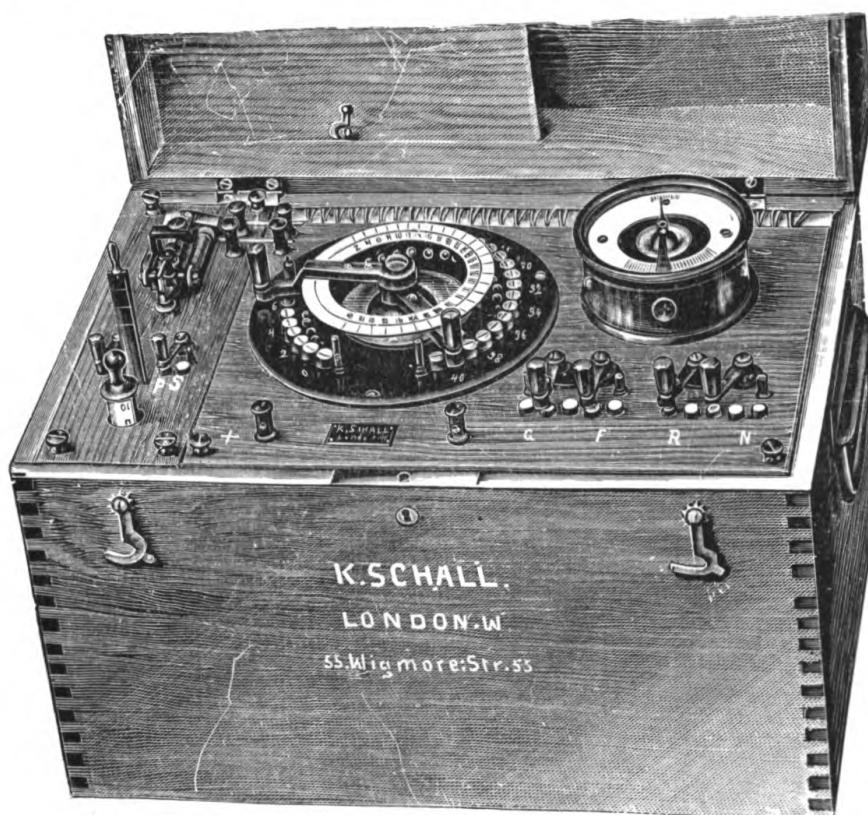

FIG. 90.—COMBINED PORTABLE GALVANIC AND FARADIC BATTERY.

individually considered. It remains to say a word or two about their combination.

To be enabled to make a proper use of electricity in general practice, a medical man must have at least two or three different kinds of apparatus (excluding static machines).

I. A combined or separate galvanic and faradic battery or switch-board in case the main is laid on, that would serve for galvanization, eletrolysis, electro-diagnosis, and faradism.

2. A battery for cautery and light.

A 'universal' battery would be a great desideratum, but is, for the following reasons, at present practically unobtainable :

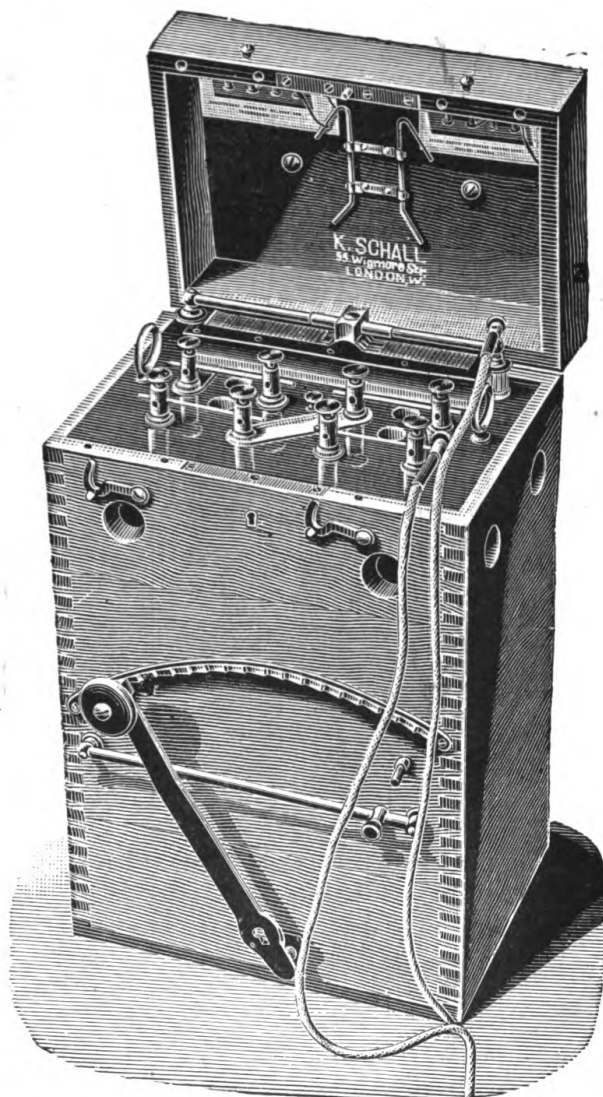

FIG. 91.—VOLTOLINI'S BATTERY.

For galvanization we require twenty to forty cells in series (small or large), which do not run down when the zincs are left in the solution, and in which there are, therefore, no strong acids, and which require but little attention.

For cautery work we require two to six cells in parallel, and they must be 'large' and of energetic action, and must therefore contain strong electrolytes, so that the

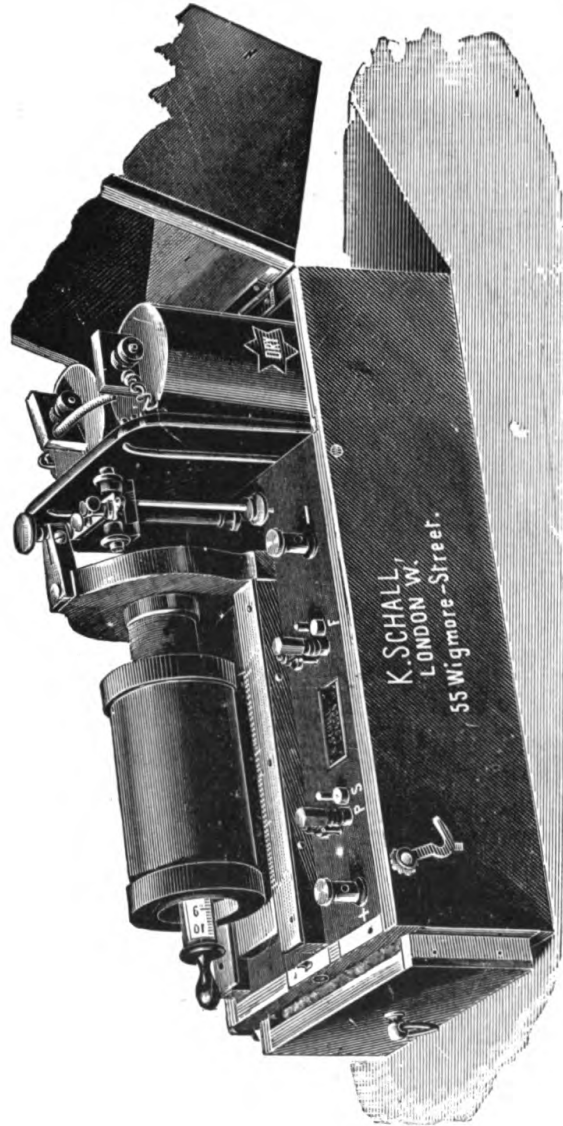

FIG. 92.—SLEDGE COIL WITH DRY CELLS.

zincs must be withdrawn after each application, or they would continue to be dissolved.

For a 'house installation,' a switch-board such as Milne Murray's attached to the electric light mains is much to be preferred, but failing this twenty to forty large-size

10



Leclanché's combined with an induction coil to be worked either by a couple of the Leclanchés or by a separate bottle bichromate, and kept in a cupboard or placed within an electrical cabinet, would probably be the most suitable and reliable battery for galvanism, faradism, electro-diagnosis, and electrolysis.

For cautery and light, a special bichromate or accumulator battery may be used.

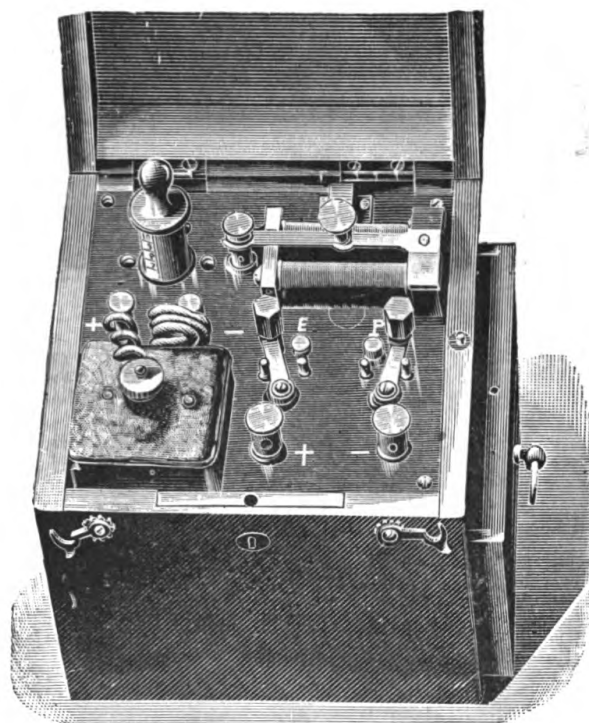

FIG. 93.—INDUCTION COIL WITH DRY CELL.

For portable purposes, a combined or separate galvanic and faradic battery composed of small dry cells (Fig. 90) is best.

For cautery and light, either Voltolini's (Fig. 91) portable bichromate battery, or a portable accumulator, such as the Lathanode or E. P. S. Q. type.

Fig. 92 is that of a good sledge induction coil energized by two dry cells.

Fig. 93 is that of a small induction coil with a dry cell.

In Reiniger's acid battery (Fig. 94) the carbons and zincs are fused together so as to insure a good connection ;

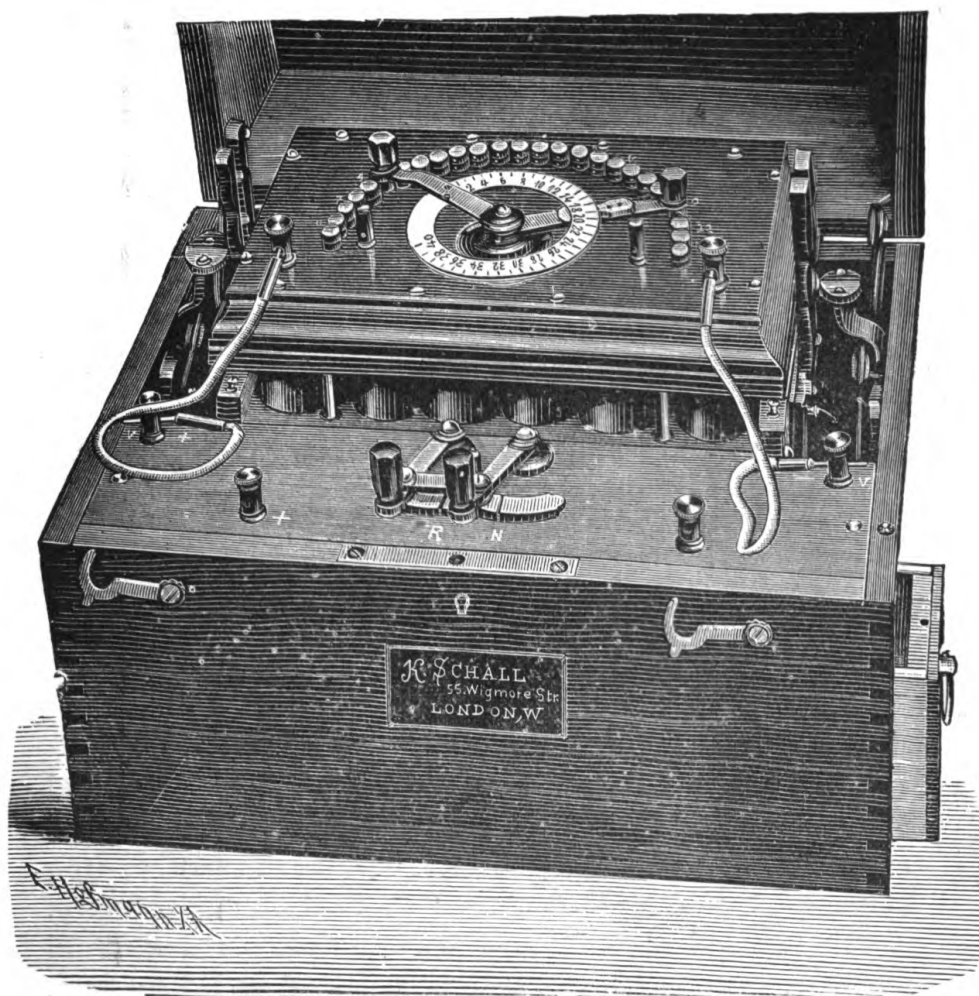

FIG. 94.—REINIGER'S BATTERY WITH AUTOMATIC PLUNGE APPARATUS.

the elements are easily renewed, and there are floats to prevent spilling.

PART II  
*ELECTRO-PHYSIOLOGY*

CHAPTER I

**PHYSIOLOGICAL EFFECTS OF ELECTRICITY**

THE relations of electricity to the body are many, and but imperfectly understood. They may be arranged for study into the following groups :

- Those that are purely physiological.
- Those that are purely electrolytic.
- Those that are purely cataphoric, etc.

The first group comprises the study of the electrical effects spontaneously produced by the tissues of living creatures, and the stimulating, sedative, nutritive, etc., effects produced by the external application of electricity.

The natural electric phenomena, fully treated of in works on physiology, can only be summed up briefly here.

**Natural Electrical Phenomena.**

All living creatures are the seat of electrical manifestations, which appear to attain their greatest intensity in certain fishes, particularly in the torpedo. These phenomena have been especially studied in the nerves and muscles (the electrical organs of the torpedo appear to be analogous to muscles, but yielding electrical discharges in place of contractions), but it is almost certain that they are to be found in all tissues that are the seat of vital

changes. The various chemical processes, the heat changes, and the mechanical variations of volume and surface, that are continually going on in the body, are sufficiently obvious sources of natural electricity. For their study a delicate astatic galvanometer and non-polarizable electrodes should be used.

The contact of any metal with moist tissue is sufficient to develop a current ; the only conductor which does not, when used for this purpose, develop a difference of potential is the normal saline solution (0.6 solution of NaCl). Dubois - Reymond's electrode consists of a thoroughly amalgamated zinc wire dipping into a saturated solution of zinc sulphate enclosed in a tube, whose lower end is filled with a plug of modeller's clay, moistened with the saline solution. D'Arsonval's electrode consists of a silver wire, surrounded with chloride of silver, dipping into the saline solution, which is contained in a tube drawn out at one end into a point.

### Cutaneous Currents.

Tarchanoff has studied in a series of careful experiments the electrical conditions of the healthy skin. One non-polarizable electrode is placed upon a part of the skin that is rich in sweat-glands (palm of the hand, plantar surface of foot, etc.), the other is placed on a part not so provided (outer surface of arms, etc.). These are put into circuit with a very delicate galvanometer. Provided the patient is absolutely tranquil and at rest in both body and mind, and that the room is also perfectly quiet, no current is observed. If he be gently tickled or stroked by a brush or feather, it matters not where, a cutaneous current will develop after a latent period of two or three seconds, passing in the external circuit from the part that is less rich in sweat-glands to the part that is more rich. The palm, therefore, becomes negative, to the outer surface of the arm. The current continues for some minutes. Mental emotion and intellectual exercises, especially mathematical, produce the same effects ; so, too, does

muscular movement, however slight or far removed. The movement of a toe produces a current in the hand, so that it would seem that it is not the muscular movement so much as the mental effort resulting in the motor discharge that is the cause of the cutaneous current.

### Muscle and Nerve Currents.

The principal electrical phenomena that have been observed in the muscles and nerves can be divided into two classes :

1. Continuous currents, occurring during repose.
2. Intermittent currents, occurring during activity.

#### I. Continuous Currents.

If the longitudinal surface of a fresh piece of living muscle be connected by a conductor with the base (transverse section or tendon), with a delicate galvanometer in the circuit, impolarizable electrodes being employed, a weak current will be found to be passing from the former to the latter. The lateral (longitudinal) surface is therefore positive to the transverse section. A muscle might, therefore, be regarded as a galvanic cell ; its lateral surface forming its + pole and its tendon its - pole.

The equator of the lateral surface (the point midway between the two ends) exhibits the highest potential (is most +), the centre of the transverse section exhibits the lowest potential (is most -); the strongest current is therefore to be obtained by connecting these two points. Should, however, the current be difficult to obtain, or should it fall off, it can be temporarily renewed by making a fresh transverse section.

A fresh nerve yields a similar current ; its longitudinal surface is positive to its transverse section. The E. M. F. of the muscle current is about 0.05 volt, and of the nerve about 0.025 volt.

Physiologists are agreed that these currents do not really exist in the normal uninjured tissues. The surfaces of an untouched muscle would appear to exhibit no

potential difference, and the fact that the current can be renewed by making fresh transverse sections supports Hermann's view, that the currents of repose are due entirely to alterations produced in the tissue by its removal from the body ; that whenever a portion of a muscle is dying, it becomes negative to the living part. After death of the muscle the currents cannot be obtained.

## II. Intermittent Currents.

The intermittent currents occurring before and during a contraction (*negative variation* of Dubois - Reymond) can be shown as follows. The existence of a current of repose having been observed in a muscle prepared as in the last experiment, the muscle is stimulated (chemically, mechanically, or electrically) ; the needle of the galvanometer will now return towards zero, and remain there until the contraction is over—*i.e.*, the previously observed current of repose will experience a diminution. This sudden variation in the current-strength can be made to stimulate another muscle (Matteuci).

The same phenomenon can be observed in a nerve.

The current of action appears to obey the following laws :

1. It appears along with the contraction (Burdon Sanderson).
2. The point stimulated (from which the contraction starts) becomes negative to the rest of the muscle.
3. The negative wave travels at the same rate as the muscular wave.
4. In the nerve it travels at the same rate as the nervous impulse.
5. It lasts as long as the wave of contraction.
6. It never surpasses in strength the current of repose.

Meissner has lately observed that a positive wave is occasioned by mechanically stretching a muscle.

The explanation of the production of the muscle-current is much disputed.

Dubois-Reymond has suggested that a muscle may be

considered to be composed of molecules, each of which has two negative ends and a positive equator ; when these are arranged in proper order the current of repose is present, while a partial rotation sets up the current of action. (Compare theory of magnetism.)

D'Arsonval considers the current of action to be due to the electro-capillary forces investigated by Lippmann ; all mechanical deformations, however feeble or rapid, modify the electrical potential ; before a muscle contracts an internal molecular change occurs which alters the surface tension and sets up a difference of potential. Thus it is easy to construct artificial muscles (of thin indiarubber tubes divided by porous discs into compartments, the latter containing mercury and acidulated water) which will yield, accordingly as they are stretched or contracted, currents of opposite E. M. F. In this way the negative variation on contraction and the positive variation on extension can be explained.

Hermann's views are now generally accepted. He states that muscle becomes negative under two conditions :

1. In activity.
2. When dying.

The electrical discharges of the torpedo fish would appear to be of the nature of currents of action.

The passage of a constant current through a nerve is accompanied by certain variations in its own continuous currents of repose. These variations are termed electrotonic currents.

The effects produced by the external application of electricity differ according to whether they are obtained by the physiologist on excised or exposed nerve and muscle preparations, or by the physician through the skin on normal and uninjured tissues. The former, by careful isolation and preparation, and by the direct application of his electrodes, can insure that the whole of his current is passing through the structure, and can thus obtain definite results ; but the latter has no means of calculating

what proportion of his current is traversing the part he may desire to affect.

We have to consider the effects of :

Static electricity.  
Galvanic currents.  
Faradic currents.  
Alternating currents.

### Static Electricity.

But little is known about the physiological effects of this form of electricity. Suppose a patient placed upon an insulating stool, and connected with one of the poles of a working Wimshurst machine, he will become charged with electricity of high potential—10,000 to 100,000 volts, which will gradually escape from him through the air ; a current of very small amount, perhaps about the  $\frac{1}{10000}$  of an ampère, is passing through him. So long as he is not approached by a conductor, the only sensation he will experience will be a curious cutaneous one which has been compared to the touch of a cobweb ; if the charge be a strong one, some of his hairs will stand upright. Should a metal point be brought near him, a current or spray of air will be felt opposite to it. If a metal ball be substituted sparks will be drawn (even through the thickest parts of his clothing) ; these cause a burning and tingling sensation, and if strong will produce muscular contractions. These effects are more marked when the patient is charged negatively than they are when he is charged positively. The negative charge is the more irritating and stimulating. The electrical breeze (*souffle*) is more stimulating than the insulated static charge (*bain statique*), but is surpassed by the sparks. To obtain the strongest breeze the patient should be charged positively and the pointed electrode should be connected to earth or to the negative pole.

We have at last something more substantial and scientific to go upon than the ordinary vague statements of patients and partisans, for from a number of careful



experiments M. D'Arsonval has recently made, on men and animals, he concludes that the static charge (*bain statique*) always slightly augments the respiratory blood changes (the measurements being made by the mercurial pump and spectroscope); and that in a séance of twenty minutes the respiratory capacity of the blood is increased from  $\frac{1}{8}$  to  $\frac{1}{6}$ . This has a bearing upon the value of static treatment in phthisis (see Electro-therapeutics, pp. 261 and 279). A course of static electricity will raise the arterial tension, and those patients whose blood pressure is low will, *cæteris paribus*, derive the most benefit. Further, the pulse becomes more frequent (even up to 20 per cent.) and more regular; the digestive functions are stimulated, the nervous system is calmed, and sleep is more readily obtained.

A working static machine always produces ozone, and some have attributed the trophic effects observed to this; on the other hand, it has been shown that in animals enclosed in chambers filled with electrified (ozonized) air, no stimulating or trophic effects are observed, but that, on the contrary, the respiratory changes are diminished by the presence of nitrous products (especially nitric acid), also formed by the electrical spark in traversing atmospheric air. Further, Larat and Gautier subjected phthisical, anæmic, and emphysematous patients to an atmosphere rich in such ozone without obtaining any improvement; on the contrary, the treatment increased their coughs at first.

## CHAPTER II

### GALVANIC ELECTRICITY

IF the electrodes of a galvanic battery be laid upon a prepared muscle (gastrocnemius of a frog), and the circuit be closed and then opened, it is found that the muscle contracts both at the closing and opening, but that it also remains contracted during the flow. The latter is termed the galvanotonic contraction.

Place the electrodes upon the motor nerve, and close and open. The muscle will now contract at the closing and opening, but will remain quiescent during the constant flow. The opening and closing contractions are therefore momentary. The muscle can, however, be made to contract during the constant flow if the current-strength be suddenly varied, because that would be equivalent to making or breaking a fresh current or part of the original one ; but if the current-strength be slowly varied, no contraction will occur.

The continued steady flow of a current through a muscle therefore stimulates it. The continued steady flow of a current through a motor nerve does not stimulate the muscle.

#### **Electrotonus.**

During the passage of such a current, however, the excitability of the nerve is modified. Near (both on the distal and proximal sides, extrapolar and interpolar areas) the positive electrode it undergoes a diminution—'anelectrotonus'; near the negative electrode it becomes in-

creased—‘katelectrotonus.’ This law holds good whatever form of stimulation be employed to test the excitability with. It is of great importance in these experiments to use a stimulus of absolutely uniform force; the discharge of a condenser of standard capacity seems to be the most suitable. D’Arsonval discharges the condenser into the primary of an induction coil (without a magnet), and uses the alternating current induced in the secondary as the stimulus. Polarization is thus completely avoided, together with the fatigue that results from it. Between the two electrodes there must be a point where the excitability is unaltered, the neutral point, and this is nearer the anode with a weak current, and near the kathode with a strong current; with a weak current the greater part of the interpolar area is rendered more excitable; with a strong current less excitable.

Further, the conducting power of the nerve is diminished in the anelectrotonic area, and may by sufficiently strong currents be completely suppressed (physiological section).

We have seen (by the contraction of the muscle) that the nerve is stimulated at both closing and opening. This stimulation occurs at the ‘kathode’ when the current is ‘closed,’ and at the ‘anode’ when the current is ‘opened.’ When the circuit is closed, katelectrotonus becomes established near the kathode, and anelectrotonus near the anode; but the nerve is stimulated at the kathode when the current is closed; hence we may suppose that the appearance of katelectrotonus (increased excitability) acts as a stimulus.

The nerve is also stimulated at opening, but at the anode; hence we may suppose that it is the disappearance of anelectrotonus (diminished excitability) that acts as the stimulus. Further, the stimulation obtained at the kathode on closing is more powerful than that obtained at the anode on opening—*i.e.*, the appearance of katelectrotonus is a stronger stimulus than the disappearance of anelectrotonus. These laws have been established by Pflüger.

We see, then, that the nerve tissue is stimulated when it is made more excitable—that is to say, when either katelectrotonus is established or anelectrotonus is removed.

It was mentioned that one effect of the current was to diminish, or even suppress, the physiological conductivity of the nerve around the positive pole. A consequence of this is that with currents sufficiently strong the kathodal closing excitation may not be able to reach the muscle, if the anode lie between them, and we may be able to obtain a better contraction with a weak current than with a strong one.

The phenomena of electrotonus have been ascribed to the polarization which a constant current produces. Acids are liberated at the anode and alkalies at the kathode, between the axis cylinder and the white substance of Schwann (myelin). The phenomena are much less marked in nerves that have no myelin.

Do the same laws hold for the percutaneous galvanization of the human body? The following experiment will best answer this question.

With a milliampère meter, a current reverser, and interrupter in circuit, place a large electrode, the positive one, or anode, on a neutral spot such as the sternum, and a small button electrode, the kathode, on a superficial nerve such as the ulnar at the elbow, having first thoroughly moistened the skin. Throw several cells slowly into circuit: no contraction will be obtained. Now open and close: a contraction will probably be obtained at closing; if not, slowly increase the strength of the current by throwing in more cells, opening and closing between each accession of strength. It will be found if the tissues are healthy that a contraction will first be obtained on closing, a momentary contraction that does not persist during the steady flow of the current.

Diminish the current-strength, watching the milliampère meter until this closing kathodic contraction is only just visible. Now reverse the current so as to make the peripheral electrode the anode, and open and close

again : no contraction will follow. We are, therefore, justified in saying that a kathodal closing contraction can, *cæteris paribus*, be obtained with a weaker current than can an anodal opening or closing one. Keeping the anode over the ulnar, gradually increase the strength of the current, repeatedly opening and closing, until a contraction is obtained ; this may occur either when the current is opened or closed. Again reverse the current and close, and a stronger contraction will follow. Hence with the same strength of current the kathodal closing contraction is stronger than the anodal opening or closing one.

With the kathode still in position, increase the strength of the current, regularly opening and closing, until a contraction on opening is also obtained. A far stronger current will be required for this, and the pain experienced may prevent its being reached. It will be found, further, as the current-strength increases, that the muscles tend to remain permanently contracted during the flow ; this occurs first with the kathode over the nerve.

The law of stimulation of healthy human nerves is, therefore, as follows :

No muscular contraction is caused by the steady flow of a current (of moderate strength), or by the slow increase or decrease of such a current.

Muscular contraction is obtained most easily (with the weakest current) when the circuit is closed with the kathode over the nerve ; a stronger current is required to yield a contraction (and this may be either at opening or closing, or at both) when the anode is in this position ; and a still stronger one to give a contraction at opening with the kathode.

The contractions all increase at first in amplitude directly with the strength of the current, so that when the anodal contraction is obtained, the kathodal closing contraction is greater than it was at first, to grow still more, if the current-strength be pushed sufficiently to give a kathodic opening contraction ; but the muscles may at this stage have passed into a permanently contracted

state. The order in which these contractions occur is commonly tabulated in the following way :

- Weak current, 1 to 3 m.a., K.C.C. ;
- Stronger current, 3 to 15 m.a., K.C.C., A.C.C., A.O.C. ;
- Stronger current, 10 to 25 m.a., K.C.C., A.C.C., A.O.C., K.O.C. ;

where K. stands for kathodal, A. for anodal, C.C. for closing contraction, and O.C. for opening contraction. The dashes indicate the strength of the contractions.

Compare these results with the physiologist's. He obtains K.C.C. and A.O.C., while we obtain A.C.C. and K.O.C. in addition, K.C.C. being, under both conditions, the strongest stimulus.

The reason for this is doubtless to be found in the different conditions under which the experiments are conducted. If a nerve be excised and isolated, the whole current must go through it, the point at which the current enters it becoming its positive, and the point at which it leaves it becoming its negative, the former passing into an anelectrotonic state, and the latter into a katelectrotonic state.

A very different condition prevails in the human body. We are, in the first place, quite unable to tell what proportion of our current is passing through the nerve ; and, secondly, the polar effects are much more complicated. When the current has passed through the skin, it will, *cæteris paribus*, according to Ohm's law, seek the shortest path between the two electrodes, choosing for its conveyance, and according to the law of shunts (p. 87), those tissues which are the best conductors (offer the least resistance), and, as the resistance of a conductor depends both upon the specific resistance and upon the area of cross-section, it will naturally flow mainly through the muscles ; for these have both less specific resistance than the nerves and bone, and are comparatively very much larger in area of cross-section. But a very small amount of current, if any, will therefore flow along the nerve, the larger part, if

the nerve be close to the surface, and immediately beneath the electrode, leaving it almost at once to diffuse itself through the surrounding better conductors.

But we have seen that the point at which a current enters a conductor is the anode of the conductor, and the point at which it leaves the kathode; the nerve, therefore, has both an anodal and a kathodal area in immediate proximity to one another (Figs. 95 and 96), and should the other electrode be also placed over the nerve, there will be also two virtual electrodes applied to it, and hence the nerve will possess four virtual electrodes instead of the two in the physiological experiment. (De Watteville, 'Med. Elect.,' p. 107.)

Take the first case only, and suppose the anode to be applied directly over a superficial nerve, and the kathode over the sternum; then the current, entering the nerve beneath the electrode, will produce an anelectrotonic area there, and, leaving it on the other side distant from the electrode, will set up a katelectrotonic area there. The two areas of the physiologist are thus present, and in close proximity to one another; but the physiologist obtains a contraction at closing at the kathode, and at opening at the anode, respectively. But we also obtain contractions at opening and closing, no matter which electrode we may be using, because we virtually have both electrodes applied in close proximity to each other to the one nerve. Suppose we close with the anode in position, then the side of the nerve nearest to us becomes anelectrotonic, which does not stimulate; but the other side becomes katelectrotonic, which does stimulate; hence we obtain a contraction, which we term A.C.C.

If we open, then the area of the nerve farthest from the electrode returns to normal excitability (disappearance of katelectrotonus), which does not stimulate; but the area nearest to the electrode, which was anelectrotonic (in a condition of lessened excitability), now returns to normal. That is to say, we have a disappearance of anelectrotonus, which does stimulate. Similarly, with the kathode in

position, katelectrotonus becomes established on closing on the near side, and anelectrotonus on the far side, of the nerve; hence a contraction occurs from the appearance

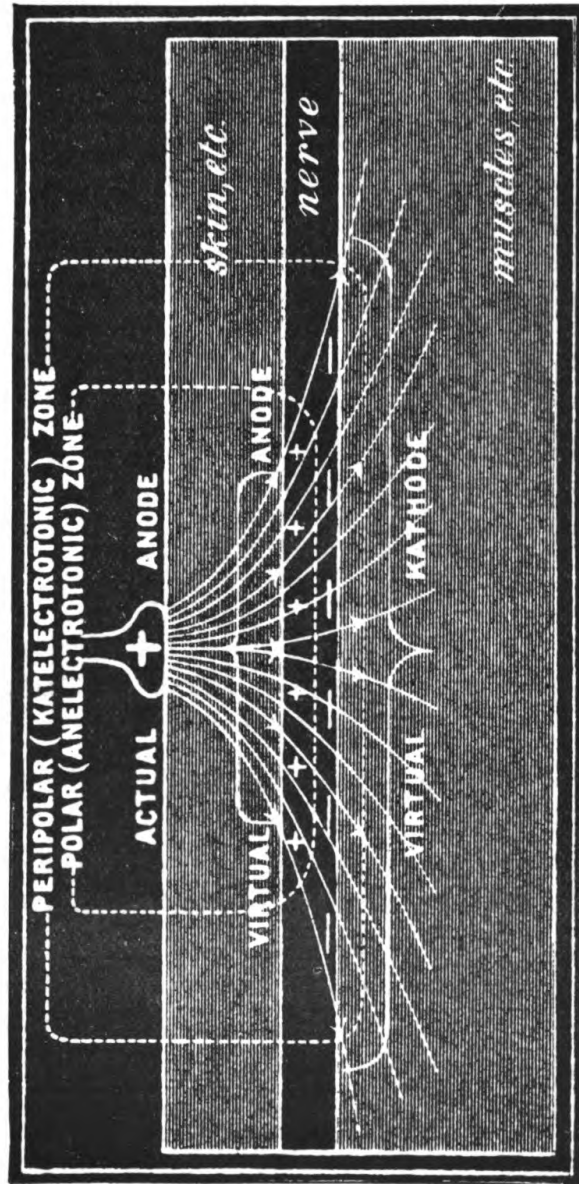

FIG. 95.—POLAR AND PERIPOLAR ZONES (De Watteville).

of katelectrotonus. On opening, katelectrotonus disappears on one side and anelectrotonus on the other; and the disappearance of anelectrotonus is the stimulus.

II



Further, as the effect of the current depends largely upon its concentration or density, and as this must, *cæteris paribus*, be greatest on the side nearest the electrode, the establishment of katelectrotonus on that side of the nerve will be a stronger stimulus than the establishment of kat-electrotonus on the other side—*i.e.*, K.C.C. will always appear before A.C.C., and K.C.C. will also appear before A.O.C., because it is physiologically the stronger stimulus.

This (electrotonic) explanation of the laws of contraction is the one generally accepted in Germany, Great Britain, and America, though not in France. Waller and De Watteville, by a series of elaborate and careful experi-

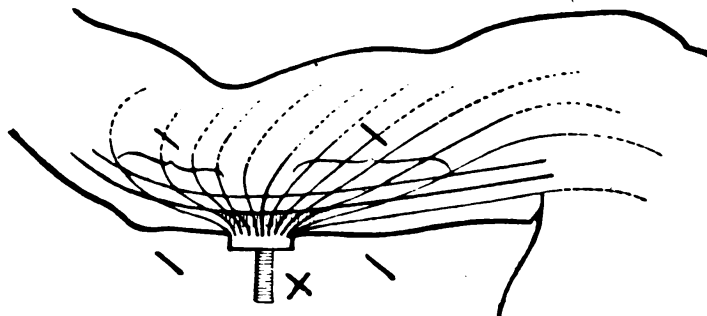

FIG. 96.—ANODAL AND KATHODAL AREAS ON ULNAR NERVE (De Watteville).

ments, have demonstrated the leading facts of electrotonus in the human body.

It has already been remarked that the degree of stimulation obtained varies with the current-strength. This is only partially true. Chauveau has shown, using curves to indicate his results, that, with closing shocks, the amount of stimulation obtained with the kathode at first grows with the strength of the current, then remains stationary, and may sometimes decrease; the degree of stimulation obtained with the anode, however, regularly increases with the current, and therefore overtakes and surpasses that obtained with the kathode. There is, then, a neutral point, where both kathode and anode equally stimulate. With opening shocks the results are the reverse. The anodal opening is the first to appear, and the

degree of current-strength necessary to equalize the kathodal and anodal closing stimulations is usually the signal of its appearance.

These laws hold for both men and animals.

### The Striped Muscles.

Turning now to the voluntary muscles, we find that we obtain by direct stimulation of them analogous contractions to those obtained by stimulation of the nerve; thus, K.C.C. is the first to appear, and the opening contraction is anodal. It is probable that the muscles are stimulated through their intramuscular nerve supply (*vide* 'Motor Points').

### The Unstriated Muscles.

The involuntary muscles obey the same laws, but are more sluggish in reacting, and do not at once relax after the cessation of the current; requiring a stimulus of long duration, they react more readily to galvanism than to faradism. This is of importance in the treatment of constipation. According to Beard and Rockwell ('Med. Elect.', p. 162), the anode is the stronger stimulus; if this be the case, their reactions would appear to be somewhat analogous to those of degenerated voluntary muscles (*vide* 'R. D.', p. 215).

### Sensory Nerves.

The polar reactions of the sensory nerves seem to be in harmony with those of the motor nerves; the kathode is the strongest stimulus at closing, and the anode at opening; but as the sensations experienced are of a mixed and continuous character if the current be strong, and due to various causes (the actions of the acids and alkalies liberated at the poles being the most important), some confusion still exists. It is stated that with weak currents the anode is the stronger stimulus, with larger currents the kathode.

### Nerves of Special Sense.

The reactions of the nerves of special sense yield interesting results. They respond better to stimuli of some duration, and therefore better to galvanism than to faradism. This response consists in a manifestation of their specific sensation ; the optic nerve responds with a sensation of white or coloured light, the auditory nerve with one of sound, etc.

The ' optic ' nerve is exceedingly easily stimulated ; the interruptions of a galvanic current anywhere in its neighbourhood are sufficient.

If one pole be lightly pressed upon the closed eyelid, and the other be upon the sternum, or nape of the neck, the interruptions of a very weak current (1 to 3 m.a.) will stimulate it, and it will be found to react to both kathodic and anodic makes and breaks. Attempts have been made to classify the light and colour sensations obtained ; thus it is said that K.C. and A.O. produce for one individual the same sensations, and that these differ from those obtained at K.O. and A.C. : the latter also produce identical sensations. If an individual experience a sensation of a reddish light with K.C., he will experience the same with A.O., but some other with K.O. and A.C.

An analogy can thus be drawn between these results and those obtained with the motor nerves, which suggests that the former also depend upon the actual or virtual position of the exciting electrode.

The ' auditory ' nerve may be stimulated either by filling one ear with tepid water, and dipping a suitable wire electrode into it, with the head inclined to one side and resting on a cushion, or the exciting electrode may be placed just in front of the ear : the indifferent electrode may be on the nape of the neck. It will react only to K.C. and A.O., and the nature of the sound produced varies with the individual ; it may be of a buzzing, humming, or whistling character. K.C. is, as usual, the strongest stimulus, and the sound produced may persist

for some little time. Owing to the giddiness produced by the application of the current to the side of the head, the reactions are difficult to obtain. The complete formula of the auditory nerve therefore is :

K.C.	-	-	-	Loud sound.
K.D.	-	-	-	Sound persists for a time.
K.O.	-	-	-	No sound.
A.C.	-	-	-	" "
A.D.	-	-	-	" "
A.O.	-	-	-	Short weak sound.

The 'gustatory' nerve, like the optic, is easily stimulated. Place the electrodes on either cheek, and pass a moderate current ; the sensation on the side of the anode will be the stronger, and of a metallic nature. On the cathodic side the sensation is feebler, and of a saltish nature. The sensations persist during the passage of the current.

### The Brain.

The sensations produced by the passage of a current through the head vary with the position of the electrodes.

Let the inactive large electrode (K) be upon the abdomen, and the active one upon the forehead. Pass a current of about 5 m.a. Two sensations will be felt—a burning and tingling one beneath the electrode, and a dull heavy ache about the vertex ; move the electrode slowly in the longitudinal direction over the vertex, occiput, and down to the cervical region. Little or no giddiness will be felt in any situation, and the current can be raised in strength (to about 10 m.a.) after leaving the forehead. The dull pain will continue until the occiput is reached. As the electrode leaves the occiput, a swallowing motion will be induced, and the galvanic taste felt.

Now place the electrode over the mastoid process ; giddiness, with a tendency to fall to one side, is at once experienced. The falling sensation, if both electrodes be on the mastoid processes, is from the kathode on closing, and towards it on opening. Great care should be taken not to interrupt without due precautions galvanic current s

applied to the head, for if this be incautiously done, the unpleasant sensations become greatly intensified.

It will have been noticed that galvanic currents, as a rule, only stimulate at opening and closing, and at sudden increases and decreases in the current-strength; that is to say, the tissues are especially excited by changes in the potential. This is best exemplified by the motor nerves, which in this respect resemble the secondary wire of an induction coil. Thus both are excited at closing and opening, and at variations in the potential, but remain quiescent during the steady flow; moreover, within certain limits the more suddenly the changes in potential are brought about, the greater is in both cases the degree of excitement induced. The elements to be considered in an electrical stimulus are :

- (a) The current-strength.
- (b) The difference of potential.
- (c) The duration.

The nerves appear to be excited principally by the rapidity and the amount of the variation of potential; the muscles by stimuli of longer duration and greater current-strength.

## CHAPTER III

### ELECTROLYSIS

WE have already seen that when a continuous direct current is passed through an electrolyte the latter is decomposed. What constitutes an electrolyte? Is the human body one?

An electrolyte is a compound substance which conducts electricity by virtue of simultaneous chemical decomposition. A metallic conductor undergoes no chemical decomposition or visible change during the passage of a current; it may be heated, but that is all. Whether it is ever possible for an electrolyte to conduct without undergoing decomposition is a question that is not yet settled. The process of electrolysis may be contrasted with the action that goes on in a galvanic cell; in the latter we obtain an electrical current by chemical combinations; in the former we produce chemical decomposition and separation by means of an electrical current. Yet the two run into each other, for in the galvanic cell we also have electrolysis and the liberation of gases, and in the electrolysis vessel the separation of the ions leads to a polarization current.

The chief electrolytes are aqueous solutions of salts, acids, and bases. When a current passes through an electrolyte, the particles of which the solution is composed (which are believed to be already in more or less of a dissociated condition and to carry electric charges—electrons) are driven in opposite directions; some move to the positive pole (anode), and some to the negative pole (kathode).

The anode is the pole by which the current enters, and the kathode is the pole by which it leaves. The moving particles are called the 'ions,' and those which go to the anode are the 'anions,' and those which go to the kathode are the 'kations.'

The anions are also termed electro-negative, because they appear to be attracted to the positive pole, and the kations are for a like reason termed electro-positive. The acid radicals or elements, such as oxygen, sulphur, chlorine, bromine, iodine, and sulphur, move from the kathode to the anode, and are not liberated until they reach the surface of the electrode. They constitute the anions. The hydrogen of the acids, and the metals and metallic radicals of the salts and bases, *e.g.*, potassium, sodium, zinc, and copper, move from the anode to the kathode, and appear only at the negative electrode. They are the kations. Oxygen is the most electro-negative, and cæsium, rubidium, and potassium the most electro-positive. The same ion may at one time figure as an anion, and at another as a kation, according to the polarity of the ion to which it may be united.

The following is a list of the commoner elementary substances arranged in an electro-chemical series.

*Electro-negative.*

Oxygen.  
Fluorine.  
Sulphur.  
Nitrogen.  
Chlorine.  
Bromine.  
Iodine.  
Phosphorus.  
Arsenic.  
Carbon.  
Silicon.

*Electro-positive.*

Hydrogen.  
Gold.  
Platinum.  
Silver.  
Mercury.  
Copper.  
Iron.  
Zinc.  
Manganese.  
Magnesium.  
Calcium.  
Barium.  
Sodium.  
Potassium.  
Cæsium.

Each of these is electro-negative to the one following it, but electro-positive to the one preceding it.

Fig. 97 is a diagram of a galvanic and of an electrolytic cell to represent the relation of the poles to each other. The wire which starts from the positive pole (copper) of the galvanic cell is attached to the anode of the electrolytic cell, and the kathode of the latter is attached to the negative pole or zinc of the galvanic cell. In the electrolysis of acidulated water with platinum electrodes the oxygen atoms, being charged with negative electricity,

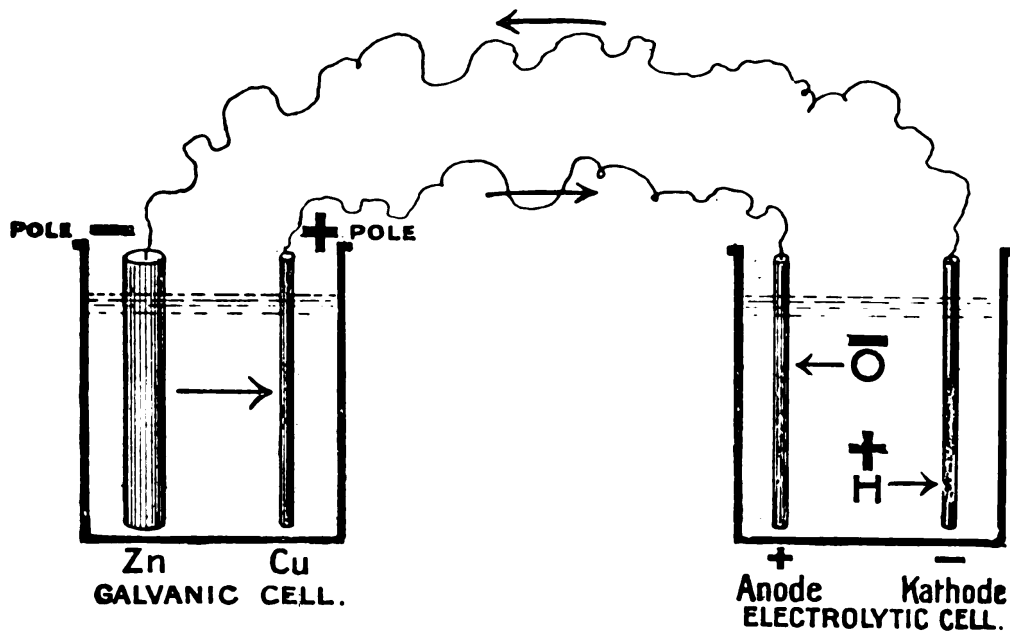

FIG. 97.—GALVANIC CELL COUPLED TO ELECTROLYTIC CELL.

are attracted to the positively charged anode, while the hydrogen atoms, being charged positively, are attracted to the negatively charged kathode; hence the hydrogen always goes down, or in the direction of the current. Faraday's three laws of electrolysis may be stated as follows:

1. The electrolytic action of a current is equal at all points of a circuit.
2. The amount of gas liberated in a given time is proportional to the average current-strength during that



time (thus 2 ampères will liberate twice as much gas as 1 ampère).

3. When the same current acts on many electrolytes, the weights of the elements separated by electrolysis are in proportion to the chemical equivalents of these elements.

The chemical equivalent of an element is obtained by dividing its atomic weight by its valency. Thus, if we divide the atomic weight (16) of oxygen by its valency (2), we obtain its chemical equivalent (8). In studying the effect of the passage of a current through the tissues these laws are of importance.

Fig. 98 is that of the arrangement for obtaining the two gases separately. There is twice as much gas in

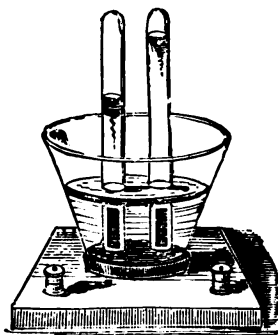

FIG. 98.—ELECTROLYSIS APPARATUS.

the one tube as in the other, because two volumes of hydrogen are liberated for one of oxygen ( $H_2O$ ); owing, however, to the oxygen being more soluble in water than the hydrogen, and to its containing a small amount of ozone, the proportion is not quite accurate. If sodium chloride be the solution, the sodium will pass to the kathode, and the chlorine to the anode.

Put generally, we obtain oxygen and acids at the anode, and hydrogen and alkalies at the kathode. Between the electrodes no change except a difference in the concentration of the solution can be detected. In explanation of this phenomenon the following theory, first propounded by Grotthuss, and modified by Clausius, is the one usually accepted.

### Theory of Grotthuss and Clausius.

The greater number of the particles in an electrolyte exist in a dissociated condition ; they exist as ions, and are, before the current is passed, arranged and moving about in every conceivable manner (Fig. 99). When a current is passed they become arranged in definite order, the anions being directed towards the positive pole, and the kations towards the negative pole (Fig. 99). Suppose we are dealing with dilute sulphuric acid : the current turns the hydrogen towards the kathode, and the sulphion towards the anode ; these then commence to migrate to

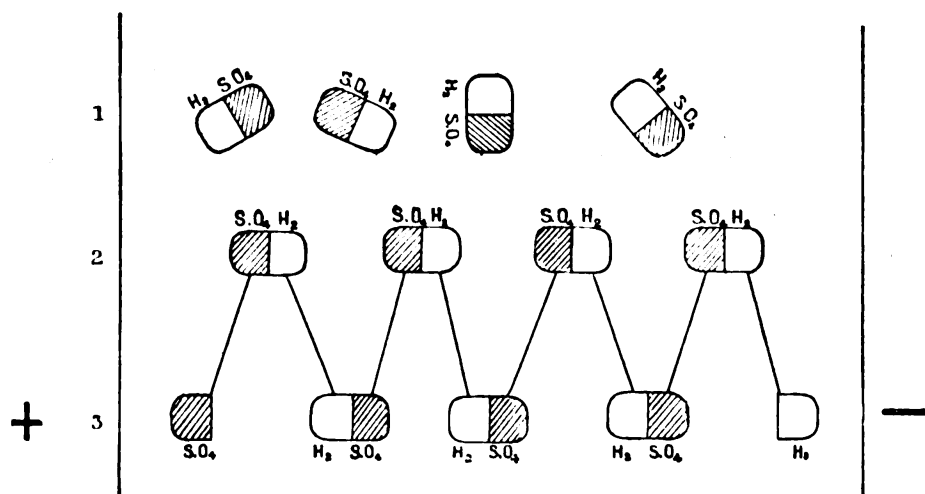

FIG. 99.—THEORY OF ELECTROLYSIS.

In the first row the molecules are indefinitely arranged ; in the second they are arranged in proper order to migrate ; in the third they have migrated, and are recombining, except at the electrodes, where they are free.

their respective poles, but the molecule sulphion, immediately meeting with a molecule of hydrogen, which is migrating in the opposite direction, recombines with it, and in a corresponding way an interchange of partners goes on all along the line (Fig. 99), but the molecules nearest to the electrodes, finding no partner to combine with, are set free. The dissociated and wandering ions are supposed to be seized by the entering current, to be

utilized as a means of transport through the solution. If this be so, it follows that the more dissociated the ions in any solution may be, the more easily will the current be able to get through ; that is to say, the conductivity of an electrolyte may be supposed to depend mainly upon the number of dissociated ions that may be present in it. This is, speaking generally, the case. (Bleekrode does not accept this view.) The electrolytes, whose constituents are for the greater part dissociated into ions, are those that possess the greatest chemical activity, and it is precisely these that have the greatest conductivity (*vide* table of resistances, p. 61). Thus nitric acid conducts better than sulphuric acid, and both these better than a solution of sulphate of copper.

This theory is supported by the effect of raising the temperature. The conductivity of an electrolyte is increased by heating it, but the latter process causes the molecules to become more dissociated. We may therefore conjecture that the greater conductivity depends upon the greater dissociation.

If it be granted that the chemical activity of an electrolyte depends upon the number of dissociated particles which it contains, and that these can be measured by its electrical conductivity, we have a rapid means of estimating the chemical activity, and therefore the constitution, of an electrolytic solution. This subject will be reverted to in the chapter on Electro-Diagnosis.

A convenient method for testing the condition of a bichromate solution is to measure its resistance. The specific resistance of the chromic acid solution at 60° Fahr., described on p. 40, is from 1.7 to 2 ohms when fresh. This will steadily increase as the solution is used, till its complete exhaustion, when the specific resistance will be about 30 ohms ; not much current can, however, be obtained when the resistance has once passed 12 ohms, and the solution should then be changed.

### Secondary Electrolysis.

When the ions are set free at their respective poles, as in the case of the hydrogen of the dilute sulphuric acid, we have what is termed 'primary electrolysis.' If, however, the ions, which are liberated at the poles, can combine with the water, or with the material of the electrodes, they will do so, and will yield only the results of their combinations. This is called 'secondary electrolysis.' Thus, the sulphion in the last instance, when set free at the anode, combines with the water to form sulphuric acid, liberating oxygen; similarly, in the electrolysis of alkalies, taking sulphate of soda as an example, the sodium set free at the kathode at once decomposes the water, liberating hydrogen and forming caustic soda solution, while at the anode we obtain, as before, oxygen and sulphuric acid.

The human body, consisting of various tissues bathed with an alkaline medium, must undoubtedly be regarded as an electrolyte; it can only conduct electricity by virtue of moving ions and chemical changes, and the effect of passing the smallest galvanic current through it is *pro tanto* to decompose it.

Pass a current, using bare metallic electrodes, through the arm; beneath and around the plates there may be at first a temporary pallor, but this is soon replaced by a deepening and long-persisting hyperæmia: papules and vesicles follow, at the kathode filled with an alkaline fluid, at the anode with an acid one, and the latter, unless made of platinum, will be tarnished by oxidation.

If the electrode be well padded these effects are much less marked, and stronger currents can be borne.

The tissues are so complex in their structure that it is quite impossible to say what decompositions and recombinations may go on. Suppose potassium set free at the kathode, it will decompose the water with which the skin has been moistened to form caustic potash, setting hydrogen free. The latter may either stick to the electrode, enter into some new combination, or escape. The former

will combine with the fatty matter of the tissues, and produce the ordinary effect of the application of a caustic alkali, but to a greater degree, in consequence of its nascent condition.

Suppose the blood in an aneurism be electrolyzed with both needles introduced, coagulation is produced at each pole. Around the anode the clot is firm, small, and of an acid reaction; around the kathode it is looser, larger, frothy, and of an alkaline reaction. Oxygen, chlorine, acid-albumen and acids, with their secondary results, are liberated at the anodic needle; hydrogen (which forms the froth), the alkalies, alkali-albumen, metals (iron), and their secondary results, appear at the negative pole.

Dr. Stewart (*Lancet*, December 13, 1890) has observed that practically the whole of the conduction in animal tissues is electrolytic, and that the electrolytes are chiefly the inorganic constituents; the changes in the proteids are brought about by secondary electrolytic actions; he finds no indication that hæmoglobin acts the part of an ion.

If a piece of dead muscle be electrolyzed, the parts around the anode become hardened and dried, and cling to the needle, rendering its withdrawal more difficult than that of the cathodic needle. Around the latter there is much frothing, and the tissues appear to be softened and liquefied; the needle is quite loose.

A specimen of urine is easily electrolyzed; bubbles of gas appear at both poles. At the kathode they are small and very numerous; at the anode they are larger and fewer. (Platinum electrodes should be used.) A white cloud or coagulum soon forms around the kathode, which falls, as it gets thicker, to the bottom in the form of a ring, another cloud being formed above it; the tube becomes in this way gradually filled with the coagulum. As the action goes on, the hydrogen bubbles collect above the kathode to form a froth, which, if the current be a strong one, may easily attain a length of a couple of inches. At the anode the action appears to be much less intense; the

most noticeable phenomenon is a peculiar brownish staining or coloration, which gradually increases in length ; it may, perhaps, be due to uric acid or its derivatives. Sometimes a faint or very delicate cloud is formed. In albuminous urines distinct clots intermingled with gas are common. On microscopical examination of drops taken from the neighbourhood of the electrodes and allowed to evaporate, irregularly-shaped crystals of various kinds can be seen ; amongst these are phosphates, particularly phosphate of lime, oxalates, cholesterin, deeply-stained urates (at the anode), etc.

In dropsical fluids a white cloud appears at both poles.

In all these actions the parts around the anode become very acid, and around the kathode highly alkaline, and the ions appear only at the surface of the electrodes. In the electrolysis of a complex substance like the human body, consisting of different tissues in close apposition, it is important to determine whether there is any interpolar action. Are the acids and alkalies only liberated at the metallic electrodes, or are they set free also in the tissues ? The following are some of the experiments that have been performed in relation to this subject ' out of the body ' on inorganic electrolytes. Faraday passed a current upwards through a strong solution of sulphate of magnesia into a layer of distilled water lying above it, and found that magnesia was deposited at the point of junction of the two liquids. Daniell performed some similar experiments on solutions of nitrates and sulphates separated from a dilute solution of caustic potash by a membrane, and observed that the ions were set free at the surfaces of the membrane. Dr. Gore has shown that every inequality of composition or of internal structure of the liquid in the path of the current must act to some extent as an electrode. Various experiments have also been performed on solutions contained in three glass vessels connected by moistened lamp-wicks. Dr. Golding Bird has stated that, if the first and third vessels are filled with solutions of barium chloride, and the centre one with

sulphuric acid, the passage of the current will cause a white precipitate in the second vessel, because the barium in traversing the second vessel forms an insoluble compound with the acid. U tubes will be found convenient for such experiments (Fig. 100).

Dr. Steavenson repeated this experiment, but without success ; and, though several times attempted, it has also failed in my hands. A white precipitate of barium sulphate rapidly appears at the positive pole, showing that the  $\text{SO}_4$  has passed over, but it appears 'at the electrode,' so that the  $\text{SO}_4$  must have traversed the barium chloride solution in the U tube connected to the positive pole without forming a stable compound with it. Some green colouring matter went along with the current from the positive toward the negative pole.

This question, for a long time discussed, and of late brought more prominently forward by the therapeutical results obtained by Apostoli, seems now to be in a fair way of being settled by some experiments performed by M. Weiss. He observed that the contractions obtained by the galvanic stimulation of a frog's muscle regularly decreased in amplitude so long as the current was maintained in one direction, but that they could be restored to their original vigour by reversing the direction. Were the diminution in the amplitude of the contractions due merely to fatigue, rest should suffice to restore them ; but this it does not do. These facts support the view that, during the passage of a current, chemical changes occur in the interior of the muscle ; that these are of the nature of polarization changes, which are increased by the passage of the original current, and which can be swept away and nullified by a reversal of the current.

Let a current of 2 or 3 milliampères be passed for a few minutes through the leg muscles of a healthy uninjured frog. A week later examine the contractions of these muscles, and they will be found to have lost a great part of their excitability, not only for currents in the same direction as the previous one, but also for those

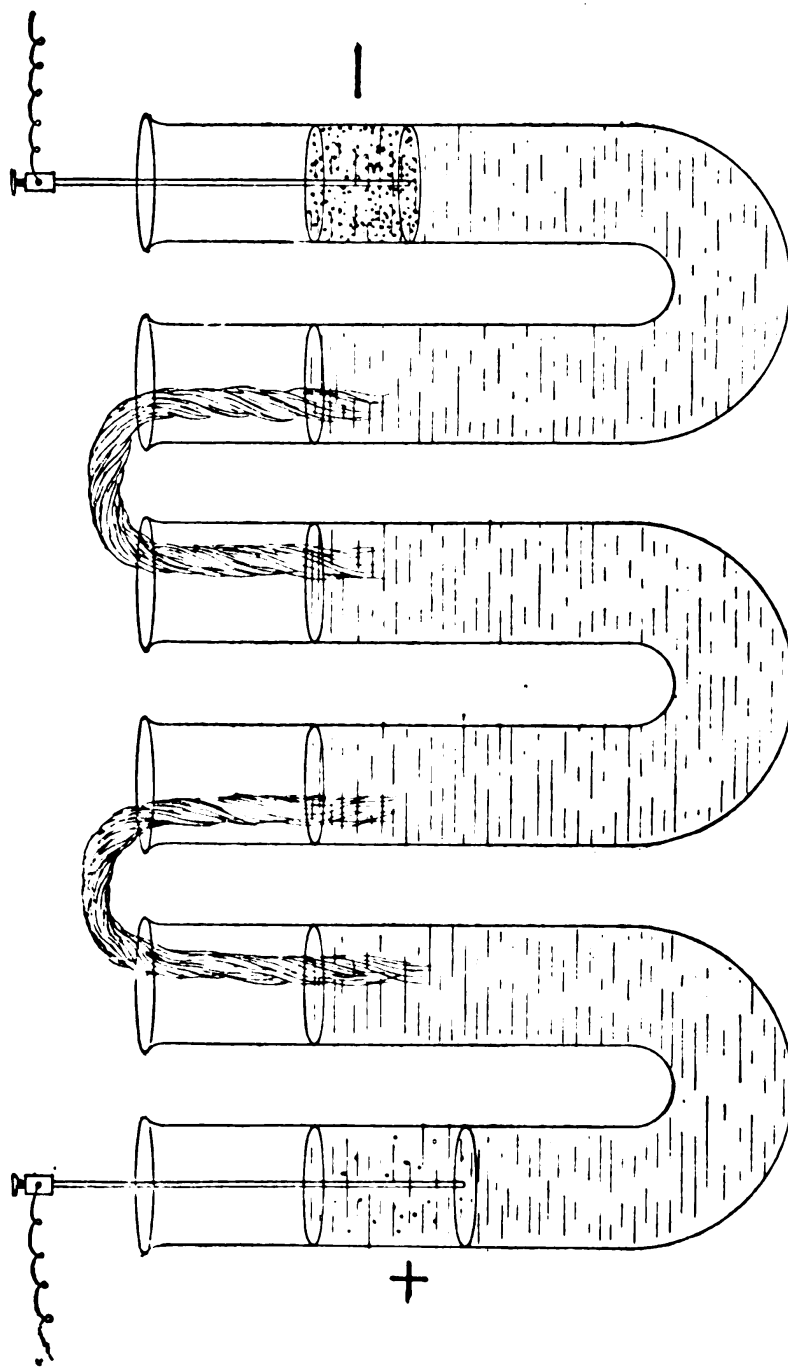

FIG. 100.—U TUBES FOR EXPERIMENTS ON INTERPOLAR ACTION



in the opposite direction. The muscles of the leg which was not electrolyzed will contract very much better.

But the microscope can also be used. Submit a frog two or three times to a continuous current, and then permit it to live; a month later examine its muscles: they will be found to exhibit marked microscopical changes. M. Weiss has found that a single five minutes' séance with a current-strength of 1 to 2 milliampères so alters the muscular structure that evidences of it can be seen for several days afterwards. (Weiss, 'Electro-physiologie,' p. 127.)

It may fairly be held to be probable that the strong currents (200 m.a.) passed by Apostoli through uterine fibroids exercise the same effect, and that their diminution in size is at any rate partly due to the retrogressive and disintegrating changes set up in them by interpolar chemical changes. Evidence of the electrolytic action of a continuous current upon the tissues is to be found in the circumstance that the body will act as a secondary battery and yield a current, if it has already had one passed through it. Holding the electrodes from a battery in the hands, let a strong current pass for a few minutes; now let go the electrodes, wipe them, and place the hands into two vessels of salt water connected with the terminals of a galvanometer; the needle will indicate the existence of a current in the reverse direction to the original one.

By passing a galvanic current through the body we therefore decompose it, the products of the decomposition appearing at the places where the current enters and leaves the body, and probably at various intermediate places also. These products consist at the anode of acids and oxygen, and at the kathode of alkalies and hydrogen, and being in a nascent condition they have a more powerful effect than they would ordinarily have. Further, they act and react on the tissues and electrodes to form secondary and tertiary compounds.

### Cataphoric Effect.

Porret, Becquerel, Van Bruns, Munk, and others have investigated this subject. If two liquids of different densities be separated by a porous partition, osmosis will occur, and the fluid of less density will slowly pass through to the fluid of greater density. If, however, the two electrodes of a battery be placed respectively in the two compartments, the fluid will usually pass from the anodic to the cathodic side, no matter what the densities may be. Poor conductors, as a rule, are more easily conveyed than either good conductors or non-conductors. This mechanical transference of fluid is termed cataphoresis.

It may be easily tried with a porous pot and a glass jar, or simply with a U tube, into the bend of which a little fine sand should be run to form a partition. On placing the electrodes in the two arms and closing the circuit, the level of the solution on the cathodic side will slowly rise a little above that on the anodic side in opposition to gravity. M. Weiss has performed some interesting experiments in connection with this subject. A U tube is filled with gelatine, which is allowed to solidify; it is then inverted over two vessels in such a fashion as to connect the fluids within the vessels. The fluids may be coloured with eosine, methylene blue, etc.

If a current be passed, the colouring matter will ascend considerably higher in the one arm of the U tube than in the other, and the direction in which this will occur seems to depend upon the nature of the colouring matter. Methylene blue passes from the anode to the cathode, eosine from the cathode towards the anode.

It is possible to pass by cataphoresis various medicinal substances through the unbroken skin. Iodide of potassium, strychnine, atropia, quinine, bichloride of mercury in solution, have thus been introduced, and their presence recognised by testing the urine and saliva, or by their physiological effects. A profound local anæsthesia may thus be induced by the introduction of a 10 per cent.

solution of cocaine. Gouty deposits (p. 294, 304) may be attacked by alkalies, and glandular swellings and chronic effusions by iodine. Were it possible to conduct the medicament some little distance into the tissues, a more extended application of this property might be made (a phthysical cavity could thus be directly treated), but owing to the diminution in the current density, so soon as the moistened portion of the skin beneath the electrode has been passed, it is not probable that the medicament can be made to go much farther than the subcutaneous tissue, where it becomes absorbed by the blood and lymphatic vessels. It is a further objection that strong currents and extended séances are required. Special electrodes with cups or cavities covered with cloth to hold the medicament can be purchased, or the part may be immersed in a bath of the solution. Not much result may be expected with a current of less than 50 m.a., unless long-continued applications are made.

#### Trophic Effects of the Constant Current.

It might be supposed that an agent capable of influencing the tissues in such various ways, and of producing polar and interpolar decomposition with hyperæmia of the parts to which the electrodes are applied, would be capable of profoundly modifying nutrition. The authorities on electrotherapeutics have, as a rule, accepted this view, and have included much else that is vague or obscure under the common term of *catalysis*. Therapeutical records, and the testimony of experienced observers, have all borne witness to this trophic action in disease. M. d'Arsonval, in a recent series of experiments (examining the absorption of oxygen, the elimination of CO<sub>2</sub>, the respiratory capacity of the blood, the amount of urea, and the heat changes, etc.) on healthy men and animals, found, however, to his great astonishment, that the constant current exercised no immediate trophic or nutrition-encouraging action whatever. (*Bulletin de l'Académie de Médecine*, March 22, 1892.)

A more prolonged series of such scientific experiments is required; meantime, statements as to the 'trophic' action of the constant current should be received with caution.

### Bactericidal Action.

The constant current has been credited by Cohn and others with this action. Drs. Apostoli and Laquerrière, who have recently conducted a long series of experiments in this direction, principally upon the *Bacillus anthracis*, have come to the following interesting conclusions:

1. In a homogeneous medium a constant galvanic current has no peculiar action *sui generis* upon cultivations of bacteria.

2. Whatever action it seems to have is due either to heating or to chemical effects.

3. If the heating effects be prevented, or the electrodes be at some distance apart, then the only position at which any definite action can be observed is at the anode.

4. Under these conditions no action seems to occur either at the kathode or in the rest of the circuit.

5. This anodal action is purely chemical or electrolytic, and is especially connected with the nascent oxygen liberated, for if this be absorbed by appropriate means all bactericidal action there is lost.

6. The action increases with the current-strength (after a certain minimum of about 50 m.a. has been passed) and with the duration of the application.

7. A current of a strength below 50 m.a. can restore virulence to an attenuated culture, and thus act as a re-vivifying agent. Thus animals inoculated with the solution before the current is passed do not die, while those which are inoculated after the current has been passed do die. (*Revue d'Electrothérapie*, August, 1891.)

## CHAPTER IV

### FARADISM

WE need now consider only the physiological effects, for electrolysis and cataphoresis are practically unobtainable by faradic currents. If a motor nerve be faradized by the secondary current of an ordinary induction coil, muscular contractions will occur, and will persist throughout the period of the flow. This is because the stimuli succeed each other so rapidly that the muscle has not time to relax between their successive arrivals. The stimuli become accumulated, and the successive muscular contractions fused; the muscle is said to be tetanized. The more rapidly the stimuli arrive, the less easy will it be to note the individual contraction; and *vice versâ*, the longer the interval between the stimuli, the more distinct do the contractions become. It is said that nineteen and a half stimuli must arrive per second to make simple contractions compound; when this point has been passed, the contractions become more marked as the number of the stimuli increase. There is, however, a limit to this, as we shall see in discussing the physiological effects of M. Tesla's currents, but this limit cannot be reached by the ordinary medical induction coil.

As we have already seen (p. 114), it is the opening induction current that is the strongest, and accordingly the opening muscular contraction is also the strongest. Further, the kathode is a stronger stimulus than the anode. The same laws hold for percutaneous application. With a current reverser in the circuit, place one electrode

over the sternum, and the other (button-shaped) over the ulnar nerve at the elbow ; grasp Neef's hammer between the finger and thumb, and turn on the current ; move the hammer slowly up and down, so as to give single induction shocks ; the muscles will contract whenever the current is opened ; reverse the current from time to time : the kathode will be found to be the stronger stimulus of the two ; now release the hammer, and the muscles will become tetanized.

The voluntary and involuntary muscles can be directly stimulated in the same way, though, as already mentioned, for the latter a stimulus of longer duration is an advantage. (The faradic current probably stimulates the muscles through their nervous elements.) It is difficult to excite the nerves of special sense by either the primary or secondary faradic streams ; my attempts have been unsuccessful. The nerves of ordinary sensation are, on the other hand, very readily excited. Under these circumstances they give rise to the impression of a sort of burning and pricking, which grows, within certain limits, with the rapidity of the interruptions and the E. M. F. of the coil. Shocks from large coils with long, fine secondary wires are dangerous.

A strong faradic current is said to produce a benumbing effect on the sensory nerves (faradic anæsthesia). Dr. Aust - Lawrence and Dr. Newnham (*British Medical Journal*, November 28, 1891) have made successful use of this property in gynæcological cases. It has also been made use of for deadening the pain attending the extraction of teeth. The sudden shock of a faradic current applied to the root of a tooth might certainly serve to distract a patient's attention.

The physiological effects of the faradic current are to 'excite function' ; for the motor and sensory nerves it is at once the best and most convenient stimulus we possess. By this property it exercises the muscles, increases metabolism, helps nutrition, and produces a general tonic effect. It thus possesses a *trophic* action,

which is most marked when it is applied in the form of general faradization. Whether it can at all exercise this action *per se*, apart from the muscular contractions it sets up, is uncertain.

#### Bactericidal Action.

The induced current can, according to Spilker and Gottstein, exercise this action. As no electrolysis or chemical change can occur, and as heating effects were guarded against in their experiments, the action must be one *sui generis*, a specific one. To have effect the current must be kept up a considerable time (more than an hour), and strong currents seem necessary. (*Deutsche Med. Zeit.*, No. 3,891.)

#### Alternating Sinusoidal Currents.

No other form of electrization appears to yield such marked trophic effects as the sinusoidal currents of M. d'Arsonval's magneto-electric machine. By revolving it at a speed insufficient to stimulate either the muscles or nerves, he found he could instantly increase in both men and animals the respiratory gaseous exchanges by more than one quarter. (*Bulletin de l'Académie de Médecine*, March 22, 1892.) The peculiarity of the sinusoidal motor (see p. 122) is that it produces so smooth an alternating current (the passage from a current in one direction to that in an opposite direction is so gradually and equably effected) as to diminish greatly, if not annul, all sensible reactions. When the machine is slowly revolved, there is no reaction at all; a quick revolution produces a pricking sensation, but without the ordinary feeling of burning. At an increased speed an agreeable slight muscular contraction is produced, and the muscles become tetanized; this effect reaches its height at a frequency of 2,000 alternations per second; beyond this frequency the muscular contraction diminishes, and disappears altogether at a frequency of about 10,000. The

sensations which accompany the muscular contractions are much less painful than those produced by using an induction coil. For unstriped muscle the sinusoidal current is an excellent stimulant ; it is therefore of service in energizing the bowel and uterus ; it will also relieve the obscure pains associated with uterine affections. Chronic congestions tend to be dissipated, and diuresis is increased. By far the best method of applying these currents is to make use of local or of general baths (p. 272) ; the strength of the current should be regulated by a sledge coil, and a sinusoidal milliampère meter should be used. The alternating current mains can, when transformed down, be used for the same purposes, for they are practically sinusoidal in character. It is another peculiarity of this current that it stimulates the optic nerve, producing a sort of mosaic of light and dark patches (*phosphènes*).



## PART III

### *ELECTRO-DIAGNOSIS*

#### CHAPTER I

### **ELECTRICAL RESISTANCE AND CAPACITY OF THE HUMAN BODY**

**Resistance of the Tissues** (*vide* also p. 61).—As already mentioned (p. 65), the only fairly correct method of estimating the resistance of the body is to employ alternating currents, a Wheatstone bridge and telephone (Kohlrausch's method). Even by this method approximate results only can be obtained, because it is very difficult to bring the telephone to absolute silence ; we have to be content with the position in which it is most silent. The use of a galvanometer, a constant E. M. F., and the application of Ohm's law, can only yield a very rough approximation, chiefly for two reasons.

1. The resistance varies with the duration of the application.

2. The resistance is affected by polarization of the body. Much, therefore, will depend upon the instant at which the observation is made ; thus we may measure the initial resistance (probably the most accurate) or any subsequent one at the end of a minute or three minutes, or the lowest resistance obtained with a fixed number of cells during a five minutes' application. Kohlrausch's method avoids these difficulties. The weak induction currents necessary for an observation do not diminish by their duration the

body resistance, and there can be no polarization. Strong alternating currents (from a dynamo) do diminish it. It would appear, further, from some recent researches of Dr. Stone and others, that the resistance of the body is diminished by a high E. M. F., and that it is consequently less for the faradic currents of a coil than it is for ordinary galvanic ones. Electrodes of the same size should always be used, and firmly kept in position, and the skin should be thoroughly moistened with tepid water.

Erb's standard electrode has a surface area of 10 square centimetres; the medium size 20 square centimetres; the large size 50 square centimetres (2 by 4 inches). It would be more convenient to measure the diameters in multiples of 1.25 cms.

	<i>Diameter in cms.</i>		<i>Diameter. in inches.</i>
Thus a 'small' size would be	- 1.25	-	$\frac{1}{2}$
„ 'medium' size would be	- 2.5	-	1
„ 'large' size would be	- 5.0	-	2
„ 'very large' size would be	10.0	-	4

The body is made up of such a complex, heterogeneous, and irregularly-placed series of substances that it is quite impossible for it to have a specific resistance. We are, therefore, obliged to measure its total resistance; the larger portion of this, we know, resides in the skin. This has been proved in various ways, by the insertion of needles, and by removal of the epidermis (Kohler, Gaertner, Jolly); the latter estimated the resistance of the skin as 150 times that of the intervening tissues (with electrodes of 4 square centimetres). A simpler method is to vary the sizes of the electrodes, for if the main resistance is to be found in the skin, the current-strength should vary with these—*i.e.*, the resistance should vary inversely with the size of the electrode. Broadly speaking, this is found to be the case, though there is no mathematical relation; moreover, as the resistance of the skin diminishes with the successive increases in size of the electrodes, so the resistance of the intervening

tissues becomes more and more a factor. When every precaution has been taken, the resistance may still vary very greatly in a healthy body. Suppose we take the average resistance from sternum to nape of neck to be about 2,500 ohms, it might be 5,000 or more, or 1,000 or less, without being of significance. The following are some of the resistances (measured by Kohlrausch's method, *salt* and warm water being used) observed by me in healthy young adults with electrodes of 5 centimetres in diameter.

<i>Position of electrodes.</i>	<i>R. in ohms.</i>
Hand to hand - - - -	1,375
Through one hand - - - -	900
Cheek to cheek - - - -	600
Frontal eminence to frontal eminence - -	800
Just above one ankle to just above the other -	700
Through the calf of the leg - - -	350

The resistance is increased by age (Beard and Rockwell, however, consider that young people offer greater resistance than old people; p. 175, 'Med. Electricity'), by the thickness and horny nature of the epidermis, absence of hair follicles and sweat-glands, etc. (*vide* p. 65). Old people sometimes have a very great resistance. In a patient of sixty-eight the resistance, observed with the very large (10 centimetres in diameter) electrodes, from nape of neck to abdomen was regularly from 12,000 to 15,000 ohms.

### Pathologically

the resistance may be increased or diminished. It is 'increased' in some cases of hysteria, particularly if hemianæsthesia be present. The affected side may present a resistance greater than that on the sound side by more than 1,000 ohms; it is especially marked on the head (Vigouroux). If the hemianæsthesia be transferred the increased resistance accompanies it. In long-standing cases of hemiplegia, with coldness of the extremities, the resistance may be increased. In one case Dubois found it to be seven times as great as it was on the sound side.

Dr. Stone, on the other hand, observed it in similar cases to be diminished. It is 'diminished' in Graves' disease, and in some cases of chlorosis and anæmia. The diminution in Graves' disease, first noticed by Vigouroux in 1885, has been confirmed by Charcot and subsequent writers; it may be very marked. In a case under my own care, with electrodes of  $3\frac{1}{2}$  and 5 centimetres in diameter, from just beneath the ear to the seventh cervical vertebra the resistance amounted to 400 ohms.

If the galvanic current be used a very low E. M. F. is sufficient to demonstrate the diminished resistance; thus with 3 volts one may obtain 7 or 8 milliampères.

The resistance is much diminished in fevers and dropsical conditions, also in certain metallic poisonings—copper, mercury, etc. (Dr. Stone, 'Lumleian Lectures,' 1886.) Silva and Pescarolo state that every elevation in temperature is accompanied by an increased resistance—in the continued fevers, cold and hot stages of malaria, also in diabetes, during convalescence after infectious diseases, etc. The resistance is greater in ascites before the withdrawal of the fluid than it is after.

According to the law governing the resistance of electrolytes, one would expect the body resistance to be lowered by a fever; this effect may, however, be counterbalanced by the dryness of the skin: it should at any rate be diminished in acute rheumatism. It is obvious, then, that but little can be at present learnt from the resistance of the body as a whole. It may vary so much in normal individuals, and is influenced by so many conditions, that a very large series of observations taken with minute precautions is required before conclusions can be drawn. Many, unfortunately, of the older and most painstaking observations are deprived of much of their value through the imperfect methods employed. There is only one way of obtaining fairly accurate results, and that is by the adoption of Kohlrausch's method and standard-sized electrodes, and this, as already mentioned, presents difficulties of its own.

With regard to the resistance of the individual tissues, most authors are agreed that the more vascular and watery the tissues may be, the better they conduct. Thus the blood is the best conductor, the muscles the next, then the nerves, and last of all the bones. Larrat (p. 117, 'Electrothérapie') gives the following table, taking the resistance of muscle as equivalent to one :

Muscle	-	-	-	-	-	1
Nerve	-	-	-	-	-	2'5
Cartilage	-	-	-	-	-	2'5
Bone	-	-	-	-	-	15 to 20
Skin and epidermis	-	-	-	-	-	100 to 500

The resistance of the first two is much influenced by the direction of the current ; it is much greater to a transverse than it is to a longitudinal current. (Six to one in the case of muscle, and three to one in that of the nerves. Chapman.)

Though these are interesting facts which give us an idea of the path the current will choose in traversing the body, they cannot be tested during life. Much more may be learnt by an electrical examination of the blood and of the secretions, and especially of the urine. The following is a brief account of some experiments made by me in this direction, and communicated to the Royal Society of Edinburgh on December 21, 1891.

The object of the inquiry was to ascertain the electrical resistances of various kinds of urine both in states of health and of disease. The measurements were made by means of a Wheatstone bridge with alternating currents and a telephone, according to Kohlrausch's method, and at a temperature of 65° Fahr. Fig. 100A is a view of the electrolysis tube used.

It would appear from the observations (some 500 in number) that the specific resistance of a normal urine amounts to about 45 ohms, and that it varies as a rule inversely with the specific gravity. The latter is a measure of the amount of solids in solution, and particularly of the urea. It might be supposed, then, that the resistance depends also mainly upon the amount of urea ;

this, however, is not the case. Numerous experiments were made with artificial solutions of urea, sodium chloride, phosphates, sugar in distilled water (see Table I., 1, 3, 4), and from these it is clearly apparent that the electrical

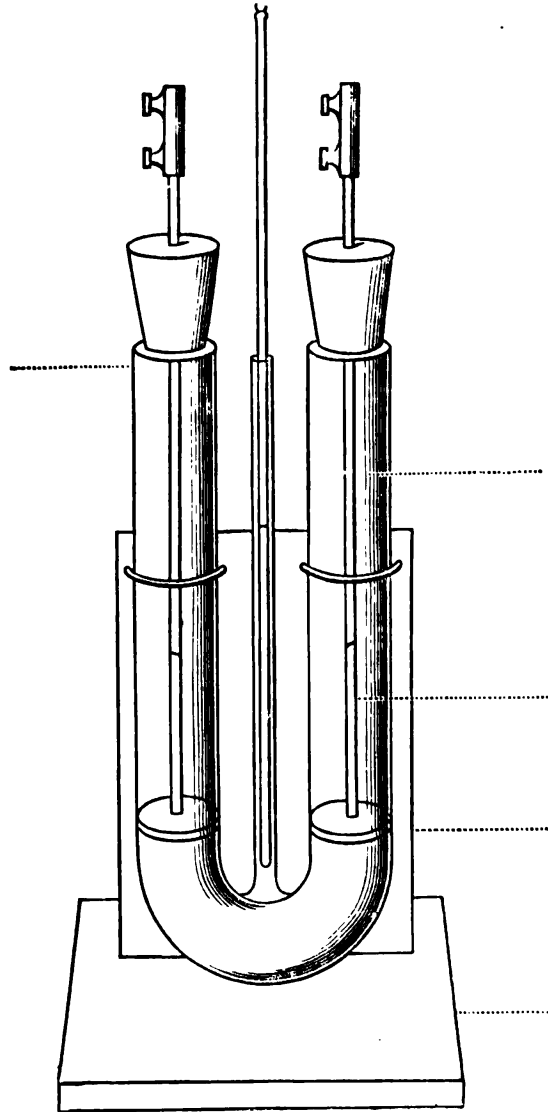

FIG. 101A.—U TUBE USED FOR MEASURING THE RESISTANCE OF LIQUIDS.

resistance depends almost wholly upon the salts, chlorides, phosphates, sulphates, etc., and that it is only when these are absent, or diminished, that the influence of the urea makes itself felt. The resistance is therefore a measure of the chemically active substances in a urine, of the salts

(p. 172), and to a very much less degree of the inert urea. This gives us a simple and rapid method of estimating the constitution of a urine as regards its salts, while the specific gravity in the absence of sugar is a guide to its urea.

In a normal urine, as already stated, these go more or less inversely together ; given the specific gravity, the resistance can be estimated ; and given the resistance, the specific gravity can be calculated.

To the rule ' that the resistance varies inversely with the specific gravity ' there are certain exceptions : these can be arranged accordingly as they occur in acute or in chronic diseases.

Excluding acute infectious diseases and local surgical affections, the two most prominent exceptions are, amongst the former, acute croupous pneumonia ; amongst the latter, diabetes mellitus.

That the urine of a case of pneumonia should offer a higher electrical resistance than would be predicated from its specific gravity is easily understood when the great diminution of the chlorides in the urine of a case of this disease is remembered ; but the increased resistance of a diabetic urine affords a question of a more interesting nature ; in this disease the specific gravity of the urine is high, and the electrical resistance offered by it is also high, and sometimes very high.

Thus the specific gravity may be considerably above 1030, and the resistance at the same time as much as 150 ohms, while the resistance of an ordinary urine of a specific gravity of 1030 would probably be below 40 ohms (see Table II.).

Upon what does this increased resistance depend—on a diminution in the salts, or on the presence of the sugar ? Almost wholly on the former ; the table (Nos. 1 and 2) of experiments with artificial solutions shows us that a 1 per cent. solution of sodium chloride has a resistance of 59.5 ohms, and that the addition of 10 per cent. of grape sugar only raises the resistance to 68 ohms. A 2 per cent. solution of sodium chloride has a resistance of 29.25 ohms ;

the addition of 20 per cent. of sugar raises it to 51 ohms, and of 30 per cent. of sugar to 63·75 ohms. With smaller percentages of sugar there may be scarcely any effect (Table I., 1, 2, 4). It cannot therefore be doubted that the sugar, probably hindering diffusion by its viscosity, does to a slight extent raise the resistance of a saline solution. (It will lower the resistance of distilled water when by itself.) But by far the greater part of the increased resistance of a diabetic urine is due to the relatively great diminution in the salts, and it is to the credit of the electrical testing that this fact is brought so prominently forward.

It will be found, further, that this resistance usually diminishes with the amount of sugar passed, and that the record of it may be utilized as a test of the patient's progress. Whenever we find a high specific gravity together with a high electrical resistance (above 80 ohms specific resistance), we may suspect the presence of sugar; the specific gravity is raised by the sugar, and the resistance is increased by the diminution of the salts (Table II.).

In acute and chronic Bright's disease the resistance is high; also usually in mitral disease and anæmia, particularly pernicious anæmia. The effect of diet has to be considered. Copious draughts of water increase the resistance, taking much salted food diminishes it, etc. The urine passed in the early morning—if a late dinner or supper is eaten—commonly has a relatively low resistance. Some of the principal tables are appended. No. 3 table demonstrates how small the effect of urea is compared with that of sodium chloride (Nos. 1 and 4).

I.—TABLE OF SOME OF THE RESISTANCES OBSERVED WITH ARTIFICIAL URINES.

I. SODIUM CHLORIDE.				<i>Specific resistance in ohms.</i>		
<i>Strength of solution.</i>			<i>Temp.</i>			
0·5 per cent.	-	-	65°	-	-	110·5
0·75 "	-	-	65°	-	-	79·9
1 "	-	-	65°	-	-	59·5
2 "	-	-	65°	-	-	29·25
						13



## 194 A MANUAL OF PRACTICAL MEDICAL ELECTRICITY

### 2. SODIUM CHLORIDE + GRAPE SUGAR.

<i>Strength of solutions.</i>			<i>Specific resistance</i>		
<i>Sodium chloride.</i>	<i>Sugar.</i>	<i>Temp.</i>	<i>in ohms.</i>		
1 per cent. -	10 per cent. -	65° -	-	68	
2 " -	20 " -	65° -	-	51	
2 " -	30 " -	65° -	-	63·75	

### 3. UREA ALONE.

<i>Strength of solution.</i>			<i>Specific resistance</i>		
<i>Temp.</i>				<i>in ohms.</i>	
65° -	-	-	-	1,785	
65° -	-	-	-	977·5	
65° -	-	-	-	569·5	
65° -	-	-	-	382·5	
65° -	-	-	-	272	
65° -	-	-	-	229·5	

### 4. UREA + SODIUM CHLORIDE + GRAPE SUGAR.\*

<i>Strength of solutions.</i>				<i>Specific resist-</i>	
<i>Urea.</i>	<i>NaCl.</i>	<i>Sugar.</i>	<i>Temp.</i>	<i>ance in ohms.</i>	
2 per cent. -	1 per cent. -	2 per cent. -	65° -	-	59·5
2 " -	1 " -	4 " -	65° -	-	59·5
2 " -	1 " -	8 " -	65° -	-	68

II.—TABLE OF OBSERVED AND OF SPECIFIC ELECTRICAL RESISTANCES IN VARIOUS URINES.

Number.	Disease.	Specific gravity.	Reaction.	Temperature.	Urea in grs. per ounce.	Albumen.	Sugar in grs. per ounce.	Observed resistance (ohms).	Specific resistance (ohms).
1	0	1026	acid	65°	11	0	0	185	31·45
2	0	1024½	"	"	11·7	0	0	185	31·45
3	0	1027	"	"	10·29	0	0	195	33·15
4	0	1027	neutral	"	12·16	0	0	215	36·55
5	0	1027	acid	"	13·1	0	0	227	38·59
6	0	1017	neutral	"	7·4	0	0	258	43·86
7	0	1012	acid	"	4·21	0	0	370	62·9
8	0	1009	"	"	5·85	0	0	435	73·9
9	0	1010	"	"	1·5	0	0	700	119
10	Exoph. goitre	1005	"	"	1·4	0	0	900	153
11	Diabet. mellitus	1034	"	"	4·68	0	25	920	156·4
12	" "	1034	"	"	6·08	0	27	820	139·4
13	" "	1034½	"	"	5·6	0	30	775	131·75
14	" "	1034	"	"	6·8	0	27	760	129·2
15	" "	1040	"	"	8·1	0	28	732	124·44
16	" "	1025	"	"	6·08	trace	14	540	91·8
17	" "	1036	"	"	13·1	0	17	320	54·4
18	Artificial diab.*	1040	"	"	10·76	0	30	220	37·4

\* Thirty grammes of grape sugar per ounce added to a normal urine.

This table in the first ten experiments exhibits the usual relation that exists between the specific gravity and the resistance, viz., their inverse variation to each other ; the others show the high resistance usually present in diabetes, and the negative effect of adding a small quantity of grape sugar to a normal urine.

By this means, then, we are enabled to make an immediate rough estimation of the constitution of a urine, and particularly of its salts, chlorides, phosphates, sulphates, etc., a result which could only otherwise be arrived at by a tedious chemical analysis. The specific gravity of a urine depends, in the absence of sugar, mainly upon the urea, the electrical resistance upon the salts. By combining these, we can at once form a fair idea of a urine's constitution, and of the kidney's efficiency.

For illustration, I append the resistances of the urine of a patient, J. B., suffering from subacute Bright's disease :

<i>Date.</i>	<i>Specific gravity.</i>	<i>Reaction.</i>	<i>Temperature.</i>	<i>Urea, grs. per ounce.</i>	<i>Albumen.</i>	<i>Observed resistance in ohms.</i>	<i>Specific resistance in ohms.</i>
Dec. 8, 1891	1011	acid	65	4	blood-albumen	675	114·75
" 11, 1891	1012	"	65	4·68	"	625	106·25
Jan. 9, 1892	1013	neut.	65	4·68	albumen	525	89·2
" 20, 1892	1011	acid	65	3·6	blood-albumen	550	93·5
" 30, 1892	1015	"	65	3·74	"	450	76·5
Feb. 11, 1892	1010	neut.	65	3·04	"	430	73·1
" 15, 1892	1014	acid	65	4	"	360	61·2
" 23, 1892	1015	"	65	4·68	"	350	59·5
" 28, 1892	1015	"	65	5·85	less blood-albumen	375	63·75
Mar. 5, 1892	1016	"	65	5·6	more blood and albumen	360	61·2
" 12, 1892	1017	"	65	4·68	blood-albumen	440	74·8
" 24, 1892	1020	"	65	9	albumen	375	63·75
May 28, 1892	1024	"	65	8·19	"	250	42·5

The patient was kept on milk diet until March 15. He has now been at work for two months, and considers himself to be quite well. It will be noticed that the resistance

fell before the specific gravity or urea had much altered ; it was, in my opinion, the most trustworthy guide.

Such illustrations could be multiplied. I will add one other, which is interesting from the circumstances under which the improvement occurred. A patient (under Dr. Affleck's care in the Edinburgh Royal Infirmary), apparently suffering from pernicious anæmia, and growing worse, had 5 ounces of blood transfused on February 16. After this he steadily improved, and is now quite restored to health. The resistances, taken a month before, just before, just after, and some time after transfusion, are very instructive :

<i>Date.</i>	<i>Specific gravity.</i>	<i>Reaction.</i>	<i>Temperature.</i>	<i>Urea.</i>	<i>Albumen.</i>	<i>Observed resistance in ohms.</i>	<i>Specific resistance in ohms.</i>
Jan. 16 - - - -	1017	acid	65	9.36	0	400	68
Feb. 11 - - - -	1015	„	65	6.31	0	460	78.2
Feb. 16 (before transfusion)	1014	„	65	7.72	0	680	115.6
Feb. 16 (after transfusion)-	1014	„	65	6.55	blood	680	115.6
Feb. 17 - - - -	1012	„	65	6.08	0	675	114.75
Mar. 1 - - - -	1020	„	65	7.02	0	300	51
Mar. 12 - - - -	1019	„	65	7.	0	260	44.2

It is quite obvious that, in this case, the resistance best reflected the patient's condition, steadily increasing as he grew worse, and diminishing as he grew better. The urine to be examined should be fresh, and should be a specimen taken from the whole amount passed in the twenty-four hours. The resistance diminishes as the urine is kept from fermentation changes.

The specific resistance of ascitic and pleuritic fluids (not purulent) is somewhat greater than that of the urine, amounting to about 76 ohms.

It is no easy task to measure the electrical resistance of the blood. The principal difficulty depends upon the fact that only very small quantities of blood can generally

be obtained at a time. During the last seven years many attempts have been made by me to obtain trustworthy and consistent results; various methods and forms of apparatus have been employed and subsequently rejected. The best results were obtained by placing 5 cubic millimetres of freshly-drawn blood between two cup-shaped electrodes 3 millimetres in diameter, coated with spongy platinum, and fixed at 0.75 millimetre apart.

The average resistance of normal blood at 60° F. measured by Kohlrausch's method in this apparatus is 550 ohms, the specific resistance is 93.5 ohms. A striking change may be observed in pernicious anæmia, the resistance in this disease being sometimes diminished to about one half (300 ohms) that of normal blood. The deduction is that the blood in pernicious anæmia contains an abnormal amount of salts, due to the destructive metabolism going on. We have seen that the resistance of the urine in this disease is greatly increased (about 600 ohms). Hence we have the striking fact that, while the urine contains too few salts, the blood contains an abnormal amount. The kidneys, then, must obviously be in fault. In a patient, aged fifty-one, suffering from pernicious anæmia, under the care of Dr. A. James, in the Edinburgh Royal Infirmary, the blood resistance, measured on February 25, 1902, amounted to 300 instead of to the normal 550 ohms. The resistance of the urine, measured at the same time, amounted to 500 ohms instead of to the normal 260 ohms. The blood corpuscles numbered 900,000. The blood resistance in diabetes mellitus is high, like that of the urine. A number of experiments were made by me to ascertain the time occupied by ingested sodium chloride to reach the blood. The blood resistance in five cases was measured before taking 30 grains of the salt and at five-minute intervals afterwards. The average time taken for the first lowering of the resistance of the blood was 15.4 minutes, and the maximum effect was produced in 21.4 minutes. The specific resistance of cerebro-spinal fluid is 29 ohms (Eulenberg).

The latter, then, would appear to be the best conductor in the body, the urine next, then the blood and muscles, etc. The specific resistance of cow's milk is about 170 ohms. A salt solution of 0.6 per cent. strength (about the strength of the salt content of the blood) has a specific resistance of about 85 ohms.

Dr. Gibson has shown that the resistance of milk diminishes as the milk sours, owing to the conversion of the sugar into lactic acid.

The following table gives the specific resistances of some of the tissues :

<i>Tissue.</i>				<i>Specific resistance in ohms.</i>
Cerebro-spinal fluid	-	-	-	29
Urine	-	-	-	45
Blood	-	-	-	93.5
Muscle, longitudinally	-	-	-	200*
„ transversely	-	-	-	1,300*
Nerve, longitudinally	-	-	-	1,200*
„ transversely	-	-	-	3,200*

It is advisable before proceeding to test the reactions of the nerves and muscles to measure the resistances of the parts to be examined on both the healthy and diseased sides. It will help to eliminate error in the faradic reactions. Thus, in my own case, the resistance from the lower part of the sternum (electrode 5 centimetres in diameter) to the ulnar nerve at the elbow (electrode 1.25 centimetres in diameter) is about 1,500 ohms on both sides of the body.

### The Capacity of the Body.

The electrostatic capacity of the human body has been measured by various observers (Bordier, Salomonson, Metz, etc.), with results that are not in close agreement. By the term capacity (p. 10) is meant the amount of electricity the body will hold at unit potential. The capacity of an isolated and insulated sphere is proportional to its radius. De Metz, using the ballistic method

\* Chapman and Brubacker.

of measurement, found that the capacity of the human body (Castex, 'Précis d'Électricité Médicale,' p. 255) was exactly equal to the capacity of a metallic conductor of the same form and dimensions ; it varies, therefore, with the dimensions of the individual and also with his posture, and is, of course, augmented if he be approached by another conductor connected to earth (principle of Leyden jar) ; in round numbers, he comes to the conclusion that an erect man's capacity is equal to 0'00011 microfarads. (The microfarad is the practical unit of capacity ; the capacity of the earth is about 700 microfarads.) This figure does not agree with, but is higher than, the calculated capacity of a metallic conductor presenting the same surface area as a man, and it is therefore probable that the closely-packed and overlying human tissues play to some extent the rôle of a condenser. The capacity of the body has to be taken into account in the adjustment of the resonator in high-frequency treatment.

## CHAPTER II

### EXAMINATION OF THE REACTIONS OF THE NERVES AND MUSCLES

A SWITCH-BOARD or a good battery with a collector which throws in individual cells, a current reverser, standard electrodes with a make and break arrangement in the handle, a dead-beat milliampère meter, and an induction coil with a separable secondary, moving along a scale divided into millimetres, and an arrangement for varying the rate of the interruptions, are all of essential importance. To prevent mistakes as to the poles, it is well to have the rheophores of different colours. The attempted investigation of difficult and obscure pathological cases with imperfect electrical apparatus is a source of great trouble and annoyance.

#### Motor Points.

Connect the rheophores to the secondary coil of the faradic apparatus, place the large electrode (anode) on the sternum, and move the small one (kathode) about over the muscles of the forearm. It will be found that muscular contractions are more easily produced in some places than in others. These are termed the motor 'points' (points at which the muscles are most readily stimulated), and they indicate the positions at which the motor nerves enter the muscles; a muscle may have more than one. The most important of them should be carefully studied. Von Ziemssen's plates sufficiently indicate their positions, as well as those that are most favourable for exciting a

whole nerve-trunk and group of muscles. Of the latter we may briefly mention :

‘ The facial nerve,’ just in front of, and a little below, the external auditory meatus, or just within the meatus.

‘ The phrenic ’ outer border of lower part of the sternomastoid (important for artificial respiration).

‘ The median,’ about the middle of the bend of the elbow.

‘ The ulnar,’ in the hollow between the olecranon and internal condyle, or a little above it.

‘ The musculo-spiral,’ on the outer side of the upper arm, midway between the insertions of the deltoid and the external condyle.

‘ The anterior crural,’ a little external to the femoral vessels.

‘ The great sciatic,’ in the middle line just below the gluteal fold ; a strong current and deep pressure are required.

‘ The peroneal,’ in the popliteal space at the level of the head of the fibula beside the biceps tendon.

‘ The tibial,’ in the middle line of the popliteal space.

A fixed method of procedure is of service in electro-diagnosis. The patient should be seated and a vessel of tepid water, into which the electrodes should be constantly dipped, with a sponge for moistening the places of application, should be at hand.

Begin with the faradic current, and compare the reactions of the healthy with those of the diseased side. Secure the large electrode (anode) to the sternum by a tape passing round the body (or the adhesive electrode may be used), and holding the small electrode, fitted with a make and break key, in the right hand, move it about over the various motor points of the healthy side ; this leaves the left hand free to carry out the electrical manipulations. Separate the coils to their greatest distance, arrange the hammer for slow interruptions, and turn on the current ; gradually bring the coils together, and make a note of the point in millimetres distance at which the muscles first contract ; then let the hammer vibrate rapidly, and



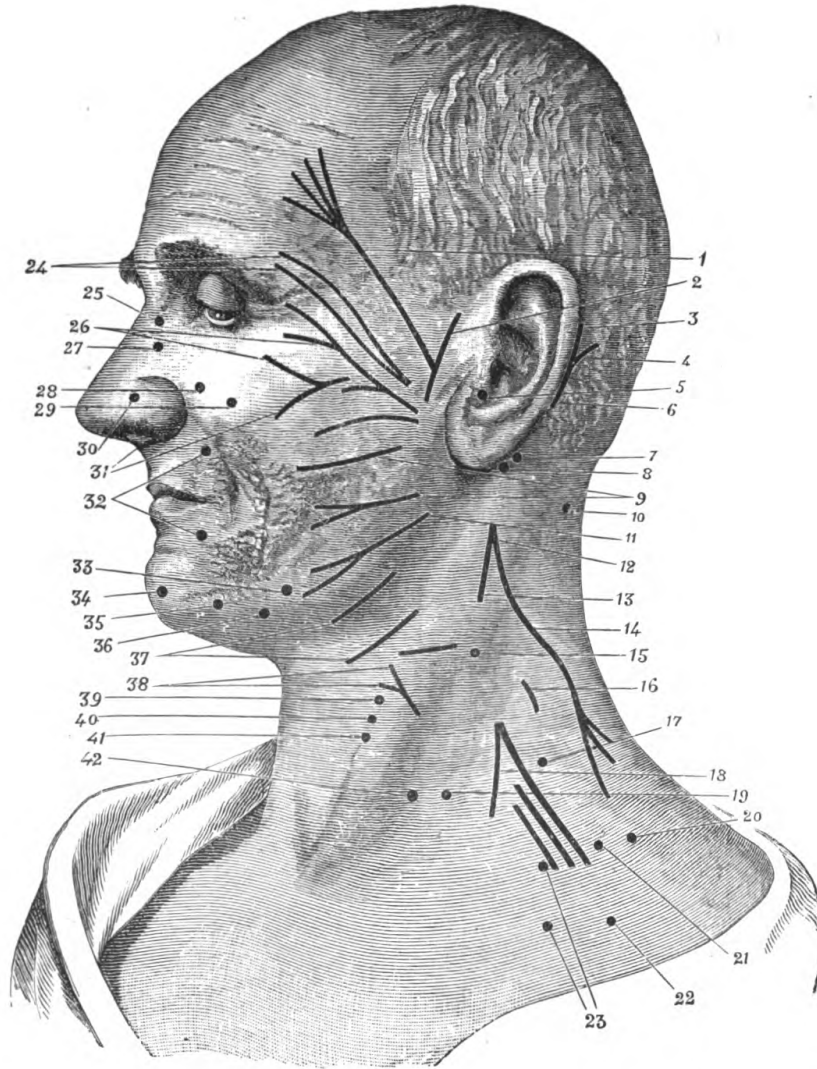

FIG. 101.—MOTOR POINTS OF HEAD AND NECK (Ziemssen).

## EXPLANATION OF FIG. 101.

1. Frontalis muscles.
2. Attrahens and attollens auriculam muscles.
3. Retrahens and attollens auriculam muscles.
4. Occipitalis muscle.
5. Facial nerve.
6. Posterior auricular branch of facial nerve.
7. Stylohyoid muscle.
8. Digastric muscle.
9. Buccal branch of facial nerve.
10. Splenius capitis muscle.
11. Subcutaneous branches of inferior maxillary nerve.
12. External branch of spinal accessory nerve.
13. Sterno-mastoid muscle.
14. Cucullaris muscle.
15. Sterno-mastoid muscle.
16. Levator angulæ scapulæ muscle.
17. Posterior thoracic nerve.
18. Phrenic nerve.
19. Omohyoid muscle.
20. Nerve to serratus magnus muscle.
21. Axillary nerve.
22. Branch of brachial plexus (musculo-cutaneous and part of median).
23. Anterior thoracic nerve (pectoral muscles).
24. Corrugator supercilii muscles.
25. Compressor nasi and pyramidalis nasi muscles.
26. Orbicularis palpebrarum muscle.
27. Levator labii superioris alæque nasi muscle.
28. Levator labii superioris muscle.
29. Zygomaticus minor muscle.
30. Dilatator naris.
- 31.\* Zygomaticus major.
32. Orbicularis oris.
33. Branch to triangularis and levator menti muscles.
34. Levator menti muscle.
35. Quadratus menti muscle.
36. Triangularis menti muscles.
37. Cervical branch of facial nerve.
38. Branch to platysma muscle.
39. Sternohyoid muscle.
40. Omohyoid muscle.
41. Sternothyroid muscle.
42. Sternohyoid muscle.

\* The upper of the two lines that converge on 31 should have been directed to 30, as it applies to the dilatator naris posterior muscle.

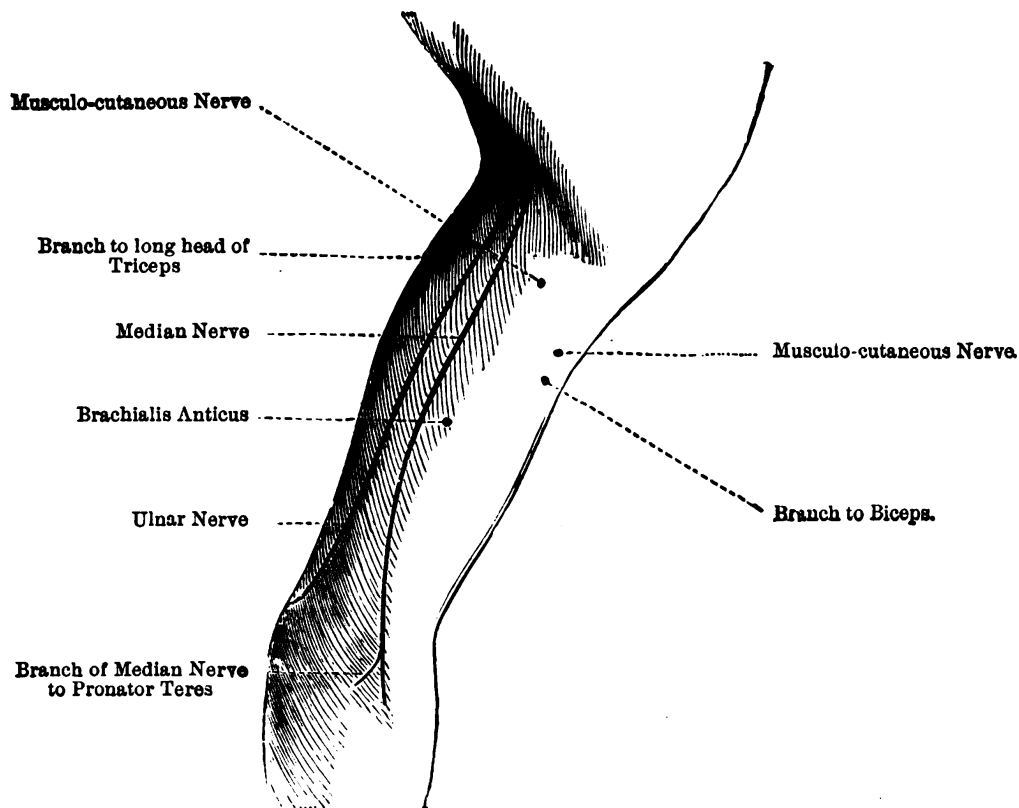

FIG. 102.—MOTOR POINTS OF ANTERIOR SURFACE OF LEFT ARM (Ziemssen).

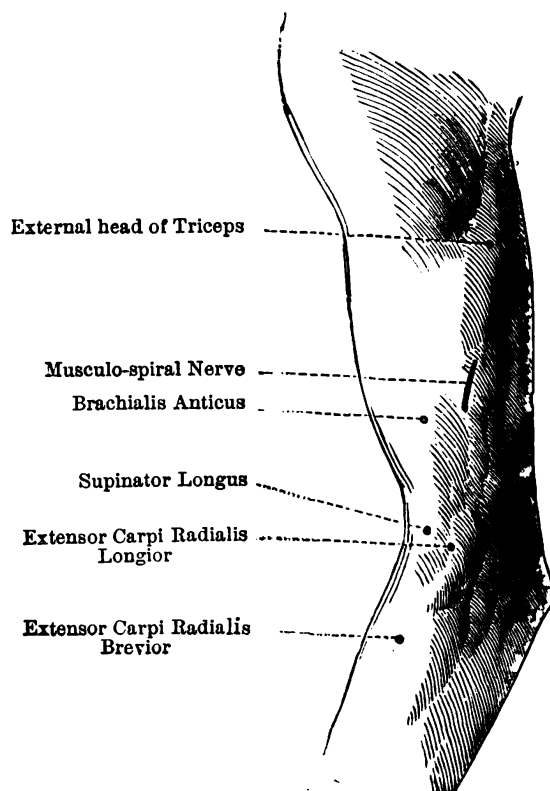

FIG. 103.—MOTOR POINTS OF POSTERIOR SURFACE OF LEFT ARM (Ziemssen).

repeat ; contractions will be obtained with the coils at a slightly greater distance. Perform the same series of operations on the diseased side, and compare the results.

Then take the galvanic current, and note down syste-

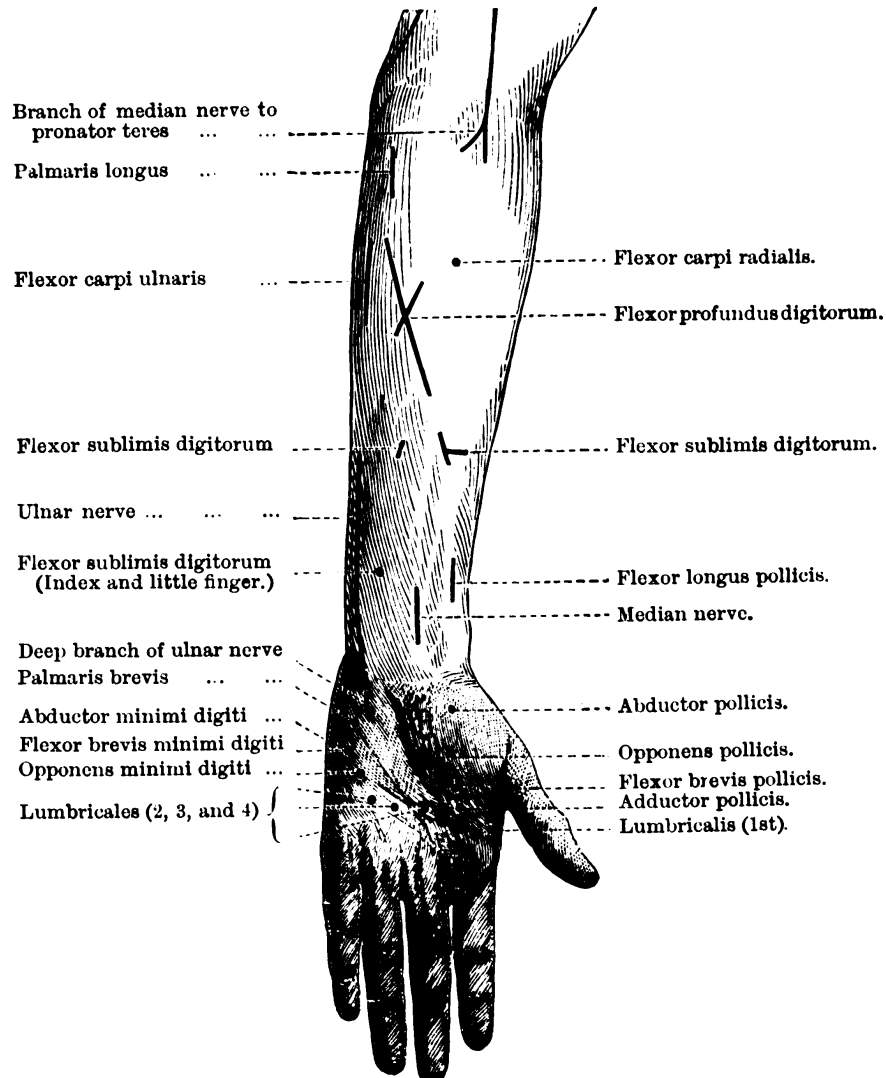

FIG. 104.—MOTOR POINTS OF THE FOREARM (Ziemssen).

matically the strength of current necessary to obtain the respective polar reactions on both sides. K.C.C. 'A.C.C. A.O.C. K.O.C. Observe particularly also the character of the contractions—whether they are short, sharp and sudden, or slow in appearing, and prolonged.

In various diseased conditions, the normal reactions of the muscles and nerves to electrical stimulation are altered. The changes may be either *quantitative* or *qualitative*.

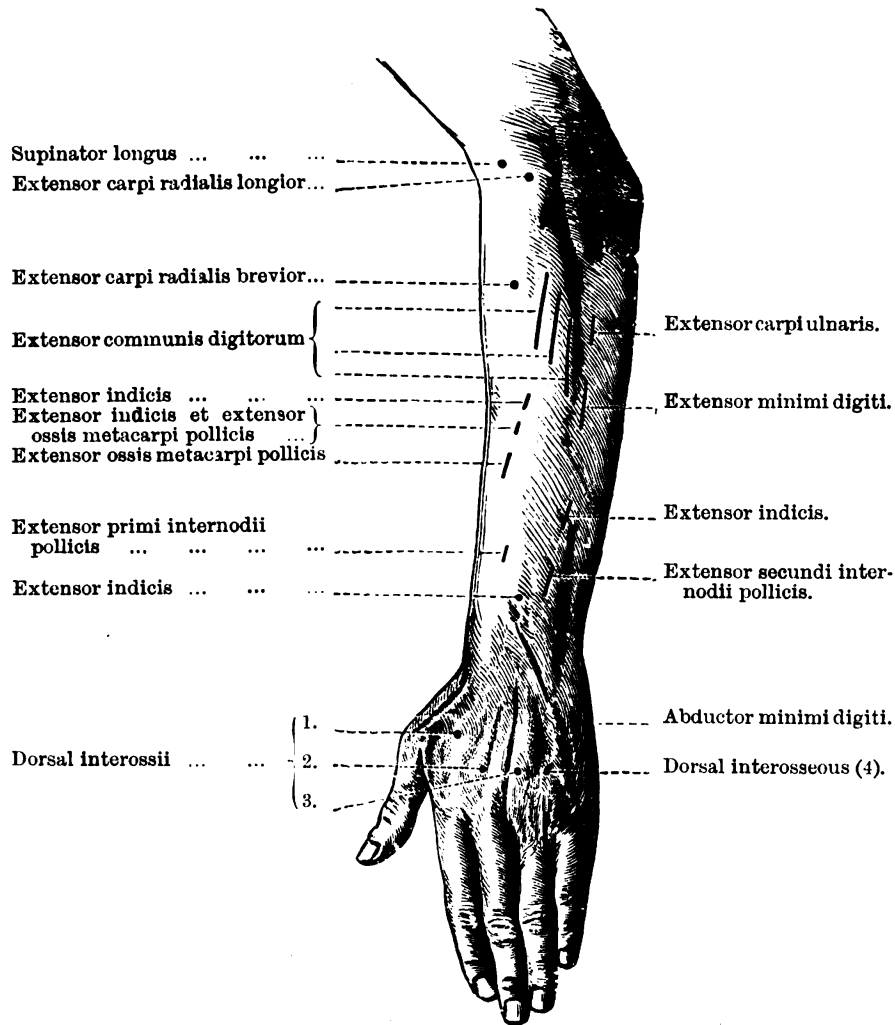

FIG. 105.—MOTOR POINTS OF THE FOREARM (Ziemssen).

### Quantitative Changes.

These may be divided into three classes :

- (a) The nerves or muscles may be superexcitable.
- (b) The nerves or muscles may be subexcitable.
- (c) The nerves or muscles may not react at all.

Combinations of these conditions are also possible, *e.g.*,

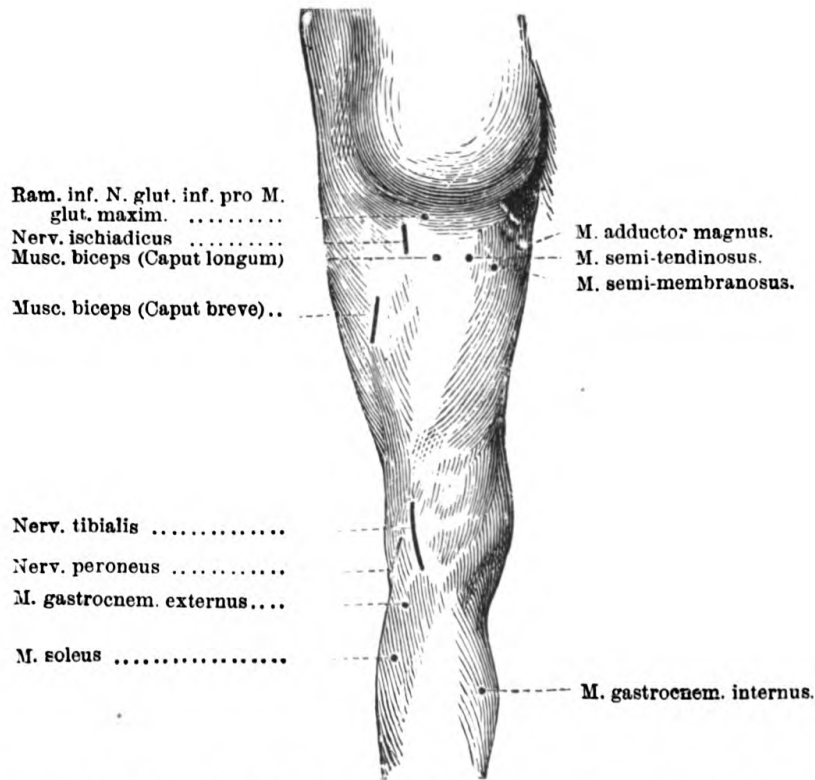

FIG. 106.—MOTOR POINTS OF POSTERIOR SURFACE OF THIGH (Ziemssen).

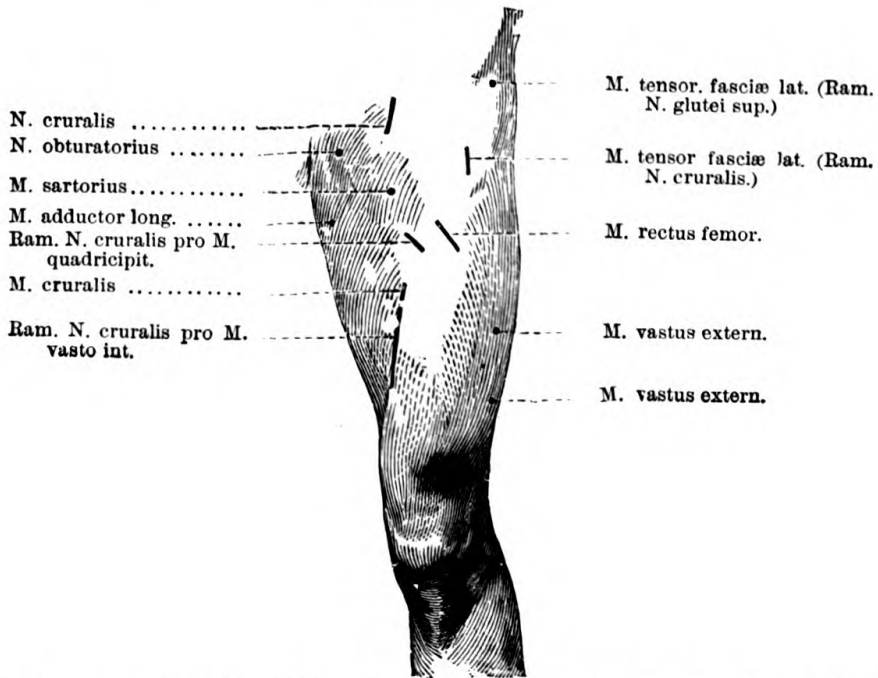

FIG. 107.—MOTOR POINTS OF ANTERIOR SURFACE OF THIGH (Ziemssen).

the muscles may be superexcitable, and the nerves subexcitable, etc.

(a) Faradic Superexcitability.

The faradic quantitative changes are slightly more difficult to gauge than are the galvanic, because there exists at

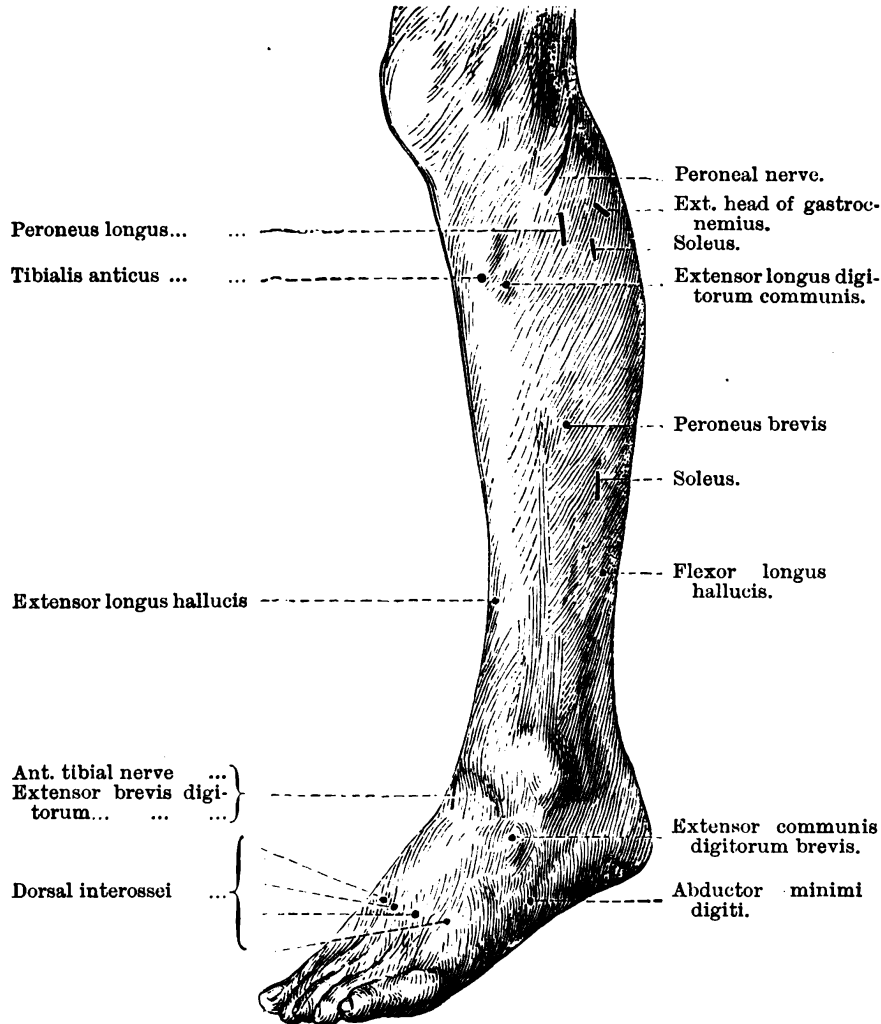

FIG. 108.—MOTOR POINTS OF OUTER SURFACE OF LEG (Ziemssen).

present only the hot-wire milliampère meter wherewith to measure the current-strength of induced alternating currents. A comparison of the reactions of the two sides will be of most value, particularly if the galvanometer, used

subsequently with the constant current, shows that there is no great difference in the relative body resistances. Greater accuracy will be obtained if the chief resistances of the body have been previously measured by Kohlrausch's method.

By the term 'superexcitability,' we mean that the

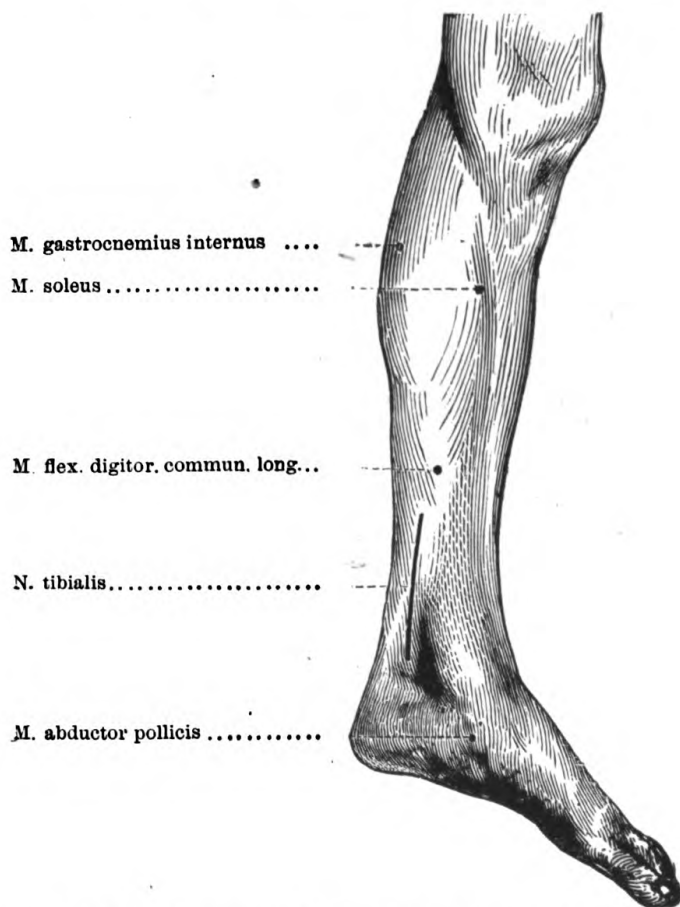

FIG. 109.—MOTOR POINTS OF INNER SURFACE OF LEG (Ziemssen).

nerves and muscles are stimulated by currents of a strength insufficient (with the coils too far apart) to stimulate normal tissues, or that the muscles react more actively and energetically to currents of the same strength; this condition usually also implies rapid exhaustion. It is met with chiefly in conditions of irritation, where the reflex excitability is also heightened, as in chorea, tetany,



spastic paralysis, early stage of locomotor ataxy, and hysterical paralysis.

### Galvanic Superexcitability.

If a muscle reacted to an interruption when the current-strength was 1 m.a. or less, and particularly if this contraction were prolonged, and showed a tendency to be

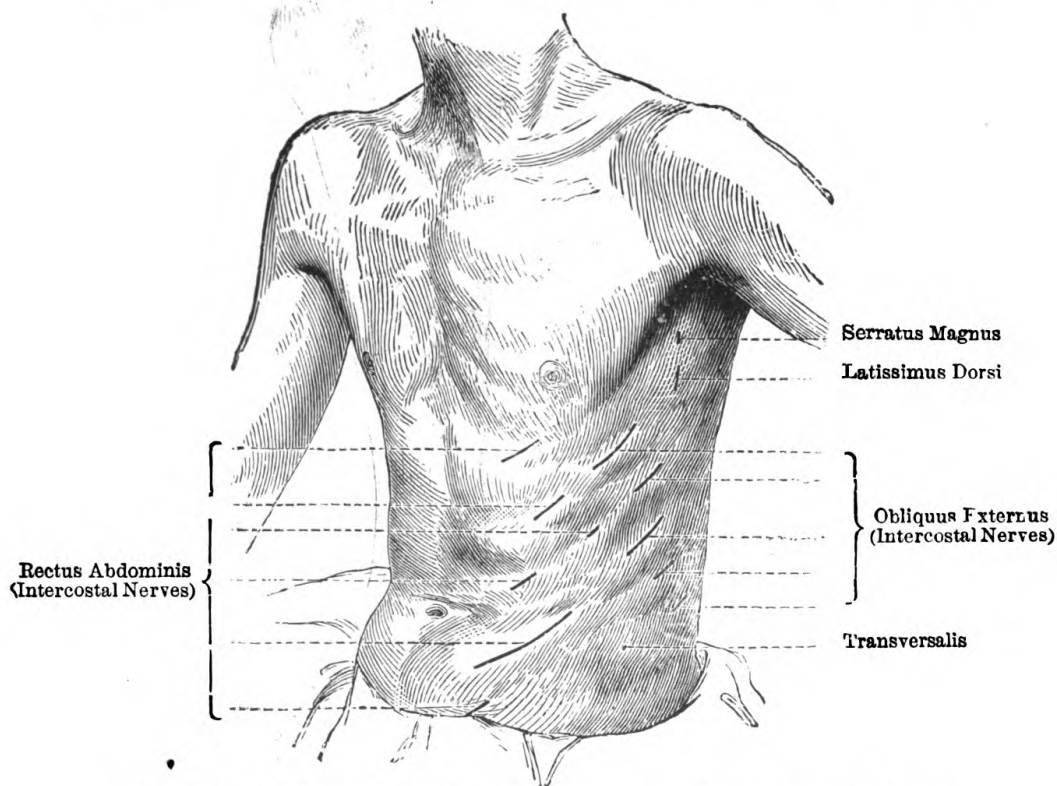

FIG. 110.—MOTOR POINTS OF ANTERIOR SURFACE OF TRUNK (Ziemssen).

tetanic, it might *cæteris paribus* be considered to be superexcitable. The condition is found in the same class of cases as the above, but with some important additions as regards the muscles, viz., in the early stages of peripheral neurites of all kinds, rheumatic (facial), traumatic, alcoholic, etc., also of infantile paralysis—in fact, it may be found in the early stages of all conditions involving a lesion of the second trophic realm (*vide* reaction of degeneration).

**(b) Faradic Subexcitability.**

The muscles and nerves do not react to currents which would be of sufficient strength to stimulate normal tissues.

This condition is met with in the peripheral neurites, and other cases above mentioned ; also in pseudo-hypertrophic paralysis, myopathic muscular atrophies, long-standing cases of locomotor ataxy, and whenever the reaction of degeneration is complete.

**Galvanic Subexcitability.**

(*E.g.*, if K.C.C. or A.C.C. could not be obtained with a current-strength of 10-15 m.a.)

This condition is present in pseudo-hypertrophic paralysis, myopathic muscular atrophies, and cases of protracted reaction of degeneration, etc.

(*c*) If the last-mentioned conditions are of long standing there may be a total loss of reaction to all varieties of electrical stimulation.

It is of importance to distinguish the faradic and galvanic quantitative reactions, for it will have been observed that they are in certain cases in absolute contradiction.

## CHAPTER III

### QUALITATIVE CHANGES

OF these there are two divisions : (a) 'serial,' (b) 'modal.'

(a) 'Serial.' Occurrence of contraction in a different order to the normal.

(b) 'Modal.' Alterations in the manner and nature of the contractions.

These changes are met with in the condition termed 'reaction of degeneration,' often expressed by 'R.D.' Erb was the first to introduce the term, under which he includes the regular series of quantitative and qualitative modifications of electrical excitability characteristic of certain morbid conditions of nerve and muscle, and intimately related to a process of degenerative atrophy occurring in the nerves and muscles together. He defines it as characterized essentially by 'the diminution and loss of faradic excitability in both nerves and muscles, whilst the galvanic excitability of the latter remains unimpaired, is sometimes notably increased, and always undergoes definite qualitative modifications.' The reaction of degeneration, being pathognomonic of certain diseases, is of the utmost importance in diagnosis.

#### Ætiology of R.D.

This condition may be met with whenever there is a lesion of the second trophic realm, or lower segment (that part of the motor path which, commencing at and including the multipolar ganglion cell in the anterior cornu of the spinal cord, is continued down to terminate in the motor end plate of a muscle).

It may be found, then, in certain spinal affections and peripheral nerve affections.

The chief spinal affections in which R.D. occurs are :

- Poliomyelitis anterior (acute, chronic).
- A myelitis involving the ant. horn.
- Progressive muscular atrophy of spinal origin.
- Amyotrophic lateral sclerosis.
- Lead paralysis.
- Labio-glosso-pharyngeal paralysis.

The chief peripheral nerve affections are :

All forms of injury or disease involving the peripheral motor nerves, *e.g.* :

- Division or bruising of the nerves.
- Crutch and pressure paralyses.
- Peripheral neurites of all kinds (alcoholic, rheumatic, diphtheritic, etc.).

It is not found in pure cerebral paralysis, nor in diseases affecting the white matter only of the spinal cord, nor in primary muscular affections, nor in the atrophies of muscles consecutive to joint affections, nor in hysterical paralysis.

### Phenomena which Characterize R.D.

These are both quantitative and qualitative.

#### 1. Quantitative.

(a) The nerve can no longer be stimulated by either galvanism or faradism.

(b) The muscles can no longer be stimulated by faradism, but are at first superexcitable to galvanism.

#### 2. Qualitative.

(a) *Serial.*—The normal order of polar contraction becomes modified, the anode taking the place of the kathode.

	<i>R.D.</i>	<i>Normal.</i>
Thus we obtain in order	(1) A.C.C. instead of	K.C.C.
„ „	(2) K.C.C.	„ A.C.C.
„ „	(3) K.O.C.	„ A.O.C.
„ „	(4) A.O.C.	„ K.O.C.

(b) *Modal*.—In place of the normal, sharp, lightning-like contraction, we observe a contraction that is tardy in appearing, prolonged in duration, and apt to become tetanic.

The curves (Figs. 111-113) taken from Erb exhibit these changes.

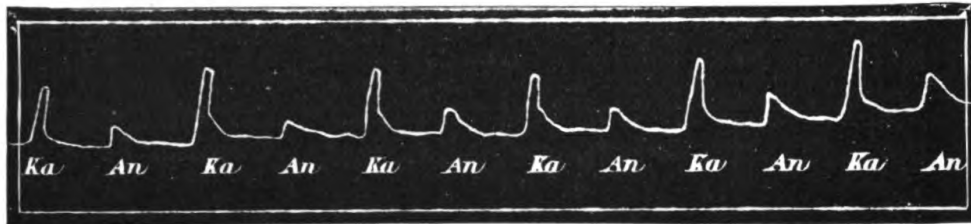

FIG. 111.—CURVE OF MUSCULAR CLOSING CONTRACTION WHEN A HEALTHY NERVE IS STIMULATED (Erb).

Ka (kathode) is a stronger stimulus than An (the anode).

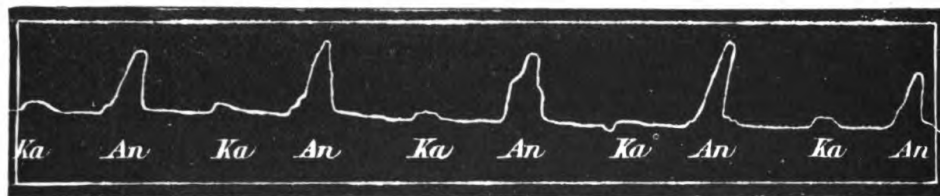

FIG. 112.—REACTION OF DEGENERATION (Erb).

The anodal closing contraction is a much stronger one than the kathodal.

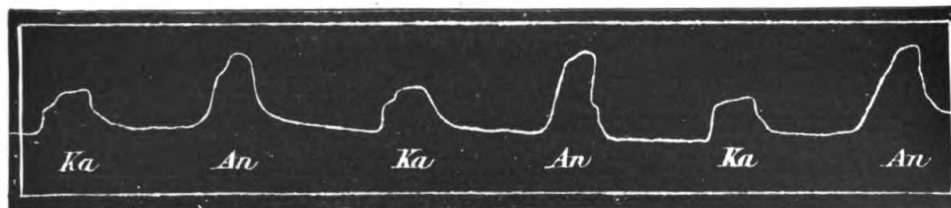

FIG. 113.—THE EFFECT OF A STRONGER CURRENT IN THE SAME CASE (Erb).

The contractions tend to become prolonged.

### Progress of a Case of R.D.

Suppose a marked case of Bell's paralysis :

1. For the first forty-eight hours after the commencement of the paralysis, all would remain apparently normal to electrical stimulation. Then would follow :

2. Gradual loss of the nerve irritability to both faradic and galvanic stimulation, so that after about ten days the muscles cannot be stimulated through the nerve.

3. At the same time the muscles gradually lose their faradic irritability, but become superexcitable to galvanism, and exhibit the 'serial' and 'modal' changes already mentioned, viz., the anode takes the place of the kathode, and the contractions become sluggish and prolonged.

4. After about six weeks the galvanic superexcitability gradually diminishes, until eventually little or no contraction can be obtained with the strongest currents. The A.C.C. remains the longest.

If the case, however, recovers, voluntary motion usually returns first, closely followed by the electrical irritability; the kathode resumes its proper position, and the modal changes disappear.

### Pathologically.

I. The effect of the lesion is to cause progressive degeneration of the nerve structure; this interferes with the

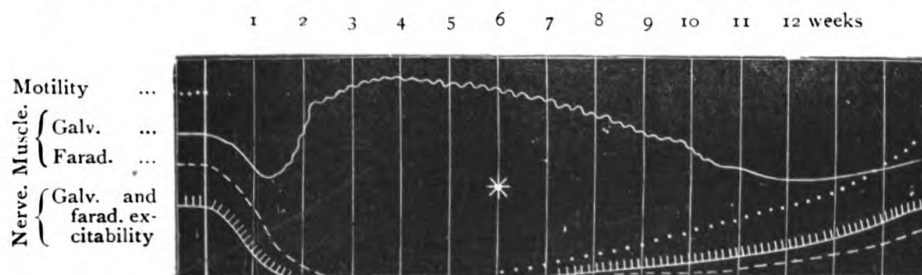

FIG. 114.—SCHEME OF THE REACTION OF DEGENERATION.

Slight form with recovery of motor power at the sixth week. The dotted line represents the voluntary motility; the star indicates the return of motor power (after Erb).

conduction of electrical stimuli, and eventually leads to complete loss of the nerve irritability.

2. The disappearance of the muscular irritability to faradism corresponds to degeneration of the intramuscular nerve fibrils and motor end plate (*vide* p. 183). (Liebig and Rohé do not accept this view.)

3. The serial and modal changes are due to degeneration of the muscular substance itself. (Loss of striation, proliferation of nuclei, etc.)

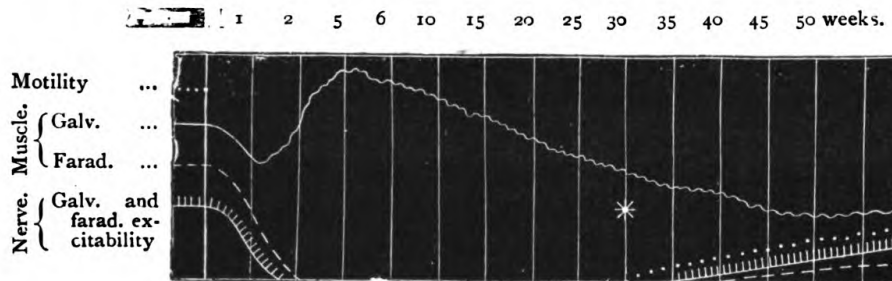

FIG. 115.—SCHEME OF THE REACTION OF DEGENERATION.

A severe form in which motor power was not recovered for thirty weeks (after Erb).

4. The gradual diminution and loss of the muscular irritability to galvanism are due to progressive cirrhosis of the muscle.

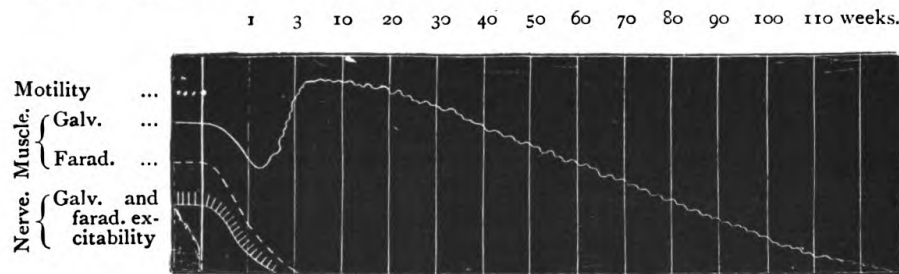

FIG. 116.—SCHEME OF THE REACTION OF DEGENERATION.

Incurable paralysis (after Erb).

The accompanying charts of Professor Erb will serve to demonstrate the phenomena.

### Varieties of R.D.

A case of complete and typical R.D. has been described, but such a case is not always met with; there are many degrees of the condition classed under the general term, 'Partial R.D.,' or 'Atypical R.D.'

In the most important variety the nerve may be quite unable to conduct voluntary impulses, though it retains the power of conducting, often somewhat less efficiently,

faradic and galvanic stimuli: The muscles respond to faradism, but in a diminished degree, while the response to galvanism is characterized by the serial and pathognomonic modal changes of complete R.D. (Fig. 117).

In another variety, occurring sometimes in lead paralysis, a complete and partial R.D. may be seen in muscles which show no signs of paralysis.

It is important to remember that the most essential

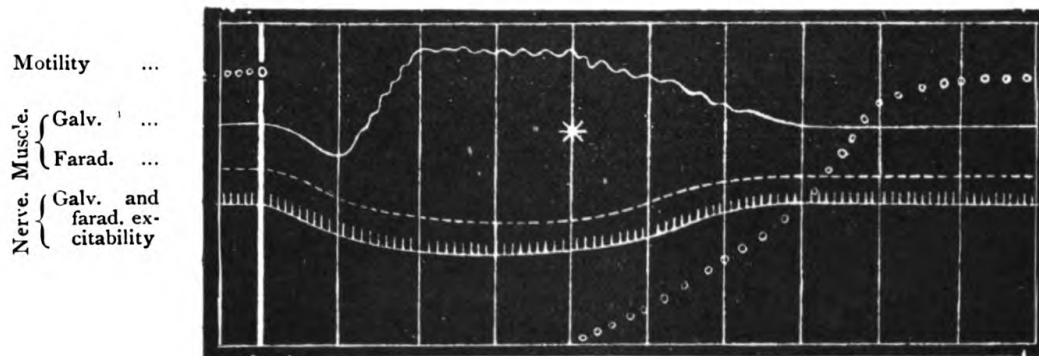

FIG. 117.—SCHEME OF THE PARTIAL FORM OF R.D.

The faradic and galvanic excitability of the nerve and the faradic excitability of the muscle are but slightly lowered. Voluntary power soon restored (after Erb).

and characteristic features of R.D. are the modal changes; without them the condition should not be diagnosed.

### Value of R.D. in Localization and Prognosis.

(a) **Localization.**—The presence of R.D. permits us to form the following conclusions:

1. The neuro-muscular area exhibiting the phenomena of R.D. is undergoing degenerative changes.

2. If only one muscle be affected, the degenerative process is confined to it and to its nerve fibril, intramuscular nerve terminations, and motor end plates.

3. If a group of muscles supplied by one nerve-trunk be affected, then the process is confined to these muscles and to the nerve-trunk supplying them, and the lesion is probably situated in the latter.



4. If groups of muscles having a physiological as well as an anatomical relation are affected, then the process includes also the anterior cornua of the spinal segments supplying these muscles, and probably also originated there.

5. If R.D. should occur in the course of any cerebral or spinal disease (hemiplegia, locomotor ataxy, lateral sclerosis, etc.), it indicates that the morbid process has extended to the anterior cornua (descending degeneration, amyotrophic lateral sclerosis, etc.).

(b) **Prognosis.**—The more marked and complete the reaction of degeneration is, the more serious is the prognosis. ‘Other things—that is, the cause and nature of the disease—being the same, the lesion is serious, the probable duration of the disease longer, the definite prospect of a cure more remote, in proportion as R.D. is developed and complete, and in proportion to the stage which it has reached. The partial is therefore a more favourable condition than the complete reaction, and its later less so than its earlier stages. It is possible, therefore, in the different forms of disease to arrive at a prognosis, which, of course, should be supported by independent considerations. In this respect the most instructive illustration may be drawn from rheumatic facial paralysis : of this three forms are distinguished according to the duration and severity of the disease, and each may be recognised by means of electrical exploration. If the electrical excitability is found to be altogether normal (mild form), the prognosis is very favourable ; the disease will last two or three weeks. If there is a partial R.D. (intermediate form) it will last one or two months ; but if the reaction of degeneration is complete (serious form) the prognosis is proportionately bad, and the paralysis will last three, six, or nine months, and even longer ’ (*Erb*).

### Sensory Nerves.

The two chief alterations with which we are electrodiagnostically concerned are ‘hyperæsthesia’ and ‘anæsthesia.’ Perhaps the simplest and most rapid method of

roughly investigating the electro-cutaneous sensibility is to make use of static electricity. Thus with the patient seated on the insulated chair, and connected with the machine, a rounded wooden or metal electrode connected to earth can be passed rapidly over the parts to be examined. This will give rise to pricking sensations or slight sparks, and lead to the rapid localization of any patches of altered sensibility.

To make a more exact diagnosis, the faradic coil and a wire-brush electrode, or Erb's special electrode made of a cable of insulated wires cut at right angles to its axis, can be made use of. The skin should be carefully dried. With the coils separated as in the investigation of the motor reactions, a systematic examination of corresponding areas on the two sides of the body should be made, and the distance in millimetres of the two coils noted, both when the first sensation of the current is felt and when pain is first felt. (The resistance of the skin must also be taken into account.)

The electro-cutaneous sensibility is a function *sui generis*; it does not run quite parallel with any other form of sensibility. It appears (especially in locomotor ataxy) to correspond rather with the sensation of pain produced by pinching.

## THE NERVES OF SPECIAL SENSE.

### The Optic Nerve.

But little is known of any qualitative changes the optic nerve may offer when diseased. There is subexcitability and gradual loss of galvanic reaction in optic atrophy:

### The Auditory Nerve.

There may be 'quantitative' and 'qualitative' changes.

I. **Quantitative**.—(a) Hyperæsthesia. (b) Torpor.

(a) *Galvanic Hyperæsthesia*.—The auditory nerve reacts by giving rise to its specific sensation at the interruptions of a current insufficient in strength (2-10 m.a.) to stimulate a normal ear.

**Conditions of Occurrence.** — Indrawn membrane ; chronic otitis media ; perforation of the tympanum ; locomotor ataxy ; and many cases of tinnitus.

(*b*) *Galvanic Torpor.*—The nerve does not respond to currents of a strength sufficient (10-20 m.a.) to stimulate a normal ear.

This condition is difficult of establishment because it is often impossible, owing to giddiness, etc., to bring out the reaction in perfectly healthy ears.

The conditions of its occurrence are consequently not yet well ascertained.

2. **Qualitative Changes.**—Alterations of the polar reactions. The formula may be the converse of the normal (*vide* p. 165), or any intermediate variations may be present. These changes may or may not be accompanied by hyperæsthesia.

**Conditions of Occurrence.**—Long-standing and aggravated disease of the middle and internal ears.

### The Gustatory Nerve.

All that has been at present established with regard to the galvanic reaction of this nerve in morbid conditions is that there may be a diminution and loss of the galvanic taste.

### Feigned Diseases.

Electro-diagnosis may be of much value here. R.D. cannot be simulated, and the unexpected application of a strong faradic current may resolve many cases of pretended paralysis. On the other hand, care should be taken, particularly in cases of railroad spine with indefinite symptoms, not to come too suddenly to a conclusion. Grave cerebral and spinal diseases may be present without any obvious alteration in the electrical reactions.

# PART IV

## ELECTRO-SURGERY

### CHAPTER I

#### SURGICAL USES OF ELECTRICITY

THE surgical uses of electricity, apart from its convenience for heating a cautery or lighting a lamp, depend upon its electrolytic and destructive power (*vide* p. 178). A continuous current is therefore a *sine quâ non*. It enables us to effect a local decomposition of the tissues exactly to the extent and within the limits desired ; it introduces no poisonous caustic, it causes scarcely any after-pain, and the absorption of its products need not be feared. It is essentially docile and manageable.

There are three chief methods of making use of it for these purposes :

1. Both poles are introduced into the tumour by means of needles ; this may be termed the bipolar method ; it is speediest, but is more apt to leave scars. The resistance of the skin is entirely eliminated. This method is used in the electrolysis of nævi, goitres, aneurisms, etc.

2. One pole only is introduced, and the other one is attached to a large external electrode ('unipolar' method). Progress is slower here, but if the negative pole be the external one, the risk of sloughing is reduced to a minimum. The resistance of the skin is partly eliminated. This method is adopted for some aneurisms, removal of hairs, etc.

3. Both poles are in close apposition, but do not penetrate the skin or mucous membranes. This method is used by Apostoli for uterine fibroids; and in modified forms by others for strictures.

### General Requisites for Electro-Surgery.

These are a suitable switch-board attached to the main, or an ordinary galvanic battery of Leclanché, or other cells (large size preferable—for a portable battery, the Hellesen or other dry elements); a collector and current reverser; a milliampère meter reading to 150 m.a. for ordinary work, and to 300 m.a. for Apostoli's method; a rheostat, rheophores, a large indifferent electrode, and others of special shape for Apostoli's method, as well as for treatment of the urethra, lachrymal duct, Eustachian

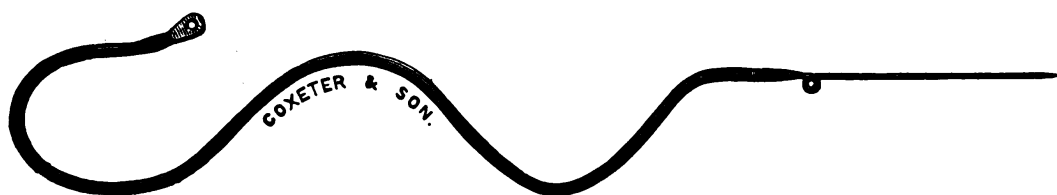

FIG. 118.—ELECTROLYSIS NEEDLE.

tube, and the œsophagus; needles of various sizes of platinum, gold, and steel (their stems should be insulated by vulcanite sheaths to avoid injury to the skin, though painting with ordinary shellac will be sufficient, provided it be renewed after every application). The needles should be provided with arrangements permitting of their being attached together to the same rheophore (Fig. 118). The needle attached to the positive pole becomes decomposed by the current, but platinum and gold are less affected by this oxidation process than are other metals, and they are therefore usually chosen for this purpose, unless the caustic and hæmostatic effects of the salts of iron are desired. It is difficult also to give a platinum needle anything like a stable fine point, and its introduction is therefore more difficult and painful than is that of a steel one.

### Removal of Superfluous Hairs.

This is an operation that is easily and rapidly performed. Four to six cells of an ordinary galvanic battery (5 m.a.) are required ; an electrolysis epilation needle with a make and break key on the handle (Fig. 119), and a pair of epilation forceps.

The patient should be comfortably seated, or reclining in a good light. Place a medium-sized, well-moistened pad electrode attached to the positive pole over the sternum, and secure the kathode to the electrolysis needle. Grasping the hair in the epilation forceps, press the needle-point down for about  $\frac{1}{8}$  inch into the hair follicle beside the hair. Make the current for a few seconds, a few bubbles



FIG. 119.—EPILATION NEEDLE-HANDLE.

of gas will escape, and the hair can be lightly drawn out. A stinging pain is felt during the passage of the current, but an anæsthetic is never required. About fifteen to twenty hairs can be removed at a sitting. A 20 per cent. ointment of cocaine can be applied afterwards to soothe any irritation. A small red spot marks the site of each operation for a few days, but no scar results. The Röntgen rays may also be made use of to remove the finer hairs, but must be used with great care.

### Trichiasis.

Ingrowing eyelashes can be successfully removed in the same way.

### Small Tumours and Warts.

The small fleshy and pendulous tumours can be readily and almost painlessly removed by introducing into them a needle connected with either pole. The positive pole is

slower in action, but less likely to cause a scar. A current of 3-7 m.a. may be passed for two or three minutes. If the negative pole be used, the fleshy mass will swell up, and bubbles of gas will rise round the needle. No haste in repeating the operation should be displayed, for the tumour will continue to shrink for some little time.

Warts can also be similarly electrolyzed and destroyed, but the operation is a painful one, and they usually return quickly. They may be treated by the Röntgen rays.

### Nævi.

Not much, unfortunately, that is worth the doing can be done by electrolysis for cutaneous nævi and port-wine stains (*vide* Röntgen rays and high frequency currents), and other nævi on the scalp or on covered parts of the body are more rapidly dealt with by the ligature or knife; but for subcutaneous nævi on the face, or in complicating situations, electrolysis is the best treatment, because it causes the minimum amount of scarring, and is most easily directed and localized. The old method was to pass one needle only into the nævus and to connect the other pole to a large indifferent electrode; the modern method is to pass into it several needles attached respectively to both poles; or if only two needles be inserted, to move one of them about. The operation is in this way very much shortened.

### Requisites.

An ordinary galvanic battery of from 10 to 40 cells (if possible of large size), Leclanché or Hellenes; if bichromate, or if Bunsen cells be used, a smaller number will suffice. A milliampère meter, rheophores, and needles; the latter may be of platinum, steel, or gold; they should be insulated, except close to the point, so as to avoid destroying the skin. Coxeter makes a convenient form of needle-holder for fastening the needles to. Dr. Jones has devised a bipolar fork electrode (Fig. 120) so arranged that several needles alternately positive and

negative can be screwed into it. By this means the needles can be kept at equal distances from each other, and cannot come into contact, however moved about. Two assistants are required, the one to administer an anæsthetic, and the other to watch the milliampère meter and manipulate the cell collector.

All being in readiness, the needles, if separate, are introduced one by one with a slight twisting motion, and the current turned on, and gradually increased to from 60 to 100 m.a.

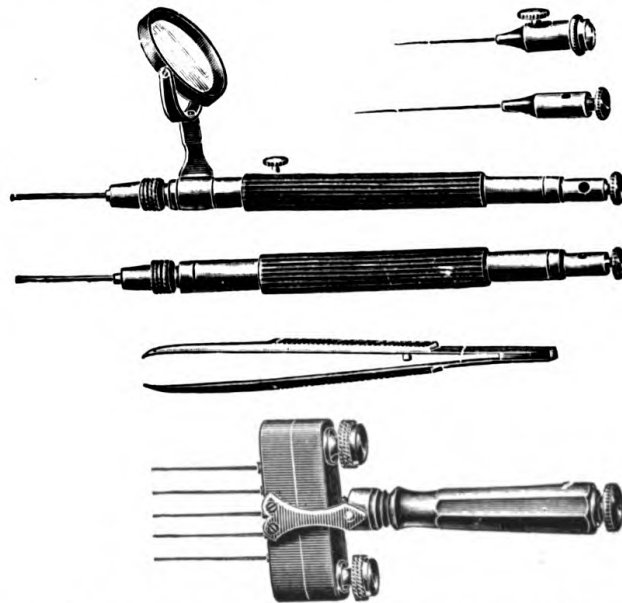

FIG. 120.—LEWIS JONES' AND OTHER EPILATION NEEDLES. !

The assistant should watch the galvanometer carefully to prevent any short-circuiting from the needles accidentally meeting in the nævus; this would be indicated by a sudden great increase in the current-strength, and is remedied by slightly displacing the various needles until the short circuit be broken.

As the current passes, the tissues round the needles change in appearance and texture; bubbles of gas are formed round the negative needles, and the tissues soften and swell; a hardening and contraction occur round the positive needles. The skin around the nævus becomes



hyperæmic. As the tissues are seen and felt beneath the finger to change, the needles should be one at a time withdrawn, and reinserted in other parts, so as to distribute the decomposing and cauterizing effect.

When every part of the tumour has been attacked, and a doughy induration produced, the current should be gradually reduced to zero, and the needles slowly withdrawn; the negative needles will be found to be quite loose, and the positive somewhat firmly fixed. If any difficulty be met with in withdrawing the latter, some hæmorrhage may follow; it is better, therefore, in such cases, when the current-strength has been sufficiently reduced, to temporarily reverse its direction; this will immediately loosen them. The time the operation will last depends upon the size of the nævus, and upon the current-strength and number of needles employed; most cases can be completed within fifteen minutes. Dr. John Duncan preferred to use two needles only; he kept the positive one fairly steady, and he moved the negative one about in all directions, so as to cauterize every part of the tumour.

In certain cases, where the smallest possible amount of scarring is desirable, it may be well to introduce the positive needle only, the negative pole being attached to a pad on the sternum; this considerably prolongs the treatment required.

The operation may require repetition, but plenty of time should be allowed for the nævus to undergo the retrogressive changes set up. The after-treatment is simple; the punctures may be painted with collodion, and the part kept at rest with a pad of absorbent cotton, and a bandage.

### Goitres.

The vascular and soft varieties are those best adapted for treatment by electrolysis; but all kinds, even the cystic and exophthalmic, may be thus treated and often benefited (J. Duncan). They should be treated like nævi,

but with only two needles introduced ; the latter should be of platinum or steel, and should be plunged in at the equator, so as to avoid the thyroid vessels. The positive needle may be kept fairly steady, but the negative one should be moved about. Large active cells are best—accumulators, Bunsen's or Hellesen's; the current-strength may go up to 100 m.a. The late Dr. John Duncan has by this method had excellent results.

Dr. Kuttner, of Berlin, prefers to introduce the negative needle only, because its destructive action is more intense and complete, and the necrosed products are more rapidly absorbed ; the absorption of the hardened and acidly cauterized products of the positive poles is much lower. He places one or two negative needles in the tumour, a large positive electrode over the sternum, and passes a current of 60 to 70 m.a. for ten or twelve minutes. The operation is repeated every two or three days. Of nine cases so treated, two were completely cured, and five greatly ameliorated. Cases in which laryngeal pressure is prominent are quickly relieved.

#### **Cirroid Aneurisms.**

These should be treated in the same way. They are very amenable to electrolysis, and can always be cured by it. Two or three séances may be required.

#### **Aneurism by Anastomosis**

is not so amenable to electrolysis. If, however, of small size, it may be successfully treated. The method of treatment is the same as for goitres.

#### **Aneurisms.**

Many attempts have been made to utilize electrolysis in aneurisms, especially in those thoracic ones that are not amenable to ordinary surgical treatment ; it has been hoped that the clotting which occurs around the poles might serve as a nucleus for further coagulation and

deposits of fibrin, and that the aneurism cavity might in this way become partially filled up.

Such attempts have not met with much success. Cini-selli treated thirty-eight cases by the introduction of needles connected with both poles, and by reversing the direction of the current every five minutes; of these twenty-seven were ameliorated, but none cured.

Dr. John Duncan attained the most favourable results in popliteal, femoral, and axillary aneurisms; sixteen out of twenty-nine of these were cured, only six out of thirty-seven in the aortic variety.

Dr. Petit, in the 'Dictionnaire Encyclopédique,' gives the following statistics: Of 114 cases of aneurism of the aorta treated by electrolysis, 68 were improved (*i.e.*, 59 per cent.). In aneurisms of the extremities complete cure is the rule.

Various methods of utilizing electrolysis have been adopted.

In the unipolar method one pole only was introduced, and the other was connected with an indifferent pad placed in the vicinity. The difficult question was which pole to introduce. The positive pole gave the best and firmest clot, but, being difficult to withdraw, sometimes led to hæmorrhage, or even to rupture of the vessel. The negative pole gave a large, unsubstantial and frothy clot, largely made up of hydrogen bubbles, which was not only of little value in setting up a stable coagulation, but was thought to be dangerous from the risk of emboli. Then, when both needles were introduced, the greatest precautions were taken to keep the exposed part of the needles well in the middle of the blood stream, and not to cauterize the wall of the sac, and this because there is risk of:—

- (a) Hæmorrhage from the needle punctures.
- (b) Inflammation of the wall of the sac.

Dr. John Duncan had recently been treating cases on an opposite plan. Believing that these precautions have been rather overdone, and that good rather than harm might result from a somewhat freer use of the

needles, and being of opinion that in our fears of hæmorrhage and suppuration we were not taking all the advantage we might of the current, he made a practice of from time to time gently moving the positive needle about in the sac, so as to bring its point into contact with, and to slightly cauterize, various parts of the sac wall. Roughenings are produced by these means, which form further nuclei for the deposits of fibrin.

### Indications for Electrolysis.

Electrolysis is indicated chiefly in those thoracic and subclavian aneurisms in which medical treatment has failed, and in which the only other alternatives are the distal ligature, amputation at the shoulder-joint, or the introduction of coagulants ; even though there be danger of external hæmorrhage, the operation is still indicated, for electrolysis checks the hæmorrhage.

### Method of Procedure.

A battery of twelve or more large Leclanchés, five to eight Bunsens or accumulators, or a suitable switch-board, a milliampère meter, rheostat, rheophores, and two long needles carefully insulated in their stems, are required.

The patient should be kept absolutely quiet, both during, and for some time after, the operation.

Both needles should be inserted (more than two needles add complexity and the risk of after-hæmorrhage without corresponding advantage ; the unipolar method does little good unless very strong currents are used). When the needles are *in situ*, the current should be gradually turned on, the patient being carefully watched for any signs of faintness ; if all go well, the strength of the current may be brought up to from about 20 to 30 m.a. as the limit. The positive needle may now be gently moved so as to touch and slightly cauterize the sac wall in one or two places. After a séance of from ten to twenty minutes, the current may be gradually cut off, and the needles then withdrawn ; if the positive needle

sticks, the current can now be temporarily reversed to disengage it; except for this, it should throughout the operation be steadily maintained in the one direction.

### Dangers of the Operation.

Hæmorrhage, inflammation, and embolism.

Hæmorrhage from the point of puncture can be avoided by passing the needle through the thickest part of the wall of the sac, by having its stem well insulated by vulcanite, and by cutting off the current before withdrawing the needles, so as to avoid cauterizing the track of the wound.

Inflammation of the sac wall and suppuration of the track of the needle are rarer occurrences; the latter may lead to a fatal hæmorrhage, as in a case reported by Dr. Henry Simpson. Rigid antisepsis and complete rest after the operation are the best preventives.

Embolism apparently need not be feared; no case of it, to the author's knowledge, has ever been reported.

### Results.

If the operation be successful, the tumour hardens and shrinks, and may occasionally be wholly cured; further, any tendency to external hæmorrhage is temporarily arrested. Commonly, there is some flattening down of the tumour, with relief from the pulsation and pain.

After a few days' rest the operation may be repeated.

The resistance of the blood in an aneurism has been stated by Bartholow to be about 8 ohms; my reasons for doubting this have already been mentioned. Dr. John Duncan, using six Bunsen cells, has rarely obtained a current of 70 m.a.; supposing, however, that 100 m.a. were obtained, then, as by Ohm's law (disregarding polarization, which, at any rate, cannot be very effective in a moving stream),  $R = \frac{E}{C}$ .

Then  $\frac{2 \text{ volts} \times 6}{0.1 \text{ ampère}} = \frac{12}{0.1} = 120 \text{ ohms.}$

which is approximately the resistance the current is encountering, and allowing 20 ohms for the resistance of the galvanometer, etc., this would leave about 100 ohms as the resistance in the aneurism; but, of course, very much will depend upon the distance the needles are from each other, the number of needles inserted, the amount of the stem uninsulated, etc.

The late Dr. John Duncan was kind enough to write to me the following letter in regard to the results of his twenty-six years' experience in electrolysis :

' In aneurism, within the last two years, I have made a new departure, which, I think, promises well. I had found that, while electrolysis might be used with complete success in small external aneurism, and in attacking the secondary sacs of aortic aneurism, I did not obtain with it those occasional brilliant cures which had, in the hands of others, been observed. In taking away the risks of hæmorrhage and inflammation of the sac wall, which had formerly prevailed, I had also greatly diminished the curative power of the agent. In short, I came to see that the cure had been in most cases due to the very cauterization of the sac which had been thought to be so dangerous. I had no deaths, but none of the old sudden cures; I had trusted for cure to the coagulation, the effect of which is slight, and had eliminated cauterization.

' I determined, therefore, about three years ago, to gently cauterize with the positive electrode the inner wall of the sac, and I have now had two very satisfactory results by this method, which I hope to publish when they are completed.

' In cirroid aneurism, which I define as a tumour composed solely of enlarged arteries (most common on the temporal), further experience has confirmed what I long ago stated, that no other method of treatment approaches electrolysis in safety and certainty. I have cured every case I have seen.

' It is different with angiomas, in which metamorphosed capillaries, veins, and arteries are all involved. In

some of them I have failed to bring about a cure, generally because of their size or situation, although in the majority I have been perfectly successful.

‘In the subcutaneous and mixed forms of nævus, when they are situated on parts of the body where a scar is to be avoided, electrolysis is the safest and most certain of all our remedies ; but in port-wine stain it is useless, unless you are prepared to leave a scar, and in those portions of the body on which a scar is of no moment, excision is much more rapid.

‘In aneurism I include in the circuit a galvanometer and rheostat, and use not more than 20 to 25 m.a. In the angiomata generally these precautions are less necessary. Anything from 20 to 80 m.a. will do, and you judge by the effect on the tumour in doughy induration and swelling, and especially avoid producing any alteration of colour in the skin.’

## CHAPTER II

### STRICTURES

ELECTROLYSIS has been successfully used for stricture of the urethra, rectum, Eustachian tube, œsophagus, and lachrymal duct.

That stricture of most kinds can be safely and pleasantly removed by the local cauterizing and decomposing action of electrolysis cannot be doubted ; the main reason why it is not more generally adopted is the comparative slowness and expense of the method. The misuse of electrolysis by those inexperienced in electrical apparatus, the strong currents employed, with their sometimes serious results, and the rash advocacy of enthusiasts, have also created a prejudice against it.

When a urethra can be dilated by readier and simpler means in much less time, and without the special knowledge or apparatus that electrolysis requires, few surgeons will be found to prefer the latter.

It has, however, certain advantages. It is, when properly administered, safer, because there is no bruising or sudden stretching of the tissues ; it is less painful—no anæsthetic is ever required or should be given ; the patient will rarely complain of anything but a slight tingling or pricking ; there is no hæmorrhage, and there is, for all these reasons, less shock or chance of subsequent rise of temperature. It has been stated that antiseptics are not required, because the process itself is aseptic ; but this can scarcely be the case, for we saw (p. 181) that the negative pole, the one always used in urethral electrolysis,



has no antiseptic action at all. Rigorous antiseptic precautions are as much required in this as in any other operation on the urethra.

### Stricture of the Urethra.

Requisites: A switch-board, a battery of ten Leclanché or other cells, a milliampère meter, rheophores, an indifferent pad electrode, and a case of different-sized urethral bougie electrodes (Fig. 121).

The latter should be of gum elastic, with olivary-shaped nickel-plated ends; as the negative pole is the only one used internally, platinum is not necessary. A wire passing

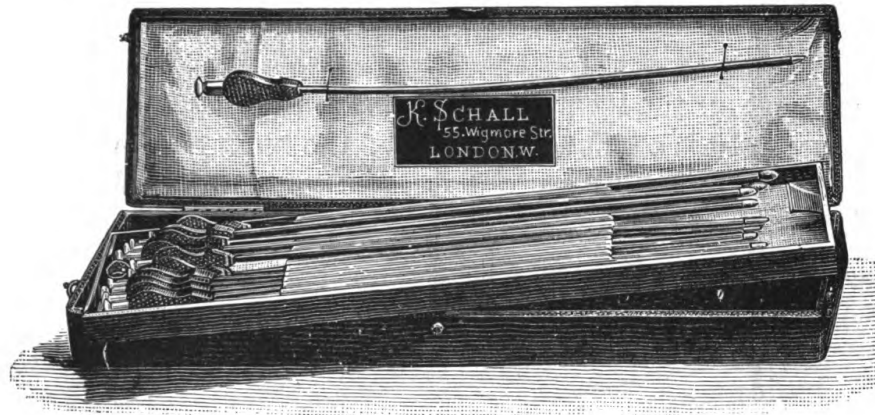

FIG. 121.—CASE OF URETHRAL ELECTRODES.

along, and insulated by the stem of the electrode, connects the exposed olivary-shaped end with a terminal binding-screw.

### Mode of Procedure.

With the patient lying down with the indifferent pad, which should be attached to the positive pole of the battery, beneath him, the size of the stricture, and the distance it is from the meatus, should be ascertained by means of an ordinary bougie, proper antiseptic precautions being taken. An electrode, one or two sizes larger than the calibre of the stricture, should be chosen, and the distance it will have to pass to reach the stricture marked

upon its stem. It should now be gently passed along the urethra until it rests by its weight merely against the stricture, and should then be connected by means of the binding-screw and rheophore with the negative pole of the battery. By using the cell collector, the current is now turned gradually on, and brought up to between 3 and 5 milliampères ; a greater strength is not desirable, and would cause the patient pain ; the current should be maintained for about fifteen minutes, unless the electrode be previously felt to pass through the obstruction. The current being first turned off, the electrode may be withdrawn. Whether the stricture has been passed through or not, the symptoms due to it will be relieved, and the patient will be able to pass water more easily. A slight slough may follow the withdrawal of the electrode, or may appear at a later period. The operation may be repeated with a larger bougie in about a fortnight's time. The negative pole is selected for the reasons already mentioned under the treatment of goitre, viz., that it softens and dissolves away the tissues in a manner that allows of their ready absorption ; the positive pole hardens and dries them.

The operation is, with these precautions, and the weak current recommended, an easy and simple one, but as several séances are usually required, and as they should not be repeated oftener than about once a fortnight or so, a prolonged treatment is necessary.

### Results.

From the observation of numerous cases, the late Dr. Steavenson believed that electrolysis was one of the most efficient and satisfactory modes of treating stricture of the urethra ; there was no comparison, in his opinion, between the treatment of stricture of the urethra by ordinary methods and its treatment by electrolysis. Mr. Bruce Clarke allows three weeks to intervene between the sittings. If at the first sitting the stricture took a No. 4, in a fortnight or three weeks a No. 8 or 9 would pass ; in such a case treatment would begin again with a No. 10 bougie

electrode. Quoting from a table of fifty cases, he showed that twenty-three were known to be well after periods varying from one and a half to three years, and in two cases no relapse had taken place after four years, whilst only nine were known to have required subsequent treatment. At the meeting of the Medical Society, at which Mr. Bruce Clarke's paper was discussed, other surgeons expressed themselves as opposed to the treatment. Mr. Hurry Fenwick remarked that he had treated twenty picked cases of stricture of the urethra by electrolysis, and that they were all the worse for the treatment ; two of them had developed troublesome traumatic strictures, and the method was also one not without danger, for the electrode had been known to perforate into the rectum, to produce troublesome hæmorrhage, and to lead to a fatal issue at least in one case.

The fact that the electrode had in one case perforated into the rectum clearly shows that the urethral stricture had not been treated in a proper manner. With a current of 5 m.a. it would take days, unless manual force were exerted, to bore a hole through the intervening tissues. No one should attempt even such a simple electro-surgical operation as this without a proper knowledge of his apparatus, and without a galvanometer in the circuit ; nor should he entertain the idea that the best mode of procedure is straightway *coûte que coûte* to electrolyze a sufficiently large hole through the stricture.

Dr. Robert Newman, who introduced the method described, recommends the following precautions :

The use of very mild galvanic currents, just perceptible to the patient, and from three to five minutes in duration ; the use of the negative pole held loosely against the obstruction without pressure or force ; long intervals (from two to four weeks) between the applications.

Dr. Fort, of Paris, treats strictures by linear electrolysis (*Lancet*, August 23, 1890). He has operated on 700 strictures of the urethra without a single fatal result by this method. He uses the *electroleur*, an instrument in-

vented by him, which, by means of a linear exposure of metal, ploughs a narrow furrow through the obstruction ; the operation when properly done is innocuous, without pain and blood, and no bougie is afterwards required. The conclusions of Dr. Fort are as follows : Linear electrolysis may be used for all kinds of stricture. Owing to the simplicity and harmlessness of the operation, and owing to the greater infrequency of relapses by this method than by others, Dr. Fort considers that linear electrolysis should be preferred to urethrotomy, and ought to constitute the operation *par excellence* in the treatment of stricture of the urethra. Most operators prefer Newman's method.

#### Chronic Inflammation of the Urethra.

A gleet may often be benefited and caused to heal by judicious electrolytic cauterization. The position of the tender, unhealed, and discharging surface should be localized, and the exposed head of the bougie electrode used for stricture brought against it. The latter is attached to the negative pole, and a pad connected with the positive pole is placed over the lumbar enlargement ; a current of about 4 m.a. is passed for about four minutes, and the electrode gently moved up and down so as to attack the whole of the diseased area. The séances may be repeated about every ten days.

#### The Prostate.

Hypertrophy of the prostate may be treated by electrolysis or galvano-cautery. (Tripiér has used faradization.)

The electrolytic treatment resembles that of a urethral stricture. A special prostatic electrode, insulated except on the convex margin of its point, should be passed along the urethra until the exposed surface rests against the enlarged lobe (guided to the position if necessary by the finger per the rectum). It should be attached to the negative pole, and a current of about 5 m.a. passed for about ten to twenty minutes. The operation may be repeated in about a fortnight.

The result is to cauterize and dissolve away portions of

the obstructing tissue. It is needless to add that this is a far safer operation than that with the galvano-cautery. Morotti recommends Bottini's thermo-galvanic cautery (*British Medical Journal*, May 23, 1891). An instrument is used which combines both an incisor knife, a cautery of small platinum plates, and tubes for the circulation of water : a cautery battery of accumulators or bichromates is required.

The operation consists in passing the instrument with the patient in the lithotripsy position. When the point is in the bladder, it is turned downwards and gently drawn forwards so as to cause the beak to hitch against the prostate, and bring the cautery in contact with the part on which it is desired to act. If there is any doubt, the exact position of the instrument should be ascertained with the finger in the rectum. The current is now turned on, and the point pressed against the hypertrophied tissue, while a stream of cold water is made to circulate through the instrument. By gently elevating the handle of the instrument the point is made to burn its way slowly through the prostate. When the sound of burning is distinctly heard, the point should be gently moved backwards and forwards, until the projecting lobe is completely divided. When it is judged that sufficient tissue has been destroyed, the current should be shut off, but the instrument should be left *in situ* for two or three minutes, so as to allow it to become cool before it is withdrawn. The knife should next be restored to its sheath, and the instrument pushed into the bladder, so as to make sure that it is not caught anywhere, and then withdrawn. For the after-treatment, if the patient cannot pass water in the natural way, Nélaton's soft catheter should be used. The eschar usually separates from the tenth to the fifteenth day.

Professor Bottini has operated in this manner in fifty-seven cases with two deaths, in thirty-two cases with a perfect cure, in eleven with improvement, and in twelve with no result.

The method is not altogether free from danger unless the greatest care is used, and it should be reserved for cases in which strangury is persistent.

Dr. Newman also prefers the galvano-cautery.

Dr. Casper, of Berlin, employs electrolysis by galvano-puncture. A needle electrode insulated except at its point, and connected with the negative pole, is pushed into the prostate from the rectum; after a few minutes it is partly withdrawn and passed into another part of the gland, and after a second interval into another part. A current of from 10 to 25 m.a. is employed, and maintained altogether for about fifteen minutes. If the current does not exceed 15 m.a. the operation is not a painful one. Frequent repetitions (about every ten days) are required to insure a complete cure. This occurred in two out of four cases so treated, but in a third a recto-vesical fistula was produced. The strictest antiseptic precautions are required. By this operation holes are bored into the hypertrophied tissue, and their walls then cauterized and disintegrated; the result is to set up so many foci of necrosed matter, by means of which, through the ordinary processes of absorption, cicatrization, and contraction, the gland becomes much reduced in size.

### The Rectum.

Non-malignant strictures, especially if of syphilitic origin, may be treated successfully by electrolysis. A suitably-shaped bougie electrode, insulated except at its olivary-shaped head, one or two sizes larger than the calibre of the stricture will admit, should be chosen. It should be attached to the negative pole, and the method is the same as that for urethral stricture, except that the results are more rapidly attained, because stronger currents (10 to 20 m.a.) and more frequent repetitions (every four days) can be borne. The current may be kept up for twenty minutes, and no anæsthetic is required. Dr. R. Newman, whose method is the one described, after

an experience of fourteen cases, has come to the following conclusions :

In the treatment of strictures of the rectum electrolysis is not a panacea.

On the contrary, it may be unsuccessful, especially in carcinomatous strictures. Electrolysis will often succeed in those rectal strictures in which all other methods have failed.

A certain proportion of cases can be better cured by electrolysis, and with less fear of a relapse, than by other methods.

The fibroid strictures due to old inflammations offer the best chances of success.

Hæmorrhoids have been treated by the introduction of

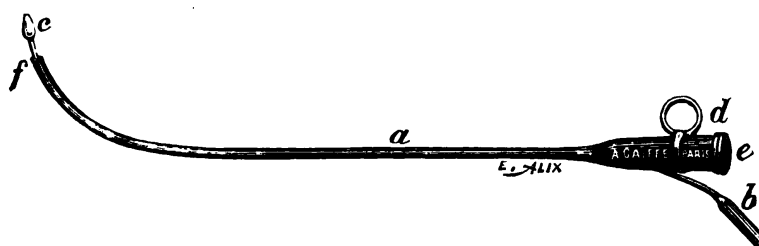

FIG. 122.—EUSTACHIAN CATHETER.

a needle attached to the positive pole ; this coagulates and dries up their contents. The electrolytic treatment does not offer any particular advantages, and high-frequency currents are to be preferred.

### The Eustachian Tube.

Successful attempts have been made to relieve strictures of the Eustachian tube by electrolysis. An electrode made to slide in the ordinary Eustachian catheter (Fig. 122), and attached to the negative pole, is used ; the catheter having been introduced in the ordinary way, the electrode is gently pushed along the Eustachian tube until the obstruction is met with ; the current is then turned gradually on (the pad attached to the positive pole may be placed on the nape of the neck or sternum), and brought up to about 3 m.a.

The patient will not experience any pain, but will hear a peculiar bubbling sound. The current should not be maintained for more than two or three minutes, and the electrode may, even before this time, have overcome the obstruction. Mr. Cumberbatch and the late Dr. Steavenson performed this operation a large number of times without any unpleasant experiences, or more than a little temporary discomfort to the patients. Mr. Cumberbatch, the aural surgeon to St. Bartholomew's, has written as follows as regards the operation: 'Our experience is at present too limited to be able to say what cases of chronic catarrh of the middle ear are most likely to be benefited by this new method of treatment. That strictures of the Eustachian tube, which do not yield to the ordinary methods, can be cured by the use of the electric bougie we have proved. In many cases of chronic catarrh with obstruction of the tube, there is no actual ankylosis of the ossicular joints, and in such a case restoring the patency of the tube, and thus relieving the pressure on the membrana tympani and the chain of ossicles, must act beneficially on the hearing, etc. In conclusion, I may add that if after three or four trials a patient experiences no benefit, the probability is that further treatment by this method will be useless.'

### Lachrymal Obstruction.

Mr. Jessop and the late Dr. Steavenson, in the *British Medical Journal* for December 24, 1887, recount ten cases treated electrolytically. The canaliculi are readily enlarged by a suitable probe electrode; for the nasal duct the probe should be insulated except near its point. In both cases the probe should be attached to the negative pole, and weak currents of from 2 to 4 m.a. used.

### The Œsophagus.

It has been suggested that strictures of the œsophagus should be treated electrolytically. The same general



method would be employed. More recently radium has been introduced into malignant strictures.

Growths and polypi in the nasal fossæ and naso-pharynx have been treated both by electrolysis and the galvano-cautery. Kuttner treated a case of hypertrophied tonsils by electrolysis. The left tonsil was cured after three, and the right one after five, galvano-punctures.

## CHAPTER III

### DISEASES OF WOMEN

#### Fibroid Tumours.

APOSTOLI states that chemical galvano-cauterization (electrolysis) can produce three principal results :

1. Arrest of pain.
2. Arrest of hæmorrhage.
3. Some diminution in the size of the tumour, together with relief from the pressure symptoms.

Further, as opposed to the previous attempts to make use of electricity in uterine tumours, he points out that his method is—

1. Precise, because he always measures the current-strength by a galvanometer.
2. Energetic, because he makes use of currents of great strength—50 to 250 m.a. For all that, it is
3. Tolerable, by reason of his large moist clay abdominal electrode.
4. Better localized, by direct application of the active electrode to the uterus, or to the substance of the tumour.
5. Thoroughly under control, because he both uses the unipolar method, and by means of proper apparatus can apply currents of any desired strength and duration.
6. More scientifically exact, from the due appreciation of the topical effects of the two poles.

Two main effects are claimed :

(a) Polar ; (b) Interpolar.

(a) The polar or tangible effect is a chemical cauteriza-

tion more or less severe, and different in character according to the pole used.

(b) The interpolar effect is that which results from the circulation of the current from one pole to the other. This action sets up a subsequent process of disintegration of the morbid products through which it is made to pass. (The interpolar action is somewhat obscure. *Vide* M. Weiss's experiments, p. 178.)

The positive pole is a hæmostatic more or less rapid in its action, and either direct or immediate, or secondary and remote. By it we can arrest hæmorrhage, either instantly, if the cavity of the uterus be of normal dimensions, if the action be relatively intense, and the hæmorrhage not excessive; or more deliberately and gradually after several applications, by the formation of contractile cicatrices. The 'positive' pole will therefore be the medicament *par excellence* in cases of 'hæmorrhagic' fibroids.

With the negative pole we produce a state of temporary congestion without direct hæmostatic effect. The interstitial circulation of the uterus will be hurried on, and a retrogression of the non-hæmorrhagic fibroids is the consequence either of this state of congestion or of the supplementary artificial and salutary hæmorrhages which take place. The negative pole will therefore be found to render invaluable benefit in those cases of fibroids accompanied with amenorrhœa and dysmenorrhœa, which are only too often the despair of both patients and doctors.

The 'positive' pole is the express remedy for the cases attended with 'hæmorrhage'; the 'negative' pole when they are not 'hæmorrhagic.'

As a supplement to these rules, viz., the positive pole intra-uterine for the restraining of hæmorrhage, the negative pole intra-uterine for tumours without hæmorrhage, comes the second indication for 'galvano-punctures.' These latter assume daily, as my experience increases, a more and more preponderating importance in my estimation.

The indications for galvano-puncture are twofold : first, as a matter of necessity in consequence of uterine atresia, or where there is such displacement of the organ as to prevent any introduction of a sound ; second, by preference when we see that we can advantageously combine punctures with intra-uterine cauterization, so as to expedite and make sure of the effects that, with the cauterization only, we should tardily, or, perhaps, imperfectly, realize. We must therefore undertake the galvano-punctures alone whenever the case will fairly admit of them, or use them in other cases as adjuncts to the intra-uterine cauterization previously tried.

What are the anatomical and clinical results of these procedures ?

As regards the ' material ' changes, we may affirm that every fibroid submitted to this treatment, sometimes after so short a time as one month, but certainly when the treatment is fully carried out, will undergo a manifest reduction appreciable by the touch and demonstrable by internal measurement. The further diminution of the tumour, which continues for some months, varying in amount from a fifth to one-half of the original volume, is generally associated with a coincident and equal accumulation of subcutaneous adipose tissue on the abdominal walls.

The liberation of the tumour from its local attachments takes place simultaneously with its decrease of bulk ; the tumour, which at the commencement of the treatment was immovable, can progressively be made more and more to change its position, as the absorption of the enveloping tissues deposited round it advances. The tumour also not only contracts in itself, but exhibits a tendency to separate itself from the uterus, to become more distinctly subperitoneal, to detach its mass, as it were, from its setting in the uterine wall, and to remodel itself into a pedunculated form.

The ' clinical ' results are not less striking. We may generalize the extent and importance of these results by

saying that ninety-five times out of one hundred they comprise the suppression of all the miseries constituting the fibroidal symptomatology, which may thus be categorically enumerated. Hæmorrhages, the troubles of menstruation, dysmenorrhœa, amenorrhœa, nervous disturbances, the direct pain in the growth itself, and from mechanical pressure, and the harassing series of reflex actions. In a word, the assertion may be safely advanced that though our therapeutical resources only carry us so far as the sensible reduction of fibroid tumours, and not to their total absorption, we may, with regard to the symptoms, certainly anticipate a complete removal, and the establishment of a state of health equivalent to a true resurrection. I am justified in saying that most women who have persisted in the necessary treatment, not only were cured, but remain well.

‘ Finally, I may lay down the following proposition : No operator should admit the failure of intra-uterine galvano-cauterization before having had recourse to galvano-punctures, which he must enforce either with or without anæsthetics.

‘ In the five years ending July, 1887, I have made 5,201 applications of the continuous galvanic currents on 403 patients for various gynæcological conditions ; of these I have only to deplore the loss of two, and of these two deaths I take upon myself the entire responsibility. My method was not in fault ; I only was to blame. Once there was a fatal error of diagnosis, a suppurating ovarian cyst being unrecognised, death resulting from peritonitis ; in the second case, a galvano-puncture was made too deeply. The consequence was intraperitoneal gangrene, for which the abdomen was not opened. In addition, I have to confess to having either excited or aggravated in the course of five years ten peri-uterine phlegmonous inflammations. These must be attributed to blunders in the carrying out of the treatment. During the five years there were 278 patients suffering from fibroid tumours, or hypertrophy of the uterus ; all these have not been cured,

because many did not persevere with the treatment ; but I can affirm that, when there has been no negligence, and my advice has been fully acted on, ninety-five times out of one hundred permanent benefit has been acknowledged ' (*vide* paper read by Dr. Apostoli at the British Medical Association, 1887).

So much for Apostoli's own account of his method and results down to 1887. When the author was in Paris, in April, 1892, he attended Dr. Apostoli's clinics, and observed that he was making much use of the alternating sinusoidal currents of M. d'Arsonval, also of electro-puncture, and apparently not so much of the simple continuous current. Dr. Apostoli had at that time not formed a definite opinion as to the efficacy of the sinusoidal currents, but the patients whom the author questioned all acknowledged that they had derived benefit from them ; the pain and leucorrhœa were lessened, and they slept and felt better.

The late Dr. R. Milne Murray, in the *Edinburgh Medical Journal*, January, 1902, makes the following remarks upon the present position of the Apostoli treatment :

' This is not the occasion to discuss at any length the ultimate value of Apostoli's contributions to gynæcological therapeutics, but I venture to assert my firm belief that, in spite of its inconvenience, its tedium, and its uncertainties, Apostoli's method would have been in general vogue to-day had it not been for the extraordinary success which, in the hands of experts, has attended the surgical treatment by hysterectomy of fibroid tumours. It is a much more expeditious procedure to extirpate the uterus and tumour by a single operation than to cure it symptomatically by electrical applications during two or three months—always supposing the patient does not die in the former case. But, on the other hand, there are multitudes of women suffering from the presence of a fibroid tumour who shrink from the suggestion of the knife, and refuse to submit to any surgical procedure. That a very

large number of these may be symptomatically cured by Apostoli's method does not admit of a doubt, and I do not despair of a time coming when a woman may have some choice between a proposal for a hysterectomy and the somewhat melancholy consolation to be derived from the assurance that very few women die from a fibroid.'

## CHAPTER IV

### REQUISITES FOR THE APOSTOLI TREATMENT

A SUITABLE switchboard or a battery of forty to sixty Leclanché, or persulphate of mercury, or thirty to fifty Hellesen cells, of large size, because the body resistance in the Apostoli treatment is much diminished (perhaps 100 to 400 ohms).

A cell collector capable of throwing one additional cell at a time into the circuit.

A good rheostat : Dr. Milne Murray's double tube liquid one, or an ordinary single tube liquid one containing water to which a few drops of milk have been added (*vide* 'Rheostats'). The single tube sulphate of copper solution rheostat scarcely presents sufficient resistance.

A milliampèremeter reading to 250 or 300 m.a.

A large 12 by 10 inch abdominal electrode. Apostoli recommends potter's clay. This is mixed up with water until a plastic, adhesive mass is formed, which is spread out in a layer about  $\frac{1}{2}$  inch thick on a piece of tarlatan. Upon this is placed a metal plate provided with a binding screw, and the muslin is folded over so as to enclose the clay. This electrode has the disadvantages of being troublesome to prepare, and of being cold to the patient. Dr. Franklin Martin, of Chicago, makes use of a nickel-plated concave plate covered with a membrane, and having an insulated rim to prevent contact between the metal surface and the skin. On the plate is a nozzle through which warm water can be poured, and which passes into the space between the membrane and the



concavity of the plate. This is easily prepared, is agreeable to the patient, and is clean. Dr. Milne Murray recommends a simple 12-inch pad of amadou thoroughly moistened with dilute salt solution; on this is placed a leaden coil like Leiter's, which both keeps it in position and conducts the current to all parts of the amadou. The flexible pillow carbon electrode, already mentioned, will

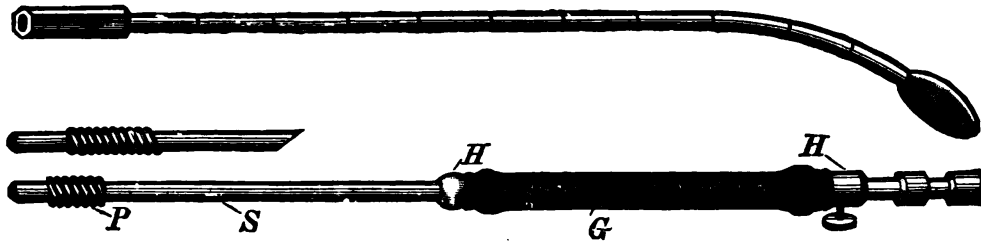

FIG. 123.—A UTERINE SOUND ELECTRODE.

also serve the purpose; it is cleanly, easily managed, and clings closely to the body.

A uterine sound electrode. The exposed end should be about  $\frac{1}{2}$  inch to 1 inch in length, and made of platinum, gold, or carbon; the stem may be made of copper, carefully insulated by vulcanite. Apostoli now uses gas carbon electrodes; a metallic stem, insulated by caoutchouc, bears a screw at one extremity, to which rods

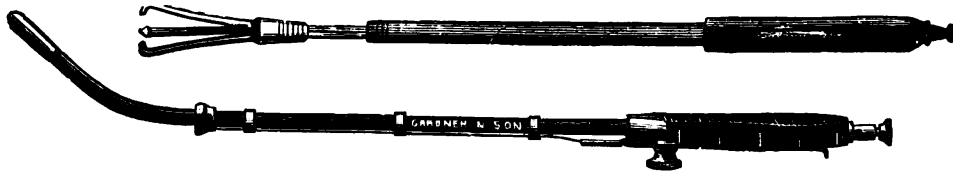

FIG. 124.—DR. MILNE MURRAY'S ELECTRODE.

of gas carbon, all 1 inch in length, but of different diameters, can be attached. The caoutchouc covering is marked with grooves at regular distances of 1 inch (Fig. 123).

For galvano-puncture a sharp-pointed steel trocar sliding in an insulating sheath of celluloid. If the positive pole be used to puncture with, the needle should be of gold (Fig. 125).

### Preparation of the Apparatus.

Connect the rheophore coming from the positive pole of the battery to one of the binding screws of the rheostat, and a wire passing to the galvanometer to the other (Fig. 126); let them be on a firm table; then attach a long wire intended to reach the uterine sound to the other terminal of the galvanometer. Let the rheostat be screwed

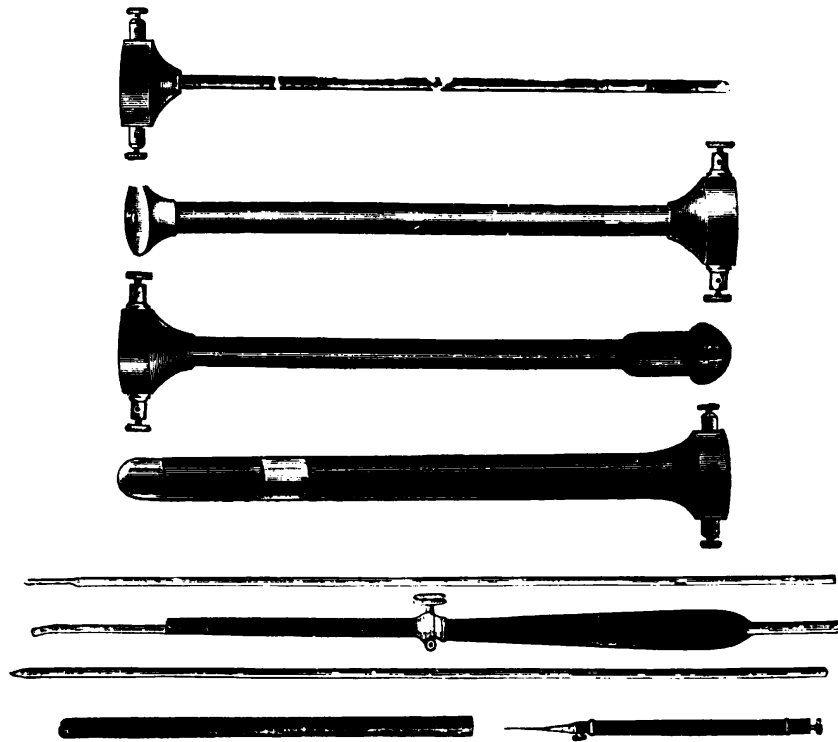

FIG. 125.—APOSTOLI'S ELECTRODES.

out to its full distance. Attach the other rheophore to the negative pole of the battery. Turn on all the cells, and plunge the ends of both terminal wires into a vessel of water, taking great care not to allow them to touch. Gas should now be pretty freely given off, and in much larger quantity from the negative terminal. This decides two questions—whether all the cells are properly connected and in working order, and which of the two wires is the

negative one. If the poles of the battery are not marked, and there should be any further hesitation as to the quality of the wires, a piece of litmus paper may be moistened, and the two wires made to touch it; the positive wire will turn the part it touches red. The collector may now be brought back to zero. Disinfect the uterine sound

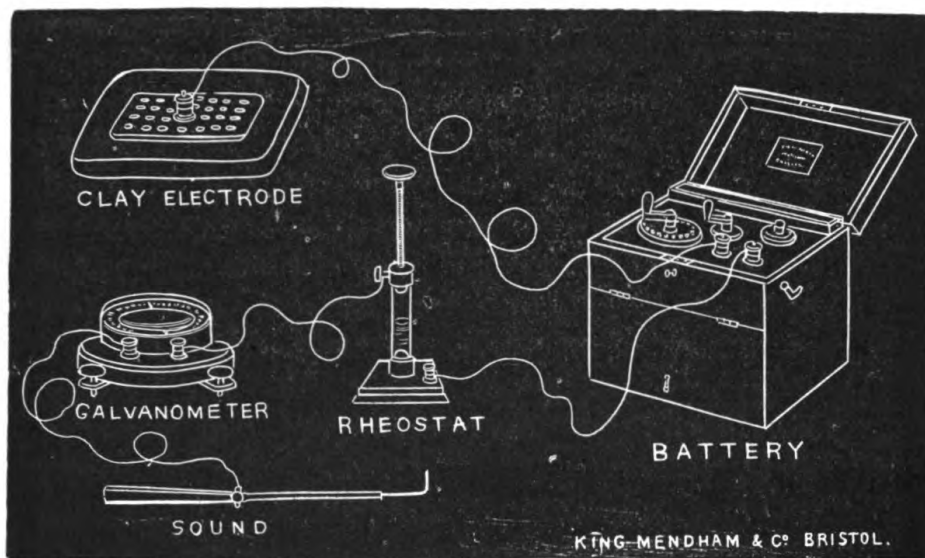

FIG. 126.—ARRANGEMENT OF APPARATUS FOR THE APOSTOLI TREATMENT.

electrode by passing its point through a flame, and then by placing it in a carbolic solution.

### Preparation of the Patient.

The patient should remove her corset and loosen her skirts; she should be assured that she will feel no pain or shock at all provided she will keep perfectly still, and that you will leave off at any moment should she desire it, but that she must not on any account move or rise until you give her leave. The intermenstrual period should, if possible, be chosen; but if serious bleeding be going on, the operation may be done at any time.

### The Operation.

Let the patient have an antiseptic douche. Place her in the ordinary gynæcological position on her left side on a firm couch ; let the nurse kneel at the opposite side.

Pass the sound, and then ask the patient to turn slowly on to her back, while the nurse holds the sound firmly. Bare the abdomen, examine it for any spot or abrasion, and cover them, if found, with collodion and a few threads of cotton-wool, or with oil-silk. Sponge the abdomen with warm salt solution, and apply the warm moist flannel or pillow electrode ; connect this electrode to the wire coming from the negative pole. Connect the wire from the galvanometer to the extremity of the sound. (The wire should be well insulated, and great care taken to prevent any exposed metallic part from coming into contact with the patient's thighs.)

Now gradually turn on the cells by the collector until the current has risen to about 30 milliampères ; pause a little, and then screw down the rheostat, until the patient begins to complain. If the patient will allow it, the current may be taken up to about 200 m.a. ; it should be maintained for about eight minutes, and then gradually cut off. A second antiseptic douche should follow, and the patient should then rest for a couple of hours or longer. The very greatest care must be taken to see that no interruption of the current occurs during the séance ; the binding-screws should be firmly screwed down on the wires, and a commutator on the battery avoided. The operation may be repeated once or twice a week, according to the condition of the patient, and the treatment should be persevered in until some twenty séances have been held.

During acute inflammations, especially if suppurative, this treatment is contra-indicated.

The operation described (positive pole intra-uterine) is of most use in hæmorrhagic fibroids, particularly if sub-mucous or interstitial ; if there be no hæmorrhage, it will probably be useless.

Apostoli recommends the negative pole intra-uterine, or galvano-puncture for non - hæmorrhagic fibroids ; the former should be preferred.

### Galvano-Puncture.

The preliminaries are the same as for the previous operation.

Chloroform is usually required.

The steel trocar should be attached as a rule to the negative pole ; but it may at the first séance be attached to the positive (less painful and destructive).

Apostoli gives the following principal rules (Bigelow, 'Gynæcological Electro-therapeutics') :

'Strict antiseptics both before and after. Use a very fine steel trocar.

'Never make a puncture in the anterior cul-de-sac. Confine it to a lateral or to the posterior cul-de-sac.

'Choose for the seat of puncture the most prominent point in the tumour found in the vagina, making it project more, if necessary, by directing an assistant to press it downwards from above the pubes. Make the punctures without a speculum. First fix in the celluloid sheath the needle to the depth of the puncture to be made ; then, having ascertained with the index-finger that there is no arterial pulsation, allow it to rest upon the point to be pierced ; then slide underneath this finger the celluloid sheath which is to carry the trocar until its open mouth shall rest upon the exact spot ; then push the trocar home, its penetrating depth having been properly adjusted. Make without exception only superficial punctures, not more than  $\frac{1}{2}$  centimetre, or at most 1 centimetre deep, so as not to cause any central gangrene, and to admit of an incessant antiseptic treatment.

'The strength of the current may be at first from 20 to 50 milliampères. Second or third punctures may be made if desired.

'Let the patient have an antiseptic douche afterwards,

and then pack the vagina with iodoform gauze. The patient should remain for one or two days in bed after a séance.

‘Repeat the operation only at the end of a week or fortnight, so as to avoid accumulations of fœtid matter ; suspend the séances temporarily if there are any threatenings of fever.’

That this is a much more serious operation than the former is evident. The bladder and rectum have been perforated, permanent fistulæ set up, large bloodvessels wounded ; but the great risk is, of course, that of sepsis.

The operation of galvano-puncture has as a consequence been practically abandoned. Pediculated roving fibroids in the abdomen are unsuitable for Apostoli’s method, for it would be impossible to reach them with a sufficient current density.

### Endometritis.

Cases of chronic endometritis may be treated by intra-uterine applications of the negative pole (the positive if there be much hæmorrhage). The procedure is much the same as that for fibroids, but the electrode should be moved about in the uterus in such a way as to leave no part of the diseased mucous membrane uncauterized. The strength of current may be from 100 to 200 m.a., and the duration about five minutes. Half a dozen séances may be sufficient to effect a marked improvement.

Dr. Playfair remarks : ‘In the treatment of certain morbid conditions of the endometrium, especially chronic endometritis, etc., I have found the application of the negative current through the insulated intra-uterine sound produce far more uniformly good effects than any other form of intra-uterine medication with which I am acquainted. I am quite satisfied that there is nothing to compare with it in these very troublesome cases, many of which had lasted for years, and resisted every kind of treatment previously used.’

**Obstructive Dysmenorrhœa,**

if due to stenosis of the cervix, may be relieved by enlarging the os with the negative pole; the operation resembles that for other strictures, but stronger currents—15 to 30 m.a.—can be used.

**Membranous Dysmenorrhœa**

can be treated in the same way as endometritis.

**Menorrhagia and Metrorrhagia.**

Hæmorrhages of all kinds, whether dependent upon fibroid tumours, subinvolution, endometritis, retained abortions, etc., may all be relieved by the use of the positive pole.

**Malignant Tumours.**

Electrolysis has been proposed and tried for these. It effects some local destruction, and sometimes relieves the pain. Except when other more radical surgical operations are inadmissible, it is not to be recommended.

More recently the author has used both the X rays and high-frequency currents in malignant disease of the cervix. Some benefit has always resulted. High-frequency currents applied by a condenser vaginal electrode are to be preferred.

**Extra-uterine Fœtation.**

Electrolysis has been used to kill the fœtus and check the growth of the tumour (*vide* report of several successful cases, Beard and Rockwell, p. 630).

Faradism has also been used. The method is unreliable and dangerous; the latter for two reasons: inflammatory and septic processes may follow the electrolysis (*vide* Dr. Percy Boulton's paper in *British Medical Journal*, April, 1887). The treatment, moreover, by taking up valuable time and postponing more effectual measures, is endangering the patient's life.

PART V  
*ELECTRO-THERAPEUTICS*

CHAPTER I

**PRINCIPLES OF ELECTRO-THERAPEUTICS**

THE principles of electro-therapeutics rest more upon an empirical than upon a physiological basis, and though we have the records of more than a century to guide us, yet these were, until the last few years, deprived of much of their value from the want of scientific measurement and dosage.

The therapeutic uses of medical electricity may be taken to be broadly founded upon three chief groups of effects :—

- (a) Stimulating.
- (b) Sedative.
- (c) Trophic.

(a) The stimulating effects are especially yielded by static and faradic electricity, or by galvanic, if the current be interrupted or reversed. To obtain local stimulation of the motor and sensory nerves, the muscles, and the skin, we employ static sparks, the faradic and interrupted galvanic currents ; for the unstriped muscles and nerves of special sense, the interrupted galvanic or sinusoidal currents.\*

\* Treatment by high-frequency currents will be considered in a later chapter.



As a general stimulus, the static bath (with or without sparks), general faradization, and faradic baths may be used.

(b) Sedative effects may be obtained from static and galvanic electricity.

To produce a general effect, we employ the static bath of short duration (five to ten minutes).

To produce a local effect, the static breeze (*souffle*) and the anode of the continuous galvanic current are desirable.

(c) Trophic Effects. All forms of electricity, but especially the galvanic, have been credited with nutrition-modifying and encouraging powers. It would, however, appear from M. d'Arsonval's researches (*vide* 'Electro-Physiology') that a continuous galvanic current possesses no such properties, at any rate on the general system, when in health. On the other hand, the static bath and alternating currents of all kinds, especially those that are sinusoidal, do exhibit these effects, which we may perhaps ascribe chiefly to nervous stimulation, whether that is accompanied by obvious muscular contractions, or whether it consists in a gentle and imperceptible exercise of the sensory and other nerves, which, by influencing the central ganglia, reflexly affects the whole system.

Locally, no doubt, the constant galvanic current produces certain nutritive changes, but these are confined to the poles, and are of an essentially destructive nature; acids and alkalies formed out of the decomposition of the tissues are liberated beneath the electrodes. If the galvanic current be interrupted, then those properties that depend upon stimulation would come into play.

### Static Electricity.

The description of the apparatus and of the general method of its employment have already been given (p. 11). Fig. 127 represents the chief forms of the electrodes; they are so arranged as to respectively fit one metallic handle, which bears a ring for the attachment of a chain.

Fig. 128 represents an insulating stool ; the body may be made of wood or of glass, but the legs must consist of glass, earthenware, or ebonite. They should be fully 6 inches long. An indiarubber mat for the legs to stand

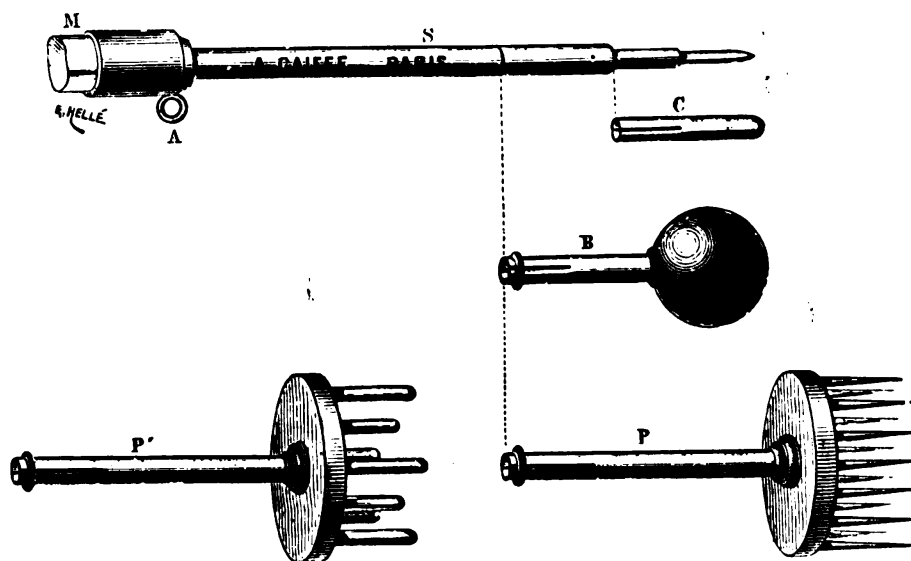

FIG. 127.—ELECTRODES.

on is an additional advantage. A thick copper tube with a hook at one end and a ball at the other is perhaps the best conductor for forming the connection with the machine ; the ball may either rest upon the stool, if it be of wood, or in the hand of the patient, if the machine be not a powerful one. Care must be taken not to ap-

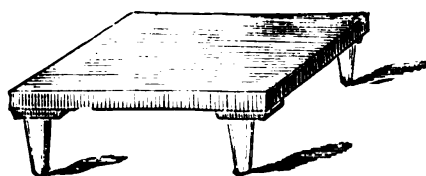

FIG. 128.—INSULATING STOOL.

proach the patient accidentally during the working of the machine ; at the close of the séance place the foot upon the stool to discharge it.

In the electrical department of the Salpêtrière Hospital,

in Paris, static electricity is chiefly used for therapeutical purposes, faradism very much less, while galvanism serves only as a diagnostic agent. At one end of the room are two large Wimshurst machines, enclosed in glass cases, in which saucers of calcium chloride are kept. The machines (double plate) are driven by straps, which pass out beneath the glass cases to two motors, which are driven by a current brought from a distance. Opposite each machine is a row of stools, standing upon platforms provided with glass legs, which rest in earthenware saucers; round each saucer is a ring of gas-burners, which can be lighted during damp weather. Two copper or brass tubes connect the rows to the machines; the other poles of the machines are free, and not connected with the ground. In the Edinburgh Royal Infirmary the free pole is connected to earth. The patients, of whom there are a great number, are treated in batches of about twelve. When a séance is to begin, the connecting tube is taken off, and the patients step up on to the platform and seat themselves; the tube is now put into position (connected to the positive pole), and the patients become charged. An assistant passes slowly in front of them, holding, by an insulated handle, a metallic conductor, connected by a chain with a strip of metal laid in the floor. From some of the patients he draws sparks by placing a ball electrode upon the conductor; others he treats with the breeze, and others have the bath alone. A séance lasts about fifteen minutes.

Apart from the therapeutical advantages which static electricity may offer (p. 154), there are certain conveniences in its employment; thus, the patient need not remove any part of the clothing, the skin has not to be moistened, and the whole operation is very quickly carried out. On the other hand, unless a motor be used (driven by the current from the main—batteries for such a purpose would be found costly and unsatisfactory), an assistant is required to turn the machine, and difficulties may be met with in making the machine work in wet weather

(they refused for more than half an hour upon one occasion to work when the author was at the Salpêtrière); with the new large multiplate machines the weather difficulty is almost removed. The apparatus, moreover, is essentially non-portable.

### **The Static Bath.**

The patient is placed upon the insulated stool, and is connected preferably with the positive pole of the electrical machine. This, speaking generally, has a sedative action if of short duration (five to ten minutes), calming nervous excitement and promoting sleep, and a stimulating one if of longer duration; in both cases the appetite is improved, depraved nutrition corrected, and a general tonic effect produced.

### **Indications.**

Low and debilitated states of the system, particularly of the nervous system, neurasthenia, overwork, hypochondriasis, melancholia, insomnia (patients constantly sleep more profoundly and for a longer time after two or three séances), dyspepsia, anæmia, etc.

The positive pole is less stimulating than the negative, and should be the first to be tried in cases of nervous excitement.

### **The Electrical Breeze, or Souffle.**

To the patient, seated as before, a pointed metallic conductor connected with the gas or water pipes or the free pole of the machine is presented at a distance of about 4 inches.

This possesses a remarkably sedative effect—one of the same nature as the anode in galvanic treatment, but far more energetic. If presented to the head in persons suffering from neurasthenia, it quickly relieves them of their habitual feelings of embarrassment, weight, pressure, and painful tension (Vigouroux). I have found it

of much benefit in obstinate cases of sciatica, in neuralgia, and in headache.

### Indications.

Neurasthenia, all local painful conditions, neuralgia, sciatica, painful joints, rheumatic conditions, and insomnia ; in the latter case a metal cap furnished with points is sometimes applied to the head. More recently I have used the breeze in the treatment of lupus and rodent ulcer with success.

### Electrical Sparks.

A wooden or metallic ball connected with the ground is brought close enough to the patient to cause discharge of sparks.

This has a markedly stimulating and tonic effect upon the general system. Reddening of the skin, developing into slight weals, with tingling and slight burning sensations, and muscular contractions, if the sparks be strong, and be drawn from over the motor points, are produced ; the deeper structures are also affected.

### Indications.

Electrical sparks are used as a further stage of treatment in neurasthenia, in hysteria, neuralgias, paresis or paralysis of the muscles, anæsthesia, chorea (sparks drawn from the spinal column), constipation (sparks drawn from the abdomen, and especially from over the sigmoid flexure), amenorrhœa (sparks drawn from the ovarian region), and generally in all low and depressed conditions of the system where a general stimulating and tonic effect is desired. A phantom tumour in a young woman, coupled with the most obstinate constipation, yielded in my hands to a vigorous use of the sparks after three séances ; she had been quite refractory to ordinary medicinal and moral treatment.

### Electrical Friction.

A metallic conductor connected with earth, or simply the hand, is pressed against the patient's clothes, and passed over the body. Discharge occurs by small sparks, which vary in their length according to the thickness of the clothes; a somewhat disagreeable multiple tingling is produced, and the skin is reddened. In addition to the local stimulation of the skin, a general sedative effect results; if, however, the application be prolonged, and practised upon great lengths of the body, general stimulation follows.

### Indications.

Neurasthenia, anæsthesia, cutaneous dystrophies, etc., spinal congestion with exaggerated reflexes, spermatorrhœa (Vigouroux, 'La Neurasthénie,' p. 251). This author adds:

'This is the only efficacious treatment I know of for spastic paralysis, a fact of so much the more importance because all other electrical applications aggravate the symptoms.'

The author has, however, obtained good results from strong galvanic currents in this condition (p. 285).

In the application of static electricity to ordinary cases of neurasthenia, it is usually best to begin by electric baths of short duration (five minutes), and after these have been two or three times repeated and lengthened, to go on to the *souffle* and sparks.

Dr. McClure ('Static Electricity in Medicine') lays down the fundamental law that, whether we use the *souffle*, the friction, or sparks, we ought to begin at the centres, and follow the course of the nerves from their origin to their termination. Even if it is a local affection that we are treating, the whole body should be generally treated, beginning at the head.

## CHAPTER II

### GALVANIC ELECTRICITY

APART from its valuable electrolytic effects, the most important therapeutical properties of the galvanic current are to be found in its power of relieving pain and spasm, and of stimulating muscles and nerves. We have seen that it is the best stimulus for involuntary and for degenerated voluntary muscles, and the only stimulus for the nerves of special sense.

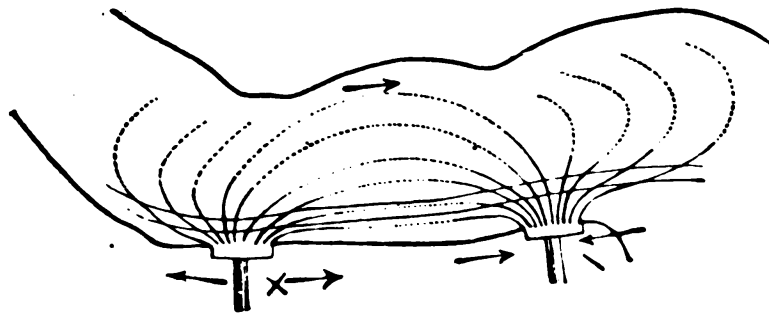

FIG. 129.—DIAGRAMMATIC REPRESENTATION OF THE AREA OF CURRENT DIFFUSION IN THE ORDINARY APPLICATION OF BOTH ELECTRODES TO THE ULNAR NERVE (Erb).

There are four different directions of the current in the nerve.

For whatever purpose we employ it, the effect it will produce will depend largely upon the density or concentration. At the points of entrance and exit of the current, this varies inversely with the size of the electrodes, and we can accordingly increase or diminish it there as we choose, so far as the feelings of the patient will permit; but when once it has penetrated the surface of the body, it is no longer under strict control.

Following the law of shunts and derived circuits, the current in traversing the body will pass almost entirely by those tissues that conduct it most easily, viz., the muscles; and it will spread out and diffuse itself in them, and in the surrounding tissues, in a way that cannot be calculated. It is therefore impossible, except by galvano-

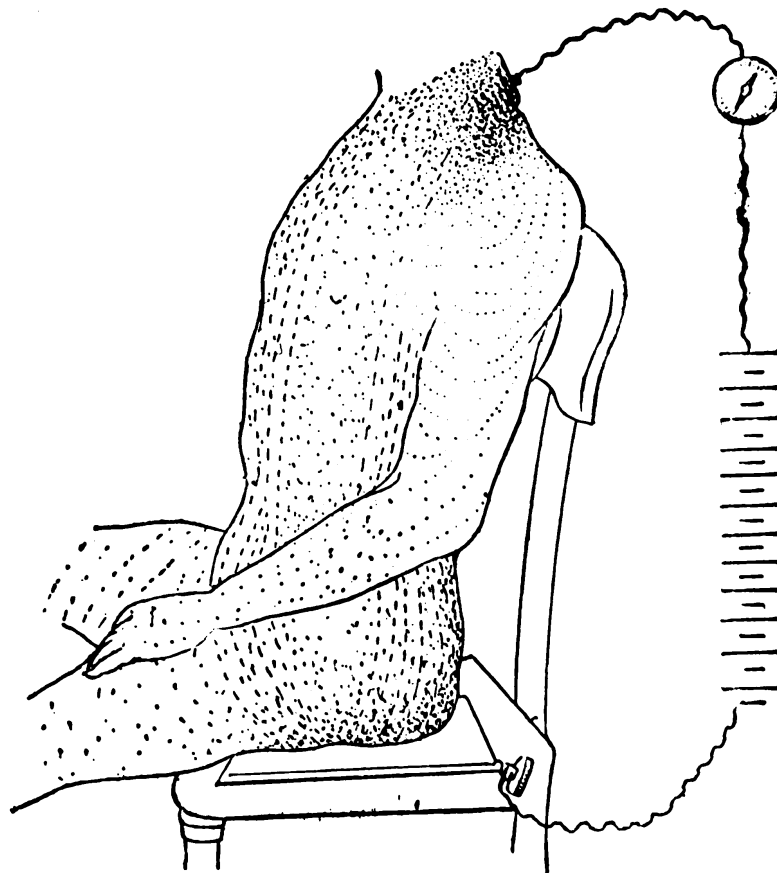

FIG. 130.—DIAGRAMMATIC REPRESENTATION OF THE DENSITY AND OF THE DIFFUSION OF A CURRENT IN TRAVERSING THE TRUNK.

The density is greatest beneath the small electrode.

puncture, to insure that a certain strength of current should traverse a desired organ, unless the latter should be quite superficial. Fig. 129 is a diagrammatic representation (from Erb) of the ordinary current diffusion in the application of both electrodes to the upper arm; Fig. 130 of the diffusion that may be supposed to occur



when one electrode is applied to the nape of the neck, and the other forms the patient's seat. It will be noticed that the current is much densest beneath the electrodes, and that though it passes mainly in the direct line between them, yet that there are diffusion currents passing down the arms and thighs. If it be a mere question of passing a current of a given strength through the body, then the larger the electrodes, the more easily the current will pass, fewer cells will be required, and the less the patient will feel it. If, on the other hand, it be desired to affect a particular superficial structure, such as the ulnar nerve at the elbow, then we shall gain very little, if anything, by employing a larger active electrode than is needed to properly cover it, although, if the number of cells be kept the same, the galvanometer will give a larger reading. No more current is now traversing the nerve than was the case when we employed a small electrode; in the one instance, a fractional part of a large current passed through the nerve; in the other, the larger part of a small current; while increasing the current-strength we have diminished the concentration; thus the galvanometer must not be solely relied on.

We may, however, lay down the following propositions:

To affect organs that are deeply situated (stomach, spinal cord, etc.), large electrodes and large current-strengths are required; and the electrodes should be placed in such positions as to have the organ directly between them, for, *cæteris paribus*, the current will pass by the most direct route.

To affect a small superficial structure, such as the ulnar nerve, the active electrode should be small, and well pressed down on to the nerve; the indifferent (inactive) electrode may be large.

As the negative pole always occasions more pain than the positive, it is usual to attach it to the largest electrode, unless a negative polar effect be especially indicated.

### **Modes of Application.**

Both electrodes and the skin should be well moistened with warm water. The electrodes may be applied in a 'unipolar' or in a 'bipolar' manner.

In the 'unipolar' manner, a large electrode is placed upon an indifferent spot such as the sternum; the active electrode is smaller, and is placed over the affected area.

In the 'bipolar' manner, both electrodes are placed in close proximity to one another over the affected area. Further, the electrodes may be applied in a 'stable' or 'labile' manner, and the current may be continuous, or interrupted, or reversed.

### **The Stable Method.**

The electrodes are kept in one immovable position, and the current, as a rule, is gradually increased or diminished by means of a rheostat or cell collector.

No shocks or muscular contractions result, and the effect in the region of the anode is a soothing one.

If the current be interrupted or reversed, stimulation will be produced. The term 'voltaic alternatives' (V. A.) is sometimes applied to the reversals; they act as very powerful stimuli, and should be used with caution, and not at all in the region of the head.

### **The Labile Method.**

The active electrode (usually the negative is selected) is rapidly passed up and down the nerve trunk or muscles, while a sufficient current-strength is maintained to produce vigorous muscular contractions.

### **Subaural Galvanization.**

This is sometimes termed galvanization of the sympathetic. One electrode is pressed deeply in below the ear, and behind the ascending ramus of the lower jaw, while the other is placed over the lower cervical vertebræ; a current-strength of about 5 to 10 m.a. is employed.

The physiological effects are disputed ; clinically, the method appears to be of service in exophthalmic goitre, vaso-motor neurosis, and affections of the vagus.

Beard and Rockwell have introduced the term ' central galvanization ' to indicate the following procedure :—

One pole, usually the negative, is placed at the epigastrium, while the other is passed over the forehead and top of the head, by the inner borders of the sternomastoid muscle, from the mastoid fossa to the sternum, at the nape of the neck, and down the entire length of the spine. By this method the whole central nervous system, as well as the vagus and depressor nerves, are brought under the influence of the galvanic currents at one sitting. They recommend it especially for simple exhaustion of the nerve-centres, and claim for it a powerful tonic effect. The author has practised it in cases of cerebro-spinal sclerosis, spastic paralysis, and paralysis agitans, with good results as regards the general condition in the first two, but with no obvious effect in the last.

#### **General Indications for Galvanism.**

Pain of all kinds, hyper-excitability, tinnitus aurium, spasms, and the symptoms of lateral sclerosis, can frequently be relieved by stable continuous currents with the anode over the painful or hyper-excitabile area.

For the treatment of paresis, paralysis, and to stimulate the involuntary muscles, interrupted stable currents with the negative pole over the affected area, or labile currents, or voltaic alternatives, should be employed.

#### **Direction of the Current.**

When the anode is over the central, and the kathode over the peripheral, parts of the body, the current is termed a descending one ; but if their positions are reversed, the current is an ascending one. The direction of the current is probably only of importance in so far as it indicates the position of the poles.

### Strength of Current.

Weak currents of from 1 to 5 m.a. should be used to begin with ; they may afterwards be increased according to circumstances up to 40 or 50 m.a. ; but a current of greater strength than 20 m.a. is rarely required for medical purposes. Especial care must be taken in galvanizing the head to avoid interruptions and reversals, and a current-strength of more than 5 to 10 m.a. is not easily borne.

### Duration and Repetition of Séances.

These are matters about which not very much is at present known. A séance commonly lasts for from five to fifteen minutes, and is repeated every two to four days, but it is quite impossible to lay down any rule. Much more care is requisite in dealing with cases of pain and spasm than with those of paralysis. Müller employs weak currents, short sittings (half a minute to three minutes), and a long duration of the treatment.

In cases of neuralgia and palpitation it may be of service to repeat an application several times a day ; in more chronic spinal cases, two or three times a week. After a certain number of séances, it is usually best to intermit the applications for a time, and after a month or two to renew them ; an increased effect may often thus be produced.

### Self-application.

A question often asked by patients is, ' Cannot I myself carry out the electrical application ? ' To this question Erb makes the following reply : ' Who is there that will bestow the time and patience which so tedious and seemingly monotonous a process requires ? To my mind there can be but one answer. The physician himself, and if possible one who devotes himself to electricity as a special pursuit. One may have a general knowledge of medicine and be an excellent practitioner ; but this is not enough, neither is it sufficient to possess a battery in order to become at once a skilful electrical physician. The practice

of electrization is far from being as simple as it seems. It needs study and exercise, just as any other manual art does ; and, in addition, it requires time and attention and a natural bent of mind, etc. We are often asked whether electrization cannot be performed by the patients themselves, their relatives, servants, or attendants. The answer is emphatically, "No." Still, it will occasionally happen that under pressure of circumstances, and out of regard to the patient's sufferings, this rule will be dispensed with. For my own part, I have often been tempted to relinquish the treatment into the hands of the patient or his friends, but I have always had to reflect that little if anything was to be gained by doing so.' All those who have practised electro-therapeutics will endorse Professor Erb's remarks. It may appear to be better for the patient's pocket to permit him to 'electrify' himself, but it is certainly worse for the prospects of an improvement in his bodily condition.

### FARADIC ELECTRICITY.

The chief uses of the faradic current are to stimulate and produce trophic changes. The stimulation is a primary effect, and is due to the rapidly repeated shocks that are administered ; the trophic effects are probably both primary and secondary, the former due to the action of the current *per se*, and the latter resulting from the muscular contractions.

#### Methods of Application.

They may be divided as follows :—

1. Local faradization.
2. General faradization.
3. The faradic or sinusoidal bath.

In the first of these the current is usually applied in the bipolar manner, two electrodes of medium or small size being held in one of the operator's hands. If the

muscles and deeper tissues are to be influenced, the skin and the electrodes should be well moistened, and the latter should be firmly applied ; if it be desired to affect the terminations of the sensory nerves, the skin should be carefully dried and dusted with violet powder, and while one of the electrodes (moistened) is held by the patient, or maintained in some fixed position, the other, a metallic brush, should be moved up and down the proper area. In cases where special organs have to be treated, the unipolar method may also be adopted ; thus the vagina, uterus, bladder, and larynx may be faradized by the introduction of one pole, while the other is applied externally over a neighbouring area ; or by means of a special bipolar electrode both poles may be introduced.

#### **General Faradization.**

This method, which has been especially studied by Beard and Rockwell, has for its object the subjection of every part of the body, so far as it is possible, to the influence of the faradic current. It is to be accomplished by placing the negative electrode at the feet, or under the buttocks, and moving the other one in sweeps over the general surface of the body. The feet may be placed in a vessel of warm water, in which the negative pole is immersed, or they may be placed in contact with a large foot-plate electrode. The movable electrode well moistened is carried from the forehead, over the vertex, occiput, and right down the spine, particular attention being paid to the cilio-spinal region. For this purpose a large soft sponge, folded over a brass ball, seems to be best (or the moistened hand of the operator, who thus transmits the current through his own body, may be used). Applications to the upper extremities and to the anterior surface of the trunk should also be included. The current-strength should always be first estimated by application to the operator's own person ; it should be weakest for the head applications, and may be considerably increased when the spine is reached. The duration of the séance

depends upon the condition of the patient, and the number and results of previous applications. Beard and Rockwell recommend an average application of fifteen minutes, one minute of which is to be apportioned to the head, seven minutes to the neck and spine, and the remainder to the abdomen and extremities. The spine and abdomen should receive the largest share of attention.

The applications should be repeated about three times a week, and continued for one or two months.

The treatment has a generally stimulating, trophic, and tonic effect, and is valuable in cases of exhaustion, debility, and chronic nervous diseases.

### **The Faradic or Sinusoidal Bath.**

This is undoubtedly a valuable addition to electro-therapeutical appliances, and in the form of small local baths for the extremities is coming into extended use.

### **Requisites.**

A bath of porcelain, earthenware, enamelled zinc, or wood (a portable rubber or canvas one will do).

Leslie Miller supplies the arm and foot baths. The sinusoidal current from an alternating main suitably transformed down, or a small motor dynamo sinusoidal machine (p. 122) for the direct current from the main, or, failing these, a large induction coil with a secondary of relatively thick wire ; for the latter, five accumulators or ten large Leclanchés will do. The second and third sources of supply are the safest, and should be adopted, for with the first it is difficult to avoid a possible short circuit between the bath containing water and the earth. If the first method be adopted, it is best not to attempt to insulate the bath, but to connect it together by means of its cold water and waste pipes firmly to earth. Further, a resistance lamp should be inserted both on the wire coming to and on the wire leaving the patient (*vide* Dr. Hedley's hydro-electric methods).

For a galvanic bath twenty to thirty large-sized cells and a galvanometer reading to 200 m.a. are required.

Electrodes of carbon, lead, or copper, of large size—4 by 8 inches to 10 by 15.

Two methods are chiefly employed—the unipolar and the bi- or dipolar. In the *unipolar*, one electrode is placed in the water, or connected with the bath, if it be of conducting material (plain copper); while the other consists of a rod, passing across the top of the bath, which the patient grasps. The water should be at a temperature of about 98° F., and if the battery and coil be not sufficiently strong, a little salt or vinegar may be added. The whole of the current passes through the patient, entering by that part of his body which is in the water, and passing out by his arms.

In the *bipolar* method both electrodes are placed in the water, one at the head, and one at the foot, the patient's body being prevented from touching them by a light wicker frame. Plain water should be used. Only a small fraction of the total current now passes through the body, by far the larger portion through the water. Dr. Hedley (*British Medical Journal*, February 20, 1892), by a series of careful experiments on the physics of the electric bath, has shown that the immersion of the body in the water in the direct line of the current causes a lateral divergence of the lines of force, and that the greater part of the current passes round, and not through, the patient. The waste of current in a dipolar bath is in excess of what is generally believed, and the calculation sometimes made, that the patient receives one-fifth of the total current, is too high. Hedley states ('Therapeutic Electricity,' 1899) that the *average* current passing through the body is about 25 per cent. of the total current.

The sinusoidal bath is probably much more useful than the galvanic; unless the latter be interrupted, it is difficult, in view of M. d'Arsonval's experiments, to see what it can do, except to be capable of removing by electrolysis or by cataphoresis noxious substances (metallic poisons,



etc.) from the body. Medicinal substances can certainly be introduced by the unipolar galvanic bath (pp. 294, 304).

The duration of a bath should vary according to the condition of the patient. A usual period is from ten to twenty minutes.

The strength of the current should be such as to cause agreeable muscular contractions. If the continuous current be used, it may attain 150 m.a. or more, but should be very gradually brought up to this.

#### Indications for the Faradic Bath.

Broadly speaking, they are the same as those for general faradization and the static bath. Thus a course of baths (a dozen) may be of service in neurasthenia, nervous debility, overwork, and hypochondriasis ; also in chronic gout and rheumatism, sciatica, lumbago, obesity, certain diseases attended with tremors, paralysis agitans, and skin affections. A case of Dr. Smart's of pseudohypertrophic paralysis derived much benefit from a course of sinusoidal baths in the Edinburgh Royal Infirmary.

MM. Larat and Gautier have made an extensive use of the electric bath, fed by alternating electric light currents properly transformed down ; such currents are almost sinusoidal in their nature, and they appeared to the author, who made trial of them when in Paris, to be exceedingly agreeable. These gentlemen have found that the physiological effects observed by M. d'Arsonval were confirmed by the therapeutic results. The excretion of urea in patients rapidly returned to the normal ; one could also, at the same time, almost see their general condition improving. They had extremely satisfactory results in chronic gout and rheumatism, in persistent sciatica, and in conditions of obesity. In eczema the improvement was surprising. A case of three years' standing was cured in ten days and by six baths, nor has there during the last three months been any return. They are of opinion that the diathesis of a patient can be modified, at least for a time, by this method of electrization.

The galvanic bath has been recommended in rheumatoid arthritis, chronic gout, metallic poisonings, and for cataphoric purposes (pp. 179, 294, 304).

Local electric baths are of much service. The arm baths, consisting of convenient-sized stoneware troughs with a copper electrode at either end, save time and trouble in that the patient, his arm once immersed and the current adjusted, requires little further attention ; they are useful in cases of paralysis of the forearm muscles and in local rheumatic and gouty conditions. The sinusoidal current (p. 121) is used for these baths in the Electrical Department of the Edinburgh Royal Infirmary. Dr. Thomas Barlow recommends them in Raynaud's disease, and Dr. Lewis Jones has also found them of service in melancholia, rickets, and chilblains. In the author's opinion the sinusoidal current is the most effectual electrical treatment for rheumatoid arthritis.

#### **The Electric Douche.**

Dr. Hedley, our best authority on hydro-electric methods, describes his apparatus as follows ('Therapeutic Electricity,' W. S. Hedley) : 'The apparatus consists of a short length of flexible rubber tubing, having an inside conducting wire, one end of which is brought out and connected to a terminal about 2 inches from the brass union which joins on to the supply pipes. The 2 inches of rubber tubing thus interposed between the metal pipes and the conducting wire act as effective insulation at this end of the arrangement. The other end of the internal wire is soldered to the inside of the metal screw, to which different nozzles may be attached. Continuous currents require a pressure of 50 to 60 volts, alternating currents from a fair-sized bath coil pass through more easily. If salt water be used, stronger currents will be obtained. Dr. Hedley's recent experiences leave no doubt in his mind as to the usefulness of this douche in old-standing paralysis, neurasthenia, and anæsthesia.' The other terminal should be placed in the bath in which the patient

18—2

stands. Dr. Guyenot, of Aix les Bains, employs two douches, one to bring the current up to the patient, and the other to take it away. This seems to be an original and useful method of application.

#### **Galvano-Faradization.**

Under this name, Dr. de Watteville introduced a method of sending both currents together through the body.

The positive pole of the battery can be united in one circuit to the negative pole of the induction coil, and the electrodes attached to the positive terminal of the coil, and to the negative terminal of the battery. Dr. de Watteville's key enables this to be done very readily. The value of this method has not yet been sufficiently established, but it is stated that the stimulating action of the one current, together with the anodyne and 'refreshing' action of the other, is obtained; that muscular contraction is excited, while pain is soothed and exhaustion prevented. De Watteville recommended the method for electrization of the abdominal organs, and for rheumatic conditions and atrophic paralysis, etc.

The two currents may be conveniently administered by means of the bath.

## CHAPTER III

### DISEASES

THE chief conditions for which electricity is usefully employed in medical therapeutics are affections of the nervous system. It may in certain functional disorders be used to promote a cure, but more commonly to relieve symptoms. The chief of these are, in the case of the motor nerves, spasm and paralysis ; in the case of the sensory nerves, pain and anæsthesia. The following principles, speaking generally, should guide us in dealing with these conditions :\*

#### **Spasms and Contractures.**

Employ unipolar stabile galvanic currents with the anode over the affected part, and if unsuccessful try the bipolar plan.

A second excellent method is to make local applications of the static breeze or friction.

A third is to counter-irritate and produce a reflex effect by the faradic brush.

#### **Paralysis.**

The treatment must consist of applications both in *loco morbi* and in *loco symptomatis*.

Weak stabile galvanic currents may be applied to the seat of the lesion ; faradic currents, or kathodic interrupted galvanic currents, to the muscles.

#### **Pain.**

Unipolar stabile strong galvanic currents with the anode applied over the affected nerve, and particularly

\* For treatment by ' high-frequency currents,' see p. 413.

over any painful or tender points, should be used. The current may reach, with electrodes of large size (30 square inches), 80 m.a., and it should be very gradually decreased. Frequent repetitions are often useful.

The static breeze is to be strongly recommended, and is the form of treatment most generally used by the author. The faradic current induces a sort of local anæsthesia, and by the production of muscular contractions breaks down or loosens painful adhesions. Apostoli and others have employed it successfully to relieve neuralgia. It may also be used to alleviate the condition indirectly by setting up counter-irritation with the brush.

### **Anæsthesia.**

The static bath followed by sparks drawn from the affected patches, or vigorous faradic brushing, is the most suitable treatment. The electric douche is recommended by Dr. Hedley.

## **GENERAL NEUROSES.**

### **Neurasthenia.**

General measures are necessary ; commence by daily five-minute séances of the static bath, and then gradually prolong their duration ; after a time proceed to the *souffle* applied to the occiput, and to sparks drawn from the general surface of the body. Inform the patient that, although his condition will quickly improve, yet that relapses are common, and that the treatment should be persevered in for a month at least. Vigouroux remarks ('La Neurasthénie,' p. 275) that in cases of Graves' disease the treatment is contra-indicated, and that it should also be suspended during the menstrual period, if the patient is subject to menorrhagia. All the cases of neurasthenia that have come under his notice, except those complicated with arterio-sclerosis, no matter how grave their apparent condition, were cured by this method, although the majority of his patients had previously unavailingly tried all other known remedies.

My own experience, based upon the results obtained in the electrical department of the Royal Infirmary and at home, confirm this. I have not seen a case of nervous exhaustion or debility, such as that which follows influenza or typhoid, which has not derived material and rapid benefit from static electricity.

The appetite is increased, weight is gained, the amount of urea is augmented ; and not only does the amount of the normal constituents of the urine increase, but the abnormal substances tend to disappear (albumen, indican, sugar, etc.).

If static applications cannot be obtained, the sinusoidal bath and general faradization should be employed.

### Hysteria.

Static electricity gives the best results, but great care must be exercised in its administration ; a few turns of the machine will sometimes produce a paroxysm. After the patients have become accustomed to the simple bath, recourse may be had to more energetic measures. Pains and hyperæsthetic patches may be treated by the *souffle* ; anæsthesia by the spark. The records of the hysterical cases treated by static electricity in the Royal Infirmary are very favourable ; in only one case were the symptoms unrelieved. Professor Charcot (*Leçons sur les Maladies du Système Nerveux*, p. 359) says that experience has shown that, after the static bath, the sensibility of patients suffering from hysterical anæsthesia usually returns, at first for a short time, but afterwards, if the baths be continued, for longer and longer periods, until completely restored. At the same time the other hysterical phenomena are commonly ameliorated, and may disappear. Local faradization is often of service. In aphonia both poles may be placed, one on either side of the larynx, or in more obstinate cases one pole may be introduced by a suitable laryngeal electrode. One percutaneous application is often sufficient. Anæsthesia may be sometimes removed by a few applications of the faradic brush.

**Insomnia.**

This often yields to static electricity. The breeze should be applied to the region of the head; either a single point, or several attached to a cap, which is suspended over the patient's head, may be used.

**Melancholia, Hypochondria.**

A stimulating plan of treatment should be persevered with—static electricity, with sparks, the faradic bath, general faradization, and the metallic brush.

**Chorea.**

This disease, after running a more or less definite course of about six weeks, usually disappears spontaneously. There is, therefore, often difficulty in deciding how much effect electrical treatment may have exercised.

Static and galvanic electrization seem to be of most service.

Onimus recommends a continuous ascending current, the anode being placed at the extremity of the limb, and the kathode on an indifferent spot. Some remarkable cures were thus obtained by him. Drs. Addison, Golding Bird, Sir W. Gull, Vigouroux, and others, have had very successful results with static sparks drawn from the whole length of the spine. Dr. Golding Bird mentioned that out of thirty-seven cases so treated thirty were cured. Many other excellent records have appeared in the Guy's Hospital Reports. The late Sir W. Gull was a strong supporter of this method, and recommended its employment even in the most severe cases. Caution is required in commencing this treatment with choreic patients.

**Paralysis Agitans.**

Little that is encouraging can be found in the electrotherapeutical records of this disease. The author made a prolonged trial of central and local galvanization in one well-marked case without obvious result. Electrical

baths have been recommended. More recently he has observed benefit follow the static breeze, while high-frequency currents were unavailing.

### Exophthalmic Goitre.

On the supposition that the cervical sympathetic is involved, subaural galvanization has been frequently tried in this disease. Dr. Cardew (*Lancet*, July, 1891) recommends frequent repetitions of weak continuous currents—of from 1 to 3 milliampères in strength—to this region, with the anode over the lower cervical vertebræ. He believes that :

1. Galvanism is superior for this purpose to faradism.
2. A current-strength of 2 to 3 milliampères is sufficient.
3. Each application should last six minutes.
4. Frequent applications (three times a day) should be made.
5. The anode should be placed on the nape of the neck, the centre of its lower border corresponding to the seventh cervical spinous process, and be held firmly in that position during the application. The kathode should be moved and up down the side of the neck from the mastoid process along the course of the great nerves.

The patients, he thinks, should be provided with a suitable battery of a few cells, and be taught to make these applications to relieve their palpitation themselves. The author has observed that the pulse-rate could usually be reduced by this method by about ten beats, but it is very difficult to avoid fallacies in the case of such neurotic patients. The resistance of the tissues is so much diminished that two to five cells are usually ample. The author noticed that these cases were treated by Vigouroux at the Salpêtrière by faradic currents. One pole is placed successively over the goitre, the præcordia, and the margin of the orbit ; the other on the nape of the neck : each region is gently faradized for about two minutes. The anode is used for the præcordia and the goitre, and the



kathode for the orbicularis muscle ; the anode is also applied to the closed lid. Dr. Vigouroux, from the results of his large experience, is enabled to speak favourably of this method ; he told the author of one case which had been for a long time unavailingly treated by galvanism, which was at once relieved, and eventually cured, by faradism. The applications should be repeated every day, and kept up for several months if necessary. The tachycardia and the exophthalmos are the most readily ameliorated.

### **Tetany.**

In this disease the electrical and mechanical irritability are increased. Trousseau pointed out that compression of a main artery or of a nerve trunk could provoke an attack, and Erb showed that the electrical irritability was increased. The thyroid gland is sometimes enlarged. It has been stated that the increase of irritability is most marked in the facial nerve ; it persists in the intervals of apparent good health, and may thus be of some service in diagnosis. Kathodal closing and anodal opening tetanus are easily obtained. The nerves respond to very weak faradic currents.

Unipolar stabile applications, with the anode over the affected parts and over the cervical spine, and the kathode over the sternum, have yielded favourable results.

### **Writer's and Telegrapher's Cramp.**

Erb recommends general and systematic galvanization of the whole motor apparatus. The head is to be galvanized transversely, longitudinally, and obliquely ; then the cervical sympathetic and cervical cord ; and, finally, he advises peripheral galvanization of the nerves and muscles, either labile, in the tremor-like and paralytic forms, or principally with stabile currents, in the spastic form. Comparatively weak currents are to be chosen, and all overstimulation of the motor apparatus avoided. Vigouroux does not consider these affections to be simple

disturbances of the co-ordination centres brought on by overuse. He has observed writer's cramp in people who write but little, and their incapacity is not limited to this function only, but is shown in various degrees, and according to the precision of the exercises required, in other movements of the limb; their general health is also affected. They exhibit a peculiar diathesis, and their functional incapacity arises simply from changes in the peripheral nerves, or in the muscles and tendons, or in their blood supply. Treatment directed to these conditions will therefore yield the best results. He recommends energetic massage of the muscles, the execution of special gymnastic exercises, and general static electrization. Dr. Poore places the anode in the axilla, and the kathode over the ulnar nerve, and uses a continuous current, during the passage of which the patient is encouraged to exercise the interossei and other muscles by rhythmical movements.

## AFFECTIONS OF THE BRAIN AND SPINAL CORD.

### Cerebral Hæmorrhage.

After a hemiplegia has become chronic, applications may be made to the damaged part of the brain, to the spinal cord, and to the paralyzed muscles.

For the first of these conditions: Weak (1-5 m.a.) stabile continuous currents with large electrodes should be applied so as to include the damaged area between them, for a few minutes every other day. A powerful rheostat, to permit of more exact graduation of the current, is of service.

For the motor tracts: The anode may be placed on the vertex, or over the seat of the lesion, while the kathode is slowly moved up and down the spinal cord. (The object of this is to assist in clearing a path for the voluntary motor impulses, and to prevent descending degeneration.)

For the muscles : The anode may be placed over the cervical region for the arm, and over the lumbar region for the leg, while the kathode is moved about in a labile fashion over the peripheral nerve-trunks and motor points ; bipolar faradic applications may also be used.

Any constipation should also be attacked by vigorous galvano-faradization of the abdomen.

### Infantile Paralysis.

As the lesion involves the second trophic realm (the multipolar nerve-cells in the anterior cornua being destroyed), some of the muscles, those supplied by these cells, will undergo degeneration and atrophy ; these then will, according to the time that has elapsed from the attack, either exhibit the reaction of degeneration or fail to respond at all. Other muscles, whose trophic centres were only injured and not destroyed, may react to galvanism normally, but not to faradism, while the remaining muscles react normally to both currents.

Treatment may be begun as soon as the condition has become chronic. Galvanism, faradism, or galvano-faradism may be used. Employ bipolar applications to the seat of the lesion to endeavour to restore the nutrition and vitality of the damaged cells, and bipolar or unipolar applications to the affected muscles, with the current which serves best to stimulate them. Static sparks will sometimes succeed in causing an effort at a contraction when other means fail. Massage, passive movements, and systematic exercising should also be practised. The late Dr. Steavenson treated many cases successfully by the faradic bath, and this is now the standard treatment.

### Progressive Muscular Atrophy.

The electrical reactions in this disease are at first unaltered ; afterwards there is a diminution in the irritability, and still later partial, followed by complete, R.D. But little can unfortunately be expected from electrical

or other treatment. Erb says that the electrical current is no real cure for this disease. The numerous, and sometimes even brilliant, curative results said to have been attained are generally the consequence of errors in diagnosis; he has never seen recovery in the true typical form of the disease, though he has seen improvement, relief, and retardation of progress. Galvanization of the spinal cord, followed by galvanization and faradization of the affected neuro-muscular areas and the faradic bath, may be tried.

### Lateral Sclerosis.

Considerable improvement can usually be obtained in this disease. The author, using unipolar stabile galvanization, has had good results in several cases. Two large pad electrodes (the negative one may be 8 inches square) are chosen, and the one placed over the lumbar region of the cord, and the other over the abdomen. The positive pole should be attached to the electrode lying over the cord. Weak stabile currents, if great care be taken to avoid any interruptions, may be tried at the commencement of the treatment, and their effects observed; they may afterwards, if necessary, be increased to 40 or 50 m.a. A séance may last about twenty to thirty minutes, and be repeated once or twice a week. The following case is instructive: A patient, A. B., aged thirty-four, consulted the author in May, 1891; he had been ill for rather more than a year, and presented all the signs and symptoms of spastic paralysis. The patient ascribed his condition to a fall he had had some three months before his illness began. He was now unable to walk alone, and was for the greater part of the day confined to bed. He complained also of an aching, tired feeling in the lumbar region and of urinary incontinence. After half a dozen séances, these symptoms had quite disappeared, and under a continuance of the treatment he improved so much that he could walk quite well by himself. The current-strength had averaged about 15 m.a. After attaining this stage

of improvement, the applications were discontinued, and the patient advised to return in two months' time ; this he did not do, but, returning to his work, which necessitated much standing, he went on until his condition again became aggravated. On his return in about five months, a repetition of the former applications entirely failed to afford him any relief whatever ; recourse was now had to much stronger currents, 40 to 50 m.a., and with satisfactory results. The patient steadily improved, and was soon brought back to his former level. The late Dr. Steavenson informed the author that he had nearly always obtained an improvement in the symptoms by this method of treatment.

Dr. Vigouroux strongly recommends static friction to the limbs, and I have at present a lady under my care who has derived considerable benefit from static friction to the spinal column.

#### **Locomotor Ataxy.**

The lightning pains can sometimes be relieved by stable continuous currents, the anode being applied over the region of the roots of the painful nerves, or over any tender or painful spots. Faradic currents sometimes give relief. Rumpf recommends farado-cutaneous brushing ; the skin of the extremities and of the back is to be strongly stimulated for about ten minutes at a time by the faradic brush. Rumpf reported that of twenty-four cases so treated four were completely cured, ten considerably improved, and only one experienced no permanent benefit (antisyphilitic treatment was administered at the same time).

For the ocular and other symptoms, subaural galvanization, or careful faradization, extended also to the whole length of the cord, can be tried. Some of the French authors consider the faradic current in any form to be absolutely contra-indicated. In numerous cases treated by the static breeze in the Edinburgh Royal Infirmary some amelioration has resulted. The X rays to the lumbar spine have also been found by me of service.

## CHAPTER IV

### PERIPHERAL AFFECTIONS

#### Facial Paralysis.

THE chief varieties of this affection and their electro-diagnosis have already been pointed out. The condition can be treated by labile applications of the galvanic current ; the anode is placed behind the ear, or on an indifferent spot, and the kathode is moved slowly about from the centre towards the periphery over the branches of the nerve and motor points ; the current-strength should be about 3 m.a. Even if the muscles react to faradism, it is often safer to avoid it, lest secondary contractures result. Vigouroux for this reason avoids the local electrical treatment altogether, and contents himself with placing the patient on the insulating stool, and administering a static bath. Dr. Reynolds has recommended the faradic brush ; this may do good reflexly by stimulation of the fifth nerve.

#### Pressure Paralysis—Lead and Alcoholic Paralysis.

The principles of treatment are to get, if possible, beyond the seat of the lesion, and to include the whole length of the nerve in the circuit.

The anode may be placed in the axilla or supra-clavicular fossa for crutch paralysis, and over the cervical region for lead paralysis, and the kathode used in the labile method over the affected muscles. The constipation in lead paralysis should also be treated. The static

breeze is useful for the head symptoms. In cases of traumatic paralysis from division of nerves, the same plan can be adopted. Bipolar faradic currents are often sufficient. In all forms of motor paralysis, it should be remembered that the static sparks may elicit contractions when galvanism and faradism fail.

## NEURALGIA.

### Tic Douloureux.

The severity and persistence of this affection are probably due to the fact that the pain is not so much a neuralgia as the symptom of a neuritis, and is occasioned by the swelling of the nerve in some one of the bony canals through which it passes. These canals are also so deeply situated that it is difficult to influence the point of lesion efficiently with currents of ordinary strength. Static electricity, with the breeze directed to the painful area, can first be tried (see also high-frequency currents); this can be alternated with unipolar anodal continuous currents. Short séances, of from three to four minutes' duration, and frequent repetitions, are desirable. Bordier's method is a new and successful one.

Bordier recommends the constant current with the anode over the affected part; the indifferent electrode must be very large (40 square inches), and the active electrode 12 square inches; they should be made of aluminium or platinized copper thickly covered with felt and maintained parallel to the surface of the skin. For tic douloureux the active electrode may be divided into three parts, the one applied to the forehead, the second between the eye and upper lip, and the third to the chin below the lower lip. The current should then be brought up to from 30 to 80 m.a., and should be continued for an *hour* daily. This large current produces important nutritional changes along its lines of flow, and a rapid relief and eventual cure of the neuralgia (*Journal des Praticiens*, November 30, 1901). The author has sometimes

observed relief follow a course of exposures to the X rays, and he would recommend their trial when Bordier's method fails.

### Sciatica.

The pain here is also usually due to a neuritis, a perineuritis, or it may be to pressure exerted upon the nerve in the pelvis or vertebral column. Such causes should be most carefully sought for before electrical treatment is begun. The best results are obtained in recent cases that are of a rheumatic or purely neuralgic origin.

Various methods of treatment may be tried.

The anode may be placed over the lumbar region, and the kathode carried along the course of the nerve (current-strength from 6 to 30 m.a.); after a few minutes' séance, painful and tender spots should be diligently sought for, and the kathode applied to them for a minute or two in a strictly stable fashion, or the same procedure may be gone through with the poles reversed. The patient should always rest after these applications.

Dr. Bartholow remarks that there is no painful affection in which the application of electricity is more conspicuous for good than in sciatica. He is decidedly in favour of strong galvanic currents—20 to 40 m.a.—applied in the manner first mentioned, especially in long-standing cases, which he has seen yield in a surprising manner to the applications.

The late Dr. Steavenson reported favourable results in a number of cases treated in much the same manner, but with the anode over the abdomen. Of sixty-seven cases, thirty-seven were cured, one had a return of sciatica and was cured a second time, eleven improved only, etc.

The faradic current may be used in two ways to relieve the condition :

The first method consists of ordinary bipolar applications, with moist electrodes. These probably act by setting up vigorous muscular contractions, which tend to loosen any adhesions which may have formed round the



nerve-sheath or nerve-fibrils. Its success is in many cases indubitable. It should be of most service in the rheumatic sciaticas.

The second method of using the faradic current is to set up a severe counter-irritation by means of the brush on a dry skin. It has been employed with excellent results by Duchenne and others. The pain it occasions is its disadvantage.

For those who have a static machine at hand, the readiest and quickest plan is to try the breeze. The patient should stand up on the insulating stool, and the point, held at a distance of a few inches, should be slowly passed up and down the course of the nerve. This is the form of treatment that I have found of most service in sciatica, and I have used it with successful results in many cases (see also High-Frequency Currents, Part VI.).

If this sedative method does not answer, strong counter-irritation by the sparks may succeed.

Cervico-brachial, cervico-occipital, and other neuralgias, including the pain attending herpes zoster, should be treated on similar lines, and do not require special mention. The application should in all of them be frequently repeated.

### **Tinnitus Aurium.**

All those who have had experience of cases of this distressing affection would be glad to welcome any agent that might alleviate it. This the galvanic current is sometimes able to do (Brenner, Erb, Althaus, Steavenson, etc.).

The authorities are, however, agreed that there is no other electrical application which demands such care or skill in its proper performance as the galvanic treatment of tinnitus, and that the failures which have frequently attended the efforts of those aurists who are not at the same time electricians should not be placed so much to the account of the agent employed as to the defective method of employing it. Erb remarks, with regard to the technique of this plan of treatment, that it requires in most cases an unusually high degree of exactitude and

neatness in carrying it out, trustworthy apparatus, with skill and judgment in its use, an exact knowledge of the facts belonging to the subject, and a clear idea of what ought to be accomplished ; and all these conditions are very seldom combined.

The causes and varieties of tinnitus are manifold, nor has it yet been at all decided for which conditions the galvanic treatment is most suitable. The therapeutic experiment for each individual case alone can guide us.

A good galvanometer and rheostat are essential.

The acoustic reactions (see p. 165) must first be ascertained. There may be simple galvanic hyperæsthesia, or serial changes may be superadded, or the latter may be present alone, or the reactions may be quite normal. The patient should, during this procedure, fix his whole attention upon the noises, in order to observe whether they undergo any modification during the variations in the current, for the treatment to be adopted will depend mainly upon these results. Thus the acoustic reaction may be normal and the tinnitus quite unaltered ; then the electrical prognosis is not good. The tinnitus may, however, be increased by one pole and diminished by the other. The rule now is to select for the therapeutical application that pole by which the subjective noises are most diminished.

With the rheostat and galvanometer in the circuit, apply a well-moistened medium-sized electrode, attached to this pole, to the external meatus, or just in front of it ; let the other electrode be grasped firmly in the patient's hand ; or, the patient's head being inclined to one side, and resting upon a pillow, with the affected ear uppermost, the latter may be filled with warm water, and a suitable electrode introduced. Yet another plan is to apply a divided electrode to both ears in cases where there is much hyperæsthesia, and where the other ear, though not in contact with an electrode, also responds (paradoxical reaction).

With the rheostat at zero the current may now be gradually turned on by the cell collector and brought up

to a strength of about 5 m.a. ; it may be continued for about five to ten minutes, according to the effect produced on the noises, and should then be very gradually and slowly diminished by manipulation of the rheostat.

The effect produced will depend mainly upon the strength and duration of the current. Thus, a tinnitus which is but little affected by the establishment of the current may, and frequently does, diminish during its passage, disappearing in favourable cases altogether. It sometimes happens that the noises reappear as the current is cut off. If this should happen, the strength may be again increased, and then once more very slowly diminished by steadily augmenting the resistance of the rheostat.

Our object should always be to increase as much as possible the effect of the favourable pole, while avoiding the prejudicial action of the other one. The anode commonly has the most favourable effect, and we may therefore suppose that this is due to the establishment of anelectrotonus ; but when the current is cut off this condition of diminished excitability is replaced by one of greater excitability, so that every care should be taken to bring this change about as gradually as possible, and so to avoid the stimulation of a sudden variation.

The tinnitus, to take a favourable case, is, as a rule, only temporarily diminished or dispelled ; it returns again very shortly, but can be again removed by the electrical treatment, and for a longer period. Each successive séance has in this way a more prolonged effect, until a complete cure is obtained. Some cases are benefited by static electricity, especially those depending upon thickenings of the tympanic membrane. Sparks are drawn from the membrane by means of a rubber speculum containing a wire. Both the tinnitus and deafness may be improved.

#### Deafness.

Dr. Fergusson reports cases that were successfully treated by high-frequency currents (p. 415).

**CONSTITUTIONAL AFFECTIONS.****Acute and Chronic Rheumatism.**

Lewandowski strongly recommends the faradic brush; this is applied to the skin directly over the affected joint until decided redness is produced. He affirms that the pain and fever can be thus diminished, and the duration of the disease shortened.

For chronic articular rheumatism, the sinusoidal local or general bath is usually preferred. The cataphoric effects of the continuous current have been tried with success by Donald Baynes (p. 294). Though chronic rheumatism often proves very refractory to electrical treatment, the author has frequently observed good results follow a course of baths.

**Lumbago.**

Muscular rheumatism is *very* amenable to both static sparks and to the galvanic and faradic currents. A bipolar faradic application, with a current strong enough to cause vigorous muscular contractions, will usually relieve the pain and stiffness at once. The author has observed this in numerous cases. Rheumatic torticollis should be treated in a similar manner.

**Rheumatoid Arthritis.**

Stabile unipolar currents, with the anode over the spinal origin of the nerve supplying the joint, and the kathode over the joint itself, are sometimes efficacious; or bipolar applications, with the electrodes on each side of the joint, may be used. Cataphoresis might also be of service here. The author has also tried the high-frequency couch (p. 414), but without success; he would recommend a trial of the sinusoidal currents. Some amelioration can usually be obtained if the treatment be persevered with.

**Gout.**

A paper was read at the International Medical Congress in Berlin in 1890 on Mr. Edison's experiments on the removal of gouty concretions by electrical endosmosis

(cataphoresis). As an illustration, one hand of a healthy man was placed in a solution of chlorinated lithia, the other in one of chlorinated soda ; the latter was connected with the positive pole, and the former with the negative. A current of 4 m.a. was passed for two hours a day—eleven hours in all. Spectroscopic examination of the urine showed that considerable quantities of lithia had passed into the man's body. Experiments were now performed upon gouty patients, with apparently successful results ; the pain ceased, and the gouty concretions diminished in size. A local bath should be prepared containing a 2 per cent. solution of lithium chloride. This should be rendered slightly alkaline by the addition of caustic lithia of a strength of 0.5 per 1,000. To this solution the positive pole should be connected. The affected part being immersed in the bath, the negative pole should be attached to a very large indifferent electrode. A strong continuous current (50 to 150 m.a.) should be kept up for half an hour. The larger the negative electrode the less pain will be felt. Lithium urate will be found in the urine (see also Dr. Baynes's detailed paper in *Medical Electrology and Radiology*, April, 1904, for the whole subject of cataphoresis in gout and rheumatism).

#### Diabetes.

Vigouroux states that the glycosuria sometimes observed in neurasthenic patients quickly yields to static electricity. Charcot also reports a case of diabetic paraplegia ('Archives de Névrologie,' 1890) considerably improved by the same treatment. This patient was, on his admission, passing 16 litres of urine and 1,050 grammes of sugar per day. He was placed upon a diabetic diet, and subjected to ordinary medicinal treatment, without the glycosuria being influenced. This treatment was then suspended, and static electricity alone tried. In three months' time the paraplegia had almost disappeared, the general condition much improved, the sugar had fallen to 360 grammes per day, and the polyuria had diminished by more than one half.

## CHAPTER V

### AFFECTIONS OF THE ALIMENTARY SYSTEM

#### Dyspepsia.

GENERAL faradization, the sinusoidal bath, or static applications are perhaps of most utility here. Dr. Herschell ('Polyphase Currents in Electrotherapy') recommends the use of triphase sinusoidal currents with one pole on the epigastrium, one on the small of the back, and the third to the interior of the stomach in cases of 'gastric atony and atonic dilatation' of local origin.

#### Dilatation of the Stomach.

Energetic faradization or galvano-faradization with large electrodes, so placed as to include the organ between them, are recommended (see also High-Frequency Currents, p. 414). Dr. Baraduc ('Electrothérapie,' Larat, p. 317) has treated cases very successfully by the introduction into the stomach of one of the electrodes. The stomach being first washed out, a sufficient amount of slightly salted water (Vichy water) is introduced, and a suitable flexible electrode passed down the syphon tube, until its end projects about 1 inch beyond the tube (the length requisite for this must have been previously measured); the other electrode is placed on the back or epigastrium. Dr. Baraduc used the faradic current, of a strength sufficient to make the patient sensible of slight muscular contractions; each séance lasted four to five minutes. Improvement was at once manifest; the ob-

jective and subjective symptoms were alike ameliorated, and the digestive powers strengthened.

Dr. Boisseau du Rocher, in a communication to the French Academy of Medicine in 1890, and to the *Revue d'Electrothérapie*, November, 1891, recommends the internal applications of static electricity. The following are his conclusions :

1. Internal franklinization rapidly restores (in five to six séances) a dilated stomach to its normal dimensions.
2. The digestion is improved after the first séance.
3. Constipation usually disappears after the third or fourth séance.
4. The urinary secretion becomes normal.
5. The ptomaines rapidly leave the urine, and totally disappear after the third séance.
6. Except in extraordinary circumstances, the internal static applications are excellently tolerated.

#### **Gastralgia—Vomiting.**

Gastralgia should be treated on the same principles as other neuralgias. Nervous and functional vomiting was relieved by Duchenne by faradization of the epigastric region ; others have been successful with subaural galvanization. Larat records a case of vomiting that had lasted almost a year, and that had resisted all other treatment, but which yielded at once to galvanism. He placed the anode over the cervical spine, and the kathode over the epigastric region, and passed a current of from 12-15 m.a. for a quarter of an hour. On his discontinuing the treatment, the vomiting returned again, but again yielded to the current. The séances should be held every day ('Electrothérapie,' Larat, p. 315).

#### **Constipation and Obstruction.**

For this troublesome, common, and sometimes dangerous affection, nearly all the methods of electrical treatment have been tried. Aperient drugs should be entirely given up during the electrical treatment.

For ordinary cases, bipolar faradic or sinusoidal applications, with the electrodes well moistened and pressed deeply down into the iliac fossæ, are usually sufficient. Vigouroux recommends strong static sparks drawn from the whole abdominal area, but particularly from over the sigmoid flexure. This is a simple and ready plan of treatment, which has been successful in the author's hands, and which, if static electricity can be obtained, is certainly worth a trial. The Leyden jars should be in circuit.

In more obstinate cases a bougie electrode (Fig. 131) can be introduced per rectum, the other pole being on the abdomen, and a faradic current passed. In cases of obstruction, where the bowel is dilated, and the muscular



FIG. 131.—RECTAL ELECTRODE.

fibre paretic, galvanic currents are the most serviceable. It was stated in the chapter on physiology that stimuli of some duration were the best for involuntary muscles; this is still more the case when these muscles are partially paralyzed. A faradic current may, under these circumstances, have little or no effect; while an interrupted galvanic current, especially if allowed to flow for a short time between the interruptions, and if occasionally reversed, may produce vigorous contractions. The effect will be enhanced if one pole be introduced per rectum, but the difficulty has always been to avoid electrolysis and destruction of the wall of the bowel at the point of application of the electrode. Boudet solved this problem by increasing the area of the intestinal electrode with warm salt water.



A catheter rectal electrode, insulated except at its tip, is used ; this is passed up the bowel as far as it will go, and is connected with the positive pole ; the negative pole, of large size, rests upon the abdomen. When all is ready, about 2 pints of warm, slightly-salted water are allowed to flow through the catheter into the bowel, and the current is turned on, and raised to about 30 m.a. In five minutes' time it is brought back to zero, reversed, and then increased again. The patient is desired to resist as much as possible all impulses to empty the bowels. The current is now interrupted every twenty seconds for as long a time as the patient can bear it ; this cannot be continued as a rule for more than five to ten minutes, owing to the irresistible impulses to empty the bowel which follow the reversal and interruptions of the current. The electrode is at this moment to be withdrawn. If the patient now has a proper motion, the condition has been temporarily overcome ; if he has not, the application should be repeated in about eight hours' time ; if after four such applications no relief ensues, the question of laparotomy must be considered.

Where there is reason to suppose that the bowel is ulcerated, this treatment should not be undertaken ; peritonitis has been occasioned by the passage of the fluid through a perforation. Accidents are, however, very rare, and the proportion of successes about 70 per cent. in 250 recorded cases (Larat, p. 327).

Herschell recommends the triphase current with one pole in the rectum for atonic constipation.

### **Prolapsus Ani and Hæmorrhoids.**

Prolapsus ani, and relaxation of the sphincter, can commonly be rapidly improved by a few applications of the faradic current. (For hæmorrhoids, see High-Frequency Currents, p. 414.)

## DISEASES OF THE GENITO-URINARY ORGANS.

### Enuresis Nocturna.

This, when not a symptom of calculus, thread-worms, or other disease, usually yields very rapidly to faradic or galvano-faradic applications. One pole may be placed above the pubes, and the other over the perineum or sacrum. If a successful result be not obtained, a catheter electrode insulated except at its point should be introduced into the bladder, and connected with one pole, while the other rests upon the abdomen. The faradic current should be used.

### Paralysis and Atony of the Bladder.

These conditions, if functional, may be successfully treated in the same way, or by Boudet's method. A catheter electrode is introduced, the bladder half filled with warm salt water, and a current of 10 m.a. passed ; after two or three minutes it is reversed, and then interrupted.

If the paralysis is due to myelitis, the spinal cord should also be treated. The results are naturally much less favourable.

### Spermatorrhœa and Impotence.

The treatment should be general and local.

General treatment : Static electricity or the faradic bath ; galvano-faradization of the lumbar and cervical regions of the cord. Moral measures.

Local treatment : Faradization of the perineum, testicles, and inner sides of the thighs, or the faradic brush or static friction. Static sparks are injurious in spermatorrhœa (Vigouroux).

### Amenorrhœa.

In cases in which it is desirable to relieve this condition, electricity will prove very efficacious.

Static electricity, with sparks drawn from the lumbar region of the cord, the hypogastrium, and the loins, is the method that is at once quickest, most reliable, and most easily carried out. Galvano-faradization from the lumbar to the suprapubic regions, with large plate electrodes, for ten minutes a day, especially at the time the menses should appear, is recommended by Dr. de Watteville. In more obstinate cases one pole may be placed in the vagina or uterus, and the other over the back or abdomen, and a weak interrupted galvanic or faradic current passed.

#### **Uterine and Ovarian Pain.**

The best electrical agent to relieve the backache, dragging sensation, and pains that women are subject to appears to be the faradic current. Apostoli recommends a secondary coil of long thin wire, so as to obtain as much tension (as many volts) as convenient. He remarks that to relieve pain, we have, as he was the first to point out, a powerful resource in faradization. The currents of tension, applied as much as possible in the cavity of the uterus, are sedative in a high degree.

‘They will be found,’ he says, ‘of almost certain arresting power in simple ovarian neuralgia, calming only in cases of pain from other sources, and but of very little service in the acute and suppurating forms of peri-uterine inflammation.’

High-frequency currents may also be tried (see Part VI.).

Drs. Aust-Lawrence and Newnham prefer the faradic current. In an article in the *British Medical Journal*, November 28, 1891, they remark that the secondary faradic current produces a marked diminution in the sensitiveness of the parts in the course of the current, especially those to which the electrodes have been applied. If it is a case of a painful and prolapsed ovary that at the beginning of the sitting cannot be touched without inducing great pain, it can be firmly pressed on at the end of the sitting without causing pain, and this condition

will last some hours after the application. To obtain permanent relief, the application must be made night and morning for about ten days, then daily for about twenty more days ; at the end of this time, in the majority of cases, the nerves in the painful organs or tissues cease to have the power of conveying pain, yet the organs or tissues still remain as they were before the electricity was used. In the majority of cases, where a woman complains of pelvic pain, one can relieve her to a very large extent, and remove entirely, in a large number of cases, the pain of which she complains.

Apostoli uses a bipolar electrode (Fig. 125), which is introduced into the uterus, and the current's effects concentrated ; but external applications—one pole over the sacrum and the other on the perineum or in the groin—are often sufficient. Sometimes a better effect is produced by the introduction into the vagina of one of the poles. (For treatment of cervical cancer, see High - Frequency Currents.)

#### **Subinvolution.**

The uterus may be made to contract and the tone of its muscle be improved by unipolar or bipolar internal faradization. This treatment, recommended by Drs. Grandin and Apostoli, seems rational, and deserves a trial.

The faradic current, if at hand, is a powerful means of checking post-partum hæmorrhage. One pole should be introduced into the uterus, and the other placed over the abdomen. The galvanic current, with quick reversals and interruptions, should prove even more efficacious.

#### **Galactagogue Effects.**

Faradic and static electricity have been recommended to promote the secretion of milk. Bipolar faradic applications of a quarter of an hour, and frequently repeated, may be tried (De Watteville, Erb, Beard, and Rockwell).

**DISEASES OF THE SKIN.**

Electricity may here be of service in two principal directions : applied generally, it may modify and improve the constitutional condition, give tone to the sensory and trophic nerve terminations, and influence the central nervous system ; applied locally, it may relieve itching and pain, and, by the liberation of acids and alkalis, produce their proper astringent and cauterizing actions. It is thus of service not only in skin diseases of neurotic and constitutional origin, but also in the more local inflammatory conditions. (For treatment by Röntgen rays, Finsen light, high-frequency currents, and radium, see Chapter IV., Part VI.)

**Eczema.**

The remarkable results obtained with the alternating current bath by Drs. Larat and Gautier have already been referred to (see p. 274).

Drs. Beard and Rockwell speak with great confidence of the treatment by central galvanization. This, without any local application, will sometimes relieve the itching and burning at once, and eventually produce a permanent cure. Local galvanization is also of much service.

**Acne.**

Labile galvanization, with the kathode over the affected area, the faradic brush, or electrolytic puncture of the pustules and dilated vessels by a kathodic needle, may be tried.

**Alopecia Areata.**

Bipolar stabile weak galvanic currents, the faradic brush, or static sparks (Ranney), may be of service. De Watteville has obtained good results by the first method. High-frequency currents have been of some service to the author.

### Urticaria.

Liebig and Rohé remark that œdema, urticaria, and neurotic bullous eruptions can be successfully aborted by means of the galvanic current, the anode being applied to the spine, and the kathode to the seat of the outbreak.

Chilblains also often yield to galvanization or faradization, especially to a local faradic bath.

Erb reports that F. A. Hoffman found that chilblains disappeared in a marvellous manner after from two to five applications of the faradic current.

General treatment in these neurotic affections should not be omitted.

### Herpes.

The treatment of this condition has already been referred to.

Beard and Rockwell, from the observation of several cases, draw the following conclusions :

‘ 1. That the pain of herpes, no matter where the seat of the eruption may be, is generally susceptible of speedy and effectual relief by the use of the galvanic or faradic current.

‘ 2. That when the eruptions take place on the head (herpes frontalis), the galvanic current has greater power to relieve the pain than the faradic.

‘ 3. The electrical treatment, besides relieving the pain, seems to shorten somewhat the acute stage, to break the force of the disease, and to modify the scarring ’ (‘ Medical and Surgical Uses of Electricity,’ p. 535).

### Pruritus.

Either the faradic brush, general faradization, or the faradic bath is indicated.

### Elephantiasis Arabum.

Professor Silva Arango and Professor Moncorvo, of Rio de Janeiro, have successfully treated many cases of this

disease by the combined use of electro-puncture, the galvanic and faradic currents.

The hypertrophied tissue is electrolyzed from time to time by the introduction of needles connected with the negative pole; and galvanic and faradic applications, combined with massage and pressure, are practised during the intervals.

### Parasitic Affections.

The cataphoric properties of the continuous current have been utilized to carry parasiticide solutions down into the hair follicles and true skin. Harries and Lawrence state that a few sittings have sufficed to cure disease of considerable standing. The anode, preferably of carbon, should have its covering well moistened with the bichloride of mercury (unless a special cup-shaped cataphoric electrode be used), and should be placed over the diseased area. The kathode should be in the vicinity. What really occurs it is difficult to say. The solution may be decomposed, the chlorine appearing at the surface of the electrode and the mercury on the skin, and the latter may then be mechanically transferred into its deeper layers, where it may enter into fresh combinations with the chlorides, etc., of the tissues. But if the current be weak, mercurous chloride may be deposited on, and carried into, the skin.

There can be no doubt about the possibility of passing mercury directly through the skin by cataphoresis; this has been done by Gärtner, who used galvanic baths in which the bichloride was dissolved, and who afterwards detected the mercury in the urine. The amount absorbed appears to depend mainly upon the strength and duration of the current (*Revue d'Electrothérapie*, February, 1892).

Dr. Gautier has introduced a method which he terms 'interstitial electrolysis.' He has employed it successfully for sycosis, lupus, strumous abscesses, actinomycosis, etc. Copper needles connected with the positive pole are thrust into the diseased tissues. During the passage of the

current the copper dissolves to form with the nascent oxygen and chlorine of the tissues the oxychloride of copper, which, diffusing into the surrounding parts, exercises a powerfully antiseptic and caustic action. At other times he employs iodide of potassium, which is first injected into the diseased area, and then electrolyzed. The nascent iodine now acts as a powerful antiseptic and astringent. He recommends the following solution :

Potassium iodide	-	-	-	1 gramme.
Glycerine	-	-	-	5 grammes.
Aqua destillata	-	-	-	20 grammes.

In a case of sycosis of the upper lip, which had resisted for more than two years all other treatment—parasiticide ointments, scarification, epilation, etc.—he obtained by eighteen sittings, using the solution just mentioned, most successful results. A case of extensive actinomycosis of the face yielded in three weeks to similar treatment (*Revue d'Electrothérapie*, October, 1891). The Röntgen rays or ultra-violet light are likely to be of service in this direction. Dr. Leduc, of Nantes, has recently reported the complete cure of a case of rodent ulcer by the introduction of zinc ions, using an anode of zinc wrapped in cotton wool wet with zinc chloride solution ; the rodent ulcer disappeared after one application. The author has recently tried Leduc's method for an epithelioma of the cheek. The patient has had three applications of ten minutes each with 15 m.a., and some benefit has resulted ; but the pain produced is a serious drawback to the operation.



CHAPTER VI  
THE ELECTRIC CAUTERY AND LIGHT

**The Electric Cautery.**

THE best types of cells and their arrangement for these purposes have already been described.

Fig. 132 represents Dr. Schech's universal cautery handle. It is provided with a trigger for opening and closing the circuit, so as to allow of the instrument's introduction when cold.

The cautery itself is made of platinum, which, being a poorer conductor than the copper connecting wires, can

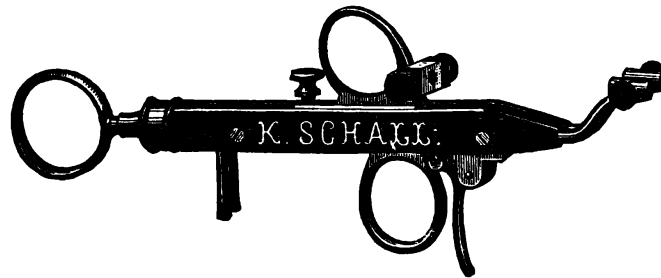

FIG. 132.—DR. SCHECH'S GALVANO-CAUTERY HANDLE.

be brought by the passage of a current of sufficient strength to the desired temperature. (By Joule's law the heating effect of a current depends upon the resistance, multiplied by the square of the current's strength.) The platinum should be maintained at a steady red heat by means of a German silver wire rheostat (see p. 99); if it be hotter than this, hæmorrhage may follow. The full resistance of the rheostat should be put into the circuit

when the current is first turned on, and then gradually diminished by manipulation of the sliding contact until the right temperature is attained. The incautious passage of too strong a current will fuse and destroy the platinum. When accumulators are used, a rheostat is indispensable, but in the bichromate of potash cell the current-strength can be adjusted by raising or lowering the zincs. The commutator described on p. 106 will also serve as a convenient rheostat. The platinum burners are made of various shapes and thicknesses. Sometimes a platinum wire snare, which can be drawn in by means of a sliding arrangement on the handle, so as to gradually cut through the base of a tumour, is used.

The rheophores used in cautery operations should be large, so as to offer little resistance; if they are too small, they would themselves become heated, and uselessly weaken the current.

The resistance of the burners and rheophores together varies, as a rule, from about 0.04 to 0.06 ohm, and a current-strength of from 10 to 20 ampères is required. This is best furnished by bichromate of potash, or accumulator cells connected in parallel, or partly in parallel and partly in series; if a long wire snare is to be heated, three or four large cells may have to be connected in series. A reference to the examples of Ohm's law in a previous part of the book will make this clear.

### Lighting Purposes.

The internal introduction of a small incandescent electric lamp for the purpose of illumination and visual examination of the various cavities of the body is proving itself of great utility.

The stomach, rectum, vagina, bladder, urethra, and larynx can all be examined by this method.

Fig. 133 is that of Dr. Semon's electrical laryngoscope. A thin carbon filament is enclosed inside an exhausted glass bulb, and raised to incandescence by the heating effect of the current. The light afforded is purer, whiter

and more complete than any other artificial one. (Carbon both absorbs and radiates all the light rays; its spectrum is a continuous one.) A German silver wire rheostat is also of service here. The resistance of the small lamps varies from 7 to 20 ohms, and the current-strength



FIG. 133.—ELECTRICAL LARYNGOSCOPE.

required to bring them to full incandescence is from 0.5 ampère to 1.5 ampères. They therefore require only about one-tenth of the current-strength necessary for a cautery, but a greater E. M. F. to overcome their resistance. This can be supplied by from five to ten of the cells already mentioned connected in series.

### The Cystoscope.

This is an instrument for examining the interior of the bladder by means of a telescope and the internal introduction of a small incandescent lamp (Fig. 134).



FIG. 134.—DR. HURRY FENWICK'S CYSTOSCOPE FOR ANTERIOR WALL.

For the following description I am indebted to Mr. David Wallace, C.M.G., F.R.C.S. Ed. :

‘ The cystoscope is shaped like a sound, and consists of

three parts—the beak, the shaft, and the eyepiece. Running from the eyepiece to the beak there are two hollow tubes, an inner and an outer. The former serves to connect the electrodes of a battery (the source of E. M. F.) with the lamp (the source of light). The beak is a hollow cap, with a window of rock crystal, and contains a small incandescent lamp, from which the light for illumination is emitted. In the anterior instrument, at the concavity, where the shaft and beak join, there is a prism, which refracts the rays of light from the object looked at on to the end of a telescope, which passes from the eyepiece of the instrument down to the junction of the shaft and beak. In the posterior instrument no such prism is necessary, but merely a plate of glass, as the object to be observed is in line with the telescope and the observer's eye.

‘ The ocular end has screws to connect the electrodes of the battery with the instrument, a screw (C) to open and close the circuit, and on its rim, opposite the concavity of the instrument, a small knob, which indicates the position of the window in the cap, and thus enables the observer to know which part of the bladder is under examination.

‘ The instrument has been variously modified in its details, but the original principle remains unchanged. Some of the modifications are improvements, and there are three which I think especially worthy of mention :

‘ 1. The increased length of the instrument, which is of value in patients who have enlarged prostates. The increase in length entails, however, the disadvantage that the field seen is smaller.

‘ 2. The addition made by Berkeley Hill of connecting an irrigator to the instrument without greatly increasing its calibre. This is of value when bleeding is profuse, for in such cases the fluid in the bladder may become discoloured so rapidly that examination is rendered difficult, if not impossible. By modifications of Berkeley Hill's instrument, or with it, the fluid can be changed and the

difficulty alluded to overcome without the withdrawal of the instrument.

‘3. The modification suggested by Fenwick, which enables the instrument to be rotated within the bladder while the part to which the electrodes are attached remains fixed in one position (see Fig. 134).

‘To use the instrument we require to prepare the patient in the same way as for any other instrumentation of the bladder. He should be in bed, or placed on a table, in the recumbent posture. The bladder has 6 to 10 ounces or more of a clear fluid introduced into it. This must be done very gently to avoid inducing hæmorrhage, which readily occurs in some cases of neoplasm, one of the conditions in which cystoscopy is of especial value. If the fluid drawn off before injection be discoloured by blood or pus, the bladder should be washed out until the fluid comes away without discoloration.

‘When the bladder has been thus treated the patient is brought down to the end of the bed or table with, preferably, his legs hanging over the end. The cystoscope, having been previously tested to ascertain that it is in good working order, is oiled, and introduced into the bladder with the electric circuit open. When the beak is fairly in the bladder the eye of the observer is applied to the ocular end, and the circuit closed, after which, with gentle movements, the whole interior of the bladder wall is carefully and methodically examined, especial attention being given to the examination of the trigone, at or near which many pathological conditions are apt to present themselves. The ureteral openings should be carefully noted, and if possible the appearance of the urine as it passes from them should be observed.

‘The upper three-fourths of the bladder can be most readily investigated, the lower fourth being more difficult to see in cases where enlargement of the prostate is present. When the examination has been completed the electric circuit is opened and the instrument withdrawn. When not surrounded by fluid the cystoscope rapidly

becomes heated, and it is imperative, therefore, both when introducing and withdrawing the instrument, to shut off the electro-motive force.

‘An anæsthetic is not invariably required, but in nervous patients or in sensitive bladders anæsthesia is advantageous.

‘Time has proved the great value of cystoscopy, and genito-urinary surgery has advanced enormously, both as regards diagnosis and treatment, since its introduction.



FIG. 135.—PHANTOM FOR CYSTOSCOPIC PRACTICE.

In particular, perhaps, this applies to renal surgery, as surgeons now have a means of differentiating renal from vesical hæmaturia with certainty, and also they are able to tell which is the affected kidney. Further, the introduction of cystoscopes to enable catheterization of the ureters to be performed has facilitated the examination of the urine from each kidney, so that the functioning power of each can be determined. Several forms of cystoscope can be used for this purpose, but one of the best is that known as Albarran's, which has the ureteral catheter

on the same side as the light, and by a special joint can have its angle changed while within the bladder.'

*The urethroscope* for examination of the urethra has the light external. It is valuable in cases of gleet, as in intractable cases the exact site of the lesion may be seen, and topical remedies be applied under the eye of the surgeon.

Fig. 135 represents the dummy phantom of Professor Dittel for practising with the cystoscope. For further information as to the morbid appearances which can be observed by this instrument, or its utility in diagnosis and prognosis, the reader may consult Mr. Hurry Fenwick's 'The Electric Illumination of the Bladder and Urethra'; Mr. David Wallace's papers, *Ed. Med. Journal*, February, 1890 and 1892; 'Encycl. Medica,' Art. 'Cystoscopy.'

The gastroscope for examining the condition of the stomach wall, the rhinoscope for the nasal cavities and naso-pharynx, etc., depend upon the same principles, and do not require especial mention. In the gastroscope the lamp is cooled by a current of air instead of by a current of water, and the stomach may also be dilated by this means.

### The Electro-Magnet.

Fig. 136 represents Mr. Hardy's electro-magnet for removing particles of steel or iron from the eye. Pole-



FIG. 136.—ELECTRO-MAGNET FOR OPHTHALMIC PRACTICE.

pieces of various sizes may be fitted to it as required. At the other extremity are two terminals for the attachment of the rheophores of a galvanic battery. Large active cells (bichromate or accumulators) give the most attrac-

tive power. A key is provided for closing the circuit. The pole is brought as close as possible to the foreign

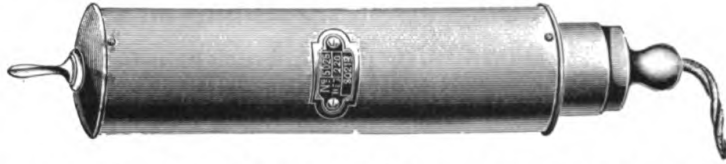

FIG. 137.—SIMILAR MAGNET WOUND FOR ELECTRIC LIGHT CURRENT.



FIG. 138.—HAAB'S ELECTRO-MAGNET

body, and the circuit closed. A slight incision is often of service to enable the pole to be brought nearer, for the



magnetic attraction, *cæteris paribus*, varies inversely as the square of the distance (Fig. 137).

'The Electro-Magnet in Ophthalmic Surgery,' by Simeon Snell (Churchill), may be consulted by those desiring further information.

In cases in which the small portable electro-magnet has failed, the author has lent ophthalmic surgeons a large powerful laboratory electro-magnet (the iron core has a diameter of  $1\frac{1}{2}$  inches); by placing a pointed pole-piece upon this great magnetic intensity is obtained. There are, however, difficulties in its use. Switching the current on and off suddenly may help by jerking to move the embedded fragment. Fig. 138 is that of the magnet of Professor Haab. This magnet takes the current from the main, and exercises a very powerful attraction on any ferro-magnetic body (p. 20) of sufficient mass.

# PART VI

## RÖNTGEN X RAYS

### CHAPTER I

THE wonderful discovery of Professor Röntgen, which was made known to us in January, 1896, had been preceded and led up to by the labours of Crookes and Lenard. Crookes had succeeded in emptying a glass tube of its air more thoroughly than had ever been done before : he brought the pressure of the residual air down to about the  $\frac{1}{1000000}$  of an atmosphere, and had studied the phenomena presented by an electric discharge passing through the tube ; this discharge, which proceeds from the kathode (negative pole), is visible at a certain stage of the exhaustion, and was called by him the kathode stream. He studied this kathode stream *in* the tube, and concluded that it consisted of material particles\* shot off from the negative pole with almost inconceivable velocity—a velocity of about 250,000 yards a second. But it was left to Lenard in 1894 to succeed in passing this kathode stream *outside* the tube through an aluminium window ; he found that these rays travelled better in a vacuum than in air, that they produced phosphorescence of suitable materials, would pass through substances opaque to ordinary light, and affect a photographic plate. In these particulars the Lenard rays resemble X rays, but they differ from them in being deflected by a magnet ; hence

\* Now termed 'electrons,' and regarded as consisting of units of negative electricity.

the kathode rays must be corpuscular, while the X rays are ethereal undulations. Lastly, Professor Röntgen discovered that, if the vacuum be increased, a variety of rays was given off from the tube which were more powerful in many respects than the kathode rays, and which were quite unaffected by the strongest magnet. These rays he termed X rays. Professor Röntgen further popularized his discovery by finding that though these rays would pass easily through the skin, yet that the bones were somewhat opaque to them, and that thus a shadow of the bones could be photographed, or even seen on a suitable phosphorescent screen. The immense importance of this discovery in practical medicine and surgery was at once realized, and scientific men all over the civilized world began to repeat his experiments and to endeavour to improve the process. The greatest advance that has since been made has been the invention of the focus tube by H. Jackson, of King's College, London. In the earlier Crookes tubes the kathode stream impinged upon the glass, and the X rays took their origin from that point, the point at which a green-yellow phosphorescence of the glass is produced. Jackson discovered that if a piece of platinum was used as a target for the rays instead of the glass, the penetrative force and number of the X rays was very much increased, and that also sharper shadows could be obtained.

What is the nature of the X ray radiation? If we look at the ordinary visible spectrum of white light, we see the various colours of the rainbow, but we know that there is also an invisible spectrum which extends far below the red on the one hand, and beyond the violet on the other. The invisible rays below the red are called the infra-red; they are the radiant heat-waves which give us the comfortable sense of warmth we feel when we sit opposite an open fire. They are of longer wave-length than the visible rays, and they do not pass so easily through glass; we can thus use a glass fire-screen to keep them off. There are also other rays below these, which are of still longer wave-length,

and which we cannot detect by our unaided senses. They are known as the Hertzian rays, after the late Professor Hertz, who was the first to make a thorough experimental study of them.

To recognise the presence of these very long waves, we must be provided with artificial detectors or eyes, and one of the best of these is founded upon the fact discovered by M. Branly, that a bad electrical contact is made into a good one when Hertzian waves fall upon it. The author exhibited some experiments of this nature, using powdered aluminium, before the Edinburgh meeting of the British Association in 1892, and Professor Oliver Lodge and others have since constructed a variety of such electrical eyes.

If we leave these long invisible rays, and ascend through the infra-red or radiant heat-waves, we come again to the visible spectrum, and, still ascending, we pass through the various prismatic colours from red to violet, until the light again fades away and we are in the presence of ultra-violet light. The wave-length of the rays has progressively diminished as we have ascended, so that whereas the Hertzian waves may be many miles in length, the ultra-violet are less than the  $\frac{1}{80000}$  of an inch.

All these forms of radiation are only varieties of one phenomenon ; they are all electro-magnetic disturbances of the ether. Thus, they all travel with the same velocity and obey a common law in suffering reflection, refraction, polarization, and interference.

Though the ultra-violet rays are normally invisible, they can be made visible by what is termed fluorescence ; if, for instance, a piece of glass coloured with uranium be held in these rays, it will shine with a greenish-yellow light. Further, these rays will powerfully affect a photographic plate, and under certain circumstances will discharge an electrified body.

Now, the X rays probably lie beyond these ultra-violet rays—not close to them, but far beyond them. The

X rays are probably due, as the late Sir G. Stokes suggested, to a series of irregular ethereal pulses, analogous acoustically to a noise. They are set up by the impact of the kathode electrons on the platinum target. They travel with the velocity of light, and are polarized (Blondlot), but they cannot be regularly reflected or refracted. One of the most striking properties of the X ray is its power of penetrating opaque objects. The transparency of a body depends solely upon its density; thus the heavier an object is the more opaque it is, and *vice versa*.

#### Mode of obtaining the X Radiation.

The rays are best obtained by passing electrical discharges through highly-exhausted vacuum tubes: so far as our present knowledge goes, one might almost say that this is the only method of obtaining them. Professor S. Thompson is, however, said to have obtained some X radiations by the prolonged use of an arc light. An experiment was made by me to test this. I exposed an extra rapid plate in its dark slide to an arc light at 6 inches distance for fifty minutes; the plate was found on development to be quite unaffected, though it had been warmed by the action of the radiant heat. Professor Thompson has since discovered that the rays given off by the arc light will not penetrate aluminium, and that they cannot therefore be true X rays. Glow-worms, whether glowing or not, give off a radiation resembling the X radiation; the author's experiments with glow-worms were communicated to the B. A., September, 1896. The gamma rays of radium also somewhat resemble the X ray.

To obtain the Röntgen radiation, we therefore require a means of producing the electrical discharges and a proper vacuum tube.

The electrical discharges may be obtained from a Tesla apparatus, from an induction coil, or from a static electrical machine—*e.g.*, a Wimshurst machine (*vide* p. 11).

The Tesla apparatus was more largely used for this purpose at first than it is now. With the present form of focus vacuum tube, it is not of the service that it was

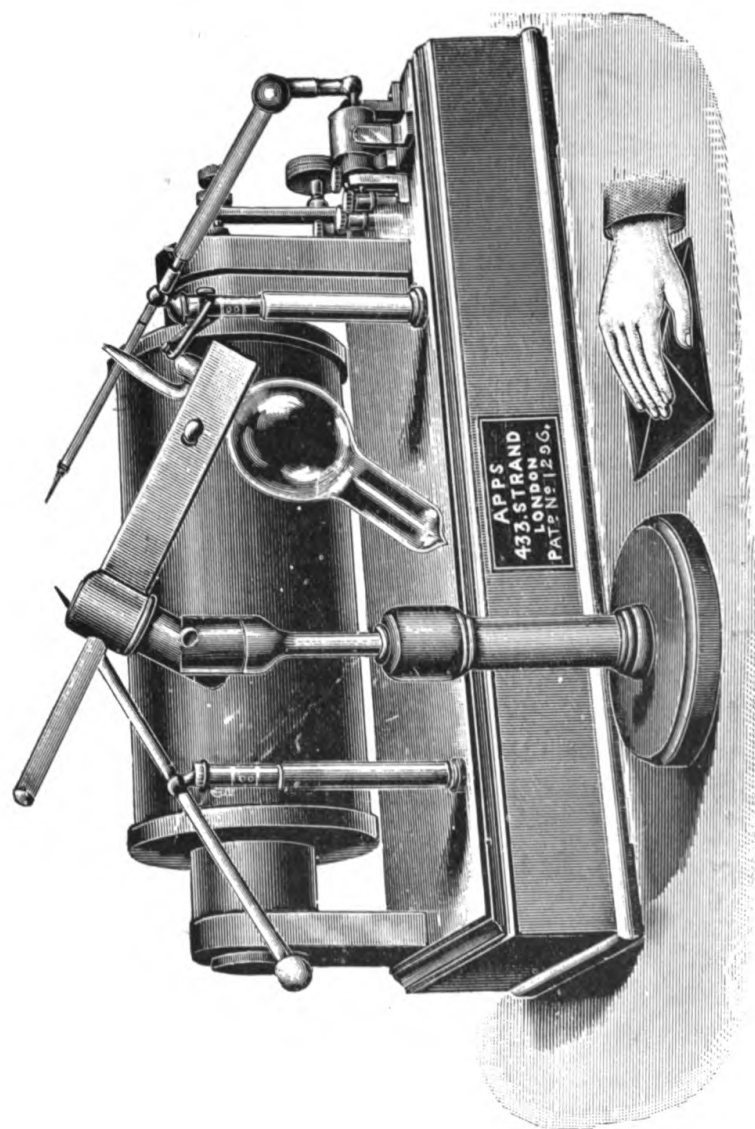

FIG. 139.—INDUCTION COIL; 10-INCH SPARK.

with the older form of tube ; it would in the latter case often cause a brisk radiation of X rays when an ordinary induction coil was insufficient. It is, however, more troublesome and difficult to work than a simple induction coil, and tubes are more likely to be punctured by its

use. (The reader may consult Chapter V., Part VI., for a description of the Tesla apparatus.)

Undoubtedly the best and simplest method of obtaining the electrical discharges is to make use of a good induction coil (*vide* Chapter IX., Part I.). This should be of large size; nothing less than a 6-inch spark coil is of much use, and a 10 or 18 inch spark coil is better still. For infirmaries, or where much work is to be done, an 18-inch spark coil is best.

A great deal depends upon the quality of the coil and the construction of the contact-breaker; these should be of the best workmanship, and the platinum contact should be large and thick. Gaiffe, Rue St. André des Arts, Paris, supplies an arrangement whereby the platinum contact is continually rotated, so as to avoid a too long-continued action at one point. The 'Vril' contact breaker, sold by Watson, of High Holborn, is an improved form of Neef's hammer, which gives more powerful discharges, and is to be preferred.

Too great stress cannot be laid upon the necessity for obtaining a really first-class coil. A small coil of good make will be of more service than a large one of inferior make.

The important part that the contact breaker plays in obtaining powerful electrical discharges has not hitherto been sufficiently recognised. The old form of Neef's hammer, though well adapted for small coils, is entirely out of place in breaking the circuit of the large and powerful coils nowadays required; it heats and sticks and burns up exceedingly rapidly, and cannot be used with high voltage currents.

We may classify the other kinds of interrupters into three groups.

1. The mercurial.
2. The electrolytic.
3. Mechanical rubbing contact between solids.

All these can be used with high voltage currents from the mains.

1. Of the mercurial there are three principal forms.

(a) The old form of *dipping contact* (Fig. 140).

The disadvantages of this instrument are that it is too slow, it cannot in its simple form give more than fifty breaks a second, a reciprocating motion cannot be made as rapid as a purely rotary one, and, further, the mercury is thrown into waves, so that a complete break at high speeds is not ob-

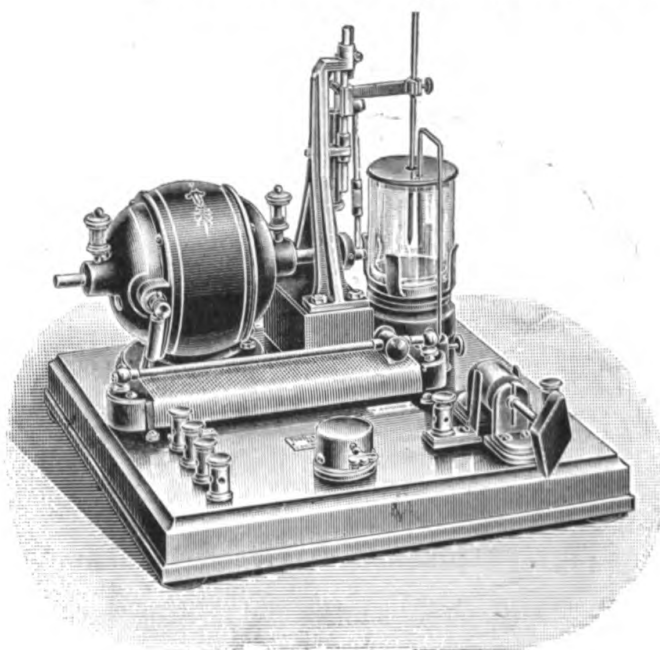

FIG. 140.—DIPPING INTERRUPTER.

tained; still, it is not liable to get out of order, and only a small amount of mercury is required for it. For hospital use it is one of the best.

(b) *The Mackenzie Davidson interrupter*, supplied by Cox of Cursitor Street, London (Fig. 141), is an excellent one; it has a purely rotary motion, and can be made to close and open the circuit with any desired degree of rapidity.



It is thus superior to the dipping contact instrument, particularly when it is desired to run the coil at the high voltages obtainable from the main, but the mercury is still liable to be thrown into waves, so that the break is not so sudden as it might be. The mercury becomes pulverized and slowly churned up with the petroleum, and is unrecognisable as mercury. Further, more mercury is required than for the dipping instrument, and there is a difficulty in insulating the

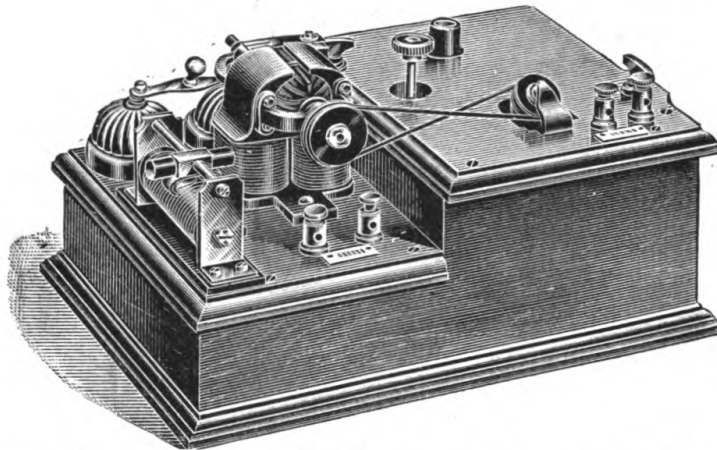

FIG. 141.—MACKENZIE-DAVIDSON INTERRUPTER. ]

paddle shaft from the motor without weakening the mechanical efficiency.

(c) *The mercury jet interrupter.* The contact in this instrument is made by directing a jet of mercury against a revolving cylinder (Figs. 142, 143). There is a later form in which the jet is broken by two revolving fibre arms.

This is a good and safe interrupter, but 20 pounds of mercury are required, and this is a disadvantage, not only from the expense, but also because it makes the instrument essentially non-portable. It is also difficult to clean.

2. The second group of interrupters are *electrolytic* in nature, and were first introduced by Dr. Wehnelt (Fig.

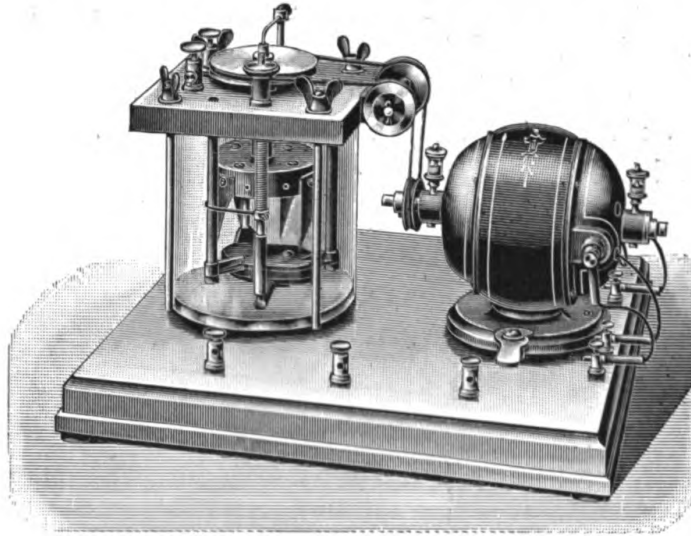

FIG. 142.—MERCURY JET INTERRUPTER.

144). The negative electrode is a lead plate, and the positive electrode is a platinum wire; in later forms three or more platinum wires of varying diameters are

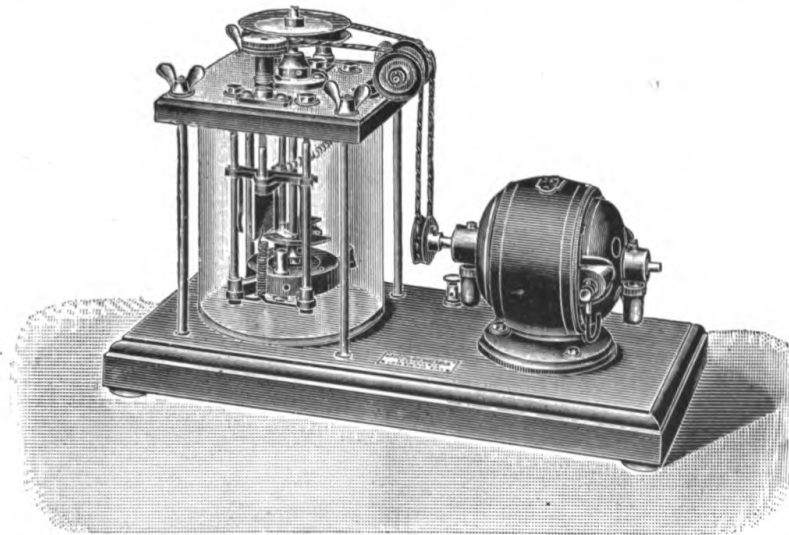

FIG. 143.—MERCURY JET INTERRUPTER. (LATER FORM.)

provided (Fig. 145); these are immersed in dilute sulphuric acid. When a difference of potential of not less than

21—2

30 volts is maintained between these electrodes, the current that passes is interrupted very frequently; it may be about 1,000 times a second. In consequence of this rapid rate of interruption, very powerful secondary discharges are obtained, and these are of an almost continuous nature (Fig. 146). The condensers of the coil should be detached during its use. There are several modifications of the original form, due to Campbell

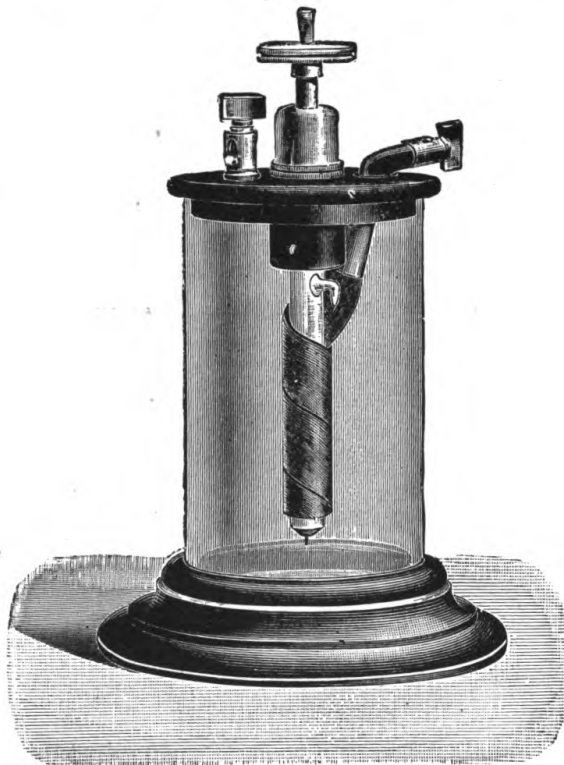

FIG. 144.—WEHNELT INTERRUPTER.

Swinton, Caldwell, and others. There are, however, some objections to its use. It is not a steady and reliable interrupter; sometimes it will give no trouble, while at other times it will scarcely work at all. Further, it soon tires, and the acid becomes hot; the secondary discharges are also very liable to melt the antikathode of the tube. It will not give a long spark. It is largely used in Germany, and can be used with the alternating current as well as with the continuous.

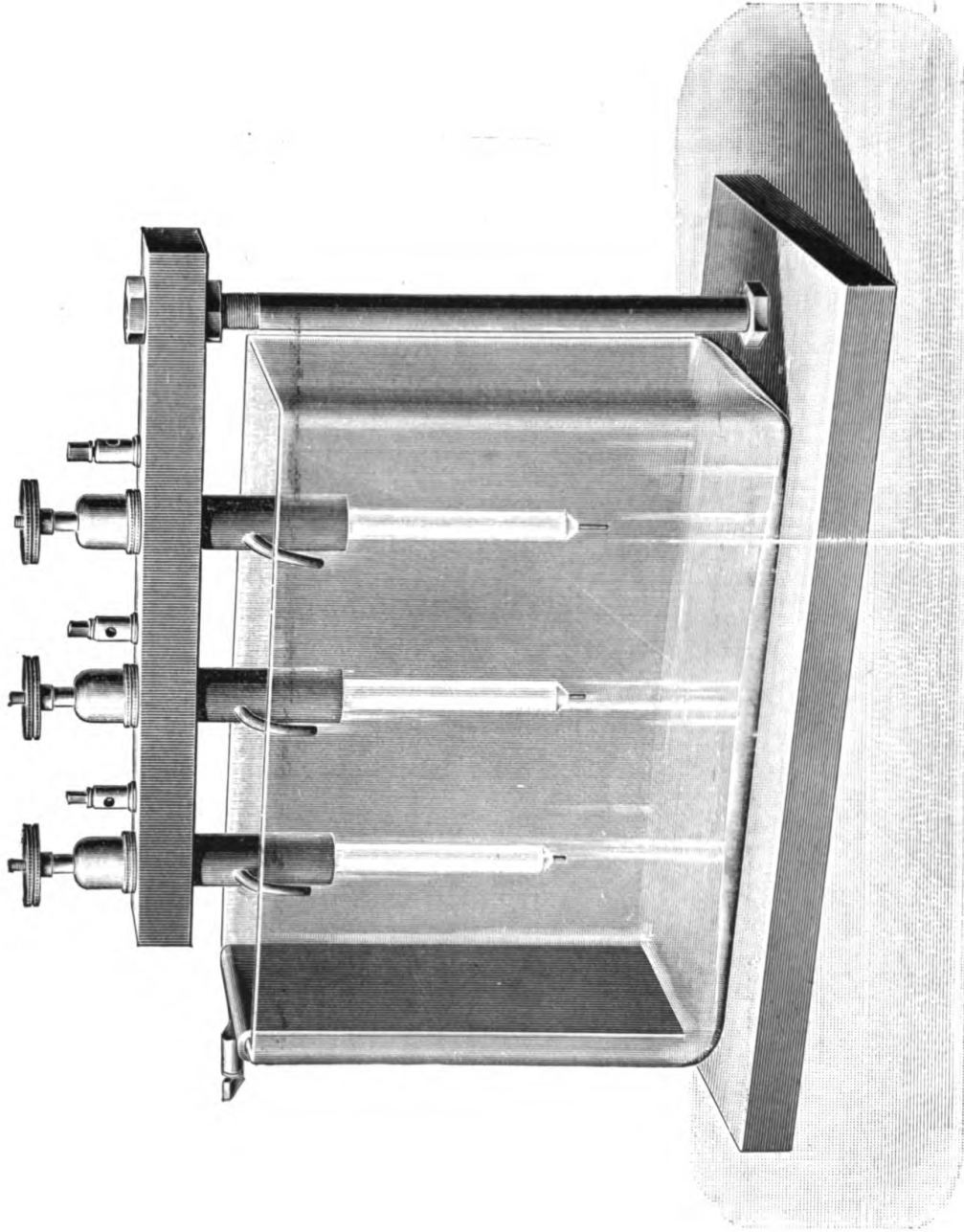

FIG. 145.—WEHNELT INTERRUPTER.

3. Lastly, there are *rubbing contact dry* interrupters—e.g., the Dawson Turner, Contremoulins-Gaiffe, etc. (Figs. 147, 148). Believing that a rubbing contact between solids gives a better contact, and a much cleaner and more sudden break than any contact and break between

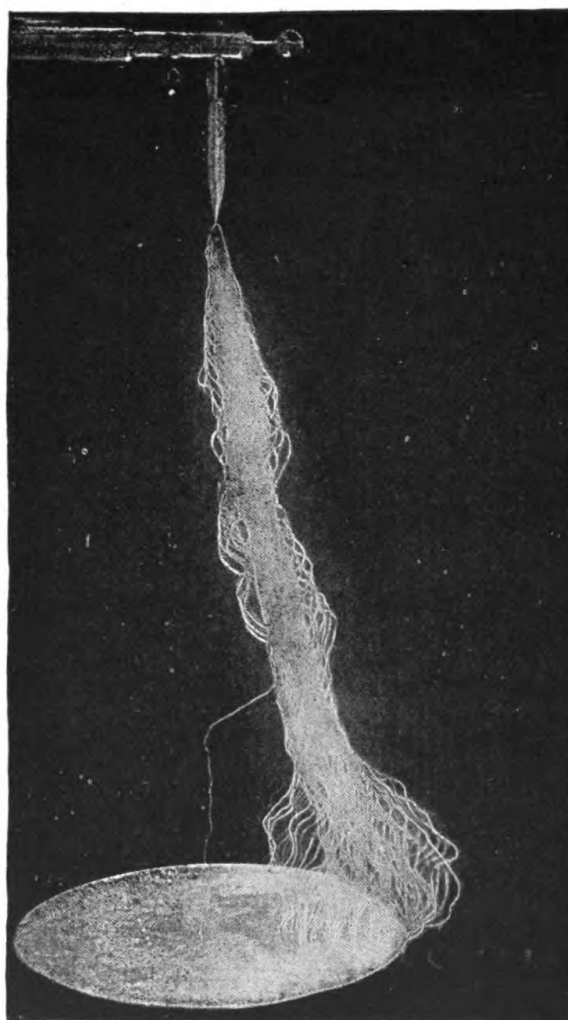

FIG. 146.—WEHNELT DISCHARGE.

a solid and a liquid, I have endeavoured, in the following manner, to get over the difficulties that presented themselves. The chief difficulty to be overcome is the burning away of the surfaces at the point where the current is broken. This can be diminished by immersing

the separating surfaces in alcohol or petroleum, but it cannot be entirely prevented, and a deep pit or groove is soon eaten out of the contact pieces. The pitting can also be diminished by employing platinum or iridium

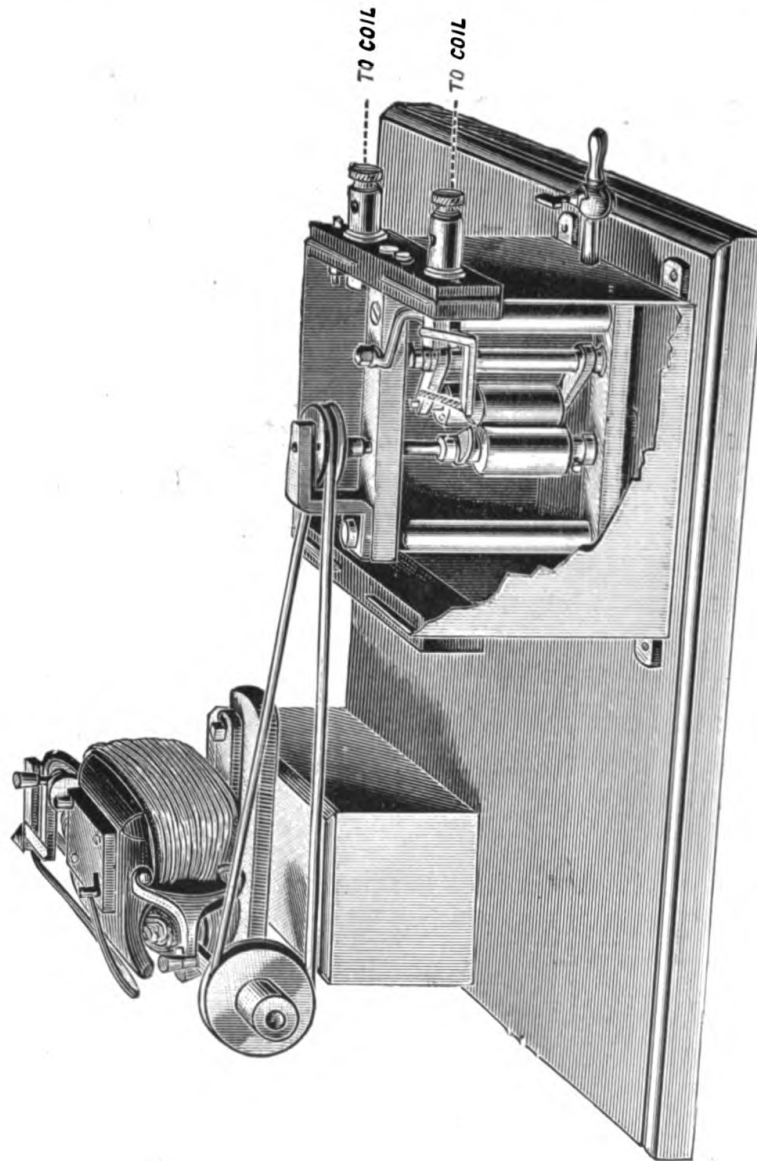

FIG. 147.—DAWSON TURNER INTERRUPTER.

surfaces, but the objection to this is the great expense of these materials. A fixed contact breaker, then, cannot be used for any length of time. I next tried a roller, and found that so long as it was rotated so as to cause it to

continually present a fresh separating surface, it wore away evenly all round, and that it could thus be employed for an indefinite length of time. I now made both the contact pieces of metal rollers, held together by a spring, and I arranged a lifting cam in such a way that while it separated the rollers, it also caused them to rotate, for this latter point is essential. The interrupter can be obtained from Baird, Lothian Street, Edinburgh.

When this interrupter is used in air, the secondary discharges are feeble; immersed in water a much better effect is produced, but by far the best effect is obtained when it is plunged in alcohol or petroleum. The problem of devising an interrupter with solid rubbing surfaces which should not be rapidly destroyed by burning away was now fairly solved. It remained merely to ascertain what the tension of the spring holding the rollers in contact should be, and how large the cam should be (what should be the proportion between the make and break). I found that this was largely a question of the voltage employed; the higher the voltage, the less time need be devoted to the make.

This interrupter is particularly adapted for use with strong currents at high voltages from the mains; but it will also work excellently with accumulators.

It has the following advantages over mercurial interrupters:

- (a) The metallic contact is more perfect.
- (b) The break is more complete and sudden (owing to there being no waves set up in a liquid conductor), no matter how long it may have been running.
- (c) It is more efficient; it gives better secondary discharges for the same number of watts (the same length of discharge is obtained with this interrupter at 3 ampères as with the Wehnelt with 10, the voltage being the same in each case).
- (d) It is more rapid than the dipping contact form; but the chief objection to its use is the noise it gives rise to.



*The Contremoulins-Gaiffe Interrupter.*—This is a rubbing contact interrupter between copper and carbon immersed in an insulating liquid (Fig. 148). An electric motor rotates a cylinder of copper which has been divided longitudinally into two halves; two carbon brushes are pressed by springs against the surfaces of the divided copper cylinder; as the copper cylinder rotates the current is made and broken, and the duration of the

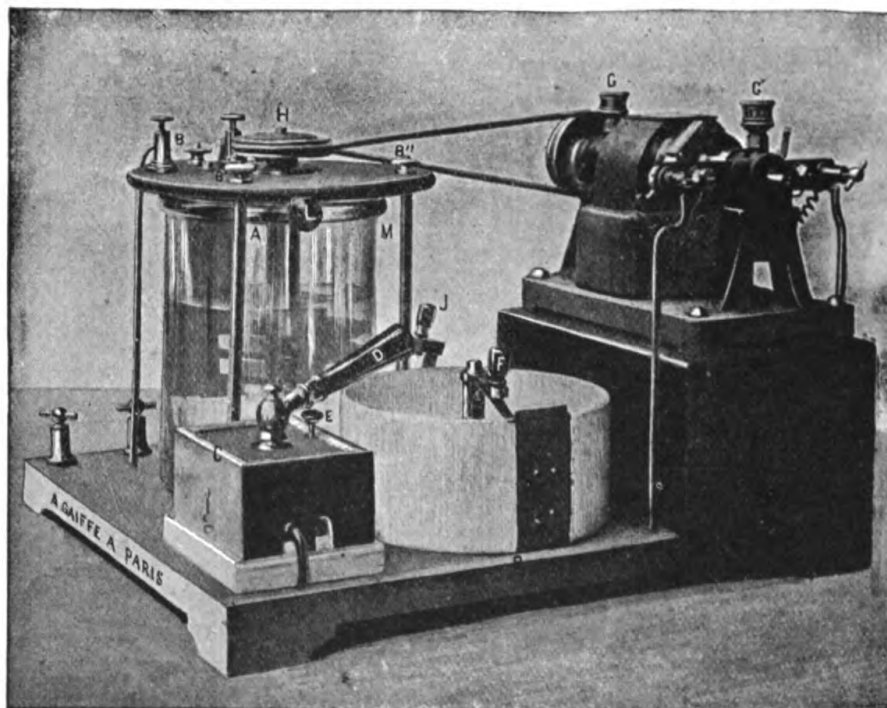

FIG. 148.—THE CONTREMOULINS-GAIFFE INTERRUPTER.

contact can be regulated by altering the position of one of the brushes. This instrument is comparatively silent, but the contact pieces and copper are steadily destroyed by the burning away always occurring at the same place. It will yield as a maximum about 100 breaks a second.

To work the coil, a rheostat attached to the direct current mains or a battery of some sort will be required. Three to twelve accumulators are best (see Part I., Chapter X.), but bichromate or Bunsen cells can also be



used. When there is a convenient means of charging them, accumulators should always be preferred, and it will be prudent in this case to insert a small adjustable resistance in the circuit.

If accumulators cannot be made use of, recourse must be had to cells (see Chapter IV., Part I.).

For long exposures and continued working, Bunsen cells are best, but they are very troublesome, and they give off unpleasant fumes. They will work continuously for some two or three hours, after which they must be taken to pieces and recharged with acid when desired again.

For short exposures and intermittent work, a battery of five bichromate cells, with a lifting arrangement for the

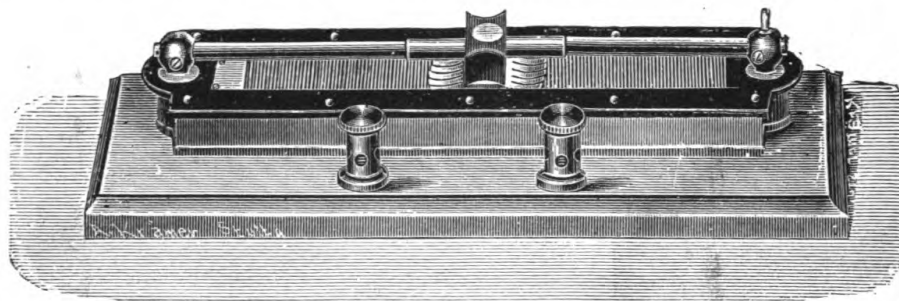

FIG. 149.—ADJUSTABLE RESISTANCE.

zincs, will be suitable. The zinc should be lifted out of the acid when the coil is stopped. This battery gives off no fumes, and is much less trouble to manage than the Bunsen cells, but it will only run for short periods, and is unsuitable for heavy continuous work.

The same may be said of the various forms of dry cells.

If the current from the main is at hand, the coil may be worked directly from it by placing it in shunt with a small portion of a sufficient resistance (Fig. 150; see also p. 126), provided a special high voltage interrupter is used. Fig. 151 is one of a rectifier for use with the alternating current (see also p. 132).

Probably some form of portable accumulators, such as the 'Q' type of the Electrical Power Storage Company, will be found of most service.

Messrs. Norton and Lawrence, in *Nature* for March 18 1897, have suggested that a condenser of 27 microfarads capacity should be directly charged from the main, and then discharged by means of a rotary commutator through an oil induction coil, the primary of which must be made

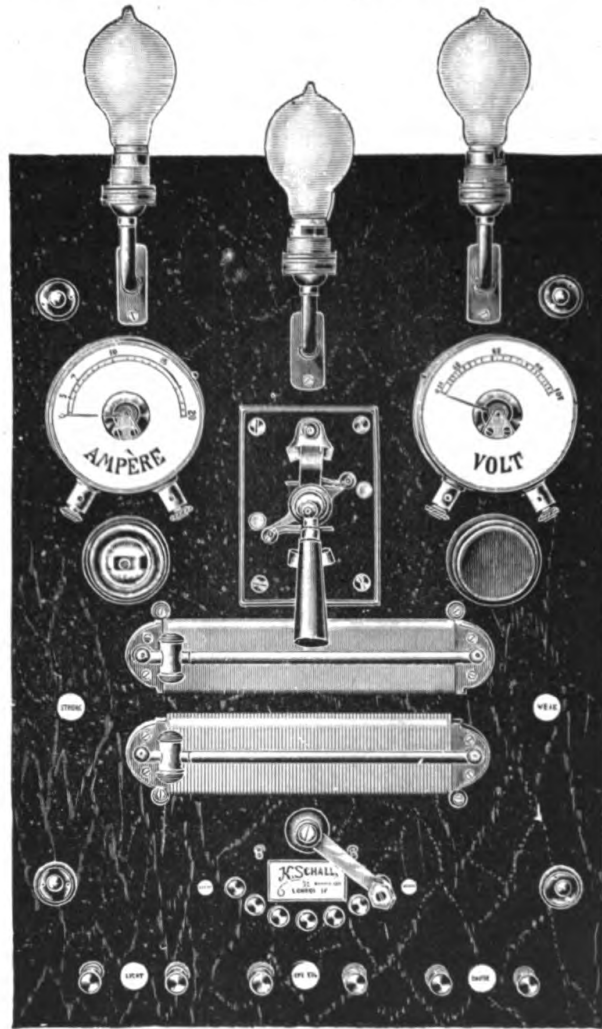

FIG. 150.—RESISTANCE FOR WORKING COILS FROM MAINS.

of very thick wire and of few turns. They claim that this is a more powerful and efficient means of exciting X-ray tubes than any other. Professor Trowbridge's method of working the tube directly from a battery of 15,000 accumulators through a large resistance is the ideal method.

An electrical machine can be used instead of a coil to produce the electrical discharges. Of these, a large multiplate Wimshurst is the best (see p. 11). It will be found better not to connect the terminals of the vacuum tube directly to the prime conductors of the machine, but to allow a small spark gap to intervene on either side. For use with Gaiffe's influence machine a Chabaud-Villard tube with cylindrical terminals and highly insulated connecting wires is provided. The size of these

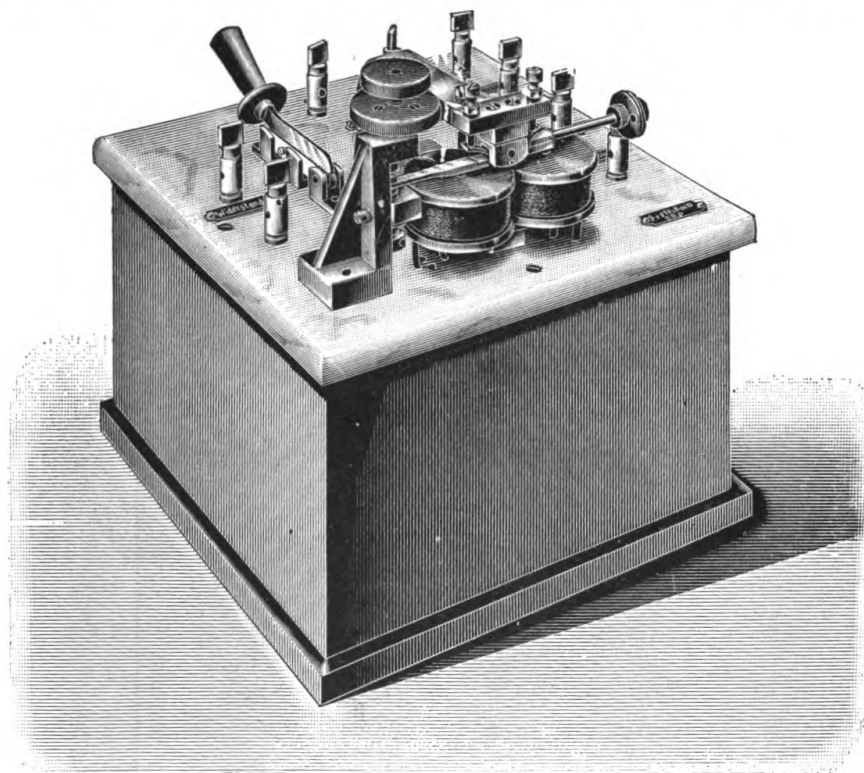

FIG. 151.—ALTERNATING CURRENT RECTIFIER.

spark gaps must be varied until the best effects are produced ; if a continuous discharge be desired, the Leyden jars of the machine should be disconnected. If this be not done, powerful discharges at intervals will be yielded ; these are very tiring to the eye in fluorescent screen work. The chief advantages of the static machine are as follows :

No accumulators, batteries, or interrupters are required, for the machine generates its own electricity.

The wall of the X-ray tube is not made opaque by a deposit of platinum, because the current is continuous in one direction.

The point of emission of the X rays remains fixed, because there is no powerful magnetic field (as there is in the case of the coil) to deflect the kathode stream; shadows on the screen or negative are therefore more sharply defined.

The resistance of the tubes is not raised so rapidly, because the current-strength of the static machine current is very small, and the antikathode is not so much heated.

On the other hand, the machine is absolutely non-portable, so that if patients have to be visited, a coil

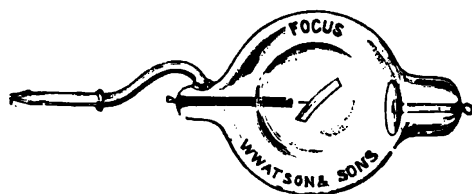

FIG. 152.—DIAGRAM OF FOCUS TUBE.

would have to be kept as well, with its accumulators, interrupter, etc.

If the static machine is to be powerful enough to rival even a small induction coil, a motor will be required to rotate it, and this entails a connection and switch-board to the electric light mains.

The static machine, particularly if it has no sectors (see p. 13), is often very troublesome to start; its output is also affected by the weather, its behaviour being highly capricious in this respect; while a coil starts at once, is always ready, and is quite unaffected by the weather. As a result, operators in Great Britain generally prefer the use of a coil, although at the Salpêtrière Hospital they have used a static machine for the last two years.

The vacuum tube should be a focus one; this is a bulb of glass, into either end of which platinum wires are sealed.

To the extremity of one of the wires, the anode, a small flat piece of platinum is attached, inclined at an angle of  $45^\circ$ ; to the extremity of the other, the kathode, a concave disc of aluminium is fastened, at such a distance from the anode that the kathode rays are focussed upon it. Platinum wires are chosen to pass through the glass, because platinum and glass have nearly the same coefficient of expansion under alterations of temperature, and aluminium wires may be used to connect the platinum wires to the internal electrodes. The glass of which the tube is made must be quite free from lead, because lead is very opaque to X radiation. The tube must now be exhausted, first by an ordinary air-pump, and afterwards by some form of mercurial pump; nothing but a good

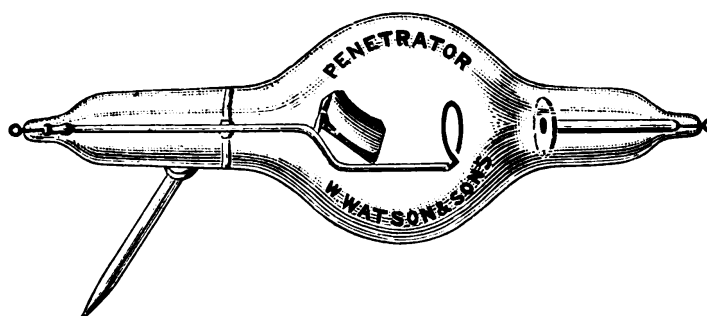

FIG. 153.—DIAGRAM OF WATSON'S PENETRATOR TUBE.

mercurial pump will suffice to produce the high vacuum required, the best mechanical pump being quite inefficient.

The tube should be warmed during the pumping process, and a bulb of phosphoric anhydride should be inserted between the tube and the pump to remove the aqueous vapour. The degree of exhaustion can be estimated by the character of the discharges, which should from time to time be passed through the tube, and by the resistance offered to the passage of the electricity. At the proper degree of exhaustion, that part of the wall of the tube which is opposite the free surface of the anode will be bathed with a greenish-yellow phosphorescence, and the bluish-white light in the body of the tube will

have disappeared. The resistance of the tube to the passage of the electricity at first diminishes until it reaches a minimum, and then rapidly augments again. The pumping process should not be considered complete until the resistance has been brought up to about that of a 3-inch alternative air spark gap. Much, however, depends upon the size of tube exhausted and upon its temperature.

A fluorescent screen can also be used to determine the presence and amount of X radiation. It is prudent to carry the exhaustion a little further than is necessary to give the best results while on the pump, because the vacuum is liable to be slightly impaired during the process of sealing.

Good makers of tubes are Müller of Hamburg and Hirschmann of Berlin; the gold medal of the Röntgen Society was awarded to the former, and I have had some of the latter for more than two years in fairly constant use. Cox, of 10, Cursitor Street, or Miller, of 93, Hatton Garden, can supply these tubes.

A large tube has the advantage of containing a greater residual store of air, which can be drawn on when desired by slightly warming the tube. With a small tube, the vacuum increases so rapidly with use that it soon becomes difficult, on account of the resistance, to pass the discharge through it. To diminish or to counteract this rise in the vacuum and resistance several devices have been adopted. One is to back the platinum antikathode with a solid disc of aluminium; this prevents the platinum from rising too much in temperature, for it is mainly the overheating of the platinum which leads to the rise in the vacuum.\* By another arrangement the platinum is kept cool by a water jacket, but the best method is to have an arrangement whereby the vacuum can be lowered by the admission of gas. Chabaud and Hirschmann make such tubes. The Chabaud tube is provided with a capillary tube of platinum. The open end of this tube communicates with

\* The rise in the vacuum may also be occasioned by the escape of electrons through the tube walls.

the interior of the X-ray tube, while the closed end is free and projects. If the platinum be brought to a red heat by warming the free end with a spirit lamp it becomes permeable to hydrogen, which passes through it, and so enters the X-ray tube and lowers the vacuum. If it be desired the vacuum can also, but less effectively,

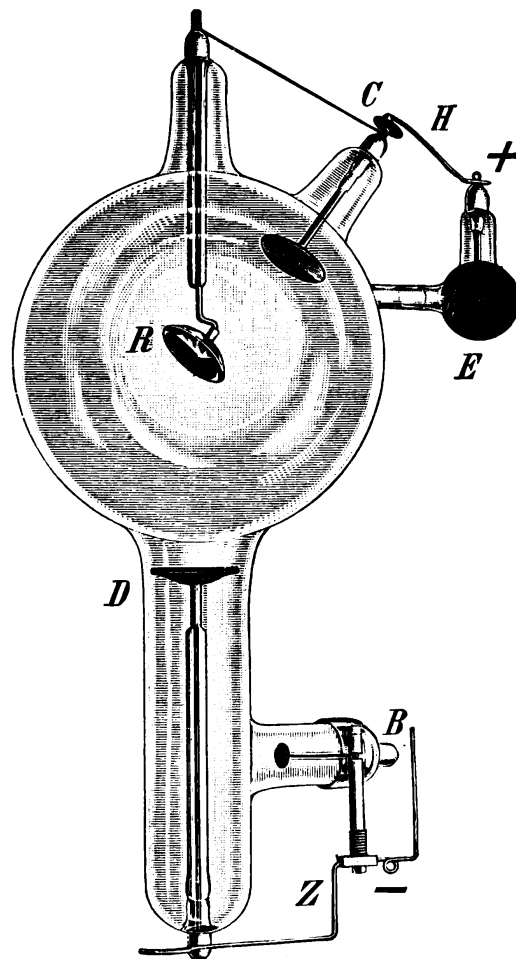

FIG. 154.—HIRSCHMANN'S TUBE, WITH REGULATING ARRANGEMENT.

be raised. At one end of Hirschmann's tube (Fig. 154) is an arrangement for admitting air, and at the other end one for withdrawing air; either can be thrown into action by causing the electrical current which is actuating the tube to enter or leave it by the particular end arrangement.

The tube should be held in a tube-holder (Fig. 155), and the electrodes connected with the secondary terminals of the induction coil by fine copper wire. A hot wire

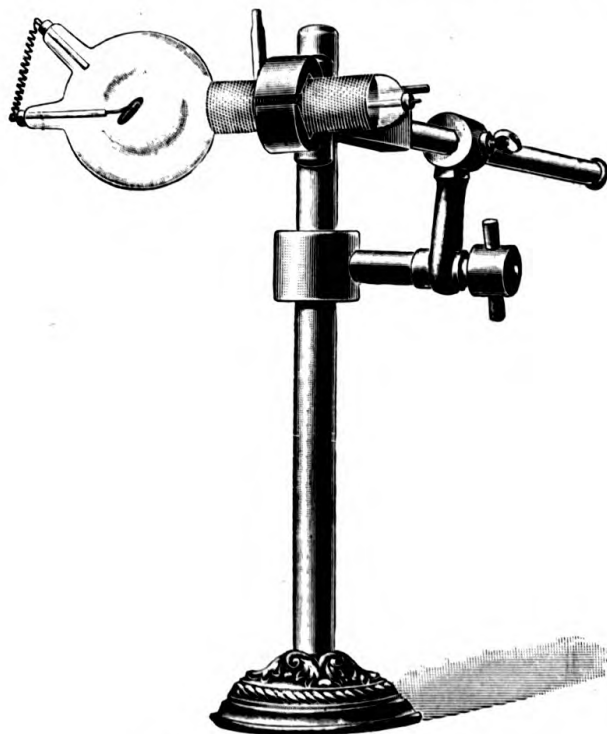

FIG. 155.—TUBE-HOLDER.

milliampère meter (p. 91) and a valve tube (Fig. 156) can also be put into the circuit. A hard tube (one with a high vacuum and high resistance) allows about 1 to 2 milliampères to pass, while a soft tube will allow up to about 6 milliampères to pass. The object of the valve

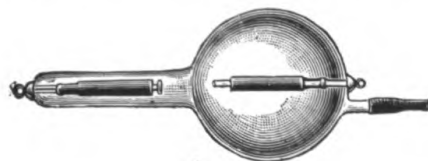

FIG. 156.—VALVE TUBE.

tube is to render the current through the X-ray tube truly unidirectional, so as to prevent, when a coil is used, the deposit of pulverized platinum upon the glass wall.



This deposit is caused by currents set up upon making the primary circuit passing in the wrong direction through the X-ray tube, and the action of the valve tube is to suppress these reverse currents. These injurious currents can also be prevented by raising the self-induction of the coil. Coils provided with an arrangement for this purpose can now be obtained from Schall (Fig. 157). The platinum anode of the tube must be attached to the positive terminal of the coil, and the concave cathode of the tube to the negative terminal of the coil. If the

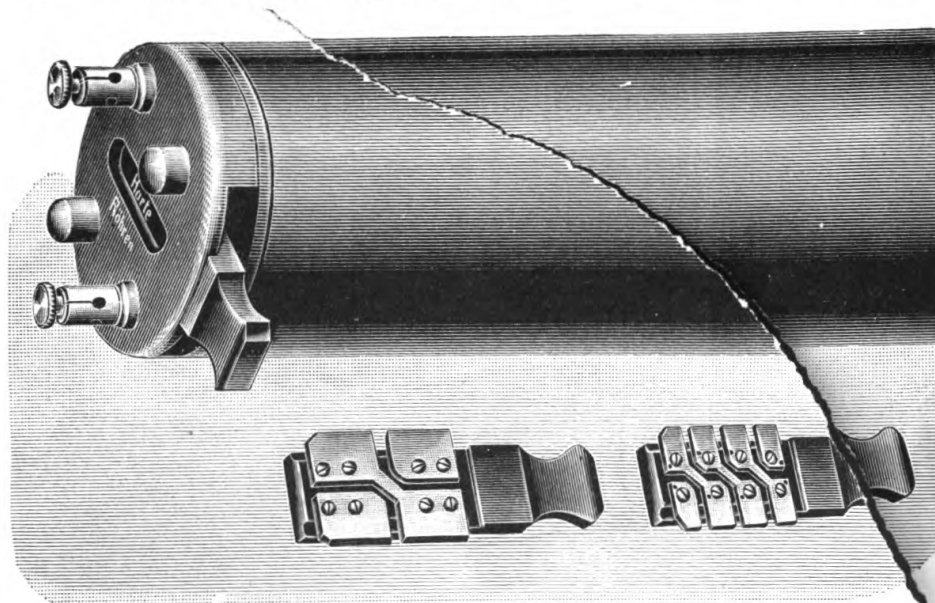

FIG. 157.—COIL WITH ADJUSTABLE SELF-INDUCTION.

character of the terminals of the coil be not known, they can be ascertained when the tube is first tried, and then the connection can be rectified or the commutator reversed. Stout copper wires should be used to connect the battery to the coil, an adjustable resistance and a fuse being also, if possible, placed in the circuit. The movable electrodes of the coil should now be approached to within about 1 inch of each other, and the coil turned on. If the tube does not become at all illuminated, the electrodes of the coil may slowly be separated until they are about 6 or 8 inches apart ; if the tube still refuses to

conduct the current, gas should be admitted by the regulating arrangement, or else it should be carefully, but somewhat boldly, warmed by a spirit-lamp (Fig. 158); the



FIG. 158.—SPIRIT-LAMP ON INSULATING HANDLE.

flame of the lamp should be kept constantly moving over the surface of the tube, and never allowed to remain on one spot. Warming the tube brings down its resistance by setting free the molecules of its residual atmosphere,

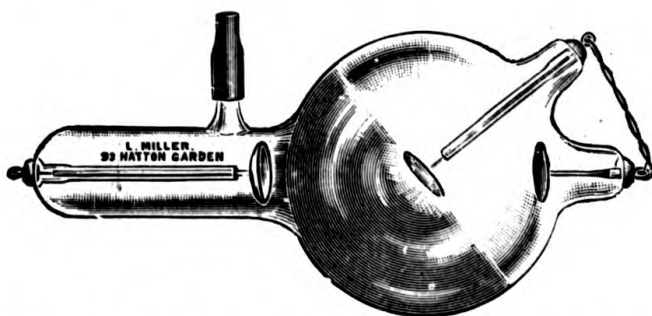

FIG. 159.—X-RAY TUBE PROPERLY EXCITED.

which have become condensed on the sides of the tube, and perhaps also by thoroughly diselectrifying the exterior of the tube. The current should be turned off during the process of warming. When the tube is sufficiently hot,

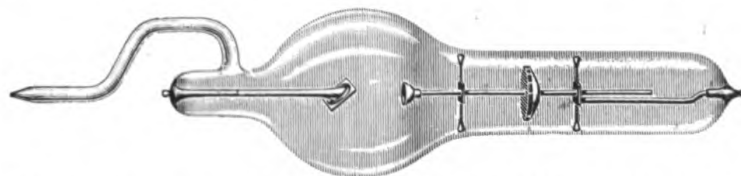

FIG. 160.—DAWSON TURNER TUBE WITH ADJUSTABLE KATHODE.

the discharge will be found to pass through it, and if the connections are right, the part of the tube that faces the free surface of the anode will be bathed with a greenish-

yellow light, somewhat sharply limited by the plane of the anode (Fig. 159); if the tube is wrongly connected, this hemisphere of green phosphorescence will be replaced by small irregular patches of phosphorescence.

The connections having been, if necessary, rectified, the field in which the X rays are present may be explored by a fluorescent screen. Fig. 160 represents a tube designed by the author in which the kathode can be moved towards away or from the anode by means of an external magnet; the resistance of the tube can thus be varied; the resistance diminishes when they are further apart. Mr. Campbell Swinton has also designed such tubes.

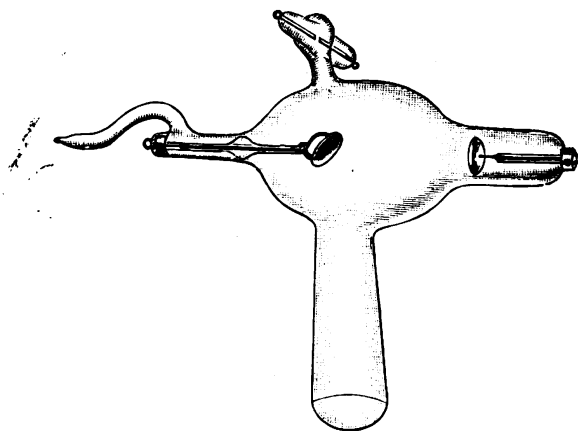

FIG. 160A.—THERAPEUTIC TUBE.

Convenient tubes for therapeutic work and for introduction into cavities (vagina, rectum, etc.) are now made by Cossor (Fig. 160A). The body of the tube is made of thick lead glass, which is opaque to the X rays, and there is a prolongation fitted with a window of a glass through which the rays can pass. With such a tube, no lead screen is necessary for protecting the patient, and the risk of operator's dermatitis is diminished. Dean supplies lead-glass screens or covers fitted with such prolongations or nozzles (London Hospital X-ray shield). The shield can be attached to any ordinary tube, and is easily sterilizable.

## CHAPTER II

### RÖNTGEN X RAYS—*continued*

WE have at our disposal three simple means of detecting the presence of the X rays :

1. X rays will discharge a body charged with electricity.
2. They will cause platino-cyanide of barium and certain other salts to glow with a visible light (fluorescence).
3. They will affect a sensitive photographic plate.

If a piece of glass be rubbed with a silk handkerchief (see Part I., Chapter I.) it will become charged with positive electricity, and will be found to have acquired the property of attracting small pieces of paper or pith balls ; if, however, it be held for an instant near the working focus tube (on the side of the tube which is phosphorescing), it will immediately lose its electrification, and will be incapable of raising the pieces of paper. The same experiment can be tried with a piece of sealing-wax rubbed with flannel. A better method of demonstrating this effect is to make use of an electroscope.

Charge an electroscope and place it about a yard away from the tube ; the latter should be turned so that its phosphorescing side faces the electroscope. Then start the induction coil and observe how rapidly the leaves of the electroscope collapse. Stop the coil, and repeat the experiment with the electroscope at varying distances from the tube ; measure the time that it takes for the leaves to collapse, and it will be found that the nearer the electroscope is to the tube the more quickly will its leaves collapse, and *vice versa*. The intensity of the X radiation roughly varies inversely with the square of the distance ; at double the distance they will only be one-quarter as powerful.

The reason why charged bodies are discharged by X rays is probably because the rays make the surrounding air a conductor by ionizing it ; they destroy *pro tem.* the insulating properties of the air, and thus the electricity leaks away from the charged body. Their action is somewhat akin to that of a flame (*Nature*, March, 1897, Lord Kelvin). They do not, according to my experiments, destroy the insulating properties of paraffin or ebonite, or of solid insulators, nor that of the skin. The resistance of the skin to a constant electrical current remains the same.

More recently, Professor Minchin, in the *Electrician*, April 9, 1897, has described some experiments which tend to show that at any rate in certain special conditions the resistance of still air is not lowered to a conducting value by the passage of X rays. Any conductivity impressed on air seems, then, to be *sui generis*, and of a special kind not strictly conformable to Ohm's law.

The second method of ascertaining the presence of X rays is to make use of fluorescence.

Various salts will light up with a visible glow when exposed to the X radiation. Of these salts, the platino-cyanides of barium and of potassium and tungstate of calcium are about the best, and rank in the order in which they are written above.

A piece of cardboard or fabric coated with one of these materials constitutes a fluorescent screen.

A rough screen can easily be made by gumming one side of a piece of cardboard and by sifting through a piece of muslin on to the wet surface one of these substances in the crystalline condition. It is, however, difficult to get it evenly enough laid on to obtain an equally illuminated surface. Good screens can be bought from the philosophical instrument makers, but are expensive, because the platino-cyanide salts are dear. The screens deteriorate through use, but can be renewed by recrystallizing the salts. The tungstate screens are much cheaper, but do not illuminate so brightly. The double fluoride of ammonium and uranium can also be made use of ; it is

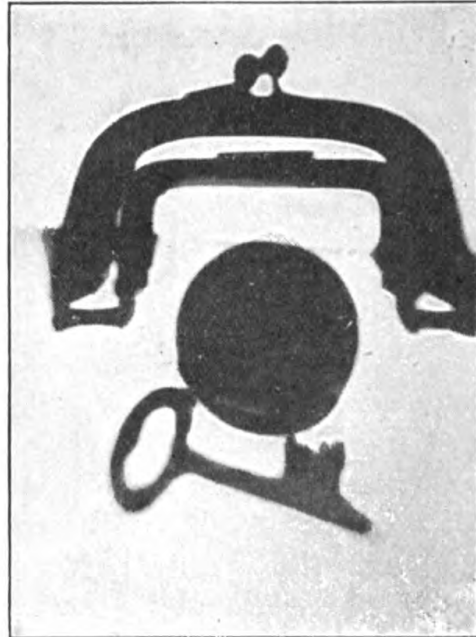

FIG. 161.—LEATHERN PURSE CONTAINING COINS AND A KEY.  
(Photographed in January, 1896. Old form of Crookes tube).

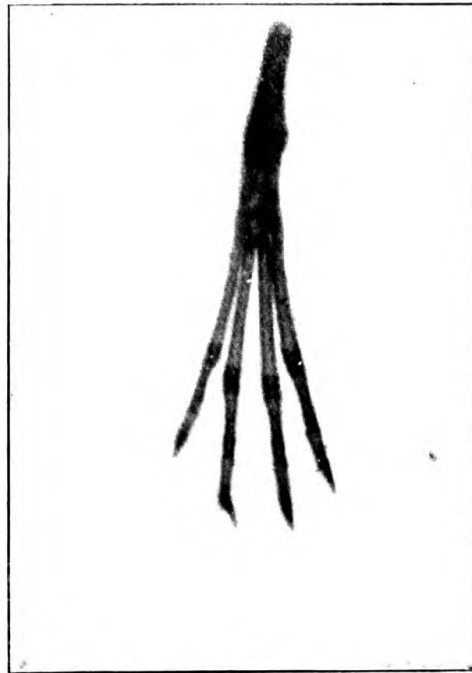

FIG. 162.—RABBIT'S PAW.

cheaper than the platino-cyanides, but is not so efficient.

If the screen be not opaque to ordinary light, it should be made so by covering the reverse side of it with black paper.

To use the screen, the room should be quite dark, and for this reason screen work is best done at night, when the eye also is more sensitive. In some cases it is advantageous to enclose the tube itself in a box, or to cover it with black paper or velvet in order to shield off the stray light it emits.

If the screen be now approached to a working tube, the coated side of it will be observed to glow with a visible light, and the nearer the screen is to the tube, the more brightly will it be illuminated. If the hand be placed between the tube and the screen, the bones will be seen as dark shadows, any metallic object, such as a ring, as a still darker shadow, while the skin will be very faintly outlined. The nearer the hand is to the screen, the smaller and more sharply defined will be the shadows; and these effects will be intensified if the hand and screen be removed to a greater distance from the tube, although the general illumination will be less. The intensity of the shadows thrown may be varied by warming the tube, and it will be seen that if the tube be sufficiently warmed the vacuum can as a rule be so diminished that the rays emitted lose their penetrative power, and throw a dark shadow of the skin. A tube with an adjustable vacuum is very convenient for this purpose. In this way the character of the radiations can be gauged almost to a nicety, and the tube maintained in its best working condition. A needle or other foreign metallic body in the extremities can thus be pretty easily located, especially in the thinner parts and if the foreign body be of fair size.

In all cases the limbs should also be turned so as to throw the rays through from the opposite side, marks being made on the skin at the point where the shadows of the foreign body fall.

In estimating the depth of a foreign body, it should be



FIG. 163.—HAND SHOWING NEEDLE.



FIG. 164.—DISLOCATION OF TERMINAL PHALANX OF THUMB.



remembered that the nearer it is to the screen the smaller will be its shadow.

The importance of being able to localize the exact depth at which a foreign body may lie in the human body is very great. A bullet in the chest or abdomen may be taken as an example ; few surgeons would be willing to undertake an operation for its removal unless they had a very good idea of the depth at which the bullet was embedded. Thus it might be near the front of the chest or near the back, and its removal might be either a simple and easy opera-



FIG. 165.—INJECTED BLOODVESSELS OF KIDNEY.

tion or a very difficult one. To take a simpler case, such as a needle in the hand, it has occurred over and over again to the author that after he has taken an X-ray photograph of such a needle the surgeon has been unable to find it, and the patient has had to be subjected to a second and even to a third operation, with all their discomforts, before a successful result ensued. Many endeavours have accordingly been made by X-ray operators to devise a means of more exactly localizing the position, and particularly the depth, of a foreign body.

Dr. M. Davidson takes two photographs on to one plate,

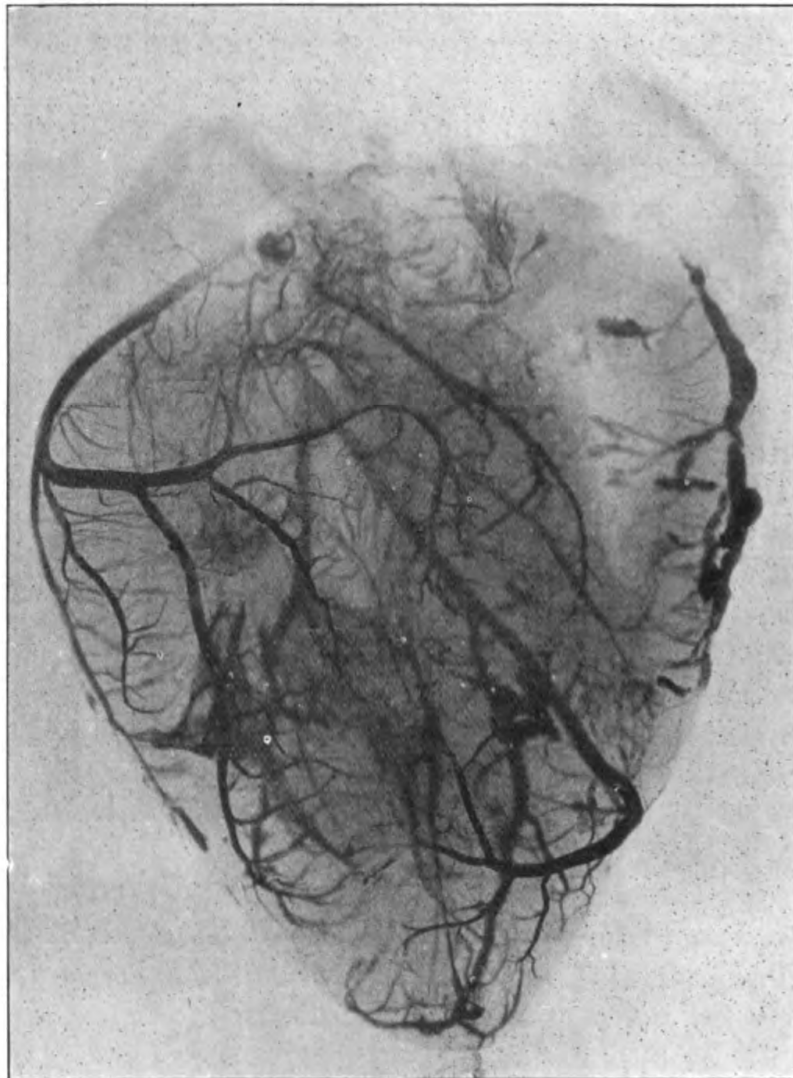

FIG. 166.—INJECTED BLOODVESSELS OF HEART.

and by reproducing mechanically by means of silk threads the course of the rays, he is enabled to exactly localize in the three dimensions of space the position of the foreign body (*British Medical Journal*, January 1, 1898). This is undoubtedly the best method, and it has proved to be of particular value in eye cases. Curry and Paxton are the makers of the apparatus. There are, however, two objections to this method: the one is that it is lengthy and the apparatus expensive, and the other is that by taking the two photographs on to one plate one must weaken, and in some cases even obliterate, the successive shadows. Dr. M. Davidson has now removed this objection, and has further improved his apparatus.

To avoid these difficulties, the author devised, in 1898, with Mr. S. Bidwell's help, a much shorter and simpler method of attaining the same result.

His apparatus consists of a strong horizontal cross-bar, on which is a scale; on this cross-bar a tube-holder slides, and the exact position of the tube-holder can be ascertained by reading the scale through the central glass window of the tube-holder. To give greater accuracy, a fine line is drawn upon the glass.

Beneath the cross-bar a recess is cut in the board that forms the base of the apparatus to contain the negative-holder. The negative-holder is made to slide in and out of the recess, and to occupy during successive exposures exactly the same position.

In order that it may be withdrawn without disturbing the position of the patient, a framework of thin iron plate is placed over it, and in the centre of this a hole 12 by 10 inches in diameter is cut, and over this hole a stout piece of webbing or canvas is stretched. The whole weight of the patient may now rest upon the canvas without pressing upon the negative-holder beneath.

The method of procedure is now as follows:

The patient having been placed in position with the foreign body lying in the plane of the tube (the vertical plane in which the foreign body lies must be previously

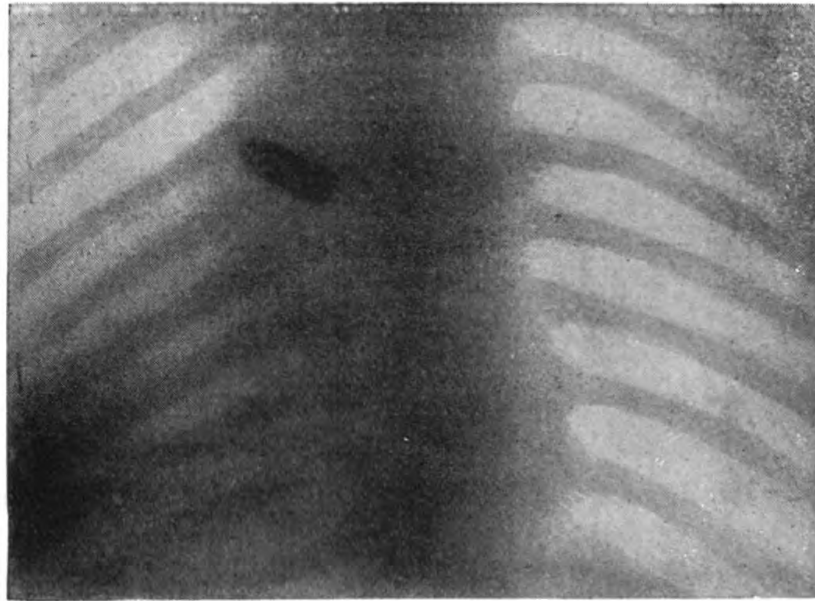

FIG. 167.—THE DUNFERMLINE SHOOTING CASE: CONICAL BULLET  
BETWEEN STERNUM AND VERTEBRÆ.

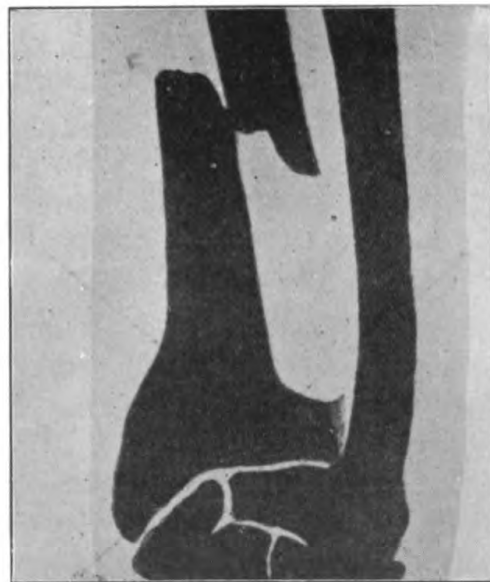

FIG. 168.—BROKEN RADIUS.

(An old injury to wrist, photographed through the splints, and showing faulty position of fragments.)

ascertained by using the fluorescent screen), a photograph is taken with the tube placed a certain distance, say 3 cms., to one side of the vertical through the foreign body.

The negative-holder is now withdrawn and a fresh one put in.

The tube is now displaced laterally through, say, 6 cms., and another photograph is taken. When these plates have been developed the exact depth of the foreign body in the tissues can be at once calculated by employing the following formula :

$$x = \frac{a \times c}{b + c};$$

where  $x$  = the depth of the foreign body measured from the plate.

$a$  = the distance of the antikathode of the tube from the plate.

$b$  = the lateral displacement of the tube.

$c$  = the distance between the two shadows of the foreign body on the negative.

A diagram of the measurements is the following :

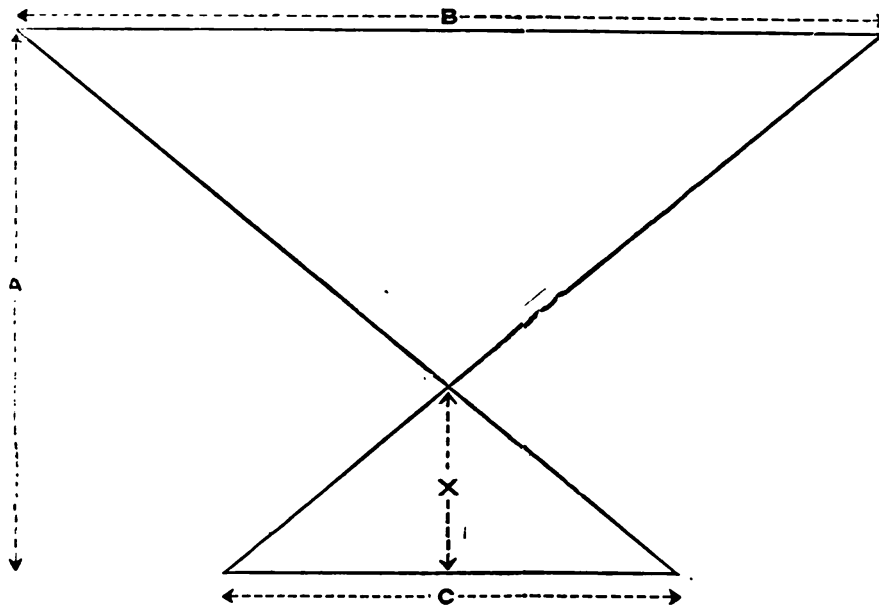

FIG. 169.—LOCALIZATION DIAGRAM.

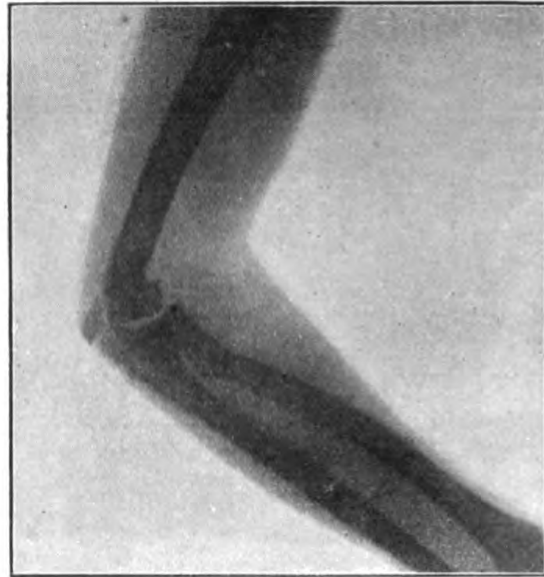

FIG. 170.—ELBOW OF BOY OF 15, SHOWING UNUNITED EPIPHYSIS.

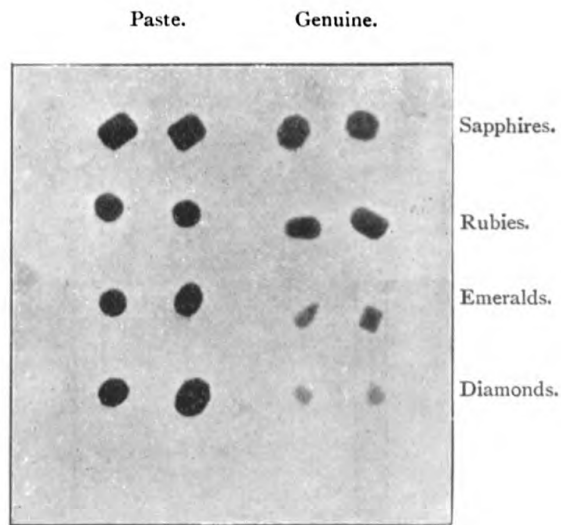

FIG. 171.—PRECIOUS STONES AND THEIR IMITATIONS.

This apparatus was manufactured by Baird, according to the instructions of the author, for the Royal Infirmary, where it has been in operation since 1898.

The importance to practical surgeons of being able to exactly localize the position of such an object as a bullet cannot be overestimated. Fig. 171A is that of a suitable couch.

The stereoscopic method also gives much help in local-

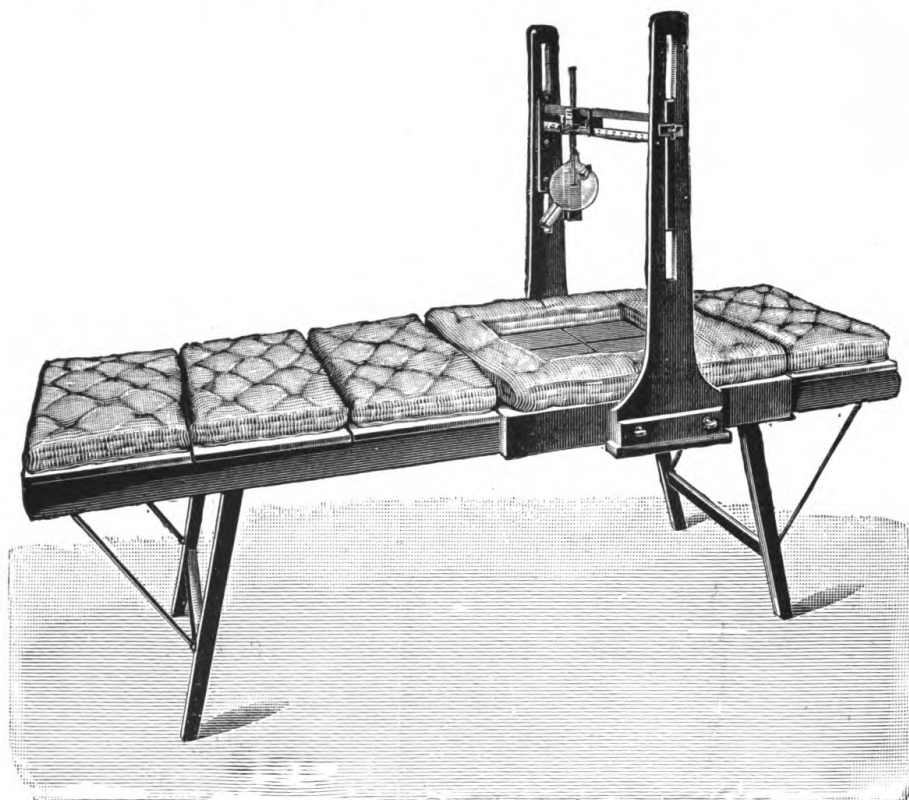

FIG. 171A.—LOCALIZATION COUCH.

ization ; two negatives are taken by the above method and then examined in a Wheatstone stereoscope. If the organs of the body with their bloodvessels injected be photographed and examined by this method the effects are very beautiful, particularly in the case of the brain, heart, and kidneys (Figs. 165, 166). Dr. Davidson has taken a further stage in perfecting a stereoscopic fluoroscope. By this instrument objects can be seen in relief



FIG. 172.—NORMAL ADULT FOOT.



FIG. 173.—FOOT IN SHOOTING-BOOT.



on the fluorescent screen; two communicating X-ray tubes, or a single tube provided with a pair of kathodes and anodes, must be used, so that the vacuum may be the same in each tube. By means of a commutator, each tube is alternately illuminated, and a stroboscopic screen worked by the commutator permits each eye to observe only one of the two perspectives. The relative position of a foreign body in a limb can be thus at once seen. The apparatus is expensive (see *British Medical Journal*, December 3, 1898).

The rays traverse the thorax more easily than the neck or abdomen; it is difficult to obtain sharp shadows



FIG. 174.—OPAQUE ENVELOPER.

through the abdomen, probably because of the scattering the rays undergo in penetrating so much soft structure.

To examine the thorax, the patient should be stripped, or should only retain a light garment without metallic buttons; the tube should be working at its best, and the room should be absolutely dark. Place the patient first with his sternum towards the tube, at about 4 inches from it, and hold the screen, which should be of large size, against his back; the vertebral column and ribs and scapulæ should now be plainly seen, and the heart faintly outlined. The upper border of the diaphragm, particularly on the right side, is quite evident, and can be seen to rise and fall with respiration. Now turn the patient round



FIG. 175.—CHINESE LADY'S FOOT, SHOWING DISEASE OF THE TIBIA.



FIG. 176.—SEVEN-TOED FOOT OF BOY OF 16, SHOWING UNUNITED EPIPHYSIS.

and place the screen against his sternum; the heart will now be more definitely outlined. The beating of the heart can usually be fairly well seen, particularly if the finger be placed at the same time on the pulse.

An atheromatous aorta throws a distinct shadow, and in a case of Dr. Elder's, of Leith, we could plainly see an aneurismal dilatation of the aorta, the existence of which had been previously suspected. This dilatation could be observed to beat. Amongst other diseases of this region which can be recognised by the aid of the screen must be mentioned *pleurisy with effusion*. Further, the nature of the exudation can be surmised; a serous effusion throws a lighter shadow than a purulent one; when pus is present the outlines of the ribs are obliterated by the dense and opaque shadow. Dr. Lawson remarks that when air is present the upper margin of the fluid is sharper and more horizontal. The upper outline of the diaphragm is also masked on the affected side. When the upper margin of the shadow does not alter at all in position with movements of the patient, some other condition must be suspected. In *emphysema* the thorax is abnormally transparent, the diaphragm is depressed, the intercostal spaces are widened, there may be cardiac enlargement and displacement, and the angle of the clavicles is raised.

In *early phthisis* the screen examination will show that the affected apex does not become so transparent on deep inspiration as the healthy one: it does not illuminate so well; further, the excursion of the diaphragm on the affected side is diminished. (Williams claims that the lessened movement of the diaphragm may precede any other physical sign.) Attention should also be paid to the smallness of the heart.

*Phthisical consolidations* and *cavities* can easily be made out by a practised eye. The former are more opaque than the normal lung, and, in a case that has not gone far, give rise to a peculiar marbling or mottled appearance. Cavities appear as lighter areas surrounded by darker borders, but if the cavities contain pus they throw



FIG. 177.—NORMAL ANKLE-JOINT.

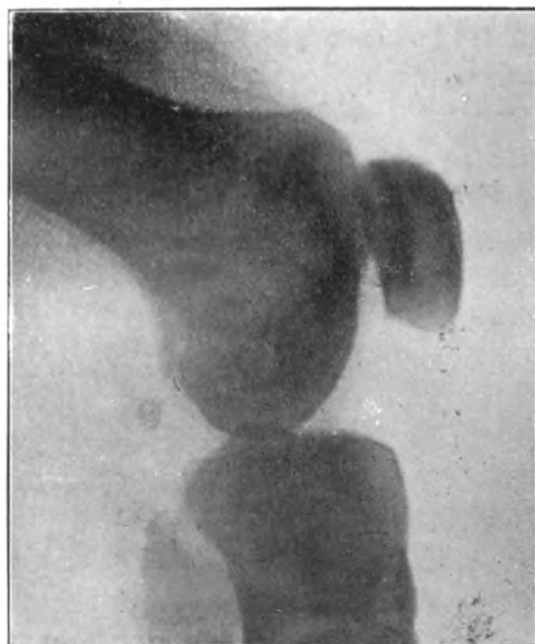

FIG. 178.—SEMIFLEXED KNEE OF ADULT, SHOWING SESAMOID BONE IN GASTROCNEMIUS.

a dense shadow. Dr. Hugh Walsham has shown that the presence of tubercle can be recognised by the Röntgen rays before abnormal physical signs appear, and that in suspected early cases, where no Röntgen shadow could be seen, there was no subsequent evidence of disease.

Intrathoracic tumours, advanced fibroid conditions of the lung, gangrene of the lung, and displacements of the heart, are also open to observation, and these observations should be used in conjunction with the ordinary clinical signs. The fact that a tumour can be observed at every point of its visible margin to pulsate is unquestionably a valuable aid in the diagnosis of *aneurism*, and screen work is of more value than photography in such cases.

Foreign bodies, placed in the middle line between the vertebral column and the sternum, will often escape observation, owing to their shadows falling into the shadows of the vertebral column and sternum, unless the rays be passed obliquely through the body. In the Dunfermline shooting case, where a bullet entered at about the level of the fourth rib, the photographs which were taken in Glasgow were misleading, and led the operator to suppose that the bullet was in the liver; later on the patient was examined by me with a screen, and, though no trace of the bullet, either in the liver or thorax, could at first be made out, yet on passing the rays obliquely, so as to throw the shadow of any object in the mid-line of the body out of the field of the shadows of the sternum and vertebral column, the shadow of the conical bullet could be most distinctly seen (Fig. 167).

By means of the screen, many experiments can be performed much more expeditiously than by using a photographic plate; thus, the transparency of various objects can be at once estimated by placing them between the tube and the screen. If a piece of tracing-paper or ground glass be placed against the screen, the outline of the heart, etc., or position of any foreign body, can be marked



FIG. 179.—EXTENDED KNEE, SHOWING SHOT.

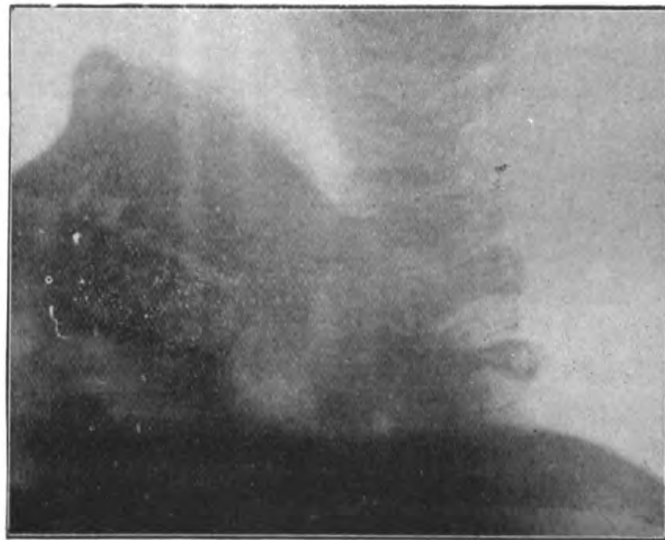

FIG. 180.—PHOTOGRAPH OF NECK, SHOWING JAW, TEETH, AND VERTEBRÆ.

out. All the heavy metals are opaque, but the lighter ones, such as aluminium, sodium, and lithium, are transparent; wood, paper, books, and organic substances are more or less transparent. Röntgen found that the rays would traverse packs of cards and very thick volumes. Little can be added to the general law he laid down, that the opacity varies directly with the density; we should now say with the atomic weight.

Benoist has invented an instrument, called the radio-chromomètre, for measuring the *penetrating power* of the X rays. It consists of a number of discs of aluminium of increasing thickness arranged around a disc of silver; it is now easy with the fluorescent screen to determine which of the aluminium discs, using a particular tube, has the same transparency as the silver disc. Benoist laid down certain laws, of which the following are the more important:

1. The transparency of a body to a given quality of X rays is independent of the physical state of that body, provided the mass is the same.

2. The transparency of a body is independent of the grouping of its atoms or molecules and of the state of liberty or of combination of its atoms. The following table, taken from the 'Encyclopædia Medica,' vol. xiii., p. 498, is one of the order of relative transparency:

**Quite Opaque.**—Platinum, mercury, bismuth, lead.

**Opaque.**—Copper, iron, zinc.

**Semi-transparent.**—Flint glass, aluminium, quartz, crown glass, calculi of lime oxalate, calculi of phosphates, bone, calculi of uric acid.

**Transparent.**—Biliary calculi, cutaneous tissue, tendons, arteries, muscles, blood, veins, nerves, brain, pus, urine, milk, water, human fat, wood, etc.

As it is frequently desirable to screen injured limbs without disturbing the dressings, the relative opacity of certain common antiseptics is worthy of note. Castex ('Électricité Médicale,' p. 534), following Benoist's method,

has arranged the antiseptics in the following order, commencing with the most opaque :

Corrosive sublimate	-	1.18	Euophene	-	-	3.17
Iodoform	-	-	Pot. permanganate	-	-	8.3
Iodol	-	-	Boracic acid	-	-	50.3
Traumatol	-	-	Salol	-	-	64.5
Dermatol	-	-	Phenol	-	-	67.0
Aristol	-	-	Naphthol	-	-	69.2

Naphthol is therefore some sixty times as transparent as corrosive sublimate.

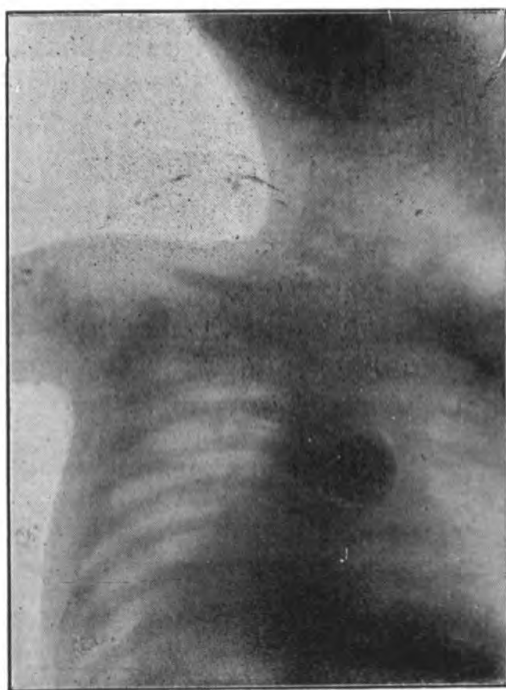

FIG. 181.—HALFPENNY IN THE THORAX.

Thus, metallic objects in a wooden box or a leathern purse can be immediately made out (Fig. 161); the bones of the forearm can be distinguished almost as well through the sleeve of the coat as when the arm is bare. Diamonds and precious stones are, as a rule, far more transparent than their glass imitations, so that the latter can be immediately detected. Fig. 171 is a photograph taken by



the author of a pair of diamonds, of emeralds, of rubies, and of sapphires, with their paste imitations.

The *quantity* of rays emitted can be estimated by Holznecht's instrument. A salt is used which turns a bluish-green on exposure to the rays. The colour produced depends upon the quantity of rays absorbed. If a disc of the salt be placed during an exposure close to the patient, the dose he is receiving can be estimated by the change in colour which is compared with a standard colour. The burning effect of the rays is probably associated with both the quantity and penetrating power of the rays.

Lastly, X rays will affect photographic plates.

The plate need not, however, be exposed, for the rays will pass quite easily through the wooden shutter of the dark slide ; nor must a camera and lens be used, because the rays, as Röntgen pointed out, cannot be refracted, and the only effect of the lens would be to throw a dark shadow, in consequence of its opacity. A dry plate is placed, using a red light, in a dark slide or opaque paper envelope (the latter is best ; Fig. 174), and is then brought out and placed underneath the tube, and at a distance of about 6 to 14 inches from it. There appears to be no advantage in using a very rapid plate ; a medium plate is as sensitive to X rays as a rapid one, but it is important that the plates should be fresh. A number of experiments were made by me to determine this point, and the result communicated to the *Electrician* for February, 1897. Many attempts have since been made to prepare a negative which should be more sensitive to X rays, but without much success. From a large experience in the electrical department of the Edinburgh Royal Infirmary and elsewhere of Lumière's X-ray plates, of kathodal plates, and of others, I cannot say that I have found these, on the whole, superior to other plates that have not undergone any special preparation. Any good brand of plates of medium rapidity and with thick films will do. Celluloid films will only yield good results when fresh. The plate should be laid on a flat

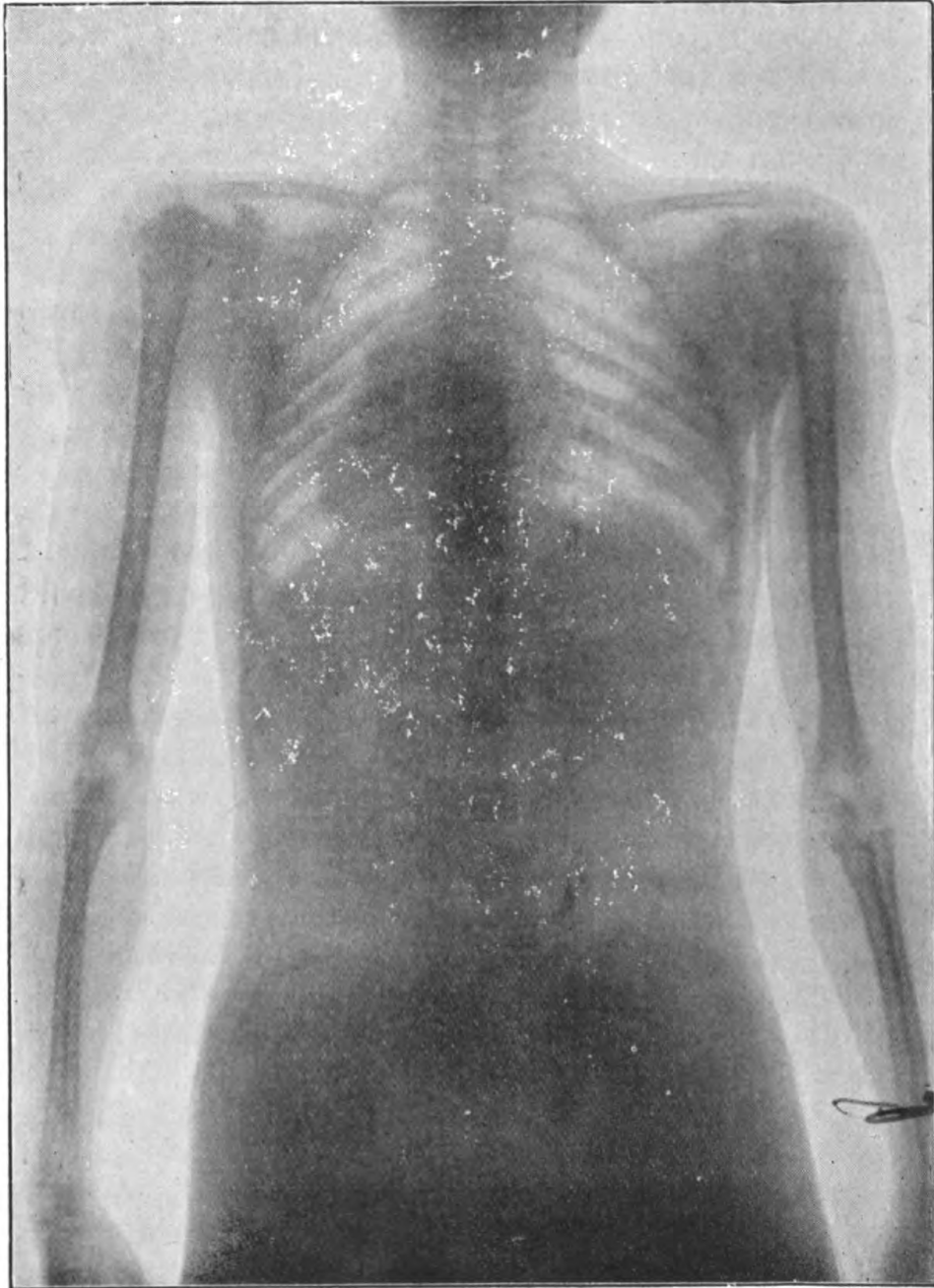

FIG. 182.—THE TRUNK AND UPPER EXTREMITIES, BY  
WILSON NOBLE.

sheet of lead let into a strong board which has its edges bevelled off. The purpose of the lead is to give sharper shadows by diminishing the secondary X rays, which might fog the plate. (All forms of matter, even the air, become the source of secondary and tertiary X radiation when traversed by primary X rays; this is the chief difficulty in obtaining sharp shadows in the radiography of the abdomen, for the soft tissues become an abundant source of secondary X rays, which, travelling in all directions, diminish or obliterate the shadows thrown by the direct or primary X rays from the tube.) The object to be photographed is now placed upon the envelope of the plate, and the tube is turned so that its active hemisphere—that which exhibits the uniform greenish-yellow phosphorescence—points downward towards the plate; the platinum mirror should, roughly, be over the middle point of the plate. The tube should be about horizontal, but for every tube there is a particular position in which it should be placed in order to get the maximum number of X rays projected on to an object, and this must be ascertained for each tube by experiment. The sensitive surface of the plate should be uppermost. It is well to ascertain that the tube is working properly before putting the plate into position; this can be determined by means of the screen, or, with practice, by the general appearance of the tube and length of the alternative spark gap. The active side of the tube should have a thick moss-green colour, which should apparently fill the interior also of the active hemisphere. The coil should now be turned off, the plate and object to be photographed placed quickly in position, and the coil again turned on. The length of the exposure, using a particular tube and coil, depends upon the thickness and density of the object to be photographed and upon the distance between the tube and the plate. To speak more accurately, it varies approximately with the square of this distance; thus, if the distance between the tube and plate be doubled, the exposure, other

things being equal, would require to be four times as long. After exposure the plate is developed in the ordinary way. Hydroquinone is preferred to pyrogallic acid, because it produces harder negatives. On the Continent it is customary to develop very slowly ; thus the developer may be diluted some twenty-five times, and the plate may be kept in it for an hour or more. The satisfactory development of radiographs of the hip-joint and abdomen and of obscure bone diseases requires a great deal of care and considerable experience.

With a 10-inch spark coil and a good focus tube, the exposure, roughly speaking, for the hand at a distance of 12 inches might be from five to twenty seconds.

If the plate be brought close to the tube only a second would be required, but then the definition would not be nearly as good, and the outlying bones would throw exaggerated and distorted shadows.

The further the plate from the tube, the sharper and the more uniform will be the resulting negative. For the foot, an exposure of forty seconds may be given. Fig. 173 is the photograph of a foot in a strong shooting-boot ; the nails and lace-rings, being metallic, are very evident, but the sewing of the soles can also be seen. The time of exposure was two minutes, with a 6-inch coil.

Fig. 175 is the photograph of the foot of a Chinese lady, the specimen being kindly lent to the author by Professor Sir William Turner. The os calcis is at right angles to the metatarsals.

To photograph the knee, the patient should be seated, and should rest his leg upon a chair, or should recline upon the X-ray localization couch (Fig. 171A) ; the tube should be placed laterally at the same level as the knee, but some distance away from it. By means of the screen the shadows thrown by the knee should now be examined, in order that any distortion may be rectified by slightly altering the position of the tube either towards the foot or towards the trunk, and in order also to see that the resulting picture would not be too large for the

photographic plate. If it be too large, the tube must be moved further away. When these points have been attended to, the plate is placed in position and an exposure of from thirty to seventy-five seconds given. The knee may also be easily photographed when semi-flexed or flexed, and the positions of the patella observed. Lateral photographs are more easily obtained, and are more satisfactory than antero-posterior ones.

The hip-joint, owing to its great depth, is more difficult to photograph satisfactorily; plates placed underneath it are apt to be broken by the patient's weight if the strong flat board to support the plate be not used. To obtain sharper shadows, a diaphragm of lead with an aperture in it may be interposed between the tube and the patient.

A preliminary use of the screen will be of advantage in taking photographs of the thorax or abdomen, especially in cases where foreign bodies have to be localized. An exposure of from two to four minutes should be sufficient.

Of the abdomen, for the reasons mentioned on p. 362, it is much more difficult to get a good negative; prolonging the exposure may be tried, but is not of much service; there is, owing to the secondary radiation, a tendency to a general fogging of the plate, without the formation of defined shadows.

The successful photography of renal and other calculi is a difficult though most important branch of Röntgen ray work. Biliary concretions of cholesterin may be dismissed for the present as being beyond our powers, owing to their great transparency (p. 360). Of renal calculi, the oxalate of lime are the most opaque and therefore the most easily photographed; next come the phosphates and urates. The method adopted in the Edinburgh Royal Infirmary for such cases is as follows: The patient is first of all prepared by having the bowels emptied either by a purgative or enema; the negative, supported upon a stout board, is placed in position at the back of the patient, who is recumbent. The negative should be 12 by 15 inches in size, or larger. A light flannel binder is then fastened firmly round the abdomen, so as to limit as much as

possible the respiratory movements ; finally, the knees are bent upwards into a vertical position. The length of exposure given is two minutes. It is advisable, if the result is negative, to take two or three more photographs with exposures varying from one and a half to three or four minutes. The lead diaphragm will also be of service, but will entail a longer exposure. A hard tube should for these cases be avoided ; the secret of success lies in rightly gauging the length of exposure, for too long an exposure will obliterate the shadow that would first be thrown. It is safer to place the tube in the middle line. In a case of Professor Annandale's of suspected renal calculus, the first and only negative taken showed three calculi quite distinctly in the left kidney (the suspected one), and at the subsequent operation these three were removed ; but the patient sank afterwards, and at the necropsy the right kidney was found to be full of calculi. The tube had in this instance been placed over the left kidney, but had it occupied a central position, probably the calculi in both kidneys would have been revealed. In order to examine such a negative to the best advantage, it should be placed against a window with a northern aspect, and the rest of the window should be darkened. The examiner should now place himself some 6 to 10 feet away.

Mr. W. H. Shenton, of Guy's Hospital, has published in the *Guy's Hospital Reports* an analysis of 200 of such cases, with the following results :

Cases in which the rays and surgeon found calculi, 28.

Cases in which the surgeon found calculi, but the rays did not, 8.

Cases stated not to have calculi by the rays, and operated on with negative results, 11.

Cases in which the rays found calculi and the surgeon did not, 2.

In 39 cases the rays were correct, in 8 they were wrong.

Mr. Shenton places the patient upon his face and the tube underneath, and about 6 inches from the abdomen ; the screen is first used, and then the plate is placed upon

the patient's back and an exposure of a minute or less is given.

Many attempts have been made to shorten the exposure for the thicker parts by using fluorescent materials in conjunction with the negatives. Mr. John Aitken, working with me in February, 1896, found that the sensitive films of negatives were more quickly affected by the visible light of substances fluorescing under the action of X rays than by the X rays alone. Others have also made the same observation (*Nature*, May 21, 1896).

Referring to our own experiments more particularly, we first tried washing the negatives with solutions of the platino-cyanides, but obtained better results by placing a screen, coated with the crystalline material, against the negative during exposure to the rays. It is of importance to have the fluorescent material in close contact with the sensitive film, and it is perhaps better to place the film between the tube and the screen; but glass plates, in consequence of their opacity, are not suitable for this; celluloid films or sensitive paper (Eastman's 'X Ray') may be used.

The order from the tube would be, supposing the hand were going to be photographed: Tube, hand, celluloid film with sensitive surface turned away from the tube, fluorescent material.

If glass plates be used, the sensitive surface must be towards the tube, and the screen placed upon it. Finely powdered calcium tungstate or fluorspar yields quite as good results for this purpose as the platino-cyanides, and the potassium platino-cyanide is superior to the barium salt.

By using this method, the exposures, particularly for the thicker parts, can be much shortened; thus, a good photograph of the thorax can be taken in a few seconds, but the disadvantage is that the shadows are never so sharply defined, and the negative invariably has a granular appearance. The result is that most operators prefer to give a longer exposure, and to get a better photograph.

## CHAPTER III

### FINSEN LIGHT AND RADIUM RADIATIONS

OF the unquestionable value of the X rays and of the Finsen light in the treatment of rodent ulcer and of lupus there can no longer be any doubt. It will be well, then, before comparing their therapeutic effects, to study the nature and production of the ultra-violet or Finsen light.

Dr. Finsen's name has been associated with the red-light treatment of small-pox and the ultra-violet light treatment of skin diseases. It is with the latter that we are now concerned.

#### **Production of the Ultra-Violet Rays.**

They are found naturally in sunlight. They may be artificially produced chiefly in two ways :

- (a) By an electric arc light.
- (b) By an electric spark from a condenser.

Doubtless they are present to a varying extent in other sources of illumination, but are either deficient in quantity or are cut off by some opaque substance, such as by the glass of a Röntgen ray tube. Probably other powerful sources of ultra-violet radiation will be found. I made some experiments with burning magnesium wire, but was disappointed with the result. The sunlight cannot often be made use of in our climate, and there are two disadvantages which attend it : one, that it is also such a powerful source of radiant heat, which must in some way be filtered off ; and, secondly, that much of its



ultra-violet radiation is absorbed in passing through our atmosphere.

(a) The arc light with carbon electrodes gives off blue and violet rays freely and ultra-violet in fair amount ; if provided with iron electrodes, the emission of the ultra-violet is increased, but it labours also under the disadvantage of being a copious source of radiant heat. Means must be taken, then, both in its case and in that of the sun, to remove, by some cooling medium or substance opaque to radiant heat, the excessive heat rays, which would otherwise cauterize the part.

(b) It has long been known that the electric spark produced by the discharge of a condenser was of a brilliant character, and that it had strong actinic qualities, but Dr. Görl of Nuremberg was the first person, so far as I am aware, to make use of it therapeutically (*Münch. Med. Wochenschrift*, No. 19, 1901).

This spark is obtained by connecting a condenser or large Leyden jar to the induction coil used in Röntgen ray work, and causing the discharge of the jar to pass between two electrodes, which preferably are of iron. Acting on a suggestion of Mr. Leslie Miller, I compared the ultra-violet radiation of the condenser spark with that of an arc light with carbon electrodes.

### Recognition of Ultra-Violet Radiation.

We have the following means of recognising the presence of ultra-violet rays :

- (a) They are powerfully actinic.
- (b) They can excite fluorescence.
- (c) They can discharge an electrified body (Hertz), provided the body is negatively electrified.
- (d) They have a special action on the skin of the higher animals, and on the entire tissues of the lower animals and plants—bactericidal effect.
- (e) They can produce nuclei for cloud condensation in moist air (Wilson).

(a) The difficulty of comparing the photographic effects led me to discard such an attempt.

(b) To compare the fluorescent effect I had some quartz lenses and prisms made, and projected by their means the spectrum of the two sources of radiation. One of the chief difficulties that presents itself in dealing with these rays is due to the fact that glass is quite opaque to the extreme ultra-violet. Hence glass lenses and prisms cannot be used, and to produce a spectrum by refraction some more transparent substance, such as rock-salt or quartz, must be made use of.

For various reasons it is difficult to make an accurate comparison by this method ; still, the experiments communicated by me to the Royal Scottish Society of Arts, January 27, 1902, showed a greater lengthening of the spark spectrum by potassium platino-cyanide (and calcium tungstate) than that of the arc light. The barium salt did not visibly fluoresce in the spectrum of the spark, and the calcium salt did not in the spectrum of the arc. I also compared the spectrum of Dr. Bang's lamp (with iron electrodes); this yields a violet and ultra-violet radiation similar to that of the condenser spark, though not so extended, and calcium tungstate fluoresces. As a result of these experiments, I concluded that the condenser spark was richer in ultra-violet rays than the arc light. (The radiation was of shorter wave-length and greater frequency.)

(c) The property of discharging an electrified body is the most easily tried.

The radiation of an arc light will, at ordinary atmospheric pressure, only discharge a negatively electrified body, and the body must have a freshly-cleaned surface of some special material, such as zinc or aluminium.

The condenser spark will, however, discharge either a positively or a negatively charged body, and irrespective of any special material. The discharging is, however, more rapidly produced if the body be charged negatively, and still more rapidly if the body be provided with a zinc

surface, so the difference may be one mainly of degree. Under the latter circumstances (when the body is negatively charged and provided with zinc) the experiments showed that, while the arc light required twelve seconds to discharge the electroscope, the condenser spark, at a similar distance of 5 inches, required only five seconds. We may conclude, then, that the condenser spark is very much richer in those ultra-violet rays which discharge an electrified body than is the arc light.

I gather from these and from the preceding spectrum experiments that the radiation of the condenser spark is of a higher order (more ultra ultra-violet) than that of the arc with carbon electrodes. Dr. Bang's lamp was now tried with the electroscope. Without a surface of zinc to strike it did not affect it, but when the electroscope was provided with a clean zinc surface and was negatively charged, then the lamp discharged it very rapidly (in five seconds through 1 inch of rock-salt).

#### **Transparency and Opacity to Ultra-Violet Rays.**

Dr. Finsen proved that these rays can penetrate bloodless tissues far more easily than those filled with blood. He placed a piece of sensitized paper on one side of a man's ear, letting the blue and violet rays of one of his apparatus for concentration of sunlight fall on the other side of the ear. After five minutes this paper was not affected; on the other hand, the paper was distinctly blackened in twenty seconds if all the blood were pressed out of the ear between two glass plates. In agreement with this is the fact that if you look, using a spectroscope, through an ear filled with blood you will only see a red stripe, but if the ear is made anæmic the spectrum will consist of all the colours. Accordingly, the area of the skin that is to be treated by light rays must be made as anæmic as possible (Dr. V. Bie, *British Medical Journal*, September 30, 1899).

It must be observed that Dr. Bie in these experiments only dealt with blue and violet (not ultra-violet) rays; the glass plates would cut off the ultra-violet.

To produce anæmia a compressor through which the rays can pass must be used, and therefore the question of transparency is of great importance. To test this question a series of experiments were carried out by me, of which the following are of chief interest. (In the following experiments the electrodes of the condenser spark were of iron, and the electroscope was placed 5 inches away and was negatively charged; to test the transparency of an object it was interposed between the source of radiation and the electroscope.)

<i>Object.</i>	<i>Effect on Electroscope.</i>	<i>Deduction as to Transparency.</i>
Mica, $\frac{1}{80}$ inch thick	- Nil	Opaque.
Glass, $\frac{1}{8}$ inch thick	- Nil	Opaque.
Sheet of notepaper	- Nil	Opaque.
Red } Green } Violet }	gelatine films - Nil	Opaque.
Paraffin, $\frac{1}{4}$ inch thick	- Nil	Opaque.
Hand	- Nil	Opaque.
Bone, $\frac{1}{4}$ inch thick	- Nil	Opaque.
Rubber, $\frac{1}{4}$ inch thick	- Nil	Opaque.
Ebonite, $\frac{1}{80}$ inch thick	- Nil	Opaque.

All these bodies, then, were found to be opaque, and the opacity of glass is to be particularly recollected; ultra-violet rays may be present in abundance inside a Röntgen-ray tube, but they will be all stopped by the glass. It is, however, possible that the X rays, in passing through the glass, may, by a species of fluorescence, give rise to new ultra-violet rays, and these might emerge and give rise to some of the phenomena of the X rays; but I am inclined, for other reasons, to doubt this. The succeeding experiments relate to bodies that are more or less transparent to the ultra-violet radiation; the transparency was estimated by the time taken to discharge the electroscope, and the results are based upon an average of a number of experiments. When no body was interposed between the electroscope and the source of radiation it was found that the electroscope was discharged in five

seconds. This number, then, represents the transparency of air. The transparency of other bodies, such as rock-salt, depends very largely upon the polish of their surfaces; their thickness is of less consequence.

<i>Object.</i>	<i>Time in Seconds taken to discharge the Electroscope.</i>
Polished pure rock-salt, 3 inches thick - -	6
Ice, $2\frac{1}{4}$ inches thick - - -	10
Less highly polished pure rock-salt, 1 inch thick	9
Unpolished pure rock-salt, $\frac{9}{8}$ inch thick -	10
Rough and striated pure rock-salt, $\frac{3}{8}$ inch thick -	14
Polished quartz lens, $\frac{3}{8}$ inch thick in middle -	15
Grape-sugar, $\frac{1}{4}$ inch thick - - -	15

No other substance tried was so transparent as the above, except water, and the latter seemed, if pure, to rank with quartz. Its transparency was estimated by enclosing it in a cell with quartz windows, the effect of the quartz windows being first allowed for.

I gather from these experiments that pure polished rock-salt is more transparent to the ultra-violet rays of a condenser spark than either ice or quartz, and that it should therefore be used if possible as the compressing agent. Care must be taken to keep it quite dry (pure rock-salt does not deliquesce), for a film of moisture upon it, owing to the electrical conductivity of brine, makes it quite opaque to the radiation, and also destroys its polish. It may be cleaned by a soft rag moistened with absolute alcohol.

#### **Mode of Employment of Ultra-Violet Rays.**

In the original method employed by Finsen with the arc light (Fig. 183), four telescopic tubes were arranged at an angle of  $45^\circ$  from the horizontal round a large arc lamp which required current at the rate of 60 ampères. The function of these tubes was to concentrate the violet and ultra-violet rays and to remove the heat rays. The rays were concentrated by quartz lenses, between which was a column of running water to absorb the rays of heat.

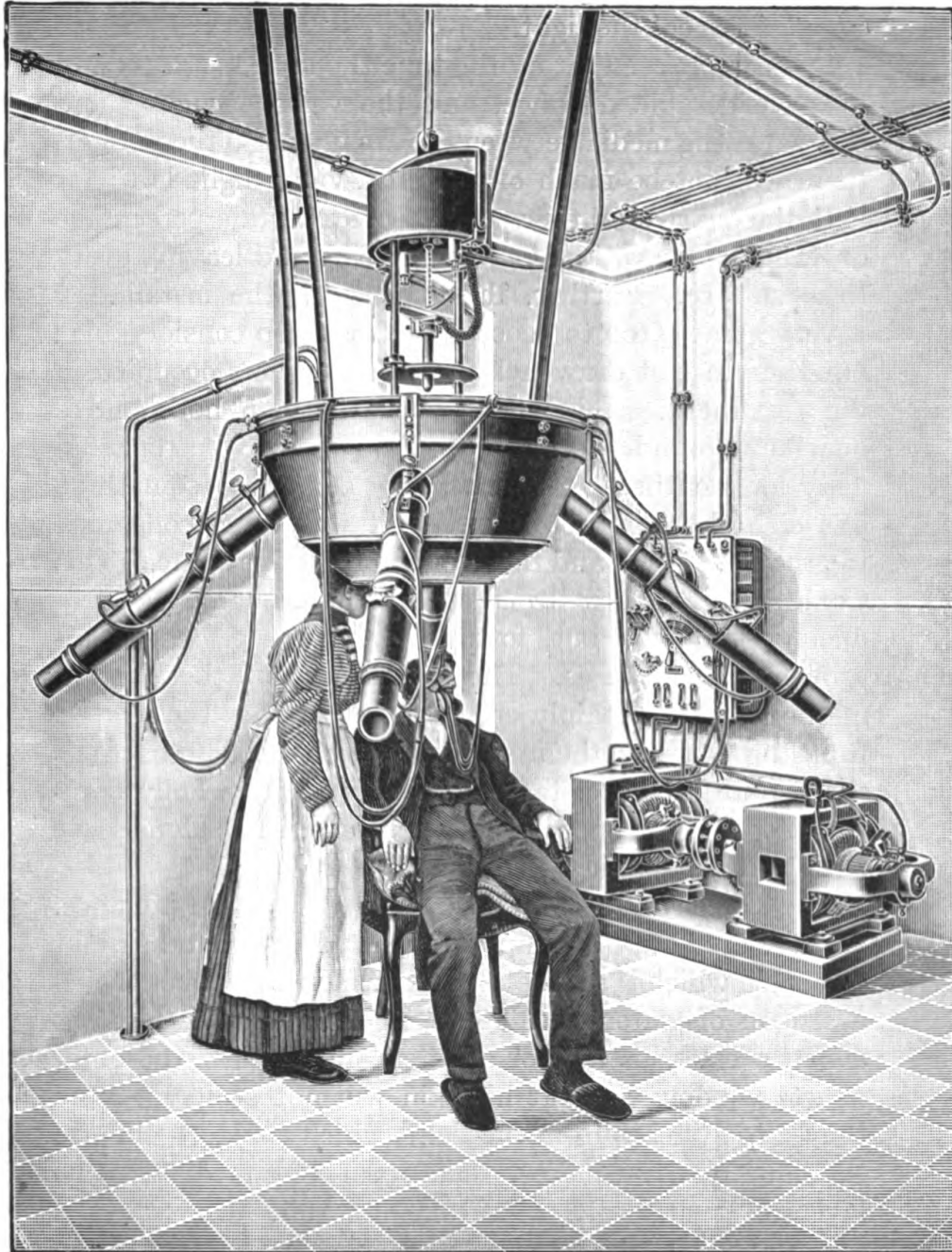

FIG. 183.—FINSEN ARC LIGHT.

In addition, a hollow compressor of quartz, also containing running water, was needed to render the skin anæmic and completely cool the light.

It is easy to see that by the time the light has traversed the considerable distance, and the various cooling and concentrating media between the arc light and the patient, there will not be much of the ultra-violet light left ; for both the quartz and the water absorb a certain percentage of it, and some will be lost on entering and leaving every fresh surface. Further, the expense of the installation is very great (£100 to £200) and its upkeep considerable ; but the greatest drawback of all is the time occupied in the treatment. A lengthy exposure of an hour and a quarter is found necessary, and this has to be repeated daily for months. A large amount of power—something like eight horse-power at 100 volts—is being consumed to produce a small and tardy effect in four patients. This would be all very well if there was no other way of producing the effect, but, fortunately, owing to recent improvements, there is. The inefficiency of the original method depends mainly on the great distance the lamp is from the patient ; the intensity of the rays diminishes as the square of the distance, and this is not wholly compensated by the concentrating lenses, for these alone serve to cut off part of the radiation.

The Lortet and Genoud arc lamp is a step in advance. A small arc lamp (10 ampères) is fitted in a metal case or screen, in which is a double quartz window, between which a stream of water circulates. The patient, by his own effort, presses his face or affected area against the outer quartz window, so that his skin will not be much more than 2 to 4 inches from the light, which is placed close to the inner quartz window. The separating media are two layers of quartz and a stratum of water. The water is essential for cooling purposes. The Finsen-Reyn lamp (Fig. 184) has twice the candle-power of the Lortet-Genoud ; it is also self-regulating, and it is provided with a concentrator.

With this lamp a sitting of fifteen to twenty minutes is

found to be sufficient, and the surface of skin affected is considerably larger than with the older form, in the ratio of about 9 to 2 square centimetres. The cost of the apparatus is about £25, and it consumes at 100 volts about  $1\frac{1}{4}$  horse-power, or one Board of Trade unit (3d. to 9d.) per hour. Four patients can be treated per hour as with the older apparatus.

There are, therefore, physical reasons for preferring

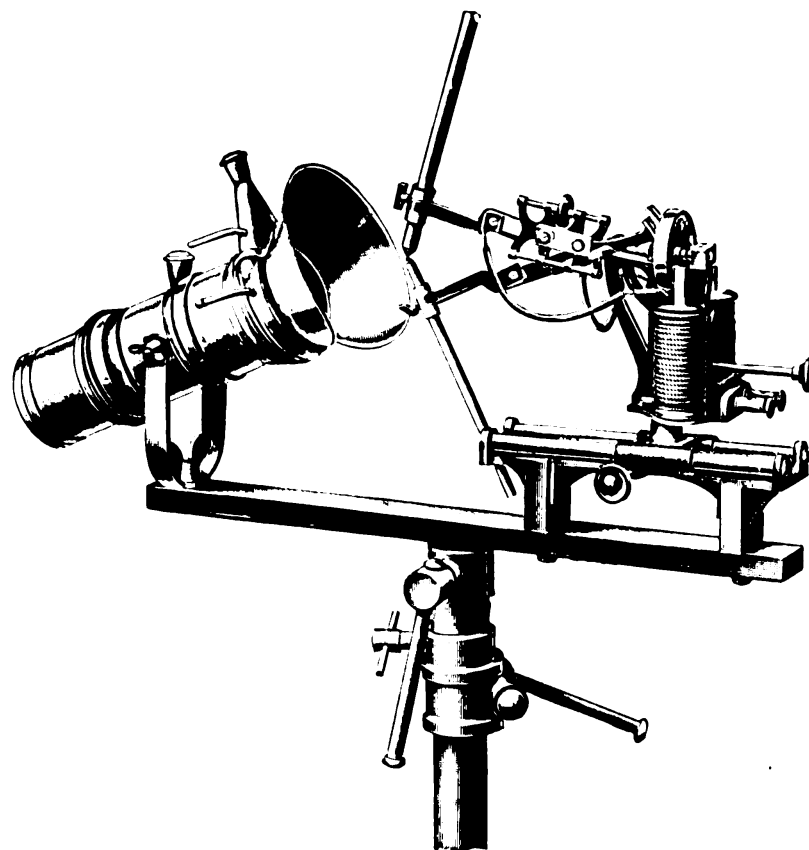

FIG. 184.—THE FINSEN-REYN LAMP.

this lamp, and the clinical results appear to be quite as favourable as those obtained by the older form, though some observers believe that its action is more superficial.

In the Bang lamp (Fig. 185) advantage has been taken of the fact that the spectrum of iron is very rich in violet and ultra-violet lines, and Dr. S. Bang has constructed his lamp to burn with iron instead of carbon electrodes (there



is no difficulty in this); he also cools the electrodes by making them hollow and by passing a current of water inside them, or else he suspends them in a vessel containing water (Fig. 186). It is stated in the *British Medical*



FIG. 185.—DR. BANG'S DERMO PATTERN.

*Journal*, January 4, 1902, quoting a German authority, 'that Dr. Bang's lamp need not be larger than an ordinary tablespoon, compressing and supporting apparatus included, and that its cost would be about £3. While the light from an ordinary arc lamp can kill cultures of *Staphylococcus pyogenes aureus* in four and a half minutes, the light of Dr. Bang's lamp, under similar conditions,

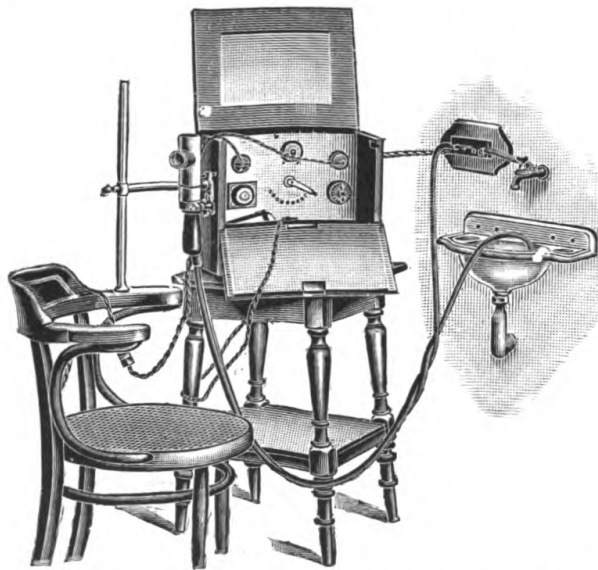

FIG. 186.—INSTALLATION OF DERMO LAMP.

can kill them in a little less than four seconds, thus giving a bactericidal power sixty times stronger than that of the ordinary arc lamp. It is stated that with his apparatus, in both healthy and lupoid skins, a marked light

erythema of many days' duration may be produced with 5 ampères of current over an area 4 inches square in five or even in three minutes, and as strong as that hitherto obtainable with 60 ampères of current in seventy-five minutes.'

Probably the Lortet-Genoud lamp would give better results if it were fitted with iron electrodes.

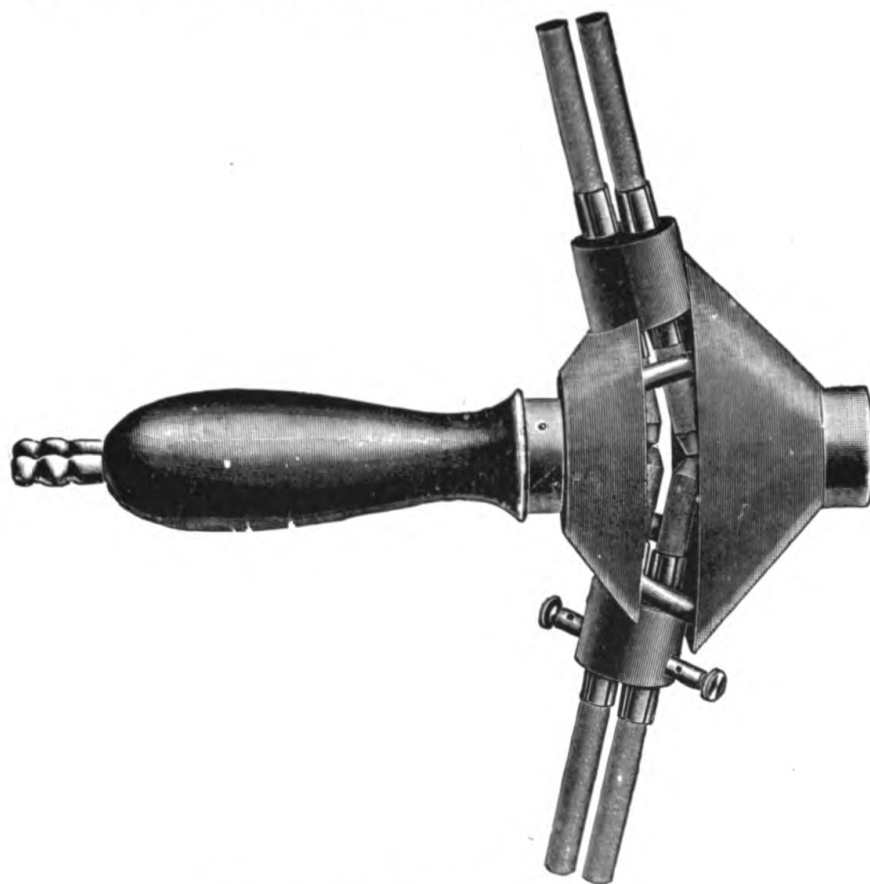

FIG. 187.—DR. STREBEL'S LAMP.

In the Strebel lamp (Fig. 187) there are four carbon poles with cores of iron dust ; there are thus two arc lights, which necessitate a difference of potential of about 90 volts, so that the lamp can be run off a 100-volt circuit with but little added resistance and consequent economy. The carbon gives the high candle-power and the iron the ultra-violet rays.

None of the above-mentioned lamps can, however, approach in simplicity and ease of regulation the condenser spark or Görl lamp. This lamp can be obtained from Schall, 55, Wigmore Street, or from L. Miller, 93, Hatton Garden, E.C. It must be attached, with its condenser, to the secondary terminals of the Röntgen-ray induction coil, and, being held in the hand either of the doctor or patient, is pressed against the affected area ; the open

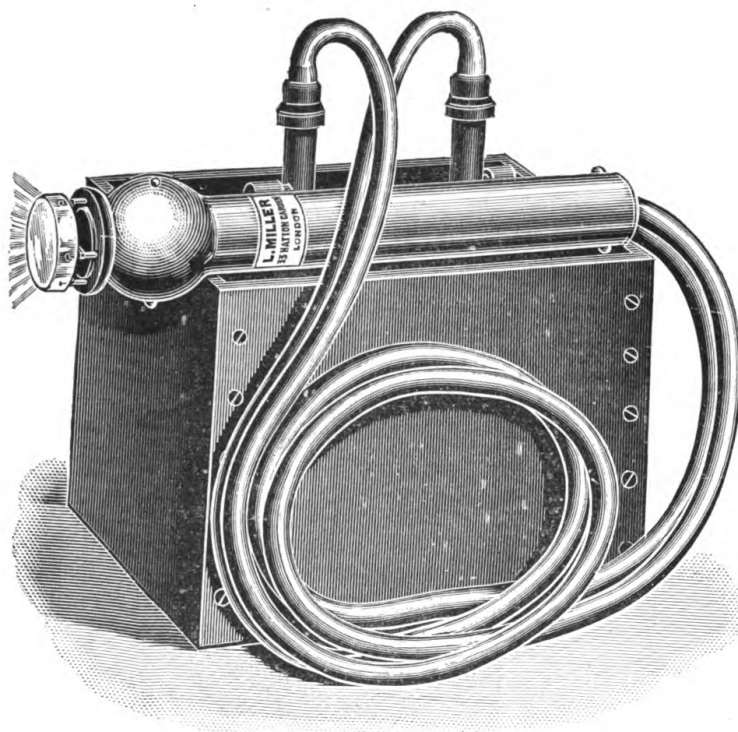

FIG. 188.—CONDENSER SPARK LAMP.

end of the lamp must first be fitted either with a piece of rock-salt or ice. The ultra-violet rays have thus *only one* intervening solid compressing agent to pass through, instead of having two layers of quartz and one of water; as in the Lortet-Genoud lamp. Further, the compressor used (rock-salt or ice) is far more transparent to the ultra-violet rays than quartz, and as there is only one layer it is possible to bring the source of radiation much nearer the skin—within an inch, or less, using a disc of rock-salt

$\frac{3}{8}$  inch thick. For all these reasons, and also having regard to the fact that the experiments before described show that the condenser spark radiation is *ab origine* more ultra-violet than the arc, we should expect physically a greatly intensified effect, and this has been borne out clinically in the electrical department of the Edinburgh Royal Infirmary, the exposure necessary having been reduced from fifteen minutes with the Lortet-Genoud to five with the spark lamp. The crackling noise of this lamp is a disadvantage, and it is only suited for superficial cases, for the high refrangibility of its rays renders them less penetrative.

One of the many advantages of this lamp is that, owing to its very feeble radiation of heat, no cooling medium is required; the finger may be held within  $\frac{1}{2}$  inch of the spark without experiencing any undue sense of warmth. All the forms of arc lamp labour under the grave disadvantage of being more energetic radiators of heat than of ultra-violet light, and they must therefore be robbed by some means or other of their radiant heat, and this cannot be done without in some measure intercepting also their ultra-violet rays.

Rock-salt or ice (see p. 374) form the best compressing media. Ice has the advantage of being easily procurable; the anæmia produced by its pressure is intensified by its chilling effect, and it is opaque to radiant heat.

Rock-salt is more transparent to ultra-violet light than ice, and it can be used in thinner slices— $\frac{1}{4}$  to  $\frac{3}{8}$  inch—and the same piece, if taken care of, will last an indefinite time. Further, the affected part is kept dry, and the patient is not annoyed by the constant trickling of the water down the face from the melting of the ice. Pure transparent rock-salt, is, however, difficult to obtain. Dr. Hugh Walsham's paper (*Lancet*, February 1, 1902) on the condenser spark lamp and the use of ice should be consulted; the author's paper in the *British Medical Journal* of March 22, 1902, may also be referred to.

**Radium Radiations.**

The discovery of the radio-activity of uranium was made by Becquerel in 1896 ; this discovery was an important one, which may have far-reaching consequences. Madame Curie in 1898 separated radium from pitchblende ; other radio-active bodies are thorium, actinium, and polonium. The following is a table of the known radio-active elements :

	<i>Atomic Weight.</i>		
Uranium	-	238	- Hexad.
Thorium	-	232	- Tetrad.
Radium	-	225 or 258	- Dyad (Barium).
Polonium	-	?	
Actinium	-	?	

They are all, it will be observed, of very high atomic weight. Radium far transcends the others in radio-active power ; in its pure state it is about one million times as active as uranium.

The distinguishing radio-active properties of radium are that it gives off an emanation and three kinds of rays :

*a* rays.

*β* rays.

*γ* rays.

It continually emits light, and acts as a perpetual candle ; it maintains itself at a higher temperature than its surroundings, and it continually emits heat.

The ' emanation ' is a heavy luminous gas which can be conducted along tubes, can be liquefied by intense cold ( $-150^{\circ}$  C.), can traverse thin metal plates, but not mica. Whatever substance it touches it renders self-luminous. The ' alpha ' rays are projectiles shot out by the radium as though it were a maxim gun, but with this difference, that the bullets are very small, and that they travel very fast. They are positively-charged particles of mass about twice that of the hydrogen atom, and it is conjectured that they consist of helium.

The 'beta' rays are, to all intents and purposes, the kathode stream of a Crookes tube (p. 315); this stream consists of particles only the one-thousandth of the mass of a hydrogen atom, called electrons; they are units of negative electricity, and, owing to their small size, they are more penetrative than the 'alpha' particle; they travel with almost the speed of light.

The 'gamma' rays are the most penetrative of all, and will traverse a foot of solid iron; as they have not been deflected by a magnet, they differ essentially from the 'alpha' and 'beta' rays, which can be deflected. They are probably ethereal vibrations somewhat akin to, though not identical with, the X ray. They are only present in small quantity.

All the three varieties of rays render the air a conductor of electricity, excite fluorescence, and affect a photographic plate.

It is with the 'beta' and 'gamma' rays that we are principally concerned in practical medicine, for the 'alpha' ray and the emanation are easily absorbed, and have little penetrative power.

Experiments have been made by Pfeiffer and Friedberger on the bactericidal action of radium rays. The micro-organisms of cholera, of typhoid fever, and of wool-sorters' disease were destroyed by a three days' exposure to 25 milligrammes of radium bromide, placed in close proximity. This result is not very encouraging; still, it must be remembered that the Röntgen rays have no bactericidal effect, though their beneficial effects in certain diseases cannot be doubted.

Though the micro-organisms of certain diseases are not very susceptible to radium rays, the human tissues are. It is unsafe to carry radium about for long in one's pocket. Several cases are on record of an inflammation and ulceration of the skin following such a procedure; even the carrying of an active specimen daily in a glass tube from one patient to another may, it is said, set up an inflammation similar to that induced by an improper use of the

Röntgen rays, and any ulcer formed is highly intractable, and may last for weeks or months.

Goldberg and London report in the *Dermatol. Zeit.*, Band X., the following experiment. Seventy-five milligrammes of radium bromide were applied to the arm for three hours. On the fourth day a red area appeared which developed a zone of infiltration around it. A bulla formed, which ulcerated; this increased in size, and acquired heaped-up edges and a sloughy base. On the sixteenth day new patches formed on the same arm similar to the original one. Two weeks later patches appeared on the chin, thigh, and right hand. The original sore was unhealed three months later, in spite of treatment. In two cases of rodent ulcer successfully treated, exposures were given of one hour and a half in one case and one hour in the other, followed by exposures of half an hour and an hour respectively.

On the other hand, Van Beuren and Zuisser (*Medical Electricity and Radiology*, May, 1904) tested the action of 12 milligrammes of radium in a glass tube on the forearm by keeping it in contact for one hour and a half with a linen handkerchief intervening; the result was negative. They also failed with the same preparation to obtain positive evidence of any bactericidal effect. It must be noted that the amount of radium used was small, and that the glass would absorb all the alpha rays and a proportion of the beta rays also. The author has applied 15 milligrammes in a glass tube to a lupus patch on the face for half an hour five times a week for a fortnight without producing an undue reaction.

E. S. London tested the effects of the rays on mice; reddening of the ears and blinking of the eyes appeared on the third day; general torpor and paralysis followed, with death on the fourth or fifth day; the skin and brain were the parts most affected. London has also discovered that persons who are almost blind can perceive light when radium is brought near, and that people with perception of light, but not of form, can detect the shape of objects

which are in the neighbourhood of a fluorescent screen ; he thinks that there may be in this a possibility of teaching such blind people to write or draw. Persons who are totally blind are unaffected by radium. The position of the radium can, he reports, be detected with covered eyes, and even when the box is held behind the head. The first part of this experiment is easily confirmed, and the fluorescent effect of the radium on the media within the eyeball may even be perceived through half a dozen coins, provided one has been for some little time in the dark ; but I have failed to repeat the latter part of the experiment.

The chief physiological effects of radium, so far as at present investigated, can be arranged in three groups :

1. Effects on the skin, producing inflammations and ulcers.

2. Effects on the nervous system, producing paralysis and death.

3. Luminous effects produced in the partially blind.

Other effects of radium are chemical, electrical, colour, and photographic. Bohn has also noted some curious results produced by the action of radium on the growth of embryos ; the growth is retarded, and monsters may be produced. Amongst the chemical effects are the liberation of iodine from iodoform, the production of ozone, the conversion of corrosive sublimate into calomel, and the decomposition of water. Strutt has shown that an insulated body containing radium will, if placed in a good vacuum, become charged positively ; there is a continual production of positive electricity due to the discharge of the negative electrons.

Photographs of the human tissues taken by the author with radium show no differentiation between the hard and soft parts : the bones do not appear, nor can they be seen on the fluorescent screen ; the inference is either that the photographs are taken almost wholly by the beta rays, or that the gamma rays are not X rays. It is not, therefore, to be expected that the radium rays can take the



place of the X rays in diagnosis. Barium platinocyanide is the substance which fluoresces most brilliantly with radium ; zinc blende, diamonds, kunzite, sand-paper, etc., are also rendered luminescent.

Thorium has only about the one millionth of the radio-activity of the best radium ; but as it is cheap and easily procurable, it has been used in plasters or in inhalations as a substitute for radium.

The human tissues appear to possess the property of emitting rays (Blondlot's N rays) which increase or may diminish the luminosity of a phosphorescent screen or of an electric spark ; as they are chiefly emitted by the muscles and nerves when physiologically active, they may serve to outline these tissues and to aid in the localization of tumours of the brain.

Blondlot and Charpentier's results are not, however, so far generally accepted in Great Britain, and the matter is still *sub judice*.

CHAPTER IV  
RÖNTGEN RAY, FINSEN LIGHT, AND  
RADIUM THERAPEUTICS

THE therapeutic uses of the Röntgen rays seem likely, in course of time, to become even more serviceable to mankind than its applications in surgical and medical diagnosis. The rays are already being used with more or less success in the following diseases, amongst which are some of the most formidable of those which afflict the human race.

- Malignant disease of all kinds.
- Rodent ulcer.
- Lupus vulgaris.
- Lupus erythematosus.
- Enlarged glands—scrofulous or otherwise.
- Eczema—chronic.
- Psoriasis.
- Sycosis and favus.
- Mycosis fungoides.
- Xeroderma pigmentosum.
- Chronic ulcers.
- Acne.
- Trachoma.
- Neuralgia.
- Warts.
- Hypertrichosis, etc.

There are several cases now on record of the successful treatment of carcinoma by, amongst others, Andrew

Clark (*British Medical Journal*, June 8, 1901); Johnson and Merrill—six cases of epithelioma (*Phil. Med. Journal*, December 8, 1900); and Dr. Lewis Jones (*Lancet*, February 22, 1902). In the latter case the patient suffered from an ulcerated cancer of the breast measuring 4 by 5 inches. X-ray treatment was begun on November 14, 1901, and ten minutes' exposures four times a week were given until January 17, 1902, the total number of exposures being seventeen. After a few days of the treatment signs of healthy cicatrization began, gradually extending round the margin; the new epithelium was deeply pigmented. Since the suspension of the treatment healing has gone on steadily, and now, with the exception of 1 square inch in the centre, there is a firm and healthy scar.

A patient suffering from an ulcerating scirrhus of the breast consulted the author in October, 1902. The ulcer measured 3 by 3½ inches. After twenty-three seven-minute exposures, spread over a period of three months, the ulcer was healed, being entirely covered with delicate epithelium. The symptoms of pain, stiffness, etc., had disappeared after the first few exposures. This patient returned in November, 1903, with a hard lump in the other breast, which was commencing to ulcerate in two places. The ulcer which had been treated a year before was now covered with firm hard skin. This is a case, then, in which the X rays caused complete healing of a large malignant ulcer, the patient being under observation for more than a year afterwards. The author has had another similar case.

In the electrical department of the Royal Infirmary twenty cases of scirrhus of the breast have been treated; of these, eleven were much improved, and nine ceased coming or were not improved. Of twelve cases of epithelioma of the mouth and lower jaw, four were improved and eight not improved. These cases are amongst the most difficult to treat by X rays; radium in a sealed glass tube might, on the other hand, be intro-

duced into the mouth and made to lie in apposition with the affected part. Cases of cancer affecting the rectum, the uterus, or cervix, are also very difficult to treat by X rays, and would be more suitable for radium or for high-frequency currents. Fig. 188A represents Dr. J. Macleod's ingenious radium applicator.

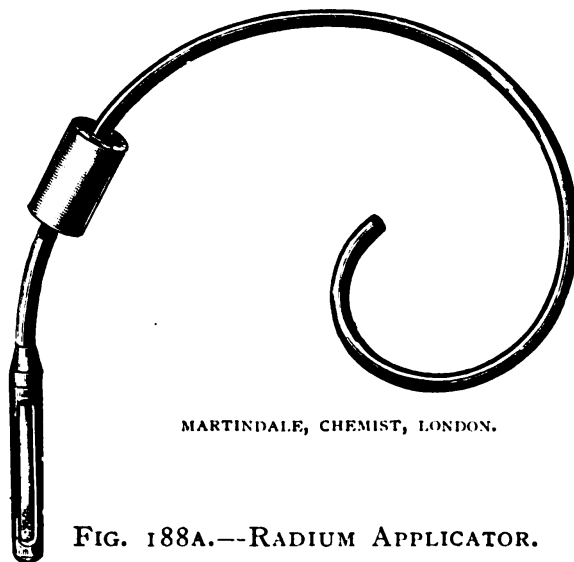

MARTINDALE, CHEMIST, LONDON.

FIG. 188A.—RADIUM APPLICATOR.

A case of carcinoma of the stomach has been under treatment by the author by X rays. A quarter of an hour before each application 7 grains of quinine were administered, so as to obtain internal fluorescence in close proximity to the growth. The patient had eleven exposures, after which, owing to reddening of the skin, the treatment had to be suspended. Under this treatment the patient decidedly improved; the pain was lessened, the tenderness to pressure disappeared, she slept and ate better, and got out of doors every day. Whether the administration of the quinine played any useful part is doubtful, but in the author's opinion, which is strengthened by a case of malignant disease of the bladder, treated in the same way and distinctly benefited, it was of value. Dr. J. Morton, who suggested this method of producing internal fluorescence, has also employed æsculin in doses of about 1 grain. Radium may be used

instead of the X rays to excite the fluorescence. Dr. Morton speaks very highly of this method.

The clinical results of the X-ray treatment of malignant disease are :

1. In nearly all cases to diminish or remove the pain.
2. To loosen adhesions and to cause the disappearance of the contracting and tightening sensation of scirrhus.
3. In many cases to cause an ulcerating surface to diminish in size or completely heal through the growth of epithelium from the edges.
4. To remove recurrent superficial cancerous nodules, and to dissipate entirely sarcomatous tumours.

The best results are obtained in superficial ulcerating cancers and in sarcomas. Sarcomata are more amenable to X-ray treatment than the carcinomata.

In a case of Dr. Ritchie's, of large sarcoma of the side of the neck, seventeen exposures were followed by the complete disappearance of the external tumour; the growth, however, continued internally, and the patient died. Every case of sarcoma treated by the author has improved. The following are notes of a case of Mr. Cathcart's of fibro-sarcoma treated by X rays in the Royal Infirmary.

**History.**—Six years ago a small hard swelling appeared over the right eye. A year later the patient consulted Mr. Cathcart. A small piece of the growth was removed and was found to be a small round-celled sarcoma. Nothing further was done. The tumour has now spread until it extends from above the left eye across the forehead, and over the right side of the face to a little below the lower jaw. Both right upper and lower eyelids became involved, and the patient has not been able to see with that eye for four years. Treatment began on December 24, 1903. After eleven four-minute exposures a distinct flattening of the mass was observed, and the patient's sight was restored. The patient has continued to improve.

An interesting case of Mr. Cotterill's is as follows :

A. B., thirty-nine years, Edinburgh. Recommended by Mr. Cotterill to electrical department. Admitted October 24, 1903.

**Diagnosis.**—Recurrent sarcoma of left shoulder.

**Treatment.**—X rays daily for four minutes.

**History.**—Two years ago patient noticed a small swelling on his left shoulder. It did not pain him except on pressure. The swelling gradually grew to the size of a small cocoon. On January 9, 1903, Mr. Cotterill operated, and patient was able to continue his work as a car-conductor all the summer. Last June, however, the disease began again as a small nodule, and gradually grew till, from its very size, it became uncomfortable. He again saw Mr. Cotterill on October 19, was admitted to hospital, and recommended to the electrical department. On admission his condition was as follows: There was a large diffuse swelling extending from the clavicle in front to the spine of the scapula behind. The skin over the mass was red and œdematous, and broken in two places. The swelling was soft in some parts and hard in others. Axillary glands were not enlarged.

*November 2-30.*—All pain and discomfort gone. Marked diminution in the size of tumour, especially the part anteriorly, which is much looser and not so firmly fixed to the clavicle. Patient gained  $4\frac{1}{2}$  pounds.

*December 1-19.*—Continued improvement. Whole mass greatly smaller. Broken skin healed. Patient attending as an out-patient, and has since then gone back to his work, but continues treatment as often as possible.

*May, 1904.*—Patient still at work, but attends for X-ray treatment once or twice a week.

Dr. W. B. Coley has published the following conclusions:

1. That the results in the cases thus far treated prove that the X rays have a remarkable inhibitory action upon the growth of all forms of malignant disease, and this is especially true of sarcoma.

2. That this action, in many cases of even far advanced

and inoperable malignant disease, may result in the total disappearance of the tumours, often without any breaking down of the tissues, the new growths being apparently absorbed.

3. The X rays have a very marked influence upon the pain of nearly all types of malignant tumours, causing in many cases entire relief.

Great care should be taken to avoid setting up a dermatitis (p. 402) in malignant cases; the treatment should be interrupted from time to time, for the patient will continue to improve, the therapeutic effect of the ray being, like its effect in producing a dermatitis, cumulative.

Not much trial has yet been made of radium in malignant disease. Exner, in Vienna, and David Walsh have reported favourably upon it, but Mackenzie Davidson, referring to carcinoma, says (*British Medical Journal*, January 23, 1904): 'Radium has been tried in several cases with no good results; the conclusion forced upon us is that radium, with the present method of application, is of no use whatever in carcinoma' (see also *Medical Press and Circular*, February, 1904, for paper by Dr. David Walsh).

### Rodent Ulcer.

The value of the X rays in the treatment of rodent ulcer is now well established; the hard margins recede, the surface dries up, and healthy epithelium appears. This effect appears to be due to an inflammatory leucocytosis. Where the cartilages are attacked the outlook is less favourable. Relapses are common after apparent cures, so that it is difficult to determine when the treatment should be stopped. Radium bromide (5 milligrammes) in glass tubes or in leaden cases with a window of mica can also be used. Glass is to be preferred, because it can be more thoroughly cleansed. These can be applied to the surface of the ulcer and kept in position by a bandage or a piece of plaster for half an hour or less, according to

the radio-activity of the specimen of radium. Successful results have been recorded by Mackenzie Davidson (*British Medical Journal*, January 23, 1904), Gerald Sichel (*idem*), and others.

A large surface should not be overexposed to radium, or an erysipelatous inflammation may be set up. '

Some cases of rodent ulcer have been treated by the author with the kathode breeze with good results, and in one case where the X rays had failed the breeze was successful, but the latter may also do no good. The Finsen light also does good when the necessary pressure can be borne.

### Lupus.

It must now be admitted that in the Finsen light we have a specific for lupus vulgaris. So long ago as September, 1899, Dr. Finsen had treated 350 cases of this disease, with a satisfactory result in 345. This result has been so certain and constant that there is even reason to doubt the accuracy of the diagnosis of lupus vulgaris when this method of treatment appears to be ineffective. The light treatment will only cure lupus of the skin, the hard palate, the front part of the septum nasi, tongue, and the mucous membrane of the cheek (Dr. Bie, *British Medical Journal*, September 30, 1899). This is owing to the want of penetrative power of the rays; for other cases, as well as for the superficial ones, the Röntgen rays can be used. A very large number of cases have, during the last eighteen months, been treated both by the Finsen light and Röntgen rays. Dr. Thurstan Holland, after detailing several cases—in one of which recurrence occurred after two years, treated by the Röntgen rays—makes the following remarks in the *Archives of the Röntgen Ray*, May, 1901 :

' In considering the treatment and its results there are several points worth dwelling upon.

' 1. It is not necessary to set up any dermatitis. It is sound advice to give, that on the first appearance of any



inflammatory mischief no more exposures should be made until it has quite disappeared again.

'2. A very high vacuum tube was used by me at a distance of 4 to 5 inches from the diseased area (most operators prefer a tube of low vacuum).

'3. Very few exposures were necessary to cure the two cases detailed. The first case had only seventeen primary exposures of fifteen minutes each, and two years afterwards, for a slight recurrence, six more of ten minutes each. The second case had ten exposures of ten minutes each.

'4. The fourth point is the gain to the patient. With this method there is no operation, no anæsthetic, no pain, and the resulting scars are far superior to anything of the kind I have ever seen from any other method.'

Forty-two cases of lupus vulgaris have been under treatment in the electrical department of the Royal Infirmary, Edinburgh, and of these two were at first treated by the Röntgen rays and afterwards by the ultra-violet light of the condenser spark ; in six the ultra-violet light was alone employed ; in the rest the X rays. Some cases improve very rapidly and others more slowly, but in all of them there has been a steady gain. Some cases, again, do better with a compressor of rock-salt and others with one of ice ; the latter cases are the more refractory ones. The exposures have been either two and a half or five minutes three times a week. In one case of four years' duration of lupus affecting the right ala of the nose, which presented a small punched-out patch about  $\frac{1}{4}$  inch in depth, eleven exposures of two and a half minutes each with a rock-salt compressor sufficed to bring about a complete cure. The whole time of treatment occupied, then, in producing this effect amounted to twenty-seven and a half minutes, and that without any pain or inconvenience of any sort to the patient. Surely, a few years ago this would have been regarded as miraculous.

When the Röntgen rays are employed most authorities recommend the use of a soft tube (2 to 4 inches alternative spark gap). This is correct from the physical point of

view, for it is only those rays that are absorbed that can be expected to produce an effect.

The Röntgen rays have the advantage of attacking a larger area than the light rays, but there is considerably more risk in their use, and unless great care be exercised severe and intractable dermatitis may be set up. A suitable mask of lead-foil or of thin lead should be so cut as to shade the parts that it is not desired to affect (this will not be necessary if a therapeutic tube, page 340, is used), and the patient so protected is placed about 6 inches away from a soft tube, and an exposure of about five minutes is given, and repeated about three times a week, or, in the case of a working-man, an exposure of ten or fifteen minutes once a week. Reaction (p. 402) can be hastened and the treatment shortened by first painting the affected part with tincture of iodine or pure carbolic. Considerable reaction will now follow in a day or two, with pain, swelling, and some sloughing; the treatment is suspended, and a simple dressing applied, or in more severe cases the ulcer may be covered with zinc ichthyol salve muslin, renewed once a day. Telangiectases sometimes follow this method. The Finsen light is at its best in the case of small patches situated over cartilage or bone, so that the necessary pressure can be effectively applied. The chief advantage of the light is that there is no risk of dermatitis. Adrenalin has been tried in conjunction with the light.

Radium bromide has so far proved of more efficacy in lupus than in other conditions (Dr. John MacIntyre and others). Some cases are under treatment in the Edinburgh Royal Infirmary, and are steadily, if slowly, improving; but the time has not yet come when the value of this treatment can be contrasted with that of the X ray and Finsen light. The radium is applied as in the case of rodent ulcer, and the exposure depends upon the radioactivity (which can only be tested by an expert) of the specimen used. It has been suggested that as thorium is cheap it might be made up into a plaster and applied con-

tinuously ; it is about one million times less active than radium.

It is to be hoped that medical men will not suffer the therapeutic use of these physical agents to pass into the hands of the instrument-makers, as has, unfortunately, already to some extent occurred in the photographic use of the X ray.

### Lupus Erythematosus.

We are not here on nearly such sure ground ; still, Dr. Finsen had in many cases excellent results, with permanent recovery and firm scars. Sjögren, of Stockholm, using the X rays, cured five out of seven cases ; one remained obstinate, and the seventh is not yet in a condition to be reported on. All the cases were very chronic ones, and had been repeatedly treated in other ways. The result was a patch of bright atrophic skin resembling scar-tissue. The method adopted was daily exposure until reaction set in ; then the treatment was suspended until all the scabs had fallen off (*Fortschritte auf dem Gebiete der Röntgenstrahlen*, Band V., Heft 1). Dr. R. F. Woods (*Amer. Journ. Med. Science*, December, 1901) also reports a case of lupus erythematosus entirely cured by the application of the X rays. Five applications of ten minutes each entirely eradicated a lesion which had been growing for four years. Improvement commenced at once, and after the fifth exposure the area of ulceration had healed, and was covered by a healthy cicatrix.

A case of this disease has been treated by X rays in the electrical department of the Royal Infirmary. The disease, of five years' duration, was given daily exposures of five minutes for fourteen days. This resulted in a peeling off of the superficial tissue, leaving a red stain, but on this disappearing the disease was found to be cured. Six months have since elapsed, and there has been no recurrence.

Another case of two years' duration which failed to yield to X-ray treatment was benefited by the Finsen light. A

third case treated by the kathode breeze improved to a certain point, but no further; the X-rays being then applied, the improvement continued, but the progress is very slow, and the case is not yet cured after five months' treatment in all.

### Enlarged Tubercular Glands and Joints.

Thirty-five cases of enlarged tubercular glands have been under Röntgen-ray treatment in the electrical department of the Royal Infirmary. The exposures have been of five minutes' duration three times a week. The duration of the disease has varied from thirteen years to three months. In some of the older cases many operations had been performed, and sinuses were present. Twenty of these cases were cured, twelve were improved, and three were not improved. Of six cases of tubercular joints, wrist, elbow, and knee, one was cured, three improved, and two were not improved.

### Eczema and Psoriasis.

Good results with Röntgen-ray treatment have been recorded by several observers in chronic eczema. Dr. Sjögren and Dr. Sederholm (*Fortschritte der Röntgenstrahlen* Band IV., Heft 1, June, 1901) report ten cases. The result was good in all, and in the greater number the cure was complete. The moisture disappeared almost at once, and the itching ceased. The infiltration of the skin continued to diminish after the treatment had been stopped, until at length it completely disappeared. Dr. Hahn, of Hamburg, has also had successful cases, so has Miss M. M. Sharpe. Hahn records thirty-five cases, all of which were benefited. He does not recommend the use of the rays for eczema of the scalp, unless it is desired to produce baldness. He also treated six cases of psoriasis successfully, some of them of many years' duration, but he adds that recurrence occurred in several.

On the other hand, Sjögren and Sederholm report that

two cases of psoriasis treated by them with X rays did not benefit in the least.

In a private patient, recommended by Dr. Sloan, suffering from inveterate psoriasis, I tried the ultra-violet light, but without the least effect ; perhaps this was due to the presence of the scales.

### Sycosis, Favus, Acne, etc.

Some continental observers report good results in sycosis and favus. Schiff and Freund (*Gesellschaft der Aerzte in Wien*, June, 1900) treated two cases of favus and three of sycosis with excellent results ; they state that the most inveterate cases get well in the course of a few weeks. Hahn has also reported favourable results in these diseases.

Both in sycosis and in favus the beneficial effect is due to the shedding of the hair under the action of the X rays, and to the destruction of the nests in which the staphylococci grow. Dr. N. Walker regards the X rays as our best method of treating favus. Dr. Allan Jamieson has been most successful in arresting and curing the intractable diseases mycosis fungoides and xeroderma pigmentosum ; in the former disease the X rays constituted the sole means of arrest known. Dr. Greig, of Dundee, has been similarly successful.

Hahn has also treated cases of acne upon the face with success : the pustules dried up at once and were cured ; and a good result was obtained in two cases of acne rosacea, without, so far, any relapse (*Archives of the Röntgen Ray*, January, 1902).

### Chronic Ulcers and Sinuses.

As the Röntgen rays produce vascular changes together with growth of connective tissue, we might expect them to have a favourable influence in the above conditions. Sjögren and Sederholm (*Archives of the Röntgen Ray*, August, 1901) report four cases in which the cause of

ulceration was uncertain. The only point in common between them was that they had resisted other methods. Two cases were cured and one greatly benefited. In the case of a patient of Dr. Berry Hart's, who suffered from a pelvic sinus, and who was photographed by X rays with a probe in the sinus in the electrical department of the Royal Infirmary, it was observed that the sinus, which it had been proposed to cut down upon, now healed very rapidly of itself. The author has since then sometimes observed similar results.

Successful results have been produced by the X rays in cases of warts and in hypertrichosis; for the latter repeated very careful treatment is necessary. It is a useful adjuvant to electrolysis. Jutassy (*Archives of the Röntgen Ray*, January, 1901) reports the successful treatment of a port-wine stain by X rays.

### Trachoma.

Mr. Mayou and Dr. D. Walsh have reported cases of trachoma cured by the X rays and by high-frequency currents (*Archives of the Röntgen Ray*, January, 1903). A pannus often clears with rapidity, especially if recent, and it is the common thing for patients to say that they see more clearly from almost the first exposure. But even dense corneal opacity will often clear considerably, and in one case of extensive destruction and cicatrization of the cornea, in which at the commencement of treatment the patient could only see shadows, in two months she could count fingers 3 feet away.

The chief advantages of this treatment are :

1. It leaves considerably less deformity.
2. It is a painless treatment.
3. The pannus clears more thoroughly.

### Neuralgia.

That the Röntgen rays will relieve some forms of pain, and amongst these the most intractable, is undoubted. Stembo (*Archives of the Röntgen Ray*, January, 1901) was led to make this use of the rays by the discovery that sometimes patients suffering from neuralgia, when the rays are used merely for purposes of diagnosis, find a certain measure of relief. To derive any benefit, he states that the current must be strong enough to cause a light pricking sensation when the part of the body which is exposed to the rays is touched with the fingers. The sittings were carried out every second day for from three to ten minutes, and as a rule relief was experienced after the third application.

In the electrical department of the Royal Infirmary we have repeatedly observed that pain—especially that due to cancer—was relieved by exposure to the rays.

This relief of pain was strikingly brought home to me by a private case of severe and intractable toothache sent me for diagnostic purposes by Mr. Watson, L.D.S. I took several photographs of the suspected teeth (exposures from two to ten seconds); but when the patient returned in three days' time he said that he had been very much better, and that his persistent pain had practically disappeared, and so astonished was he that he asked me whether I could in any way account for it. This I had no difficulty in doing, though I had not thought of it at the time I took the photographs. A case of intractable tic douloureux of Mr. Cathcart's was, however, not in the least benefited (see p. 288).

### Comparison of the Röntgen and Finsen Rays.

1. **Nature.**—The physical nature of the X rays is still unknown; on the other hand, there is no doubt at all about the physical nature of the Finsen light. The latter consists of the blue, indigo, violet, and ultra-violet portions

of the spectrum. When white light is passed through a prism it is decomposed into seven visible colours. These colours are usually termed as follows :

Visible	}	Red.	} Finsen rays.
Spectrum		Orange.	
		Yellow.	
		Green.	
		Blue	
		Indigo	
		Violet	
Invisible ...		Ultra-violet	

Judging from my own experiments and from the clinical results of others, the most active Finsen rays are the invisible ultra-violet. The blue and violet rays will pass through glass, the ultra-violet will not, and, clinically, we find that glass is a very efficient screen to the Finsen effect, and that if a glass lens or compressor be used very prolonged exposures indeed are required to produce any therapeutic effect.

The ultra-violet rays differ in no respect (see p. 317) from the blue and violet, except that, owing to their shorter wave-length and higher frequency, they do not produce the sensation of light ; they can be reflected, refracted, polarized, and made to interfere. With the Röntgen rays none of these phenomena have yet been shown to be possible (Blondlot has shown that they are polarized) ; hence there are marked physical differences between the Röntgen rays and ultra-violet rays. Further, they also wholly differ in their power of penetration.

Opacity to the X rays is a question of density (atomic weight)—all light bodies are transparent ; while density has nothing whatever to do with the penetrative power of the ultra-violet :  $\frac{1}{50}$  inch of mica or gelatin is quite opaque, while 6 inches of rock-salt or ice are transparent.

In what respect, then, do the rays resemble one another ? They will in different degrees affect a photographic plate, discharge an electrified body, and produce fluorescence.



In actinic effect the ultra-violet rays take the precedence, and the rapidity of their effect depends upon the sensitiveness of the plate (partly a question of the thinness of the film). This is not the case with the X rays.

In the electrical and fluorescent effects the X rays are the more powerful ; they will, by ionizing the air, discharge a body whether charged positively or negatively, and that at a considerable distance ; the ultra-violet, unless of very short wave-length, will only discharge a negatively charged body provided with a particular metallic or other surface, and this effect is limited to a very short range. It is a surface phenomenon.

The X rays cause barium platino-cyanide to fluoresce with a yellowish-green, the ultra-violet with a brilliant green ; this difference of colour is marked.

2. **Bactericidal Effect.**—So many confusing statements have been made as to the bactericidal effect of the X rays that our judgment as to this must be suspended. The balance of evidence at present is that they have no such effect ; in fact, Wolfenden and others state that the growth of bacteria is positively stimulated by the Röntgen rays. Ultra-violet light has a marked bactericidal effect (see p. 378).

3. **Pathological Effect.**—The Röntgen rays produce important vascular and trophic changes, which have been noted by Gassmann, Jutassy, Grouven, and others, and these changes seem to be more rapidly brought about by tubes of low resistance. One of the most curious facts in connection with X-ray dermatitis is the retardation in its appearance ; it may not come on for days or even for two to three weeks after the exposure.

Hyperæmia is first produced ; this may pass away, but if the exposures have been sufficiently prolonged, and in susceptible patients, all varieties, from an erythema to a purulent dermatitis attended even by necrosis and the formation of intractable ulcers, may follow. The minute changes consist principally in degeneration and vacuolation of the endothelium of the bloodvessels, with thicken-

ing of the intima, leading eventually to thrombosis, in disappearance of the elastic tissue and muscle fibres, with formation of dense bands of connective tissue. In addition, curious trophic changes, such as brittleness and falling out of the nails and hair, may occur. Pigmentation of the skin is common.

In X-ray operators a chronic form of atrophic dermatitis of the back of the hands is apt to occur; the skin becomes dry, of a dark-red colour, and cracked; and small warts may appear; the nails are markedly affected. No treatment has so far been successful in curing this disfiguring disease, and cases are on record in which epithelioma has developed.

The ultra-violet rays produce very quickly a slight hyperæmia or erythema, which as rapidly passes away. No case of destruction of healthy tissue has, so far as I am aware, been recorded, but I have observed the absorption of cancerous nodules under their use. Pigmentation may be produced.

The effect of these rays falls most heavily upon the bacilli present, the effect of the Röntgen rays upon the tissues.

## CHAPTER V

### HIGH-FREQUENCY CURRENTS

THESE currents, though known for the last twelve years, have only recently come into prominence in practical medicine. We owe their introduction to Tesla, Elihu Thompson, and D'Arsonval. The essential differences between high-frequency currents and currents developed by an alternating current dynamo or an induction coil are that the alternations or reversals (frequency) are far more rapid and the electro-motive force exceedingly high. Thus, the alternations produced by a Neef's hammer attached to an induction coil may be some fifty a second, or with a Wehnelt interrupter some thousands, and the electro-motive force may rise to some 50,000 or more volts ; but the alternations of the high-frequency current may attain millions per second, and the electro-motive force may reach a million or more volts.

#### **Mode of Production of High-Frequency Currents.**

By means either of a static machine, an induction coil, or an alternate current transformer, one or two Leyden jars or condensers are charged with electricity ; the electricity is permitted to discharge through a coil of very thick copper wire (solenoid). Accessory but not essential devices are further used to increase certain effects (Fig. 189).

An induction coil should be preferred to the static machine ; the terminals of the coil are connected to the inner coatings of the two Leyden jars, and the discharge

by spark occurs between two zinc balls enclosed in a box to deaden the noise and shade the light (Fig. 195). The outer coatings of the jars are attached to the ends of the coil of wire.

The alternate current transformer consists essentially of a closed iron circuit induction coil (Fig. 190) fed by an alternating current (Koch and Gaiffe); a suitable switch-board with a choking coil is also required (Fig. 191), and, if it be desired to excite Röntgen-ray tubes, a rectifier must also be provided (Fig. 192).

With this apparatus no interrupter is required, and very

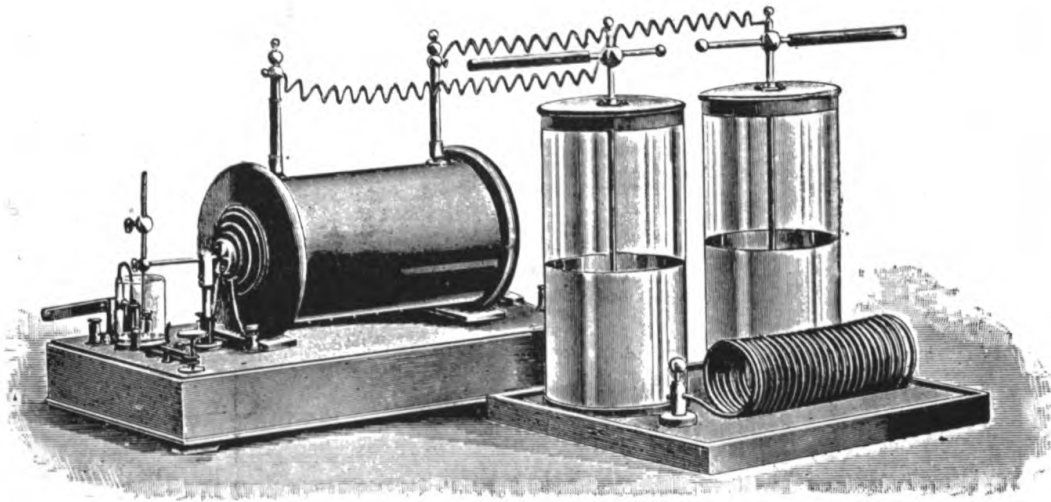

FIG. 189.—LEYDEN JARS CHARGED BY COIL.

powerful effects can be produced; but it is expensive, the rectifier may in time give trouble, and it can only be used when the alternating current supply is laid on.

The induction coil charges the jars, which then discharge across the spark gap, and this discharge is of an oscillatory nature and of high frequency; corresponding oscillations occur in the outer coatings of the jars and in the solenoid.

This solenoid may be used alone for drawing off current for patients, or it may be made the primary of another induction coil with either oil or air insulation (Fig. 193).

Tesla used the oil induction coil, but the air insulation induction coil introduced by D'Arsonval, and called the bipolar transformer, is more generally used (Fig. 194). The latter is a bulky and imposing instrument consisting of a large cylinder on which the secondary wire is wound, and round it, but separated from it by an air-space, are a few turns of a thick primary wire supported on insulating legs; the latter, after the manner of a sledge-coil, can be

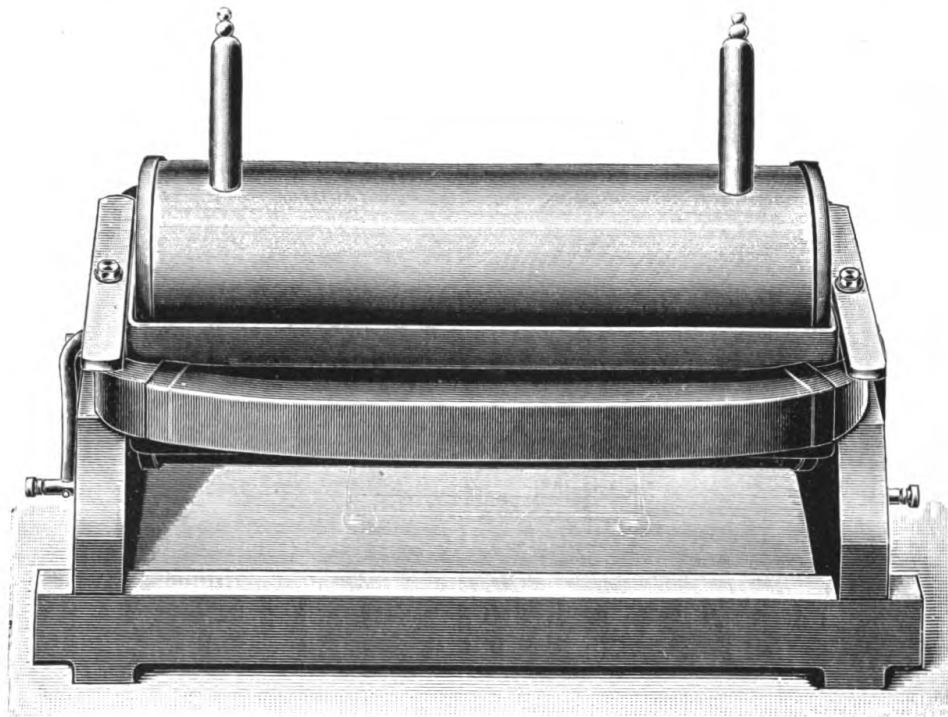

FIG. 195.—CLOSED IRON CIRCUIT TRANSFORMER (Schall).

moved along the axis of the secondary wire. The patient is treated by a wire attached to one terminal of the secondary, while the other terminal is either earthed or also attached to the patient (bipolar-method). Dr. Oudin (*Annales d'Électrobiologie*, July-August, 1900) thus expresses himself regarding the bipolar air coil: 'When we wish to administer general high-frequency treatment to a patient, I do not think that we must attach much impor-

tance to this *bipolar* character, which must perforce exist when the efflux from one end of a single resonator is directed upon an individual. For at every instant when a positive influx passes to such a capacity (p. 198) as the body of a patient, the capacity has induced upon it a negative potential, and *vice versa*. But in making local

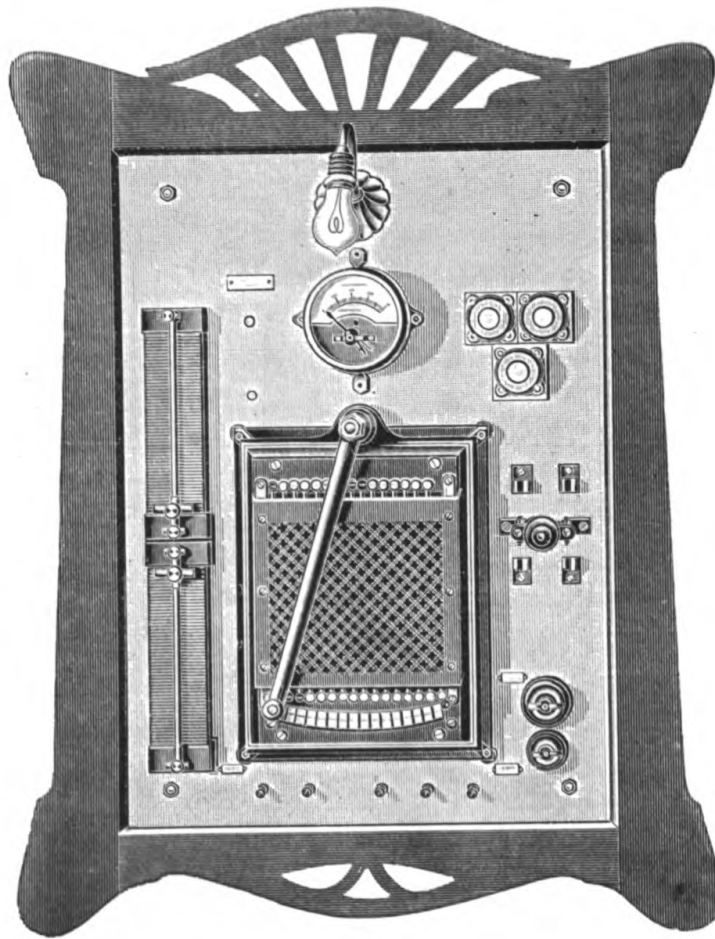

FIG. 191.—SWITCHBOARD FOR TRANSFORMER (Schall).

applications we get a zone of greater density when a bipolar coil or resonator is used.'

Dr. Oudin has invented a resonator (Fig. 195) which intensifies, at the expense of the current-strength, the electro-motive force of the high-frequency current. A

long coil of copper wire is wound round a cylindrical framework of insulating material; the successive turns must not be too close to each other. When a proper length of this wire is connected to one end of the thick wire solenoid, the resonator, to use an acoustic analogy, plays the part of the sounding-box of a tuning-fork, and vibrates in unison with the solenoid, so as to greatly intensify the effect. Some means, such as a sliding contact, must be provided whereby a proper length of the resonator

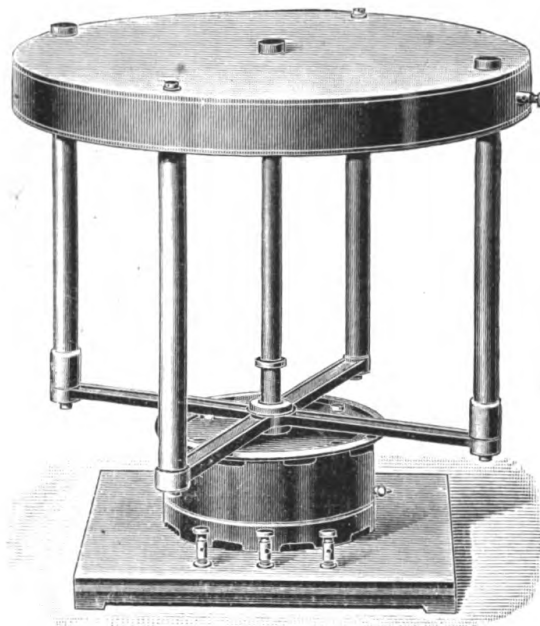

FIG. 192.—RECTIFIER FOR RÖNTGEN-RAY WORK (Schall).

may be included, and when the solenoid and resonator are thus properly tuned the upper end of the resonator and the wire coming from it to the patient will fairly sparkle and glow with the incessant electrical discharges.

There are three chief methods of applying the high-frequency currents.

1. Local applications.
2. 'Auto-conduction.'
3. 'Auto-condensation.'

Local applications can be made by directly connecting the patient by means of wires and electrodes with either end, or with a certain number of spirals of the solenoid ; the patient is thus placed in parallel, and, owing to the great self-induction of the solenoid, he will be traversed by the high-frequency current (the ohmic resistance is of less importance than the inductive resistance) ; or he may be treated by approaching him (effluve) or by touching him

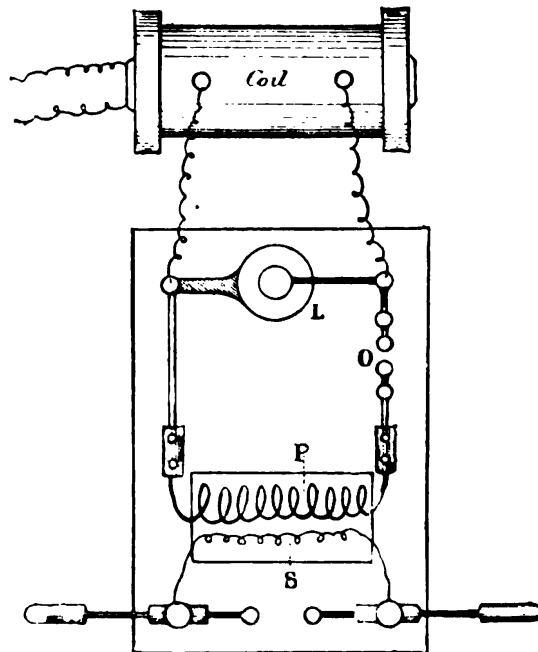

FIG. 193.—APPARATUS FOR PRODUCING ELECTRICITY OF HIGH POTENTIAL AND RAPID ALTERNATION (Tesla).

L, Leyden jar ; o, discharger ; P, primary wire ; S, secondary wire.

with an electrode attached to the resonator or bipolar transformer. There are various kinds of high-frequency electrodes (Figs. 196 and 197)—sharp-pointed for producing the effluve, or enclosed in glass sheaths to diminish the effect (condensing electrode) ; or a tube containing a conducting liquid or a vacuum tube to produce the X ray. The latter tubes seem just now to be in favour (Fig. 198).

In 'auto-conduction' the patient is placed inside the



solenoid (Fig. 199), and he plays the part of the secondary of an induction coil, and becomes the seat of induced currents.

In 'auto-condensation' the patient is made to take the place of one of the coatings of a condenser or Leyden jar. On a couch is placed a backing of sheet metal; over this is laid an insulating mattress of rubber or felt under the

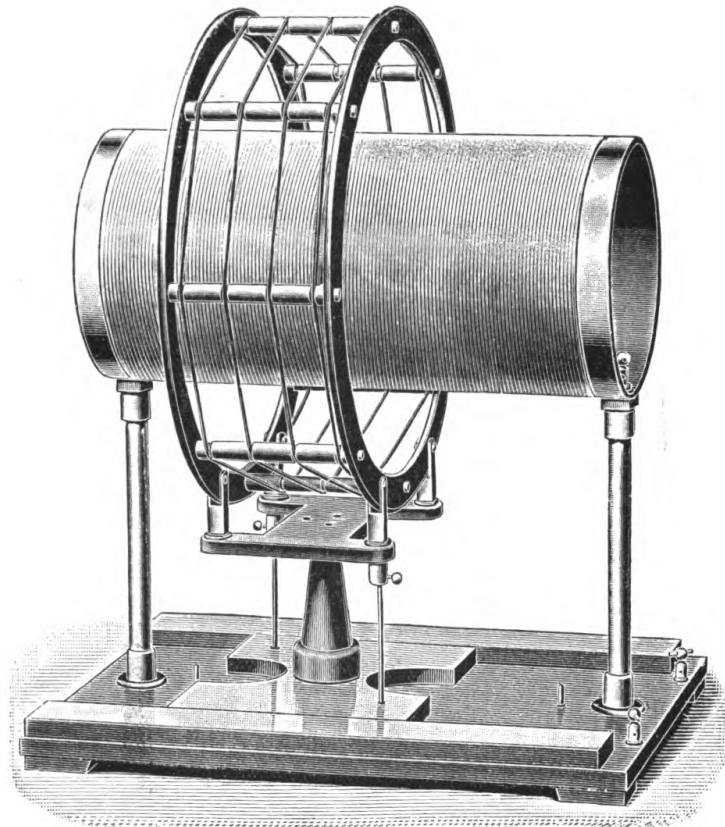

FIG. 194.—D'ARSONVAL'S BIPOLAR TRANSFORMER.

ordinary cushions. The metal sheet is connected either to one end of the solenoid or the resonator; the patient lying on the cushions becomes, if connected to earth, oppositely charged to the metal plate. The mattress represents the glass or dielectric. On the couch there are metal handles connected to earth (gas or water pipe) or to the

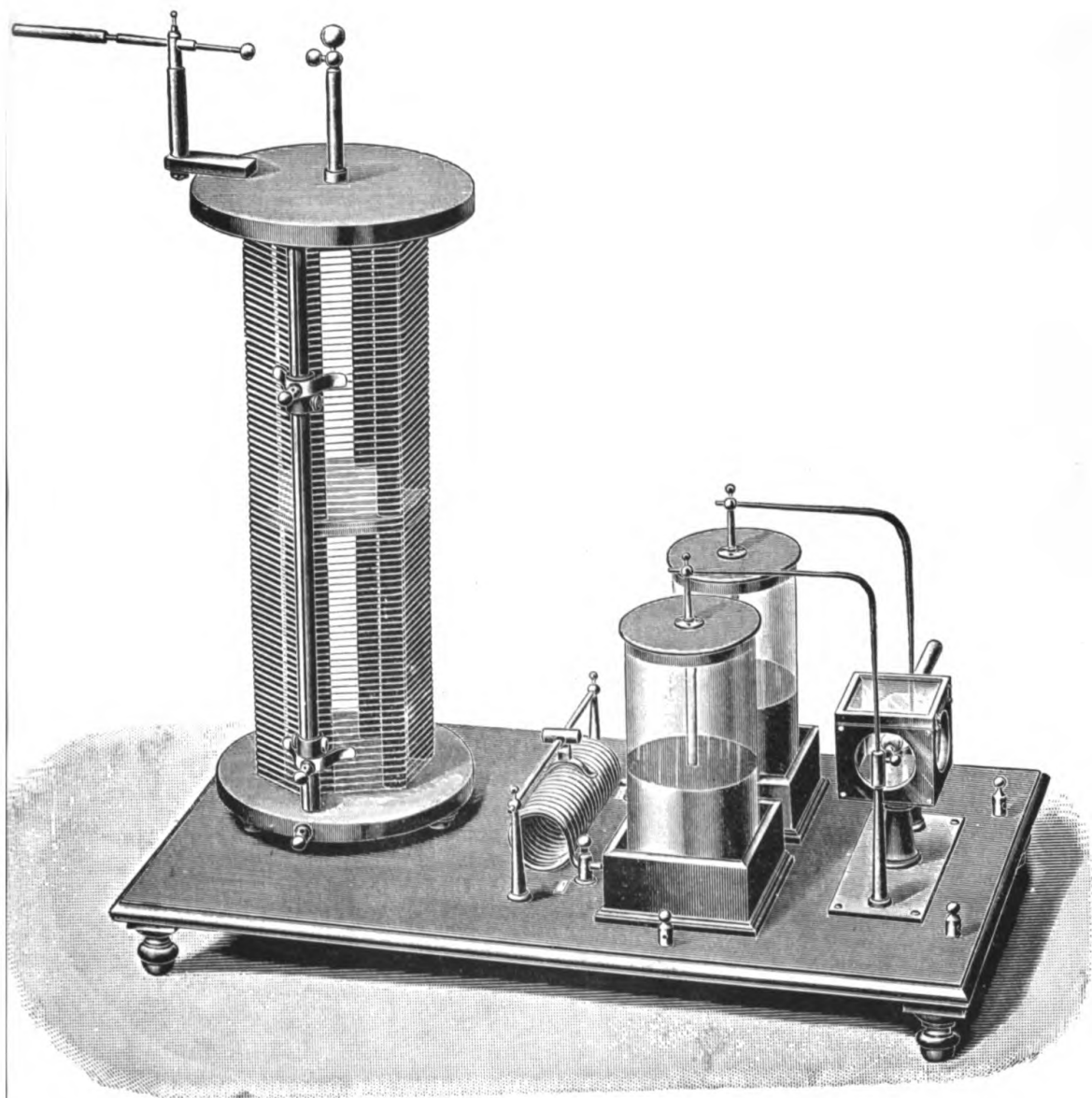

FIG. 195.—OUDIN'S RESONATOR AND SOLENOID.

other end of the solenoid ; the patient grasps these. At every oscillation of the current the patient becomes charged and discharged with electricity of opposite sign. To measure the strength of the high-frequency currents

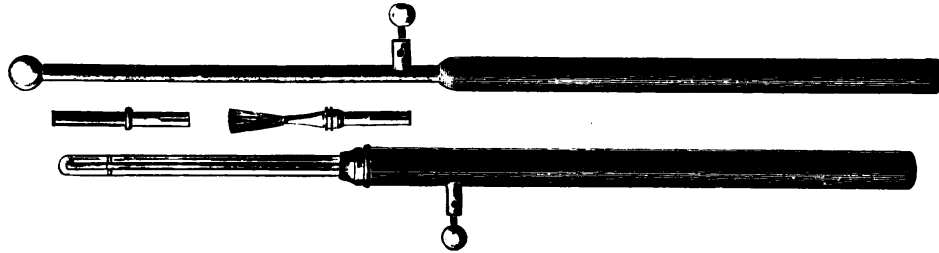

FIG. 196.—HIGH-FREQUENCY ELECTRODES.

a hot wire milliampère meter is used (Fig. 200) ; by the heating and consequent expansion of a fine wire the current-strength can be indicated. (A magnetic instrument would

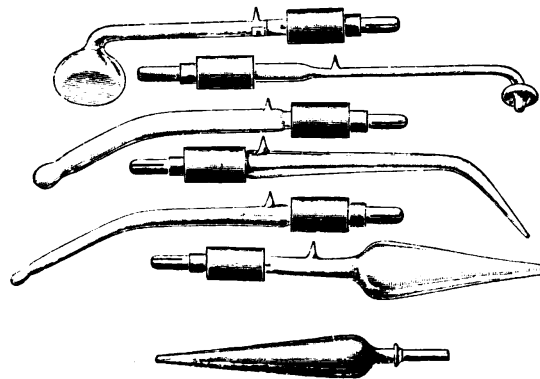

FIG. 197.—HIGH-FREQUENCY ELECTRODES.

be useless with high-frequency currents.) The current-strength varies, as a rule, from about 100 to 500 milliampères, but with the alternate current transformer it may reach 1 ampère.

### Physiological Effect of High-Frequency Currents.

So far as my own observations, made so long ago as 1890, go, almost the only sensations this current appears to give rise to are due to the passage of accidental sparks.

If both the terminal wires, or electrodes, from a Tesla coil be firmly grasped before the current is turned on, no sensation whatever will be experienced, although the whole current is passing through the body.

If one electrode be held, and the other hand be holding a vacuum tube lighted by the passage through the body of the current, no sensation will be felt unless the tube be presented to the other electrode in such a way as to draw sparks from it, when a slight tingling may be felt.

If one electrode be grasped and the bare hand be presented to the other one, a succession of vivid crackling

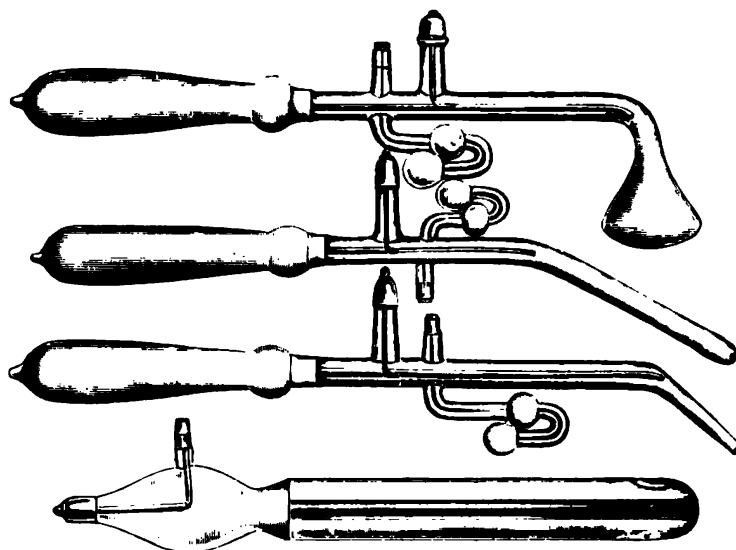

FIG. 198.—GLASS ELECTRODES FOR RECTUM, VAGINA, ETC.

sparks, or a continuous glowing discharge, according to the proximity of the hand to the electrode, will pass between them; these cause slight burning and tingling sensations, with some erythema.

If the forearm be placed between, but not allowed to touch, the two electrodes, vivid sparks will pass from each electrode to the arm; if these be kept up for a few minutes slight wheals will be formed; if, however, the electrodes be pressed firmly against the opposite sides of the arm, no sensation will be felt.

No success attended an attempt to stimulate the ulnar nerve at the elbow, one electrode being applied to the external condyle, and the other one over the nerve. The current may be passed safely through the cheeks, forehead, etc. Let each of two people grasp one of the electrodes,

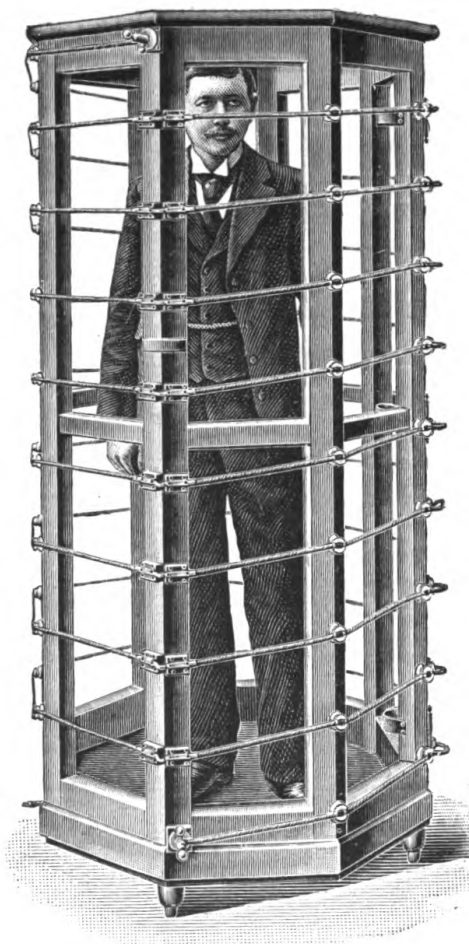

FIG. 199.—AUTO-CONDUCTION.

and let the one present a vacuum tube to the cheek of the other ; the tube will light brightly without giving rise to more than a slight tingling.

The experiment may also be performed directly : grasp one electrode and press the other one (holding it by an insulated handle) firmly against either the cheek, side of

the nose, over the forehead, closed eyelid, or mastoid process. No sensation will be experienced unless sparks be drawn; the nerves of special sense will not be stimulated. M. Cornu allowed electrical energy at the rate of nearly one horse-power to pass through his body.

The passage of this current does not, therefore, sensibly stimulate either the motor, sensory, or special sense nerves; but it does seem to slightly affect the vaso-motor ones, for slight local perspiration is a constant accompaniment, and so, too, is a feeling of warmth.

Various theories and hypotheses have been advanced to explain the immunity of the body from the effect of such currents.



FIG. 200.—MILLIAMPÈRE METER.

Thus, it is suggested that just as static electricity resides on the surface, so these alternating currents of high potential are carried along the surface, the phenomena increasing with the frequency of the alternations; if these be sufficient, one may suppose that the current will pass altogether by the skin surface, without penetrating deeply enough to affect the muscles and nerves.

It is also suggested that the tissues cannot respond to such rapid alternations. The retina, for instance, only responds to vibrations of a certain rate—those that lie between 481 (red) and 764 (violet) billions per second. All others—the dark heat rays, which stimulate the

sensory nerves, and the ultra-violet actinic rays—are without effect upon it.

In the same way, the auditory nerve can be stimulated only by musical notes which have a frequency of from about twenty per second to twenty thousand per second. If either limit be transgressed the note is inaudible. Is it not probable, then, that the motor and sensory nerves and muscles have also their proper limits of greatest rate of vibration, and that they are insensible to any stimulus that may exceed this? A degenerating muscle affords us an illustration. A healthy muscle will respond to the ordinary rapidly-interrupted current of a coil, but a muscle cut off from its nerve does not so respond; a stimulus of longer duration (a galvanic interruption) is required. The nerves of special sense do not respond to faradism. But the theory has been directly proved with healthy muscle.

Helmholtz and Koenig showed that a muscle does not respond to a stimulus that has a duration of less than 0.0015, of a second, and D'Arsonval, using alternating currents, found that if the alternations exceeded 600,000 per minute, not only did the muscles not contract, but the current was no longer perceived.

Denoyés ('Courants de Haute Fréquence,' p. 103) and D'Arsonval have shown that certain nutritive changes are brought about by high-frequency currents. Denoyés states that the influence in nutrition is shown, as regards the circulatory system, by vascular dilatation and lowering of the arterial pressure, afterwards followed by a continued elevation; as regards the respiratory system, by a greater elimination of carbon dioxide and a more active absorption of oxygen by the blood; as regards the urinary secretion, by a notable increase in the elimination of waste products; and, lastly, as concerns the heat-regulating mechanism, by an increased production of heat.

A degree of anæsthesia is, in addition to the vascular dilatation, produced by local applications. Certain toxins are attenuated, that of diphtheria (D'Arsonval). Toxoids are produced which are not only capable of pro-

ducing immunity, but are also much less poisonous than toxins. Grunbaum (*British Medical Journal*, March 21, 1903) suggests that there may be a possibility in this of treating diphtheria and tetanus by the conversion of toxin into toxoid within the living body.

### Therapeutic Applications.

The following is a list of the chief diseases for which high-frequency currents have been recommended, but their value in the treatment of these diseases and their position as a remedial agent is as yet far from being settled.

Gout, rheumatism, diabetes, obesity, tuberculosis, asthma, dilatation of the stomach, hæmorrhoids, fissure, progressive muscular atrophy, neuritis, chorea, trachoma, deafness, tinnitus, malignant disease, certain skin diseases.

Chisholm Williams ('High-Frequency Currents in the Treatment of Some Diseases'), Denoyés ('Courants de Haute Fréquence'), the author's article ('Encyclopædia Medica,' vol. xiii.) on X rays and high-frequency currents, may be consulted as to detailed accounts. Denoyés treats the subject most fully.

Chronic pulmonary consumption appears to be benefited by the application of the effluve to the affected apex. C. Williams reports forty-three cases, of which forty-two put on weight and lost all symptoms, though some of them still retained a slight cough and a few bacilli. Doumer obtained a symptomatic cure in five out of seventeen cases by the use of a powerful effluve.

Good results have been claimed in dilatation of the stomach, and particularly in hæmorrhoids and fissure. Dr. Walker refers to an acute case which was apparently cured by two applications. Doumer records a permanent cure in nine cases of hæmorrhoids associated with fissure. The author, using a condenser electrode, has found that hæmorrhoids were benefited, but he has had no case of cure. One application in the acute stage will usually bring relief. Attach a rectal condenser electrode to the resonator, bring it into contact with the anus, and gradu-



ally pass it into the rectum ; owing to the analgesic action of the current, but little discomfort will be felt. The application should last about fifteen minutes. The beneficial effect produced is due, in the author's opinion, to the slight cauterizing action of the sparks.

In chronic rheumatism and in rheumatoid arthritis the author has had better results from the sinusoidal current, and in sciatica and neuralgia from static electricity. Dr. David Walsh (*Archives of the Röntgen Ray*, January, 1903) has treated trachoma successfully. 'Twenty-three painless applications of the effluve caused the disappearance of a disease that under ordinary treatment would have lingered on for two or three years.

In malignant disease the high-frequency currents have, I think, certainly a beneficial effect, but they rank after the X rays ; they are of service when the disease affects cavities—*e.g.*, the cervix, rectum, etc.—which cannot be reached easily by the X rays. The author had an opportunity, in consultation with a surgeon, of treating in the same patient and at the same time a recurrent scirrhus of the right mamma with the X rays, and a fresh growth in the left mamma with the effluve. These applications were made on alternate days. On a re-examination with the surgeon after twenty-five applications, twelve of the rays and thirteen of the effluve, both sides alike showed improvement ; the nodules had disappeared, the lymphatics were smaller, the right arm less swollen and more movable, and the lumps in the left mamma were smaller and more diffuse. Further treatment had to be suspended owing to internal secondary growths causing œdema of the lower extremities. In a case of Dr. Macmillan's of recurrent cervical epithelioma, the X rays, which had been used with benefit, had to be given up owing to a dermatitis. The patient, being now treated with the high-frequency vaginal electrode, showed the same temporary improvement which had attended the use of the rays, each application being followed by a lessening in the amount and odour of the discharge and by a feeling of *bien être*.

Dr. J. C. Fergusson has reported (*British Medical Journal*, October 24, 1903) some cases of deafness successfully treated by the effluve and by auto-conduction, and the author has had a certain measure of success in a case of tinnitus.

Dr. W. F. Somerville (*Glasgow Medical Journal*, January, 1904) narrates the results of his experience with high-frequency currents in various disorders ; he has had good results in peripheral neuritis, sciatica, hæmorrhoids, chorea, etc., but has failed in rheumatoid arthritis and organic nervous disease ; his closing remarks are : ‘ There can be no doubt that in high-frequency currents we have a method of treatment of distinct value. Their power of service is marked in functional nervous disturbances and in localized vascular dilatations, but their influence over diseases of the skin suggests also that they are capable of profoundly modifying general metabolism, and that they will in time be found to have a wide range of application in the treatment of diseased conditions.’

The value of the X rays and of the Finsen light in the treatment of certain conditions is now well established, but in the author’s opinion high-frequency currents are still upon their trial, and time alone will show whether they will prove of superior or even of equal efficacy with our older but less startling electro-therapeutic methods.

## APPENDIX

### USEFUL FORMULÆ

#### Ohm's Law.

THE current-strength in ampères  
=  $\frac{\text{the electro-motive force in volts.}}{\text{resistance in ohms}}$

The electro-motive force in volts = the current-strength  
in ampères  $\times$  by the resistance in ohms.

The resistance in ohms  
=  $\frac{\text{the electro-motive force in volts.}}{\text{current-strength in ampères}}$

#### DIVIDED OR SHUNT CIRCUITS.

In divided circuits, each branch conducts a portion of a current inversely proportional to its resistance. The conductivity of the combined divided circuits is expressed by the sum of the reciprocals of the resistances. The resistance is expressed by the reciprocal of this sum.

#### THE ENGLISH AND METRIC MEASURES.

		Length.			
<i>English.</i>				<i>Metric.</i>	
1 inch	-	-	-	=	25'4 millimetres.
1 foot	-	-	-	=	0'3048 metre.
1 yard	-	-	-	=	0'9144 metre.
1 mile	-	-	-	=	1'607 kilometres.
<i>Metric.</i>				<i>English.</i>	
1 millimetre	-	-	-	=	0'0394 inch.
1 metre	-	-	-	=	39'37 inches.
1 kilometre	-	-	-	=	0'6214 mile.

It is convenient to remember that 10 centimetres are roughly equivalent to 4 inches.

**Area.**

<i>English.</i>			<i>Metric.</i>
1 square inch	-	- =	6.4514 square centimetres.
1 square foot	-	- =	929 square centimetres.

**Capacity.**

<i>English.</i>			<i>Metric.</i>
1 pint	-	- =	0.5676 litre.
1 gallon	-	- =	4.541 litres.
<i>Metric.</i>			<i>English.</i>
1 litre	-	- =	0.2201 gallon.

**Weight.**

<i>Metric.</i>			<i>English.</i>
1 centigramme	-	- =	0.1543 grain (avoir.).
1 decigramme	-	- =	1.543 grains „
1 gramme	-	- =	15.432 grains „
<i>English.</i>			<i>Metric.</i>
1 grain (avoir.)	-	- =	0.0648 gramme.
1 ounce „	-	- =	28.5 grammes.
1 pound „	-	- =	453.593 grammes.

# INDEX

## A.

- ABDOMEN**, galvano - faradization of, 276  
**A.C.C.** (anodal closing contraction), 159  
**Accessories**, 92  
**Accumulators**, 135. See **Secondary batteries**  
**Acne**, 302, 377  
**Acute and chronic rheumatism**, 293  
**Actinomycosis**, 304  
**Adhesive electrode**, 103  
**Advantages of static electricity for X-ray work**, 333  
**Affections of brain and spinal cord**, 283  
**Ague**, resistance of body in, 189  
**Air**, ozonized, 154  
**Albuminuria**, 195  
**Alcoholic paralysis**, 213, 287  
**Alimentary system**, affections of, 295  
**Alopecia**, 302  
**Alternating currents**, 32, 121, 131, 134, 185, 270, 405  
**Alternatives**, voltaic, 267  
**Amalgamation of zinc**, 106  
**Amenorrhœa**, 299  
**Ampère**, 28  
**Ampère hour**, 142  
**Anæmia**, resistance of urine in, 193  
     of blood, 197  
**Anæsthesia**, estimation of, 219  
     faradic, 183  
     hysterical, 278  
**Analogy between water circuit and galvanic circuit**, 66  
**Anelectrotonus**, 156  
**Aneurism**, electrolysis for, 227  
     cirroid, 227  
     dangers of the operation, 230  
     Dr. John Duncan's method, 231  
     indication for electrolysis of, 229  
     resistance of blood in an, 230  
     X-ray examination, 358  
**Angiomata**, 231  
**Ani**, prolapsus, 298  
**Animal electricity**, 149  
**Anions**, 169  
**Anode**, 157, 169  
     Apostoli's use of, 244  
     bactericidal action of, 181  
     how to recognise, 15, 251  
     soothing action of, 268, 277  
**Antiseptics**, opacity of, to X rays, 360  
**Aphonia**, 279  
**Apostoli's methods**, 243  
     galvano-puncture, 255  
     operation for fibroid tumours, 249  
     requisites for, 251  
**Apparatus for electrical treatment**, 143  
**Appendix**, 419  
**Applications**, frequency and duration of, 269  
     self-, 269  
**Arc lamps**, Finsen, 374  
     Lortet and Genoud, 376  
     condenser, 380  
     Bang, 377  
     Strebel, 379  
**Arrangement of cells**, 68

- Arsonval's (D') galvanometer, 89  
 artificial muscle, 152  
 experiments on trophic action, 153, 180, 184, 258  
 sinusoidal magneto-electric machine, 121  
 Arthritis, rheumatoid, 275, 293  
 Artificial magnets, 17  
 Ascitic fluid, resistance of, 196  
 Astatic galvanometer, 83  
 Ataxy, locomotor, 286  
 Atmospheric electricity, 3  
 Atrophy, progressive muscular, 284  
 Attraction, magnetic and static electrical, contrasted, 18  
 Auditory nerve, 165  
 galvanization of, 291  
 hyperæsthesia of, 219  
 reaction of, 165  
 deafness, 419
- B.
- Bacteria, action of electricity on, 181, 184, 381  
 Bang's lamp, 377  
 Bath, electric, 272  
 Batteries, 143  
 arrangement of cells in, 68  
 care of, 104  
 choice of, 143  
 electro-motive force of, 54  
 most suitable, 143  
 portable, 146  
 Battery, bichromate, 39  
 Bunsen, 51  
 Daniell's, 48  
 dry, 45  
 excitant of, 22  
 Gaiffe's, 43  
 gravity, 49  
 Grove, 51  
 Hellesen, 45  
 internal resistance of, 58, 68  
 Leclanché, 35  
 plates of, 19  
 polarization of, 27  
 pole of, 28  
 portable galvanic and faradic, 146  
 Reiniger's, 147  
 secondary, 135  
 Battery, Smee's, 34  
 persulphate of mercury, 43  
 terms applied to a, 28  
 testing of, 108  
 Baynes, Dr., 294  
 Beard and Rockwell, Drs., 163, 188, 271, etc.  
 Benoist, Dr., radiochromomètre, 360  
 Bichromate solution, 39  
 battery, 39  
 testing of, 172  
 Bidwell, Mr. Shelford, on the Hellesen cell, etc., 46, 348  
 Bipolar application, 267, 404  
 Bird, Dr. Golding, on inter-polar action, 175  
 on chorea, 280  
 Bladder, diseases of, 298  
 Blondlot's N rays, 386  
 Blood, electrolysis of, 174  
 resistance of, 197  
 Bone, resistance of, 190  
 Bordier on tic douloureux, 288  
 Bottini's cautery, 238  
 Bottle bichromate cell, 39  
 Boudet, Dr., 297  
 Brain, diseases of, 283  
 galvanization of, 165  
 Branch circuit, 87, 125  
 Bridge, Kohlrausch's, 65  
 Bright's disease, resistance of the urine in, 193, 195  
 Bunsen's battery, 51  
 Burners for galvano-cautery, 306
- C.
- Calibration of a galvanometer, 86  
 Cancer, treatment by—  
 electrolysis, 256  
 High-frequency currents, 418  
 radium, 388, 392  
 X rays, 387  
 Capacity of accumulators, 142  
 of the body, 198  
 Capillary, electro-, theory of D'Arsonval, 152  
 Carcinoma, treatment of, 387  
 Cardew, Dr., on exophthalmic goitre, 281  
 Care of a battery, 104  
 Cartilage, resistance of, 190

- Castex, Dr., 360  
 Catalytic action of current, 180  
 Cataphoresis, 179, 274, 294, 304  
 Cathode. See Kathode rays, 315, 318  
 Cautery, battery, 68, 145  
   instruments, 307  
   rheostat, 307  
 Cells, 33. See Batteries  
   arrangement of, 68  
   essentials of, 22  
   parallel arrangement of, 69  
   simple galvanic, 25  
   single fluid and double fluid, 34, 47  
 Central galvanization, 268  
 Cerebral hæmorrhage, 283  
 Cerebro-spinal fluid, resistance of, 197  
 Charcot, Professor, on body resistance, 189  
   on the treatment of hysteria, 279  
 Charging an accumulator, 138  
 Chauveau's curves, 162  
 Chemical action in a galvanic cell, 22  
   in a secondary cell, 136  
 Chilblains, 302  
 Choice of batteries, 143  
 Chorea, 280  
 Circuit, galvanic, 26  
 Circuits, divided, 87  
   primary and secondary, 110  
 Clausius and Grotthuss, theory of, 172  
 Coils, Dubois-Reymond, 115  
   medical, 119  
   primary, 112  
   regulation of, 119  
   secondary, 112  
 Collectors, 92  
   double-handed dial, 95  
   plug, 92  
   single-handed dial, 93  
   sledge, 92  
 Coley, Dr., 391  
 Commutator and 'Cut - out,' 106  
   simple, 96  
 Comparison between galvanic and faradic currents, 132  
   between X rays and ultra-violet light, 400  
 Comparison between therapeutic effects of galvanic and faradic currents, 257  
 Compass-needle, deflection of, 81  
 Condenser, 9, 404  
   spark lamp, 380  
 Conducting wires, 102  
 Conduction, the converse of resistance. See Resistance  
   electrolytic, 167  
   in the body, 173  
 Conductors, table of, 11. See Resistance  
   for static electricity, 14, 259  
 Constant cells, 48  
   current, trophic effects of, 180  
 Constipation, 296  
 Constitutional affections, 293  
 Contact-breaker, 118, 320  
 Contact law, Volta's, 23  
   theory of electro-motive force, 23  
 Continuous currents, 33  
 Contraction, anodal, 156  
   closing, 156  
   faradic, 183  
   kathodal, 156  
   laws of, in man, 159  
   opening, 156  
   Pflüger's law of, 156  
   static, 12, 262  
   number of stimuli required per second, 184  
 Contractures, 277  
 Contremoulins-Gaiffe interrupter, 329  
 Coulomb, 29  
 Counter E. M. F. of self-induction, 113  
 Cramp, writer's and telegrapher's, 282  
 Crutch paralysis, 213, 287  
 Current, alternating, 33  
   cataphoric action of, 179, 274, 294, 304  
   catalytic action of, 180  
   collectors, 92  
   combiner, 103  
   continuous, 33  
   density of, 265  
   differences between faradic and galvanic, 132

- Current, diffusion of, 265  
 direction of, 26, 268  
 electrolytic action of, 167  
 electrotonic, 155  
 extra, 113  
 heating effects of, 26, 91, 306  
 induced, 115  
 interrupted, 33  
 lines of force around, 20  
 magnetic effects of, 26, 80  
 measurement of, 78  
 methods of measuring, 78  
 of action, 151  
 physiological effects of, 26, 148, *et seq.*  
 primary, 113  
 reversed, 267  
 secondary, 110  
 self-induction of, 113  
 sinusoidal, 121, 184  
 strength of, 28  
 transformer, 124, 132, 405
- Curve showing current of an accumulator, 137
- Curves of currents, 33  
 D'Arsonval's, 121
- Cutaneous currents, 148
- Cystoscope, 309
- D.
- Daniell's cell, 48
- Dawson Turner interrupter, 326  
 vacuum tube, 339
- Deafness, 419
- Degeneration, reaction of, 212
- Denoyés, Dr., 417
- Density of current, 265
- Depolarizers, 34
- De Watteville on electrotonus, 160
- Diabetes, 204  
 resistance of urine in, 192
- Diagnosis, 186  
 by X rays—phthisis, etc., 356  
 of feigned diseases, 220  
 resistance of body, 186, 190  
 of tissues, 186, 190  
 of urine, 190  
 of blood, 197
- Dial collectors, 92
- Difference of potential, 6, 24, 54
- Diffusion of current, 265
- Digestive organs, 295
- Dilatation of stomach, 295
- Direction of current, 26, 268
- Directions for using Milne-Murray switch-board, 129
- Diseases of women, 243  
 of the genito-urinary organs, 298  
 of the skin, 301, 396  
 principles of treatment of, 277
- Divided circuits, 87
- Dose of electricity, 90
- Double-headed dial collector, 95
- Double fluid cells, 47
- Drake and Gorham's curve, 137
- Dropsical fluid, resistance of, 196
- Dropsy, resistance of body in, 192
- Dry cells, 45
- Dubois-Reymond coil, 115  
 theory of animal electricity, 152
- Duchenne, 292, 298, etc.
- Duncan, Dr. John, on aneurisms and angiomas, 231
- Dynamo, 122
- Dysmenorrhœa, 256
- Dyspepsia, 295
- E.
- Ear, subjective noises in, 290, 419
- Earth, the, a magnet, 20
- Eczema, 274, 302, 396
- Edelmann's galvanometer, 88
- Effects, sedative, 258  
 stimulating, 257  
 trophic, 258  
 Tesla, 403
- Electric bath, 272  
 Dr. Hedley's experiments, 273, 275  
 indications for, 274
- Electric breeze (*souffle*), 153, 261  
 charge (static bath), 261  
 douche, 275  
 friction, 263



- Electric light currents, 122, 125, 131, 330, 405  
*souffle*, 261  
 sparks, 262  
 torpedo, 148, 152
- Electrical condition of living tissues, 149  
 currents. See Currents  
 department of the Salpêtrière, 260  
 machines, Holtz, Bonetti, Wimshurst, Gaiffe, 11, 261, 332  
 organs, 148  
 phenomena, Tesla and Elihu Thompson's, 404, *et seq.*  
 resistance. See Resistance  
   of the blood, 197  
   of the body, 186  
   of the urine, 190  
 stimulus, the elements in, 166
- Electricity, animal, 149  
 atmospheric, 3  
 faradic, 109, 183, 272  
 galvanic, 21, 155, 264  
 induced, 109  
 of high frequency, 404  
 one kind of, 1  
 relations to heat and light, 1  
 physiological effects of, 148  
 static, 3, 154, 258  
 surgical uses of, 221
- Electrodes, 103  
 adhesive, 103  
 Apostoli's, 251  
 carbon, 103  
 cataphoric, 180  
 high-frequency, 410  
 non-polarizable, 149  
 rectal, 297  
 standard sizes, 187  
 static, 259  
 urethral, 234  
 uterine, 252
- Electrons, 315
- Electrolysis, 167  
 anions, 168  
 anode, 169  
 body as an electrolyte, 174, 175  
 conductivity of electrolytes, 172
- Electrolysis, decomposition of  
 body by, 179  
 electro-chemical series, 168  
 electrolytes, 168  
 Grotthuss's theory of, 171  
 indications for, 229  
 interpolar action, 175  
 kations, 168  
 M. Weiss's experiments in, 176  
 of blood, 174  
 of dropsical fluids, 175  
 of muscle, 174  
 of urine, 174  
 primary, 173  
 secondary, 173  
 surgical uses of, 220
- Electro-magnets, 17  
 in ophthalmic practice, 313  
 physiology, 148  
 therapeutics, 257
- Electromotive force, 28  
 analogy to head of water, 53  
 counter E. M. F. of self-induction, 113  
 how to increase, 54  
 measurement of, 56  
 of batteries, 54  
 unit of, 28
- Electro-physics, 3  
 surgery, 220
- Electroscope, 7  
 experiments, 341
- Electrotonus, 155
- Elephantiasis arabum, 303
- Elihu Thompson phenomena, 404
- Emphysema, X-ray diagnosis, 356
- Empyema, X-ray diagnosis, 356
- Endometritis, 255
- Enlarged tubercular glands, 397
- Enlargement of prostate, 237
- Enuresis nocturna, 298
- Epilation, 223
- Erb, Professor, on R. D., 218  
 on self-application, 270
- Eustachian tube, stricture of, 240
- Excitability, alterations in, in disease, 208  
 of nerves and muscles. See Electrotonus
- Exhaustion, nervous. See Neurasthenia

- Exophthalmic goitre**, 281  
**External resistance**, 29, 67  
**Extra current**, 113  
**Extra-uterine pregnancy**, 256  
**Eyelashes, ingrowing**, 223
- F.
- Facial neuralgia**, 288  
   paralysis, 287  
   prognosis of, 218  
**Faraday's discoveries**, 109  
   law, 113, 169  
**Faradic anæsthesia**, 183  
   bath, 272  
   coil, 115  
   currents, uses of, in therapeutics, 270  
   electricity, 109, 270  
   electricity, compared with galvanic, 132  
   super- and sub - excitability, 208  
**Faradization, galvano-**, 276  
   general, 271  
   local, 270  
**Faure's secondary battery**, 135  
**Favus**, 397  
**Feigned diseases**, 220  
**Fergusson, Dr.**, 419  
**Ferromagnetic s**, 20  
**Fevers, body resistance in**, 189  
**Fishes, electric**, 148, 152  
**Fibroid tumours**, 243  
**Finsen light**, 369. See ultra violet light  
   apparatus, 374  
**Fluorescence**, 317, 342, 384, 401  
   of quinine in X-ray treatment, 389  
**Focus tube**, 333  
**Foreign bodies, localization of, by X rays**, 346  
**Fœtation, extra-uterine**, 256  
**Force, electromotive**, 28, 53  
**Franklinization, internal**, 296  
**Freund, Dr.**, 398  
**Frictional electricity**, 3  
**Frictions, electric**, 263
- G.
- Gaiffe's battery**, 43  
   electrical machine, 13, 332  
   D'Arsonval galvanometer, 89  
   interrupter, 329  
**Galactagogue effects**, 301  
**Galvanic and faradic currents, physical differences**, 132  
**Galvanic circuit**, 26  
   electricity, 22, 155, 264  
   interruptions, effects of, 156  
   super- and sub - excitability, 210  
**Galvanism, bactericidal action of**, 180  
   cataphoresis by means of, 179  
   general indications for, 268  
   in diagnosis, 210  
   in medicine, 267  
   in physiology, 155  
   in surgery, 221  
   trophic effects of, disputed, 180  
**Galvanization of the brain**, 165  
   central, 268  
   of the head, 268  
   subaural, 267  
**Galvano-cautery**, 306  
   faradization, 276  
   puncture, 254  
**Galvanometer**, 80  
   astatic, 83  
   calibration of, 86  
   D'Arsonval's, 89  
   Edelmann's, 88  
   for medical men, 86, 90  
   hot-wire, 91, 337, 412  
   in diagnosis, 90, 189, 268  
   portable, 90  
   reflecting, 84  
   shunts, 86  
   sine, 83  
   tangent, 83  
**Galvanoscope**, 86  
**Gastralgia**, 296  
**Gastroscope**, 312  
**Gautier, Dr., and Dr. Iarat**, 154, 274, 304, etc.  
**General faradization**, 271  
**Genito-urinary organs, diseases of the**, 298  
**Glands, enlarged**, 396  
**Glycosuria**, 294  
**Goitres**, 226  
   exophthalmic, 281  
**Görl's lamp**, 380  
**Gout**, 204  
**Graphite rheostat**, 99

- Gravity cell, 49  
 Greig, Dr. 398  
 Grenet cell, 39  
 Grotthuss and Clausius, theory of, 172  
 Grove's battery, 51  
 Gull, Sir William, on chorea, 280  
 Gustatory nerve, 165, 220
- H.
- Hæmorrhage in uterine diseases, 244  
 post-partum, 301  
 Hæmorrhoids, 240, 298, 417  
 Hairs, removal of, 223  
 Hairy moles, 223  
 Hand, as an electrode, 271  
 Head, galvanization of, 165, 269  
 Headache in neurasthenia, 261  
 Heart, tachycardia in Graves' disease, 282  
 Heat and electricity, 1  
 Heating effect of current, 26, 91, 306  
 Joule's law, 306  
 Hedley, Dr., researches, 273, 275  
 Hellesen battery, 45  
 Hemianæsthesia, 188  
 Hemiplegia, 283  
 Herman's views, 157  
 Herpes zoster, 303  
 Herschell, Dr., 295, 298  
 High-frequency currents, 404  
 use in therapeutics, 417  
 physiological effects of, 412  
 Holland, Dr., 393  
 Holtz machine, 11  
 Holznecht's instrument, 362  
 Horse-power, 32  
 Human body, resistance of, 186.  
 See Resistance  
 capacity of, 198  
 Hydrometer, 141  
 Hyperæsthesia, 218, 279  
 Hypochondriasis, 280  
 Hysteria, 279
- I.
- Ice, transparency of, 373, 381  
 Impotence, 300  
 Incandescent lamps, 76, 307  
 in parallel, 140  
 Incontinence of urine, 300
- Indican in urine, disappearance of, 279  
 Induction, 109  
 coil, 115, 320  
 medical, 119  
 oil, 404  
 laws of, 113  
 self-, 113  
 static, 12  
 Infantile paralysis, 284  
 Influence machines, 11  
 Injuries of nerves, 213, 287  
 Insanity, melancholia, 280  
 Insomnia, 280  
 Insulated Leclanché cell, 39  
 Insulating stool, 15, 259  
 Insulators, 11  
 Internal resistance, 28, 58, 68  
 Interossei, in writer's cramp, 283  
 Interpolar changes in electrolysis, 175  
 Interrupter, automatic, 118  
 Interrupters, 320  
 Contremoulins-Gaiffe, 328  
 Davidson, 321  
 Dawson Turner, 326  
 dipping, 321  
 jet, 322  
 Wehnelt, 323  
 Interruptions, effect of galvanic, 157  
 slow and quick, 119, 148  
 Interstitial electrolysis, 304  
 Involuntary muscles, 164, 182, 297  
 Ions, 168
- J.
- Jamieson, Dr. Allan, 398  
 Jar, Leyden, 9  
 oscillating discharge of, 404  
 Joint affections, 293  
 Joule's law, 306
- K.
- Katelectrotonus, 156  
 Kathodal contraction, 157, 160  
 Kathode, 156, 158, 261, 318, 338  
 Kations, 170  
 K.C.C. (kathodal closing contraction), 159  
 Kind of electricity, 1  
 Kohlrausch's bridge, 65

## L.

Labile method, 267  
 Lachrymal obstruction, 241  
 Lamps, incandescent, 76, 307, 140  
     batteries for, 76, 144, 308  
 Larat, Dr., and Dr. Gautier, 274, etc.  
 Laryngoscope, 308  
 Larynx, electrical applications to the, 279  
 Lateral sclerosis, 285  
 Law, of contraction, 164  
     Faraday's, 113  
     Joule's, 306  
     Lenz's, 113  
 Lead paralysis, 213, 287  
     poisoning, 274  
 Leclanché cell, 35  
     dry, 45  
     insulated, 39  
     of low resistance, 38  
 Leduc, rodent ulcer, 305  
 Lenz's law, 113  
 Lewis Jones, 225, 275, etc.  
 Leyden jar, 9  
     oscillating discharge of, 404  
 Light, Finsen, ultra-violet, 369 *et seq.*  
 Light, battery for the electric, 76, 144, 308  
 Lighting currents from a dynamo, 122, 125, 131, 330  
 Lines of force, 16  
 Lippmann's experiments, 152  
 Localization of foreign bodies, 346  
 Local faradization, 270  
 Locomotor ataxy, 286  
 London, E. S., on Radium, 384  
 Lortet and Genoud lamp, 376  
 Lumbago, 293  
 Lupus, 393  
     erythematous, 396

## M.

Machines, electrical, 11  
     influence, 11  
     magneto-electrical, 119  
 Mackenzie Davidson, 321, 346, 393  
 Macintyre, Dr. John, 395  
 Magnetic field, lines of force in the, 16

Magnetism, 15  
     resemblance of, to static electricity, 20  
 Magneto-electric machines, 119  
     D'Arsonval's, 121  
     D'Arsonval's, physiological effects of, 184  
     curves to represent the currents of, 121  
     current of, compared to galvanic currents, 134  
 Magnets, 17  
     poles of, 18  
     properties of, 20  
 Malignant tumours, 256, 387, 417  
 Mammary gland, stimulation of, 301  
 Matteuci's experiment, 151  
 Mayou, Dr., 399  
 McClure, Dr., on static applications, 263  
 Measurement of current-strength, 78  
 Melancholia, 280  
 Menorrhagia, 255  
 Metallic poisoning, resistance of body in, 189  
 Metals in air, contact series of, 23  
 Methods of measuring current-strength, 78  
 Metrorrhagia, 255  
 De Metz, Dr., 198  
 Microfarad, 199  
 Milk, secretion of, 301  
 Milliampère, 28  
 Milliampère meter, 90, 91, 337, 412  
 Miller, L., 380  
 Milne-Murray switch-board, 127  
     sound, 249, 250  
 Moles, 223  
 Morton, Dr., 12, 389  
 Motor, electro-, for static machines, 14, 260  
     points, 202  
     transformers, 124  
 Mr. Shelford Bidwell on the Hellesen cell, 45  
 Multiple arc arrangement, 72  
 Muscle, conductivity of, 190, 198  
     currents, 150  
     electrolysis of, 174, 176

Muscle, frogs', M. Weiss's re-  
searches, 176  
reaction of degeneration  
of, 212  
stimulation of, 155, 166,  
182, 185  
Muscular atrophy, 284  
rheumatism, 293  
Mycosis fungoides, 398  
Myoma uteri, 243

## N.

N rays, 386  
Nævi, cases suitable for treat-  
ment by electrolysis,  
224  
needles for, 225  
treated by electrolysis, 225  
Natural electric phenomena,  
148  
Needles for aneurism, 229  
electro-surgery, 221  
galvano-puncture, 252  
Neef's hammer, 117  
Negative pole, action of, 15,  
155, 226, 244, 268, 338  
Negative variation, 151  
Negatives for X rays, 362  
Nerves, conductivity of, 190,  
198  
currents in, 150  
excitability of, in tetany,  
282  
injuries of, 213, 287  
of special sense, 164  
reaction of degeneration  
of, 212  
sensory, 163, 219  
Nervous system, diseases of,  
278, 283  
Neuralgia, facial, 288, 400  
sciatica, 289, 418  
treatment of, 261, 268,  
277, 288, 399, 418  
uterine, 300  
Neurasthenia, treatment of,  
278  
Neuritis, alcoholic, treatment  
of, 287  
diagnosis of, 213  
reaction of degeneration in,  
213  
Nocturnal incontinence, 298  
Nodon valve, 132

Nutrition, trophic effects of  
electricity, 154, 180, 184, 185,  
258

## O.

Obstruction, 297  
Oerstedt's discovery, 78  
Ohm, 28  
Ohm's law, 30  
Optic nerve, 164, 185, 384  
atrophy of, 219, 384  
reactions to faradism, 185  
reactions to galvanism,  
165  
reactions to high potential  
electricity, 415  
reaction to radium, 384  
reactions to sinusoidal  
currents, 185  
Osmosis. See Cataphoresis  
Oudin's resonator, 407  
Ovarian pain, 300  
Ozone, physiological and thera-  
peutical effects of, 154

## P.

Pain, treatment of. See  
Neuralgia  
Parallel arrangement of cells,  
69  
Paralysis, agitans, 280  
facial, prognosis of, 218  
facial, treatment of, 287  
infantile, 284  
lead, 217, 273, 287  
of bladder, 298  
of bowel, 296  
pressure, 287  
spastic, 285  
treatment of, 277  
value of the reaction of  
degeneration in localiza-  
tion and prognosis, 218  
value of static sparks, 13,  
262  
Parasitic affections, 303, 398  
Partial reaction of degenera-  
tion, 215  
Pernicious anæmia, the resist-  
ance of the urine in a case of,  
193; of the blood, 197  
Persulphate of mercury bat-  
tery, 43  
Pflüger's law of contraction, 156

- Phenomena, electrical, Tesla and Elihu Thompson's, 404  
 natural electrical, 148  
 Photography, Röntgen, 361  
 Phthisis, pulmonary, diagnosis of, 356  
 treatment of, 417  
 Physical differences between galvanic and faradic currents, 132  
 Physics, electro-, 3  
 Physiological effects of electricity, 147  
 Physiological effects of D'Arsonval's sinusoidal currents, 184  
 of faradic electricity, 182  
 of galvanic currents, 156  
 of high - frequency electricity, 412  
 of radium, 384  
 of static electricity, 153  
 Physiology, electro-, 147  
 Plan of apparatus for the Apostoli treatment, 251  
 Plates of a galvanic cell, 22  
 Pleurisy, X-ray diagnosis, 356  
 Plug collector, 93  
 rheostat, 97  
 Plumbism, 274  
 Pneumonia, effect of, upon the resistance of the urine, 193  
 Polarization, 27  
 depolarizer, 34  
 in accumulators, 135  
 Poles, choice of, 155, 226, 244, 268, etc.  
 how to distinguish, 15, 251, 339  
 in Apostoli's treatment, 244  
 of a magnet, 18  
 Portable galvanic and faradic battery, 143  
 Port-wine mark, 224, 232, 399  
 Positive and negative poles.  
 See Poles  
 Positive variation, 151  
 Post-partum hæmorrhage, 300  
 Potential, 1, 23, 53  
 difference of, 6, 53, 23  
 electricity of high, 404  
 Pressure paralysis, 287  
 Primary coil, 110  
 Primary current, 113  
 electrolysis, 173  
 Prime conductor, 11  
 Progressive muscular atrophy, 284  
 Prolapsus ani, 298  
 Properties of a magnet, 20  
 Prostate, enlargement of, 237  
 Pruritus, 303  
 Psoriasis, 394
- Q.
- Qualitative changes, 213, 219  
 Quantitative changes, 206, 213, 219  
 Quantity of electricity, 29  
 Quinine in X-ray treatment, 380
- R.
- Radium radiations, 382  
 bactericidal effect, 383  
 physiological effect, 384  
 therapeutic effect, 388, 392, etc.  
 Radio-active elements, 382  
 -chromomètre, 360  
 Raynaud's disease, 275  
 Reaction of degeneration, 212  
 atypical, 216  
 causes of, 213  
 course of, 214  
 curves of muscular contraction in, 214  
 diagnostic value of, in localization and prognosis, 217  
 muscle in, 213  
 nerve in, 213  
 partial, 216  
 pathology of, 215  
 phenomena of, 212  
 progress of a case of, 214  
 varieties of, 216  
 Reactions, auditory, 165, 219, 291  
 Reactions of nerves and muscles, examination of, 200  
 Rectal electrodes, 297  
 Rectum, stricture of, 239  
 Reflecting galvanometer, 84  
 Reiniger's acid battery, 147  
 Relative transparency of bodies to X rays, 360  
 to Finsen light, 372

- Resistance, 58**  
 coils, 97  
 effect of temperature on, 62, 189  
 galvanometer unreliable in the measurement of, 65  
 influence of electrical discharges on, 60  
 influence of light on, 63  
 influence of molecular condition on, 59  
 internal and external, 58  
 laws of, 59  
 measurement of, 62  
 of batteries, 68  
 of cautery burner, 307  
 of electrodes, 103  
 of electrolytes, 60, 172  
 of lamps, 308  
 of the blood, 61, 197, 230  
 of the body in ascites and dropsical conditions, 190  
 of the body in fevers, 189  
 of the body in Graves' disease, 189  
 of the body in health, 188  
 of the body in hemianæsthesia, 188  
 of the body in hemiplegia, 188  
 of the body in metallic poisonings, 189  
 of the bones, 190  
 of the cerebro-spinal fluid, 198  
 of milk, 198  
 of the muscles, 198  
 of the nerves, 198  
 of the skin, 61, 188  
 of X-ray tubes, 335  
 of the urine in Bright's disease, 193, 195  
 of the urine in diabetes mellitus, 192  
 of the urine in health, 190  
 of the urine in health: its relation to the salts present, 192  
 of the urine in health: its relation to the specific gravity, 191  
 of the urine in pneumonia, 193  
 specific, 59  
 unit of, 29
- Reverser, current, 96**  
**Rheophores, 102**  
**Rheostats, 97**  
**Rheumatism, acute, chronic, 274, 293**  
**Rheumatoid arthritis, 275, 293**  
**Rhinoscope, 312**  
**Rocher, Dr. Boisseau du, on dilatation of stomach, 295**  
**Rock-salt, transparency of, 372**  
**Rodent ulcer, 305, 392**  
**Röntgen ray therapeutics and Finsen light, 371. See X rays**  
**Röntgen rays, 315**  
**Ruhmkorff's coil, 114, 147, 320**
- S.
- Sarcoma, 387**  
**Sciatica, 289**  
**Sclerosis, lateral, 285**  
**Screens, X-ray, 342**  
**Séances, duration and repetition of, 269**  
**Secondary batteries, 135**  
   capacity of, 142  
   charging, 138  
   curve of current-strength of, 137  
   estimation of degree of exhaustion of, 141  
   medical uses of, 142  
   regulation and care of, 141, 142  
**Secondary and primary coils, 112, 114**  
   currents of, compared, 134  
**Secondary electrolysis, 173**  
**Secretion of milk, 301**  
**Selenium, resistance of, affected by light, 63**  
**Self-induction of current, 113**  
**Self-treatment by patients, 270**  
**Sensory nerves, 164, 184, 186, 218**  
**Series arrangement of cells, 54**  
**Shenton's (Mr. W. H.) X-ray cases, 367**  
**Shunts, 86**  
**Sichel, Dr., 393**  
**Simple static phenomena, 4**  
   rheostat, 99  
**Sine galvanometer, 83**  
**Single-handed dial collector, 93**  
**Sinuses, 396**

- Sinusoidal baths, 272, 293  
 currents, 184  
 motors, 121, etc.
- Skiagraphy, 361
- Skin, diseases of, 301, 387  
 acne, 302, 308  
 actinomycosis, 304  
 alopecia areata, 302  
 anæsthesia, 279  
 chilblains, 302  
 eczema, 274, 302, 397  
 elephantiasis arabum, 303  
 favus, 308  
 herpes, 302  
 hyperæsthesia, 219, 279  
 lupus, 393  
   erythematosus, 396  
 parasitic affections of, 303  
 pruritus, 303  
 rodent ulcer, 305, 392  
 sycosis, 304, 398  
 urticaria, 302
- Skin, resistance of, 61, 188
- Sledge collector, 92
- Smee's cell, 34
- Somerville, Dr., 419
- Sparks, physiological effects of,  
 treatment by, 13, 262
- Spasm of the muscles, 277
- Spastic paralysis, 285
- Special senses, reactions of, 164,  
 220
- Specific resistance, 50
- Spermatorrhœa, 299
- Sphincter, relaxation of, 298
- Spinal cord, diseases of, 283
- Stabile method, 267
- Standard electrodes, 187
- Statical apparatus, 11, 258
- Static electricity, 3, 153, 331  
 electricity for X-ray work,  
 331
- Static induction, 12  
 physiological effects of, 153  
 treatment by, 260
- Stevenson, Dr., 3, 235, etc.
- Stenosis of cervix, 256
- Stereoscopic fluoroscope, 352
- Stomach, dilatation of, 295
- Stone, Dr., on resistance of  
 body, 189
- Strel lamp, 379
- Strength, current-, 66, 269
- Stricture of the Eustachian  
 tube, 240
- Stricture of the lachrymal  
 canal, 241  
 of the œsophagus, 241  
 of the rectum, 240  
 of the urethra, 234
- Subaural galvanization, 267
- Subinvolution, 301
- Sugar in the urine, disappear-  
 ance of, under treat-  
 ment, 296  
 effect of, on the resistance,  
 193
- Surgery, electro-, 221  
 general requisites for, 222
- Surgical uses of electricity, 221
- Switch-boards, 125, 131, 331
- Sycosis, 304, 395
- Sympathetic nerve, galvaniza-  
 tion of, 267
- T.
- Tabes dorsalis 286
- Tables: conductors and insu-  
 lators, 11  
 contact series of metals in  
 air, 23  
 electro-chemical series, 168  
 E. M. F. of cells, 54  
 English and metric  
 measures, 420  
 Finsen light, 372  
 relative opacity to X rays,  
 360  
 resistance of electrolytes,  
 60  
 resistances of the human  
 body, 190, 198  
 resistance of the various  
 urines, 190 *et seq.*
- Tangent galvanometer, 83
- Telegrapher's cramp, 283
- Temperature, effect of, on  
 resistance, 62
- Tesla phenomena and high-  
 frequency currents, 404  
 theories to explain im-  
 munity of body to, 415
- Tetanus, 158, 183, 214
- Tetany, 282
- Theory of Grothuss and  
 Clausius, 171
- Therapeutic uses of X rays, 387  
 of Finsen light, 392  
 of radium, 388, 392, 395



Therapeutics, electro-, 257  
 Tic douloureux, 288  
 Tinnitus aurium, 290, 419  
 Tonic effect of electricity, 263, 273, etc.  
 Torticollis, rheumatic, 280  
 Trachoma, 399  
 Transparency and opacity to ultra-violet light, 372  
 Transformer, 124, 132, 405  
 Traumatic paralysis, 210, 288  
 Treatment of neuralgia, 263, 268, 277, 288, 400, 419  
   of neurasthenia, 262, 274, 278  
 Trichiasis, 223  
 Trophic effects, 152, 180, 183, 258, 276  
 Tubes, X-ray, various, 334  
*et seq.*  
 Tumours, malignant, 256, 387, 418  
   treatment by X rays, radium, and high-frequency currents, 387, 417  
 Two fluid cells, 46

## U.

Ulcers, 398  
 Ultra-violet light, 369  
   comparison with X rays, 400  
   employment of, 374  
   nature of, 400  
   production, 369  
   recognition of, 370  
   therapeutics of, in cancer, rodent ulcer, lupus, etc., 392 *et seq.*  
   transparency and opacity to, 372  
 Unipolar action, 223, 267  
   application, 222  
 Units, electrical, 28  
 Unpolarizable electrodes, 149  
 Urethra, chronic inflammation of, 237  
   stricture of, 234  
 Urethroscope, 312  
 Urinary organs, diseases of, 298  
 Urine, resistance of, 193  
 Urticaria, 302

Uterine electrodes, Apostoli's, 251  
   pain, 300  
   tumours, 256  
 Uterus, Apostoli's claims, 243, etc.  
   criticisms on Apostoli's treatment, 247  
   dysmenorrhœa, 256  
   endometritis, 256  
   extra-uterine foetation, 256  
   fibroid tumours of, 245  
   galvano-puncture, 255  
   menorrhagia, 256  
   requisites for Apostoli's treatment, 249  
 U-tubes, 177

## V.

Vacuum tube, 334  
 Vaso-motor effects, 174, 182, 190  
 Vigouroux, Dr., 190, 280, 296, etc.  
 Volt, 28  
 Volta's contact law, 23  
 Voltaic cell, simple, 22  
 Voltmeter, 79  
 Voltolini's battery, 144  
 Voluntary muscles, 162, 182  
 Vomiting, 296

## W.

Walker, Dr. Norman, 398  
 Wallace, Dr., on the cystoscope, 309  
 Walsh, Dr. David, 392, 399, 418  
 Walsham, Hugh, 356, 381  
 Warts, 224, 402  
 Water, head of, analogous to E. M. F., 53  
   flow of, analogous to an electrical current, 66  
   rheostat, 99  
 Watteville, Dr. de, on electrotonus, 160  
   on galvano - faradization, 276  
 Watts, 32  
 Weiss, Mons., researches on cataphoresis, 179  
   researches on interpolar action, 176

- Williams, Dr. Chisholm, 417  
 Wimshurst's machine for X  
   rays, 11, 332  
   for high - frequency cur-  
   rents, 404  
 Wires. See Rheophores  
 Women, diseases of, 243  
 Writer's cramp, 282
- X.
- X rays, 315  
 production of, 318  
 tubes, 333, 339, 340  
 effects of, 341  
 fluorescent screens, 342,  
   367  
 diagnosis, phthisis, etc.,  
   356
- X-ray dermatitis, 402  
 X-rays, table of relative opacity  
   to, 360  
   compared with Finsen rays,  
   400  
   in photography, 361  
   measurement of penetrat-  
   ing power and of  
   quantity, 360, 361  
   therapeutics, cancer, sar-  
   coma, rodent ulcer, etc.,  
   387-400  
 Xeroderma pigmentosum, 398
- Z.
- Zero potential, 53  
 Zincs, how to amalgamate, 107

THE END

*London: Baillière, Tindall & Cox, 8, Henrietta Street, Covent Garden.*







422

**LIBRARY RULES**

**HOURS 11-12 A.M.**

practical  
tricity.

1. One book only will be issued on presentation of borrower's card.

2. Books may be retained for a period of four days. Renewal for four days more will be made upon request.

3. A fine of 5 cents per day will be charged on books not returned when due.

4. Borrowers will be charged for all injury to books.

**LIBRARIAN'S HOURS**

**MONDAY AND FRIDAY, 9-12 A.M.  
WEDNESDAY, 1-4 P.M.**

SCHOOL LIBRARY

