

## **An introduction to mathematical analysis.**

Griffin, Frank Loxley, 1881-1969  
Boston, Houghton Mifflin [c.1922]

<http://hdl.handle.net/2027/nyp.33433069104713>

# HathiTrust



[www.hathitrust.org](http://www.hathitrust.org)

**Public Domain, Google-digitized**

[http://www.hathitrust.org/access\\_use#pd-google](http://www.hathitrust.org/access_use#pd-google)

We have determined this work to be in the public domain, meaning that it is not subject to copyright. Users are free to copy, use, and redistribute the work in part or in whole. It is possible that current copyright holders, heirs or the estate of the authors of individual portions of the work, such as illustrations or photographs, assert copyrights over these portions. Depending on the nature of subsequent use that is made, additional rights may need to be obtained independently of anything we can address. The digital images and OCR of this work were produced by Google, Inc. (indicated by a watermark on each page in the PageTurner). Google requests that the images and OCR not be re-hosted, redistributed or used commercially. The images are provided for educational, scholarly, non-commercial purposes.

NYPL RESEARCH LIBRARIES



3 3433 06910471 3





3-ONE

Griffiths  
Original from  
NEW YORK PUBLIC LIBRARY











# AN INTRODUCTION TO MATHEMATICAL ANALYSIS

By

FRANK LOXLEY GRIFFIN, PH.D.

*Professor of Mathematics, Reed College, Portland, Oregon*



HOUGHTON MIFFLIN COMPANY

BOSTON NEW YORK CHICAGO SAN FRANCISCO

*The Riverside Press Cambridge*

1424



THE NEW YORK  
PUBLIC LIBRARY  
**404545A**  
ASTOR, LENOX AND  
TILDEN FOUNDATIONS  
R 1929 L

**COPYRIGHT, 1922, BY FRANK LOXLEY GRIFFIN**

**ALL RIGHTS RESERVED**

B 2

NEW YORK  
PUBLIC LIBRARY  
ASTOR, LENOX AND  
TILDEN FOUNDATIONS

**The Riverside Press**  
CAMBRIDGE • MASSACHUSETTS  
PRINTED IN THE U. S. A.

## PREFACE

UNDER the traditional plan of studying trigonometry, college algebra, analytic geometry, and calculus separately, a student can form no conception of the character and possibilities of modern mathematics, nor of the relations of its several branches as parts of a unified whole, until he has taken several successive courses. Nor can he, early enough, get the elementary working knowledge of mathematical analysis, *including integral calculus*, which is rapidly becoming indispensable for students of the natural and social sciences. Moreover, he must deal with complicated technique in each introductory course; and must study many topics apart from their uses in other subjects, thus missing their full significance and gaining little facility in drawing upon one subject for help in another.

To avoid these disadvantages of the separate-subject plan the unified course presented here has been evolved. This enables even those students who can take only one semester's work to get some idea of differential and integral calculus, trigonometry, and logarithms. And specialist students, as experience has shown, acquire an excellent command of mathematical tools by first getting a bird's-eye view of the field, and then proceeding to perfect their technique.

A regular course in calculus, following this, can proceed more rapidly than usual, include more advanced topics, and give a fine grasp: the principles and processes have become an old story. And the regular course in analytic geometry can be devoted to a genuine study of the geometrical properties of loci, since most of the type equations, basic formulas, and calculus methods are already familiar.



The materials presented here have been thoroughly tried out with the freshman classes in Reed College during the past nine years. Problems and methods which have proved unsatisfactory have been eliminated. Care has been taken to make the concepts tangible, relate them to the familiar ideas of daily life, exhibit practical applications, and develop the attitude of investigation. *E.g.*, in many "leading problems," — indicated in the text by bracketed numerals, — students are asked to formulate for themselves methods not yet discussed.

The order of topics while unusual, — especially in starting calculus before trigonometry, — is a natural one.

We begin with graphical methods because they afford a simple and interesting means of introducing the function-concept and the big central problems, — and also because they tend to develop at the very outset the self-reliant habit of attacking problems by "rough and ready" methods of approximation when no better methods are known.

Refining the graphical methods leads naturally to the calculus. After some work with this, the need for trigonometric functions is seen, and these are introduced. During the work on trigonometry, analytic geometry, etc., the continuity of the course is preserved by frequent problems which require calculus as well as these other subjects.

The intervals between the several parts of the calculus are thus a gain rather than a loss: they give the big principles a chance to emerge from the details. These principles are kept before the student during almost the entire year, notwithstanding the fact that systematic courses in trigonometry, analytic geometry, etc., are worked in.

There is, by the way, considerable analytics in the course besides what appears in Chapter VIII. (Cf. §§ 26–32, 40–41, 170–175, 244–247, 258, 268, 274–278, 296, 298, and the numerous plotting exercises in Chapters II–IV, VII, IX–XII.) But the idea of coördinates proper is not introduced until we are ready to use it in studying geometry. Up

to that point the *function-concept* is the thing: we are interested simply in the *varying height of the graph*, and do not need the more subtle conception of a *relation* between the coördinates of every point along a curve, — in other words, the idea of *implicit functions*.

The trigonometry also is continued for some time, — the analytical portion being treated late, when needed. The transition to the general definitions when we are ready to study periodic variations is made smoothly.\*

The natural difficulty in assimilating the many new ideas in the course is largely overcome by close correlation, and by the practice of assigning some review problem with advance work. This last, with frequent rapid oral quizzes reviewing recent studied material, enables us to work with each essential topic long enough to fix it clearly in mind, although proceeding rapidly. No effort is made to cover intricate points of technique or to discuss subtle niceties of logic. But we do insist upon clear ideas, grasp of the train of thought running through the course, and ability to use the processes accurately in simple cases.† Problem work in class is prominently featured.

Certain topics, *e.g.*, those treated in §§ 32, 72–73, 84, 101, 115–116, 118, 142–143, 151–154, 183, 219–221, 224, 241, 242, 281, 282, 284–286, 298–304, and Chapters XIV–XV, we have usually dealt with very briefly, — but sufficiently to make them clear at the time and enable the student to pick them up again easily if he needs them later on. Still other topics, such as those of §§ 82, 155–156, 228, 275–276, 318, 320–324,

\* There seems to be a widespread idea that by giving the general definitions of the functions at the outset all re-statements can be avoided. On the contrary, to adapt such definitions to the solution of triangles, re-statement in the form “(opposite side) ÷ (hypotenuse),” etc., is necessary, and the two statements must both be learned almost at the outset.

† Thus we introduce, for example, the easy “short method” of setting up integrals, — but only after the exact methods are familiar. And the relation of the various methods is constantly pointed out.

are merely touched upon in lectures for the sake of extending the student's horizon and developing his imagination.

These latter topics coming mainly near the ends of chapters are mentioned without appreciably reducing the time spent upon essentials. *E.g.*, students work investment problems, in part, while studying the rest of Chapter XIII.

Any of the more advanced topics can of course be omitted if desired, and attention focused on drill work, — for which an abundance of exercises is provided. Thus the presence of these topics in the text merely makes for flexibility.

The course as given at Reed College takes four hours a week through the year, the number of lessons devoted to the several chapters, when taken complete, having run about as follows: 14, 4, 14, 8, 11, 12, 11, 16, 5, 7, 10, 6, 6, 5, 4. A considerable shortening can be effected by omitting any of the chapters IX, XII–XV, or §§ 181–184, or any work on functions of functions, or many details in Chapter I.

The course is adapted to students of widely differing preparations. A knowledge of plane and solid geometry and of algebra through quadratics is the most suitable equipment; but a number of students who had had only two years of secondary mathematics have carried the course very well. On the other hand, students who have already taken trigonometry and college algebra find in the present course very little that merely duplicates their former work.

The problems of the course have been collected largely from scientific, technical, and business sources. I am indebted to Miss Maurine Laber and to Miss Edna V. Johnston, alumnæ of Reed College, for drawing most of the figures in Chapters I–V and VII–XIV, respectively. I am also under great obligation to Professors C. S. Atchison, J. G. Hardy, W. R. Longley, and W. A. Wilson for reading the galley proofs and making valuable suggestions.

F. L. GRIFFIN

## CONTENTS

	PAGE
A PRELIMINARY WORD TO STUDENTS . . . . .	1
CHAPTER I. FUNCTIONS AND GRAPHS . . . . .	3
Some fundamental problems of variation : rates, mean values, extremes, zero values, formulas, etc.	
CHAPTER II. SOME BASIC IDEAS ANALYZED . . . . .	58
Instantaneous rates, tangents, areas, etc., as limits.	
CHAPTER III. DIFFERENTIATION . . . . .	76
Derivatives of polynomials and $u^n$ . Rates, extremes, etc.	
CHAPTER IV. INTEGRATION . . . . .	126
$\int x^n dx$ . Area, volume, momentum, work, fluid pressure, falling bodies, etc.	
CHAPTER V. TRIGONOMETRIC FUNCTIONS . . . . .	156
Solution of right and oblique triangles. Applications.	
CHAPTER VI. LOGARITHMS . . . . .	189
Numerical calculations. Compound interest. Triangles.	
CHAPTER VII. LOGARITHMIC AND EXPONENTIAL FUNCTIONS . . . . .	236
Compound Interest Law. Logarithmic and semi-logarithmic graphs. Laws discovered. Differentiation and integration : $\log u$ , $e^u$ , $uv$ , $u/v$ .	
CHAPTER VIII. RECTANGULAR COÖRDINATES . . . . .	271
Mapping. Motion. <i>Analytic geometry</i> : line, circle, parabola, ellipse, hyperbola ; translation ; intersections.	

	PAGE
CHAPTER IX. SOLUTION OF EQUATIONS . . . . .	326
Quadratics: $b^2 - 4ac$ . Rational roots of higher equations. Horner's and Newton's methods.	
CHAPTER X. POLAR COÖRDINATES AND TRIGONOMETRIC FUNCTIONS . . . . .	243
Definitions. Radians. Periodic variations. Derivatives.	
CHAPTER XI. TRIGONOMETRIC ANALYSIS . . . . .	368
Basic identities. Equations. More calculus. Involute. Cycloid. <i>S.H.M.</i> Damped oscillations. Addition formulas. Sums and products, etc.	
CHAPTER XII. DEFINITE INTEGRALS . . . . .	392
Summation of "elements": length, surface of revolution, etc. Plotting a surface. Double integration. Partial derivatives. Simpson's rule.	
CHAPTER XIII. PROGRESSIONS AND SERIES . . . . .	415
<i>A.P.</i> and <i>G.P.</i> Investment theory. Maclaurin series. Calculation of functions. Binomial theorem.	
CHAPTER XIV. PERMUTATIONS, COMBINATIONS, AND PROBABILITY . . . . .	440
$P_{n,r}$ ; $C_{n,r}$ . Chance. Normal Probability Curve. Least squares.	
CHAPTER XV. COMPLEX NUMBER SYSTEM . . . . .	460
Definition. Geometric representation. Operations. Roots of unity. Application.	
RETROSPECT AND PROSPECT . . . . .	472
APPENDIX . . . . .	485
Proofs for reference. Formulas. Integrals. Numerical tables: roots, natural and common logarithms, trigo- nometric functions for radians or degrees.	
INDEX . . . . .	509



# AN INTRODUCTION TO MATHEMATICAL ANALYSIS

## A PRELIMINARY WORD TO STUDENTS

(I) “**What It is All About.**” In scientific work and in daily affairs, we frequently observe that some two things seem to be *related*, — that any change in the one produces some corresponding change in the other. Often it is important to ascertain *precisely how the one will change with the other*.

To illustrate: the speed of a locomotive depends in part on the amount of fuel consumed. Just how will the speed vary with the consumption of fuel? The blood-pressure in a healthy person is different at different ages. Just how should the pressure vary with the age? How should the price of corn vary with the size of the crop? Or the cost of a reservoir with the capacity? Or the speed of development of a photograph with the temperature of the developer? And so on.

Mathematical Analysis makes a systematic study of *different modes of variation*, discovers the exact relations between the varying quantities, and devises easy methods of making whatever calculations may be necessary. It has played a leading part in the wonderful modern development of the exact sciences and is being used more and more in other fields of study, — in the social sciences, in medicine, engineering, and business administration.

The subject is a large one, and could be studied for many years without exhausting it. But the introduction given by the present course will provide mathematical tools adequate

for many kinds of scientific work. Also, — what is desirable as a part of any liberal education, — it will give a clear general idea of the nature, power, and uses of modern mathematics.

(II) **Some Suggestions as to Methods of Study.** No subject can be mastered by merely *receiving instruction*. One must *study it actively* for himself. Try, therefore, to react on each new question, and to devise some “rough-and-ready” method of your own for dealing with it.

Before studying each new lesson think over the recent work. Recall it clearly. Then, after reading the assignment, set down briefly in your own words just what each new process is, what it does, and why it is valid. This will save you much time in working the exercises. Study with care the examples solved in the text, as they often cover elusive points.

Now and then run rapidly over in your mind an outline of the course to date, in order to see each topic in perspective. Re-read occasionally the “summaries” of preceding chapters.

Numerous principles and processes will be covered, and you may find it easy to forget them at first. But we shall return again and again to the most important ones, so that, with a little persistence, you can make them your own before the end of the course.

Practice quizzing yourself. That is, think of questions which might come up in class, and see whether you can answer them. If any point is not clear, make a note of it in some place reserved for the purpose, and ask about it or look it up soon. Note carefully the exact meaning of each new technical term that is introduced. Make free use of the index, pp. 509–512. In short, “get into the game,” *actively*.

Some effort may be required for a thorough mastery of the course, but the final achievement will be well worth it.

# CHAPTER I

## FUNCTIONS AND GRAPHS

### SOME FUNDAMENTAL PROBLEMS OF VARIATION

#### (A) THE PROBLEM OF EXHIBITING VARIATION

§ 1. **Graphs.** One of the best ways of showing how a quantity varies is by means of a *graph*.

What graphs are, and how widely they are used, will be clear from the following typical examples. You will doubtless recall having seen many others in your general reading.

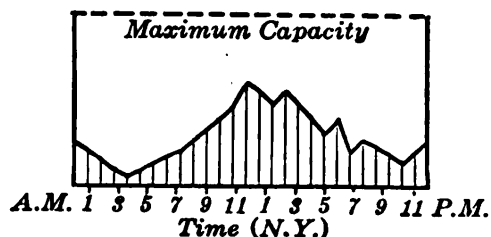

FIG. 1.

Fig. 1 is reproduced from an advertisement explaining low charges for transatlantic "cable letters" sent during certain hours. The height of the curve above the base line at any hour represents the rate at which messages are then being sent.

Where the curve is high, much business is being dispatched; where low, little business. The fluctuations from hour to hour are portrayed far more vividly than by a statistical table.

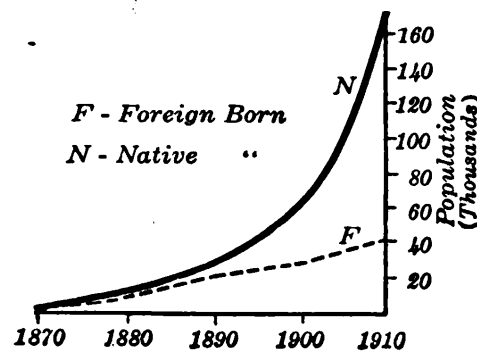

FIG. 2.

Fig. 2 exhibits the growth of the native and foreign born populations in Portland (Ore.) from 1870 to 1910. It shows at a glance not only the comparative sizes of the two populations at any time, as represented by the heights of the two curves, but also the comparative rates of increase, and a peculiar fluctuation in the rate of increase of the foreign-born.

Atmospheric pressure depends upon the elevation above sea-level. Fig. 3 shows how the pressure decreases as the elevation increases.

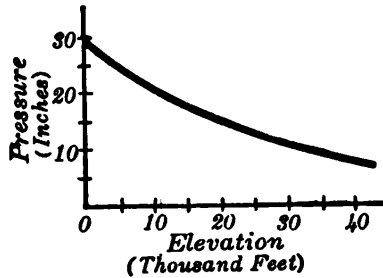

FIG. 3.

Besides showing how a quantity varies, — and calling attention to peculiarities, as in Fig. 2, — a graph is often helpful in *explaining some principle*, or in *studying some scientific law*. Figs. 4–6 illustrate this use of graphs.

Curves like those in Fig. 4 are used by economists to show how the laws of Supply and Demand together fix the selling price of a manufactured article, — *e.g.*, ice-cream. Curve *S* shows how the *supply* increases with the price: *i.e.*, its height at any point shows how much would be made to sell at the price there represented. Curve *D* shows the *demand*, — *i.e.*, the quantity that could be sold at each price. There is a price where demand equals supply: this is the natural selling price. (Why?)

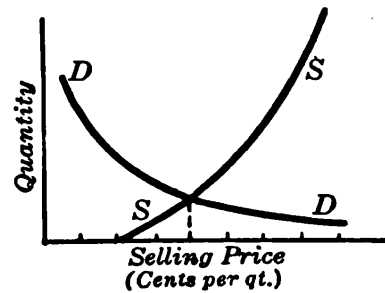

FIG. 4.

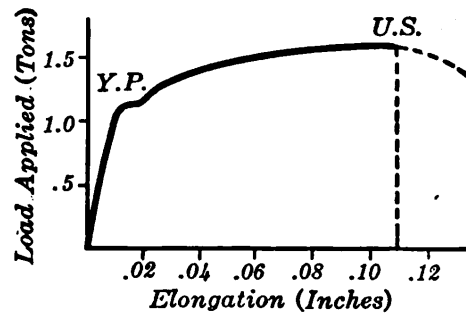

FIG. 5.

Fig. 5 is often used in showing how an iron rod acts under high tension, stretching at an almost constant rate until the “yield-point” is reached, then lengthening rapidly, — and breaking, if the point of “ultimate strength” is reached. The varying height shows how much tension is necessary to produce various elongations.

Diagrams like Fig. 6 are helpful in studying biological measurements. Here the height of each rectangle shows what percentage of soldiers in certain Scotch regiments had the chest measure indicated at the base of the rectangle. (*E.g.*, there were 18% whose measure was between 40 and 41 in.)

The height of the *curved* line shows the relative frequency with which any particular measure would be found in the long run. The fact that the curve is low toward either extreme means that

the chest-measure of very few men departs widely from the average. The same is true of many other physical measurements; and probably also of mental ability.

A third use of graphs, and the most important of all in practical work, is in making approximate calculations rapidly.

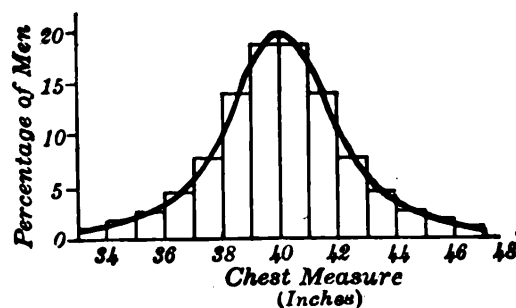

FIG. 6.

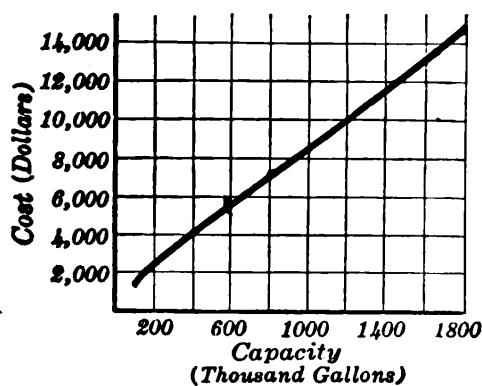

FIG. 7.

For example, a graph like Fig. 7 is used by a certain designer of large concrete oil-tanks. He can read off at a glance the approximate cost of a proposed tank of any desired size, and can submit a bid at once. The graph is a "ready-computer" which saves many hours of tedious calculations.

We shall see various other uses of graphs presently; but the basic principle underlying all of them is simply this:

*Points along the base line represent values of one quantity, while the varying height of the curve above the base line shows how some other quantity varies with the first.*

**§ 2. Function Defined.\*** Whenever one quantity,  $y$ , varies with another,  $x$ , in some definite way,  $y$  is called a *function* of  $x$ .

*E.g.*, the atmospheric pressure is a function of the elevation above sea-level; for the pressure varies with the elevation in some definite way, other things being equal.

Fig. 3, p. 4, shows *how* the pressure varies with the elevation, — in other words, shows *what sort* of function

\* The mathematical meaning of the word "function" is entirely different from the ordinary meaning. Be sure to get it clearly in mind.

the pressure is. Similarly Fig. 7 exhibits the cost of a tank as a function of the capacity. The primary use of graphs is to *exhibit some quantity ( $y$ ) as a function of some other quantity ( $x$ )*.

The quantity  $x$  upon which  $y$  depends is called the *Independent Variable*. It is regarded as running freely through its range of values represented along the horizontal scale, while  $y$  must vary with it in some definite way, as shown by the changing height of the graph.

**§ 3. How Graphs Are Drawn.** The process of drawing a graph will now be illustrated.

**EXAMPLE.** The amount of moisture, or weight of water vapor, that a cubic meter of air can hold depends upon the temperature. Table 1 shows the greatest amount possible at various temperatures from  $-20^{\circ}$  to  $+40^{\circ}$ , Centigrade. Plot a graph exhibiting the possible weight of vapor as a function of the temperature.

TABLE 1

TEMPERATURE (degrees)	WEIGHT (grams)	TEMPERATURE (degrees)	WEIGHT (grams)
-20	1.	15	12.8
-15	1.5	20	17.2
-10	2.3	25	22.9
- 5	3.4	30	30.1
0	4.9	35	39.3
5	6.8	40	50.9
10	9.3		

We first mark off on a horizontal line a series of points, equally spaced, and label them as in Fig. 8 to represent the temperatures shown in the table.

Now at  $40^{\circ}$  the weight is 50.9 gm. To show this we erect



at the  $40^{\circ}$  point a vertical line 50.9 units tall. (The unit may have any convenient size.) Similarly at the  $35^{\circ}$  point we erect a line 39.3 units tall; and represent likewise all other weights given in the table.

These vertical lines or “ordinates” show roughly how the weight of vapor varies with the temperature in saturated air. The variation is shown better when we join the ends of the ordi-

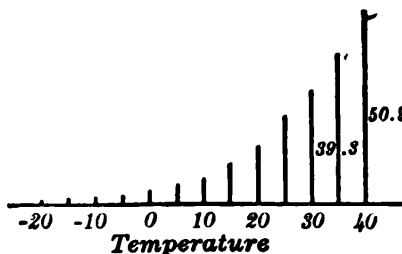

FIG. 8.

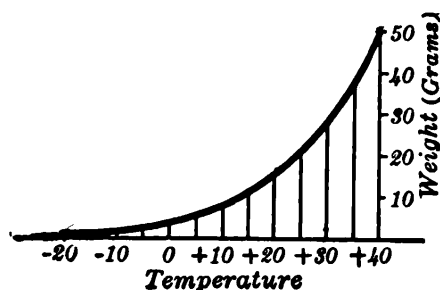

FIG. 9.

nates by a smooth curve, as in Fig. 9. This curve is the required graph.

If, at any point on the horizontal base line, representing any temperature from  $-20^{\circ}$  to  $40^{\circ}$ , we erect an ordinate, *its length up to the curve will represent the*

*maximum weight of vapor which 1 cubic meter of air can hold at that temperature.*

Indeed, one use for the graph is just this: to ascertain by measuring ordinates how much vapor can be held by air at *other temperatures* than those given in the table.

For accurate measurement we plot on a large scale and use “graph paper,” ruled in squares. (See Fig. 7, p. 5.)

**§ 4. Suggestions as to Details.** — Before plotting always mark off suitable scales of values along the base line and some vertical line. Let the horizontal scale invariably *increase toward the right* and the vertical scale *upward*. Never mind whether this makes the curve higher at the right or at the left. Run *negative values* toward the left or downward, respectively.

Make the graph *as smooth a curve as possible*: free from needless turns and abrupt changes of direction. Draw the

curve lightly until it appears satisfactory. A help toward smooth drawing is to turn the paper so that your hand is on the inner or concave side of the curve.

If you find a hump in the curve, due to a value which does not fit in smoothly with the other values, see whether you have plotted it correctly.

*Avoid drawing instruments*, such as ruler, compasses, and "French curves." To make the graph a series of straight lines with different inclinations in successive intervals would imply abrupt changes in the growth of the quantity, quite unlike the smooth and gradual changes produced by forces of nature.

*Exceptions:* In plotting statistics about the fluctuations of a quantity which we have no reason to suppose varies regularly, or where no meaning can be attached to ordinates erected between those given, we join the ends of the given ordinates by a series of straight lines. (Cf. Ex. 4 below.) The graph then merely "carries the eye." Also, if the ends of the ordinates happen to lie exactly in a straight line, we of course use a ruler, and make the graph as straight as possible.

In plotting a graph we use in reality only the *ends* of the ordinates. But it is desirable at first to draw the entire ordinates, as in Fig. 9, to fix in mind the important fact that the *varying height* is what we are really studying.

#### EXERCISES\*

1. (A) Plot carefully on graph paper the curve discussed in § 3, using 1 large space to represent  $10^\circ$  horizontally, 10 gm. vertically. (B) In your curve draw ordinates at temperatures of  $34^\circ$  and  $18^\circ$ , and note their lengths. What weights of vapor can be held at those

\* The most convenient paper is that having 10 small spaces to 1 large space. For rapid practice this is more important than great accuracy of ruling.

temperatures? (C) At what temperature will 1 cubic meter of saturated air contain 3 gm. of vapor?

2. Table 2 shows the standard atmospheric pressure in inches of mercury, at various elevations above sea-level. (A) Plot, using 1 large space for 5000 ft. horizontally, and for 5 in. vertically. (B) Find the pressure at the summit of Mt. McKinley, 20,464 ft. above sea-level. (C) How high is an airplane if the pressure shown by its barometer is 19.8 in.? (D) How much difference between the pressures at 10,000 and 20,000 ft.?

TABLE 2

ELEVATION	PRESSURE	ELEVATION	PRESSURE
0	30.0	24,000	11.8
6,000	23.8	30,000	9.5
12,000	19.0	36,000	7.5
18,000	15.0		

3. Table 3, used by life insurance companies, tells how many will be living at various ages, out of an average group of 100,000 persons at age 10. (A) Plot a graph showing the number of survivors as a function of the age attained. (Use 1 small space for 1 year horizontally and for 2000 persons vertically. Merely estimate odd hundreds in plotting.) (B) How many survivors at 35 years? By what age will half of the original company have died? (C) How many die between 45 and 55?

TABLE 3

AGE	LIVING	AGE	LIVING
10	100,000	70	38,569
20	92,637	75	26,237
30	85,441	80	14,474
40	78,106	85	5,485
50	69,804	90	847
60	57,917	95	3
65	49,341		

4. Exhibit graphically the world's yearly production of gold from 1872 to 1917. (In Table 4 the amounts are in millions of dollars.)

TABLE 4

YEAR	AMOUNT	YEAR	AMOUNT
1872	115.6	1897	236.1
1877	114.0	1902	296.7
1882	102.0	1907	413.0
1887	105.8	1912	466.1
1892	146.3	1917	419.4

5. Table 5 shows the number of kilograms equivalent to various numbers of pounds. Plot, using 1 space vertically for 2 kg., horizontally for 5 lb. (What sort of graph? Why?) Read off the equivalent of 28 lb.; of 1.44 kg.

TABLE 5

Lb.	Kg.
0	0
5	2.268
10	4.536
15	6.804
20	9.072
25	11.340
30	13.608

TABLE 6

A	P
25	19.90
30	22.70
35	26.30
40	31.00
45	37.40
50	46.20
55	58.30
60	75.00

TABLE 7

h	D
10	3.9
50	8.7
100	12.3
160	15.6
200	17.4
300	21.3
400	24.5

6. The annual premium ( $\$P$ ) which a certain life insurance company charges for a  $\$1000$  policy taken out at various ages ( $A$  yr.) is shown in Table 6. Plot, using 1 space for  $\$10$  vertically, for 10 yr. horizontally. Find  $P$  at age 32.

7. The distance ( $D$  mi.) of the horizon at sea varies with the height ( $h$  ft.) of the observer's eye above the water, as in Table 7. Plot  $D$  as a function of  $h$ , using scales of 5 mi. and 50 ft. How much farther can one see at a height of 360 ft. than at 80 ft.?

8. Find three graphs in the Encyclopædia Britannica, or other outside sources, and state what quantity each exhibits as a function of what other. [See Aberration, Bacteriology, Bridges, Climate, Heat, Influenza, Liquid Gases, Photography, etc.]

9. Which quantity would you plot vertically if given a table showing the speed of a train at various times? The time of swing for pendulums of different lengths? The cost of running a locomotive at different speeds?

10. To practice using the index, pp. 509–512, locate the pages on which the following are mentioned: “probable error,” “die-away curve,” “reciprocal.”

**§ 5. Interpolation.** The operation of finding a value of a variable quantity between those given in a table, and consistent with them, is called *interpolation*. One way to interpolate roughly is to plot a graph and read off the required intermediate values. This can be done rapidly if the scales are well chosen.

**§ 6. Choice of Scales.** The most convenient scales are those in which each space represents 1 unit, 10 units, or 100 units, etc. But if these would make the graph too large for the paper or too small for accurate interpolating, we let each space represent 2 or 20 units, etc., or  $\frac{1}{2}$ , 5, or 50 units, etc.

Scales based upon 3, 4, or anything worse should be avoided. Even if all the values in a table ran by 12's, we should employ scales of 10, or 20, etc., in order to read off readily any required intermediate values.

In short, the essentials are: (1) a convenient number of units to each space; (2) as large a graph as possible.

Always examine the table carefully at the outset with these aims in view. Also decide, before marking off the scales, which quantity is the *function* to be exhibited vertically. Turning the paper afterward would make one of the scales increase in the wrong direction.

## EXERCISES

1. The amount ( $\$A$ ) which a deposit of  $\$1000$  will yield after various intervals of time ( $T$  yr.), drawing interest at 6%, compounded annually, is shown approximately in Table 1. Plot  $A$  as a function of  $T$ . Find how much  $A$  will increase between  $T=18$  and  $T=33$ . When will the original sum have been quadrupled?
- ✓ 2. The number of years that an *average* person at any given age will live is the *expectancy* for that age. This is shown in Table 2 for various ages ( $A$  yr.) Plot  $E$  as a function of  $A$ . How much does a man's expectancy decrease between the ages of 12 and 32? When is  $E$  half as great as at age 20?

TABLE 1

$T$	$A$
0	1000
5	1338
10	1791
15	2397
20	3207
25	4292
30	5743
35	7686

TABLE 2

$A$	$E$
10	48.7
20	42.2
30	35.3
40	28.2
50	20.9
60	14.1
70	8.5
80	4.4

TABLE 3

$T$	$V$
0	75,000
10	70,000
20	55,000
30	30,000
40	13,000
50	6,000
60	3,000

TABLE 4

DATE	ERROR	DATE	ERROR
Jan. 1	- 5.0	July 18	- 8.0
Feb. 1	-14.5	Aug. 1	- 7.2
Feb. 12	-15.6	Sept. 1	- 0.9
Mar. 1	-13.3	Oct. 1	9.0
Apr. 1	- 5.0	Nov. 1	15.2
May 1	2.0	Dec. 1	10.2
May 12	3.5	Dec. 15	3.5
June 1	2.0	Dec. 31	- 4.5
July 1	- 4.5		

- ✓ [3.] The estimated value ( $V$ ) of a certain piece of property at various times ( $T$  yr. hence) is shown in Table 3. Plot, and find the probable value 25 yr. hence. How much will  $V$  decrease from  $T=5$  to  $T=10$ ? What is the average *rate* of decrease per year for those five years?

4. Table 4 shows the error of a certain sun-dial on various days of the year, negative signs indicating when the dial is slow. (A) Plot, treating months as equal, and drawing negative ordinates downward. (B) What error on April 10? (C) On what days, approximately, should the dial be correct?

5. The probable error ( $E$  meters) of the U. S. army range-finder at various ranges ( $R$  meters) is shown by Table 5. One of the values is given incorrectly. Plot, and find which one; also what the value should be.

6. Table 6 shows the number of days of illness during a year for an average person at various ages ( $A$  yr.). Plot. Find  $N$  for age 58. Also the increase in  $N$  between the ages of 72 and 82.

7. Table 7 shows the number of people killed in 4th of July celebrations in various years. Show this graphically.

TABLE 5

$R$	$E$
400	.7
1000	4.4
1500	9.7
2000	15.2
2500	27.0
2750	32.9
3000	39.0

TABLE 6

$A$	$N$
18	4.5
30	6.
40	8.3
55	19.
65	44.
75	105.5
83	171.5

TABLE 7

YEAR	DEAD	YEAR	DEAD
1903	466	1910	131
1904	183	1911	57
1905	182	1912	41
1906	158	1913	32
1907	164	1914	40
1908	163	1915	30
1909	215	1916	30

8. Make a table of squares for the numbers 0, 2, 4, 6, 8, 10. Plot a graph showing how the square varies with the number. Read off  $(7.6)^2$  and  $\sqrt{68}$ , and check.

### (B) THE RATE PROBLEM

§ 7. **The Idea of a Rate.** In studying a varying quantity or function we often need to know how fast it is increasing or decreasing, — in other words, the *rate* at which it is changing.

The general idea of a rate is, of course, *the amount of change in the function per unit change in the independent variable*. Graphically this is represented by the distance the graph of the function rises or falls per horizontal unit. Thus a rate is shown by the *steepness* of the graph, and not by the height at any point.

If the graph is a straight line, rising by a fixed amount in each and every horizontal unit, the function must be increasing at a constant rate.



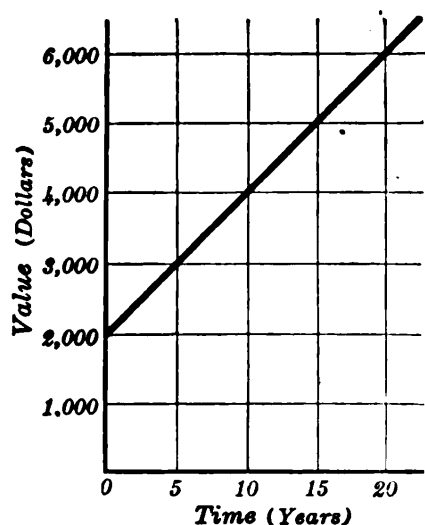

FIG. 10.

Thus in Fig. 10, representing the growing value of a certain investment, the value increases at the constant rate of \$200 per year. See also Fig. 5, p. 4.

Conversely, if the rate is constant, the graph must be straight, since it must rise by the same amount in every unit.

Most quantities, however, change at a varying rate. In such cases we distinguish between the *average rate of change* during some *interval*,

and the *instantaneous rate* at some particular *instant*.

For instance, if the volume of a balloon increased by 1200 cu. ft. in six hours, it increased at the average rate of 200 cu. ft. per hr. But it may have been increasing more or less rapidly than this at any particular instant, — or even decreasing part of the time.

The distinction, and the relation, between the two kinds of rates will be discussed more fully as we proceed. Both kinds can be found approximately from a graph.

**§ 8. Average Rates Found Graphically.** To find from a graph the average rate of increase of a varying quantity or function in any interval, we merely read off the *amount* of increase during the interval, and divide by the length of the interval or change in the independent variable. Similarly for a rate of decrease.

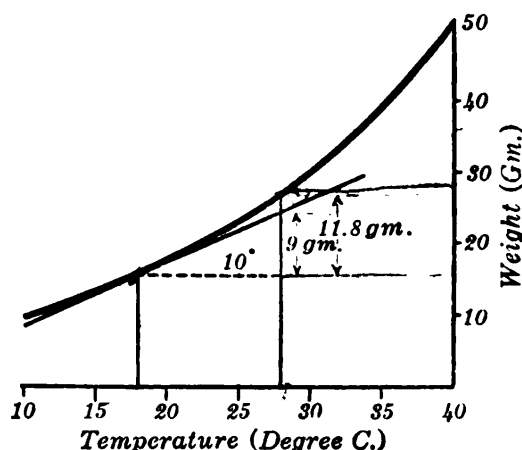

FIG. 11.

**EXAMPLE.** Find the average rate at which the weight of vapor in saturated air increases with the temperature between  $18^{\circ}$  and  $28^{\circ}$ .

The graph (Fig. 11) shows that the weight increases by 11.8 gm. during this  $10^\circ$  interval. Hence the average rate is 1.18 gm. per deg.

**§ 9. Instantaneous Rates Found Graphically.** A straight line tangent to a graph at any point will forever rise at the same rate as the graph was rising at the point of tangency.\*

Hence, when we wish to find how fast a given function was increasing at a certain *instant* or *point*, rather than its average rate of increase during some *interval*, we need merely draw a tangent to the graph at the point in question, and find the required instantaneous rate from it, using any convenient interval.

*E.g.*, from the tangent line (Fig. 11) we see that if the weight continued to increase at the same rate as at  $18^\circ$ , it would increase by 9 gm. while the temperature rose  $10^\circ$ . Hence the instantaneous rate at  $18^\circ$  is .9 gm. per deg.

To draw a tangent line accurately by the eye, however, requires great care. The ruler should have the direction of the curve at the point of tangency and should run along the curve closely in both directions near by.

In solving rate problems the respective increases should be clearly labeled on the graph, as in Fig. 11. Also the answer should name the *units*, — as grams per degree, etc.

Rate units are often written as fractions. Thus grams per degree is abbreviated *gm./deg.*, indicating that this rate is found by dividing some number of grams by some number of degrees.

**§ 10. Small Intervals.** It is sometimes necessary to find the average rate of increase of a quantity in an interval so very short that the amount of increase cannot be read from the graph with any accuracy.†

\* This intuitive conception will be justified logically in § 41.

† Do not confuse the *amount* of increase with the *rate*. A function may increase very *little* in a short interval and yet be increasing very *fast*, — just as a train may run only an inch in a small fraction of a second and yet be running at a very high speed.

In such a case we may reason as follows: The average rate for the short interval would be very nearly the same as the instantaneous rate at any instant during the interval, — just as the average speed of a train during a small fraction of a second would be nearly the same as the speed at any instant during that short time.

Hence we may approximate an average rate in any short interval by finding graphically the instantaneous rate, say at the middle of the interval.

### EXERCISES \*

1. Table 1 shows the number of bacteria in a culture,  $t$  hr. after first observing them. Plot. When had the number doubled? What was the average rate of increase from  $t = 2.5$  to  $t = 4.5$ ? How fast was  $N$  increasing at the instant  $t = 5.6$ ?

2. The temperature of an object ( $T^\circ$  Cent.) fell as in Table 2 after various intervals ( $t$  min.). Plot. What was the temperature at  $t = 3.2$ ? How fast was the object then cooling? When was the temperature  $65^\circ$ ?

TABLE 1

$t$	$N$	$t$	$N$
0	100	4	739
1	165	5	1220
2	272	6	2010
3	449	7	3310

3. Radium decomposes continually. Table 3 shows the quantity ( $Q$  mg.) remaining after  $T$  yr., if the initial quantity was 1 gm. How much will remain after 500 yr.? When will only half remain? What is the average rate of change of  $Q$  during the first 1000 years? What instantaneous rate at  $T = 1000$ ?

\* For further practice invent rate-problems using graphs already plotted.

TABLE 2

$t$	$T$
0	80
2	54.8
4	42.3
6	36.1
8	33
10	31.5
12	30.7

TABLE 3

$T$	$Q$
0	1000
1000	681
2000	463
3000	315
4000	214
5000	146
6000	99
7000	68

TABLE 4

$t$	$x$
0	0
1	17
2	128
3	405
4	896
5	1625
6	2592
7	3773
8	5120
9	6561

TABLE 5

$C$	$V$
1	12
2	17.6
4	25
6	31
8	36
10	40
12	43.4
15	47.6
18	51

4. Table 4 shows the distance ( $x$  ft.) which a boat had traveled  $t$  minutes after starting. Plot. How far did the boat go between  $t=3.5$  and  $t=8.5$ ? What was the average speed during those five minutes? What speed at  $t=4$ ?

TABLE 6

$t$	$A$		$t$	$A$	
	(Pre.)	(Obs.)		(Pre.)	(Obs.)
0	—	56.6	36	10.5	11.
4	49.1	44.3	40	8.3	9.2
8	42.	42.	44	6.0	6.5
12	35.4	33.6	48	4.3	4.2
16	29.7	30.2	52	2.9	3.1
20	24.5	24.2	56	1.8	1.8
24	20.1	22.1	60	.7	1.1
28	16.4	17.0	64	.2	.8
32	13.2	13.6	68	Healed	

TABLE 7

TIME	No.	TIME	No.
Oct.	65	Aug.	1293
Nov.	102	Sept.	1576
Dec.	129	Oct.	1843
		Nov.	1971
Jan.	176	Dec.	1944
Feb.	225		
Mar.	253	Jan.	1837
Apr.	320	Feb.	1710
May	424	Mar.	1562
June	722	Apr.	1376
July	996	May	1088

5. The speed of a locomotive ( $V$  mi./hr.) varied with the consumption of coal ( $C$  tons/hr.), as in Table 5. Plot  $V$  as a function of  $C$ . What  $V$  requires 3 tons hourly? How fast does  $V$  increase with  $C$ , at  $C=4$ ? What is the average rate of increase between  $C=7$  and  $C=7.1$ ?

6. With Dr. Carrel's method of treating deep wounds, the date of healing can be predicted accurately.\* Table 6 shows the predicted and the observed size ( $A$  sq. cm.) of a typical wound  $t$  days after the first treatment. Plot together the theoretical and observed curves of healing. Theoretically, at what rate should the wound have been healing when  $t=28$ ?

7. Table 7 gives the number of soldiers in the A. E. F. (in thousands) from October, 1917, to May, 1919. Show this graphically. At what average rate were the A. E. F. increasing between May and October, 1918? Decreasing between February and May, 1919?

§ 11. **Interpolation by Proportional Parts.** If the intervals between the values in a given table are small, we can calculate intermediate values approximately without plotting a graph. For we may regard the rate of increase as practically constant within a small interval.

Ex. I. Find from Table I the weight of vapor in saturated air at  $23^\circ$  C.

TABLE I

TEMP. $T^\circ$	WEIGHT $W$ gm.
5 { 20	17.2
25	22.9
	} 5.7

We simply have to find how much  $W$  will increase while  $T$  rises from  $20^\circ$  to  $23^\circ$ .

The  $5^\circ$  rise in  $T$  increases  $W$  by 5.7 gm.

$\therefore$  The  $3^\circ$  rise in  $T$  increases  $W$  by  $3/5$  of 5.7 gm. (=3.4 gm.)

Adding this increase to 17.2, the weight at  $20^\circ$ , gives 20.6 gm. as the weight at  $23^\circ$ . This is evidently a reasonable value.

\* See Journal of Experimental Medicine, v. 24, pp. 429-460.

Observe in Fig. 12 that if the graph were straight, this calculation would be strictly correct, as the increase in  $W$  between  $20^\circ$  and  $23^\circ$  (denoted by the Greek letter  $\Delta$ , "delta") would be exactly three fifths of the whole increase 5.7 gm.

To avoid blunders in more complicated cases we may set the calculation down in detail, as in the following example.

Ex. II. Table II gives the "reciprocals" of 4.42 and 4.43.\* Find the number whose reciprocal is .22591.

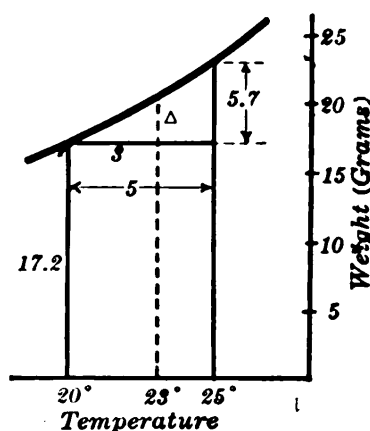

FIG. 12.

TABLE II

NUMBER ( $N$ )	RECIPROCAL ( $R$ )
.01 $\left\{ \begin{array}{l} \Delta \left\{ \begin{array}{l} 4.42 \\ \text{---} ? \\ 4.43 \end{array} \right. \end{array} \right.$	$\left. \begin{array}{l} .226244 \\ .225910 \\ .225734 \end{array} \right\} \left. \begin{array}{l} 334 \\ \\ \end{array} \right\} 510$

We first indicate the required value between the nearest given values, as shown here. Then we form *corresponding* differences in the two columns, using  $\Delta$  for *the difference between the required value of  $N$  and 4.42*.

For a constant rate of change, these corresponding differences should be proportional:

$$\frac{\Delta}{.01} = \frac{334}{510}$$

That is, the partial difference in  $N$  is to the whole difference in  $N$  as the partial difference in  $R$  is to the whole difference in  $R$ .

Multiplying through by .01 gives  $\Delta = 3.34 \div 510 = .0065$ .

Recalling what  $\Delta$  stands for, we add it to 4.42, getting 4.4265.

\* For a definition of "reciprocal," see § 30.

This result is reasonable, being between 4.42 and 4.43 and nearer the latter, — as it evidently should be from a comparison of the given values.

*Remarks.* (I) If we had used  $\Delta$  to denote the difference between the larger value (4.43) and the required value, we should have *subtracted* the value of  $\Delta$  finally from 4.43.

(II) How inaccurate the results obtained by this method of “Proportional Parts” are, depends on how much the graph would deviate from a straight line in the interval considered. In general, *it is a waste of time to calculate the value of  $\Delta$  to many figures.*

### EXERCISES

(To be worked by Proportional Parts)

- In Ex. II, solved above, show that if  $\Delta$  were used to denote the difference between the required value and 4.43, the final result would be the same although the value of  $\Delta$  came out differently.
- If 1 cu. M. of saturated air contains 10 grams of vapor, what is its temperature? (See Table 1, p. 6.)
- How many “survivors” will there be at 43 years? (Table 3, p. 9.)
- What is the pressure at 4000 ft. elevation? (Table 2, p. 9.)
- In how many years at 6% compound interest will any original principal double itself? (Table 1, p. 12.)
- (A) Draw a rough sketch similar to Fig. 12, to illustrate Ex. 2.  
(B) The same for Ex. 3.

TABLE 1		TABLE 2		TABLE 3		TABLE 4		TABLE 5	
$P$	$T$	$T$	$D$	$N$	$S$	$N$	$R$	$v$	$p$
760	100	26	13.532	890	792,100	1.40	.7143	1200	.94
787.7	101	28	13.528	891	793,881	1.41	.7092	1500	1.06
816	102	30	13.523	892	795,664	1.42	.7042	1800	1.15
845	103							2100	1.15
								2400	1.07
								2700	.94
								3000	.75
								3300	.51
								3600	.31

7. Table 1 gives the boiling point of water ( $T^\circ$ ) at various pressures ( $P$  mm.). Find  $T$  when  $P=800$ . Also  $P$  when  $T=102.8$ .



8. Table 2 gives the density of mercury ( $D$  gm. per cc.) at various temperatures ( $T^\circ$ ). Find  $D$  when  $T=27.2$ ; also  $T$  when  $D=13.526$ .

9. Table 3 gives the squares of 3 numbers. From it find approximately the square of 891.7. Check.

10. Table 4 shows the reciprocals of 3 numbers. Find the reciprocal of 1.418.

11. In running a waterwheel the power obtained ( $p$  horsepower) varied with the velocity ( $v$  revolutions per min.) as in Table 5. Find graphically: (A) The value of  $p$  at  $v=2500$ . (B) How fast  $p$  decreases at  $v=3000$ . (C) What velocity yields the maximum power. How much power? Check (A) by Proportional Parts.

§ 12. Tables of Squares, etc. To save time in many of the problems which follow, tables of squares and square roots, etc., are given in the Appendix, pp. 500–501.\* Some sample lines are shown here in part.

$N$	$N^2$	$\sqrt{N}$	$\sqrt{10N}$
5.0	25.00	2.2361	7.0711
5.1	26.01	2.2583	7.1414

This means, for instance, that

$$5.1^2 = 26.01; \quad \sqrt{5.1} = 2.2583; \quad \sqrt{51} = 7.1414, \text{ etc.}$$

The numbers  $N$  given in the table all lie between 1 and 10. But the table can be used for larger or smaller values because of these facts:

(A) Moving the decimal point one place in a number will merely move it two places in the square.

(B) Moving the point two places in a number will merely move it one place in the square root.

Ex. I  
 Since  $5.1^2 = 26.01$   
 hence  $51^2 = 2601$   
 also  $.051^2 = .002601$   
 etc.

Ex. II  
 Since  $\sqrt{5.1} = 2.2583$   
 hence  $\sqrt{510} = 22.583$   
 also  $\sqrt{.051} = .22583$   
 etc.

\* More extensive tables of like character are included in the Macmillan Logarithmic and Trigonometric Tables.

The column  $\sqrt{10N}$  gives the square root when the decimal point has been moved *one* place, or 3 places, etc. But in looking up a square root, the best way is not to think of “ $N$ ” and “ $10N$ ,” but to decide in advance what the first figure of the required root will be, and then look in the column where that figure occurs.

If you were going to extract the root without a table, the first step would be to point off “periods” of two places each, starting from the decimal point: the required first figure is found by extracting the square root of the leading period.

#### *Illustrations*

$\sqrt{5'10'00'00.}$	starts with 2; has 4 digits before the decimal point.
$\sqrt{51'00.}$	starts with 7; has 2 digits before the decimal point.
$\sqrt{.00'05'13'4(0)}$	starts with 2; in the second decimal place.
$\sqrt{.00'00'51}$	starts with 7; in the third decimal place.

In each case it is obvious which column of the table will give the required root: the correct leading figure occurs in only one!

Cube-root tables are used similarly; but the “periods” consist of three figures each. For illustrations see p. 501, Note (I).

Interpolation can be resorted to, when  $N$  has several significant figures.

#### EXERCISES

1. Look up the squares of 4.7; 680; 25000; .72; .019. Try to test each result roughly by common sense.
2. Look up the square roots of 3.3; 5600; 4200000; .028; .96. Check by common sense.
3. Look up the cube roots of 5.2; 870; 43000; .38.
4. (A) Look up the square and square root of 87.5, interpolating to take account of the third given figure. (B) The same for the number .198. (C) The same for .000629.
5. Table 1 is taken from a table of “logarithms.” Find  $\log N$  when  $N = 49056$ . Also  $N$  when  $\log N = 69060$ .

TABLE 1

$N$	49040	49050	49060
$\log N$	69055	69064	69073

6. Table 2 is from a table of "sines." Find  $\sin A$  when  $A = 12^\circ 35'.3$ .

TABLE 2

$A$	$12^\circ 35'$	$12^\circ 36'$
$\sin A$	.21786	.21814

7. Table 3 shows the temperature ( $T^\circ$ ) at several hours on a certain day. About when was  $T = 0$ ?

TABLE 3

$H$	8	10	12	2
$T$	-6	-2	6	9

8. For a cylindrical tank of a certain type and capacity, the cost ( $\$C$ ) depends upon the relation of the diameter and height, — varying with the diameter ( $D$  ft.), as in Table 4. Plot, using 1 large space

TABLE 4

$D$	$C$
80	8550
100	7200
120	6650
140	6600
160	6850
180	7250
200	7800

TABLE 5

$t$	$V$
0	0
10	90
20	320
30	630
40	960
50	1250
60	1440

vertically for \$500, and starting with \$5000 at the base line. Find the lowest possible cost, and what diameter gives it. How fast does  $C$  increase with  $D$  per foot at  $D=150$ ?

9. Table 5 shows the speed ( $V$  ft./min.) of a boat at various times ( $t$  min.) after starting. Find  $V$  when  $t=22$ , graphically and by Proportional Parts. Also find the acceleration when  $t=30$ . [Acceleration is the rate at which the speed is changing.]

[10.] In Ex. 9 can you devise some way to find the *distance traveled* from  $t=0$  to  $t=60$ ? (Hint: About what speed did the boat average during each 10 min.?)

### (C) THE MEAN-VALUE PROBLEM

§ 13. **Average Value of a Varying Quantity.** It is often necessary to find the average value of a quantity which is continually changing,—not the average of its values at a certain few instants, but the average value maintained throughout some interval of time.

If the varying quantity in question is the height of a graph, the problem is simply to find the average height in a specified interval or strip.

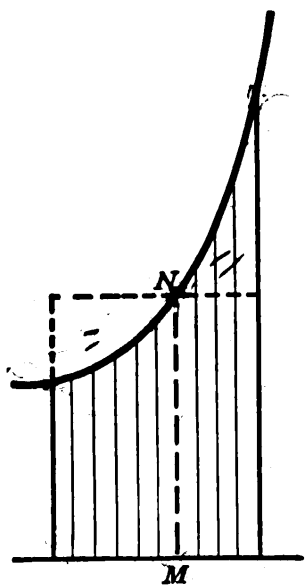

FIG. 13.

This is usually not the same as the average of the heights at the beginning and end of the interval. For the latter average takes no account of the way the height varies within the interval,—whether the curve sags or arches upward. Nor would the height at the middle of the interval in general be the required average height.

By the average height throughout an interval we mean simply: *The height which, multiplied by the base, would give the area under the curve in that interval.*

In other words, it is the height of a rectangle equivalent to the area under the curve and having the same base. (See  $MN$  in Fig. 13.)

The average height as thus defined is called the *mean*

*ordinate* of the curve in the strip considered. To approximate it closely, simply draw a horizontal line across the strip at about the right height, compare the triangular areas thus formed (to the right and left of  $N$ ), and move the line up or down if either area appears to be the larger.

That this definition of average height is a suitable one will be seen from the following applications.

**§ 14. Distance Found from a Speed-time Graph.** Suppose that we have a graph, such as Fig. 14, showing how the speed of a moving object varied, and that we wish to find the *distance traveled* during some interval of time. The problem is simply to find the *average speed*; for multiplying this by the time would give the distance.

The varying speed is represented by the varying height of the graph. Hence the average speed will be represented by the *average height*, — provided the latter is properly defined. That the definition in § 13 meets this requirement is easily proved.

**PROOF.** Suppose the dotted line  $BC$  (Fig. 14) drawn at the exact height  $AB$  which represents the average speed during the time  $AD$ . Then  $AB \times AD$  represents the product of the average speed by the time. That is, *the area of rectangle  $ABCD$  represents the distance traveled during the interval.*

Again, if  $AD$  were divided up into a billion smaller intervals, the sum of the rectangular areas likewise formed for these tiny intervals would still represent the distance traveled in the whole interval  $AD$ . But these rectangles would be so narrow and their successive heights differ by so little that they would virtually coincide with the area under the curve. Hence, — very approximately at least, — *the area under the curve also represents the distance traveled.* (That this representation is exact is proved in § 99, footnote.)

Therefore, since rectangle  $ABCD$  represents the same thing as the area under the curve in this strip, it must be equivalent to the strip, and its height  $AB$  must be the mean ordinate of the curve. *I.e.*, the average speed during the time  $AD$  is represented by the mean ordinate, as defined in § 13 (*Q. E. D.*).

Hence in Fig. 14 the average speed during this interval  $AD$  was, according to the vertical scale, about 140 ft./min.,

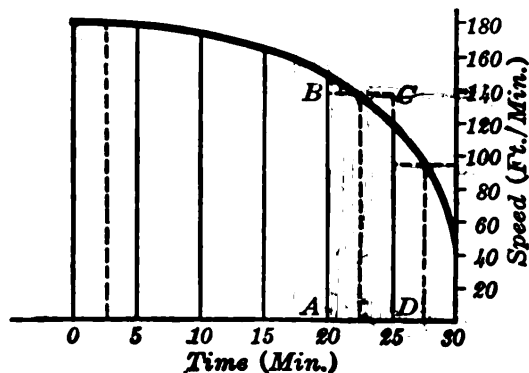

FIG. 14.

and the distance traveled during this 5 min. was about  $140 \times 5$ , or 700 feet. Similarly the average speed during the last 5 min. was about 94 ft./min. and the distance about 470 ft.

In finding the total distance traveled during several 5-min. intervals, time

would be saved by adding all the average speeds, as read off from the mean ordinates, and multiplying the sum by 5 instead of multiplying each separately.

A rapid rise or fall of a graph may necessitate using very narrow strips in some part of the curve.

### § 15. Further Physical Uses of Mean Ordinates.

(A) *Finding Momentum from a Force-time Graph.* A force acting upon an object imparts "momentum" to it. The amount of momentum equals the average force, multiplied by the length of time. *E.g.*, an average force of 35 lb. acting for 10 sec. imparts 350 lb.-sec. of momentum. But if the force is continually changing, how shall we know its average value?

Suppose the force plotted as a function of the time, — *i.e.*, represented by the varying height of a graph. Then the average force in any interval is represented by the corresponding average height or mean ordinate.

This can be proved in detail by reasoning just as in § 13 and showing that the areas of the rectangle and strip considered both represent the momentum imparted.

Using reasonably short intervals, we can estimate pretty accurately the average force in each; and can find the momentum.

(B) *Finding Work from a Force-distance Graph.* The amount of work done in moving an object is found by multiplying the distance the object travels by the average force used in moving it. *E.g.*, an average force of 35 lb., moving an object 10 ft., does 350 ft.-lb. of work.

If the force varies, and we have a graph exhibiting it as a function of the distance, the average force during any distance will be represented by the average height or mean ordinate of the curve. Hence the work can be found.

*Remark.* There are many more cases in scientific work in which mean ordinates are useful, — in fact whenever the area under the graph has a meaning. This will be so whenever the product of the two quantities represented horizontally and vertically has one. *E.g.*, in § 14, speed  $\times$  time = distance; etc.

### EXERCISES

1. The speed of an airplane ( $V$  ft./min.) after passing a certain point varied with the time ( $T$  min.), as in Table 1. Plot, and find the distance traveled during the hour covered by the table. How fast was the speed changing at  $T = 30$ ?

$T$	$V$
0	6080
10	6250
20	6120
30	5810
40	5440
50	5130
60	5000

$t$	$v$
0	0
.002	379
.004	700
.006	915
.008	990
.010	915
.012	700
.014	379
.016	0

$t$	$v$
0	1700
10	1575
20	1507
30	1507
40	1575
50	1700

2. As an auto traveled at a certain fixed speed, a point  $P$  on a tire traveled with a varying speed ( $v$  ft./min.), shown in Table 2 at various intervals of time ( $t$  min.) during one revolution. Find graphically the speed of  $P$  at  $t = .001$ . Check by Proportional Parts. (Why a discrepancy?) Find also the length of the path traveled by  $P$  during a turn.

3. If a projectile were fired with an initial speed of 1700 ft./sec. at an elevation angle of  $28^\circ$ , and there were no air resistance, its speed ( $v$  ft./sec.) would vary with the time ( $t$  sec.), as in Table 3. Plot and find the length of the path traveled during the 50 sec.

4. The speed of a vertically falling body increases during each second by 32.2 ft./sec. If thrown down with initial speed of 20 ft./sec., what speed has it after 1, 2, 3, 4, 5 sec.? Find graphically the total distance fallen from  $t = 0$  to  $t = 5$ .

5. Table 4 shows the speed of Halley's Comet ( $V$  million mi./yr.) at various times ( $T$  yrs.), since it was nearest the sun. (A) Find the distance traveled until farthest away: 38.5 yrs. (B) Find how fast the speed was changing at  $T = 6$ .

TABLE 4

$T$	0	1	3	6	9	12	15	21	30	38.5
$V$	1000	375	225	155	120	90	72	50	28	16

6. (a) Prove in detail that the area under a force-time graph represents the momentum imparted, and hence that the mean ordinate represents the true average force. (Use the idea of numerous tiny rectangles, as in § 14.) (b) What meaning has the area under a force-distance graph?

7. The pull exerted by a locomotive in starting a train exceeded the resisting forces by  $F$  tons, varying with the time elapsed ( $t$  sec.), as shown in Table 5. Find the total momentum given to the train in 8 seconds. Also the rate of increase of  $F$  at  $t = 1$ .

8. A weighing spring was stretched from a length of 6 inches to a length of 6.8 inches, the pull used ( $f$  lb.) increasing with the length ( $L$  in.), as in Table 6. Find the total work done in stretching the spring.

9. The resistance ( $R$  lb.) offered by a tug-of-war team after being pulled  $x$  ft. decreased as in Table 7. Find the total work done in pulling the team 48 ft.



10. The force ( $f$  lb.) exerted by steam upon a piston varied with the distance from one end of the cylinder ( $d$  ft.), as in Table 8. Find the work done in moving the piston from  $d = 1.3$  to  $d = 3.2$ .

11. Table 9 shows the intensity ( $i$  amperes) of an electrical current  $t$  sec. after the circuit was closed. Find the rate of increase of  $i$  at  $t = .002$ ; also the quantity of electricity passed in the first .005 sec. (The quantity,  $Q$  coulombs, equals the average intensity  $\times$  the time.)

12. The electrical power ( $P$  kilowatts) used by a factory during a half-day varied with the time ( $T$  hr.), as in Table 10. Find the total amount of energy used. (The energy,  $E$  kilowatt-hours, equals the average power  $\times$  the time.)

TABLE 5		TABLE 6		TABLE 7		TABLE 8		TABLE 9		TABLE 10	
$t$	$F$	$L$	$f$	$x$	$R$	$d$	$f$	$t$	$i$	$T$	$P$
0	0	6.0	0	0	1400	1.0	18400	0	0	0	250
1	26	6.1	5	9	1280	1.5	10250	.001	49.6	.5	500
2	40	6.2	10	18	1030	2.0	7300	.002	71.8	1.0	650
3	37	6.3	15	24	810	2.5	5400	.003	81.8	1.5	700
4	30	6.4	20	30	600	3.0	4250	.004	86.3	3.5	
5	21	6.5	25	36	410	3.5	3450	.005	88.4	3.8	690
6	11	6.6	30	42	280	4.0	2900	.006	89.3	4.0	650
7	4	6.7	35	48	200			.007	89.6		
8	1	6.8	40								

### § 16. Geometrical Uses of Mean Ordinates.

(A) To find the area within any closed plane curve divide the figure into narrow strips by parallel lines, and approximate each strip by a rectangle.

In this way, if the curve in Fig. 15 were a "contour line" running around a hill at some given elevation, as determined by a survey, we could find the area of the horizontal cross-section of the hill inclosed by that contour line.

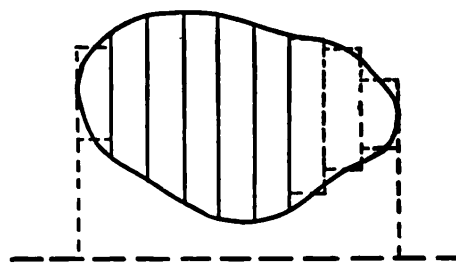

FIG. 15.

Engineers often use a "planimeter," which will measure

any small plane area approximately, however irregular the boundary.

(B) To find the volume of an irregular solid, say a hill,

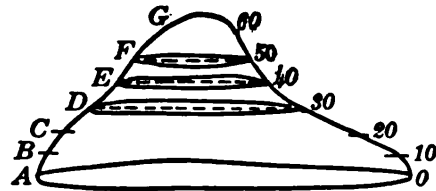

FIG. 16.

imagine it cut into thin slices by parallel planes, and approximate each slice by a cylinder. Any slice, such as  $DE$  in Fig. 16, equals a cylinder of the same height whose base area is some average cross-section area within the slice.

The areas of the various horizontal cross-sections  $A, B, C$ , etc., can be found as in Fig. 15 above. Suppose this done, and that we then plot a graph showing how the sectional area varies with the elevation. (Fig. 17.) The average height of the graph in any strip will represent the average area in the corresponding slice of the mound. If this is, say, 20,000 sq. ft. for the slice  $DE$ , whose thickness is 10 ft., the volume of the slice is 200,000 cu. ft. Similarly for the other slices.

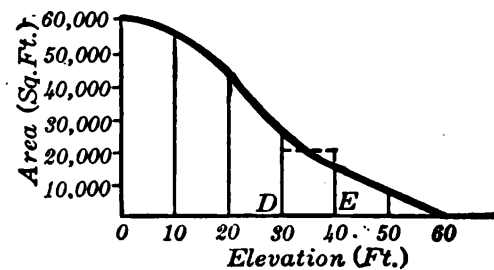

FIG. 17.

Reasoning as in § 14, we can show that the usual method of finding a mean ordinate is valid here; and that the area under the graph in Fig. 17 represents the *volume* of the hill. That is, on the chosen scales, the number of square units under the graph equals the number of cubic units in the hill.

### EXERCISES

1. A piece of land lies between a straight fence and a curved stream. Table 1 shows the distance from the fence to the stream ( $y$  yds.) at various points ( $x$  yds.) from one end of the fence. Map the land roughly and find its approximate area.
2. A ship's deck has an axis of symmetry running lengthwise. The semi-widths ( $w$  ft.) measured from this axis to one side of the deck

vary with the distance from the bow ( $d$  ft.), as in Table 2. Find the approximate area of the deck.

3. The depth ( $D$  ft.) for a proposed railway "cut" for a level track through a hill will vary with the distance ( $x$  ft.) from one end, as in Table 3. Assuming the hill to slope smoothly, find the average depth for each 100 ft. How much earth must be removed for a cut 20 ft. wide with vertical sides?

4. The area ( $A$  sq. ft.) of a horizontal section of a certain mound varies with the elevation ( $E$  ft.) above the base, as in Table 4. Find the volume of the mound, and also the rate at which  $A$  changes with  $E$  at  $E = 20$ .

5. A plumb-bob is to be made with its horizontal cross-section area ( $A$  sq. cm.) varying with the distance ( $x$  cm.) above the lowest point, as shown in Table 5. What will its volume be?

6. According to a naval architect's drawings, the horizontal sections of a certain ship at various heights ( $h$  ft.) above the keel will have the areas ( $A$  sq. ft.) shown in Table 6. What will the volume of the ship be, up to a height of 30 ft.?

TABLE 1		TABLE 2		TABLE 3		TABLE 4		TABLE 5		TABLE 6	
$x$	$y$	$d$	$w$	$x$	$D$	$E$	$A$	$x$	$A$	$h$	$A$
0	0	0	0	0	0	0	82100	0	0	0	0
10	32	50	15	100	7	5	75000	2	4.8	5	10900
20	49	100	24	200	20	10	67000	4	16.	10	15000
30	54	150	27	300	25	15	58000	6	28.8	15	15900
40	50	—		400	18	20	47400	8	38.4	20	16000
50	40	—	500	12	25	33500	10	40.	25		
60	27	—	600	17	30	0	12	28.8	30	15900	
70	14	350	700	12			14	0	35		
80	4	400	25	800	0						
90	0	445	12								
		450	0.								

7. Can you suggest some way to find from the graph in Ex. 3, p. 9, the average age attained by the 100,000 persons considered? (If a horizontal line be drawn to the curve from any point on the vertical scale at the left, what will it represent?)

[8.] An uncovered rectangular tank is to have a square base and contain 400 cu. ft. Materials for the base cost 30¢ per sq. ft., and for

the sides 20¢ per sq. ft. Can you suggest some way to figure out about what dimensions would give the lowest cost?

### (D) THE EXTREME-VALUE PROBLEM

#### § 17. Maximum and Minimum Values: Trial Method.

It is sometimes important to know the largest or smallest value of a variable quantity, — *e.g.*, the maximum power of a motor for all different speeds, or the minimum cost of a reservoir for different shapes.

Such “extreme values” can be found approximately by *experimenting repeatedly and comparing results*. A graph is often helpful in locating the highest and lowest values.

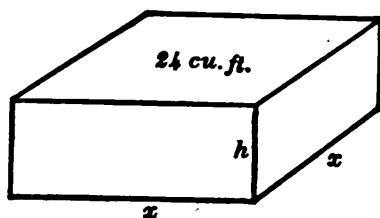

FIG. 18.

Ex. I. Find the most economical dimensions for an open, rectangular, sheet-iron box, which is to have a square base and contain 24 cu. ft. (Fig. 18.)

Let us try various dimensions, and calculate each time the number of square feet of material required.

If  $x = 2$ : base area = 4 sq. ft.

To give a volume of 24 cu. ft., this requires a height of 6 ft. The total area of the four sides and base will then be

$$A = 4hx + x^2 = 4(6)(2) + 2^2 = 52.$$

In like manner for  $x = 3, 4, 5$ , etc., we find the other areas shown in Table I.

TABLE I

$x$	$A$	$x$	$A$
2	52	5	44.2
3	41	6	52
4	40		

The smallest value here is  $A = 40$  when  $x = 4$ ; but a smooth graph shows a still smaller value between 3 and 4: viz.  $A = 39.6$ , at  $x = 3.6$ , approx. (Fig. 19.)

Thus the base should be about 3.6 ft. square, which requires a height of 1.8 ft., approx. (How could the best values of  $x$  and  $h$  be found still more closely?)

In any such problem it is well to start experimenting with values near those we think will be the best. But we should go on a little beyond any supposed maximum or minimum.

The table should have but two columns: The quantity for which we tried values and the quantity to be made a maximum or minimum.

§ 18. **Caution.** A few questions about maxima and minima can be answered by elementary geometry, but we should never jump at conclusions in such matters.

*E.g.*, it would not do to argue that the box in § 17 should be a cube to have the least area. We were not dealing with a *complete* area: there was no top.

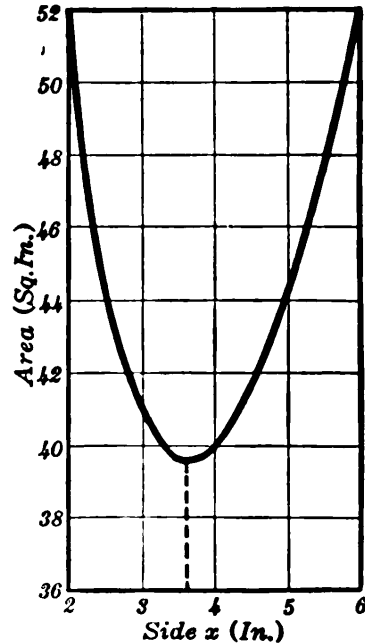

FIG. 19.

## EXERCISES

(Work these by experimenting and plotting results)

1. A rectangle is to have a perimeter of 30 in. For what dimensions will its area be greatest? Do these come out as you would expect?



2. A long sheet of tin 25 in. wide is to be made into a gutter, by turning strips up vertically along the two sides. How many inches should be turned up at each side to secure the greatest carrying capacity, i.e., the greatest sectional area?

3. A sheet of tin 20 in. square is to be made into an open box, by cutting out equal squares at the four corners and turning up the resulting side strips. Find the size of the squares to cut out to give the resulting box the maximum volume. What maximum? (Hint: What if 1 in. squares are cut out? 2 in. squares, etc.?)

4. A rectangular sheep pen including 120 sq. yd. is to be built against a long wall any part of which can be used as one side of the pen. What lengths should the three new sides have to require the smallest amount of new construction?

5. One ship ( $S$ ) was 80 mi. straight north of another ( $S'$ ) at noon. But  $S'$  was sailing east 12 mi. per hour and  $S$  was sailing south 16 mi. per hour. When were they nearest, and how near? (Calculate their distance apart at 1 P.M., at 2 P.M., etc., remembering that in any right triangle the square of the hypotenuse equals the sum of the squares of the two legs. Use tables of square roots if desired.)

6. In Ex. 2 above suppose the tin 30 in. wide and a 10-in. strip turned up at each side, perhaps not vertically (Fig. 20). For what depth will the gutter have the greatest capacity? (For any chosen value of  $y$ , the value to be used for  $x$  must be:  $x = \sqrt{100 - y^2}$ . Why?)

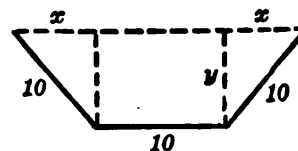

FIG. 20.

7. The load ( $L$  lb.) which a rectangular beam of a certain length can carry is  $L = 10xy^2$ , where  $x$  and  $y$  are the width and depth of beam in inches. Find what  $x$  and  $y$  give the strongest beam that can be cut from a circular log 20 in. in diameter.

8. A printed page is to allow 60 sq. in. for printed matter and have a margin of 1 in. at each side and  $1\frac{1}{2}$  in. at top and bottom. (Thus, if the print lines are 10 in. long, the height of the print column must be 6 in., making the page 12 in. wide and 9 in. high.) What shape of page will require the least paper?

9. For a package to go by parcel post the sum of its length and girth must not exceed 84 in. What are the dimensions and volume of the largest rectangular package, with square ends, that can go?

10. A rectangular stockade is to contain 600 sq. yd. The fences running one way will cost \$3 per yd., the other two \$2 per yd. What dimensions will make the cost of fencing least, and how small?

11. Like Ex. I, p. 32, but containing 120 cu. ft.

12. A covered rectangular tank is to have a square base and contain 60 cu. yd. The base will cost \$3 per sq. yd., the sides and top \$2 per sq. yd. Find the most economical dimensions.

13. Like Ex. 3 above for a sheet  $20 \times 30$ .

14. In Ex. 7 what  $x$  and  $y$  will give the *largest* beam that can be cut from the given log? Do these come out as you would expect?

[15.] Suggest some way to solve the equation  $4x^3 - 7x^2 + 15 = 0$ . (Hint: The question really is this: What values for  $x$  will make the quantity  $4x^3 - 7x^2 + 15$  equal to zero?)

### (E) THE ZERO-VALUE PROBLEM

§ 19. **Elementary Equations Reviewed.** In practical work it is often necessary to solve an equation for some unknown quantity. This can be done in any ordinary case, at least approximately, by a simple graphical process. Before discussing this, however, it may be well to recall that certain kinds of equations can be solved exactly by elementary algebra, as indicated below. If these methods are not already familiar, they should be thoroughly mastered now.

#### Linear Equations

Any equation of the first degree (*i.e.*, involving only the first power of the unknown quantity) can be solved by a simple transposition and division.

Ex. I. Solve  $2x + 5 = 0$ .

Evidently  $2x = -5$ , whence  $x = -\frac{5}{2}$ .

*Check*: Substituting  $-\frac{5}{2}$  for  $x$  does make  $2x + 5$  equal to zero. Hence  $-\frac{5}{2}$  is the required "root." \*

#### Quadratic Equations

Any equation of the second degree can be solved by "completing the square." To understand this process observe that, in the square of any binomial such as

$$(x+7)^2 = x^2 + 14x + 49,$$

\* A root of an equation is a number which, substituted for the unknown quantity, will make the two members of the equation equal.

or, more generally,

$$(x+n)^2 = x^2 + 2nx + n^2,$$

the final term is *the square of one half the coefficient of  $x$* .

Thus if the quantity  $x^2 + 14x$  appeared in an equation, we could convert it into a perfect square by adding  $7^2$  or 49.

Ex. II. Solve  $3x^2 - 11x + 7 = 0$ .

Transposing and dividing:  $x^2 - \frac{11}{3}x = -\frac{7}{3}$ .

Adding to both members the square of one half the coefficient of  $x$ :

$$x^2 - \frac{11}{3}x + \left(\frac{11}{6}\right)^2 = -\frac{7}{3} + \frac{121}{36} = \frac{25}{36}.$$

The left member is now a perfect square. Extracting square roots:

$$x - \frac{11}{6} = \pm \frac{\sqrt{37}}{6},$$

$$x = \frac{11 + \sqrt{37}}{6} \text{ or } \frac{11 - \sqrt{37}}{6}.$$

*Check:* Direct substitution shows these to be roots of the equation:

$$3\left(\frac{11 \pm \sqrt{37}}{6}\right)^2 - 11\left(\frac{11 \pm \sqrt{37}}{6}\right) + 7, \text{ simplified, gives zero.}$$

*Remark.* If we approximate  $\sqrt{37}$  by decimals, the results cease to be exact. But they will be more convenient for most purposes.

**§ 20. Equations as Problems of Variation.** Judged by the foregoing methods, the problem of solving an equation does not appear to be connected with our basic problem of determining how one quantity will vary with another. But it is.

For instance, we may think of the equation in Ex. II above as follows: For every value of  $x$ , whether a root or not, the quantity  $3x^2 - 11x + 7$  has a definite value, and it must therefore vary with  $x$  in a definite way. The problem of solving the equation

$$3x^2 - 11x + 7 = 0,$$

is simply the problem of *finding where this varying quantity  $3x^2 - 11x + 7$  reaches the value zero*.

The same idea will evidently apply to any other equation. And this suggests the following general method of solution.



§ 21. **Graphical Solution of Higher Equations.** There is no very elementary algebraic method of solving equations of the third degree or above, unless factors can be seen by inspection. But the real roots of *any equation of any degree* can be approximated graphically, if the equation contains only one unknown quantity.

For instance, if we wish to solve the equation

$$2x^3 - 15x + 10 = 0,$$

we simply plot a graph showing how the polynomial  $2x^3 - 15x + 10$  varies with  $x$ , and read off the values of  $x$  where the polynomial becomes zero.

The first step is, of course, to calculate a table of values of the polynomial by substituting various values for  $x$ :

$$x=4, \text{ poly.} = 2(4)^3 - 15(4) + 10 = 78;$$

$$x=3, \text{ poly.} = 2(3)^3 - 15(3) + 10 = 19;$$

and similarly for the other values in the adjacent table.

Plotting these values gives the curve in Fig. 21, negative ordinates being drawn downward as usual. The height of this graph at any point represents the value of the polynomial at the corresponding value of  $x$ .

$x$	POLY.
4	78
3	19
2	-4
1	-3
0	10
-1	23
-2	24
-3	1
-4	-58

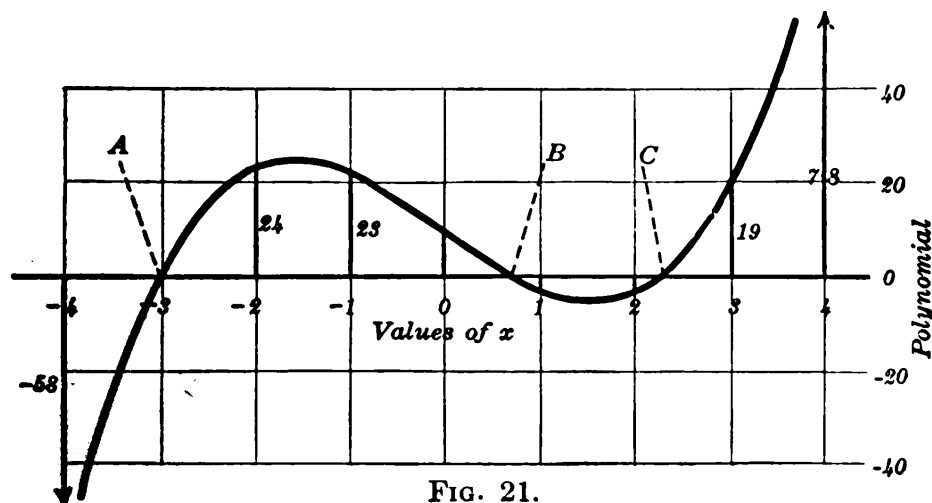

FIG. 21.

*Evidently the polynomial becomes zero at the crossing points A, B, and C, where  $x = -3.03, .71,$  and  $2.31,$  approx. These values are very close to the true roots of the given equation.*

These roots could be found roughly from the table without plotting. *E.g., since the polynomial is negative at  $x=2,$  and positive at  $x=3,$  we set it equal to zero somewhere between, and use "Proportional Parts." This gives  $x=2.17,$  — a value less accurate than the graphical result above. (Why should there be a discrepancy?)*

$x$	POLY.
1	$\left\{ \begin{array}{l} 3 \\ \Delta \left\{ \begin{array}{l} 19 \\ 0 \end{array} \right\} 4 \\ 2 \\ -4 \end{array} \right\} 23$

Further methods of solving equations will be discussed in Chapter IX.

**§ 22. Number of Roots: Imaginaries.** An equation of the first degree has a single root; one of the second degree has two; and in general (as is proved in higher algebra) an equation of the  $n$ th degree has  $n$  roots. These may be either "real" or "imaginary."

By an imaginary number, you will recall, is meant a number involving the square root (or any even root) of a negative number, — *e.g.,*  $2 + \sqrt{-5}.$  Such a number cannot be approximated by "real" numbers, either positive or negative. Hence imaginary values *cannot be represented graphically,* as long as we use scales consisting of real numbers. If any of the roots of an equation are imaginary, they will therefore not show in the graph.

So, if we find only a few roots for an equation of high degree, it may mean that the others are imaginary. Or it may mean that we have not carried the graph far enough. Even if the curve has risen exceedingly high, possibly it will presently fall and cross the base line again. Fortunately, a sure and simple test as to this is available. (§ 23.)

The names "real" and "imaginary" are very misleading, as they suggest that one kind of number actually exists and that the other does not. The fact is, these are merely *different kinds* of numbers.

Imaginary numbers can be given a perfectly concrete interpretation, which makes them exceedingly useful in Electrical Engineering. (Chapter XV.)

## EXERCISES

1. Solve by completing the square:

(a)  $2x^2 - 9x + 3 = 0,$

(b)  $3x^2 - 4x - 20 = 0,$

(c)  $12x^2 - 10x + 3 = 0,$

(d)  $5x^2 + 2x + .2 = 0,$

(e)  $x^2 + 4x + 13 = 0,$

(f)  $11x^2 + 6x - 9 = 0,$

(g)  $x^4 - 5x^2 + 4 = 0,$

(h)  $2x^4 + 5x^2 - 11 = 0,$

(i)  $3x^2 + 7x + c = 0,$

(j)  $5x^2 + bx - 7 = 0.$

2. In Ex. 2, p. 33, how many inches should be turned up to give the rectangle an area of 60 sq. in.?

3. How wide a margin (top, bottom, and sides alike) on a page 9 in. by 6 in. would leave 36 sq. in. for printed matter?

4. For a simple beam loaded and supported in a certain way, the "bending moment" at any distance ( $x$  ft.) from one end is  $M = 20x - x^2$ . For what value of  $x$  will  $M = 80$  exactly?

5. Solve graphically:

(a)  $x^3 - 4x + 2 = 0,$

(b)  $x^3 - x - 7 = 0,$

(c)  $x^3 - 3x + 11 = 0,$

(d)  $x^4 + x^3 - 12x^2 + 3 = 0.$

6. In Ex. 5 (b) check by completing the square. Also find the roots directly from the table used in Ex. 5 (b). Why the discrepancies?

7. When a sphere of diameter 3 ft. and specific gravity  $8/9$  floats in water, the depth of immersion ( $x$  ft.) is a root of the equation  $2x^3 - 9x^2 + 24 = 0$ . Find that root. (Why must the other two roots be excluded?)

8. In finding the maximum deflection of a 25-ft. beam loaded in a certain way it is necessary to solve the equation

$$4x^3 - 150x^2 + 1500x - 3125 = 0 \text{ for } x. \text{ Do this.}$$

9. Determine the approximate location of the "real" roots of:

(a)  $x^3 + 3x^2 - 3x - 18 = 0,$

(b)  $x^3 - 41x^2 + 440x - 495 = 0.$

Apparently how many in each case?

10. In Ex. 9 (b) test the value of the given polynomial at  $x = 20$ . Does this indicate further roots?

11. Solve for  $x$ :  $x + 2\sqrt{x-5} = 8$ . Check your results.

12. What is the erroneous step in the following "proof" that  $4 = 5$ ?

Since

$$(4)^2 - 9(4) = (5)^2 - 9(5),$$

$$\therefore (4)^2 - 9(4) + \frac{81}{4} = (5)^2 - 9(5) + \frac{81}{4}.$$

Hence, extracting square roots:

$$4 - \frac{9}{2} = 5 - \frac{9}{2}.$$

$$\therefore 4 = 5.$$

§ 23. **Synthetic Substitution.** In solving an equation graphically, the table of values is best calculated by the following method.

*Illustration.* To substitute 2 for  $x$  in the polynomial

$$5x^3 + 13x^2 - 16x - 20,$$

multiply the first coefficient (5) by 2, and add to the next coefficient (13); multiply the sum by 2, and add to the next coefficient ( $-16$ ), etc.

$$\begin{array}{r} 5 \quad +13 \quad -16 \quad -20 \quad | \underline{2} \\ \quad \quad 10 \quad +46 \quad +60 \\ \quad \quad \underline{+23} \quad \quad \underline{+30} \quad \quad \underline{+40} \end{array}$$

The final result, 40, is the value of the polynomial when

$$x = 2.$$

This can be verified by substituting directly:

$$5(2)^3 + 13(2)^2 - 16(2) - 20 = 40$$

The reason this process works is a simple one: Multiplying the 5 by any value of  $x$  and adding the 13 gives  $5x + 13$ ; multiplying this sum by  $x$  and adding the  $-16$  gives  $5x^2 + 13x - 16$ ; multiplying this sum by  $x$  and adding the  $-20$  gives  $5x^3 + 13x^2 - 16x - 20$ , which is the value of the polynomial. In other words, by multiplying by  $x$  at each stage, before introducing the next coefficient, we have multiplied each coefficient by  $x$  the proper number of times in all.

To illustrate further, let us substitute  $-4$  for  $x$ :

$$\begin{array}{r} 5 \quad 13 \quad -16 \quad -20 \quad \underline{-4} \\ \quad -20 \quad \quad 28 \quad -48 \\ \hline \quad -7 \quad \quad 12 \quad -68 \end{array}$$

The result is  $-68$ . Check this. Also examine these steps carefully.

This process is quicker than direct substitution. Also it shows with certainty when we have gone far enough to get all the real roots.

*E.g.*, in the present case, there can be no root above 2 nor any below  $-4$ . For substituting  $-5$  or  $-6$ , etc., instead of  $-4$ , would simply make each successive product and sum numerically larger, while keeping their signs alternately  $+$  and  $-$ , and could not produce a final zero. Nor could the substitution of  $+3$  or  $+4$ , etc., instead of  $+2$ . (Why not?)

In any case, we have gone far enough in the negative direction when the successive sums *alternate in sign, beginning with the leading coefficient*; and far enough in the positive direction when the sums *are all positive*.

If any power of  $x$  is lacking in a given polynomial, its coefficient is zero; and *this zero must be inserted*.

Thus, to substitute in  $2x^5 - 15x^3 + x^2 + 7x$ , use the coefficients

$$2 + 0 - 15 + 1 + 7 + 0,$$

since  $x^4$  and the constant term are missing. (Observe the  $x^2$  term here.)

### EXERCISES

1. Find approximately the real roots of

$$\begin{array}{ll} (a) x^3 - 4x^2 - 3x + 11 = 0, & (b) x^3 - 7x + 5 = 0, \\ (c) x^4 - 2x^3 - 8x^2 + 3 = 0, & (d) x^3 - 6x - 13 = 0, \\ (e) x^4 - x^3 - 20x^2 - 5 = 0, & (f) x^5 - 10x + 15 = 0, \\ (g) x^3 - 8x^2 + 15x - 6 = 0, & (h) x^3 - 13x^2 + 11 = 0. \end{array}$$

2. The length ( $L$  ft.) of the longest rectangular panel 1 ft. wide which can be fitted diagonally across a door 4 ft. wide and 10 ft. long is a root of the equation  $L^4 - 118L^2 + 160L - 115 = 0$ . Find it.

3. The smallest safe diameter ( $d$  in.) for the bolts in a certain steel shaft is a root of the equation  $d^4 + 320d^2 - 340d - 4290 = 0$ . Find it.

4. Determine the approximate location of all the real roots of the following equations :

$$(a) \quad x^4 - 39x^3 + 354x^2 + 640x - 2500 = 0,$$

$$(b) \quad x^3 + 17x^2 + 40x - 290 = 0.$$

(Suggestion : Try values widely separated at first to get an idea of how the polynomial runs.)

### (F) THE PROBLEM OF EXACT REPRESENTATION

§ 24. **Formulas.** One way to show how any given quantity varies with another is to draw a graph. Another way, also very common, is to write a *formula* or equation which tells the value of the varying quantity at any instant.

*Illustration.* If a bomb is dropped vertically, say from an airplane, the distance ( $s$  ft.) through which it will have fallen after  $t$  sec. is approximately

$$s = 16t^2. \quad (1)$$

For instance, after 2 sec.,  $s = 16(2)^2 = 64$ ; after 10 sec.,  $s = 16(10)^2 = 1600$ ; etc. The bomb will have fallen 64 ft. or 1600 ft., respectively; etc.

Evidently formula (1) is equivalent to a complete table of values of  $s$  for all values of  $t$ , — until the bomb strikes, after which the formula is no longer valid.

Formulas in general give very full information in a very brief form; and they can be carried around much more easily than a graph, or can even be memorized. Moreover, they can be used to *make exact calculations*, — even for rates in very small intervals where a graph ceases to give reliable results.

To illustrate in the case of the falling bomb, let us find from formula (1) the average speed, or rate of motion, during an interval of .01 sec. beginning at the instant  $t = 3$ .

$$\text{At } t = 3, \quad s = 16(3)^2 = 144.$$

$$\text{At } t = 3.01, \quad s = 16(3.01)^2 = 144.9616.$$

During the .01 sec., therefore, the bomb falls .9616 ft. Hence its average speed is

$$v = \frac{.9616}{.01} \text{ (ft./sec.)} = 96.16 \text{ (ft./sec.)}.*$$

*Remarks.* (I) Properly, the coefficient of  $t^2$  in formula (1) should be 16 plus a small fraction, depending on the latitude of the place. But even this would ignore the effect of air resistance. So, in illustrative examples we shall always use the value  $16 t^2$  for simplicity.

We shall also, as in Physics, use the notation  $s$  for the "space" or distance traveled, and  $v$  for the "velocity" or speed. Do not mistake  $s$  for speed.

Any algebraic expression involving  $x$ , whether it has any concrete meaning or not, may be regarded as a function of  $x$ , for it will vary with  $x$  in some definite way. *E.g.*, the quantity  $2x^3 - 15x + 10$  varies with  $x$ , as shown in Fig. 21, p. 37. Any formula, then, such as  $y = x^2$ , expresses  $y$  algebraically as a function of  $x$ .

**§ 25. Increment Notation.** In calculating rates, etc., it is desirable to have a short notation for the change in one quantity produced by any change in another.

We have already used  $\Delta$  (delta) to stand for a difference or change in a quantity. Hereafter we shall affix the name of the quantity to prevent any possible ambiguity. Thus

$\Delta x$  will denote a difference or change in  $x$  ;

$\Delta y$  will denote the corresponding change in  $y$ .

Observe that  $\Delta x$  does not denote some quantity  $\Delta$  times the quantity  $x$ , but simply the change in  $x$ , as stated.

In this notation the average rate of increase in  $y$  per unit change in  $x$  can be expressed simply as  $\Delta y / \Delta x$ .

\* This, by the way, must be nearly the same as the *speed at the instant*  $t = 3$ .

Similarly, in § 24, since  $s=144$  when  $t=3$ , and  $s=144.9616$  when  $t=3.01$ , we may write

$$\begin{aligned} \Delta s &= .9616, & \Delta t &= .01. \\ \therefore \frac{\Delta s}{\Delta t} &= 96.16 = \left\{ \begin{array}{l} \text{average rate of increase of } s \text{ per} \\ \text{unit change in } t \text{ during this } .01 \text{ sec.} \end{array} \right. \end{aligned}$$

**§ 26. Plotting a Formula.** From any given formula we can calculate as extensive a table of values as we like, and plot a graph, — to be used thereafter as a ready computer in reading off further values. This is especially desirable when the formula is very complicated.

For instance, the graph of the cost of oil-tanks, shown in Fig. 7, p. 5, saves the designer several hours on each calculation.

Any graph which happens to be straight makes a good computer, if drawn with a ruler on accurate paper.

### EXERCISES

1. The assessed value ( $\$V$ ) of a certain house  $t$  years after construction will be  $V=2000-30t$ . Plot this from  $t=0$  to  $t=40$ , calculating  $V$  every five years. What sort of graph? How do the original value and the rate of change appear in the formula? In the graph?

2. In the formula  $y=a+bx$  what is the value of  $y$  when  $x=1, 2, 3, 4; k, k+1$ ? How much does  $y$  increase every time that  $x$  increases by 1 unit? Hence what sort of graph must every formula of this type (first degree) have? How many points are needed to plot it?

3. The amount which would accumulate on an original sum of  $\$100$  after  $t$  years with simple interest at 6% is  $A=100+6t$ . (Why?) Plot this from  $t=0$  to  $t=70$ . Answer the same questions as in Ex. 1. Also read off  $A$  when  $t=55$ .

4. The distance ( $s$  ft.) that an object will fall (from rest) in  $t$  sec. is  $s=16t^2$ . (A) Calculate  $s$  at  $t=3$ ; also the average speed during .02 sec. beginning then. (B) Plot  $s$  as a function of  $t$  from  $t=0$  to  $t=5$ ; and check the calculated speed.

5. The height of a ball  $t$  sec. after being thrown straight upward was  $h=112t-16t^2$  feet. Plot. When was the ball highest and how high? When was it 80 ft. high? Check the latter answer by putting  $h=80$  and solving the equation for  $t$ .



6. In Ex. 5 calculate the average rate at which the ball rose from  $t=2$  to  $t=2.01$ . Check by the graph.

7. At any horizontal distance ( $x$  ft.) from the middle of a certain suspension cable the height ( $y$  ft.) above the lowest point is given by  $y = .002 x^2$ . Plot the curve of the cable from  $x=0$  to  $x=80$ . How fast does the cable rise on the average, per horizontal foot, between  $x=60$  and  $x=62$ ? Check graphically.

8. Every horizontal section of a reservoir is a square, whose side varies thus with the height ( $h$  ft.) above the bottom:  $s = 30 + 3h$ . (A) Plot this from  $h=0$  to  $h=10$ . Also plot the area of the section as a function of  $h$  from 0 to 10.

9. In Ex. 8 find how much water must flow in to increase the depth from 4 ft. to 10 ft.

10. The speed of an object ( $v$  ft./sec.) after falling  $s$  ft. freely from rest is, approximately,  $v = 8\sqrt{s}$ . Plot from  $s=0$  to  $s=36$ . (Hint: Use  $s=1, 4, \frac{9}{4}, 9$ , and other perfect squares.) Read off  $v$  when  $s=10, 11, 12, \dots$ , to 20.

11. The time ( $T$  sec.) of a complete swing for a pendulum of length  $l$  in. is:  $T = .32\sqrt{l}$ . By changing the vertical scale make the graph in Ex. 10 serve for this formula. Read off  $T$  if  $l=6, 12, 18, 24, 30$ .

[12.] Plot a graph showing how the quantity  $y = 60/(x-3)$  varies with  $x$ , from  $x=-2$  to  $x=7$ . Then find from the equation the value of  $y$  when  $x=3.01$ , and when  $x=2.99$ . Is there any indication of the upper and lower parts of the graph turning toward each other?

§ 27. Varieties of Graphs. The character of the graph of an algebraic function depends upon the type of formula.

*E.g.*, if a formula is *linear*, — *i.e.*, of the first degree, the graph is *straight*. (See Ex. 2, p. 44.) To plot it we need calculate but two points, well separated, and join these by a straight line. A third point is desirable as a check.\*

Again, if a function is *irrational*, substituting certain values for  $x$  may give imaginary results, — which cannot be plotted. Thus  $\sqrt{25-x^2}$  is real only between  $x=-5$  and  $x=+5$ , and its graph does not go beyond these values.

Again, the graph of a *polynomial*, — *i.e.*, the sum of integral

\* A function like  $20/(2x-5)$  which involves  $x$  in the *denominator* is not called linear; but only expressions of the form  $ax+b$ .

powers of  $x$  with given coefficients, — such as  $2x^3 - 15x + 10$ , is a *smooth curve*, as in Fig. 21, p. 37. But the graph of a function which has  $x$  in the denominator may be startlingly different. (See § 28.)

§ 28. **A Necessary Precaution**, illustrated. Let us plot the graph of the function

$$y = \frac{60}{2-x} \quad (2)$$

from

$$x = -4 \text{ to } x = 8.$$

Substituting values for  $x$  gives the adjacent table.

$x$	$y$	$x$	$y$
-4	10	3	-60
-3	12	4	-30
-2	15	5	-20
-1	20	6	-15
0	30	7	-12
1	60	8	-10
2	?		

(What happens when  $x=2$  will be discussed shortly.)

From  $-4$  to  $1$  and from  $3$  to  $8$ , the graph runs as indicated by the curve in Fig. 22. Let us follow the left-hand branch and see where it joins the other part.

Substituting again in the given formula :

at  $x = 1.9, \quad y = \frac{60}{2-1.9} = 600;$

at  $x = 1.99, \quad y = \frac{60}{2-1.99} = 6000.$

Evidently the curve is climbing faster and faster, and is not approaching the other branch. Follow the latter back :

at  $x = 2.1, \quad y = \frac{60}{2-2.1} = -600;$

at  $x = 2.01, \quad y = -6000.$

The farther we follow either branch toward  $x=2$ , the farther it goes from the other, — enormously! What is the explanation? How about  $y$  when  $x=2$  exactly?

The formula then reads:  $y = \frac{0}{0}$ . But **division by zero is impossible.** (§ 29, below.) Hence  $\frac{0}{0}$  is a meaningless symbol: it does not stand for zero, nor for any other number. That is, no value exists for  $y$  when  $x=2$ .

This explains the peculiarity of the graph. The curve *nowhere crosses the vertical line at  $x=2$* ; for if it did, the ordinate at the crossing would give a definite value for  $y$  when  $x=2$ .

Hence the graph consists of two entirely separate branches. There is a tremendous break at  $x=2$ : the function is “discontinuous” there.

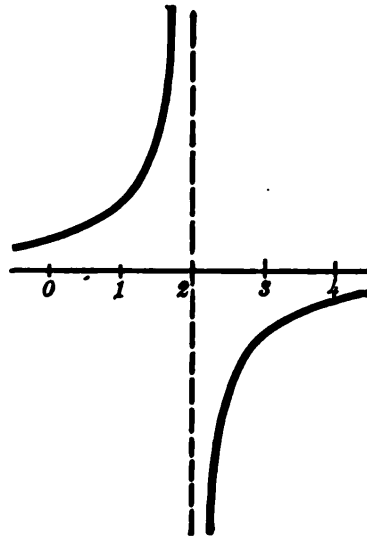

FIG. 22.

*Remark.* In general, whenever a function involves a fraction, we must see whether any real value of  $x$  will reduce the denominator to zero, and the numerator to some other value. If so, the curve will break. To make sure about this, simply set the denominator equal to zero, solve for  $x$ , and then test near-by values.

**§ 29. Operations with Zero.** We can multiply by zero, add or subtract zero, subtract any number from zero, or divide zero by any other number, — in short, perform every numerical operation with zero except one:

**We cannot divide by zero.**

For instance, to divide 60 by zero we should have to find a quotient which, multiplied by zero, would give 60:

$$\text{if } \frac{60}{0} = Q, \quad \text{then } 60 = 0 \cdot Q.$$

But no such quotient exists: *any number whatever, multiplied by zero, gives zero and not 60.*

Erroneous statements are often made in this connection about "infinity," — whatever that may be. The correct statement is that we cannot divide by zero.\*

Observe further that such an expression as  $7 + \frac{0}{0}$  would also be meaningless. We could no more add a number to  $\frac{0}{0}$  than we could add a number to a color!

**§ 30. Reciprocal Numbers.** One number is called the reciprocal of another if their product is  $+1$ .

Thus the reciprocal of 3 is  $\frac{1}{3}$ ; the reciprocal of  $-\frac{2}{3}$  is  $-\frac{3}{2}$ ; etc. To find the reciprocal of any number, simply divide 1 by that number.

Every number except zero has a reciprocal. But  $\frac{1}{0}$  does not exist.

**§ 31. Writing Formulas for Laws of Variation.** To use mathematics effectively in scientific work, we must know the meaning of certain common statements concerning the variation of quantities, and must be able to translate those statements into equations. The following are particularly important:

(I) When we say that one quantity is *proportional to* another, or *varies as* that other, we mean that *the ratio of the two is constant*, — that doubling the one will double the other, etc.

For instance, if  $y$  varies as  $x^2$ , then

$$\frac{y}{x^2} = k, \quad \text{or } y = kx^2, \quad (3)$$

where  $k$  is some constant.

(II) To say that one quantity *varies inversely as* another means that it varies as the *reciprocal* of that other.

Thus if  $y$  varies inversely as  $x^4$ , then  $y$  varies as  $1/x^4$ , or

$$y = k \left( \frac{1}{x^4} \right) = \frac{k}{x^4}.$$

\* An explanation of the proper technical use of the term "infinity" may, of course, be given at this point, or postponed, at the discretion of the instructor. See Appendix, p. 493.

(III) To say that  $y$  varies as  $u$  and as  $v$  means that it varies as their product:  $y = k(uv)$ . And so on.

*N.B.* Observe that the phrase "varies as  $x$ " has a very definite technical meaning, but that  $y$  might vary *with*  $x$  in any way whatever.

Observe also that we can find the constant  $k$  in any of the cases above, if we know the value of  $y$  corresponding to any value of  $x$ , — or  $u$  and  $v$ .

Thus, in equation (3), if  $y = 36$  when  $x = 2$ , we must have

$$36 = k(2^2), \quad \therefore k = 9.$$

And the definite formula for  $y$  would then be  $y = 9x^2$ .

### EXERCISES

1. Draw the graphs of the following between  $x = -30$  and  $+40$ ; then read off the value of  $y$  at  $-13$  and  $+27$ , and check.

$$(a) y = 2x - 5, \quad (b) y = -.4x + 20, \quad (c) y = \frac{3}{4}x + 10.$$

2. The voltage of a certain dynamo ( $Y$  volts) varies thus with the speed ( $X$  rev./min.):  $Y = .817X$ . Plot from  $X = 0$  to  $X = 900$ . Find  $Y$  if  $X = 225$ ; also  $X$  if  $Y = 560$ .

3. Plot these formulas over the same base line:  $y = \frac{1}{2}x$ ,  $y = \frac{1}{2}x + 7$ ,  $y = \frac{1}{2}x - 4$ . Similarly for this set:  $y = x + 2$ ,  $y = .3x + 2$ ,  $y = -x + 2$ . What graphical significance have  $a$  and  $b$  in the formula  $y = a + bx$ ?

4. Find by inspection whether the graphs of the following formulas break; and if so, where:

$$(a) y = \frac{70}{x+5}, \quad (b) y = \frac{60x}{x^2+1}, \quad (c) y = \frac{x^2+10}{x-4},$$

$$(d) y = \frac{x-1}{x-3}, \quad (e) y = \frac{60x}{x^2-1}, \quad (f) y = \frac{x+x-2}{x^2+9}.$$

Plot the graph for (d), testing  $y$  near any supposed break.

5. When an object  $x$  in. away is photographed with a lens of "focal length"  $F$  in., the plate should be at a distance  $y$  in. from the lens, given by the formula  $y = Fx/(x-F)$ . Taking  $F$  as 25, plot  $y$  from  $x = 0$  to  $x = 90$ . Read off  $y$  for  $x = 12.5$ , and for  $x = 75$ . (Values of  $x$  less than 25 correspond to imaginary or "virtual" images.)

6. For quartz the "index of refraction" ( $n$ ) varies thus with the frequency of light vibration ( $f$  trillion per sec.):

$$n^2 = 1.354 + \frac{1156}{1156 - f^2}$$

Plot  $n^2$  as a function of  $f$ , from  $f=10$  to  $90$ , substituting  $10, 20$ , etc., also  $35$ . Read off  $n^2$  when  $f=25; 38; 77$ . (Imaginary values of  $n$  correspond to an "absorption band," — as explained in Physics.)

7. The time of revolution ( $T$  yr.) for a planet at a distance of  $x$  units from the sun is  $T = \sqrt{x^3}$ . [For the earth,  $x=1$ .] Plot from  $x=0$  to  $35$ . Read off the value of  $T$  for  $x=5.2$  (*Jupiter*); also  $x$  if  $T=30$  (*Saturn*).

*In each of the following, obtain the formula expressing the law of variation, and calculate the further values asked for.*

8. The elongation of a "spring-balance" varies as the weight applied. If  $E=4$  when  $W=50$ , what is the formula? Find  $E$  when  $W=35$ .

9. The volume of a gas under constant pressure varies as the "absolute temperature." If  $V=600$  when  $T=300$ , what is the formula? What  $V$  for  $T=347$ ? What  $T$  gives  $V=570$ ?

10. The volume of a gas at constant temperature varies inversely as the pressure applied. If  $V=300$  when  $p=15$ , what is the formula? Find  $V$  when  $p=12; 20; 30$ .

11. The maximum range ( $R$  meters) of a projectile varies as the square of the velocity ( $V$  m/sec.) with which it starts. If  $R=18000$  when  $V=500$ , what formula? What  $R$  for  $V=400$ ? For  $V=550$ ?

12. The acceleration which gravity imparts to an object ( $A$  ft./sec.<sup>2</sup>) varies inversely as the square of the distance ( $R$  mi.) from the center of the earth. If  $A=32$  when  $R=4000$ , what formula? Find  $A$  when  $R=8000; 200,000$ .

13. The consumption of coal ( $C$  tons/hr.) in a locomotive varies as the square of the speed maintained. If  $C=2$  when  $v=20$ , what formula? Find  $C$  if  $v=30$ . What  $v$  if  $C=20$ ?

14. The speed of a falling object varies as the square root of the distance fallen (from rest). If  $V=80$  (ft./sec.) when  $s=100$  (ft.), what formula? Find  $V$  when  $s=900$ .

15. An electric current varies inversely as the resistance of the circuit. If  $C=3$  (amperes) when  $R=5$  (ohms), find  $C$  when  $R=4; 15; 90$ .

**§ 32. Discovering Linear Formulas.** In working with scientific formulas, the question naturally arises as to how they are obtained in the first place.

Some are derived by reasoning from known principles, but many others are *discovered empirically*. That is, experiments are performed, or observations made, and the results noted

in the form of a table of values. The question then is purely mathematical: *To find a formula satisfied by all the values in a given table.*

There is no one process by which this can always be done. But we shall from time to time see how all the more common types of laws can be discovered. At present only the simplest case will be considered.

**THEOREM.** If a quantity  $y$  increases at a constant rate per unit change in another variable  $x$ , the formula for  $y$  in terms of  $x$  must be linear, — *i.e.*, of the first degree.

**PROOF.** Let the value of  $y$  when  $x=0$  be denoted by  $a$ , and the constant rate of increase by  $b$ . Then, when  $x$  has increased from 0 to any value  $X$ ,  $y$  will have increased by  $bX$  (or  $b$  units per unit change in  $x$ ). Thus  $y$  will equal its original value  $a$  plus its increase  $bX$ :

$$y = a + bX.$$

That is, for every value of  $x$ ,  $y$  is given by a linear formula. (*Q. E. D.*)

To find what values  $a$  and  $b$  should have in any particular case, we may proceed as in Ex. I below.

**Ex. I.** Table I shows the amount of potassium iodide ( $W$  grams) which will dissolve in 100 grams of water, at several temperatures ( $T^\circ$ ). Find a formula for the amount which will dissolve at any temperature.

TABLE I

$T$	$W$	$T$	$W$
10	136	40	160
20	144	50	168
30	152	60	176

By inspection of the table,  $W$  increases at a constant rate. Hence the values all satisfy a formula of the type

$$W = a + bT. \quad (3)$$

For instance,

$$136 = a + 10b,$$

$$144 = a + 20b, \text{ etc.}$$

To find  $a$  and  $b$ , we simply take any two such equations formed by substituting from the table, and solve simultaneously. Subtracting eliminates  $a$  and gives  $b = .8$ . Substituting this in either equation gives  $a = 128$ .

That is, if formula (3) is to fit the given table, we must have  $a = 128$  and  $b = .8$ . Thus the required formula is

$$W = 128 + .8T.$$

*Remarks.* (I) When a table runs at irregular intervals, we may not be able to tell by inspection whether the rate is constant. But we can tell by *plotting a graph and seeing whether this is straight*.

(II) If the rate is not constant, the formula is not linear, and we cannot find it as yet. However, if the plotted values give an almost straight line and apparently not a smooth curve, we assume that there were slight experimental errors in making out the table, draw what seems to be the *most probable* straight line among the points, and find a formula to *fit this line*. A more reliable process will be explained later. (§§ 342–343.)

### EXERCISES

In each of the following exercises show that the formula is linear. Find it, and check for some value in the table.

TABLE 1

$T$	$W$
0	54
20	64
40	74
60	84
80	94

TABLE 2

$C$	$F$
10	50
60	140
100	212
160	320
200	392

TABLE 3

$T$	$V$
−33	160
−6	178
12	190
27	200
42	210

TABLE 4

$V$	$N$
3	4
8	11
13	18
18	25
23	32



TABLE 5

$T$	$L$
70	557
85	546
100	536
115	526
130	515

TABLE 6

$h$	$W$	$M$
61	118	124
63	126	132
65	134	140
67	142	148
69	150	157
71	158	166

TABLE 7

No.	Cost
1000	152.50
2000	165.
3000	177.50
4000	190.
5000	202.50

TABLE 8

$W$	POSTAGE	
	(III)	(VI)
5	.14	.41
10	.24	.81
15	.34	1.21
20	.44	1.61

1. Table 1 gives the weight of KBr salt ( $W$  grams) which will dissolve in 100 grams of water at various temperatures ( $T^\circ$ ). After finding and checking the formula, find  $W$  for  $T = 13$ .

2. Table 2 shows several temperatures Centigrade with their Fahrenheit equivalents. Find  $F$  when  $C = 190$ ; also  $C$  when  $F = 100$ .

3. Table 3 gives the volume ( $V$  cc.) of a certain quantity of gas at several temperatures ( $T^\circ$ ). What formula? Find  $V$  at  $T = 50$ .

4. The rate at which the indicator of a certain gas-meter revolves ( $N$  rev. per sec.) for various velocities of the gas in the pipe ( $V$  ft./sec.) is shown in Table 4. What formula? For what  $V$  is  $N = 0$ ?

5. The latent heat of steam ( $L$  calories) is shown in Table 5 for various temperatures ( $T^\circ$ ). Find an approximate formula by drawing what seems to be the most probable straight line graph.

6. Table 6 gives the average weights ( $W$  lb. and  $M$  lb.) of women and men of various heights ( $h$  in.). Express approximately the relation between weight and height in each case.

7. The cost of publishing a certain pamphlet will vary with the number ( $N$ ) to be printed, as shown in Table 7. Find  $C$  if  $N = 3200$ . What is the meaning of each constant in the formula?

8. The postage required for packages of various weights ( $W$  lb.) is shown in Table 8 for "Zones" 3 and 6. What are the formulas?

**§ 33. Summary of Chapter I.** It is often necessary to study the way in which some one quantity varies with another. What value will the one quantity have for any specified value of the other? What maximum and minimum values? What mean value? Is it ever zero? What is the average rate of increase in any interval? The rate at any instant?

If a table of values has been obtained, — say experimentally, — a graph can be plotted and used to answer such questions approximately. Precise answers should not be expected when our given information about the variable quantities is merely a table of values.

If, however, we know a *formula* which expresses one of the variable quantities as a function of the other, very accurate calculations are possible. We can get any desired value of the function exactly, also any average rate of increase. By dealing with very small intervals, we can find maximum and minimum values, mean values, and instantaneous rates as closely as may be desired, — though not exactly, as yet.

Any algebraic function or formula can be plotted, and the graph thereafter used as a ready computer. If a denominator becomes zero there will be a break in the graph.

The real roots of an equation of any degree can be approximated graphically, the synthetic method of substitution affording a sure test as to the sufficiency of the table. Interpolation by proportional parts is too inaccurate here, but is valuable when the intervals in a table are very small.

Any large error in a table of values can usually be discovered from the resulting irregularity in the graph.

*Remark.* The exact calculation of an instantaneous rate may at present appear almost hopeless, since we cannot select any interval, not even a small one, for which the average rate will surely equal the required instantaneous rate.

Nevertheless the calculation can be made easily as soon as we see clearly *just what an instantaneous rate is*. This and similar questions will be considered in the next chapter.

### EXERCISES

1. Which quantity would you plot vertically and which horizontally if you wished to show the relation between: The death rate of bacteria and the amount of sunshine? The temperature in a mine and

the depth below the surface of the ground? The impulsive force of a jet of water and the speed of flow?

2. Table 1 gives the pressure of steam at various high temperatures. Plot the graph.

3. The area of a wound,  $A$  sq. cm., decreased with the time,  $t$  days, as in Table 2. Plot the curve of healing. Find the rate at  $t=8$ .

4. Table 3 shows the cash surrender value ( $\$V$ ) of a certain life insurance policy after  $T$  years. Find graphically and by proportional parts what the value should be when  $T=12$ . (Why is there a discrepancy?) What is the rate of increase per year at  $T=20$ ?

5. Based on the level of 1895 as 100%, the average price of commodities in general has increased as in Table 4. The cost of electric power, however, has been reduced, as shown in the table. Exhibit these facts graphically, — using a common base line.

TABLE 1		TABLE 2		TABLE 3		TABLE 4		
$T$	$P$	$T$	$A$	$T$	$V$	YEAR	PRICE	ELEC.
240	10	0	16.2	0	0	1890	113	110
259.2	20	4	10.7	5	121	1894	96	101
274.3	30	8	6.5	10	291	1898	95	90
286.9	40	12	3.8	15	486	1902	113	75
297.8	50	16	2.1	20	727	1906	122	59
307.4	60	20	1.0	25	930	1910	126	27
316.0	70	24	.4	30	1000	1914	153	16
						1918	321	16

6. The angle ( $A$  mils) at which to elevate a certain machine gun for various ranges ( $R$  yd.) is shown in Table 5. Plot. What is the range if  $A=80$ ? Check by proportional parts. At what average rate must  $A$  increase with  $R$ , from  $R=1400$  to  $R=1600$ ?

TABLE 5

$R$	$A$	$R$	$A$
200	3	2000	95
500	10	2500	157
1000	29	2800	207
1500	56		

7. Table 6 gives the depth of a river ( $D$  ft.) at various distances  $x$  feet from one bank, going straight across. Find the approximate area of the cross-section of the river.

8. The rate at which a flywheel was turning ( $R$  deg./min.) while getting up speed was given by the formula:  $R=60 t^2(9-t)$ , where  $t$  is the number of minutes elapsed since starting. Plot and find the total angle turned from  $t=0$  to  $t=6$ . When was the maximum rate of rotation attained, and what maximum?

9. In Ex. 8, exactly how much did  $R$  increase from  $t=1$  to  $t=3$ ? Hence, what average angular acceleration (or rate of increase of  $R$ )? Check the latter result by the graph.

10. During the motion of a pendulum up and back, the speed ( $v$  in./sec.) varied with the time ( $t$  sec.), as in Table 7. (Negative values indicate a reversed direction of motion.) (a) Find  $v$  at  $t=.3$ ; also how fast  $v$  was then changing. (b) How far did the pendulum travel in reaching its highest point?

11. Solve graphically  $x^2+x-7=0$ . Check by completing the square. Also approximate one root by proportional parts. Why is this inaccurate?

TABLE 6

$x$	$D$
0	0
200	5
400	21
600	30
800	26
1000	37
1200	25
1400	0

TABLE 7

$t$	$v$
0	8.
.2	6.47
.4	2.47
.6	-2.47
.8	-6.47
1.0	-8.

12. Find approximately all the real roots of

$$(a) \quad x^3 - 12x + 88 = 0,$$

$$(b) \quad x^4 - x^3 - 12x^2 + 5 = 0.$$

13. In testing the insulation of certain telephone lines it is necessary to find the resistance from the formula

$$R = \frac{15\,000\,000}{V} - 100\,000,$$

for values of the voltage ( $V$ ) running from 1 to 150. Plot the graph for this interval. Would the complete graph break?

14. A wire was stretched, its length ( $L$  in.) varying with the pull ( $P$  lb.), as in Table 8. Find the formula for  $L$  in terms of  $P$ . Check. Tell how you would find the work done in stretching the wire from  $L=42.5$  to  $L=43$ .

15. The quantity ( $Q$  gal.) of a certain mineral water which can be sold at various prices ( $P$ ¢ per gal.) is shown in Table 9. The total expense ( $\$E$ ) of marketing those quantities is also shown. What price gives the greatest net profit?

16. Two burners  $A$  and  $B$ , 10 ft. apart, are of different power.  $A$  gives 60 calories a second at a distance of 1 ft.;  $B$ , 480 calories. The intensity varies inversely as the square of the distance. What point on the line  $AB$  receives the least heat from  $A$  and  $B$  combined; and how much heat?

17. Find the radius and length of the largest cylindrical package which can go by parcel post. See Ex. 9, p. 34.

18. The deflection of a beam varies as the cube of the length. If  $D=.002$  when  $L=10$ , find the formula giving  $D$  for any  $L$ . Find  $D$  when  $L=17$ .

TABLE 8

$P$	$L$
100	42.5
200	42.7
300	42.9
400	43.1
500	43.3

TABLE 9

$P$	$Q$	$E$
20	16200	2700
30	12800	2400
40	9800	2100
50	7200	1800
60	5000	1500
70	3200	1200

19. If the plates for printing a chart cost \$40.00 and the cost of printing is .6 cents per copy, what will be the total cost of  $x$  copies? Plot from  $x=1000$  to  $x=10,000$ . Read off the cost of 8750 copies. How many copies for \$75?

[20.] When you speak of the speed of a projectile at some *instant*, as distinguished from its average speed during some *interval* of time, what do you have in mind?

## CHAPTER II

### SOME BASIC IDEAS ANALYZED

#### THE EVER-RECURRING LIMIT-CONCEPT

§ 34. **Instantaneous Speed.** When we speak of the speed of a moving object at a certain *instant*, precisely what do we have in mind?

Not the average speed for the next hour, nor even for the next minute or second. Nevertheless the average speed for a very short interval would closely approximate the "instantaneous speed" of which we are thinking. And by making the interval shorter and shorter, we could bring the average speed closer and closer to the instantaneous speed.

In other words, the speed at any instant is simply the limiting value which the average speed would approach, as closely as we please, if the interval were indefinitely shortened, while always including the instant.

This statement will be taken as our definition of instantaneous speed.

To calculate an instantaneous speed *exactly*, we must somehow find the limiting value in question. To do this we shall first find the average speed in an interval of arbitrary length, — not a fixed interval such as .01 sec., but an elastic interval of *any* length. Then we shall squeeze this interval down as small as we please, and see what happens to the average rate.

Ex. I. Find the speed at which a ball was rising 3 sec. after it was thrown straight upward, if the height ( $h$  ft.) after  $t$  sec. was

$$h = 100 t - 16 t^2. \quad (1)$$

Consider any interval beginning at  $t=3$ ; and let  $\Delta t$  denote the length of time in the interval, — which therefore ends at  $t=3+\Delta t$ .

By (1) the heights at the beginning and end of the interval were

at  $t=3$ ,  $h = 100(3) - 16(3)^2 = 156$ ;

at  $t=3+\Delta t$ ,  $h = 100(3+\Delta t) - 16(3+\Delta t)^2$ ,  
 $= 156 + 4 \Delta t - 16 \Delta t^2$  (simplified).

*Handwritten notes:*  
 $h = 100(3 + \Delta t) - 16(3 + \Delta t)^2$   
 $h = 300 + 100\Delta t - 144 - 96\Delta t - 16\Delta t^2$   
 $h = 156 + 4\Delta t - 16\Delta t^2$

The difference of these heights,  $\Delta h = 4 \Delta t - 16 \Delta t^2$ , is the distance the ball rose during the interval of  $\Delta t$  sec. (Fig. 23.) Dividing by  $\Delta t$ :

$\frac{\Delta h}{\Delta t} = 4 - 16 \Delta t = \text{av. speed during } \Delta t.$

For instance, if  $\Delta t = .01$ , we have  $4 - 16(.01)$ , or 3.84, ft./sec. as the average speed from  $t=3$  to  $t=3.01$ .

Now let  $\Delta t$  approach zero. The limiting value approached by the average speed  $\leftarrow 4 - 16 \Delta t$  is precisely 4. That is, the instantaneous speed at  $t=3$  is precisely 4 (ft. per sec.).

Remarks. (I) We do not say that the average speed  $4 - 16 \Delta t$  will ever be exactly equal to 4. Neither will it ever be equal to the instantaneous speed. But the limiting value which the average speed is approaching is exactly 4; and this limiting value is precisely the instantaneous speed.

(II) If our resulting speed had come out negative, it would indicate that the ball was falling, — i.e., that the height was decreasing. (For it would show that the value of  $h$  at  $t=3+\Delta t$  was smaller than the value at  $t=3$ , which we subtracted, — at least, that this would be so when  $\Delta t$  became small.)

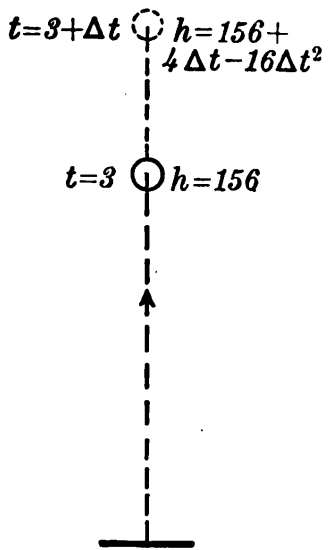

FIG. 23.

§ 35. The Limit Idea Is Essential to a satisfactory definition of an instantaneous speed.

The distinction between an interval of time and an instant is like that between a line-segment and a point: an interval has some length or extent, but an instant has none. No distance whatever can be traveled “during an instant,” for an instant has no duration. Hence it would be meaningless to define an instantaneous speed as “the distance traveled

Generated for eJk6c (University of Virginia) on 2016-10-09 01:50 GMT / http://hdl.handle.net/2027/nyp.33433069104713 Public Domain, Google-digitized / http://www.hathitrust.org/access\_use#pd-google

during the instant divided by the length of time in the instant" (!).

Neither can we employ any such idea as "the speed during the shortest possible interval of time." There is no such thing: any interval, however short, has some definite extent, and can be subdivided into billions of still shorter intervals.\*

Again, it is useless to give any such vague definition of instantaneous speed as "the rate of motion at the instant." What is meant by the "rate at an instant" if the object doesn't move at this rate for even a short interval? This is precisely the thing to be defined.

Our definition of an instantaneous speed as the limiting value of an average speed is, however, definite, and free from logical objections. Many other familiar concepts can be defined satisfactorily only by using a similar idea.

**§ 36. Instantaneous Rates in General.** If we say that a balloon "is now expanding at the rate of 50 cu. ft. per min.," precisely what do we mean? Simply this:

The average rate of expansion for any short interval beginning now will be very approximately 50 cu. ft. per min.; and *the limiting value which this average rate would approach, if the interval were indefinitely shortened, is exactly 50 cu. ft. per min.*†

\* Large and small are purely relative terms. Select any number which you consider "small," and divide it by a billion. Repeat this division a hundred times; you then will have a number beside which the original "small" number is enormously great. But even your new number is very great compared with some others.

† Persons unfamiliar with this limit idea are generally unable to explain the precise meaning of such a statement as the one above concerning the balloon. For instance, they will often say: "This means that, if the balloon kept on just as it is now growing, it would expand by 50 cu. ft. in the next minute." (And so it would.) But precisely what is meant by "just as it is now growing"? What is meant by the way, or rate at which, the balloon is expanding at the instant? This is precisely the thing to be explained! Such an explanation merely leads around a circle, and explains nothing at all.



Similarly in general, when we speak of the rate at which any quantity is increasing "at a certain instant," we mean: the limiting value approached by the average rate in an adjoining interval, as the interval is indefinitely shortened.

To calculate an instantaneous rate, then, we simply get the average rate for an arbitrary adjoining interval, and see what happens to this as the interval is indefinitely shortened.

Ex. I. The volume ( $V$  cu. in.) of a certain weight of a gas varies with the pressure ( $p$  lb. per sq. in.) thus:

$$V = \frac{200}{p} \quad (2)$$

Find the rate at which  $V$  changes per unit change in  $p$ , at the instant when  $p$  reaches the value 17.

*Solution:*

At  $p = 17$ ,  $V = \frac{200}{17}$ .

At  $p = 17 + \Delta p$ ,  $V = \frac{200}{17 + \Delta p}$ .

The change in  $V$  due to the increase  $\Delta p$  is

$$\Delta V = \frac{200}{17 + \Delta p} - \frac{200}{17}$$

or, reducing to a common denominator and simplifying:

$$\Delta V = \frac{-200 \Delta p}{17(17 + \Delta p)}$$

The average rate of increase per unit is, therefore,

$$\frac{\Delta V}{\Delta p} = \frac{-200}{17(17 + \Delta p)}$$

The instantaneous rate is the limit approached by this as  $\Delta p$  approaches zero:

$$\text{Inst. rate} = -\frac{200}{17^2} = -.69, \text{ approx.}$$

That is, the volume is at the instant in question *decreasing* at the rate of .69 cu. in. per unit increase in  $p$ . (What shows that the volume is decreasing? Should that be expected?)

$$\begin{aligned} \Delta V &= \frac{200}{17 + \Delta p} - \frac{200}{17} \\ &= \frac{200}{17(17 + \Delta p)} - \frac{200}{17} \\ &= \frac{17(200) - 200(17 + \Delta p)}{17(17 + \Delta p)} \\ &= \frac{17(200) - 17(200) - 200\Delta p}{17(17 + \Delta p)} \\ &= \frac{-200\Delta p}{17(17 + \Delta p)} \end{aligned}$$

## EXERCISES

1. Explain briefly the precise meaning of the following statements. (Each necessarily involves the idea of a limiting value, approached as an interval is indefinitely shortened.)

(a) The ice is melting more and more slowly; just now it is melting at the rate of 1.75 cc. per sec.

(b) The diameter of the balloon increased as the temperature rose: the rate was .002 ft. per degree when the temperature had just reached 60°.

(c) The water in a basin was flowing out at the rate of 20 cu. in. per min. at the instant when it was 5 in. deep.

(d) The temperature of an iron bar was falling at the rate of 8° per min. at the instant when it reached 150°.

(e) A wound was healing at the rate of .04 sq. cm. per hr. just four days after the first treatment.

(f) The force exerted by steam against a piston was decreasing at the rate of 2000 lb. per ft. moved, when the piston had gone just 2 ft.

(g) Some salt was thrown into a pan of water; 30 sec. later it was dissolving at the rate of .3 oz. per sec.

[2.] Precisely what is meant by the "area" or "number of square feet" within a given curve? Such a space cannot be cut up exactly into square feet.

(3.) The distance ( $s$  ft.) that a ball had rolled down an incline after  $t$  sec. was  $s = 7t^2$ . How far had it rolled when  $t = 10$ ? When  $t = 10 + \Delta t$ ? What average speed from  $t = 10$  to  $t = 10 + \Delta t$ ? What if  $\Delta t = .0001$ ? Exactly what speed at the instant when  $t = 10$ ?

4. A ball rolled up an incline, its distance from the starting point after  $t$  sec. being  $s = 80t - 10t^2$ . What was its average speed from  $t = 2$  to  $t = 2 + \Delta t$ ? Its exact speed at  $t = 2$ ?

5. A bomb was dropped from an airplane. Its height above ground  $t$  sec. later was  $h = 5000 - 16t^2$ . Find the rate of fall at  $t = 10$ .

6. A square metal plate is heated and expands. Find the rate at which the area is increasing, per unit change in the edge  $x$  in., at the instant when  $x = 5$ .

7. Like Ex. 6 for a circular plate. Find the rate at which  $A$  is increasing, per unit change in the radius, when  $r = 6$ .

8. A volume of gas varied thus with the pressure:  $V = 500/p$ . Find how fast  $V$  was changing per unit change in  $p$  at the instant when  $p = 21$ .

9. The strength  $S$  of a beam is different for different thicknesses ( $x$  in.). If  $S = 9x^2$ , how fast does  $S$  change per unit increase in  $x$  at the instant when  $x = 10$ ?

10. As a rolling weight  $W$  moves along a beam, the "bending moment"  $B$  varies, being  $B = 6000 + 700x - 50x^2$  when  $W$  is  $x$  ft. from one end. Find how fast  $B$  is changing with  $x$  at the instant when  $x = 12$ .

§ 37. Length. Just what is meant by the "length" of a *curved line*, or the "distance" along a curve?

Consider how you would proceed to measure it approximately. Obviously you would measure only a small arc at a time, — which would be nearly straight and hence practically coincide with a part of your ruler. In reality, however, you would be measuring not the little arc itself but its *chord*.

The combined lengths of all the chords (Fig. 24) would approximate closely the thing which we call "the length of the curve." The latter we define, then, simply as the limiting value approached by the total length of the chords as their number is indefinitely increased and the length of each approaches zero.

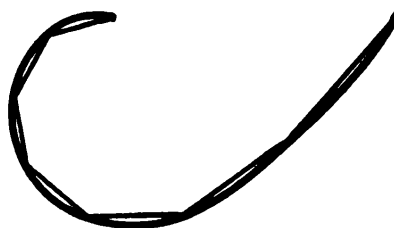

FIG. 24.

*E.g.*, we define the circumference of a circle as the limiting value approached by the perimeter of a regular inscribed polygon, when the number of sides is indefinitely increased.

*The limit idea is essential to a satisfactory definition.* Thus it would not do to say merely: "the length of a line is the number of inches it contains." A curved line cannot be cut up into parts each of which would coincide with an inch rule or some fraction thereof. The phrase, "the number of inches which it contains," is meaningless by itself. To speak of "the number of inches to which it is equivalent," would be no better. For what is meant by their being "equiva-

lent " other than that they " contain " the same number of inches?

Nor is it any definition to say that the "length of a curve is the length which it would have if straightened out." A geometrical curve must be taken as it is. So must the curved edge of a table, for instance.

Again, if we defined the length of a curve as the length of a rule which would roll along the curve from one end to the other without slipping, we should be presupposing an accurate definition of "rolling without slipping," — which would itself be found to involve the limit idea.

In fact, the idea of a limiting value is needed to define fully *even the length of a straight line segment*. *E.g.*, the side and diagonal of a unit square are incommensurable. The diagonal " contains " the unit an irrational number of times (*viz.*  $\sqrt{2}$  times); but this needs explanation, and sooner or later involves the idea of a limiting value.

**§ 38. Area and Volume.** By the "area" of a plane figure bounded by a curved line we mean the *limiting value* approached by the area of an inscribed polygon, as the number of sides is indefinitely increased, each side being indefinitely shortened.

The area of any plane figure can be approximated by dividing it into narrow strips and replacing each strip by a rectangle. (See Fig. 15, p. 29.) This same idea could be used in *defining* the area, — say as the limiting value approached by the sum of the rectangular areas, as each strip becomes indefinitely narrow.

The definitions of the area of a curved surface and the volume of a solid are somewhat similar, but more complicated.

### EXERCISES

1. Two runners, one with a long and the other with a short stride, run a quarter mile on a curved track. If their footsteps follow the same curved line, which steps the greater distance?

2. Draw a circle of radius 3 in., and measure its circumference approximately by rolling a ruler carefully along the circle. Also approximate its area by using rectangles. Check.

3. (a) On some map measure the approximate length of the shore of Lake Superior. (b) Likewise the length of the Mississippi River from Minneapolis to the Gulf.

4. Criticize the following "Explanation." To say that the volume of a sphere is 200 cu. ft. means that the sphere "contains" 200 cu. ft., or that the "amount of space" is the same as in 200 foot cubes.

[5.] What is meant by a tangent to a circle? Can you draw any sort of curve to which that definition of a tangent line would not apply? Can you suggest any definition which would always apply?

§ 39. **Instantaneous Direction.** A moving object usually travels along a curved path, and thus does not move in any one direction during even a small fraction of a second. What then is meant when we say that it "is now moving in a certain direction"?

The short arc  $PQ$  (Fig. 25) passed over in a short time is nearly straight, and hence nearly coincides with its chord. The direction of the chord or secant approximates

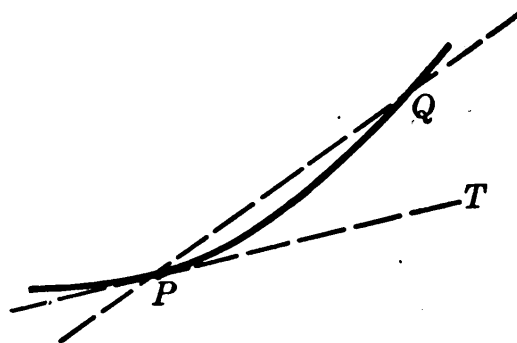

FIG. 25.

closely what we regard as the instantaneous direction of motion, — the shorter the time, the better.

The instantaneous direction of motion is simply the *limiting direction* of the secant, as the time-interval is indefinitely shortened.

It is often said that the direction of motion at any instant, or the direction of a curve at any point, is the direction of the tangent line. But why? Simply because the tangent line  $PT$  is the limiting position approached by the secant line  $PQ$ , as  $Q$  approaches  $P$  along the curve.

§ 40. **Definition of a Tangent Line.** The last statement above will be taken as our definition of a tangent to any curve. Memorize it.

The limit idea is essential. Various definitions sometimes given for a tangent to a circle are worthless for more complicated curves.

(1) For example, the idea that a tangent is "a line perpendicular to a radius" cannot be applied to either curve in Fig. 26, — unless we can say what constitutes a "radius" of such a curve. (Not even a short arc of one of these could be a part of a circle, because of the continual change of curvature.)

(2) The idea that a tangent is "a line meeting the curve at only one point" is unsound. For evidently  $AA'$  in Fig. 26 is not what we mean by a tangent, while  $BB'$  is clearly tangent at  $B$  although meeting the curve at several points.

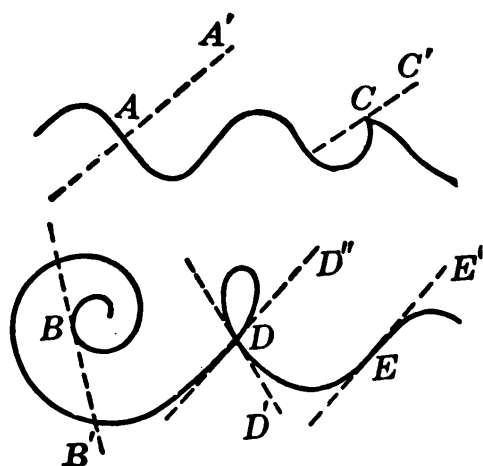

FIG. 26.

(3) The idea that a tangent is "a line touching the curve at a point without crossing it there," is also unsatisfactory. For instance  $CC'$  in Fig. 26 meets the curve at  $C$  without crossing it but is not what we mean by a tangent, — its direction differing from that of the curve at  $C$ , — while, on the other hand,  $EE'$  has the direction of the curve at  $E$ , and should be regarded as tangent though it crosses. (Would you hesitate to call  $EE'$  tangent if considering only the part of the curve to the right or left of  $E$  alone?)

The important question is not whether a line crosses a curve, but whether it has the *same direction* at the common point. Our definition of a tangent as the limiting position of a secant insures that the direction will be the same.

If different limiting positions are approached from the right and left, as at  $D$ , there are two tangents. If because of any peculiarity of the curve the secant fails to approach a limiting position, there is no tangent.

§ 41. **Slope or Grade.** To describe the rate at which a line or curve rises, per horizontal unit, we speak of its *slope* or *grade*.

In the case of a straight line, the slope is simply the number of units the line rises in each and every horizontal unit. If it rises 47 ft. in 100 ft. horizontally its slope is .47. Or its grade is 47%.

The slope of a horizontal line is zero. There is no such thing as the slope of a vertical line.

Of course a line may be very nearly vertical and yet have a slope. The slope increases without limit if the line approaches a vertical position indefinitely.

In the case of a curve we speak of the *average slope* in any interval, and also of the *slope at any point*.

By the average slope is meant the average rise per horizontal unit during the interval. (This would equal  $\Delta y/\Delta x$  in Fig. 27.) By the slope at any point  $P$  is meant the limiting value approached by the average slope  $\Delta y/\Delta x$  as  $\Delta x$  is indefinitely decreased.

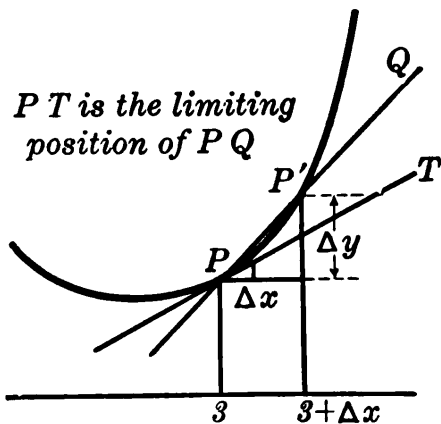

Observe in Fig. 27 that  $\Delta y/\Delta x$  is also the slope of the secant line  $PQ$ . Its limiting value is, therefore, the slope of the tangent line  $PT$ . Thus the average slope of a curve in any interval is the same as the slope of the secant; and the slope at any point is the same as the slope of the tangent  $PT$ .\*

Ex. I. The height ( $y$  ft.) of a certain suspension cable above its lowest point, at any horizontal distance ( $x$  ft.) from the center, is

$$y = .002 x^2.$$

Find the slope at the point where  $x=100$ .

\* See footnote, p. 15.

*Solution:* We first calculate the average slope in any interval, from  $x=100$  to  $x=100+\Delta x$ :

$$\begin{aligned} \text{At } x=100, & \quad y = .002 (100)^2 = 20; \\ \text{At } x=100+\Delta x, & \quad y = .002 (100+\Delta x)^2 = 20 + .4 \Delta x + .002\Delta x^2. \end{aligned}$$

The difference of the two heights,  $\Delta y = .4 \Delta x + .002 \Delta x^2$ , is the distance the cable rises in the horizontal distance  $\Delta x$ .

$$\therefore \frac{\Delta y}{\Delta x} = .4 + .002 \Delta x = \text{av. slope.}$$

Next we let the interval  $\Delta x$  become smaller and smaller, and see what *limiting value* is approached by this average slope. Evidently it is  $.4$ .

That is, the slope of the curve or of the tangent line at  $x=100$  is  $.4$ . Or the "grade" is 40%.

*Remark.* When a calculated slope comes out negative, it means simply that the curve is falling toward the right, inasmuch as the new value of  $y$  after  $x$  has increased is smaller than the original value which was subtracted from it. (Cf. Remark II, § 34.)

**§ 42. Drawing a Tangent.** Calculating the slope of a tangent line furnishes a means of drawing the line *exactly*.

*E.g.*, if the slope is  $.4$ , simply draw a line through the given point of tangency, rising  $.4$  units in each horizontal unit, toward the right. If the slope is  $-\frac{4}{3}$ , draw a line which falls toward the right  $\frac{4}{3}$  of a unit in each horizontal unit, — or, say, 4 units in any 3.

Whatever scales are used in plotting a curve are, of course, to be employed also in drawing any tangent line.

### EXERCISES

1. What is the slope of a line which rises 9 in. in each horizontal foot? 12 ft. in 30 ft. horizontally?
2. What is the grade of a sidewalk which rises 8 ft. in 50 ft. horizontally? Of a railroad which rises 132 ft. in 1 mi.?
3. Draw straight lines with these slopes:  $\frac{2}{3}$ ,  $-\frac{3}{2}$ ,  $-\frac{3}{5}$ ; also lines with these grades: 30%, 100%, 80% down grade.
4. The height of a certain hill ( $y$  ft.) varies with the horizontal distance ( $x$  ft.) from the foot, as in the following table. Plot the curve,



assuming it smooth. Measure the slope at  $x=200$  by drawing an apparent tangent line.

$x$	$y$	$x$	$y$
0	0	400	80
100	8	500	100
200	28	600	108
300	54		

5. Plot the graph of  $y=x^2$  from  $x=-3$  to  $x=3$ , using the same scales horizontally and vertically. Draw an apparent tangent at  $x=1$  and measure its slope. Also *calculate* exactly the rise of this curve from  $x=1$  to  $x=1+\Delta x$ . What average slope? What slope at  $x=1$ ? How could an exact tangent be drawn to this curve?

6. In Ex. 5 calculate also the slope at  $x=2$ . Draw a line having that slope.

7. Calculate the slope of the suspension cable in Ex. 7, p. 45, at the point where  $x=50$ . Show by drawing a line just how steep the cable is at that point.

8. The height of a curve  $x$  in. from a certain point horizontally is  $y=.8x-.05x^2$ . Find the slope at  $x=5$ .

9. Plot the graph of the function  $y=1/x$  from  $x=-3$  to  $x=6$ , using the same scale horizontally as vertically. Calculate the exact slope of the tangent line at  $x=3$ ; and draw the line having that slope, — thus checking your curve. (*N.B.* In getting the average slope from 3 to  $3+\Delta x$  it is necessary to subtract one fraction from another. How is this always done?)

§ 43. **A Gap in the Definitions.** We have defined instantaneous rates, slopes, lengths of curves, etc., as certain *limiting values*.

But it might conceivably happen in some cases that no limiting value would be approached. For example, a curve might be so full of sudden turns that a secant line through a given point would approach no definite limiting position while the interval was indefinitely shortened. There would then be no tangent line, nor any slope for the curve, at that point.

Our definitions will, therefore, be complete only when we can prove that the limiting values in question are actually being approached. To deal systematically with such questions, we shall now define explicitly what is meant by a "limiting value" or limit.

**§ 44. Limit Defined.** A variable  $v$  is said to approach a constant  $c$  as its limit (*written*  $v \rightarrow c$ ), if the difference between the variable and the constant will ultimately become and remain numerically less than any specified positive number, no matter how small.

To illustrate concretely, suppose that a weight suspended by an elastic cord is pulled down and released: the cord will contract, elongate, contract, etc. But the oscillations will become smaller; and the difference between the varying length of the cord and its original length will in time become and remain less than any small distance which we may specify. The variable length  $v$ , therefore, approaches the original length  $L$  as a limit:  $v \rightarrow L$ .

Again, more abstractly, suppose we have to deal with a quantity  $s = 15 + 80 \Delta x$ , as  $\Delta x$  is indefinitely decreased. Evidently  $s \rightarrow 15$ . For the difference between  $s$  and 15 is  $80 \Delta x$ , which in time will become and remain as small as we please.

Think of this as involving a contest. When I assert that  $s \rightarrow 15$ , I am saying that you may name any positive number you please, no matter how small, and that I can then prove that the difference between  $s$  and 15 will ultimately become and remain less than your specified number. *E.g.*, if you name .000 000 001, I must be ready to show that the difference between  $s$  and 15 will after some stage of the variation forever remain numerically less than this number. Otherwise I have no right to assert that  $s \rightarrow 15$ .

*N.B.* Whether a variable *reaches* its limit or not has nothing whatever to do with the question of its *approaching* a limit. The sole essential is that the difference between  $v$

and  $c$  shall after some stage of the variation remain numerically less than any specified positive number, however small.

§ 45. **A Doubtful Case.** The limiting value approached by any such ordinary expression as  $15 + 80 \Delta x$  while  $\Delta x \rightarrow 0$  seems obvious enough. But how about a quantity with very large coefficients, such as

$$q = 27 - 2\,000\,000 \Delta x + 2\,000\,000\,000 \Delta x^2?$$

Does this approach some limiting value? Is the limit 27?

Let us try smaller and smaller values of  $\Delta x$  and see what happens:

$\Delta x = .1,$	$q = 27 - 200\,000 + 20\,000\,000 = 19\,800\,027;$
$\Delta x = .01,$	$q = 27 - 20\,000 + 200\,000 = 180\,027;$
$\Delta x = .001,$	$q = 27 - 2\,000 + 2\,000 = 27;$
$\Delta x = .0001,$	$q = 27 - 200 + 20 = -153.$

These results suggest that  $q$  does not approach 27 finally. But let us go on.

For smaller values of  $\Delta x$ ,  $q$  has the values in the following table and approaches 27 closely. In fact

$\Delta x = .000\,000\,000\,001$  would make

$$q = 27 - .000\,002 + .000\,000\,000\,000\,002 = 26.999\,998 +.$$

$\Delta x$	$q$
.000 01	7.2
.000 001	25.002
.000 000 1	26.800 02
.000 000 01	26.980 000 2

Clearly by taking  $\Delta x$  small enough we could make both

$$2\,000\,000 \Delta x \text{ and } 2\,000\,000\,000 \Delta x^2 \tag{3}$$

as small as we please; and thus make  $q$  differ from 27 by less than any assigned positive number. That is,  $q \rightarrow 27$ .

If you desire to prove this *rigorously*, observe that as soon as  $\Delta x < .001$  numerically,\* the second term in (3) is the smaller. Hence the sum or difference of the two terms is surely less than twice the first, or  $4\,000\,000\,\Delta x$ . Hence if you assign any small positive number you please (call it  $e$ ), as soon as  $\Delta x$  is less than one four-millionth of  $e$ , the two terms in (3), or the difference between  $q$  and  $27$ , will be less than your number  $e$ . (*Q. E. D.*)

**§ 46. General Conclusions.** From the foregoing example it seems clear that any term containing  $\Delta x$ ,  $\Delta x^2$ , or  $\Delta x^3$ , etc., as a factor, will approach zero as  $\Delta x \rightarrow 0$ , no matter how large a coefficient it may have; also that the sum of any fixed number of such terms must approach zero. That is:

$$\begin{aligned} \text{(I)} \quad & k\Delta x^n \rightarrow 0, \\ \text{(II)} \quad & \pm a\Delta x \pm b\Delta x^2 \dots \pm k\Delta x^n \rightarrow 0 \end{aligned}$$

as  $\Delta x \rightarrow 0$ .

If a detailed proof of these two conclusions is desired, see p. 486 of the Appendix. We shall assume them correct in what follows.

**§ 47. Further Limit Notation.** To denote the limit which a quantity approaches as  $\Delta x \rightarrow 0$ , we shall write the symbol  $\mathbf{L}_{\Delta x \rightarrow 0}$  before the quantity. Thus  $\mathbf{L}_{\Delta x \rightarrow 0} (17\,\Delta x^2)$  stands for the limit of  $17\,\Delta x^2$  as  $\Delta x \rightarrow 0$ .

In this notation, statements (I) and (II) above may be re-written thus:

$$\begin{aligned} \text{(I)} \quad & \mathbf{L}_{\Delta x \rightarrow 0} (k\Delta x^n) = 0, \\ \text{(II)} \quad & \mathbf{L}_{\Delta x \rightarrow 0} (\pm a\Delta x \pm b\Delta x^2 \dots \pm k\Delta x^n) = 0. \end{aligned}$$

Still another notation is to write  $\lim$  in place of the  $\mathbf{L}$  above.

$$\text{(I)} \quad \lim_{\Delta x \rightarrow 0} (k\Delta x) = 0.$$

Also, the sign  $\doteq$  is often used in place of  $\rightarrow$ .

\*  $<$  means "is less than."

These notations should be studied until thoroughly familiar.

§ 48. **Functional Notation.** "Function" is often abbreviated  $f$ ; and the variable on which it depends is written after the  $f$ , in parentheses. Thus  $f(x)$  does not mean some quantity  $f$  times  $x$ , but some function of  $x$ , — read briefly " $f$  of  $x$ ." For instance,  $f(x)$  might stand for  $4x^3+7$ , or for  $10^x$ , etc.

The value of  $f(x)$  when  $x=3$  is denoted by  $f(3)$ . Thus if

$$f(x) = 2x^3 - 15x,$$

then 
$$f(3) = 2(3)^3 - 15(3) = 9.$$

The statement that "when  $x=3$  the function = 9" is summed up in the brief equation  $f(3) = 9$ .

To distinguish between different functions in the same problem, we denote them by  $f(x)$  and  $F(x)$ , or by  $f_1(x)$  and  $f_2(x)$ , etc.

### EXERCISES

1. In what sense can we say that a ball thrown straight upward is "instantaneously at rest" when it reaches the highest point, and not similarly "at rest" at other instants?

2. "The speed of a pendulum is neither increasing nor decreasing at the lowest point of the swing." Explain what this statement means, in view of the fact that the speed is *not constant* during any interval.

3. Exactly what is meant by saying that: As  $x$  approaches 2,  $(x^3+x-1)$  approaches 9 as a limit?

4. Tell in detail exactly what these statements mean:

(a)  $x^4 \rightarrow 16$  as  $x \rightarrow 2$ ,  
 (b)  $\mathbf{L}_{x \rightarrow 3} (x^2 - x + 5) = 11$ ,  
 (c)  $\lim_{\Delta x \rightarrow 0} (7 + 20 \Delta x + 3 \Delta x^2) = 7$ .

5. What is the numerical value of  $\mathbf{L}_{x \rightarrow 10} (x^3 - 7x^2 + 60x - 800)$ ? Of  $\lim_{x \rightarrow 2} \left( \frac{x^2 + 1}{x + 4} \right)$ ? Of  $\lim_{\Delta x \rightarrow 0} \left( \frac{20 + \Delta x}{5 - \Delta x} \right)$ ?

6. Point out precisely what is wrong with these notations:

(a)  $\lim_{x \rightarrow 0} (6+3x) \rightarrow 6$ , (b) As  $x \rightarrow 0$ ,  $(x^3+5) = 5$ .

7. (a) If  $f(x) = x^2 - 10x$ , find  $f(1)$ ,  $f(20)$ ,  $f(a)$ ,  $f(2.5)$ .

(b) If  $F(x) = x^3 + 5$ , find  $F(0)$ ,  $F(k)$ ,  $F(2 + \Delta x)$ ,  $F(3 + \Delta x)$ .

8. (a) Calculate the slope of the tangent to the graph of  $y = x^3$  at  $x = 2$ .

(b) The angle ( $A^\circ$ ) turned by a wheel after  $t$  sec. was  $A = t^3$ . Calculate the average speed of rotation from  $t = 2$  to  $t = 2 + \Delta t$ . Also the instantaneous speed when  $t = 2$ .

(c) The edge of a cube is increasing. Calculate the instantaneous rate of increase of its volume when the edge  $x = 2$ . Also the instantaneous rate when  $x = a$ , any value.

9. Find the slope of the curve  $y = 10x - x^2$  at  $x = 4$ ; and draw a line having that slope.

10. The repulsion ( $F$  dynes) between a certain pair of electrical charges varies thus with the distance ( $x$  cm.) apart,  $F = 10/x^2$ . Find how fast  $F$  changes with  $x$ , at  $x = 2$ . (See Ex. 9, p. 69, note.)

11. The speed ( $V$  ft./sec.) of an automobile  $t$  sec. after starting, and until the full speed was reached, varied thus:  $V = 4t - .1t^2$ . Find the rate at which the speed was increasing (*i.e.*, the *acceleration*) at  $t = 10$ .

**§ 49. Summary of Chapter II.** The idea of a limiting value is essential to a satisfactory definition of an instantaneous speed, slope or rate, tangent line, direction or length of a curve, area, or volume, etc. Moreover, each of these things should be defined *conditionally*.

*E.g.*, "if the average rate . . . approaches a limiting value . . . , this limit is called the instantaneous rate."

By formulating these definitions accurately, we see how to calculate the quantities in question. *E.g.*, to calculate an instantaneous rate, we must find what limit is approached by an average rate in an adjoining interval which is being indefinitely shortened.

We discover also that several apparently distinct problems, — such as finding the speed of a moving object, the slope of a curve, and the rate of expansion of a metal cube, — may in reality be one and the same problem. (Cf. Ex. 8, p. 74.) In fact, a single process will suffice for calculating all instantaneous slopes, speeds, and rates. And so, in the next chapter, we shall reduce this process to a system, whereby we can *write formulas for these quantities at sight*, and can use the formulas readily for many purposes.

Quite apart from their immediate utility, the limit concepts which we have been considering are a valuable possession for any one. If we realize their full import, and how constantly they occur in the affairs of daily life, we shall develop a very helpful point of view and a fine insight into the world about us.

Moreover, critical analysis such as we have attempted here, — the effort to get at the inner meaning of terms, — is the very essence of all accurate thinking. Much fruitless controversy would be avoided in daily life by insisting upon clear ideas and accurate definitions.

## CHAPTER III

### DIFFERENTIATION

#### SOME IMPORTANT PHASES OF THE RATE PROBLEM

**§ 50. Rate-formulas.** If we wish to know the speed of a moving object at several different instants, we can save time by deriving once for all a general *formula* for the speed at any instant whatever. Similarly for slopes and rates in general.

**Ex. I.** The height ( $y$  ft.) of a vertically thrown ball after  $t$  sec. was  $y = 100t - 16t^2$ . Find the speed at any instant.

We proceed as when calculating the speed at  $t = 3$  (§ 34), but do not specify a particular value for  $t$ .

At any instant,  $y = 100t - 16t^2$ .

$\Delta t$  sec. later,  $y = 100(t + \Delta t) - 16(t + \Delta t)^2$ .

Simplifying the latter value of  $y$  and subtracting the former gives \*

$$\Delta y = 100 \Delta t - 32t \Delta t - 16 \Delta t^2.$$

This difference in height is the distance traveled during the  $\Delta t$  sec.

$$\therefore \frac{\Delta y}{\Delta t} = 100 - 32t - 16 \Delta t.$$

This is the average speed during  $\Delta t$  sec. beginning at any time  $t$ . The limit approached by this as  $\Delta t \rightarrow 0$  is

$$\mathbf{L}_{\Delta t \rightarrow 0} \left( \frac{\Delta y}{\Delta t} \right) = 100 - 32t. \quad (1)$$

\*  $\Delta t$  will not combine with  $t$  as  $\Delta t^2$ , for it is not a product  $\Delta \cdot t$  but simply the *difference in*  $t$  or "increment" of  $t$ . (§ 25.)



This is the instantaneous speed at the beginning of our interval  $\Delta t$ ; *i.e.*, the speed at any time  $t$  sec. after the ball was thrown.

For instance :

$$\begin{array}{ll} \text{at } t=0, & \text{speed} = 100 - 32(0) = 100 \text{ (ft./sec.)} \\ \text{at } t=3, & \text{speed} = 100 - 32(3) = 4 \text{ (ft./sec.)} \end{array}$$

This last result was found in § 34. But now we can get the speed at any number of instants, by merely substituting values for  $t$  in (1).

From this speed-formula we can also find *exactly when the ball was highest*. For the speed was then exactly zero :

$$100 - 32t = 0. \qquad \therefore t = \frac{100}{32} = \frac{25}{8}.$$

At that instant,  $y = 100\left(\frac{25}{8}\right) - 16\left(\frac{25}{8}\right)^2 = 156\frac{1}{4}$ , — the greatest height.

### EXERCISES

1. A bomb was fired straight up, its height ( $y$  ft.) after  $t$  sec. being  $y = 360t - 16t^2$ . Find the speed at any time. In particular what speed at  $t = 10$ ? At  $t = 20$ ? When was the bomb highest? How high?

2. Plot the graph of  $y = x^3 - 6x$  from  $x = -4$  to  $x = 4$ . Calculate the exact slope at any point. In particular what slope at  $x = 1$  and  $x = 2$ ? Find the exact values of  $x$  at which  $y$  has its maximum and minimum (*i.e.*, turning) values.

3. A volume of gas ( $V$  cu. in.) varied thus with the pressure ( $P$  lb./sq. in.):  $V = 600/P$ . Find the rate of increase of  $V$  per unit change in  $P$  at any instant. What rate at  $P = 15$ ? At  $P = 20$ ?

4. As a ball rolled down an incline its distance ( $x$  ft.) from the top varied thus with the time ( $t$  sec.):  $x = 4t^2$ . Find the speed at any instant. What speed at  $t = 1, 2, 3, 4, 5$ ?

5. Calculate the slope of a suspension-cable curve, whose height is  $y = .003x^2$  at any point. What slope at  $x = 5, 20, 100$ ?

6. A spherical balloon expands as the temperature rises. Find the rate of increase of the volume, per unit change in the radius, at any time.\* What rate when  $r = 20$ ?

\* Formulas for volumes, etc., are given in the Appendix, p. 492.

§ 51. **Derivative of a Function.** Rate, slope, and speed calculations present one and the same problem. Let us, therefore, save time by formulating the problem abstractly in such a way as to cover all these calculations at once, — and perhaps others also.

Let  $y$  be any function of  $x$ . Then if  $x$  starts from any value and increases by any amount  $\Delta x$ ,  $y$  will increase by some  $\Delta y$  (positive or negative). If  $\Delta x$  is made very small,  $\Delta y$  will usually become very small also; but the fraction  $\Delta y/\Delta x$  will ordinarily approach some definite limiting value.

The limit of  $\Delta y/\Delta x$  as  $\Delta x$  approaches zero is called the *derivative of  $y$  with respect to  $x$* , and is denoted by  $dy/dx$ . That is,

$$\frac{dy}{dx} = \lim_{\Delta x \rightarrow 0} \left( \frac{\Delta y}{\Delta x} \right). \quad (2)$$

The notation  $dy/dx$  is read “ $d y$  over  $d x$ ”; but we are not using it to stand for some quantity  $dy$  divided by some quantity  $dx$ . We are using it simply as a notation for the limit approached by  $\Delta y/\Delta x$ .

Though a derivative is thus defined abstractly, yet it has many possible concrete interpretations, — and hence everything which we learn about derivatives will apply at once to many different problems. The definition and the following facts should therefore be learned with the greatest care.

§ 52. **Interpretations of  $dy/dx$ .** Some of the more fundamental interpretations of derivatives will now be mentioned.

(a) If  $y$  denotes the distance traveled by a moving object, and  $x$  denotes the time, then  $\Delta y$  = the additional distance traveled in an additional time  $\Delta x$ ; and

$$\begin{aligned} \frac{\Delta y}{\Delta x} &= \frac{\text{distance}}{\text{time}} = \text{average speed during } \Delta x; \\ \therefore \frac{dy}{dx} &= \text{limit of average speed} = \text{instantaneous speed.}^* \end{aligned}$$

\* Why could we not find this speed by simply dividing the distance  $y$  by the time  $x$ ?

(b) If  $y$  denotes the height of a graph and  $x$  the horizontal distance from a fixed point, then  $\Delta y$  = the rise in a small horizontal distance  $\Delta x$ ; and

$\frac{\Delta y}{\Delta x}$  = average slope of curve during interval  $\Delta x$ ;

$\therefore \frac{dy}{dx}$  = limit of average slope = slope at point  $P$ .



(c) If  $y$  denotes any quantity which varies with another,  $x$  (e.g., the volume of a fluid, with the temperature  $x$ ),  $\Delta y$  is the increase (in volume) produced by a rise of  $\Delta x$  (in temperature); and

$\frac{\Delta y}{\Delta x}$  = average rate of increase (cubic inches per degree).

$\therefore \frac{dy}{dx}$  = limit of average rate = instantaneous rate.

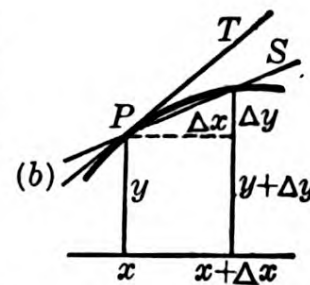

Thus the derivative  $dy/dx$  means instantaneous speed, slope, rate, etc., according to the meaning of  $x$  and  $y$ .

Always, in fact,  $dy/dx$  gives the instantaneous rate at which  $y$  is changing per unit change in  $x$ . Speed is simply the rate at which the traveled distance is increasing per hour (or second, etc.). Slope is the rate at which curve is rising per horizontal unit.

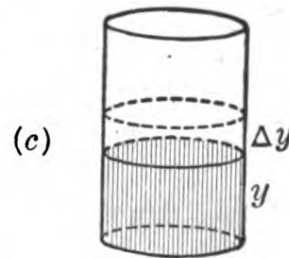

FIG. 28.

To find the rate at which any quantity is changing, simply get the derivative of the quantity.

**§ 53. Differentiation.** The process of calculating a derivative is called *differentiation*. It is the same as that of finding a formula for an instantaneous rate, speed, or slope; but is usually condensed as follows.

Ex. I. Differentiate  $y = x^3$ .

After  $x$  has increased, the new value of the function will be the original value  $y$  plus some increment  $\Delta y$ .

$$\begin{aligned} \therefore y + \Delta y &= (x + \Delta x)^3, \\ \text{i.e., } y + \Delta y &= x^3 + 3x^2\Delta x + 3x\Delta x^2 + \Delta x^3. \\ \therefore \Delta y &= 3x^2\Delta x + 3x\Delta x^2 + \Delta x^3. \\ \therefore \frac{\Delta y}{\Delta x} &= 3x^2 + 3x\Delta x + \Delta x^2. \\ \therefore \frac{dy}{dx} &= 3x^2. \end{aligned}$$

Observe that we get the final value,  $dy/dx$ , not by putting  $\Delta x = 0$  (which would make  $\Delta y/\Delta x$  meaningless), but rather by seeing *what limit  $\Delta y/\Delta x$  approaches as  $\Delta x \rightarrow 0$ .*

The resulting derivative, just obtained, may be given various concrete interpretations:

1. If  $y$  is the distance traveled by an object in any time  $x$ , and  $y = x^3$ , then the *speed* at any instant is  $3x^2$ .
2. If  $y$  is the height of a graph at any horizontal distance  $x$  from some fixed point, and  $y = x^3$ , then the *slope* at any point is  $3x^2$ .
3. If  $y$  and  $x$  are the volume and edge of a metal cube which is being heated, then  $y = x^3$ , and the rate of increase of the volume per unit change in the edge is at every instant equal to  $3x^2$ .

**§ 54. Increasing or Decreasing?** We shall often need to test whether a given function  $y = f(x)$  is increasing or decreasing at a particular value of  $x$ . To be definite, let  $x$  itself always increase.

Now the graph of a function is rising at any point where its slope is positive, and falling where its slope is negative. (Cf. Remark, § 41.) That is,

$$\begin{aligned} y \text{ is increasing where } dy/dx &= +, \\ y \text{ is decreasing where } dy/dx &= -. \end{aligned} \tag{3}$$

*Remarks.* (I)  $y$  may be increasing or decreasing even at points where  $dy/dx = 0$ , — that is, where the slope is zero. (Discussed later: § 64.)

(II) It is not a sure test of increasing to compare the value of  $y$  at the given point with some near-by value. For  $y$  might be increasing at the point, and yet have decreased before reaching the comparison value.

But the test given in (3) above is sure. For if  $\Delta y/\Delta x$  is *ultimately* positive, the neighboring point must ultimately be the higher, and hence  $y$  must be increasing.

## EXERCISES

1. Differentiate the following functions :

- |                       |                          |                  |
|-----------------------|--------------------------|------------------|
| (a) $y = x^2,$        | (b) $y = x^3,$           | (c) $y = x^4,$   |
| (d) $y = 3x^2 - 9,$   | (e) $y = x^2 - 9x + 10,$ | (f) $y = 7/x,$   |
| (g) $y = 70t - 5t^2,$ | (h) $y = t^2 + 100/t,$   | (i) $y = 10t^3.$ |

Test whether each of these functions is increasing or decreasing at  $x = 1$  (or  $t = 1$ ).

2. A ball rolled up an incline so that its distance from the starting point after  $t$  sec. was  $y = 70t - 5t^2$ . By Ex. 1 (g) what was the speed at  $t = 0, 2, 8$ ? When was it farthest up, and how far?

3. Plot  $y = x^2 - 9x + 10$  from  $x = 0$  to  $x = 7$ . By Ex. 1 (e) what is the exact slope at  $x = 2$ ? At  $x = 5$ ? (Check.) Exactly what  $x$  gives the minimum  $y$ ? How small a value?

4. If  $y$  denotes the *speed* of a moving object and  $x$  the *time*, what is the meaning of  $\Delta y/\Delta x$ , and of  $dy/dx$ ?

5. If the speed of a car  $t$  sec. after starting was  $V = 4t - .2t^2$ , what was the *acceleration* at any time? (Cf. Ex. 9, p. 24, note.) What at  $t = 0, 5, 10, 15$ ?

6. Along an arch of a bridge the height ( $y$  ft.) above the water at any horizontal distance ( $x$  ft.) from the center is  $y = 70 - .006x^2$ . Find the slope at any point, and in particular at  $x = 50$ .

7. For the beam in Ex. 9, p. 63, find how fast the strength  $S$  will vary with the thickness  $x$  in. at any value of  $x$ , and in particular when  $x = 10$ .

8. The repulsion ( $R$  dynes) between a certain pair of electrical charges varies thus with their distance apart ( $x$  cm.):  $R = 20/x^2$ . Find how fast  $R$  changes with  $x$  in general. In particular how fast at  $x = 2$ .

[9.] Compare the results in Ex. 1 (a), (b), (c), above. What would you expect for  $dy/dx$ , if  $y = x^5$ ? If  $y = x^{10}$ ? If  $y = x^n$ ?

§ 55. **Power Laws.** In nature it is very common for one quantity ( $y$ ) to vary as some fixed power of another ( $x$ ), say

$$y = kx^n. \quad (4)$$

Such quantities are said to "vary according to the *Power Law*."

To study their rates of increase advantageously, we shall now obtain a formula for differentiating any power at sight.

§ 56. **Differentiating  $x^n$  by Rule.**

The adjacent table shows the derivatives of three powers of  $x$ , as found in Ex. 1, p. 81. These results suggest that the derivative of any positive integral power  $x^n$  would be  $nx^{n-1}$ . Let us see.

$y$	$dy/dx$
$x^2$	$2x$
$x^3$	$3x^2$
$x^4$	$4x^3$

If  $y = x^n$ , then  $y + \Delta y = (x + \Delta x)^n$ .

Multiplying out,  $(x + \Delta x)^n$  would always give

$$(x + \Delta x)^n = x^n + nx^{n-1} \Delta x + (\text{terms with } \Delta x^2, \Delta x^3, \text{ etc.})^*$$

Subtracting  $y = x^n$  and dividing through by  $\Delta x$  gives

$$\frac{\Delta y}{\Delta x} = nx^{n-1} \dots + (\text{terms with } \Delta x, \Delta x^2, \text{ etc.}).$$

The limit of this as  $\Delta x \rightarrow 0$  is simply  $nx^{n-1}$ . (§ 46, II.)

Thus 
$$\frac{dy}{dx} = nx^{n-1}. \quad (5)$$

In words: the derivative of any positive integral power of  $x$  equals the exponent of the given power, times the next lower integral power of  $x$ .

\* If not familiar with the Binomial Theorem, you can check this expansion as follows.  $(x + \Delta x)^n$  means  $(x + \Delta x) \cdot (x + \Delta x) \cdot (x + \Delta x) \cdot (x + \Delta x) \dots$  to  $n$  factors. Multiplying together the  $x$ 's of all the  $n$  factors gives  $x^n$ . Multiplying the  $\Delta x$  in any one factor by the  $x$ 's in all the others gives  $x^{n-1} \Delta x$  — and this term will occur  $n$  times in all when we use the  $\Delta x$  of one factor after another. Multiplying the  $\Delta x$ 's in two or more factors gives terms containing  $\Delta x^2$  or  $\Delta x^3$ , etc. — whose coefficients we do not need to know.

By this remarkable rule, we may write certain derivatives at sight. Thus

$$\text{if } y = x^6, \quad \text{then } \frac{dy}{dx} = 6 x^5;$$

$$\text{if } y = x^{100}, \quad \text{then } \frac{dy}{dx} = 100 x^{99}.$$

Memorize carefully the verbal statement of rule (5), and that of each similar rule that follows.

*N.B.* An important special case is the derivative of  $x$  itself:

$$\text{if } y = x, \quad \frac{dy}{dx} = 1 \cdot x^0 = 1.*$$

This result may also be obtained directly. Thus

$$\begin{array}{ll} \text{if } y = x, & \text{then } y + \Delta y = x + \Delta x. \\ \therefore \frac{\Delta y}{\Delta x} = 1, & \text{and } \frac{dy}{dx} = 1. \end{array}$$

This means that the rate at which  $y$  increases, per unit change in  $x$ , is 1, — which is obvious, since  $y = x$ .

**§ 57. Effect of a Constant Multiplier.** What will be the derivative of a power of  $x$  which is multiplied by some constant  $k$ ?

If  $y = kx^n$ , then  $y + \Delta y = k(x + \Delta x)^n$ .

Every term in the expansion is multiplied once by the factor  $k$ . Hence  $\Delta y/\Delta x$  is precisely  $k$  times as large as if we were differentiating  $x^n$  alone, and must approach a limit, or derivative, just  $k$  times as large.

*A constant multiplier  $k$  simply multiplies the derivative by  $k$ .*

$$\text{Ex. I.} \quad \text{If } y = 10 x^3, \quad \frac{dy}{dx} = 10(3 x^2) = 30 x^2.$$

This means simply that  $10 x^3$  increases just ten times as fast as  $x^3$ .

$$\text{Ex. II.} \quad \text{If } y = -\frac{1}{3} x^8, \quad \frac{dy}{dx} = -\frac{1}{3} (8 x^7) = -\frac{8}{3} x^7.$$

$$\text{Ex. III.} \quad \text{If } y = 17 x, \quad \frac{dy}{dx} = 17 (1) = 17.$$

\* For the meaning of a zero exponent, if unfamiliar, see § 67.

## EXERCISES

1. Differentiate the following functions at sight, writing the functions and their derivatives in parallel columns, like a table:

$$x^{20}, \quad 5x^4, \quad \frac{7}{3}x^6, \quad -8x, \quad .002x^5, \quad -.75x^8, \quad kx^{15}, \quad \frac{2}{3}x, \quad \frac{6x^{11}}{7}, \quad \frac{-x^3}{12}.$$

2. The same as Ex. 1 for the following, differentiating with respect to the variable named in each case:

$$.5t^3, \quad -9t^2/64, \quad 20t, \quad r^4, \quad -7v^2, \quad \pi r^2, \quad \frac{4}{3}\pi r^3.$$

3. The range of a certain gun for various muzzle velocities is  $R = .02V^2$ . How fast does  $R$  increase with  $V$  at  $V = 1200$ ?

4. In Ex. 3 plot  $R$  from  $V = 800$  to  $V = 1500$ , and check the calculated rate.

5. Find how fast the volume of a cube increases with the edge  $x$  in., when  $x = 20$ .

6. The distance ( $D$  ft.) required for stopping an auto under normal conditions varies as the square of the speed ( $V$  mi./hr.). If  $D = 20.7$  when  $V = 15$ , write the formula, giving  $D$  for any  $V$ . Also find how fast  $D$  increases with  $V$  at  $V = 20$ .

7. Find the derivatives of the following quantities. Substitute some numerical value and interpret each result as a statement about rates.

(a) The distance a ball had fallen after  $t$  sec. was  $s = 16t^2$ .

(b) The speed of a falling object after  $t$  sec. was  $v = 32t$ .

(c) The kinetic energy of a moving car was  $E = 25v^2$ .

(d) The height of a suspension cable  $x$  ft. from the middle is  $y = .004x^2$ .

(e) When a certain locomotive rounds a certain curve at a speed of  $V$  mi./hr., the centrifugal force ( $F$  tons) is  $F = .09V^2$ .

(f) The consumption of coal ( $C$  tons/hr.) in a certain locomotive varies thus with the speed ( $V$  mi./hr.):  $C = V^2/162$ .

**§ 58. Effect of an Added Constant.** How does a constant which is added to a function affect the derivative?

$$\text{If } y = f + k, \text{ then } y + \Delta y = (f + \Delta f) + k.$$

Obviously  $k$  drops out in subtracting to get  $\Delta y$ . Thus  $\Delta y/\Delta x$ , and hence  $dy/dx$ , has the same value as if we were differentiating  $y = f$  alone. That is, a constant added to a function contributes nothing to the derivative.



Ex. I. If  $y = x^4 + 1000$ ,  $\frac{dy}{dx} = 4x^3$ .

This means that  $(x^4 + 1000)$  increases at the same rate as  $x^4$ .

Graphically speaking, adding a constant to a function simply raises or lowers the entire graph by a fixed amount, and does not change the *slope* at any point.

The derivative of an isolated constant is zero, since its rate of change is zero. *E.g.*,

$$\text{if } y = 2^{10} \text{ continually, } \frac{dy}{dx} = 0.$$

§ 59. **Differentiating a Sum.** If  $y$  is the sum of two functions of  $x$ , say  $y = f + F$ , and if  $x$  increases by  $\Delta x$ , then

$$y + \Delta y = f + \Delta f + F + \Delta F.$$

$$\therefore \frac{\Delta y}{\Delta x} = \frac{\Delta f}{\Delta x} + \frac{\Delta F}{\Delta x}.$$

$$\therefore \frac{dy}{dx} = \frac{df}{dx} + \frac{dF}{dx}.$$

That is, the derivative of the sum of two functions is simply the sum of their separate derivatives.

The same is evidently true for the sum of any specified number of terms.

Ex. I. If  $y = x^{17} + 4x^{10}$ ,  $\frac{dy}{dx} = 17x^{16} + 40x^9$ .

Ex. II. If  $y = \frac{5}{3}x^8 - 15x + 4$ ,  $\frac{dy}{dx} = \frac{40}{3}x^7 - 15$ .

We can now write at sight the derivative of any "polynomial," and use it to solve problems on rates, slopes, etc.

### § 60. Differentiating a Product or Fraction.

Ex. I. Differentiate  $y = (x^2 + 6)(x^3 - 4)$ .

Multiplied out:  $y = x^5 + 6x^3 - 4x^2 - 24$ .

Differentiated:  $\frac{dy}{dx} = 5x^4 + 18x^2 - 8x$ .

Could this result be obtained by differentiating the factors  $(x^2+6)$  and  $(x^3-4)$  separately, and then multiplying the two derivatives  $2x$  and  $3x^2$  together?

Ex. II. Differentiate  $y = \frac{x^3+72}{x}$ .

Divided out:  $y = x^2 + \frac{72}{x}$ .

Since we have as yet no rule for terms with  $x$  in the denominator, we resort to the "Δ-process" (§ 53); and get finally

$$\frac{dy}{dx} = 2x - \frac{72}{x^2}.$$

This result cannot be obtained by differentiating the numerator and denominator separately.

These examples show that *the derivative of the product or quotient of two functions is NOT equal to the product or quotient of the two derivatives*. At present we can differentiate a fraction only by the "Δ process" and a product only by that process or by first multiplying out.

### EXERCISES

1. Differentiate, writing the results in tabular form:

$x^2+5,$	$x^4-3x,$	$x^8-2x^5+x,$	$\frac{1}{2}x^9-6x+10,$
$.1x^4+2^8,$	$.03x^2-\frac{x}{7},$	$\frac{x^3}{5}+x-10^5,$	$\frac{7}{2}x^4+\frac{x^3}{9}-\sqrt{7}.$

2. The same as Ex. 1 for the following, in which  $a$ ,  $b$ , and  $c$  denote constants:

$x^3+ax^2-bx+c;$	$\frac{5ax^6+2x^4}{3} + \frac{2x^4}{b};$	$\frac{5x^2-11c}{4} - \frac{11c}{3};$	$\pi x^2.$
------------------	--	---------------------------------------	------------

3. Differentiate:

(a)  $20x^2(9-x);$       (b)  $(x^3-1)(x^2+2x+5);$       (c)  $(3x^2-5)^2.$

4. The speed of a car  $t$  sec. after starting was  $V = .09t^2 - .001t^3$ . Find the acceleration at  $t = 40$ .

5. The height ( $y$  ft.) of a ship's deck, going forward from a certain point  $A$ , varies as the square of the horizontal distance ( $x$  ft.) from  $A$ . If  $y = 5.6$  when  $x = 200$ , find the formula for  $y$  at any  $x$ . Find the slope of the curve at  $x = 100$ .

6. The volume ( $V$  cu. ft.) of a certain ship's hull up to a height of  $x$  ft. above the keel is  $V = 1600x^2 - 80x^3 + 2x^4 - .02x^5$ . Find how fast the volume of water displaced increases with the draught (*i.e.*, how fast  $V$  increases with  $x$ ) at  $x = 10$ ; at  $x = 20$ .

7. The momentum of a locomotive  $t$  min. after starting was  $M = 2t^2(t - 20)^2$ . Find how fast  $M$  was changing at  $t = 5$  and at  $t = 15$ . Increasing or decreasing?

8. Plot  $y = 30x - x^3$  from  $x = -3$  to  $x = 6$ . Calculate the exact rate of increase of  $y$  at  $x = -2$  and  $+2$ . Compare the graph. Is  $y$  increasing or decreasing at  $x = 3$ ? Make a sure test.

9. Plot  $y = x^3 + 5$  from  $x = -3$  to  $x = 3$ , calculating  $y$  at  $x = \frac{1}{2}$ ,  $-\frac{1}{2}$ . Calculate the exact slope at  $x = 0$  and  $1$ . Compare the graph.

10. (a) Plot  $y = .8x + 3$  from  $x = 0$  to  $x = 10$ . Measure its slope; and calculate the same by differentiation.

(b) Prove that the graph of any linear function  $y = ax + b$  has a constant slope. Hence what sort of graph? [Cf. § 7, Fig. 10.]

11. (a) Plot  $y = x^2$  and also  $y = x^2 + 3$ , over the same base line, from  $x = 0$  to  $x = 4$ . Compare the slopes at any value of  $x$  by measurement. Then find  $dy/dx$  in each case and compare.

(b) Likewise plot  $y = .7x^2$  over the same base line as in (a) and compare its slope with that of the curve  $y = x^2$ .

12. The following equations give the approximate percentage change ( $y$ ) in the price of various farm products for any percentage change ( $x$ ) in the size of the crop.\*

(a)  $y = .94 - 1.0899x + .02391x^2 - .000234x^3$ . (Corn.)

(b)  $y = 8.22 - 1.1904x - .00663x^2 + .000273x^3$ . (Oats.)

(c)  $y = 1.77 - 1.5062x + .02489x^2 - .000197x^3$ . (Potatoes.)

In each case find  $dy/dx$  when  $x = 10$  and when  $x = 0$ . (The latter value is related to the "coefficient of elasticity of demand," — discussed in Economics.)

13. Differentiate  $y = (x^3 + 5x^2 + 3)/x$ .

(Hint: Divide out; then differentiate by the  $\Delta$ -process, § 53.)

14. The same as Ex. 13 for  $y = (x^4 - 7x^2 + 11)/x^2$ .

15. (a)–(e). Write at sight the rates, slopes, etc., called for in: Exs. 9–10, p. 63; Ex. 8, p. 69; Exs. 5–6, p. 77.

[16.] The force ( $F$  lb.) applied to an object varied thus with the time ( $t$  min.):  $F = 40t - t^2$ . Find how fast  $F$  was increasing at  $t = 10$ . Hence, about how much did  $F$  increase in the next .02 min.?

17. In Ex. 16 was  $F$  increasing or decreasing at  $t = 21$ ?

\* See H. L. Moore: *Economic Cycles*.

**§ 61. Note on Mensuration Formulas.** A ready command of the elementary formulas for volumes, areas, etc., is essential in what follows. Recalling certain facts which are proved in geometry may help to fix those formulas in mind.

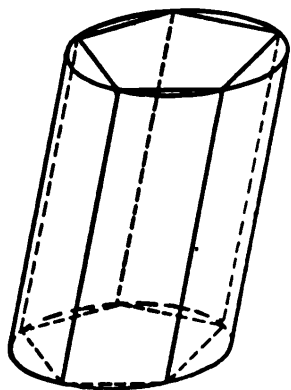

FIG. 29.

(I) An area is always the product of *two* linear dimensions, while a volume is the product of *three*. Thus a volume formula could never be  $2\pi rh$ , say.

(II) *The same formulas apply to cylinders as to prisms.* The reason is that a cylinder is the limiting form approached by an inscribed prism, when the number of sides of the base is indefinitely increased. For either solid:

$$\text{Volume} = (\text{area of base}) \times (\text{height}).$$

*N.B.* "Height" means the perpendicular distance between bases.

(III) *The same formulas apply to cones as to pyramids,* a cone being the limiting form approached by an inscribed pyramid. For either solid:

$$\text{Volume} = \frac{1}{3} (\text{area of base}) \times (\text{height}).$$

$$\text{Lateral area} = \frac{1}{2} (\text{perimeter of base}) \times (\text{slant height}).$$

The term "slant height" is meaningless, however, unless the cone is a right circular cone and the pyramid is regular.

(IV) *The area and volume of a sphere are*

$$A = 4\pi r^2, \quad V = \frac{4}{3}\pi r^3.$$

That is, the area exactly equals four "great circles" cut through the center, — a very surprising fact.

The volume equals one third the area times the radius, — just as if the sphere were composed of tiny pyramids with their vertices at the center and their bases in the surface.

(V) *The area and circumference of a circle are*

$$A = \pi r^2, \quad \text{and} \quad C = 2\pi r.$$

If you tend to forget these, study Fig. 30 carefully until you get the real significance of the formulas.



FIG. 30.

Obviously the area is less than  $4r^2$  and more than  $2r^2$ ; apparently about  $3r^2$ . Exact value:  $\pi r^2$ ; or  $3.1416r^2$ , very closely.

Each side of hexagon =  $r$ . Circumference is obviously a little more than  $6r$ . Exact value:  $2\pi r$ ; or  $6.2832r$ , very closely.

## EXERCISES\*

1. Exactly how does the curved surface of a hemisphere compare in area with the flat side?
2. If a square is circumscribed about a circle, approximately what percentage of the square is contained in the circle?
3. The same as Ex. 2 for a cube circumscribed about a sphere.
4. If a circle is inscribed in each face of the cube in Ex. 3, except the top and bottom, how does the combined area of these circles compare with the area of the sphere?
5. If a cylinder and cone have the same base and height, how do their volumes compare?
6. If a cylinder is circumscribed about a sphere (including the bases), what fraction of the cylinder is contained in the sphere?

**§ 62. Approximate Increments.** For a small interval  $\Delta x$ , the fraction  $\Delta y/\Delta x$  and its limit  $dy/dx$  are nearly equal. *I.e.*, approximately,

$$\frac{\Delta y}{\Delta x} = \frac{dy}{dx}, \quad \text{or} \quad \Delta y = \left(\frac{dy}{dx}\right) \Delta x. \quad (6)$$

Hence we can find the approximate change in  $y$ , due to a small change in  $x$ , by simply multiplying the derivative by  $\Delta x$ .

\* Hereafter when we speak of a "cylinder" or "cone" we shall mean a right circular cylinder or cone, unless something is said to the contrary.

Ex. I. If  $y = x^{10}$ , how much will  $y$  increase when  $x$  changes from 2 to 2.003?

Here  $\frac{dy}{dx} = 10x^9 = 5120$  at  $x = 2$ .

$$\therefore \Delta y = \left(\frac{dy}{dx}\right)\Delta x = (5120).003 = 15.36, \text{ approx.}$$

To find  $\Delta y$  *exactly* we should have to calculate  $y + \Delta y = (2.003)^{10}$  and subtract  $y = 2^{10}$ . This tedious operation gives  $\Delta y = 15.464 \dots$ , nearly the same as the approximation obtained so easily above.

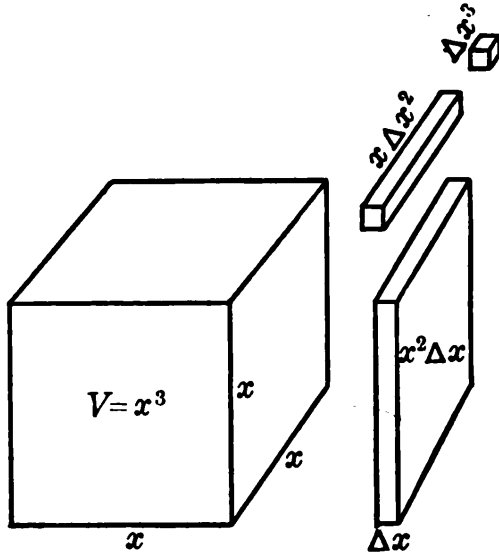

FIG. 31.

Ex. II. The edge of a cube was measured as 20 in. but was really 19.98 in. About how much was the calculated volume in error?

The question amounts to this: By how much would the volume change, if the edge changed from 19.98 to 20 in.?

$$V = x^3,$$

$$\therefore \frac{dV}{dx} = 3x^2 = 1200 \text{ at } x = 20.$$

$$\therefore \Delta V = \left(\frac{dV}{dx}\right)\Delta x = (1200).02 = 24, \text{ approx.}$$

The error in the calculated volume was about 24 cu. in.

This result would be affected very little by taking the value of  $dV/dx$  at  $x = 19.98$  instead of  $x = 20$ . We chose the simpler value.

Compare the approximate formula  $\Delta V = 3x^2\Delta x$  with Fig. 31.

### EXERCISES

1. If  $y = 7x^2$ , approximately how much does  $y$  increase while  $x$  increases from 9.98 to 10.03? Exactly how much?

2. If  $y = x^5 - 4x^3 + 11x - 17$ , approximately what change in  $y$  when  $x$  increases from 2 to 2.005?
3. In Ex. 2 about how much must  $x$  increase (starting from  $x = 2$ ) to change  $y$  by .04?
4. If a metal cube expands so that its edge  $x$  increases from 10 in. to 10.002 in., approximately what change in its volume? In its total area?
5. In Ex. 4 approximately what change in  $x$  would increase the volume by .45 cu. in.? The area by .3 sq. in.?
6. Find the approximate change in :
- (a) The area of a square if its edge increases from 8.47 in. to 8.52 in.
- (b) The circumference and area of a circular plate if the radius increases from 3.99 ft. to 4.01 ft.
- (c) The volume and area of a ball-bearing if it wears down from a radius of 5 mm. to one of 4.98 mm.
7. About what change would be necessary in :
- (a) The radius of a spherical balloon, to increase the volume by 10 cu. ft., if the radius is approximately 20 ft.?
- (b) The radius of a cylinder, to increase the volume by 4 cu. ft., if the height is constantly 20 ft. and  $r$  is about 3 ft.?
8. Approximately what errors will there be in the calculated
- (a) Area of a sphere if the radius is measured as 10 in. when its true value is 10.03 in.?
- (b) Volume of a cube if the edge is measured as 8 in. instead of 7.985, the true value?
- (c) Area of a circle if the *diameter* is measured as 40 in. instead of 40.06 in.?
9. Approximately what errors would be allowable in the measured
- (a) Side of a square (about 10 cm.), if the error in the calculated area is not to exceed .25 sq. cm.?
- (b) Diameter of a sphere (about 80 cm.), if the calculated volume is not to be in error by more than 100 cc.?
10. In Exs. 8-9 what is the approximate percentage error in each case?
11. In Ex. 3, p. 84, about how much greater a range is obtained if  $V = 801.1$  than if  $V = 800$ ?
12. In Ex. 7 (f), p. 84, about how much more coal is required per hour if  $V = 20.05$  than if  $V = 20$ ? Exactly how much?
13. The maximum deflection of a beam varies as the cube of the

length. If  $D = .4$  when  $l = 10$ , write a formula for  $D$ . Approximately how much larger is  $D$  for  $l = 12.08$  than for  $l = 12$ ?

14. The cost ( $y$  cents per hr.) of running a certain car at a speed of  $V$  mi./hr. varies thus:  $y = .3 V^2$ . Approximately how much will  $y$  increase while  $V$  increases from 20 to 20.6? Exactly how much?

[15.] Criticize this "proof" that  $1 = 2$ : When  $x = 1$ ,  $x^2 - x = x^2 - 1$ . Hence, factoring out  $x - 1$ :  $x = x + 1$ . That is,  $1 = 2$ .

**§ 63. Note on Zero Factors.** A principle of algebra much used in what follows is this: *A product is zero if any one of its factors is zero*; and, conversely, a product can be zero *only if* some factor is zero.

Ex. I.  $5x^2(x-4)(x+2) = 0$ .

This equation is satisfied if  $x^2 = 0$ , or  $(x-4) = 0$ , or  $(x+2) = 0$ , — that is, if  $x = 0, 4$ , or  $-2$ . And it can be satisfied by no other values.

This equation is the factored form of the equation

$$5x^4 - 10x^3 - 40x^2 = 0.$$

If we were solving the latter, and canceled out  $5x^2$ , we should lose the root  $x = 0$ , — one out of three possible values.

The indiscriminate canceling of factors may easily lead to an erroneous conclusion.

For instance, we might infer from the equation  $kx = 17x$  that  $k = 17$  necessarily, — which is not so;  $k$  might be 1000, or any other number. For if  $x$  happens to be zero,  $kx = 17x$ , no matter what value  $k$  has.

We can, however, assert that, since  $kx - 17x = 0$ ,

$$\therefore (k - 17)x = 0.$$

And hence, *either*  $x = 0$ , *or else*  $k - 17 = 0$  (making  $k = 17$ ).

*Never cancel a factor out of an equation without considering the possibility of its being zero.*

**§ 64. Horizontal Tangents.** Any graph has a horizontal tangent wherever its slope  $dy/dx = 0$ . Usually it is then turning from rising to falling or vice versa, — as at  $A$  or  $B$  in Fig. 32.



But not always. *E.g.*, in the graph of  $y=x^3$  (Fig. 33), the slope  $dy/dx(=3x^2)$  is zero at  $x=0$ : but the curve rises through  $C$ , being lower everywhere to the left and higher everywhere to the right.

A sure test as to whether there is a turning point can be made by noting the *sign of  $dy/dx$*  near by. Thus if the sign

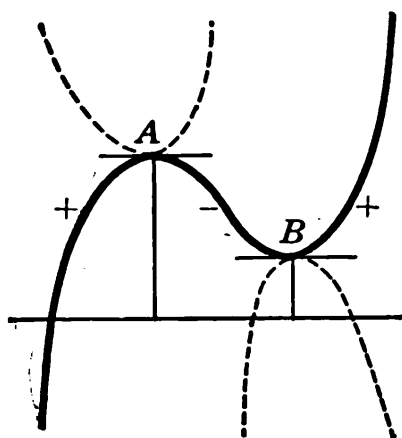

FIG. 32.

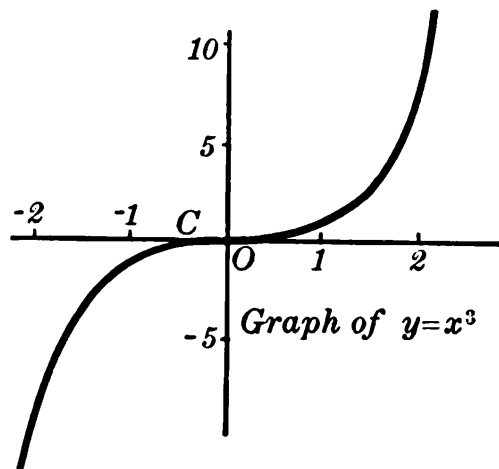

FIG. 33.

runs  $+ - +$  as in Fig. 32, the curve must rise to  $A$ , fall to  $B$ , and then rise again.

*N.B.* This curve to the left of  $A$  is regarded as a rising rather than a falling curve, because we always think of *going toward the right, with  $x$  increasing*.

### EXERCISES

1. What sure conclusion as to the value of  $x$  can you draw from each of the following equations:

(a)  $x^2=20x?$

(b)  $2\pi^2x^2=15\pi x?$

(c)  $\pi x^2(10-x)=0?$

2. Plot each of the following curves, at least through the interval indicated. Show clearly all horizontal tangents, and all intersections with the base line.

(a)  $y=11x-x^2,$

$-2$  to  $+12;$

(b)  $y=5-x^3,$

$-2$  to  $+4;$

(c)  $y=x^4-4x^2+10,$

$-3$  to  $+3;$

(d)  $y=x^4-4x^3+10,$

$-3$  to  $+5.$

§ 65. **Extreme Values.** As any ordinary (rational algebraic) function  $y$  approaches a maximum or minimum value, its graph rises or falls very slowly. At the turning point, the slope is zero.

By using this latter fact, we can locate the extreme values (maxima and minima) of  $y$  without plotting. We have simply to set  $dy/dx=0$ , solve for  $x$ , and substitute in the  $y$  equation. To determine whether each result is a maximum or minimum, we simply test the sign of  $dy/dx$  for values of  $x$  just before and after each.

Ex. I.  $y = x^4 - 4x^3 + 5.$

Differentiating and factoring the derivative gives

$$\frac{dy}{dx} = 4x^2(x-3).$$

Hence  $dy/dx=0$  where  $x=0, 3$ ; and nowhere else.

Testing the slope  $dy/dx$  on both sides of  $x=0$ :

$$\text{at } x = -1, \quad dy/dx = 4(-1)^2(-4) = -,$$

$$\text{at } x = +1, \quad dy/dx = 4(1)^2(-2) = -.$$

$y$  is decreasing both before and after  $x=0$ . *No extreme here.*

Testing  $dy/dx$  near  $x=3$  (signs only are important):

$$\text{at } x = 2, \quad dy/dx = (+)^2(-) = -,$$

$$\text{at } x = 4, \quad dy/dx = (+)^2(+) = +.$$

$y$  is decreasing before  $x=3$ ; then increasing. Hence it has a *minimum* value at  $x=3$ , viz.

$$y = (3)^4 - 4(3)^3 + 5 = -22.$$

Since  $x=0$  and  $x=3$  are the only values making  $dy/dx=0$ ,  $y$  can have no maximum. The graph should, however, show a horizontal tangent at  $x=0$ . (Fig. 34.)

*Remarks.* (I) The value of  $y$  at  $C$  is not a maximum, but merely the largest reached so far. Inspection of  $dy/dx$  shows the curve to be continually rising to the right of  $x=3$ .

(II) The factored form of  $dy/dx$  is the most convenient: both in seeing that we have found all the points where  $dy/dx=0$ , and in seeing the *sign* of  $dy/dx$  in the tests, without stopping to calculate the *value*.

(III) Merely comparing the values of  $y$  at  $x=0$  and  $x=3$ , viz. 5 and  $-22$ , might erroneously suggest that 5 is a maximum, and  $-22$  a minimum; and would not show the true course of the curve at all.

(IV) Whether to substitute values of  $x$  in the  $y$ -equation or in  $dy/dx$  depends simply on *what information we are after*: one tells the *height* of the graph and the other the *slope*.

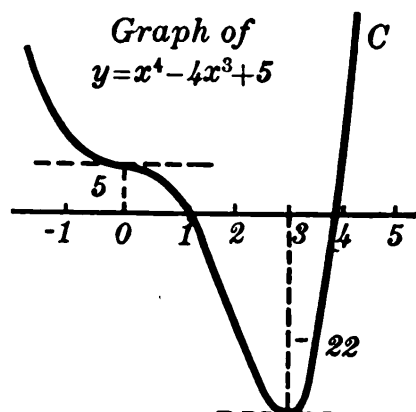

FIG. 34.

## EXERCISES

1. Test each of the following functions for maximum and minimum values. From this information draw the general shape of the graph. (Get more points if in doubt.)

(a)  $y = x^2 - 6x + 5,$

(b)  $y = x^2 + 2x,$

(c)  $y = x^3 - 12x + 1,$

(d)  $y = x^3 - 3x^2 + 3x,$

(e)  $y = x^4 - 8x^2 + 10,$

(f)  $y = x^4 - 8x^3 + 100.$

2. For a beam loaded in a certain way the deflection ( $y$  ft.) at any horizontal distance ( $x$  ft.) from one end is  $y = .00001(30x^2 - x^3)$ . Plot a graph showing how  $y$  varies with  $x$  from  $x = -10$  to  $+30$ . [This graph will be the curve of the beam, exaggerated and inverted.] Calculate the maximum  $y$ ; and check.

3. The work done by exploding a mixture of 1 cu. ft. of coal gas with  $x$  cu. ft. of air is  $W = 83x - 3.2x^2$ . Find the maximum value of  $W$ . (Find  $dW/dx$  by the  $\Delta$  process, for review.)

4. In Ex. 3, p. 34, express the volume of a box in terms of  $x$ , the side of the square corners cut out. [Ans., simplified,  $V = 4x^3 - 80x^2 + 400x$ .] Then find the maximum volume.

5. The speed of a point on a fly-wheel  $t$  sec. after starting was  $V = 40t^2 - t^3$ . Was this increasing or decreasing at  $t = 27$ , and how fast? When was  $V$  greatest?

6. A number  $x$  minus its square is to be made a maximum. Find  $x$ . Check your result by calculating the specified difference for some near-by values and plotting roughly.

7. Given a formula for any quantity, how would you find the rate of increase at any instant? The amount of increase in any very small interval? The maximum and minimum values? Whether increasing or decreasing at any point?

**§ 66. Applied Maxima and Minima.** Practical problems concerning maximum and minimum values are usually stated verbally rather than in terms of formulas or functions. In such cases we must first set up a formula for the quantity in question, expressing it *in terms of some one variable*, say  $x$ . Then we can differentiate and proceed as formerly. (§ 65.)

Ex. I. If a rectangle is to have a perimeter of 40 in., what is its greatest possible area?

(Perhaps you could prove geometrically that the rectangle should be a square? But let us try out our new method.)

The area of *any* rectangle is

$$A = bh. \quad (7)$$

And if the perimeter is to be 40 in., that is,

$$2b + 2h = 40,$$

then  $b = 20 - h$ . Substituting this in (7) gives

$$A = (20 - h)h = 20h - h^2. \quad (8)$$

$A$  is now expressed in terms of a single variable,  $h$ , and we are to find what value of  $h$  will make  $A$  greatest. Differentiating:

$$\frac{dA}{dh} = 20 - 2h.$$

Equating this derivative to zero gives  $h = 10$ . Testing the signs of  $dA/dx$  at  $h = 9$  and  $h = 11$ , shows a maximum at 10; viz.,

$$A = 20(10) - (10)^2 = 100.$$

*Remarks.* (I)  $h=10$  requires also  $b=10$ : a square.

(II) To keep the perimeter constant,  $b$  must change with  $h$  in a definite way. Thus  $A$ , though expressed in (7) in terms of two variables  $b$  and  $h$ , is really a function of either alone; and is not ready for differentiation until so expressed, as in (8).

Ex. II. Find the volume of the largest right circular cone which can be inscribed in a sphere of diameter 10 in.

For any cone, inscribed or not:

$$V = \frac{1}{3} \pi r^2 h. \quad (9)$$

But in the present case we have, from the right triangle in Fig. 35:

$$r^2 + (h-5)^2 = 5^2,$$

whence  $r^2 = 10h - h^2$ .

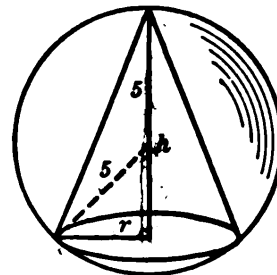

FIG. 35.

Substituting this value for  $r^2$  in (9) above gives

$$V = \frac{1}{3} \pi (10h - h^2)h = \frac{\pi}{3} (10h^2 - h^3). \quad (10)$$

$$\therefore \frac{dV}{dh} = \frac{\pi}{3} (20h - 3h^2),$$

$$\frac{dV}{dh} = 0 \text{ when } h = 0 \text{ or } \frac{20}{3}.$$

A test shows that  $h = 20/3$  makes  $V$  a maximum; viz.,

$$V = \frac{\pi}{3} \left[ 10 \left( \frac{20}{3} \right)^2 - \left( \frac{20}{3} \right)^3 \right] = \frac{4000\pi}{81} = 155.1+.$$

*N.B.* Similarly in any other problem, we first draw a figure (if needed) and write some formula for the quantity which is to be maximized or minimized. Then by using the hypothesis or requirements of the problem, we express everything *in terms of one variable alone*. When in doubt, it is well to ask: What is to prevent our making all the quantities as large or small as we please. This will direct attention to the limitation or specified relation among the several quantities.

### EXERCISES

1. Find as in Ex. I above the largest possible area for a rectangle of perimeter 80 in.

2. Similarly show that a rectangle with any specified perimeter  $P$  will have the largest area when it is square.

3. Find two numbers whose sum shall be 15 and whose product  $P$  shall be as large as possible. Check your answer by calculating  $P$  for some near-by values and plotting roughly.

4. The sum of a number and its square is to be a minimum. Find it. Check by forming the sum for some near-by values.

5. In Ex. 2, p. 33, express the area in terms of  $x$ , and find its maximum value.

6. In Ex. 7, p. 34, express  $L$  as a function of  $x$ . [Ans.,  $L = 4000x - 10x^2$ .] Find what  $x$  and  $y$  will give the strongest beam.

7. What are the dimensions and volume of the largest rectangular box "with square ends" which can go by parcel post? (See Ex. 9, p. 34.) The specification with square ends is superfluous. Why?

8. In Ex. 5, p. 34, express the distance between the ships  $t$  hr. after noon. [Ans.,  $y = \sqrt{400t^2 - 2560t + 6400}$ .] Find the minimum value of  $y^2$ ; and how large  $y$  was then.

9. In Ex. 15, p. 57, the tabulated values of  $Q$  and  $E$  satisfy these equations:  $Q = 2(110 - P)^2$ ,  $E = 30(110 - P)$ . Express the net profit at any price. [Ans., in dollars,  $N = .02P^3 - 4.4P^2 + 272P - 3300$ .] Find what  $P$  gives the maximum  $N$ .

10. In Ex. 4, p. 34, express the combined length of the three new sides in terms of  $x$ . [Ans.,  $L = x + 240/x$ .] Find the minimum value of  $L$ , getting  $dL/dx$  by the  $\Delta$  process.

11. The total area of a rectangular box is to be 600 sq. in. Prove that the volume will be greatest if the box is cubical.

12. A Norman window has vertical sides and a horizontal base, but the top is a semicircle. If the perimeter is 30 ft., what dimensions will give the largest possible area?

13. In locating a maximum or minimum value, why do we set the derivative equal to zero?

**§ 67. Negative and Fractional Exponents.** To simplify many differentiations, and other calculations which follow, we must know the meaning of negative and fractional powers, — such as  $x^{-5}$ ,  $x^{\frac{1}{2}}$ , etc.

A positive integral power denotes simply the product of several equal factors. Thus,  $x^5$  stands for the product of

five  $x$ 's. But obviously  $x^{-5}$  can have no such meaning. Likewise  $x^{\frac{2}{3}}$  and  $x^0$  are quite absurd from this standpoint.

The meanings assigned to such powers may already be familiar to you from algebra. If not, master them thoroughly now.

*Definitions**Illustrations*

- |   |  |
|---|--|
| (1) $x^{-p}$ shall stand for $\frac{1}{x^p}$ ;  | $10^{-3} = \frac{1}{10^3} = .001.$           |
| (2) $x^{p/q}$ shall stand for $\sqrt[q]{x^p}$ ; | $10^{\frac{2}{3}} = \sqrt[3]{10^2} = 4.642.$ |
| (3) $x^0$ shall equal 1, always.                | $10^0 = 1; (-3)^0 = 1, \text{ etc.}$         |

*Remarks.* (I) These definitions are the only ones possible if the usual laws of exponents are to apply in all cases.

For instance, dividing  $x^3$  by  $x^5$  gives  $x^{-2}$  by subtracting exponents; but gives  $1/x^2$  by canceling. Thus  $x^{-2}$  must equal  $1/x^2$ , if the law of subtracting exponents is to be valid here. Similarly  $x^0$  would result from dividing  $x^3$  by  $x^3$ , and hence must equal 1.

Again, if the law of dividing exponents when extracting a root is always to apply:  $\sqrt[q]{x^p} = x^{\frac{p}{q}}$ , etc.

(II) These definitions suffice to determine the value of any numerical expression consisting of rational powers. For instance,

$$y = 7(32)^{-\frac{1}{5}} + 8^0 + \frac{1}{4^{-1} - 5^{-1}}$$

is the same thing as

$$y = \frac{7}{\sqrt[5]{32^3}} + 1 + \frac{1}{\frac{1}{4} - \frac{1}{5}} = 21\frac{7}{8}.$$

Observe here that the negative exponent  $-1$  was applied to 4 and 5 separately, not to the denominator as a whole, — also that we may first extract the fifth root of 32 and then cube the result.

## EXERCISES

1. (a) Why do we take  $x^{-4}$  as standing for  $1/x^4$ , and  $x^0$  as denoting 1? Illustrate by divisions, using definite powers. (b) Similarly, explain why we take  $x^{\frac{1}{2}}$  to mean  $\sqrt{x}$ .

404545A

2. When  $x=10$ , what is the value of  $x^{-2}$ ? Of  $-x^2$ ? (Notice the big difference in the meaning of the  $-$  signs. Also contrast  $x^{\frac{1}{3}}$  with  $1/x^3$ ).

3. What is the meaning of:  $x^{\frac{2}{3}}$ ,  $a^{\frac{1}{2}}$ ,  $x^{\frac{1}{4}}$ ,  $x^{-\frac{1}{2}}$ ,  $x^{-\frac{2}{3}}$ ?

4. Find the values of these expressions:

- (a)  $2^{-1} - 5^{-1}$                       (b)  $8^0 + 3^{-2}$ ,                      (c)  $75 \times 10^{-4}$ ,  
 (d)  $30 \times 2^0$ ,                              (e)  $20^0 \div (2^{-1} - 3^{-1})$ ,              (f)  $(\frac{1}{2})^{-2} \times 10^{-3}$ .  
 (g)  $36^{\frac{2}{3}}$ ,                                      (h)  $27^{-\frac{2}{3}}$ ,                                      (i)  $\frac{1}{4}(16)^{-\frac{1}{4}}$ .

5. Express in a form free from negative and zero exponents, and find the value of each quantity when  $x=2$ :

- (a)  $6x^{-3} + x^{-2} + .5x^0$ ,                      (b)  $\frac{7x - 5x^0}{x^{-4}} + 3x^{-1}$ .

6. Why is  $3x^{-1}$  not the same as  $\frac{1}{3x}$ ?

7. Solve for  $x$ :  $4x - 500x^{-2} = 0$ .

8. If  $y$  varies inversely as  $x^3$ , and  $y=5$  when  $x=2$ , write a formula for  $y$  in terms of  $x$ . May this be regarded as a special case of the *Power Law* (4), p. 82, for some values of  $k$  and  $n$ ? Explain.

9. Express these equations in the form of the *Power Law*:

$$y = \frac{20}{x^4}, \quad z = \frac{150}{7x^6}, \quad r = \frac{\sqrt{v^3}}{5}.$$

[10.] Differentiate  $y = 1/x^2$  by the  $\Delta$ -process. Also differentiate by rewriting  $y$  as  $y = x^{-2}$  and using the formula for  $y = x^n$ . Show that the latter method gives a correct result on simplifying.

**§ 68. Differentiating Negative Powers.** Let us now see about a rule for differentiating any negative power at sight. Can the standard formula for any positive power  $y = x^n$  be used here?

This formula, applied for instance to  $y = x^{-10}$ , would give

$$\frac{dy}{dx} = -10x^{-11};$$

since going down one unit from the exponent  $-10$  would bring us to  $-11$ .\*

\* The easiest way to be clear about negative numbers is to think of their analogy to temperatures below zero.



The correctness of this result can be tested by the original increment method of differentiating. (§ 53.)

Since  $y = x^{-10} = 1/x^{10}$ , we have here  $y + \Delta y = 1/(x + \Delta x)^{10}$ ,

$$\begin{aligned} \text{whence } \Delta y &= \frac{1}{(x + \Delta x)^{10}} - \frac{1}{x^{10}} = \frac{x^{10} - (x + \Delta x)^{10}}{(x + \Delta x)^{10} x^{10}}. \\ \therefore \frac{\Delta y}{\Delta x} &= -\frac{1}{(x + \Delta x)^{10} x^{10}} \cdot \frac{(x + \Delta x)^{10} - x^{10}}{\Delta x}. \end{aligned} \quad (11)$$

The limit of the first fraction on the right as  $\Delta x \rightarrow 0$  is simply  $1/x^{20}$ . The limit of the other fraction is precisely the thing we should have to find if we were differentiating  $x^{10}$ , and hence equals  $10x^9$ . Hence the limit of  $\Delta y/\Delta x$  in (11) is

$$\frac{dy}{dx} = -\frac{1}{x^{20}}(10x^9) = -10x^{-11}.$$

This is the same result as was obtained above from the formula for  $y = x^n$ . Hence that formula works correctly in the case of  $y = x^{-10}$ .

By precisely the same steps it can be shown to work in the case of any negative power  $y = x^{-n}$ . (Ex. 20 below.) Hence we can differentiate many fractions without further recourse to the increment method, — by simply regarding the fractions as negative powers.

*E.g.*, suppose that  $y = 4/x^{100}$ .

This is 4 times  $1/x^{100}$ , or  $4x^{-100}$ .

$$\therefore \frac{dy}{dx} = -400x^{-101}, = -\frac{400}{x^{101}} \left[ \text{not } -\frac{1}{400x^{101}} \right].$$

Notice how complicated this differentiation would be by the  $\Delta$ -process.

Negative powers often arise in problems on maxima and minima.

**Ex. I.** An open rectangular tank is to contain 500 cu. ft. What is the least possible cost, if the base costs \$3 per sq. ft. and the sides \$2 per sq. ft.?

The base must be a square. (Cf. Ex. 7, p. 98.)

The four sides contain  $4hx$  sq. ft. and cost  $8hx$  dollars. The base costs  $3x^2$  dollars. Hence the total cost is

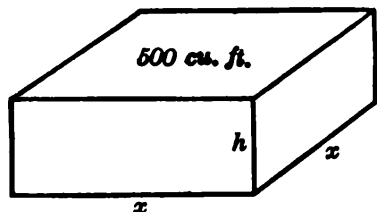

FIG. 36.

$$T = 3x^2 + 8hx.$$

But as the volume is to be 500 cu. ft.,  $x^2h = 500$ , or

$$h = \frac{500}{x^2}. \quad (12)$$

$$\therefore T = 3x^2 + 8\left(\frac{500}{x^2}\right)x = 3x^2 + 4000x^{-1}.$$

$T$  is now expressed in terms of  $x$  alone. To minimize it:

$$\frac{dT}{dx} = 6x - \frac{4000}{x^2} = 0.$$

$$\therefore x = \sqrt[3]{2000/3} = 8.74, \text{ approx.,}$$

giving  $h = 6.55$ , and  $T = 687.5$ , approx.

*Remark.* To find the relative values of  $h$  and  $x$  in this tank, we may best proceed thus:

$$h = \frac{500}{x^2} = \frac{500x}{x^3} = \frac{500x}{2000/3}.$$

Simplified, this gives  $h = \frac{3}{4}x$ ; and  $T = 9x^2$ .

### EXERCISES

1. Differentiate, and write the results in tabular form:

$$(a) \quad x^{-4}, \quad 7x^{-2}, \quad -\frac{1}{3}x^{-12}, \quad \frac{15}{x^3}, \quad \frac{-9}{2x^{40}}, \quad \frac{k}{x^5}, \quad \frac{c}{5x^{10}}$$

$$(b) \quad x^6 + \frac{1000}{x^4}, \quad \pi x^2 - \frac{80}{x}, \quad \frac{4}{3x^6} - 91x, \quad \frac{k}{x} + \frac{c}{x^2}.$$

2. For a certain weight of a gas the volume varied thus with the pressure:  $V = 300/P$ . Find the rate of increase of  $V$  at  $P = 10$ . About how much did  $V$  change while  $P$  increased from 10 to 10.137?

3. Gravitational acceleration ( $g$  ft./sec.<sup>2</sup>) varies thus with the distance ( $r$  miles) from the center of the earth:  $g = 512000000/r^2$ . Find the rate of change per mile at  $r = 4000$ .

4. The intensity of light varies inversely as the square of the distance from the source. If  $I = 120$  when  $D = 10$ , write a formula for

$I$  at any distance  $D$ . Also find the rate of change per unit distance at  $D=20$ .

5. The electrical resistance of a wire varies inversely as the square of the diameter  $x$ . If  $R=20$  when  $x=2$ , find the formula for  $R$ . Also find the rate of change of  $R$  at  $x=5$ .

6. The current in an electric circuit varies inversely as the resistance. If  $c=50$  when  $R=5$ , find the rate of change of  $c$  per unit change in  $R$  at  $R=10$ .

7. In Ex. 10, p. 34, express the total cost as a function of one dimension alone, and find the minimum cost.

8. Find the most economical dimensions of an open rectangular box which is to contain 400 cu. ft., if the base costs 50¢ per sq. ft. and the sides 30¢ per sq. ft.

9. The same as Ex. 8, if the base and sides both cost \$2 per sq. ft.

10. An open cylindrical cup is to contain  $125\pi$  cu. in. What dimensions will require the least material?

11. The same as Ex. 10, for a closed cylindrical can, to contain  $250\pi$  cu. in.

12. The same as Ex. 11, if the can is to have its top and bottom of double thickness.

13. What number, added to twenty times its reciprocal, gives the smallest sum? Check your result by calculating the sum for a few near-by values and plotting roughly.

14. Find by using the derivative the smallest possible perimeter for a rectangle whose area is to be 100 sq. in.

15. In Ex. 8, p. 34, express the area of the page as a function of the length of the print lines. [*Ans.*,  $A = 3L + 66 + 120/L$ .] Find the exact minimum of  $A$ .

16. Like Ex. 15, changing the area of the print column to 30 sq. in. and the bottom margin to 2 in.

17. Like Ex. 10 above but containing 1 gallon (231 cu. in.).

18. A rectangular box with a square base is to contain 200 cu. in. and have a cover cap which will slide on tight for 3 inches. Express the total surface of the box and cap, — virtually two open boxes, — and find its minimum value. [The resulting equation will need to be solved by trial. § 21.]

19. Similar to Ex. 18 but with a volume of 800 cu. in., and a cap which slides on to one fourth the way down.

20. Prove the differentiation formula (5) correct for any negative integral power,  $y = x^{-n}$ . [The steps are the same as for  $x^{-10}$  above.]

**§ 69. Further Notation.** The derivative of any function  $f(x)$ , being itself some function of  $x$ , is often denoted by  $f'(x)$ , read “ $f$  prime of  $x$ .” Thus:

$$\text{if } f(x) = x^4, \quad \text{then } f'(x) = 4x^3.$$

A derivative is often denoted also by writing  $\frac{d}{dx}$ , or  $\frac{d}{dr}$ , etc., before the function differentiated. *E.g.*,

$$\frac{d}{dx}(x^4) = 4x^3, \quad \frac{d}{dr}(\pi r^2) = 2\pi r.$$

Thus, if  $y = f(x)$ , the following notations are equivalent:

$$\frac{dy}{dx} = \frac{d}{dx}(y) = \frac{d}{dx}f(x) = f'(x) = \mathbf{L}_{\Delta x \rightarrow 0} \left( \frac{\Delta y}{\Delta x} \right).$$

**§ 70. Repeated Differentiations.** Suppose we have given a formula for the distance ( $y$  ft.) traveled by an object in  $t$  min., say

$$\text{dist.}, y = 20t^3 - t^4. \quad (13)$$

And suppose we wish to find the *acceleration* at any time, — *i.e.*, the rate at which the speed is changing.

Differentiating (13) gives the speed at any time:

$$\text{speed}, v = 60t^2 - 4t^3.$$

But we wish to know how fast the speed is changing. Hence we must differentiate the speed. (The fact that we have already performed a differentiation in getting the speed makes no difference.)

$$\therefore \text{ accel.} = \frac{dv}{dt} = 120t - 12t^2.$$

For instance, at  $t = 5$ , the acceleration is  $120(5) - 12(5)^2$  or 300 units. That is, the speed is increasing at the rate of 300 ft./min. gained per min. This is abbreviated 300 ft./min.<sup>2</sup>

To make this calculation, we had to differentiate twice in succession. If we had wished to know the rate at which the

acceleration is increasing, we should have had to differentiate a third time.

In general, *to find the rate at which any quantity is changing, we must find the derivative of that quantity*, — no matter how many differentiations may already have been performed in getting that quantity.

There are many problems requiring repeated differentiations. Another illustration follows.

Ex. I. A steel beam loaded in a certain way bends as in Fig. 37, the deflection or ordinate at any distance ( $x$  ft.) from one end being

$$y = .00006 (x^3 - 15x^2).$$

Find how fast the slope is changing per horizontal unit at  $x = 10$ .

*Solution.* Differentiating once gives the slope:

$$\text{slope, } l = .00006 (3x^2 - 30x). \quad (14)$$

Differentiating again gives the rate at which the slope is changing:

$$\text{rate, } \frac{dl}{dx} = .00006 (6x - 30), \quad = .0018 \text{ at } x = 10.$$

That is, the slope is increasing at the rate of .0018 per horizontal foot. To check this, let us calculate the slopes at  $x = 9$  and  $x = 11$ . By (14) these are  $l = -.00162$  and  $l = +.00198$ . The increase is  $\Delta l = .00360$  in two horizontal units, making the rate .0018 per unit.

*Definition.* The rate at which the slope of a curve is changing at any point is called the *flexion*.

**§ 71. Derivatives of Any Order.** The derivative of the derivative  $dy/dx$  is called the “second derivative” of the original function  $y = f(x)$ , and is denoted \* by  $\frac{d^2y}{dx^2}$  or  $f''(x)$ .

Similarly the derivative of  $f''(x)$  is called the “third derivative,” and is denoted by  $f'''(x)$  or  $\frac{d^3y}{dx^3}$ . And so on.

\* Observe where the indices 2 are written. We may think of these as indicating that the operation denoted by  $\frac{d}{dx}$  is to be performed twice upon  $y$ .

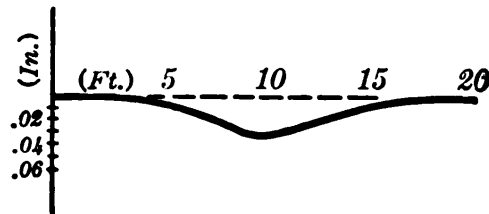

FIG. 37.

Ex. I. If  $y = x^{10} + 1/x^2$ , find  $d^2y/dx^2$ .

$$\frac{dy}{dx} = 10x^9 - 2x^{-3}$$

$$\frac{d^2y}{dx^2} = 90x^8 + 6x^{-4}$$

$$\frac{d^3y}{dx^3} = 720x^7 - 24x^{-5}$$

### EXERCISES

1. Find the second derivatives of the following:

$$y = x^8 + 2x^3 + 3x,$$

$$y = 5/x^{10},$$

$$y = 40t^2 - t^5,$$

$$P = x + 3 + \frac{160}{x^2},$$

$$V = \frac{4}{3}\pi r^3,$$

$$S = t(36 - t^2).$$

2. Find the fourth derivative of  $y = x^5 + 6x^3 - 17x + 2$ .

3. Find  $d^7y/dx^7$  if  $y = .02x^{10} + x^4/3 + 1/x$ .

4. For a ball thrown straight upward the height after  $t$  sec. was  $y = 80t - 16t^2$ . Find the speed and acceleration at any instant. What values at  $t = 1$ ?

5. The same as Ex. 4 for the rolling ball in Ex. 4, p. 62.

6. In the curve  $y = x^3$  find the slope and flexion at  $x = 2$ .

7. The same as Ex. 6 for the suspension cable in Ex. 7, p. 45.

8. The same as Ex. 6 for the actual curve of the beam in Ex. 2, p. 95.

9. How fast is the slope of the curve  $y = x^3 - 2x + 1$  changing (per horizontal unit) at  $x = 2$ ? Check by finding the exact slopes at  $x = 1.99$  and  $2.01$ .

10. In  $t$  seconds after brakes were applied a train moved a distance ( $s$  ft.) given by  $s = 44t - 4t^2$ . Find how fast it was moving when  $t = 3$ . Also how fast its speed was then decreasing.

11. The distance traveled by an object in  $t$  minutes was  $y = 4t^3 - .1t^4$ . Plot a graph showing  $y$  as a function of  $t$  from  $t = 0$  to 30, substituting 0, 5, 10, etc.

[12.] Plot a graph showing how the speed  $v$  increased with  $t$  in Ex. 11. What were the maximum and minimum values of  $v$ , — by the graph, and by calculation?

13. How would you proceed to find the rate at which the acceleration of a moving object is increasing at any instant: (a) If given a formula for the speed at any time? (b) If given a formula for the distance traveled?

§ 72. **Derived Curves.** The slope of any given curve  $f$  varies with  $x$  in some definite way. This variation is most clearly shown by plotting another curve  $f'$ , whose height is everywhere equal to the slope of curve  $f$ . (Fig. 38.)

Observe how the zero slope of  $f$  at  $A$ ,  $C$  and  $E$  shows in the "derived curve"  $f'$ ; also the maximum and minimum slopes of  $f$  at  $B$  and  $D$ .\*

Further derived curves can be drawn to show the variation of  $f''(x)$ ,  $f'''(x)$ , etc., — and this is often done in studying motion or the bending of loaded beams. We may, then, interpret  $f''(x)$  either as the flexion of curve  $f$ , or as the slope of  $f'$ , or as the height of the second derived curve  $f''$ .

§ 73. **Points of Inflection.** In drawing an accurate graph it is helpful to locate the "points of inflection" (such as  $B$  and  $D$ , in Fig. 38), where the curve has a maximum or minimum slope. For near such points the curve is very nearly straight, almost coinciding with its tangent line for some distance.

Ex. I. Find the maximum and minimum slopes of curve  $f$  in Fig. 38, if the height at any point is

$$y = x^4 - 8x^2 - x + 16. \quad (15)$$

The slope at any point is

$$l = \frac{dy}{dx} = 4x^3 - 16x - 1. \quad (16)$$

\* Slope is not simply a measure of steepness. It has a *sign*, and at  $D$  the slope of  $f$  has fallen to a negative value lower than that on either side for some distance.

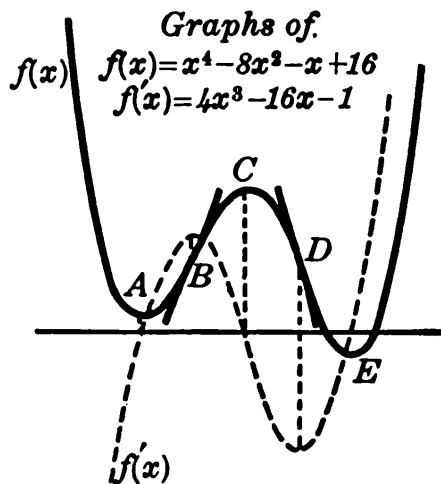

FIG. 38.

To make this slope a maximum or minimum, we make *its* derivative zero :

$$\frac{dl}{dx} = 12x^2 - 16 = 0. \quad (17)$$

This gives  $x = \pm \sqrt{4/3} = \pm 1.155$ , approx.

Testing  $x = -2, -1, 1, 2$ , in (17) shows  $l$  to be a maximum at  $x = -1.155$ , and a minimum at  $x = 1.155$ . By (16) these maximum and minimum slopes are 11.32 and  $-13.32$ ; and by (15) they occur at points  $B$  and  $D$ , having  $y = 8.19$  and  $5.96$ .

Observe that the derivative to be tested "before and after" is the one which we set equal to zero.

**§ 74. Maximum Rates.** It is often important to know when a quantity will be increasing most rapidly. This is very different from the question as to when the quantity will be greatest.

For instance, in Fig. 38, the slope of curve  $f$  is greatest at  $B$ , but is changing very slowly in that vicinity. Again, in the same curve, the height is increasing most rapidly at  $B$ , but is greatest at  $C$ . Another illustration follows.

Ex. I. The distance ( $y$  ft.) traveled by an object in  $t$  min. was

$$y = 6t^5 - t^6.$$

Find when the acceleration was increasing most rapidly.

The question is not when the acceleration was greatest but when *its rate of increase* was greatest.

$$v = \frac{dy}{dt} = 30t^4 - 6t^5, \quad = \text{speed},$$

$$a = \frac{d^2y}{dt^2} = 120t^3 - 30t^4, \quad = \text{accel.}$$

The rate of increase of the acceleration is

$$R = \frac{d^3y}{dt^3} = 360t^2 - 120t^3, \quad \text{to be max.} \quad (18)$$

$$\therefore \frac{dR}{dt} = 720t - 360t^2 = 0.$$



This gives  $t=0$  or  $2$ . The latter value makes  $R$  a maximum,

for at  $t=1$  and  $3$ :  $\frac{dR}{dt} = +, -$ .

To find the maximum  $R$ , substitute  $t=2$  in (18).

*Remark.* It is helpful to label successive derivatives and introduce a single letter (as  $R$  above) for the quantity which is to be a maximum or minimum. Decide at the outset which quantity that is, and when you reach it in differentiating set *its* derivative equal to zero.

### EXERCISES

1. The distance traveled by an object in  $t$  min. was  $y=60t^4-t^5$ . Find when the speed was a maximum; likewise the acceleration.

2. In Ex. 1 find when the acceleration was increasing most rapidly. Check roughly by calculating the acceleration at several instants before and after, and noting about how it increased.

3. Find where the slope of the curve  $y=18x^2-x^4$  is a maximum. Also where the slope is increasing most rapidly.

4. The height of a curve is  $y=30x^4-x^5$ . Find where the slope is a maximum, and where the flexion increases most rapidly.

5. The kinetic energy of a train  $t$  minutes after starting was  $E=500t^4+15t^5-t^6$ . Find when  $E$  was increasing most rapidly and how rapidly then.

6. A beam loaded in a certain way bends so as to form the curve  $y=.00002x^4-.003x^2$ . Plot from  $x=0$  to  $x=10$ . Show the exact tangent at any point of inflection.

7. (A) Plot the curve  $y=x^3-15x$ , locating the maximum and minimum  $y$ , and the point of inflection. What slope at the latter? (B) Plot also the first and second derived curves.

[8.] Find  $dy/dx$  from  $y=(x^7+1)^2$  after multiplying out. [*Ans.*,  $14x^6(x^7+1)$ .] Can you see any simple rule which would give this same result without multiplying out?

**§ 75. Indirect Dependence.** Heretofore each function that we have differentiated has been expressed directly in terms of its independent variable, — say  $y$  in terms of  $x$ . But there are cases in which  $y$  is given in terms of some other quantity  $u$ , and  $u$  in terms of  $x$ .  $y$  is then in reality a function of  $x$ , although expressed as such only indirectly.

For instance, if  $y = u^5$  and  $u = x^2$ , then  $y = x^{10}$ .

In this instance, it is easy to change from the indirect relation between  $y$  and  $x$  in terms of  $u$ , to the direct relation  $y = x^{10}$ . And if we wish to know the rate of increase of  $y$  per unit change in  $x$ , we simply differentiate this last equation, getting  $dy/dx = 10x^9$ .

But it is sometimes very inconvenient to change to the direct relation between  $y$  and  $x$ ; and we therefore need some method of finding  $dy/dx$  even while  $y$  is expressed indirectly in terms of  $u$ .

Notice the difference between  $dy/dx$  and  $dy/du$ . The latter would be the rate of increase of  $y$  per unit change in  $u$ . We want  $dy/dx$ .

(To distinguish verbally between  $dy/dx$  and  $dy/du$ , we call one the derivative with respect to  $x$ , and the other the derivative with respect to  $u$ .)

**§ 76. Differentiating a Function of a Function.** If  $y$  is given as a function of  $u$ , and  $u$  as a function of  $x$ , say

$$y = F(u), \quad u = f(x), \quad (19)$$

how can we find  $dy/dx$  immediately?

Increasing  $x$  by  $\Delta x$  would evidently increase  $u$  by some  $\Delta u$ , and hence  $y$  by some  $\Delta y$ . We seek  $dy/dx$ , the limit of  $\Delta y/\Delta x$ . But evidently

$$\frac{\Delta y}{\Delta x} = \frac{\Delta y}{\Delta u} \cdot \frac{\Delta u}{\Delta x}. \quad (20)$$

Taking the limits of these fractions (if the limits exist) gives

$$\frac{dy}{dx} = \frac{dy}{du} \cdot \frac{du}{dx}. \quad (21)$$

That is, to find  $dy/dx$  in (19) above, we have merely to find  $dy/du$  from the first equation, and  $du/dx$  from the second, and then multiply the results.

Thus if  $y$  is increasing at the rate of 10 units per unit change in  $u$ , and  $u$  at the rate of 6 units per unit of  $x$ , then  $y$  is increasing at the rate of 60 units per unit of  $x$ .

Ex. I. If  $y = u^7 + 2u^4 - 3$ , and  $u = x^5 + 1$ , find  $dy/dx$ .

Here  $\frac{dy}{du} = 7u^6 + 8u^3$ ,  $\frac{du}{dx} = 5x^4$ .

Hence by (21),  $\frac{dy}{dx} = (7u^6 + 8u^3)(5x^4)$ .

It would be possible here to express  $y$  directly in terms of  $x$ , multiply out, and then differentiate. But this would be inconvenient.

Formula (21) will be used in deriving further differentiation formulas; and should be carefully memorized.

§ 77. **Differentiating a Power of a Quantity.** Let  $u$  denote any function of  $x$ , or quantity involving  $x$ . Then if

$$y = u^n,$$

$dy/du = nu^{n-1}$ , and hence by (21) above:

$$\frac{dy}{dx} = nu^{n-1} \frac{du}{dx}, \quad (22)$$

That is, *the derivative of any integral power of a quantity equals the given exponent times the next lower power of that same quantity, times the derivative of that quantity.*

By this theorem we can now differentiate at sight any integral power of a quantity, without first multiplying out or using the  $\Delta$ -process.

Ex. I.  $y = (x^2 + 3x - 7)^{100}$ .

Here  $\frac{dy}{dx} = 100(x^2 + 3x - 7)^{99} \cdot (2x + 3)$ .

For any numerical value of  $x$ , this result can be calculated very quickly by logarithms. (Chap. VI.)

*N.B.* Here  $y$  is given directly in terms of  $x$ , but not as a *power* of  $x$ . To differentiate by the short power-rule, we must regard  $y$  as a power of a *quantity*  $u$  ( $=x^2 + 3x - 7$ ); and thus from the practical standpoint the case is one of indirect dependence, coming under (22) or (21) above.

Ex. II.  $y = \frac{4}{(10-x)^3}$  *i.e.*,  $y = 4(10-x)^{-3}$ .

Here  $\frac{dy}{dx} = -12(10-x)^{-4}(-1) = \frac{12}{(10-x)^4}$ .

(The factor  $-1$  comes in as the derivative of the quantity in parentheses.)

Without formula (22) we should have had to resort to the  $\Delta$  process.

### EXERCISES

1. In the following cases of indirect dependence find  $dy/dx$ :

(a)  $y = u^3 - 6u + 4$ ,  $u = x^2 - 1$ ; (b)  $y = u^5 + 5/u$ ,  $u = x^3 + 10$ ;

(c)  $y = u^{50} - .002u^{10}$ ,  $u = 7x + 3$ ; (d)  $y = u^{20} - 75$ ,  $u = x^4$ .

2. In Ex. 1 (d) express  $y$  in terms of  $x$ , differentiate, and compare.

3. In the following find the derivative with respect to  $t$ :

(a)  $V = x^3$ ,  $x = 3t^4 - 17$ ; (b)  $A = \pi r^2$ ,  $r = .25t^2 + t$ .

[4.] The edge of a cube ( $x$  in.) increased at the rate of .02 in./hr. Can you find how fast the volume was increasing at the instant when  $x = 20$ ? (Hint: We know  $dx/dt$  and wish to find  $dV/dt$ .)

5. Write at sight the derivatives of the following:

(a)  $y = (x^4 + 25)^{100}$ , (b)  $y = (16 - t^2)^7$ ,

(c)  $z = 5(2x + 7)^9$ , (d)  $V = \frac{4}{3}\pi(1-x)^3$ ,

(e)  $y = \frac{20}{(t^3 - 1)^7}$ , (f)  $y = \frac{5}{4(9+x)^2}$  ✓

(g)  $u = \frac{3}{4(8-t)}$ , (h)  $Q = \frac{5}{4(9+x^2)}$ .

6. In Ex. 6, p. 49, find how fast  $n^2$  changes with  $f$ , at  $f = 30$ .

7. In Ex. 16, p. 57, express the total amount of heat as a function of the distance  $x$  from  $A$ . Find the minimum value of  $H$ .

### § 78. Rate Problems Requiring Indirect Differentiation.

EXAMPLE: The edge ( $x$  in.) of an expanding metal cube is increasing at the rate of .04 in./hr. How fast is the volume increasing (per hour) at the instant when  $x = 10$ ?

This is in effect a problem of indirect dependence: We know how  $V$  depends on  $x$ , and how  $x$  varies with the time  $t$ :

$$V = x^3, \quad \text{and} \quad \frac{dx}{dt} = .04;$$

and we are to find how  $V$  varies with  $t$  at a certain instant.  $V$  depends on  $t$ , — but through the medium of  $x$ , so to speak.

By § 76,

$$\frac{dV}{dt} = \frac{dV}{dx} \cdot \frac{dx}{dt}, \quad (23)$$

$$\text{i.e.,} \quad \frac{dV}{dt} = 3x^2 \frac{dx}{dt}. \quad (24)$$

At the specified instant this becomes

$$\frac{dV}{dt} = 3(10)^2(.04) = 12.$$

*I.e.*, the volume is increasing at the rate of 12 cu. in./hr.

Notice particularly the factor  $dx/dt$  in (24). Evidently this arises from the fact that we are differentiating with respect to a different variable ( $t$ ) than that in terms of which  $V$  is expressed (*viz.*  $x$ ).

It is interesting to see how this extra factor enters if we differentiate by the  $\Delta$  process. During any interval  $\Delta t$ ,  $x$  increases by some  $\Delta x$  and  $V$  by some  $\Delta V$ . Then

$$\begin{aligned} V + \Delta V &= (x + \Delta x)^3 = x^3 + 3x^2\Delta x + 3x\Delta x^2 + \Delta x^3. \\ \therefore \Delta V &= 3x^2\Delta x + 3x\Delta x^2 + \Delta x^3. \end{aligned}$$

Since we seek the rate per *hour* we must divide by  $\Delta t$ . This will not cancel a factor, as dividing by  $\Delta x$  would; but we can *factor out* a  $\Delta x$ :

$$\frac{\Delta V}{\Delta t} = (3x^2 + 3x\Delta x + \Delta x^2) \frac{\Delta x}{\Delta t}.$$

Now as  $\Delta t$  approaches zero, so does  $\Delta x$ . Hence the quantity in parentheses approaches  $3x^2$ ; and the average rates  $\Delta x/\Delta t$  and  $\Delta V/\Delta t$  approach the instantaneous rates  $dx/dt$  and  $dV/dt$ , respectively.

$$\therefore \frac{dV}{dt} = 3x^2 \frac{dx}{dt}.$$

This shows the factor  $dx/dt$  in (24) coming in automatically. (Why does it not enter when we differentiate  $V = x^3$  with respect to  $x$ ?)

This work suggests that in any case where we have one quantity ( $y$ ) expressed in terms of another ( $x$ ), and we differentiate with respect to the time, or any other third variable ( $t$ ), the result will be the ordinary derivative ( $dy/dx$ ) multiplied by an extra factor ( $dx/dt$ ):

$$\text{if } y=f(x), \text{ then } \frac{dy}{dt} = f'(x) \cdot \frac{dx}{dt}. \quad (25)$$

This is, in fact, precisely what the general theorem on indirect dependence shows, merely changing  $u$  and  $x$  in (21) to  $x$  and  $t$ .

Hereafter, then, we may differentiate with respect to a third variable  $t$  as just stated without explicitly employing (21).

$$\text{Ex. I. } y = x^6. \quad \text{Here } \frac{dy}{dt} = 6 x^5 \frac{dx}{dt}.$$

$$\text{Ex. II. } S = 4 \pi r^2. \quad \text{Here } \frac{dS}{dt} = 8 \pi r \frac{dr}{dt}.$$

*N.B.* Compare Ex. I carefully with this differentiation:

$$y = (t^{10} + 1)^6, \quad \frac{dy}{dt} = 6 (t^{10} + 1)^5 \cdot 10 t^9.$$

In each case we are differentiating with respect to  $t$  a power of a quantity, not simply  $t$ . In one case the quantity is  $(t^{10} + 1)$ , in the other,  $x$ .

**§ 79. Related Rates.** It is profitable to look at the foregoing problem of the expanding cube from another angle.

There we had given two related quantities  $V$  and  $x$

$$V = x^3,$$

and the rate at which one of them was changing

$$dx/dt = .04,$$

and we had to find how fast the other was changing.

This is typical of many problems which arise in scientific work. In any such case we simply differentiate the given equation of relationship (like  $V = x^3$ ) with respect to  $t$ , and substitute any given values.

**Ex. I.** From a conical filter whose height is three times the radius, a fluid filtered out at the rate of .3 cu. in./min. How fast was the level falling, when the fluid was 6 in. deep in the middle? (Fig. 39.)

For the shrinking fluid cone we have

$$\text{Given} \quad \frac{dV}{dt} = -.3;$$

To find  $\frac{dh}{dt}$  when  $h = 6$ .

Now

$$V = \frac{1}{3} \pi r^2 h.$$

But  $r = \frac{1}{3} h$  continually. (Why?) Substituting this:

$$V = \frac{1}{27} \pi h^3.$$

$$\therefore \frac{dV}{dt} = \frac{1}{9} \pi (3h^2) \frac{dh}{dt}.$$

Substituting given values:

$$-.3 = \frac{1}{9} \pi (6^2) \frac{dh}{dt}.$$

$$\therefore \frac{dh}{dt} = -.024, \text{ approx.}$$

The level was falling at the rate of .024 in./min.

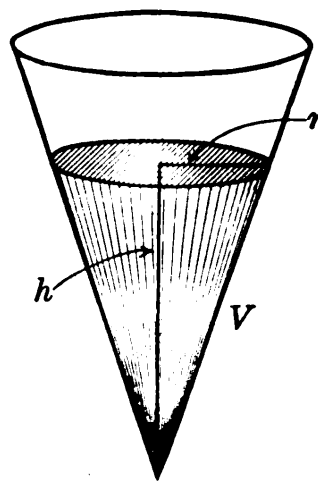

FIG. 39.

### EXERCISES

1. Find the derivative with respect to  $t$  of each of the following quantities (assuming all the letters to vary with  $t$ ):

$$\begin{array}{llll} y = x^8, & y = 5x^{20}, & y = .002/x^4, & y = .7x^2 - 20x, \\ V = x^3, & S = 4\pi r^2, & W = 5.9t^2, & M = v^2 + 5/v, \\ A = x^2, & Q = 100/r^3, & T = 3.8s - s^2, & U = L - 84/L^2. \end{array}$$

2. The radius of a spherical balloon increased at the rate of .02 ft./min. Find how fast the volume was increasing at the instant when  $r = 20$ .

3. In Ex. 2 check your differentiation by the  $\Delta$  process.

4. The volume of a cube was increasing at the rate of 600 cu. in./min. at the instant when the edge was 20 inches. How fast was the edge changing?

5. The height of a cone constantly equals the diameter of the base. If the volume increases at the rate of 20 cu. in./hr., find the rate of change of the radius when  $r = 2$ .

6. Sand, falling at the rate of 2 cu. ft./min., forms a conical pile whose radius always equals twice the height. How fast is the height increasing when  $h=10$ ? [How do you account for the very small answer?]

7. In § 79, Ex. I, take different dimensions and rates; and solve.

8. A cylinder contracts so that its height always equals three times its radius. If the volume is decreasing at the rate of 2 cu. in./hr., how fast is  $r$  decreasing when  $r=10$ ?

9. A sphere is expanding at the rate of 12 cu. in./min. Find how fast the radius and surface area are increasing when  $r=10$ . About how much will they increase in the next 6 sec.?

10. The volume of a quantity of gas varied thus:  $V=600/p$ . If  $p$  increased at the rate of .2 lb./min., how fast was  $V$  changing when  $p=20$ ?

11. The volume ( $V$  cc.) of a kilogram of water varies with the temperature ( $T^\circ$  C.) thus:  $V=1000-.0576 T+.00756 T^2-.0000351 T^3$ . If  $T$  rises at the rate of .02 deg./min., how fast will  $V$  be increasing when  $T=50$ ?

12. The volume of a balloon was increasing with the temperature at the rate of 110 cu. ft./deg., when the radius  $r$  was 20 ft. How fast was  $r$  then increasing, per degree?

### § 80. Differentiating Implicitly.

EXAMPLE: A ship  $A$  sailing eastward at the rate of 12 mi./hr. left a certain point five hours before another ship  $B$  arrived from the north coming at 16 mi./hr. How fast was the distance  $AB$  changing two hours after  $A$  left?

Let Fig. 40 represent the positions at any time. Then

$$\frac{dx}{dt} = 12, \quad \frac{dy}{dt} = -16,$$

and we are to find  $dz/dt$  when  $x=24$  and  $y=48$ .

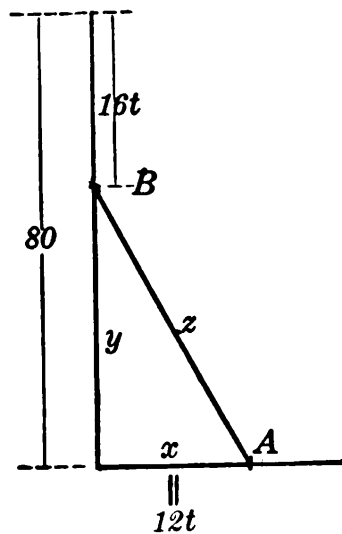

FIG. 40.



At any time,  $t$  hr. after  $A$  left, we should have

$$\begin{aligned}x &= 12t, & y &= 80 - 16t. \\ \therefore z &= \sqrt{x^2 + y^2} = \sqrt{6400 - 2560t + 400t^2}.\end{aligned}\tag{26}$$

We have as yet no formula for differentiating such a function, this being a *fractional* power. But we can proceed as follows.

Since  $z^2$  and  $x^2 + y^2$  are constantly equal, they must be changing at the same rate. Hence their derivatives with respect to  $t$  are equal:

$$\frac{d}{dt}(z^2) = \frac{d}{dt}(x^2 + y^2).$$

But by § 77, differentiating  $z^2$  with respect to  $t$  gives  $2z dz/dt$ ; etc.

$$\therefore 2z \frac{dz}{dt} = 2x \frac{dx}{dt} + 2y \frac{dy}{dt}.\tag{27}$$

Substituting the given values, with the corresponding value of  $z$ ,  $= \sqrt{24^2 + 48^2}$  or  $\sqrt{2880}$ :

$$\begin{aligned}2\sqrt{2880} \frac{dz}{dt} &= 2(24)(12) + 2(48)(-16). \\ \therefore \frac{dz}{dt} &= \frac{-480}{\sqrt{2880}} = -8.95.\end{aligned}$$

That is, the distance  $AB$  was decreasing at the rate of 8.9 mi./hr.

*Remarks.* (I) This method of finding  $dz/dt$  without first solving explicitly for  $z$  is called *implicit differentiation*. Notice carefully the reasoning involved; also that the result would have been badly erroneous if we had overlooked the negative sign for  $dy/dt$ .

(II) When one side of a varying triangle remains fixed, its numerical value should be used from the outset, rather than an unknown letter. One term in the equation corresponding to (27) is then zero.

(III) The minimum value of  $z$  above was found in Ex. 8, p. 98, by first finding the minimum of  $z^2$ . We can now find it directly:

Put  $dz/dt=0$ , and by equation (27) we must have

$$x \frac{dx}{dt} + y \frac{dy}{dt} = 0.$$

That is,  $12x - 16y = 0$ . Or introducing  $t$  by (26) above:

$$12(12t) - 16(80 - 16t) = 0.$$

Solving this for  $t$  gives  $t=3.2$ , whence  $z=48$ , — the minimum.

### EXERCISES

1. In Ex. I above, just how does the equation  $2x \, dx/dt + 2y \, dy/dt = 2z \, dz/dt$  follow from the one preceding? What would the corresponding differentiation give in case we had  $x^2 + 2500 = z^2$  constantly? What if we had  $x^2 + y^2 = 100$  constantly?

2. A ladder 25 ft. long leans against a vertical wall. If its foot is pulled away horizontally at the rate of .3 ft./sec., how fast is the top descending when 20 ft. high?

3. An airplane flying horizontally at the rate of 80 ft./sec. passes straight over a fort, at an elevation of 6000 ft. How fast is its distance from the fort increasing 100 sec. later?

4. A launch is pulled upstream by a cable fastened to a bridge 60 ft. above. If the cable is pulled in at the rate of 6 ft./min., how fast will the boat be advancing when 100 ft. of cable are out?

5. A balloon  $B$  was descending straight over a railroad track at the rate of 60 ft./sec. An engine  $E$  was approaching at the rate of 80 ft./sec.; but was 1800 ft. away from the point directly below  $B$ , when  $B$  was 2600 ft. high. How fast was the distance  $BE$  changing 10 sec. later? When was  $BE$  least, and how small?

6. An auto running constantly 60 ft./sec. passed directly under a balloon just as a bomb was released. If the height of the bomb after  $t$  sec. was  $h=800-16t^2$ , how fast was the distance between the bomb and the auto changing when  $t=5$ ?

7. In Ex. 6 when were the bomb and the auto nearest?

8. The baseball "diamond" is a square 90 ft. on each side. A ball was batted along the third-base line with a speed of 100 ft./sec. How fast was its distance from first base changing .2 sec. after starting?

9. The same as Ex. 8, .5 sec. after starting, if the ball was moving 80 ft./sec.

10. A train running straight east at the constant rate of 40 mi./hr. left a town 4 hours before another arrived from the north, coming at the

rate of 30 mi./hr. Find how fast the distance between the trains was changing two hours after the first started.

11. In Ex. 10 when were the trains nearest? How near?

12. A rectangle is inscribed in a circle of diameter 20 in. If we increase the base at the rate of .4 in./min., how fast will the altitude be decreasing when equal to 12 in.?

**§ 81. Differentiating Fractional Powers.** The formula for differentiating  $u^n$  applies to fractional as well as integral powers.

For instance, if

$$y = u^{\frac{5}{3}},$$

then,

$$\frac{dy}{dx} = \frac{5}{3} u^{\frac{2}{3}} \frac{du}{dx}.$$

For here  $y^3 = u^5$ ; and differentiating this implicitly with respect to  $x$  (§ 80) would give:

$$3 y^2 \frac{dy}{dx} = 5 u^4 \frac{du}{dx}.$$

$$\therefore \frac{dy}{dx} = \frac{5}{3} \frac{u^4}{y^2} \frac{du}{dx}.$$

But by (25),

$$y^2 = (u^{\frac{5}{3}})^2 = u^{\frac{10}{3}}.$$

$$\therefore \frac{dy}{dx} = \frac{5}{3} \frac{u^4}{u^{\frac{10}{3}}} \frac{du}{dx} = \frac{5}{3} u^{\frac{2}{3}} \frac{du}{dx},$$

as stated above.

By precisely similar steps, the formula for  $u^n$  can be proved to work in the case of any fractional power  $y = u^{p/q}$ .

Irrational quantities can therefore be differentiated by first writing them as fractional powers.

Ex. I.  $y = \sqrt{58-x^2}, = (58-x^2)^{\frac{1}{2}}$

$$\frac{dy}{dx} = \frac{1}{2} (58-x^2)^{-\frac{1}{2}} (-2x) = \frac{-x}{\sqrt{58-x^2}}.$$

Ex. II.  $y = \sqrt{6x^3}, = \sqrt{6} x^{\frac{3}{2}}$

$$\frac{dy}{dx} = \sqrt{6} \cdot \frac{3}{2} x^{\frac{1}{2}} (1) = \frac{3\sqrt{6}x}{2}.$$

Ex. III. Problem 10, p. 121, involves finding the minimum value of a function like the following:

$$y = \frac{\sqrt{x^2+24}}{5} + \frac{180-x}{7};$$

*i.e.*, 
$$y = \frac{1}{5}(x^2+24)^{\frac{1}{2}} + \frac{1}{7}(180-x).$$

Here 
$$\frac{dy}{dx} = \frac{1}{10}(x^2+24)^{-\frac{1}{2}}(2x) - \frac{1}{7},$$

$$= \frac{x}{5\sqrt{x^2+24}} - \frac{1}{7}.$$

Equating this to zero (§ 65), transposing, squaring, etc., we find

$$x = 5, \quad y = \frac{7}{5} + 25 = 26\frac{2}{5}.$$

Testing  $dy/dx$  at 4 and 6 shows this value of  $y$  to be a minimum.

§ 82. Abrupt Extremes. The graph of

$$y = x^{\frac{2}{3}} + 1$$

falls sharply to a minimum height of 1 at  $x=0$ , and then rises sharply. (Fig. 41.) It does not have a horizontal tangent at the lowest point.

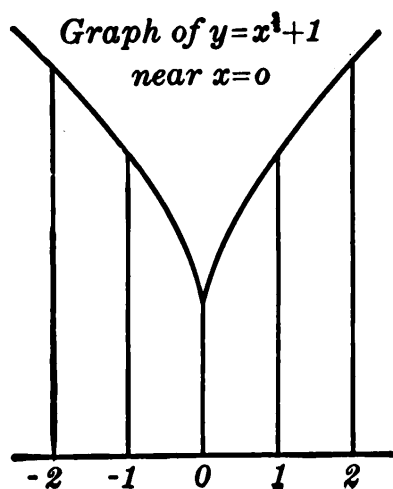

FIG. 41.

As always, the slope  $dy/dx$  is negative just before the minimum and positive just after it. But here  $dy/dx$  changes from  $-$  to  $+$  by “jumping,” — not by going through zero. The slope becomes indefinitely great, positively on one side and negatively on the other, as we approach the point. The “derived curve” (§ 72) would have a break at  $x=0$ , though there is no break in the original graph.

The only powers of  $x$  which allow this combination at a maximum or minimum are fractional powers.

## EXERCISES

1. What is the meaning of:  $x^{\frac{4}{3}}$ ,  $x^{\frac{1}{2}}$ ,  $x^{-\frac{1}{3}}$ ,  $x^{-\frac{5}{2}}$ ?
2. Differentiate each of the powers in Ex. 1, and express the results in a form free from fractional powers.
3. Express as powers, and then differentiate:

$$y = \sqrt[3]{x^5}, \quad y = 7\sqrt{x^3}, \quad y = 10/\sqrt{x}, \quad y = 20/\sqrt[3]{x^2}.$$

4. In Ex. 11, p. 45, find how fast  $T$  increases with  $L$  at  $L = 9$ . About how much longer does a 9.1-inch pendulum require to swing than a 9-inch pendulum?

5. In Ex. 7, p. 50, find about how much a planet's time of revolution would increase if  $x$  increased from 1.52 to 1.54.

6. The volume of water ( $V$  gal./hr.) flowing through a pipe of any radius ( $r$  in.) under a certain pressure is  $V = 630 r^{\frac{5}{2}}$ . About how much greater is  $V$  if  $r = 4.06$  than if  $r = 4$ ?

7. The distance of the horizon at sea ( $D$  mi.) varies thus with the observer's elevation ( $E$  ft.) above the water:  $D = 1.22 E^{\frac{1}{2}}$ . Approximately what change in  $D$ , if  $E$  increases from 100 to 102?

8. In Ex. 10, p. 45, how fast does  $V$  increase with  $s$  at  $s = 100$ ?

9. Differentiate the following fractional powers of quantities (§ 77):

$$\begin{array}{lll} (a) y = (x^3 + 1)^{\frac{7}{2}}, & (b) y = (x^4 - 7)^{\frac{5}{2}}, & (c) y = \sqrt{100 - x^6}, \\ (d) z = 51\sqrt{16 - x^2}, & (e) s = 8\sqrt[3]{175 - x}, & (f) u = 16\sqrt[4]{x^2 - 10x + 7}, \\ (g) y = \frac{20}{\sqrt{x^6 + 1}}, & (h) z = \frac{-15}{4(t^2 + 1)^{\frac{3}{2}}}, & (i) w = \frac{200}{9\sqrt[3]{25 - t^6}}. \end{array}$$

10. Two towns  $A$  and  $B$  are 44 mi. apart on a straight coast; an island  $C$  is 12 mi. out, directly off  $A$ . The trip from  $C$  to  $B$  is to be made by a launch and auto, meeting somewhere along the shore, say  $x$  mi. from  $A$ . If the launch goes 12 mi./hr. and the auto 20 mi./hr., what is the shortest possible time for the trip?

11. Plot  $y = 7 - x^{\frac{3}{2}}$  from  $x = -8$  to  $x = 8$ . (Take  $x = 8, \frac{32}{9}, 1, \frac{1}{9}$ , etc.) Note the maximum.

12. Plot another graph showing how  $dy/dx$  varies with  $x$  in Ex. 11.

**§ 83. Differential Notation.** In some work it is convenient to be able to deal with a derivative  $dy/dx$  as a fraction  $dy \div dx$ . This can be done by giving suitable meanings to  $dy$  and  $dx$  separately:

Let  $dy$  and  $dx$  denote any two quantities, large or small, whose ratio  $dy \div dx$  equals the derivative  $f'(x)$  or  $dy/dx$ . That is,

$$\frac{dy}{dx}, \text{ derivative} = \frac{(dy)}{(dx)}, \text{ fraction.} \quad (28)$$

The quantities  $dy$  and  $dx$  are called *differentials*.

An equation like

$$\frac{dy}{dx} = 3x^2 \quad (29)$$

may now be written also in the form

$$dy = 3x^2 dx, \quad (30)$$

by simply multiplying through by  $dx$ .

Treating a derivative as a fraction allows great freedom of operation. For instance, a product like

$$\frac{dy}{du} \cdot \frac{du}{dx}$$

may be simplified by merely canceling  $du$ . The value  $(dy/dx)$  thus obtained is correct by the theorem on indirect dependence, (21), p. 110.

Differentials are used very extensively in more advanced courses. Here, however, we merely need to know their meaning and the fact that a differential equation like (30) above is only another way of expressing the value of a derivative, as in (29).

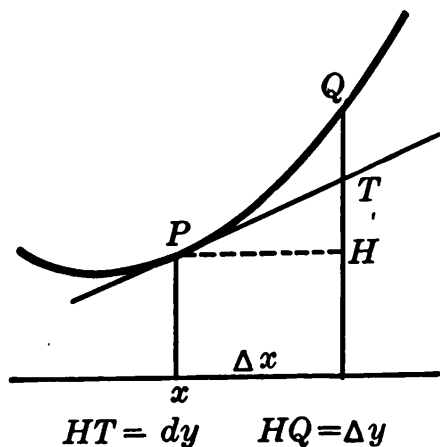

FIG. 42.

The following concrete interpretations of differentials may, nevertheless, be of interest.

**§ 84. Interpretations of Differentials.** In Fig. 42 the ratio of  $HT$  to  $PH$  equals the rate at  $P$ , — *i.e.*, equals  $f'(x)$ . Hence  $HT$  and  $PH$  may be taken as  $dy$  and  $dx$ , respectively.

Now  $HT$  is the amount that  $y$  would increase while  $x$  in-

creased by  $PH$  if the rate remained constant. Hence we may say :

*The differential of a function  $y$  is the amount that  $y$  would increase while  $x$  increased by any amount ( $dx$ ) if the rate remained the same as at the instant considered.*

Moreover, if  $dx$  is small,  $dy$  is nearly equal to  $\Delta y$  (or  $HQ$ ). But by (28),  $dy = f'(x)dx$ . Hence  $\Delta y$ , the small change in  $y$  produced by a small increase in  $x$ , is approximately equal to the derivative times the latter increase. (Cf. § 62.)

## EXERCISES

1. Differentiate the following, finding  $dy$  :

$$y = x^2, \quad y = x^{-4}, \quad y = 4x^{\frac{5}{2}}, \quad y = x^8 - 7x^5 + 3 - 10/x.$$

2. Write the differential of  $V$ , if  $V = x^3$ . Verify that either  $dV/dx$  or  $dV/dt$  is obtainable correctly from this by simply dividing.

3. Simplify by inspection :

$$\frac{dV}{dx} \cdot \frac{dx}{dt}, \quad \frac{dS}{dr} \cdot \frac{dr}{dt}, \quad \frac{dy}{du} \cdot \frac{du}{dx}, \quad \frac{dp}{dv} \cdot \frac{dv}{dt}.$$

4. By what would you multiply  $\frac{dy}{dx}$  to get  $\frac{dy}{dt}$ ?

$$\frac{dr}{ds} \text{ to get } \frac{dr}{dx} \quad \frac{dV}{dr} \text{ to get } \frac{dV}{dt} \quad \frac{dy}{dx} \text{ to get } \frac{dy}{ds}?$$

5. Express in an equivalent form each of these statements :

$$dy = x^4 dx, \quad dx = 3t^5 dt, \quad dV = 4\pi r^2 dr.$$

**§ 85. Summary of Chapter III.** To find the rate at which any given quantity is increasing at any instant, we have merely to find its *derivative*, — *i.e.*, to differentiate.

The derivative is defined abstractly as a certain *limit*, but it may have various concrete interpretations, such as instantaneous rate, slope, speed, etc.

Derivatives can often be written at sight. In such cases it is easier to find instantaneous rates than average rates. (Cf. § 33, Remark.) Indirect differentiation with respect to a third variable, say  $t$ , is possible. This introduces an extra factor,  $dx/dt$ .

The *amount* of change in  $y$  while  $x$  changes by a small  $dx$  is approximately  $dy$  or  $f'(x)dx$ . The effect of an error of measurement can be estimated in this way.

To locate the maximum and minimum values of any quantity, we set its derivative equal to zero, and test the same derivative before and after. (We also see whether the derivative can change from  $+$  to  $-$ , or *vice versa*, by "jumping.") In practical problems it is first necessary to obtain a formula for the quantity to be maximized or minimized, — and express this in terms of a *single variable*.

To find when a quantity is increasing most rapidly, — *i.e.*, at the greatest rate, — requires repeated differentiations. So do various problems on acceleration, flexion, etc.

Observe that although we can find the *slope* of a tangent line, we cannot as yet find its *inclination*, — *i.e.* the *angle* at which it rises from the horizontal. This problem will be treated later. (§ 111.)

### EXERCISES

1. What is meant by the derivative of  $y$  with respect to  $x$ ? Explain its significance as slope, rate, and speed.

2. Differentiate  $y = x^3 - 10x + 5$  by the  $\Delta$  process.

3. Differentiate at sight:

(a)  $y = x^5 + \frac{1}{2}x^4 - x^3/6 + 4$ ;

(b)  $z = 12\sqrt[3]{x^5} + 2/\sqrt{x}$ ;

(c)  $y = \sqrt{t^2 + 20t + 85}/30$ ;

(d)  $w = 5/x^4 - 7/(10 - x^2)^2$ .

4. A rectangular box is to contain 60 cu. ft. The materials for the base cost 30¢ per sq. ft., for the sides 10¢ per sq. ft., and for the top 20¢ per sq. ft. What is the smallest possible total cost, and what dimensions will give it?

5. The space within a quarter-mile running track consists of a rectangle with a semicircle at each end. To make the rectangle as large as possible, how much of the quarter-mile (440 yd.) should be given to the straight sides and how much to the curved ends?

6. The radius of a sphere is increasing at the rate of .04 in./hr. How fast is the volume increasing at the instant when  $r = 30$ ?

7. The volume of a cube is increasing at the rate of 12 cu. in./min. How fast is the total area increasing when the edge equals 20 in.?



8. The edge of a cube is measured as 20 in. If this may be erroneous by .02 in., about how inaccurate may the calculated volume be?

9. The radius of a sphere is measured as 5 in. About how accurate must this measurement be, if the calculated volume is not to be erroneous by more than 10 cu. in.?

10. The height of a certain curve is  $y = 20x^4 - x^5$ . Find where the slope is a maximum and where the flexion is increasing most rapidly.

11. Plot the curve  $y = x^4 + 12x^3 + 2$ , showing any points of maximum or minimum height or slope. What is the flexion at  $x = 1$ ?

12. The speed of an object varied thus:  $v = 20t^3 - t^4$ . Find when the acceleration was increasing most rapidly, and how rapidly then.

13. A baseball is batted along the third-base line, going 60 ft./sec. How fast is its distance from first base changing one half second after it started? How fast when passing third base?

14. In Ex. 10, p. 118, change the rate of the eastbound train to 60 mi./hr., and of the other to 25 mi./hr., and solve.

15. In Ex. 14, find when the trains were nearest.

16. In each of the following, first write a formula for the variable quantity, or function, in question; then find the required rate.

(a) The velocity of flow of a gas escaping through a small hole varies inversely as the square root of the diameter,  $D$  in. If  $V = 80$  cu. in./hr. when  $D = .01$ , find how fast  $V$  changes, at  $D = .04$ .

(b) The "moment of inertia,"  $I$ , of a flat circular disk varies as the fourth power of the radius. If  $I = 20$  when  $r = 2$ , find how fast  $I$  increases with  $r$ , at  $r = 5$ .

(c) In a railway curve the elevation of the outer rail should vary inversely as the radius. If  $E = 2.5$  (in.) when  $R = 3000$  (ft.), find how fast  $E$  changes, at  $R = 3600$ .

17. A bullet was fired straight upward, its height after  $t$  sec. being  $y = 1600t - 16t^2$ . How fast did it start up? What was its greatest height? When did it strike the ground, and with what speed?

[18.] The height of a ball  $t$  sec. after being thrown straight up was  $y = 20 + 80t - 16t^2$ . Show that the acceleration =  $-32$  ft./sec.<sup>2</sup> constantly. What terms in this formula might have been different without modifying this result? Write some other formulas to illustrate this.

[19.] A ball rolls up an incline, its distance from the bottom after  $t$  sec. being  $x = a + bt - 5t^2$ . Show that the acceleration =  $-10$  ft./sec.<sup>2</sup>. For what values of  $a$ ,  $b$ , would  $x$  equal 10 and the speed 100 at  $t = 0$ ?

[20.] The speed of an object after  $t$  seconds varied thus:  $v = 60t^2 - 4t^3$ . Can you find the distance traveled at any time?

## CHAPTER IV

### INTEGRATION

#### THE RATE PROBLEM REVERSED

§ 86. **Differentiation Reversed.** We have seen how to find the rate at which a given quantity is changing at any instant.

Consider now the reverse problem :

*Given the rate at which a quantity is changing, to find how large the quantity will be at any time.* (Of course, we must also know how large it was at some particular time.)

If the given rate is constant, the problem is merely one of arithmetic. But if the rate varies, we must in general proceed as follows :

The given rate is the derivative of the quantity whose value is required. Hence we are *given the derivative* of a function, and are to *find the function itself*. That is, we must reverse the differentiation process.\*

Ex. I. A bomb was dropped from an airplane 8000 ft. high:  $t$  seconds later its height ( $h$  ft.) was decreasing at the rate of  $32 t$  (ft./sec.). Find the height at any instant.

The given rate or derivative is

$$\frac{dh}{dt} = -32 t. \quad (\text{Why } -?)$$

To find  $h$ , then, we must think of some function which, if differentiated, would give  $-32 t$ . One such function is

$$h = -16 t^2.$$

\* Of course we might solve the problem approximately by some graphical method. See Ex. 11, p. 131.

But there are others. For instance,  $h = -16t^2 + 500$ , and  $h = -16t^2 - 40$ , both have this same derivative  $-32t$ . So does

$$h = -16t^2 + C, \quad (1)$$

$C$  being any constant whatever, positive or negative.

In other words, the given rate of change of  $h$  does not by itself determine the value of  $h$  at any time. But we were told also the height of the bomb at the start, viz.  $h = 8000$  at  $t = 0$ , when we began to count time. This fact requires the constant  $C$  in (1) to have the value 8000; and (1) becomes

$$h = -16t^2 + 8000. \quad (2)$$

*Check:* This formula is a correct solution of our problem. For at  $t = 0$  it reduces to  $h = 8000$ , and by differentiation  $dh/dt = -32t$ , the specified rate.

It is instructive to compare the foregoing problem with one in which the given rate is constant:

Ex. II. A captive balloon is being pulled down at the rate of 50 ft./min. How high will it be  $t$  min. hence?

Evidently,  $h = C - 50t$ , where  $C$  denotes the present height, whatever that may be. In other words,  $C$  is the value of  $h$  at  $t = 0$ , when we begin to count time.

In each problem *the value of  $h$  at any instant is completely determined by the original value and the rate of change at all times.*

**§ 87. Integration.** The process of reversing a differentiation and finding the original function, when given its derivative, is called **integration**. And the required original function is called the **integral** of the given derivative.

When integrating, we must always add an arbitrary constant  $C$ . For the given *rate* determines only the *amount of increase*. And the total value of the function at any time equals this increase *plus the original value*.

The value of this added "constant of integration" becomes definite if the value of the function is known at some instant or point. For instance, in Ex. I of § 86, the value of

$C$  was determined by the fact that  $h = 8000$  at  $t = 0$ . Another illustration follows.

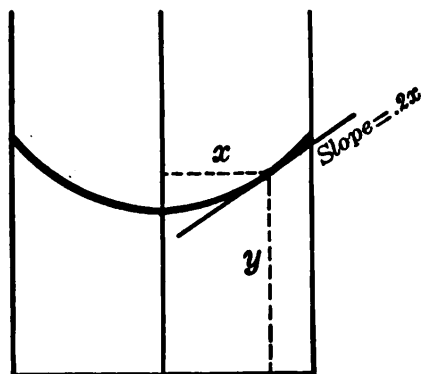

FIG. 43.

Ex. I. The water in a rotating pail, of radius 5 in., has its upper surface hollowed out, forming a curve whose slope at any distance  $x$  in. from the axis of rotation is  $.2x$ .\* (Fig. 43.) If the water is 8 in. deep at the highest point, find its depth at any other point.

We are to find  $y$  as a function of  $x$ , having given

$$\frac{dy}{dx} = .2x, \quad \text{and } y = 8 \text{ when } x = 5.$$

We therefore seek a function which, if differentiated, would give  $.2x$ . One such function is  $.1x^2$ . But any constant might be added, making

$$y = .1x^2 + C. \quad (3)$$

By the problem, however,  $y = 8$  when  $x = 5$ . In (3) this gives

$$\therefore 8 = .1(5)^2 + C,$$

or  $C = 5.5$ . And hence the required depth at any distance  $x$  in. from the center is

$$y = .1x^2 + 5.5.$$

*N.B.* Even here  $C$  is the value of  $y$  at  $x = 0$ , as substitution would show.

### EXERCISE

[1.] Find by inspection a function which if differentiated will give  $dy/dx = x^3$ . (Check your answer.) Likewise for  $dy/dx = x^{10}$ , and  $x^n$ . Hence, integrating  $x^n$  with respect to  $x$  will give what result?

§ 88. **Integration Formula.** To save labor let us systematize the integration process.

Differentiating any power of  $x$  leads to the next lower power. Hence integrating leads to the next higher. Thus

$$\frac{dy}{dx} = x^n \quad \text{gives} \quad y = \frac{x^{n+1}}{n+1} + C. \quad (4)$$

\* It is shown in Physics, by considering the forces involved, that for any constant speed of rotation, the slope must equal *some* constant times  $x$ .

The coefficient  $1/(n+1)$  is required to cancel the multiplier  $(n+1)$  which would come from the exponent in differentiating.

By this formula, we can integrate various powers at sight. Thus

$$\frac{dy}{dx} = x^{10} \quad \text{gives} \quad y = \frac{x^{11}}{11} + C;$$

$$\frac{dy}{dx} = x^{-4} \quad \text{gives} \quad y = \frac{x^{-3}}{-3} + C;$$

$$\frac{dy}{dx} = x^{\frac{1}{2}} \quad \text{gives} \quad y = \frac{x^{\frac{3}{2}}}{\frac{3}{2}} + C.$$

These last two results can be simplified, giving

$$-\frac{1}{3x^3} + C, \quad \text{and} \quad \frac{2}{3} x^{\frac{3}{2}} + C.$$

These integrations should be checked by differentiating the results.

Formula (4) fails, however, if  $n = -1$ . For then  $n+1=0$  and cannot be used as a divisor. (It is clear anyhow that  $x^{-1}$  could not be obtained by differentiating the next higher power  $x^0$ .) The integral of  $x^{-1}$  must be some other kind of function, not a power of  $x$ . (Treated in § 178.)

*Remark.* The effect of a constant multiplier is simply to multiply the resulting integral by the same factor. For instance:

$$\frac{dy}{dx} = 20x^6 \quad \text{gives} \quad y = 20\left(\frac{x^7}{7}\right) + C.$$

But to integrate the product of two *variable* factors we must first multiply out. (Cf. § 60.)

To integrate the *sum* of several terms, we integrate term by term. It is unnecessary to introduce a constant for each term integrated. For a single  $C$  can have any value whatever, — say the sum of the values which several  $C$ 's might have.

**§ 89. Uniqueness.** If to an integral of a given derivative any constant be added, the result will still be an integral. For the constant would disappear on differentiating.

But may there not be some entirely different function which would also be an integral, — perhaps a very complicated function, whose derivative would simplify down to the given quantity? No, this is impossible. In other words:

*Two functions which have the same derivative can differ only by a constant.*

For if the derivatives are equal, the functions must be changing at the same rate; and hence their difference is not changing but remains constant. One function equals the other plus a constant.

Thus an integration can give only one result, aside from the possibility of an added constant.

### EXERCISES

1. Given each of the following values for  $dy/dx$ , find  $y$  itself, including the arbitrary constant. Check each answer by differentiation.

(a)  $dy/dx = x^8, x^5, x, 5x^2, -\frac{2}{3}x^4, \frac{5}{2}x, 20, -8,$

(b)  $dy/dx = x^{\frac{5}{2}}, x^{\frac{4}{3}}, x^{\frac{1}{2}}, 7x^{\frac{1}{3}}, \frac{4}{3}\sqrt{x}, -\frac{7}{3}\sqrt[3]{x}, 28\sqrt{x^5} + 2,$

(c)  $dy/dx = x^{-6}, x^{-4}, 1/x^2, 5/x^6, -2/x^3, k/x^{11}, -7/2 x^8 + k,$

(d)  $dy/dx = x^{-\frac{5}{3}}, x^{-\frac{7}{2}}, x^{-1.41}, 1/\sqrt{x}, -5/\sqrt[3]{x}, 12/\sqrt{x^7}, k/\sqrt[4]{x^8}.$

2. Similarly find  $y$  if  $dy/dx = 5x^3 - 9x + 10\sqrt{x} - 4 + 9/x^2$ .

3. In the following, find  $y$  as a definite function of  $x$ , determining the constant of integration:

(a)  $dy/dx = x^4 - 7x + 10,$  and  $y = 100$  at  $x = 0,$

(b)  $dy/dx = (\sqrt{x} + 25 - 6x^3),$  and  $y = 50$  at  $x = 1.$

4. If  $dV = x^4 dx$  and  $V = 0$  when  $x = 10$ , express  $V$  as a function of  $x$ .

5. The weight of a column of air whose cross section is 1 sq. ft. and height is  $h$  ft. increases with  $h$  approximately as follows:  $dW/dh = .0805 - .00000268h$ . Express  $W$  as a function of  $h$ , knowing that  $W = 0$  when  $h = 0$ . Find the weight of a column 10,000 ft. high.

6. The slope of a certain suspension cable at any horizontal distance  $x$  ft. from the center is  $.004x$ . Find the height ( $y$  ft.) at any point

if  $y=20$  at  $x=0$ . Plot the curve from  $x=-80$  to  $+80$ , at intervals of 20.

7. In Ex. I, § 87, change the slope to  $.3x$  and the depth at the center to 4 in., and find  $y$  at any point. Plot from  $x=-3$  to  $+3$ .

8. The speed of a car  $t$  sec. after starting was  $60t^2 - 4t^3$ . Find a formula for the distance ( $y$ ) traveled at any time. Calculate  $y$  when  $t=10$ .

9. When a car had run for  $t$  sec., its momentum  $M$  was increasing at a rate equal to  $(3t^2 + 2t)$ . Find  $M$  at any time; at  $t=10, 20, 30$ .

10. At a certain instant a quantity had the value 500, and  $t$  min. later it was increasing at the rate of  $.6t^2$ . Find its value at any time.

11. Table I shows the rate ( $R$  lb. per hr.) at which a piece of ice was melting  $t$  hours after being cut. Find the total amount which melted during the five hours. (Hint: Plot a graph whose height shall represent the rate of melting at any instant. What, then, will represent the average rate during any hour?)

TABLE I

$t$	$R$	$t$	$R$
0	0	3	21
1	9	4	24
2	16	5	25

12. In Ex. 11 the formula for  $R$  at any time is  $R=10t-t^2$ . Calculate the quantity melted from  $t=0$  to  $t=5$ , and check your graphical result. (Hint: What relation has the given rate  $R$  to the *quantity*?)

**§ 90. Repeated Integrations.** In some practical problems it is necessary to integrate several times in succession.

To determine the value of the constant of integration which enters at each step, we must know the numerical value, at some instant or point, of the quantity represented by the integral obtained at that step, — say, flexion, slope, or height of a curve; or acceleration, speed, or distance traveled by a moving object; etc.

§ 91. **Projectiles, Thrown Vertically.** When an object is thrown straight upward, its speed  $v$  decreases by 32 ft./sec. in each second.\* Thus if the speed is 140 ft./sec. at the start, after 1 sec. it will be 108 ft./sec.; etc. (See table.) After 5 sec. the object will be *falling* with a speed of 20 ft./sec., then 52 ft./sec., etc. Calling these downward speeds negative, we can say that  $v$  is still decreasing algebraically, though increasing numerically.

$t$	$v$
0	140
1	108
2	76
3	44
4	12
5	-20
6	-52

That is, *the acceleration* or rate of change of  $v$ , is  $-32$  ft./sec<sup>2</sup>. *whether the object is rising or falling.*

To express this fact mathematically, recall that the speed is the rate at which the height ( $y$  ft.) is changing:  $v = dy/dt$ , whence the acceleration is

$$\frac{d^2y}{dt^2} = -32. \quad (5)$$

By remembering this one simple equation, we can solve all ordinary problems concerning vertically thrown projectiles, if we understand the process of integrating. Separate formulas for upward and downward motion, as commonly used in elementary physics, are unnecessary.

Ex. I. A bomb was thrown straight down from a height of 2000 ft. with an initial speed of 80 ft./sec. Find its height  $t$  sec. later.

Integrating (5) gives the speed at any time:

$$\frac{dy}{dt} = -32t + C.$$

But the speed was  $-80$  at the start: *i.e.*,  $dy/dt = -80$  at  $t=0$ . Hence  $C = -80$ .

$$\therefore \frac{dy}{dt} = -32t - 80. \quad (6)$$

Integrating again:

$$y = -16t^2 - 80t + k.$$

\* See Remark I, § 24. Obliquely thrown projectiles are discussed in §§ 191, 222.



But the height at the start was  $y=2000$ . Hence  $k=2000$ . Thus, finally,

$$y = 2000 - 80t - 16t^2. \quad (7)$$

Observe the physical meaning of this result: ~~The height at any instant~~ equals the original height (2000) minus the distance ( $80t$ ) the bomb would have fallen in  $t$  seconds if it had kept on at the original speed (80 ft./sec.), and minus also the distance ( $16t^2$ ) that gravity would pull it down in  $t$  seconds starting from rest.

### EXERCISES

1. Point out the physical meaning of formula (6) above, as has just been done for formula (7).

*In each of the exercises 2, 4, 5, 6, 10, 11, below, after getting the formulas for  $dy/dt$  and  $y$ , point out the physical meanings of the terms in each.*

2. A ball was thrown straight up from a roof 60 ft. high with an initial speed of 80 ft./sec. Find its height after  $t$  seconds, and also when it struck the ground.

3. On a vertical line mark and label the positions of the ball in Ex. 2 after 1 sec., 2 sec., etc., until it struck. Also plot a graph showing how  $y$  varied with  $t$  during the flight.

4. A projectile was fired straight up from an airplane 2000 ft. high with an initial speed of 1600 ft./sec. Find when it was highest and how high. When did it pass a balloon 10,000 feet high?

5. A bomb was dropped from an airplane 3000 ft. high. When did it strike the ground and with what speed?

6. The same as Ex. 5 if the bomb was thrown down with an initial speed of 50 ft./sec.

7. In Ex. 6 mark on a vertical line the positions of the bomb after 1 sec., 2 sec., etc., until it struck.

8. A point on the rim of a flywheel was moving at the speed of 60 in./sec. when the power was cut off. The speed thereafter decreased at the rate of 4 in./sec<sup>2</sup>. Find when the wheel stopped and how far the point moved in stopping.

9. The same as Ex. 8, if the rate of decrease was 6 ft./sec<sup>2</sup>, and the original speed 75 ft./sec.

10. A ball was thrown straight up from a window 96 ft. high, with an initial speed of 60 ft./sec. Express the height after  $t$  seconds. When was the ball highest and how high? When did it reach the ground, and with what speed?

11. A bomb dropped from an airplane struck the ground in 10 sec. How high was the plane?

12. The acceleration of a point on the rim of a flywheel was  $d^2y/dt^2 = .3t - .01t^2$ , where  $y$  is in feet. Express  $y$  as a function of  $t$  if the wheel starts from rest. Find the maximum speed, and the distance traveled before reaching that speed.

13. For a beam loaded in a certain way, the flexion at any point is  $d^2y/dx^2 = -.00001(x^2 + 21x - 108)$ . Express  $y$  in terms of  $x$ , if  $y = 0$ , and slope = .00288 at  $x = 0$ .

14. Find the distance ( $y$  ft.) traveled by an object in  $t$  sec., if the speed was 100 and the acceleration  $-30$  at  $t = 0$ , and if  $d^3y/dt^3 = 120 - 24t$  at any time.

15. Find  $y$  if  $dy = (x^{12} - 3x^2 + 7 - 1/\sqrt{x^3} + 5/x^4)dx$  and  $y = 0$  when  $x = 1$ .

[16.] Plot  $y = x^2$  from  $x = 0$  to  $x = 4$ . Measure approximately the area  $A$  under the curve from  $x = 0$  to  $x = 2$ . About how much larger would  $A$  be if it reached to  $x = 2 + \Delta x$ ,  $\Delta x$  being very small? If the right boundary is moving along, how fast is  $A$  increasing, at  $x = 2$ ? At any value of  $x$ ? [Ans.,  $dA/dx = x^2$ .] From this result can you find the value of  $A$  to any boundary ( $x$ )?

§ 92. **Integral Notation.** The integral of any function  $F(x)$ , with respect to  $x$ , is denoted by the symbol

$$\int F(x)dx.$$

For instance,  $\int x^2 dx$  denotes the integral of  $x^2$  with respect to  $x$ .

$$\therefore \int x^2 dx = \frac{1}{3} x^3 + C.$$

This is usually read simply "The integral of  $x$  square —  $dx$ ."

In this notation the integration formula (4), p. 128, reads :

$$\int x^n dx = \frac{x^{n+1}}{n+1} + C. \quad (8)$$

This fails, however, if  $n = -1$  (p. 128). That case is treated later (§ 178).

A constant multiplier simply multiplies the result. *E.g.*,

$$\int 4 \pi r^2 dr = 4 \pi \int r^2 dr = \frac{4}{3} \pi r^3 + C.$$

Thus a constant factor can be moved from one side of the integral sign to the other. Variable factors, however, cannot be so moved, for a product of two variable factors cannot be differentiated by merely differentiating one factor.

Observe that the expression following the integral sign  $\int$  is in the *differential form* (§ 83). That is, the sign  $\int$  stands for a *quantity whose differential is whatever follows*.

Thus  $\int x^2 dx$  stands for the quantity whose differential is  $x^2 dx$ . But of course this is the same thing as the quantity whose derivative with respect to  $x$  is  $x^2$ .

§ 93. **A Growing Area.** Many geometrical and physical quantities can be calculated quickly and exactly by integration. The underlying idea is much the same in all cases. Let us consider first the typical case of the area under any given graph, — supposing of course that the graph is free from breaks, so that an area is actually bounded.

In Fig. 44 if  $CD$  is fixed and  $PQ$  moves to the right, the area  $A$  will vary with  $x$  in some definite way. If we can determine its *rate of increase*,  $dA/dx$ , we can find  $A$  by integrating.

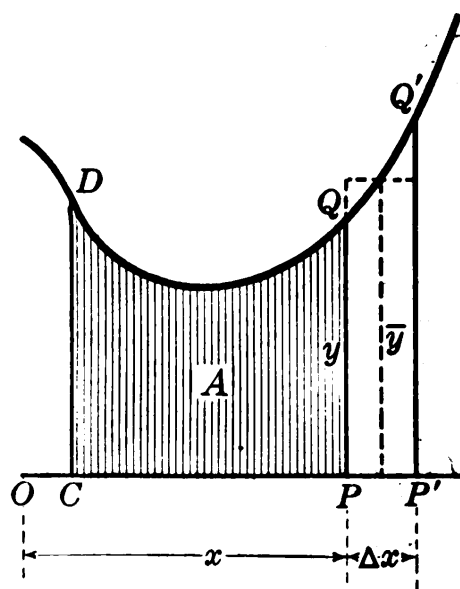

FIG. 44.

To get a vivid idea of the growing area  $A$  imagine a rubber sheet with one end fastened at  $CD$  and the other end  $PQ$  being pulled along, while the sides, attached to wires, constantly fit along the base line and the curve. The area of the stretching sheet is the "growing area"  $A$ , of which we are speaking.

While  $x$  increases by  $\Delta x$ ,  $A$  increases by

$$\Delta A, = \text{area of strip } PP'Q'Q, = \bar{y}\Delta x,$$

where  $\bar{y}$  is some average ordinate (read “  $y$  bar ”).

$$\therefore \frac{\Delta A}{\Delta x} = \bar{y}.$$

This is the average rate of increase of  $A$  per  $x$ -unit. Its limit is

$$\frac{dA}{dx} = \lim_{\Delta x \rightarrow 0} (\bar{y}) = \overline{PQ} = y. \quad (9)$$

( That is, *the rate at which the area  $A$  is increasing at any instant is equal to the height of the curve at that point.\** )

§ 94. **Areas Found Exactly.** Since the rate of growth of the area  $A$  in Fig. 44 is  $dA/dx = y$ , we have simply

$$A = \int y dx. \quad (10)$$

Thus we can find the area under any graph, if we know a formula expressing the height  $y$  at any point in terms of the horizontal distance  $x$  from some fixed point, and if we can integrate the expression  $y dx$ .

To illustrate, let us find the area under the curve  $y = x^3$  between a fixed ordinate erected at  $x = 1$  and a moving ordinate.

Equation (10) becomes in this case

$$A = \int x^3 dx = \frac{1}{4} x^4 + C. \quad (11)$$

This is our growing area, and it is to start at  $x = 1$ . That is,  $A = 0$  when  $x = 1$ .

Substituting these values in (11) gives

$$0 = \frac{1}{4}(1)^4 + C, \text{ or } C = -\frac{1}{4}.$$

Hence the required area from  $x = 1$  to any other value of  $x$  is simply

$$A = \frac{1}{4} x^4 - \frac{1}{4}.$$

\* This result is reasonable. For suppose the ordinate  $PQ$  to move say .001 inch to the right. Evidently the tiny strip added to the growing area  $A$  would be almost exactly .001  $y$  (sq. in.). The average rate of growth during this tiny interval would be practically  $y$  (sq. in. per horizontal inch). The instantaneous rate is exactly  $y$ .

*E.g.*, from  $x=1$  to  $x=3$ , we have  $A = \frac{1}{4}(3)^4 - \frac{1}{4} = 20$ . Likewise, from  $x=1$  to  $x=10$ ,  $A = \frac{1}{4}(10)^4 - \frac{1}{4} = 2499\frac{3}{4}$ . And so on.

If we wished an area under this curve starting at some other value than  $x=1$ , however, we should have to redetermine the constant  $C$  accordingly.

Observe, then, that we find an area between two fixed ordinates by regarding it as the value to which a varying area will grow, starting from one of the ordinates.

## EXERCISES

1. Plot from  $x=0$  to 10 a line whose height at any point is  $y=2x+5$ . Find by elementary geometry the area under it. Calculate the same area by integration.

2. Find by integration the area under the line  $y=3x+4$ , from  $x=2$  to 8. Can you check this result by geometry without plotting?

3. Find the area under the curve  $y=x^4$  from  $x=5$  to any other  $x$ ; from  $x=5$  to  $x=10$ .

4. Find the area under each of the following curves:

(a)  $y=x^3-6x+8$ , from  $x=2$  to 4;

(b)  $y=x^{10}-9x^2+11$ , from  $x=0$  to 1;

(c)  $y=\sqrt{x}$ , 4 to 9;

(d)  $y=\sqrt[3]{x}$ , 1 to 8;

(e)  $y=1/x^3$ , 2 to 5;

(f)  $y=1/\sqrt{x}$ , 1 to 4.

5. In a certain curve the height varies as the square of the horizontal distance  $x$  from a certain point, and is 15 at  $x=2$ . Find the area under the curve from  $x=1$  to 10.

6. Plot that part of the curve  $y=12x-3x^2$  in which  $y$  is positive. Calculate the area under it.

[7.] An object is moved against a force ( $F$  lb.) which varies thus with the distance  $x$  ft.:  $F=8x-x^2$ . Plot  $F$  as a function of  $x$  from  $x=0$  to  $x=8$ . Find graphically the work done from 0 to 8. Can you calculate this work exactly?

**§ 95. Momentum.** Consider the momentum  $M$  imparted to a moving object by a varying force in  $t$  seconds after starting. (§ 15.)

In an additional interval  $\Delta t$ , further momentum  $\Delta M$  is imparted. This equals the average force  $\bar{F}$  acting during  $\Delta t$ ,

multiplied by the time  $\Delta t$ :  $\Delta M = \bar{F}\Delta t$ . Hence the average rate of increase of  $M$  per sec. is

$$\frac{\Delta M}{\Delta t} = \bar{F}$$

As  $\Delta t \rightarrow 0$ ,  $\bar{F}$  approaches the value of  $F$  at the instant considered :

$$\therefore \frac{dM}{dt} = F.$$

$$\therefore M = \int F dt. \quad (12)$$

This agrees with our earlier statement (Ex. 6, p. 68) that  $M$  is represented by the area under a force-time graph. For  $y$  in that graph is  $F$  and  $x$  is  $t$ , so that the area  $A = \int y dx$  becomes  $A = \int F dt$ .

Ex. I. Find the momentum generated from  $t=3$  to any other instant if the force varies thus:  $F = 16 - .6 t^2$ .

By (12): 
$$M = \int (16 - .6 t^2) dt;$$

*i.e.*, 
$$M = 16 t - .2 t^3 + C.$$

And, since  $M = 0$  when  $t = 3$ , we find on substituting:  $C = -42.6$ .

**§ 96. Work.** Consider the work done by a variable force in moving an object any distance  $x$ .

In an additional distance  $\Delta x$ , additional work  $\Delta W$  is done. This equals the average force  $\bar{F}$  acting during  $\Delta x$ , multiplied by the distance :

$$\Delta W = \bar{F}\Delta x.$$

$$\therefore \frac{\Delta W}{\Delta x} = \bar{F}.$$

The instantaneous rate at which  $W$  is increasing is therefore :

$$\frac{dW}{dx} = F.$$

$$\therefore W = \int F dx. \quad (13)$$

This indicates that  $W$  is represented by the area under a force-distance graph. For there  $y = F$  and  $\int y dx$  becomes  $\int F dx$ . (Cf. Ex. 6, p. 28.)

§ 97. **Volumes.** Let Fig. 45 represent any solid, and let  $V$  be the volume between a fixed plane  $CD$  and a moving plane  $PQ$  at a varying distance  $x$  from some fixed point.

While  $x$  increases by  $\Delta x$ ,  $V$  increases by some  $\Delta V$ :

$$\Delta V = \text{volume of slice} \\ PP'Q'Q = \bar{A}\Delta x,$$

where  $\bar{A}$  ("A bar") is the average cross-section area in the slice. Hence the average rate of increase of  $V$  per  $x$ -unit is

$$\frac{\Delta V}{\Delta x} = \bar{A}. \\ \therefore \frac{dV}{dx} = \lim_{\Delta x \rightarrow 0} (\bar{A}), = \text{area } \overline{PQ} = A_s. \quad (14)$$

That is, the rate of increase of  $V$  at any instant equals the area of the cross-section  $A_s$ , at the point just reached.

$$\therefore V = \int A_s dx. \quad (15)$$

Hence we can find the volume of any solid, if we can do two things: (1) Express the area of a moving cross-section in terms of its distance  $x$  from some fixed point and (2) integrate the expression thus obtained.

Ex. I. Suppose the moving section in Fig. 45 to be a circle and its radius to vary thus:  $r = .05x^2$ . Find the volume between two planes  $CD$  and  $LK$  located at  $x = 3$  and  $x = 10$ , respectively.

$$A_s = \pi r^2 = \pi (.05x^2)^2 = .0025 \pi x^4.$$

$$V = \int .0025 \pi x^4 dx = .0005 \pi x^5 + C.$$

This is the growing volume between some fixed plane (to be taken

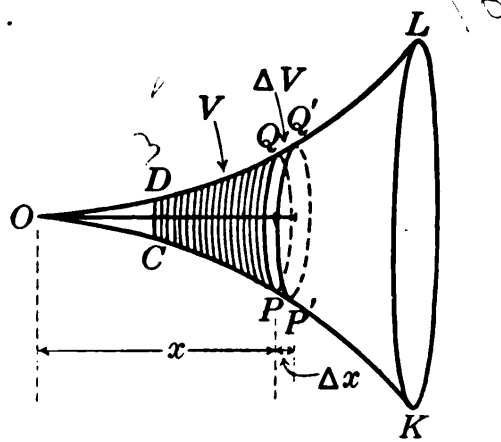

FIG. 45.

at  $CD$ ) and the moving plane  $PQ$ . When  $PQ$  was just starting from  $CD$ , the volume was zero:  $V=0$  at  $x=3$ .

$$\therefore 0 = .0005 \pi (3)^5 + C.$$

This requires  $C = -.1215 \pi$ ; and the growing volume is

$$V = .0005 \pi x^5 - .1215 \pi.$$

When  $PQ$  reaches  $LK$ ,  $x=10$  and  $V = 50 \pi - .1215 \pi = 156.7$  approx.

### EXERCISES

1. The force ( $F$  lb.) applied to an object varied thus:  $F = 120t - 6t^2$ . Find the momentum generated from  $t=1$  to  $t=4$ .

2. Like Ex. 1 for a force varying in each of these ways:

$$(a) F = 40t, \quad t = 5 \text{ to } 20; \quad (b) F = 3.6t + 20, \quad t = 0 \text{ to } 10;$$

$$(c) F = 125 - t^3, \quad t = 0 \text{ to } 5; \quad (d) F = 12\sqrt{t} + 15, \quad t = 1 \text{ to } 9.$$

3. The force ( $F$  lb.) required to stretch a certain spring  $x$  inches is  $F = 20x$ . Find the work done in stretching it from its normal length to an elongation of 5 in.

4. The force ( $F$  lb.) exerted on a piston varied thus with the distance  $x$  in. from one end of the cylinder:  $F = 120000/x^{\frac{1}{2}}$ . Find the work done from  $x=27$  to  $x=64$ .

5. The force ( $F$  dynes) with which two spheres carrying certain electrical charges will attract each other when their centers are  $x$  cm. apart is  $F = 20/x^2$ . Find the work done in moving them apart, from  $x=5$  to  $x=10$ .

6. The force  $F$  lb. with which the earth attracts a "1-lb. weight" at a distance of  $x$  mi. from its center is  $F = 16000000/x^2$ . Find the work necessary to drive such a weight from the earth's surface ( $x=4000$ ) to the distance of the moon ( $x=240000$ ). Ignore air resistance.

7. When an electron  $E$  is  $x$  cm. from a surface  $S$ , it is attracted toward  $S$  with a force ( $F$  dynes) given by the formula:  $F = 5.25(10^{-20})/x^2$ . Find the work necessary to draw  $E$  away from  $S$ , from  $x=3$  to  $x=15$ .

*In the following problems draw a rough figure for yourself even where one is shown.*

8. Every section of a certain horn perpendicular to its axis is a circle, whose radius varies thus with the distance  $x$  from one end:  $r = .04x^2$ . Find the volume of the space within the horn from  $x=10$  to  $x=20$ . (Cf. Fig. 45.)



9. Every horizontal section of a steeple  $x$  ft. from the top is a square, whose side  $s$  ft. varies thus:  $s = .01x^2$ . Find the volume, if the total height is 30 ft.

10. Every horizontal section of a solid is a rectangle, whose sides  $y$  and  $z$  vary thus with the distance ( $x$  in.) below the highest point:  $y = 14\sqrt{x}$ ,  $z = x^2/9$ . Find the volume from  $x = 0$  to  $x = 9$ .

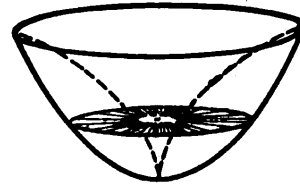
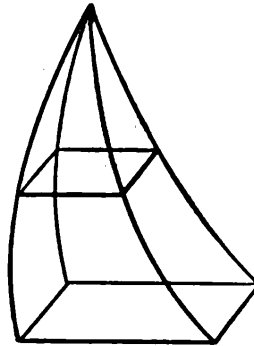

11. Every horizontal section of a solid is a ring between two concentric circles, whose radii ( $R$ ,  $r$  ft.) vary thus with the distance  $x$  ft. above the lowest point:  $R = \sqrt{x}$ ,  $r = x^2$ . Find the volume,  $x = 0$  to 1.

12. The base of a solid is a quarter circle of radius 10 in. (Fig. 46.) Every section parallel to one face is a right triangle, whose altitude equals 1.6 times its base. Find its volume.

(Hint: The area of the moving triangular section,  $.8y^2$ , must be expressed in terms of  $x$ . This is easy, since  $x$  and  $y$  are legs of a right triangle whose hypotenuse is the radius, 10 in.)

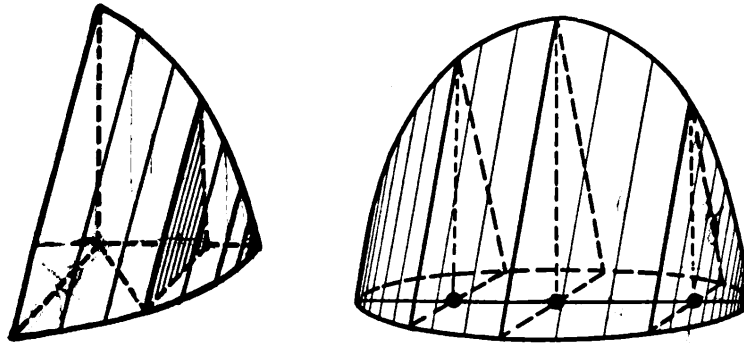

FIG. 46.

13. Find by integration the volume of a sphere of radius 10 in. Check by geometry. (Hint: What sort of section is made by any plane  $x$  in. from the center? What area,  $A$ ,?)

14. Find the volume of a segment cut from a sphere of radius 20 in. by a plane 10 in. from the center.

15. The base of a solid is a circle of radius 10 in., but every section perpendicular to one diameter is a triangle, whose height equals twice its base. Find the volume. (Has this solid any relation to the type of solid in Ex. 12? Cf. Fig. 46.)

§ 98. **Setting up the Area-formula.** In finding a volume the area  $A$ , can often be expressed immediately in terms of the dimensions of the moving section. But before integrating, this must be put in terms of  $x$ , the distance of the section from some fixed point. The transformation is often effected by the Pythagorean theorem or a proportion.

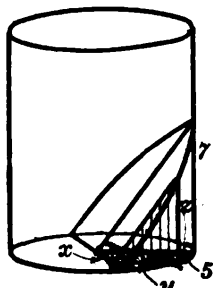

FIG. 47.

For instance, suppose we wish to find the volume of a wedge 7 in. high cut off from a cylinder of radius 5 in. by a plane passed through a diameter of the base. (Fig. 47.)

Any section perpendicular to that diameter is a right triangle. (Why?) Its area is

$$A_s = \frac{1}{2} yz. \quad (16)$$

But we must get this expressed in terms of  $x$ .

The radius, if drawn to the end of  $y$ , would form in the base plane a right triangle with legs  $x$  and  $y$ , and hypotenuse 5.

$$\therefore y = \sqrt{25 - x^2}. \quad (17)$$

Moreover, the vertical sectional triangle is similar to the central right triangle whose sides are 5 in. and 7 in. (Why?)

$$\therefore \frac{z}{y} = \frac{7}{5},$$

whence  $z = \frac{7}{5} y = \frac{7}{5} \sqrt{25 - x^2}$ .

Substituting the values of  $y$  and  $z$  in terms of  $x$  in (16) above gives

$$A_s = \frac{1}{2} \sqrt{25 - x^2} \cdot \frac{7}{5} \sqrt{25 - x^2} = \frac{7}{10} (25 - x^2).$$

This is now ready to integrate:

$$V = \int \frac{7}{10} (25 - x^2) dx = \frac{7}{10} (25x - \frac{1}{3} x^3) + C.$$

If we consider half the wedge, starting the "growing volume" at  $x=0$ , then  $C=0$ . The moving plane finally comes to  $x=5$ , making

$$V = .7(125 - \frac{1}{3} 125) = 1\frac{1}{3} 5 = 58\frac{1}{3}.$$

Doubling this gives the volume of the entire wedge.

*N.B.* Observe once more that the area which we integrate is not the area of some special fixed section (like the central triangle), but rather the area of a *general moving section*, expressed in terms of its distance  $x$  from some fixed point.

§ 99. **Original Meaning of  $\int$ .** When we write  $A = \int y dx$ , we mean that  $A$  is a quantity whose derivative with respect to  $x$  is equal to  $y$ .

But historically the sign  $\int$  was originally an  $S$ , denoting “*sum of.*” The area under a curve was regarded as composed of innumerable strips, — each having a tiny base  $dx$ , a practically constant height  $y$ , and an area  $y dx$ . (Fig. 48.) The whole area was the sum of these tiny “elements” of area, or, as then written :

$$A = \int y dx. \quad (18)$$

“The integral” originally meant simply “the whole,” and integration was the process of making whole. From this point of view formula (18) has a very tangible meaning.

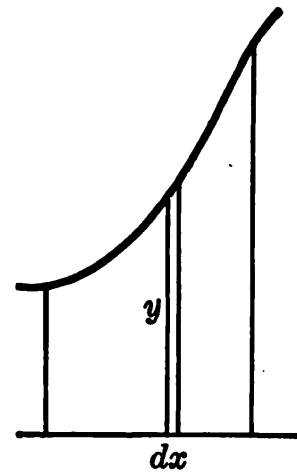

FIG. 48.

Unfortunately, however, this reasoning is a bit crude. No matter how narrow a strip may be, its area is not exactly  $y dx$ . To get the exact value of  $A$  from (18) it is necessary to use the sign  $\int$  not in the old sense of the sum of elements  $y dx$ , but as denoting the integral in the modern sense, — *i.e.*, a quantity whose derivative with respect to  $x$  is  $y$ .

The old conception, nevertheless, can be modified slightly so as to be free from logical objection. (This will be done in Chap. XII.) And, when properly understood, this idea of tiny elements will afford the simplest means of setting up

integral formulas. In fact, it is the method regularly used by scientific men. Some further illustrations will make the idea clearer.

(A) *Volume of a Solid.* According to the old conception, we may consider the solid as composed of exceedingly thin slices, say like a soap film, — so thin that the area of each face of the slice is the same. The volume of the slice is this area  $A_x$  (which depends on the distance  $x$  from some fixed point) multiplied by the thickness of the slice  $dx$ . The whole volume is the sum of these slices:

$$V = \int A_x dx.$$

This will give a strictly correct result, if we integrate instead of summing, as we know from (15) above.

(B) *Distance Traveled at a Varying Speed.* According to the old conception, we may consider so short an interval of time  $dt$  that the speed  $v$  remains constant. The distance traveled during this interval is  $vdt$ ; and the whole distance is the sum of all these tiny distances:

$$s = \int v dt.$$

If we integrate instead of summing, we get an exact value. For since the speed is the derivative of the distance, the distance is the integral of the speed.\*

(C) *Work Done by a Variable Force.* According to the old conception, we may consider so short a distance  $dx$  that the force is constant. The work done in this tiny distance is  $Fdx$ ; and the sum of all these little bits of work is

$$W = \int F dx.$$

This formula, too, as we know by (13), gives an exact value if we integrate instead of summing.†

\* Observe that this integral is also precisely the one which would have to be calculated, if we wished to find the area under the speed-time graph, for there  $v$  takes the place of “ $y$ ” and  $t$  the place of “ $x$ .” That is, the distance is represented exactly by the area under the speed-time graph. Cf. § 14.

† Why this crude reasoning, despite its fallacy of considering certain variable quantities as temporarily constant leads to these formulas which are strictly exact when we interpret the sign  $\int$  in the modern sense, will become clear in Chap. XII. We shall also see how to tell when this reasoning can be relied upon.

## EXERCISES

1. If the height of a cone is 10 in. and the radius of the base is 5 in., what is the area of a horizontal section  $x$  in. from the vertex? Calculate the volume by integration, and check by geometry.

2. The same as Ex. 1, for a cone of height 24 and radius 7.

3. The same as Ex. 1, for a cone of any height  $h$  and radius  $r$ .

4. Draw the curve  $y = x^2$ , roughly. Calculate the volume which would be generated by revolving the area under this curve about its base-line from  $x = 0$  to  $x = 10$ . (Hint: What sort of figure will any section perpendicular to the base-line be? With what radius?)

5. The same as Ex. 4, for the line  $y = 2x + 5$  from  $x = 1$  to  $x = 4$ .

6. Find by integration the volume of a sphere of radius 20 inches; also the volume cut off from that sphere by a plane 12 inches from the center.

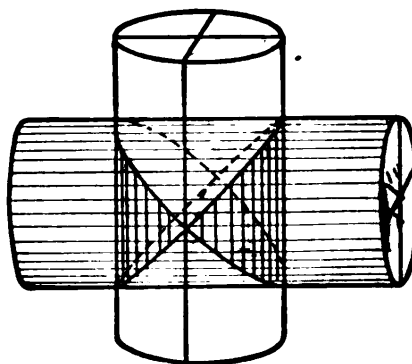

7. Every horizontal section of a pier 50 ft. high is a square whose side increases uniformly from 10 ft. at the top to 20 ft. at the bottom. Calculate the sectional area 10 ft. from the top, 20 ft. from the top, etc., and find graphically the volume of the pier.

8. Find the volume of the pier in Ex. 7 by integration.

9. Find the volume of a wedge 4 in. high cut from a cylinder of radius 5 in. by a plane passing through a diameter of the base.

10. The same as Ex. 9, if the wedge has any height  $h$ , and the cylinder any radius  $r$ .

11. The base of a solid is a quarter-circle of radius 6 in. Every section parallel to one vertical face is a right triangle whose altitude is twice its base. Find the volume of the solid.

12. Find the volume common to two equal cylinders of radius 10 in. whose axes meet at right angles. (Hint: In the figure above, show that every section one way is a square, whose area is  $400 - 4x^2$ .)

13. Water is poured from a cylindrical cup 8 in. tall and 8 in. in diameter. Find the volume remaining when the surface of the water just bisects the bottom of the cup.

14. Two cylinders have a common upper base, and tangent lower bases, — all circles of radius 10 in. Find the volume of the common solid, if the height between bases is 20 in. (See the figure, p. 146.)

15. By using the idea of the summation of tiny "elements," set up the integrals which express :

- (a) The momentum generated by a variable force ;  
 (b) The volume of a sphere of radius 10 in., regarded as composed of thin concentric shells at a varying distance  $r$  in. from the center.

[Hint: What are the area and thickness of any shell?]

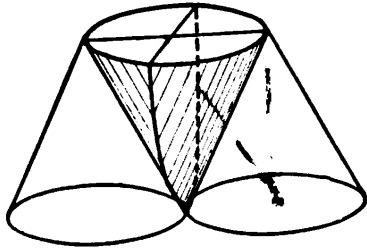

- (c) The area of a circle of radius 20 in., regarded as composed of narrow concentric rings, at a varying distance,  $r$  in. from the center.

- (d) The increase in the national wealth during any period if the rate of increase is some variable quantity  $R$ , — supposed known as a function of  $t$ .

[16.] Could the quantity  $(x^3+1)^{10} \cdot 3x^2$  be obtained by differentiating some power of  $(x^3+1)$ , possibly multiplied by a numerical factor? If so, find  $\int (x^3+1)^{10} 3x^2 dx$ .

§ 100. **Water Pressure: Total Force.** An important engineering problem is this: To calculate the total force with which water will press horizontally against a vertical wall or dam.

The pressure, that is to say, the number of pounds per sq. ft., is different at different depths: 1 ft. below the surface it is 62.5 lb. per sq. ft.; 2 ft. below, it is twice this; and so on, proportionally.

To find the total force against a dam, with the pressure varying all the way down, we may proceed in either of two ways.

(I) *By using the old conception of "tiny elements."*

According to this we may consider a very narrow strip across the dam as being all at one depth,  $x$  ft. below the surface of the water. The pressure against this strip is, then,

$$p = 62.5 x \text{ (lb. per sq. ft.)}.$$

The number of square feet in the strip is  $w dx$ , where  $w$  denotes the width of the dam at this depth. Multiplying the

number of pounds per sq. ft. by the number of square feet, we get the total force, or number of pounds, against the strip :

$$\text{Force against strip} = 62.5 x w dx \text{ (lb.)}$$

The total force against the dam is the sum of all these little forces :

$$F = \int 62.5 x w dx. \quad (19)$$

If we can get a formula for the width of the dam at any depth  $x$ , the total force can be found quickly by integrating (19).

If no such formula is obtainable for  $w$ , then  $F$  can merely be approximated by figuring out the force against many narrow strips, and adding.

(II) *By reasoning exactly about a "growing force."*

Let  $F$  denote the total force against the dam down to any depth  $x$ . Then while  $x$  increases by  $\Delta x$ ,  $F$  increases by some  $\Delta F$  (the force against the narrow strip in Fig. 49).

$$\Delta F = 62.5 \bar{x} \bar{w} \Delta x,$$

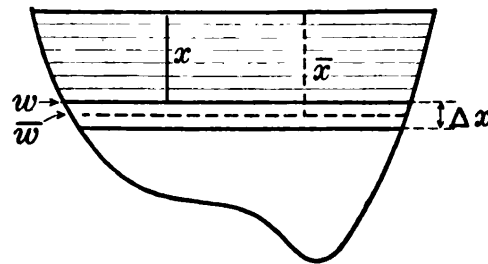

FIG. 49.

where  $\bar{x}$  and  $\bar{w}$  are some average depth and width in the strip.

The average rate of increase of  $F$ , per foot increase in  $x$ , is, then,

$$\frac{\Delta F}{\Delta x} = 62.5 \bar{x} \bar{w},$$

and the limit of this as  $\Delta x \rightarrow 0$  is

$$\frac{dF}{dx} = 62.5 x w,$$

whence we have (19) again, the  $\int$  denoting "integral of." \*

\* For oil instead of water, the only change in (19) would be a different numerical factor in place of 62.5. This is the weight of a cubic foot of water, and would be replaced by the weight of a cubic foot of the oil.

Ex. I. The width of a dam  $x$  ft. below the surface of the water is  $w = 400 - x^2$ . Find the total force against it down to a depth of 20 ft. Substituting in (19) the given value of  $w$  we have

$$F = \int 62.5 x(400 - x^2) dx = 62.5 \int (400x - x^3) dx.$$

$$\therefore F = 62.5(200x^2 - \frac{1}{4}x^4) + C.$$

But  $F = 0$  at the surface, where  $x = 0$ . Hence  $C = 0$ . And when  $x = 20$ , we have the whole force,  $F = 62.5(80000 - 40000)$ , = 2500000 (lb.).

§ 101. **Integrating a Power of a Quantity.** Can we ever integrate an expression which involves a product, or a power of a quantity, without first multiplying out? Yes, if the given expression happens to be the derivative of a higher power, — aside from a constant multiplier perhaps.

By (22), p. 111, we know that *differentiating* any power  $u^n$  gives  $nu^{n-1}du/dx$ . Hence if we are to integrate a given expression and come out with  $u^n$ , the expression must consist of a power of  $u$ , multiplied by the derivative of  $u$ , and possibly also by a constant.

Ex. I. Integrate  $(x^4 - 25)^9 4x^3 dx$ .

This is the 9th power of the quantity  $(x^4 - 25)$  times the derivative of that quantity. Hence it would result from differentiating the 10th power of that same quantity, — aside from a numerical factor  $1/10$ .

$$\therefore \int (x^4 - 25)^9 4x^3 dx = \frac{1}{10}(x^4 - 25)^{10} + C. \quad (20)$$

Observe that the factor  $4x^3$  is used up in integrating the power  $(x^4 - 25)^9$ . This will probably be clearer if you differentiate the result, and compare.

In the foregoing example, if we had been given  $7x^3$  instead of  $4x^3$ , the desired form  $4x^3$  could be found by taking the 7 outside, and multiplying and dividing by 4:

$$\int (\dots)^9 7x^3 dx = 7 \int (\dots)^9 x^3 dx = \frac{7}{4} \int (\dots)^9 4x^3 dx.$$

The result would have been  $7/4$  times the result in (20) above.

If, however, we had been given a *different power of  $x$* , say  $x^5$  instead of  $x^3$ , this could not be remedied by multiplying



and dividing, for a variable cannot be moved from one side of the integral sign to the other. [In fact, an  $x^5$  obviously would not arise in differentiating  $(x^4-25)^{10}$ .] We should have to multiply out before integrating.

Ex. II. Find  $y = \int \sqrt{9-x^2} x dx$ .

We need  $-2x$  outside the radical. So we change the form thus:

$$y = -\frac{1}{2} \int (9-x^2)^{\frac{1}{2}} \cdot -2x dx = -\frac{1}{2} \left[ \frac{2}{3} (9-x^2)^{\frac{3}{2}} \right] + C.$$

Ex. III. Find  $\int \sqrt{x^3+16} dx$ .

This is not yet possible, the factor  $x^2$  being absent outside the radical.

### EXERCISES

1. A gate of a canal "lock" has a constant width of 30 ft. and a height of 40 ft. When the water level is 10 ft. from its top, what is the total pressure against it? Calculate by integration, and also without.

2. The width of a certain dam at a depth of  $x$  ft. is  $w = 500 - x^2$ . Calculate  $w$  at  $x = 0, 2, 4, 6, 8, 10$ ; and make a rough drawing of the dam down to that depth. Estimate its area and the total force of water pressure against the part drawn.

3. Calculate the total force in Ex. 2 down to  $x = 10$ .

4. Find the total pressure down to a depth of 10 ft. if the width of a dam varies thus:  $w = 500 - 4x^2$ .

5. Find the total force against one face of a triangular board immersed in water, if one vertex is at the surface, one side (3 ft. long) is vertical, and the base (2 ft. long) is horizontal.

6. Find the following integrals and check each by differentiation:

(a)  $\int (16+x^4)^{\frac{3}{2}} 4x^3 dx$ ,

(b)  $\int \sqrt{9-x^2} 3x^2 dx$ ,

(c)  $\int \sqrt{25-x^2} x dx$ ,

(d)  $\int 9(x^5+9)^{-\frac{1}{2}} x^4 dx$ , ✓

(e)  $\int 7x^2(8-x^3)^{10} dx$ ,

(f)  $\int (x/\sqrt{x^2+1}) dx$ .

7. Find  $\int (x^2+3)^2 x dx$  in two ways, and reconcile the answers.

8. Find the total pressure on the end of a cylindrical boiler of radius 4 ft., placed horizontally, and half full of water. (Hint: The depth

$x$  and half-width  $w/2$  are sides of a right triangle whose hypotenuse is 4 ft. Integrate the final expression as in Ex. 6 c.)

9. The same as Ex. 8, if the radius is 5 ft.

10. Explain precisely what is meant by the "number of lb. per sq. ft. at the depth of  $x$  ft." We cannot have a square foot of vertical wall all at the same depth,  $x$  ft., no matter how narrow the strip.

11. A rectangular floor 30 ft. long and 20 ft. wide carries a load, whose amount per sq. ft. ( $y$  lb.) varies thus with the distance ( $x$  ft.) from one end:  $y=4x$ . Express the total load as an integral: (a) By using the old idea of elements; (b) By a consideration of rates.

§ 102. Further Applications. Many physical quantities calculated by integration are too complicated to discuss at present. One more case will be cited, however, viz.,

The total attraction of a uniform rod upon an exterior particle  $M$ , in its axis produced. By the law of gravitation:

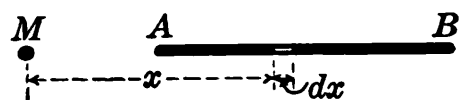

FIG. 50.

Every particle  $m$  of the rod attracts  $M$  with a force proportional to the product of the masses divided by the square of the distance apart:  $F=GMm/x^2$ , where  $G$  is a certain gravitational constant. But there are particles at all distances, within certain limits. (Fig. 50.)

Using the old conception, consider a tiny piece of the rod at any distance  $x$  from  $M$ . Its mass equals  $D$ , the mass per unit length, multiplied by  $dx$ , its length. The attraction of this tiny mass  $Ddx$  upon  $M$  is  $GMDdx/x^2$ . And the whole force is

$$F = \int \frac{GMDdx}{x^2}, = \frac{-GMD}{x} + C. \quad (21)$$

To check this, consider the growing attraction exerted by a varying portion of the rod, over to a distance  $x$  from  $M$ . Increasing  $x$  by  $\Delta x$  takes in additional force  $\Delta F$  which equals  $GMD\Delta x/\bar{x}^2$ ,  $\bar{x}$  denoting the average distance from  $M$  to points of the added portion  $\Delta x$ . Then  $\Delta F/\Delta x = GMD/x^2$ , and  $dF/dx = GMD/x^2$ . Hence we have (21) again, but with the sign  $\int$  used in its modern sense, to denote a quantity whose derivative is  $GMD/x^2$ .

§ 103. **Summary of Chapter IV.** Integration is the reverse of differentiation :

$$\int f(x)dx = F(x) \quad \text{means} \quad dF(x) = f(x)dx.$$

Its uses are of two sorts: (I) to derive a formula for some varying quantity whose rate of change is known, — *e.g.*, the height of a projectile at any time; and (II) to calculate some fixed geometrical or physical magnitude, such as area, work, etc.

But as each fixed area, etc., is the value to which some varying area, etc., will grow, problems of type (II) in reality come under type (I).

The constant of integration is determined by the value of  $x$ , or  $t$ , etc., at which the growing quantity starts.

In elementary geometry each new area and volume is calculated by some new plan. But by integration we find all volumes by one and the same process: Expressing the sectional area  $A$ , in terms of the distance  $x$  from some fixed point, and then integrating  $A, dx$ .\* Similarly all plane areas can be found by one process, all momenta by one process, etc. Moreover many problems which we have not yet analyzed yield to the same general method.

The science of calculating derivatives (or differentials) and integrals is known as *Differential and Integral Calculus*. It was invented by Sir Isaac Newton about 1670, and by Gottfried Leibnitz independently, a little later. Each made many notable calculations with his new invention — Newton's work in astronomy and physics being especially remarkable, although his notation was much less convenient than that of Leibnitz, which we are using.

In Differential Calculus the fundamental problem is to find the rate at which a given quantity is changing; in Integral Calculus it is the reverse: Given the rate, to find the value of the varying quantity.

Our work up to this point is, of course, barely a start in this field.

\* If no formula for  $A$ , is known, we can often find one by a preliminary integration. This will be discussed in Chapter XII.

## EXERCISES

1. Express and calculate the attraction in Fig. 50 if  $M = .08$ ,  $D = 2$ ,  $G = .000\ 000\ 065$ , the rod is 20 cm. long, and the particle 10 cm. away.

2. A rod 10 cm. long has a mass of .4 gram per cm. Find its total attraction on a particle of mass 5 grams, placed 6 cm. from the rod, and in line. Take  $G$  as in Ex. 1.

3. Find the total weight  $W$  of a rod 10 ft. long if its weight per ft. ( $w$  lb.) varies thus with the distance ( $x$  ft.) from one end:  $w = .1x$ . [Set up the integral in two ways.] *Can't be done. No such unit.*

4. Find the total load on a beam 15 ft. long if the rate of loading ( $y$  lb. per ft.) varies thus with the distance ( $x$  ft.) from one end:  $y = 20x$ . [Set up the integral in two ways.]

5. Like Ex. 11, p. 150, for a floor 40 ft. by 25 ft., if  $y$  varies thus:  $y = 10 + 2x$ .

6. Find the area under the curve  $y = 1/x^2$  from  $x = 2$  to  $x = 10$ .

7. The base of a solid is a circle of radius 10 inches, but every section perpendicular to one diameter is an isosceles triangle whose height equals half its base. Find the volume of the solid.

8. A triangular board is immersed vertically in water, its vertex being at the surface and its horizontal base being 6 ft. below. If the base is 8 ft. long, find the total force of water pressure against one face of the board.

9. A point moved in such a way that  $d^2y/dt^2 = 12$ ,  $y$  being the distance traveled. At  $t = 0$  the speed was 100 and the acceleration  $-6$ . Find  $y$  at any time.

10. Which of these forms can be integrated by some method already studied? (Do not work out.)

(a)  $x^2(x^4 + 8)^{\frac{1}{2}}dx$ ,

(b)  $x^3\sqrt{16 - x^4}dx$ ,

(c)  $(x^2 + 1)^{20}dx$ ,

(d)  $x(10 - x^2)^{30}dx$ .

11. A wedge 3 in. tall is cut off from a cylinder of radius 6 in. by a plane passing through a diameter of the base. Find its volume.

12. In stretching a spring, the force ( $F$  lb.) varied as the elongation ( $x$  in.) and was 50 lb. when  $x = 1$ . Find the work done in producing an elongation of 4 in., starting from normal length.

13. The force ( $F$  lb.) with which steam drove a piston varied thus:  $F = 12000/x^{\frac{4}{3}}$ . Find the work done from  $x = 8$  (in.) to  $x = 27$  (in.).

14. A bomb was thrown straight down from an airplane 8000 ft. high with an initial speed of 120 ft./sec. Derive a formula for its

height after  $t$  sec. How would you proceed to find the speed with which the bomb struck the ground?

15. A bomb was dropped from an airplane 2200 ft. high when an automobile running 80 ft./sec. passed directly beneath. How far apart were the bomb and automobile 10 sec. later, and how fast were they separating?

16. In Ex. 15 when were the bomb and automobile nearest?

17. A bomb was fired straight up from an airplane 10000 ft. high, with an initial speed of 400 ft./sec. Find its height after  $t$  sec. When did it strike the ground? When was it highest?

18. A beam loaded in a certain way has its curve defined by the equation  $d^4y/dx^4 = -.000036x$ . Find  $y$  as function of  $x$ , if at  $x=0$  we have  $y=0$ , slope =  $-.007$ , flexion = 0 and rate of increase of flexion =  $.0006$ .

19. Find the volume within the surface generated by revolving the curve  $y = x^2 - 4$  about its base line, from  $x=2$  to  $x=4$ .

[20.] Find by geometry the area of the smaller segment cut from a circle of radius 10 in. by a chord which subtends an angle of  $120^\circ$  at the center. Would it be more difficult to find the area if the central angle were  $100^\circ$  instead of  $120^\circ$ ?

§ 104. **Unknown Integrals.** We are not yet able to integrate some expressions which arise in simple problems.

Ex. I. Find the work done by a force which varies thus,

$$F = 3000/x,$$

from  $x=10$  to  $x=20$ .

$$W = \int F dx = 3000 \int \frac{1}{x} dx.$$

No integration formula has yet been given for  $\int x^{-1} dx$ .

(See § 88, p. 129.)

Ex. II. Find the area of the circular segment  $BCD$ . (Fig. 51.)

$$A = 2 \int y dx = 2 \int \sqrt{100 - x^2} dx.$$

We cannot effect the integration as yet. (Cf. Ex. III, § 101.)



On defining an instantaneous rate accurately as a *limit*, we saw that to calculate it we must find the limiting value approached by an average rate, whose interval is being indefinitely shortened. This brought us to differentiation, the chief operation of the Differential Calculus. We wrote derivatives of power functions at sight, and used them for various purposes.

Finally, we saw how to calculate various quantities by the Integral Calculus. But the usefulness of the integration process is limited at present by our inability to integrate many simple expressions; *e.g.*,

$$\sqrt{100-x^2}dx, \quad \frac{1}{x} dx.$$

Functions exist which have these differentials; but they are of different sorts than any which we have studied. So our next business will be to study some *further kinds of functions*, which incidentally are useful of themselves.

As suggested by the problem of the circular segment (§ 104) and that of the inclination of a curve (§ 85), we need to know the *relations between the sides and angles of a triangle*. To this matter we now turn our attention.

## CHAPTER V

### TRIGONOMETRIC FUNCTIONS

#### THE SOLUTION OF TRIANGLES

§ 106. **Some Preliminary Ideas.** The branch of mathematics which deals with the relations between the angles and sides of a triangle is called *Trigonometry*, — from two Greek words meaning “to measure a triangle.”

Trigonometry is the basis of all surveying, and of many calculations in engineering, physics, astronomy, and other sciences; — and yet it is perhaps the simplest of all the branches of mathematics.

Before proceeding with the subject proper, however, let us note certain very elementary methods of making approximations by drawing and measuring figures.

And, first, let us recall from geometry that an angle of any size can be measured or drawn by using a protractor.

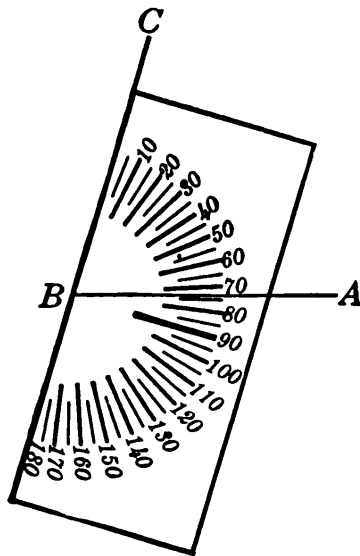

FIG. 52.

(I) Fig. 52 illustrates the measurement of a given angle  $ABC (= 73^\circ)$ . The radiating lines on the protractor should meet at the vertex  $B$  and the  $0^\circ$  line fall directly along  $BC$ . If  $AB$  tends to cross any radial line, the protractor is not placed correctly as to the vertex.

(II) In drawing an angle of  $73^\circ$ , we would first draw  $AB$  to serve as one side. Then, placing the protractor so that its  $73^\circ$  line falls directly over  $AB$ , we would draw  $BC$  along the  $0^\circ$  line of the protractor. (In



allowing for the width of the pencil point, the protractor is slid along in such a way as to keep its  $73^\circ$  line *pointing directly along AB, continually.*)

§ 107. **Graphical Solution of Triangles.** Any ordinary surveying problem can be solved approximately by simply *drawing the figure to some chosen scale, and reading off the required distances or angles.*

With good instruments and practice the percentage of error can be kept very low. Thus we can check roughly the more refined methods developed presently, which use trigonometry proper.

Ex. I. Find the distance  $AB$  across a pond (Fig. 53), if the distances  $CA$  and  $CB$  and  $\angle C$  have been measured as 900 ft., 700 ft., and  $35^\circ$ .\*

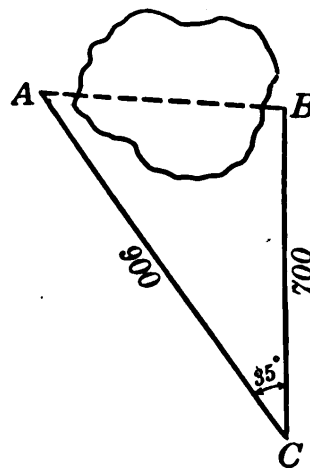

FIG. 53.

We draw an angle of  $35^\circ$ , with a protractor, and lay off sides of 9 cm. and 7 cm., to represent  $CA$  ( $=900$  ft.) and  $CB$  ( $=700$  ft.), respectively. Joining the ends of these lines we get a triangle which must be similar to the actual big triangle  $ABC$ . (Why?) The third side of the constructed triangle measures 5.4 cm.; hence the distance  $AB$  is 540 ft.

§ 108. **Force Problems.** If two forces, acting in the directions  $OA$  and  $OB$  (Fig. 54), are simultaneously applied

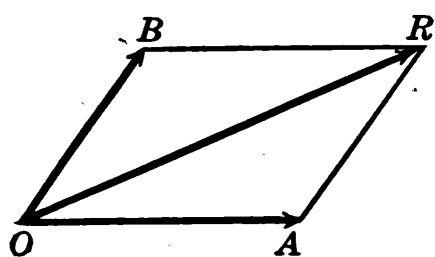

FIG. 54.

to an object at  $O$ , the object will move neither along  $OA$  nor along  $OB$ , but in some intermediate direction. More definitely, the principle is this:

(I) *If two forces are represented, in intensity and direction, by two sides of a parallelogram  $OA$  and  $OB$ , drawn from a common vertex, they are together equivalent to a single force*

\* The angle is measured by placing a surveyor's transit at  $C$ , sighting at  $A$ , and then at  $B$ , and reading from the instrument the angle turned.

represented on the same scale by the diagonal of the parallelogram  $OR$  drawn from that vertex.

The resulting motion would be along that diagonal. The single force represented by the diagonal is called the **resultant** of the two given forces.

To find the resultant of two given forces: simply draw the forces on some chosen scale, as in Fig. 54, complete the parallelogram, and read off the force represented by the diagonal. The *direction* of the resultant can be ascertained by measuring the angle which it makes with one of the given forces.

To find what third force would balance any two given forces and maintain equilibrium: observe that the given forces are together equivalent to a single force, — their resultant. Hence the third force must be equal to the resultant in intensity, but oppositely directed. Thus it is easily drawn and measured. In general:

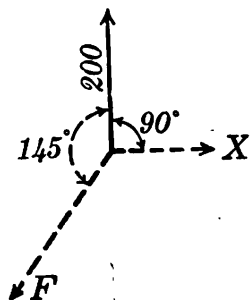

(II) *If three forces are in equilibrium, any one of them must equal the resultant of the other two, but with its direction reversed.*

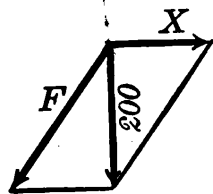

FIG. 55.

Ex. I. Find the two forces  $X$  and  $F$  in Fig. 55, which are just balanced by the upward force of 200 lb.

The resultant of  $F$  and  $X$  must be a force of 200 lb. directed straight downward. Knowing the diagonal of the parallelogram and the directions

of the sides, we easily construct the parallelogram, and read off the intensities of  $F$  and  $X$ .

### EXERCISES

1. Draw any triangle, measure its three angles, and check their sum by geometry. Repeat for another triangle.
2. Draw a triangle with one side 10 cm. long, and with the adjacent angles  $40^\circ$  and  $80^\circ$ . Measure the third angle and check.

3. Draw a parallelogram whose angles are  $72^\circ$  and  $108^\circ$ . Measure opposite sides as a check.

4. To find the distance  $AB$  through a hill, lines  $AC = 748$  ft., and  $BC = 680$  ft., were measured, also  $\angle C = 50^\circ$ . Find  $AB$ .

5. To find the distance between two points  $A$  and  $B$ , both across a river, a line  $CD = 1000$  ft. was laid off on this side, and angles were measured as follows:  $\angle CDB = 75^\circ$ ,  $\angle CDA = 40^\circ$ ,  $\angle DCB = 45^\circ$ ,  $\angle DCA = 75^\circ$ . Find  $AB$ .

6. Find the resultant  $R$  for two forces,  $X = 150$  lb. and  $Y = 90$  lb., whose included angle is  $60^\circ$ . Also find the angle which  $R$  makes with  $X$ .

7. The same as Ex. 6, but with  $X = 800$  lb.,  $Y = 500$  lb., and their included angle  $120^\circ$ .

8. A horizontal force  $OH = 160$  lb. and a vertical force  $OV = 120$  lb. are balanced by a single force  $F$ . Find the intensity and inclination of  $F$ .

9. The same as Ex. 8, but with  $OH = 330$  lb. and  $OV = 440$  lb.

10. Find the forces  $X$  and  $F$  in Fig. 55, after changing the angle from  $145^\circ$  to  $115^\circ$ .

11. A 200 lb. weight at the end of a rope swings around in a horizontal circle, the rope making an angle of  $30^\circ$  with the vertical, as in the figure above. What must be the centrifugal force,  $X$  lb., and the pull in the rope,  $P$  lb.?

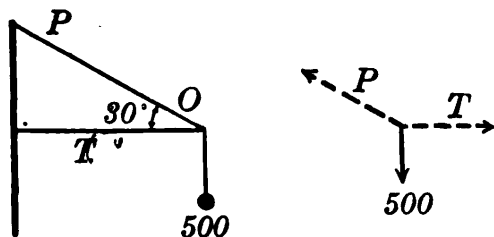
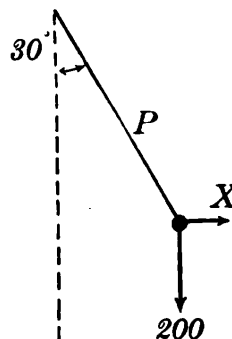

12. Find the pull ( $P$  lb.) in the cable, and the horizontal thrust ( $T$  lb.) exerted by the arm of the adjacent crane at  $O$  to support the weight of 500 lb.

13. The same as Ex. 12, but with the given angle  $35^\circ$  and the weight 7500 lb.

14. Fig. 65, p. 171, shows a corner of a bridge-structure. What forces,  $F$  and  $X$ , acting along the members meeting at  $O$  would just be balanced by the vertical force of 200 tons? (Hint: Draw all forces away from  $O$  in their proper directions.)

15. The same as Ex. 14, but with the given angle  $30^\circ$  and the force 90,000 lb.

[16.] At several points on one side of an acute angle, erect perpendiculars, and measure the sides of each right triangle so formed. Divide the side opposite the given angle by the hypotenuse in each case, and compare. Likewise the opposite side by the adjacent side.

§ 109. **The Functions Sin A and Tan A.** If we erect perpendiculars at various points of either side of any acute angle (Fig. 56), the right triangles thus formed are all similar. (Why?) Hence their corresponding sides are proportional. *E.g.*,

$$\frac{a}{b} = \frac{a'}{b'} = \frac{a''}{b''}, \text{ etc.}$$

Thus the ratio  $a/b$  does not depend at all upon the size of the triangle. But if we change the size of angle  $A$ , the triangle changes shape, and  $a/b$  no longer has the same value. In fact,  $a/b$  varies with  $\angle A$  in some definite way, and is therefore some function of  $A$ .

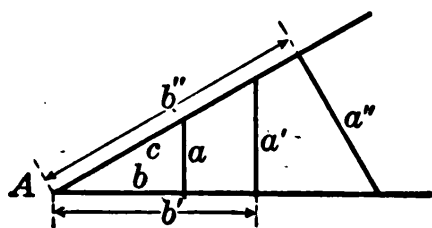

FIG. 56.

Likewise  $a/c$ ,  $b/c$ , etc., are functions of  $A$ . All of these are called

*trigonometric functions*, and each has a name of its own.

The ratios  $a/c$  and  $a/b$  are called respectively the “sine” and “tangent” of  $\angle A$ , written  $\sin A$  and  $\tan A$ . That is, *if a perpendicular is erected at any point in either side of an acute angle A, forming a right triangle, then*

$$\sin A = \frac{\text{leg opposite } \angle A}{\text{hypotenuse}} = \frac{a}{c}. \quad (1)$$

$$\tan A = \frac{\text{leg opposite } \angle A}{\text{leg adjacent to } \angle A} = \frac{a}{b}. \quad (2)$$

(Memorize these definitions carefully. Also observe that the hypotenuse does not appear in  $\tan A$  at all.\*)

The values of these ratios are given for various angles, correct to three places, in the table on p. 161. For instance,  $\sin 20^\circ = .342$ . This means that in any right triangle containing an angle of  $20^\circ$ , the opposite leg divided by the hypotenuse gives .342, no matter how large or small the triangle may be. (How could we check this roughly?)

\* The reason for the name “tangent” appears in Ex. 27, p. 166; “sine” is derived from a Hindu word.

SINES AND TANGENTS OF ACUTE ANGLES \*

Ang	Sin	Tan	Ang	Sin	Tan	Ang	Sin	Tan
1°	.017	.017	31°	.515	.601	61°	.875	1.80
2	.035	.035	32	.530	.625	62	.883	1.88
3	.052	.052	33	.545	.649	63	.891	1.96
4	.070	.070	34	.559	.675	64	.899	2.05
5	.087	.087	35	.574	.700	65	.906	2.14
6	.105	.105	36	.588	.727	66	.914	2.25
7	.122	.123	37	.602	.754	67	.921	2.36
8	.139	.141	38	.616	.781	68	.927	2.48
9	.156	.158	39	.629	.810	69	.934	2.61
10	.174	.176	40	.643	.839	70	.940	2.75
11	.191	.194	41	.656	.869	71	.946	2.90
12	.208	.213	42	.669	.900	72	.951	3.08
13	.225	.231	43	.682	.933	73	.956	3.27
14	.242	.249	44	.695	.966	74	.961	3.49
15	.259	.268	45	.707	1.00	75	.966	3.73
16	.276	.287	46	.719	1.04	76	.970	4.01
17	.292	.306	47	.731	1.07	77	.974	4.33
18	.309	.325	48	.743	1.11	78	.978	4.70
19	.326	.344	49	.755	1.15	79	.982	5.14
20	.342	.364	50	.766	1.19	80	.985	5.67
21	.358	.384	51	.777	1.23	81	.988	6.31
22	.375	.404	52	.788	1.28	82	.990	7.12
23	.391	.424	53	.799	1.33	83	.993	8.14
24	.407	.445	54	.809	1.38	84	.995	9.51
25	.423	.466	55	.819	1.43	85	.996	11.43
26	.438	.488	56	.829	1.48	86	.998	14.30
27	.454	.510	57	.839	1.54	87	.999	19.08
28	.469	.532	58	.848	1.60	88	.999	28.64
29	.485	.554	59	.857	1.66	89	1.00—	57.29
30	.500	.577	60	.866	1.73			
	<del>Cos</del>	Ctn		Cos	Ctn		Cos	Ctn

§ 110. **Solution of Right Triangles.** Finding the unknown sides or angles of a definitely specified triangle is called "solving the triangle." This can be done roughly by

\* The bottom labels are for later use.

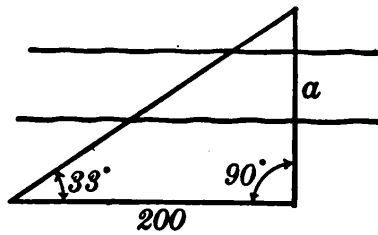

FIG. 57.

measuring a drawing, — as we have seen. For more accurate results we calculate the unknown parts of the triangle from given parts, making use of the definition of the sine or tangent, and consulting the table on p. 161, or some

larger table. The following examples will illustrate this.

Ex. I. Find by tables the side  $a$  of the triangle in Fig. 57.

$$\tan 33^\circ = \frac{a}{200}.$$

But  $\tan 33^\circ = .649$  (by table).

$$\therefore \frac{a}{200} = .649 \quad \therefore a = 130 \text{ (nearly).}$$

This result can be checked graphically.

Ex. II. Find the two forces  $X$  and  $Y$  in Fig. 58, which are together equivalent to the given force of 400 lb.

$X$  is represented by the side opposite the  $25^\circ$  angle, while  $Y$  is opposite the complementary angle of  $65^\circ$ .

$$\frac{X}{400} = \sin 25^\circ = .423, \quad \therefore X = 169^+,$$

$$\frac{Y}{400} = \sin 65^\circ = .906, \quad \therefore Y = 362^+.$$

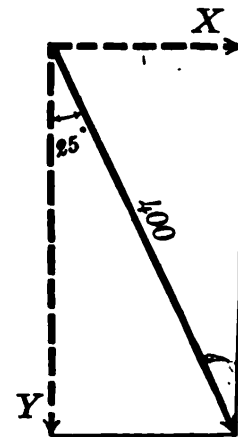

FIG. 58.

*N.B.* We could get  $Y$  here after having found  $X$ , by using the tangent. But any error in  $X$  would render  $Y$  incorrect also. It is best, whenever convenient, to find each required part of a triangle from given parts. To do this, simply choose whichever function (sine or tangent) will bring in the unknown part, together with other parts which are all given. When possible, get the unknown in the numerator, and thus avoid division.

Ex. III. Given the hypotenuse of a right triangle,  $c=615$ , and one leg,  $a=369$ , to find the angles and the other leg. (Fig. 60, p. 169.)

$$\sin A = \frac{a}{c} = \frac{369}{615} = .600,$$

whence  $A = 37^\circ$  by the table; and  $B = 90^\circ - A = 53^\circ$ . Also

$$b = \sqrt{(615)^2 - (369)^2} = 492, \text{ approx.}$$

Or, since  $b$  is opposite  $\angle B$ , we could get it by using

$$\frac{b}{615} = \sin B = .799, \text{ whence } b = 491, \text{ approx.}$$

The preceding method is better if a large table of squares is available.

Since the table is accurate to three places only, so are the results. Significant figures beyond the third should be dropped, and the nearest figure in the third place taken.

The placing of a decimal point should always be checked by common sense. Thus  $615 \times .799$  above clearly could not give 4915 nor 49.15, as it must give a little less than 615.

*Remark.* At first thought there may not seem to be any connection between this work of solving triangles and our main problem of studying how one quantity varies with another. But the solution of triangles is possible only because the sine and tangent vary with the angle in a definite way, — studied by mathematicians in the past and recorded in the tables.

### § 111. Slope and Inclination.

One of the most important uses of the tangent function is in finding the inclination (angle) of a line whose slope is known, or *vice versa*.

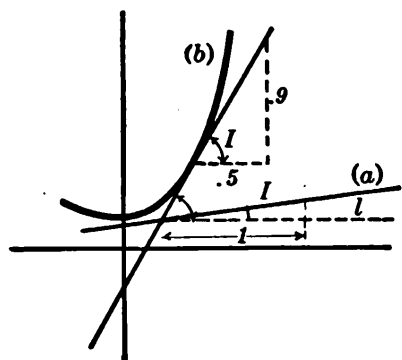

FIG. 59.

Since the slope  $l$  is the number of units the line rises in one horizontal unit (Fig. 59), we evidently have  $\tan I = l/1$ , or

$$l = \tan I. \quad (3)$$

For instance, if a hillside has an inclination of  $15^\circ$ , its slope is  $l = \tan 15^\circ = .268$ . In other words, its grade is 26.8%.

Again, if a ship's deck has a slope of  $\frac{1}{12}$ , its inclination is given by

$$\tan I = \frac{1}{12} = .083, \quad \therefore I = 5^\circ, \text{ nearly.}$$

The slope of a *curve*, or of its *tangent line*, at any point is easily found by differentiation:  $l = dy/dx$ . The inclination can then be found by using formula (3).<sup>\*</sup> Thus, in Fig. 59, *b*,

$$\tan I = \frac{.9}{.5} = 1.800. \quad \therefore I = 61^\circ.$$

The angle between two lines or curves in the same vertical plane can be found by subtracting the inclination of the one from that of the other.

*Definition.* When an object is viewed from any point, the inclination of the line of sight is called the *angle of elevation*, or *angle of depression*, of the object. Literally, it is the amount we must elevate, or depress, our gaze from horizontal to see the object.

### EXERCISES

1. Draw a right triangle containing an angle of  $40^\circ$ , and verify by measurement the values of  $\sin 40^\circ$  and  $\tan 40^\circ$  given in the table, p. 161.
2. Draw a right triangle whose legs are 9 and 4. Measure the angle whose tangent is  $\frac{3}{4}$ , and check by the table.
3. Write out the values of the sine and tangent for each acute angle in these right triangles.

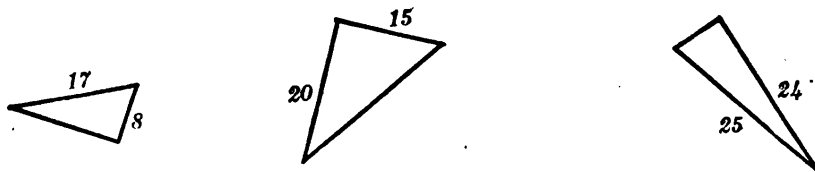

<sup>\*</sup> If  $l$  happens to be negative, we change its sign to  $+$  before using formula (3). But we must remember that the line is *falling* at the angle  $I$  rather than *rising*.



4. Given  $\tan A = \frac{5}{12}$ , find  $\sin A$  exactly (without tables). Likewise find  $\tan B$  exactly if given  $\sin B = \frac{1}{2}$ .

*In Ex. 5-14, first solve by drawing to scale and measuring the required part. Then solve by the table, directly from the given parts, without using your measurements. Compare results.*

5. Find the slope and the inclination of a hillside which rises uniformly 238 ft. in a horizontal distance of  $\frac{1}{2}$  mile.

6. Find the extreme height of Philadelphia City Hall if the angle of elevation, measured at a point 990 ft. from the base of the building on a level street, is  $29^\circ$ .

7. The Pike's Peak Ry. rises 7800 ft. in a distance of  $9\frac{1}{2}$  mi. along the track. At what angle would the track have to ascend if the inclination were uniform?

8. In Ex. 11, p. 159, change the weight to 175 lb. and the angle to  $20^\circ$ , and solve.

9. When light passes from one medium into another, the angles of incidence and refraction ( $I$  and  $R$ ) are related thus:  $\sin R = k \sin I$ . If  $k = \frac{3}{4}$  and  $I = 30^\circ$ , find  $R$ .

10. How far would a swimmer be from the Statue of Liberty, if its top (301 ft. above the water) had an elevation angle of  $12^\circ$ ?

11. A boulevard runs in a direction  $30^\circ$  north of east. How far east does it go to reach a street which is .8 mi. north of its starting point?

12. Mt. Hood is 51 mi. from Portland, Ore., in a direction  $14^\circ$  south of east. How far south is it, and how far east, from the city?

13. What direction is Mt. St. Helens from Portland, if 47 mi. north and 24.5 mi. east?

14. (a) Find the slopes of lines whose inclinations are  $3^\circ$ ,  $20^\circ$ ,  $45^\circ$ ,  $78^\circ$ ,  $85^\circ$ . Express each slope also as a "grade."

(b) Find the inclination of a line if the slope is  $\frac{1}{2}$ ,  $\frac{3}{4}$ , 4; also if the grade is 6%, 20%, 180%.

15. On the Mt. Lowe (cable) railway the steepest grade is 67%. What is the inclination at that point?

16. A ship's deck rises 1 inch in 1 ft. horizontally. What is its inclination? What if the deck rises 2 in. in 27 in. horizontally?

17. Plot  $y = x^2$  from  $x = 0$  to  $x = 3$ . Measure the inclination of the tangent line at  $x = 2$ . Calculate the same without using the figure; and check.

18. At what angle will a line whose slope is  $\frac{1}{2}$  cross one whose slope is .3?

*Note : In the following exercises, the short-cuts given in the Appendix, p. 491, would be useful.*

19. In Fig. 65, p. 171, change the angle to  $60^\circ$  and the given force to 12500 lb., and solve.

20. The rafters of a roof are inclined  $40^\circ$ . Find the height of the ridge above the eaves if the distance between eaves is 25 ft.

21. Find the area of the segment cut off from a circle of radius 125 cm. by a chord whose length is 190 cm.

22. The hypotenuse and one leg of a right triangle are respectively 104 in. and 96 in. Find the other leg and the angles.

23. Using the tabulated values at  $5^\circ$ ,  $10^\circ$ , etc., up to  $85^\circ$ , plot a graph showing how  $\tan A$  varies with  $A$ . Does the tangent double when the angle doubles?

24. Same as Ex. 23 for  $\sin A$ .

25. In Fig. 58 change the given force to 650 lb. and the given angle to  $37^\circ$  and solve for  $X$  and  $Y$ .

26. A circular filter paper, when folded for use, makes a circular cone whose circumference is half the original circumference, and whose slant height equals the original radius. What is the vertex angle of the cone?

27. Draw an angle of  $40^\circ$  at the center of a circle whose radius is 1 unit. Where one side of the angle cuts the circle, draw a tangent, prolonging it to meet the other side. How long is this tangent line? This shows the origin of the name "tan A."

28. The eye sees colors incorrectly at certain angles from the center of the field of vision, — different for different persons. In one experiment red appeared as yellow when 14.3 cm. ahead and 8.5 cm. to the right, and appeared as black when 15 cm. to the right. Find the angle from the central line of vision in each case.

29. A ship is sailing  $20^\circ$  north of east at the rate of 14 mi./hr. How fast is it going northward and how fast eastward?

30. A man, running at the rate of 9 ft./sec. in a shower of rain falling vertically, holds his umbrella  $20^\circ$  from vertical for the best protection. How fast is the rain falling?

31. In just what direction should a gun be aimed to fire at invisible targets which are known to be : (a) 4 mi. north, 2.5 mi. east ; (b) 1200 yd. N., 3000 yd. E.?

32. How far from the gun is each target in Ex. 31?

33. Seen from an airplane 15000 ft. high a town has a depression angle of  $32^\circ$ . How far away is it, horizontally?

§ 112. **Cosine and Cotangent.** The ratio  $b/c$  (Fig. 60) is called the “cosine” of angle  $A$ , written  $\cos A$ . Also  $b/a$  is called the “cotangent,” written  $\text{ctn } A$ . That is,

$$\cos A = \frac{\text{adjacent leg}}{\text{hypotenuse}} = \frac{b}{c}; \tag{4}$$

$$\text{ctn } A = \frac{\text{adjacent leg}}{\text{opposite leg}} = \frac{b}{a}.$$

The ratio  $b/c$  is also the sine of  $\angle B$ . That is, the cosine of any angle is the sine of the complementary angle. Thus  $\cos 20^\circ = \sin 70^\circ$ ;  $\cos 50^\circ = \sin 40^\circ$ , etc.

The name “cosine” is simply a contraction of “complement’s sine.” Similarly the cotangent is the “complement’s tangent.”

Notice also that  $\text{ctn } A$  is the reciprocal of  $\tan A$  (i.e.,  $1/\tan A$ ); but  $\cos A$  is not the reciprocal of  $\sin A$ .

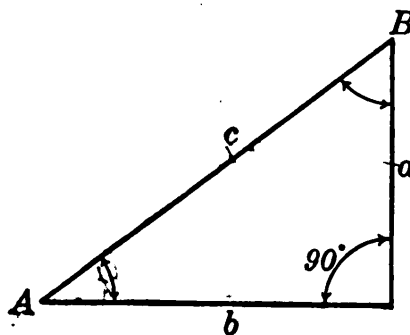

FIG. 60.

Evidently a table of sines is also a table of cosines for the complements of the angles listed. This fact is indicated by the label *cos* at the bottom of each sine column, p. 161.\*

By using  $\cos A$  and  $\text{ctn } A$  we can solve some right triangles more directly, and avoid introducing the second acute angle.

To fix the definitions of the four functions in mind, try repeating them a few times:

$$\text{sine} = (\text{opposite leg}) \div (\text{hypotenuse}); \text{ etc.}$$

Then take a group of right triangles turned in various positions, and practice picking off the functions as in Ex. 1 below. Do this frequently at odd moments. *It is exceedingly important to fix the definitions permanently in mind, and to do so now.*

\* For convenience in looking up cosines and cotangents, you had best write in, at the right of each group of columns, the angles complementary to those printed on the left. (Every  $5^\circ$  or so will do.) This will call attention, for example, to the fact that the value .643 labeled  $\sin 40^\circ$  is also  $\cos 50^\circ$ .

## EXERCISES

1. In Ex. 3, p. 163, read off the cosine and cotangent of each acute angle.
2. Find the leg adjacent to an angle of  $23^\circ$  in a right triangle: (a) if the opposite leg is 400 ft., (b) if the hypotenuse is 1000 ft.
3. Find an angle of a right triangle: (a) if the adjacent leg is 43 and the hypotenuse is 50; (b) if the adjacent leg is 273.6 and the opposite leg is 300.
4. Given  $\cos A = \frac{3}{5}$ , find  $\sin A$ ,  $\tan A$ ,  $\cot A$  exactly, without tables.
5. Similarly, find  $\sin A$ ,  $\cos A$ ,  $\cot A$ , if given  $\tan A = \frac{3}{4}$ .
6. Interpolate in the table to find  $\cos 22^\circ 24'$  and  $\cot 22^\circ 24'$ .
7. A battleship 594 feet long, turned broadside toward us, subtends an angle of  $4^\circ$ . How far away is it?
8. In Fig. 63, p. 169, let  $F$  be 2500 and  $\angle A = 26^\circ$ . Solve for  $X$  and  $Y$ .
9. Find the perimeter and area of a regular decagon inscribed in a circle of radius 19.98 inches.
10. Find the radius of the "Arctic circle," taking the earth's radius as 3960 mi. (Latitude  $66^\circ 30'$ .)
11. Find similarly the radius of the "Tropic of Cancer."
12. Bisect one angle of an equilateral triangle whose sides are 10 in., and calculate from either right triangle so formed the sine, cosine, and tangent for  $30^\circ$  and  $60^\circ$ . Compare the table.
13. Calculate geometrically the functions of  $45^\circ$ . Compare the table.
14. If the hypotenuse of a right triangle is  $c$ , and one acute angle is  $A$ , what are the values of the two legs  $a$  and  $b$ ? Using this result, draw several triangles with various angles and hypotenuses and write at sight expressions for the legs of each.

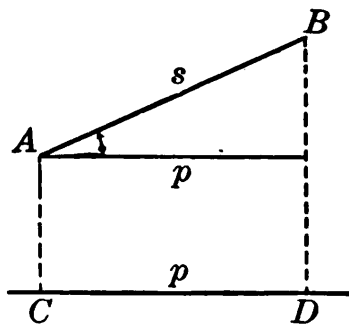

FIG. 61.

15. Find the volume of water in a horizontal cylindrical boiler of radius 28 in. and length 5 ft. when the water is 10 in. deep in the middle.

§ 113. **Projections.** We shall frequently need to consider the *projection* of a given line-segment  $s$  upon some other line  $l$ , — *i.e.*, the distance  $p$  between perpendiculars dropped from the ends of  $s$  upon  $l$ . (Fig. 61.) Much time will be saved by getting a formula for the value of such a projection in any case.

Now  $p/s = \cos A$ , and therefore,

$$p = s \cos A. \tag{5}$$

That is, *the projection equals the segment itself, multiplied by the cosine of the included angle.*

The same principle holds good for the projection of any plane area upon another plane.

For suppose  $BQFB$  (Fig. 62) is the projection of any area  $BPFB$ , determined by dropping perpendiculars from all points of the bounding curve  $BPF$ . Then, regarding each of the areas as the area under a curve whose height above the base-line at any point is  $y$  or  $Y$ , respectively, the projection and the original area are given by the integrals:

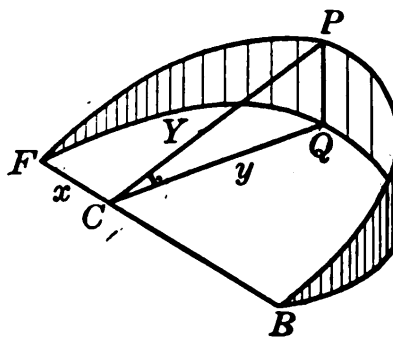

FIG. 62.

$$P = \int y dx, \quad A = \int Y dx.$$

But  $y = Y \cos C$  by (5) above. Substituting this in the first integral:

$$P = \int (Y \cos C) dx = \cos C \cdot \int Y dx = \cos C \cdot A. \tag{6}$$

That is, *the projection equals the original area multiplied by the cosine of the angle between the two planes.*

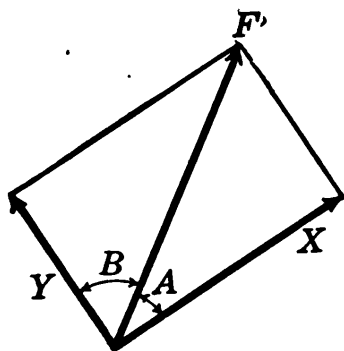

FIG. 63.

Observe that the projection of a line or area is always located at the feet of the perpendiculars, and is smaller than the original line or area.

**§ 114. Components.** Any two forces  $X$  and  $Y$ , which would together be equivalent to a single force  $F$ , are called *components* of  $F$ . If mutually perpendicular, — which is the way

components are taken unless otherwise stated, — they are easily found.

$$X = F \cos A, \quad Y = F \cos B. \quad (7)$$

Thus, *the component of a force in any direction is equal to the force itself, multiplied by the cosine of the included angle.*

The value of  $Y$  in (7) is the same as  $Y = F \sin A$ . (Why?)

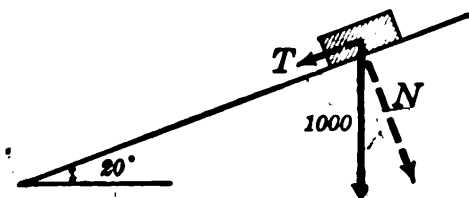

FIG. 64.

Ex. I. Find the two components  $N$  and  $T$  of the weight of the block in Fig. 64, if the plane is inclined  $20^\circ$ .

The angles at the block are  $20^\circ$  and  $70^\circ$ . Hence

$$N = 1000 \cos 20^\circ = 940,$$

$$T = 1000 \cos 70^\circ = 342.$$

That is, the force with which the block presses against the plane is 940 lb., and the force tending to move the block down along the plane is 342 lb. If there were no friction, a pull of 342 lb. up the plane would just keep the block from sliding.

### EXERCISES

1. Find the horizontal and vertical projections of a line 9.8 ft. long inclined  $20^\circ$ .
2. What will be the apparent shortest diameter of a wheel of radius 19.8 inches if its axle makes an angle of  $40^\circ$  with the line of sight?
3. The same as Ex. 2, for a diameter of 25 in. and an angle of  $76^\circ$ .
4. What area in a pipe of radius 10 inches would be obstructed by a damper turned  $70^\circ$  from the position of complete obstruction?
5. What fractional part of the area would be obstructed in any pipe with the damper turned  $45^\circ$ ?
6. An erect cylinder of radius 5 in. is cut by a plane inclined  $50^\circ$ . What are the area and the longest diameter of the sloping section?
7. Find the volume cut from a circular cylinder of radius 10 in. by a plane through a diameter of the base inclined  $40^\circ$ .
8. In Ex. 7, find also the area of the sloping plane section.
9. In Fig. 64 change the angle to  $18^\circ$  and the weight of the block to 997 lb. and solve for the components  $T$  and  $N$ .
10. Find the horizontal and vertical components of a force of 1250 lb. inclined  $33^\circ$ .

11. A weight is suspended by two wires, each inclined  $22^\circ$ . If the greatest straight pull which either wire could sustain is 450 lb., how large a weight could the two support as specified?

12. If a ship is sailing  $21^\circ$  north of east at the rate of 15 mi. per hour, what are its component speeds, northward and eastward?

13. Similar to Ex. 12, but sailing 17.3 mi./hr.  $66^\circ$  south of west.

14. If a wind is blowing 17.5 ft./sec. and crosses the direction of artillery fire at an angle of  $38^\circ$ , what are its component velocities along, and directly across, the direction of fire?

15. Same as Ex. 14, if the wind velocity is 9.8 m./s., crossing at an angle of  $72^\circ$ .

16. A force  $F$  lb. inclined  $23^\circ$  has a horizontal component of 873 lb. Find  $F$ .

17. A sled is pulled on a level road by a cable inclined  $18^\circ$ . If the pull in the cable is 200 lb. how much work is done in pulling the sled 500 ft.? (Hint: Only the horizontal component does any work.)

18. How large a board held perpendicular to the sun's rays would shade 1 sq. ft. of level ground when the sun is  $60^\circ$  above the horizon?  $20^\circ$  above? (What connection has this with the cause of the seasons?)

§ 115. **Equilibrium of Forces: Component Method.** The unknown forces needed to balance a given force, or forces, can be found without drawing a force triangle or polygon.

To illustrate, let us find the forces  $F$  and  $X$  acting along the two members of a bridge-structure (shown in Fig. 65) if the supporting force exerted by the pier is 200 tons.

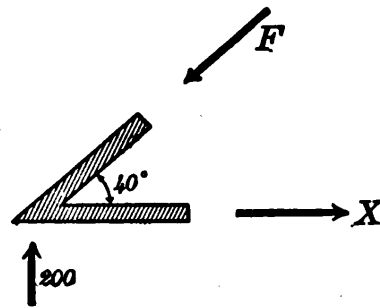

FIG. 65.

We first tabulate the horizontal and vertical components of all the forces:

FORCE	HORIZ.	VERT.
$F$	$F \cos 40^\circ$	$F \cos 50^\circ$
$X$	$X$	0
200	0	200

(Clearly the 200 ton force can have no effect horizontally, nor  $X$  have any vertically.)

The component of a force along any direction measures its tendency to produce motion in that direction. Hence, *the vertical components must balance one another.*

$$F \cos 50^\circ = 200, \quad \therefore F = \frac{200}{\cos 50^\circ} = 311.$$

Similarly, the horizontal components must balance:

$$F \cos 40^\circ = X, \quad \therefore X = 238.$$

In like manner, — as is shown in treatises on Statics, — it is possible to go on to the other joints of a structure and find the forces acting at each. Thus the forces along all the members can be found if the supporting forces exerted by the piers are known. The principle by which those forces are found is a very familiar one.

**§ 116. Moment of a Force.** As every one knows, a 50-lb. boy can balance a 100-lb. boy on a “teeter” board by sitting

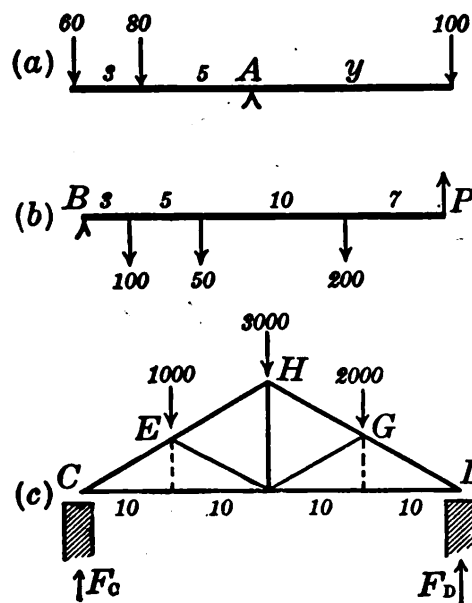

FIG. 66.

just twice as far from the supporting rail or fulcrum. This is because the “moment” of each weight (*i.e.*, its tendency to produce rotation about the point of support) is proportional to its distance from that point.

*General Principle:* The moment of any force about any point equals the product of the force by its arm, — that is, by the perpendicular distance from the point to the line of action of the force.



Thus, in Fig. 66 (a), we have about the point  $A$  :

<i>Force</i>	<i>Arm</i>	<i>Moment</i>
80 lb.	5 ft.	400 lb.-ft.
60 "	8 "	480 "
100 "	$y$ "	$100 y$ "

The first two forces tend to turn the beam about  $A$  in one direction; and the third in the opposite direction. If the latter is just to balance the other two, *its moment must equal the sum of their moments* :

$$\therefore 100 y = 880. \qquad \therefore y = 8.8.$$

Likewise in Fig. 66 (b), if the force  $P$  is just large enough to prevent the other forces from rotating the beam about  $B$ , its moment must balance theirs :

$$P(25) = 100(3) + 50(8) + 200(18). \quad \therefore P = 172.$$

And again, in Fig. 66 (c), if the force  $F_D$  is to prevent rotation about  $C$ ,

$$F_D(40) = 1000(10) + 3000(20) + 2000(30). \quad \therefore F_D = 3250.$$

Similarly, to prevent rotation about  $D$

$$F_C(40) = 1000(30) + 3000(20) + 2000(10). \quad \therefore F_C = 2750.$$

*Check* :  $F_C + F_D$  equals the sum of the three loads,  $1000 + 3000 + 2000$ .

### EXERCISES

1. A beam 30 ft. long weighing 10 lb. per ft. rests on a post at one end  $A$  and is supported by a vertical cable at the other end  $B$ . It carries a load of 500 lb. 12 ft. from  $A$ . Find the pull in the cable.

(Hint: Regard the weight of the beam as a single force acting at its center.)

2. The same as Ex. 1 but with an additional load of 200 lb. 8 ft. from  $B$ .

3. In Fig. 66 (c), what forces are exerted by the piers if the loads are 8000 lb., 15000 lb., and 12000 lb. at distances of 10 ft., 20 ft., and 30 ft. from one pier?

4. The same as Ex. 3, if the three loads are 1000 lb., 1000 lb., and 3000 lb.

5. The two piers at the ends of a bridge beam carry loads of 15000 lb. and 18000 lb. respectively, due to the weight of the bridge. If a car

weighing 4000 lb. stands on the bridge one fourth way from the first pier, what load will the other pier then carry?

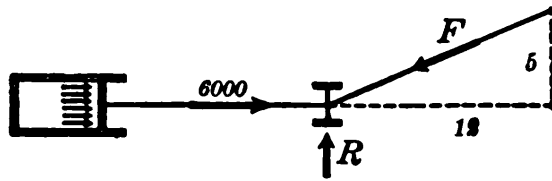

FIG. 67.

6. Solve Ex. 12, p. 159, by the component method, changing the given angle to  $50^\circ$ .

7. In Ex. 11, p. 171, what is the pull in each wire if the supported weight is 100 lb.?

8. The reaction  $R$  of the guide is vertical in Fig. 67. Find the force  $F$ .

9. In Fig. 65, change the supporting force to 25000 lb., the angle to  $35^\circ$ , and find  $F$  and  $X$  by considering components.

10. In Fig. 66 (B), add 50 lb. to each force and find  $P$ .

**§ 117. Larger Tables.** The little three-place tables used thus far are not accurate enough for much practical work. Four places, however, will often suffice, and five places nearly always, — though some scientific work requires even seven or eight places. There is no point in using tables which are much more accurate than the data of the problem (measurements, etc.).

A few lines are reproduced here from a typical five-place table. The labels at the bottom are to be used with the minutes at the right — as in the small tables. For example :

$$\sin 72^\circ 58' = .95613, \quad \tan 72^\circ 59' = 3.2675.$$

17°

'	Sin	Tan	Ctn	Cos	
0	.29237	.30573	3.2709	.95630	60
1	265	605	.2675	622	59
2	293	637	.2641	613	58
—	—	—	—	—	—
—	—	—	—	—	—
60	.30902	.32492	3.0777	.95106	0
	Cos	Ctn	Tan	Sin	'

72°

For intermediate values interpolate by proportional parts. Check by common sense, noting whether your interpolated value lies between the tabulated values and nearer the right one. If it does not, you may have overlooked the fact that *the cosine and cotangent grow smaller as the angle increases.*

## EXERCISES

1. Look up the five-place values of the sine, cosine, tangent, and cotangent of the following angles:

$$25^{\circ} 34', \quad 3^{\circ} 57', \quad 88^{\circ} 12', \quad 47^{\circ} 16'.$$

2. The same as Ex. 1 for the following angles, making the necessary interpolations by proportional parts:

$$5^{\circ} 9'.3, \quad 28^{\circ} 15'.6, \quad 42^{\circ} 58'.2.$$

3. In railroad construction a  $6^{\circ}$  curve is one in which a chord of 100 ft. subtends a central angle of  $6^{\circ}$ ; similarly for a  $5^{\circ}$  curve, etc.

(a) Find the radius of a  $6^{\circ}$  curve.

(b) If the radius is 2000 ft., what is the degree of curvature?

4. As in Ex. 3, find the radius of a  $4\frac{1}{2}^{\circ}$  curve. Also the curvature in a circle of radius 1 mi.

5. Find the area of the plane section common to two cylinders of radius 5 in. whose axes cross at right angles.

6. The same as Ex. 5 for two cylinders of radius 10 in., crossing at an angle of  $60^{\circ}$ .

7. A steel plate  $\frac{1}{4}$  in. thick is to be bent  $62^{\circ}$  along a certain line. How much longer will the outer surface be than the inner, if both remain flat right up to the turn?

8. The same as Ex. 7 for a plate .75 in. thick if bent  $71^{\circ} 42'$ .

9. A triangular hole through a vertical dam is 6 ft. wide at the top, and both sides are inclined  $36^{\circ} 40'$ . Find the total force of water pressure against a gate closing the hole, if the surface of the water is level with the top of the hole.

10. The top of a ladder rests against a vertical wall. The foot is pulled away at the rate of 2 ft./min. How fast is the top descending when the inclination is  $50^{\circ}$ ? (Hint: Use any length.)

11. Solve Ex. I, p. 115, for a filter whose vertex angle is  $100^{\circ}$ .

§ 118. **Oblique Triangles.** The trigonometric functions have been defined as ratios of the sides of right triangles. They can, however, be used in solving oblique triangles as well. We have merely to drop a perpendicular from some vertex to the opposite side, and work with the right triangles thus formed.

Any triangle whatever can be solved in this way if enough parts are given to fix its size and shape, — in other words, enough parts to let us draw the triangle. By elementary geometry, this is possible if we know *the three sides*, or *two sides and any angle*, or *one side and any two angles*.\*

NOTATION. In discussing these matters more fully we shall use the following very convenient notation: Capital

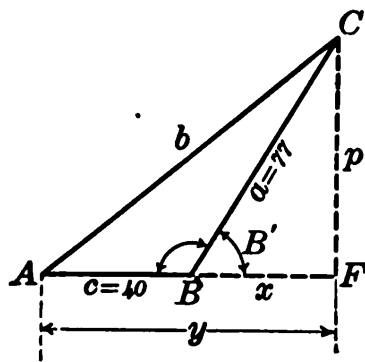

FIG. 68.

letters will denote angles, and the corresponding small letters the opposite sides. Thus, for instance,  $A$  will always stand for the angle opposite side  $a$ , and hence included between sides  $b$  and  $c$ .

Ex. I. Given  $a=77, c=40, B=121^\circ$ . Solve completely.

*Plan:* Let  $B' = 180^\circ - B = 59^\circ$ .

Solve  $\triangle BCF$  for  $p$  and  $x$ . Then

$y=40+x$ . Knowing  $p$  and  $y$ , find  $b$  and  $A$  from  $\triangle ACF$ . Find  $C$  from  $A$  and  $B$ .

*Results:*  $x=39.658, p=66.002; A=39^\circ, b=104.88, C=20^\circ$ .

Ex. II. Given  $a=75, b=65, c=80$ . Find the angles.

*Plan:* Too few parts of either right triangle are known to solve it alone. But by equating the values of  $p^2$  in the

\* To have the three angles given would not suffice, as these alone do not fix the size of the triangle. In fact, three angles are no better than two. For if two are known, the third can be found from the fact that the sum of all three is  $180^\circ$ .

two triangles, we easily find  $x$ .

Thus

$$p^2 = 65^2 - x^2 = 75^2 - (80 - x)^2,$$

which, simplified, gives  $160x = 5000$ , or  $x = 31.25$ . Then  $80 - x = 48.75$ ; and angles  $A$  and  $B$  are easily found, also  $C$ . [ $A = 61^\circ 16'$ ,  $B = 49^\circ 27'$ ,  $C = 69^\circ 17'$ .]

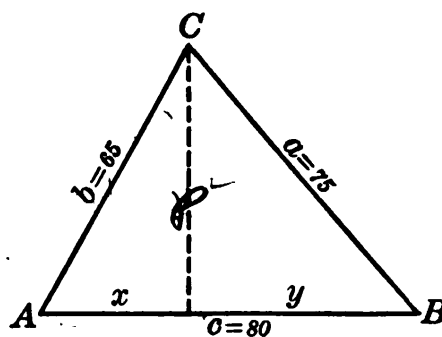

FIG. 69.

### EXERCISES

1. (a)–(b) Carry out the method of solution outlined above for the triangles in Figs. 68, 69.

2. Solve the following oblique triangles similarly:

- |                                |                      |                       |
|--------------------------------|----------------------|-----------------------|
| (I) Given $A = 17^\circ 43'$ , | $B = 82^\circ 55'$ , | $c = 689$ ;           |
| (II) Given $a = 735$ ,         | $b = 642$ ,          | $C = 53^\circ 17'$ ;  |
| (III) Given $a = 255$ ,        | $b = 388$ ,          | $A = 38^\circ 6'.5$ . |
| (IV) Given $a = 850$ ,         | $b = 950$ ,          | $c = 1200$ .          |

§ 119. **Cosine Law.** To avoid the labor of dissecting oblique triangles, let us now derive some formulas which will show how the calculation must turn out in each case.

Proceeding as in Ex. II, § 118, for an acute-angled triangle of any sides  $a$ ,  $b$ ,  $c$ , we should have:

$$p^2 = b^2 - x^2 = a^2 - (c - x)^2,$$

or solving this for  $a^2$ ,

$$a^2 = b^2 + c^2 - 2cx. \quad (8)$$

But  $x$  is the projection of  $b$  on  $c$ , and by § 113 equals  $b \cos A$ . Substituting this value for  $x$  in (8), we find:

$$a^2 = b^2 + c^2 - 2bc \cos A. \quad (9)$$

That is, *the square of one side of a triangle is equal to the sum of the squares of the other two sides, minus twice the product of those sides by the cosine of their included angle.*

This theorem is called the "Cosine Law." It should be carefully memorized. Applied to  $b$  and  $c$  it gives,

$$b^2 = c^2 + a^2 - 2ca \cos B. \quad (10)$$

$$c^2 = a^2 + b^2 - 2ab \cos C. \quad (11)$$

(Observe that in each case the formula begins and ends with the same letter.)

What modifications, if any, must be made in these formulas to apply them to obtuse angles will be discussed in § 121.

By using the Cosine Law we can solve an oblique triangle very easily if given *the three sides* or *two sides and their included angle*. We have merely to substitute the values of the given parts in equation (9), (10), or (11) as required, and solve for a required part. If some other combination of parts is given, it is best to use a different formula. (§ 120.)

Ex. I. Solve the triangle:  $a = 75$ ,  $b = 65$ ,  $c = 80$ .

By (9):  $75^2 = 65^2 + 80^2 - 2(65)(80) \cos A$ .

$$\therefore \cos A = .48077, \quad A = 61^\circ 15.8'$$

Angles  $B$  and  $C$  are found likewise by starting with  $65^2$  or  $80^2$ .

Ex. II. Solve the triangle:  $b = 750$ ,  $c = 860$ ,  $A = 40^\circ$ .

By (9):  $a^2 = 750^2 + 860^2 - 2(750)(860) \cos 40^\circ$ ,

whence  $a$  is known. Angles  $B$  and  $C$  can be found as in Ex. I, or as in § 123. Tables of squares and square roots may be used.

*Remark.* If a given angle is  $90^\circ$ , the triangle should not be solved by the Cosine Law but as a right triangle. If an unknown angle happens to be  $90^\circ$ , this fact will soon be discovered, for the square of one side will equal the sum of the squares of the other two.

§ 120. **Sine Law.** From the two right triangles in Fig. 70 we find

$$p = a \sin B, \quad p = b \sin A.$$

Hence  $a \sin B = b \sin A$ , or  $\frac{a}{\sin A} = \frac{b}{\sin B}$ .

Similar equations can be derived likewise for sides  $a$  and  $c$ , and for  $b$  and  $c$ .

$$\therefore \frac{a}{\sin A} = \frac{b}{\sin B} = \frac{c}{\sin C}. \quad (12)$$

That is, *the three sides of a triangle are proportional to the sines of the opposite angles.* [Memorize.]

What, if any, modifications are necessary when the triangle contains an obtuse angle will be discussed in § 121.

By using this "Sine Law," we can solve an oblique triangle easily if given a side and two angles, or two sides and the angle opposite one of them. In the latter case there are often two possible triangles, one of which involves an obtuse angle. This case is postponed to § 123.

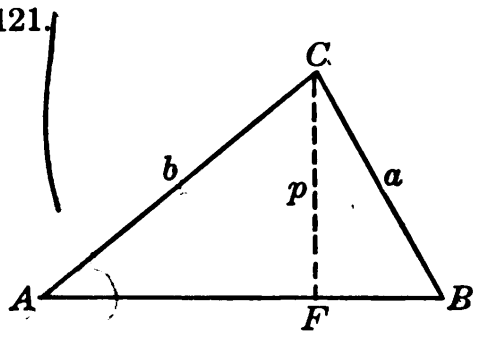

FIG. 70.

Ex. I. Solve the triangle:  $b = 750$ ,  $A = 40^\circ$ ,  $C = 80^\circ$ . The third angle is known at once:  $B = 60^\circ$ .

$$\frac{a}{\sin 40^\circ} = \frac{750}{\sin B} = \frac{c}{\sin 80^\circ}. \quad (\text{Sine Law.})$$

One of these equations gives  $a$  and the other gives  $c$ .

*Remarks.* (I) When the two given angles are complementary, or one of them is  $90^\circ$ , the triangle should be solved as a *right triangle*.

(II) The Sine Law will not solve a triangle in the cases covered by the Cosine Law, though it may be helpful after some unknown part has been found. The simplest rule as to which law to use in solving any given triangle is this: Use the Cosine Law if given the *three sides* or *two sides and their included angle*; and the Sine Law in *all other cases*.

### EXERCISES

1. When should the cosine law be used to solve a triangle? The sine law?

2. Given  $b = 450$ ,  $A = 67^\circ 23'$ ,  $C = 41^\circ 34'$ . Find  $a$ ,  $c$ ,  $B$ .

3. Given  $a=600$ ,  $b=750$ ,  $C=40^\circ$ . Find  $c$ ,  $A$ ,  $B$ .
4. Given  $a=65$ ,  $b=75$ ,  $c=80$ . Find  $A$ ,  $B$ ,  $C$ , — independently of one another. Check by adding.
5. To find the distance from a gun ( $G$ ) to a target ( $T$ ) a line  $GO=2375$  yd. long was measured to an observation post,  $O$ , and angles  $TGO$  and  $TOG$  were measured as  $72^\circ 15'$  and  $80^\circ 30'$ . Find  $GT$ .
6. To find the distance from a gun  $G$  to a target  $T$  beyond a hill an observer at  $O$  found by a range finder  $GO=2037$  yd.,  $OT=3258$  yd.,  $\angle TOG=69^\circ 25'$ . Find  $GT$ .
7. On a certain day the distances of the earth and Venus from the sun were 90,200,000 mi. and 66,200,000 mi. respectively. The angle  $ESV$  between their directions was  $69^\circ 45'$ . Find  $EV$ , their distance apart, at that time.
8. Two forces of 50 lb. and 80 lb. have an included angle of  $120^\circ$ . Find their resultant force and its direction.
9. Solve Ex. 3, p. 118, if the airplane descends at an angle of  $20^\circ$ .

§ 121. **Sine and Cosine of an Obtuse Angle.** The definitions of the sine, cosine, etc., which we have been using,

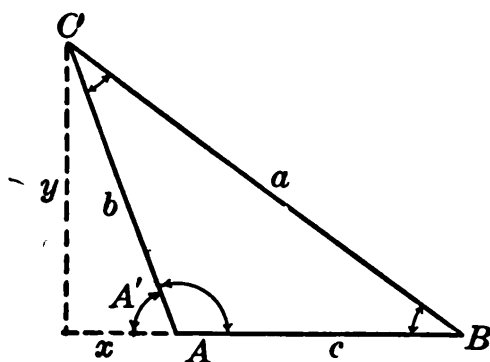

FIG. 71.

would be meaningless in the case of an *obtuse* angle. For we could not even get such an angle into a right triangle, — much less speak of the “opposite leg,” “hypotenuse,” etc.

Later on (§ 253), the definitions will be restated in a form applicable to angles of any size whatever. But for present purposes it will suffice to agree arbitrarily to let  $x$ ,  $y$ , and  $b$  in Fig. 71 take the place of the adjacent leg, opposite leg, and hypotenuse in the former definitions, thus making

$$\sin A = \frac{y}{b}, \quad \cos A = \frac{x}{b}. \quad (13)$$

We further agree to regard  $x$  as negative, as it runs in the reverse direction from the actual side of  $\angle A$ .



With these agreements we observe these facts :

**Sine of an obtuse  $\angle$  = Sine of the supplementary acute  $\angle$  (14)**

**Cosine of an obtuse  $\angle$  = - Cosine of supplementary acute  $\angle$ .**

*E.g.*      $\sin 160^\circ = \sin 20^\circ,$                       $\cos 160^\circ = -\cos 20^\circ,$   
               $\sin 100^\circ = \sin 80^\circ,$                       $\cos 100^\circ = -\cos 80^\circ,$  etc.

These agreements have been made arbitrarily, but there is good reason for adopting them: *They make the Sine Law and Cosine Law valid for obtuse-angled triangles, as well as acute.*

*Proof.* In the large right triangle of Fig. 71

$$y = a \sin B.$$

But by (13) :

$$y = b \sin A.$$

Equating these we get finally the Sine Law :

$$\frac{a}{\sin A} = \frac{b}{\sin B}, \text{ etc.}$$

Also in Fig. 71, since  $x$  is negative, the base of the large right triangle is  $c - x$ .

$$\therefore a^2 = y^2 + (c - x)^2 = y^2 + x^2 - 2cx + c^2.$$

Or, since

$$y^2 + x^2 = b^2, \text{ and } x = b \cos A,$$

$$\therefore a^2 = b^2 + c^2 - 2bc \cos A.$$

Thus the Sine Law and Cosine Law are both valid.

**§ 122. Solving Obtuse-angled Triangles.** In solving any triangle, then, whether acute-angled or obtuse-angled, we use the same formulas. But in looking up the sine or cosine of an obtuse angle, we must remember the relations (13) above.

**Ex. I.** Solve the triangle:  $A = 110^\circ, B = 40^\circ, b = 75.$

$$\frac{a}{\sin 110^\circ} = \frac{75}{\sin 40^\circ} = \frac{c}{\sin 30^\circ} \text{ (Sine Law.)}$$

To look up the sine of  $110^\circ$ , simply look up the sine of the supplement  $70^\circ$ , — which it equals by (13). Then proceed as formerly.

Ex. II. Solve the triangle:  $A = 110^\circ$ ,  $b = 75$ ,  $c = 95$ .

$$a^2 = 75^2 + 95^2 - 2(75)(95) \cos 110^\circ. \quad (\text{Cosine Law.})$$

To look up  $\cos 110^\circ$ , merely find  $\cos 70^\circ$  and prefix a negative sign. (This will make the final term in the equation positive, and  $a^2$  greater than  $b^2 + c^2$ , — as it should be, by Fig. 71.)

When  $a$  is known, find angles  $B$  and  $C$  by the Sine Law.

§ 123. **Solving for an Angle.** If we find from a triangle that the cosine of an angle is negative, this means that the angle is obtuse.

For instance, if  $\cos A = -.76604$ , then  $A$  is obtuse, and its supplement  $A'$  has its cosine equal to  $.76604$ . By the table  $A' = 40^\circ$ ; hence  $A = 140^\circ$ .

When we find from a triangle the value of the sine of an angle, the angle may be acute, or may be obtuse. For

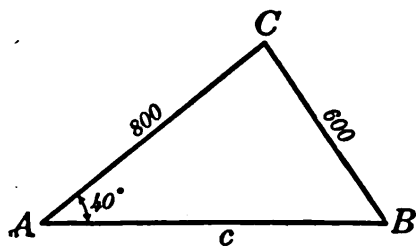

instance, if  $\sin B = .34202$ , this may mean either that  $B = 20^\circ$ , — by tables, — or that  $B = 160^\circ$ . Both values should be tested out. (This is the “ambiguous case” of elementary geometry.)

Ex. I. Solve the triangle:  $a = 600$ ,  $b = 800$ ,  $A = 40^\circ$ .

$$\frac{600}{\sin 40^\circ} = \frac{800}{\sin B} = \frac{c}{\sin C}$$

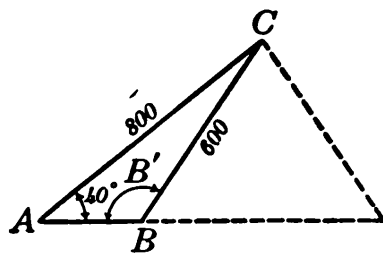

FIG. 72.

This gives  $\sin B = .85705$ , whence  $B$  is either  $58^\circ 59'$ , or the supplement of this angle, viz.,  $B' = 121^\circ 1'$ .

There are two possible triangles, both having the given parts  $a$ ,  $b$ , and  $A$ .\*

In one of these triangles,  $A = 40^\circ$ ,  $B = 58^\circ 59'$ , and hence

\* When this case arises in a practical problem, we have to decide by means of additional information which triangle is the one we want.

$C = 81^\circ 1'$ ; etc. In the other,  $A = 40^\circ$ ,  $B = 121^\circ 1'$ , and hence  $C = 18^\circ 59'$ ; etc.

*N.B.* If the larger of the two given sides were opposite the given angle, only one triangle would be possible. (Test this by construction.) The fact would be discovered automatically in the process of solving: the second value of  $B$  would be too large to go into a triangle with  $\angle A$ .

EXERCISES

1. Look up the sine and cosine of  $108^\circ$ ;  $165^\circ 20'$ ;  $150^\circ 12'.7$ ;  $128^\circ 51'.2$ .

2. Find the angles whose cosines are:  $-.92609$ ,  $-.42683$ , and  $-.10275$ . Also find the obtuse angles whose sines are:  $.39741$ ,  $.81049$ , and  $.22654$ .

3. Two given forces of 7 tons and 8 tons have an included angle of  $60^\circ$ . Find the magnitude of their resultant.

4. Two given forces of 200 lb. and 300 lb., acting at a common point, are balanced by a single force of 400 lb. Find the angle between the given forces.

5. Mt. St. Helens and Mt. Jefferson are respectively 53 mi. and 74 mi. from Portland, Ore., the angle between their directions being  $115^\circ 31'$ . Find their distance apart.

6. Find the distance  $AB$  through a hill if  $AC = 600$  ft.,  $BC = 700$  ft., and angle  $ACB = 102^\circ 17'$ .

7. Find the distance  $AB$  across a pond if  $AC = 495$  ft.,  $\angle BAC = 30^\circ$  and  $\angle ACB = 105^\circ 52'$ .

8. Solve the triangles some of whose parts are given below for the missing parts:

	$a$	$b$	$c$	$A$	$B$	$C$
i.	725	483	467			
ii.	93.6	81.5	65.2			
iii.	8.35	6.51				$32^\circ 17'$
iv.		.927	1.035	$138^\circ 15'$		
v.		6845	5728		$43^\circ 12'.8$	
vi.	38.9		59.4	$29^\circ 48'$		
vii.	9806				$92^\circ 13'$	$26^\circ 39'.2$
viii.	.0637			$14^\circ 57'$		$86^\circ 23'$

9. (i)-(viii). Find the area of each triangle in Ex. 8, (i)-(viii).

§ 124. **Successive and Simultaneous Triangles.** To find an unknown distance or angle, we often have to solve two triangles in succession, or else obtain simultaneous equations from two triangles.

Ex. I. Find  $x$  in Fig. 73; given  $A = 20^\circ$ ,  $B = 30^\circ$ ,  $AB = 2000$  (ft.).

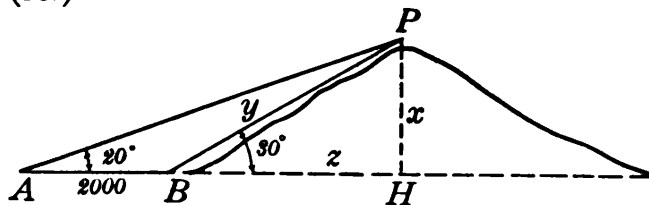

FIG. 73.

(1) *Solution by successive triangles.*

In  $\triangle ABP$ ,  $\angle P = 10^\circ$  (since  $\angle B = \angle A + \angle P$ ).

$$\therefore \frac{y}{2000} = \frac{\sin 20^\circ}{\sin 10^\circ} = \frac{.34202}{.17365},$$

whence  $y = 3939.2$ . Then in  $\triangle BPH$ ,  $x = y \sin 30^\circ = 1969.6$ .

(2) *Solution by simultaneous right triangles.*

In  $\triangle AHP$ :  $2000 + z = x \operatorname{ctn} 20^\circ = x(2.7475)$ .

In  $\triangle BHP$ :  $z = x \operatorname{ctn} 30^\circ = x(1.7321)$ .

$$\therefore 2000 = x(1.0154), \quad [\text{subtracting}]$$

$$\therefore x = \frac{2000}{1.0154} = 1969.6.$$

Observe here that  $\operatorname{ctn} 30^\circ - \operatorname{ctn} 20^\circ$  does not equal  $\operatorname{ctn} 10^\circ$ ; and that  $\sin 20^\circ$  does not equal twice  $\sin 10^\circ$ .

### EXERCISES

1. In Fig. 73 change the angles to  $15^\circ 3'$  and  $25^\circ 46'$  and the given distance to 3000 ft., and find  $x$ .

2. Two houses in line with the base of a hill are 4000 ft. apart on level ground. Observed from the hilltop they have depression angles of  $11^\circ 2'$  and  $18^\circ 55'$ . Find the height of the hill.

3. Two boat landings 3000 ft. apart on the farther side of a river are  $61^\circ$  and  $70^\circ 40'$  downstream as seen from a landing on this side. How wide is the river?

§ 125. **Summary of Chapter V.** In a right triangle the ratios of the sides will vary in a definite way with either acute angle; and are consequently *functions* of either angle.

By using the tabulated values of these functions (sine, tangent, etc.), we can solve right triangles, — and also oblique triangles, by dropping perpendiculars or using the Sine Law or Cosine Law.\*

The sine and cosine of an obtuse angle have virtually been defined in terms of the supplementary acute angle. But no general definitions have been given for the functions of any angle whatever.

By the principle of the parallelogram of forces, all problems on equilibrium of concurrent forces reduce to triangle problems. They can be solved more easily by considering *components*. A closely related idea is that of *projections*.

In solving triangles we use the theorem that the sum of the angles of any triangle is  $180^\circ$ . You will recall from geometry that the proof of this theorem rests upon the *assumption* that through a given point one and only one line can be drawn parallel to a given line.

This assumption is *not certainly known to be true*. There are “Non-Euclidean” geometries, perfectly logical, in which the assumption is denied. According to these geometries, the angle-sum differs from  $180^\circ$ , — but imperceptibly in triangles of ordinary size. *No one knows which system of geometry is true* of the space in which we live, but the “Euclidean” geometry and trigonometry which you have studied are *simpler* than the others, and are always used in practical work.

§ 126. **Our Next Step.** So much numerical calculation is necessary in solving triangles, in finding the values of derivatives and integrals, and in other scientific work, that it is imperative to know the best methods of computing. This matter will be considered in the next chapter.

Again, there are many scientific problems which use

\* The tables were calculated approximately in ancient times by means of certain formulas, but were greatly enlarged and improved in the sixteenth century, chiefly by G. J. Rheticus, a German.

trigonometry, not in solving triangles, but in studying how some quantity varies. There we must know how fast the functions sine, tangent, etc., change as the angle changes. That is, we must know the *derivative* of each function. We shall deal with this question in Chapters X–XI; and shall incidentally find formulas suitable for calculating the tables.

## EXERCISES

1. The hypotenuse and one leg of a right triangle are respectively 104 in. and 96 in. Find without tables all four functions of the smaller acute angle.
2. What is the slope of a line whose inclination is  $17^\circ 43'$ ?
3. What is the inclination of a mountain trail if the grade is 8%? What if 100%?
4. A projectile fell in such a way that the slope of its path on striking was .8. If it struck rising ground whose grade was 15%, at what angle did its path meet the ground?
5. An invisible target is 12,000 yd. east and 1360 yd. north of a gun. How far away is it, and in just what direction?
6. A color placed 40 cm. to one side and 90 cm. ahead of an observer was seen incorrectly. What was the angle from the central line of vision?
7. If two cylindrical tunnels of diameter 20 ft. cross at an angle of  $50^\circ$ , what is the area of the common plane section? Also the longest diameter of that section?
8. (a) Look up the sine and cosine of  $110^\circ$ ,  $169^\circ 42'$ ,  $128^\circ 18'.2$ .  
(b) Find  $\angle A$  if  $\cos A = -.09875$ , and two possible values of  $\angle B$  if  $\sin B = .10627$ .
9. A triangle  $ABC$  on level ground has  $B = 60^\circ$ ,  $C = 102^\circ$ ,  $a = 300$  ft. Find the height of a tree standing at  $A$ , if the elevation angle of its top, observed from  $B$ , is  $7^\circ 35'$ .
10. If the sides of a triangle are 75, 80, and 95, find the smallest angle.
11. Two forces of 50 lb. and 80 lb. have a resultant of 100 lb. Find their included angle.
12. At a certain time the distances of the earth and Mars from the sun were respectively 91,100,000 mi. and 138,600,000 mi., the angle  $ESM$  between their directions being  $152^\circ 4'$ . Find  $EM$ , their distance apart at that time.

13. A field is a parallelogram with sides 30 and 20 chains long, and an area of 42 acres. Find the length of its shorter diagonal. (1 acre = 10 sq. ch.)

14. Find by measurement and by trigonometry side  $c$  of a triangle if  $a=315$ ,  $b=521$ , and  $C=40^\circ$ .

15. Find the perimeter and area of a regular octagon circumscribed about a circle of radius 25 ft.

16. A horizontal cylindrical oil tank has an inner diameter of 10 ft. and length of 25 ft. Find the volume of oil in it when the oil is 8 ft. deep in the middle.

17. A long horizontal rod weighing 4 lb. per ft. is to carry a load of 100 lb. two feet from one end which rests on a pier. The other end is to be supported by a vertical cable. For what length of rod ( $x$  ft.) will the pull in the cable ( $F$  lb.) be least?

18. Draw to scale a triangle whose sides are 25, 30, and 40 units. Measure the smallest angle. A student tried to calculate this angle as follows:

$$\cos A = \frac{30}{40} = .750,$$

$$\therefore A = 41^\circ 25'.$$

What is wrong with this method?

19. An opening 6 feet square passes vertically through a ship's deck at a place where the deck's slope is .07 going forward and  $-.04$  going outboard across-ship. How much higher is the highest corner of the opening than the lowest?

20. An oblique cylinder has a vertical height of 3 in. and circular bases of radius 2 in. The center of the upper base is directly over a point on the circumference of the lower. Find the longest and shortest diameter of a plane section of the cylinder passed at right angles to the axis.

21. Given  $b=10021$ ,  $A=48^\circ 59'$ ,  $C=76^\circ 3'$ ; find the other parts.

22. Two forces  $OA = 16$  lb. and  $OB = 10$  lb. have an included angle of  $120^\circ$ . Find their resultant  $R$ , and the angle which it makes with  $OA$ . Check by a protractor.

23. Like Ex. 22 but with  $OA = 125$  lb.,  $OB = 99.8$  lb., and the included angle equal to  $50^\circ$ .

24. Find  $TC$  (the height of the mountain top in the figure above), if  $AB = 1$  mi., and  $A, B, C$  are in a horizontal plane.

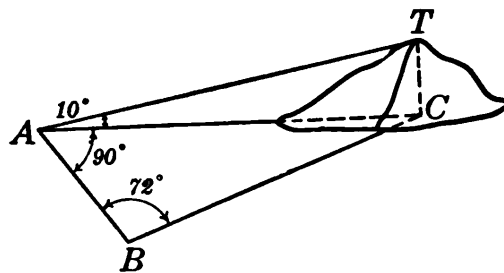

25. Like Ex. 24, but making  $AB = 3875$  ft.,  $\angle BAC = 82^\circ 23'$ ,  $\angle ABC = 91^\circ 40'$ , and the elevation angle at  $A = 4^\circ 45'$ .

26. A 35-foot flag-pole on top of a building is observed from a point  $P$  on a level street to have elevation angles of  $50^\circ$  and  $45^\circ$ , top and bottom. How far is  $P$  from a point on the ground directly below the pole?

27. A tree standing erect on a hillside whose inclination is  $18^\circ 12'$  subtends at two points  $A$  and  $B$  directly in line down the incline angles of  $10^\circ 25'$  and  $15^\circ 40'$ . If  $AB = 399.6$  ft., find the height of the tree.

28. Find  $\angle A$  from the equation  $(\tan A)^3 + 3(\tan A) = 47$ , first letting  $\tan A = x$ . (Equations like this often arise in finding the position of a comet.)

[29.] Two stars  $A$  and  $B$  are at distances  $3.5 \times 10^{15}$  and  $4 \times 10^{15}$  miles from the earth; and the angle between their directions (from here) is  $60^\circ$ . Find their distance apart.

[30.] The sides of the triangular base of a prism are  $7 \times 10^{-4}$ ,  $4 \times 10^{-4}$ , and  $5 \times 10^{-4}$  cm. Find the largest angle.

31. A 20-foot ladder leans against a vertical wall. If its foot is pulled away horizontally at the rate of .5 ft./sec., how fast is the top descending when the inclination is  $53^\circ 7'.8$ ?

32. The base of a solid is a quarter-circle of radius 10 in. Every vertical section parallel to one side is a triangle whose base angles are  $90^\circ$  and  $35^\circ$ . Find the volume.

33. Find the total force of water pressure against a trapezoidal dam, whose longer base ( $= 20$  ft.) is at the surface, whose acute angles are both  $70^\circ$  and whose lower base is 8 ft. below the surface.

34. Find the slope and inclination of the curve  $y = .3x^2$  at  $x = 2$ .

35. Find the vertex angle of the largest cone which can be sent by Parcel Post. (See Ex. 9, p. 34.)

36. Solve Ex. 6, p. 116, if the shape of the pile is changed so as to make the vertex angle  $110^\circ$ .

37. In Ex. 22 above, if  $OB$  increases at the rate of .4 lb./min., how fast will  $R$  be changing when  $OB = 16$  lb.?



## CHAPTER VI

### LOGARITHMS

#### NUMERICAL CALCULATION

§ 127. **Estimating Results.** In making a numerical calculation it is important to estimate the result roughly in advance. This will check any gross error, — such as misplacing the decimal point, etc.\* Moreover, for some purposes, rough estimates suffice in themselves, making accurate calculations unnecessary. The following devices are frequently useful.

(I) *To estimate a product or quotient*, use “round numbers,” and cancel when convenient.

$$E.g., \quad \frac{681.6 \times 7\,946\,000\,000}{20\,600\,000 \times (30.27)^2} = \frac{700 \times 8\,000\,000\,000}{20\,000\,000 \times 900} = 300, \text{ approx.}$$

The actual value is about 273.6; but we are much better off to know that it is *somewhere near 300* than to have no idea at all whether it is nearer, say, 5 or 5 000 000.

To make a closer estimate, notice whether each factor has been increased or decreased, and by about what fractional part. Make rough allowances accordingly.

(II) *To estimate a root*, use round numbers and group the figures according to the index of the root, as in § 12. Treat a fourth root as the square root of a square root, etc.

$$E.g., \quad \sqrt{265\,800} = \sqrt{27\,00\,00} = 500^+, = 520, \text{ say};$$

also  $\sqrt[3]{.0000\,7969} = \sqrt[3]{.000\,080} = .04^+, = .043, \text{ say}.$

\* In using a Slide Rule, an estimate is the only simple means of pointing off the result.

§ 128. **Scientific Notation.** In scientific work, numbers which are very large or small are expressed briefly in such a form as  $3.67 \times 10^{12}$ , or  $5.94 \times 10^{-8}$ , instead of being written out in full. This avoids operations with long rows of zeros or decimal places.

To write out in the ordinary way any number given in this "Scientific Notation," we simply perform the indicated multiplication, — *i.e.*, move the *decimal point* a number of places equal to the exponent, supplying as many zeros as may be needed.\* *E.g.*,

$$7.69 \times 10^6 = 7\,690\,000. \quad (\text{Point moved 6 places.})$$

$$(4.27 \times 10^{-5} = .000\,0427. \quad (\text{Point moved 5 places.})$$

Conversely, to express in "Scientific Notation" any number given in the ordinary way, we simply factor out the proper power of 10. Placing the decimal point wherever we want it, we note how many places it was moved to get it there. Thus,

$$27\,180\,000 = 2.718 \times 10^7$$

$$.000\,00483 = 4.83 \times 10^{-6}$$

For reasons which will soon appear, we usually place the decimal point *after the first significant figure*. Thus,  $2.718 \times 10^7$  is preferable to  $27.18 \times 10^6$  or  $.2718 \times 10^8$ , — unless we have to compare this number with other numbers carrying the factor  $10^6$  or  $10^8$ , or unless we need, say,  $10^6$  in order to extract a cube root evenly, etc.

In calculating with numbers expressed in scientific notation, we combine the various powers of 10 according to the laws of exponents, *viz.*,

$$(A) \text{ Multiplying: } 10^x \cdot 10^y = 10^{x+y}$$

$$(B) \text{ Dividing: } 10^x \div 10^y = 10^{x-y}$$

\* Since  $10^{-n}$  means  $1/10^n$ , multiplying by a negative power of 10 is the same as dividing by the corresponding positive power, — *i.e.*, moving the decimal point to the left.

$$(C) \text{ Finding powers: } (10^x)^n = 10^{nx}$$

$$(D) \text{ Finding roots: } \sqrt[n]{10^x} = 10^{\frac{x}{n}}$$

$$\text{Ex. I. Calculate } f = \frac{(18900\ 000)^3 \cdot (.000\ 000\ 00615)}{\sqrt[3]{34.180\ 000\ 000\ 000}}$$

$$\text{Rewritten } f = \frac{(1.89 \times 10^7)^3 \times (6.15 \times 10^{-9})}{\sqrt[3]{34.18 \times 10^{12}}} = \frac{1.89^3 \times 6.15 \times 10^{12}}{\sqrt[3]{34.18 \times 10^4}}$$

$$\text{Estimate } f = (7 \times 6 \div 3^+) \times 10^8 = 14 \times 10^8.$$

$$\text{By calculation } f = 12.794 \times 10^8.$$

Notice that the powers of 10 are combined much more easily than their coefficients 1.89, 6.15, etc. If the latter could also be expressed as powers of 10, the whole calculation would be very simple.

### EXERCISES

1. Translate into ordinary notation:  $6.54 \times 10^5$ ;  $3.91 \times 10^{-4}$ ; diameter of an "H" molecule =  $5.8 \times 10^{-8}$  cm.; weight =  $4.6 \times 10^{-24}$  gm.

2. Translate into "Scientific Notation," with the decimal point after the first digit:

$$1 \text{ day} = 86\ 400 \text{ sec.},$$

$$1 \text{ k.w.} = 10\ 000\ 000\ 000 \text{ ergs},$$

$$1 \text{ mi.} = 161\ 000 \text{ cm.},$$

$$1 \text{ cm.} = .000\ 006\ 21 \text{ mi.}$$

$$1 \text{ gm.} = .000\ 0011 \text{ ton},$$

$$1 \text{ cc.} = .000\ 0353 \text{ cu. ft.},$$

Air weighs .00129 gm./cc.; hydrogen, .000 0896 gm./cc.

In Ex. 3-9 estimate the answer very roughly. Then calculate it, accurate to three figures.

3. One wave of sodium light has a length of  $5.89 \times 10^{-5}$  cm. How many waves to 1 mi.?

4. The energy needed to raise the temperature of 1 gm. of water by  $1^\circ$  C. is  $4.16 \times 10^7$  ergs. How many tons of water can be raised  $5^\circ$  in temperature by  $9.62 \times 10^{15}$  ergs?

5. How far does light travel in 1 hr. if its velocity is  $2.999 \times 10^8$  meters/sec.?

6. Evaporating at the rate of 1 cu. ft./sec., how long would a cubic mile of ice last?

7. For each degree rise in temperature glass expands by .000025 of its volume at  $0^\circ$  C. How much expansion occurs between  $300^\circ$  and  $425^\circ$ ?

8. The distance from the sun to the earth is  $9.29 \times 10^7$  mi.; to Neptune,  $2.79 \times 10^9$  mi., and to the nearest fixed star  $2.5 \times 10^{13}$  mi.

Representing the distance to the earth by 1 inch, how far would it be on this scale to Neptune? To the nearest star?

9. 1 ft.-lb. per sec. =  $1.356 \times 10^{-3}$  kilowatts. How many cubic feet of water falling 1 ft./sec. would supply the current needed for an 80-watt lamp if only one tenth of the actual power can be converted into current?

**§ 129. Calculating by Combining Powers of 10.** We come now to the best system of numerical computation ever invented, — by which we can make calculations in a few minutes that would otherwise require days or even years.

Here is the idea: *Every number is some power of 10*, and can be expressed as such by means of certain tables. Hence to make a calculation we have merely to *combine exponents*.

For instance, suppose we wish to find  $\sqrt[11]{a^3/b}$  where  $a$  and  $b$  denote some given numbers. And suppose the tables show that

$$a = 10^{.91021}, \quad b = 10^{1.10054}.$$

We build up the required quantity as follows:

$$a^3 = 10^{2.73063} \quad (\text{Multiplying the exponent .91021 by 3.})$$

$$b = 10^{1.10054}$$

$$\therefore \frac{a^3}{b} = 10^{1.63009} \quad (\text{Subtracting the exponent 1.10054.})$$

$$\begin{aligned} \therefore \sqrt[11]{\frac{a^3}{b}} &= \sqrt[11]{10^{1.63009}} \\ &= 10^{.14819} \quad (\text{Dividing the exponent 1.63009 by 11.}) \end{aligned}$$

And when we have seen from the tables what number this final power of 10 equals, we shall have found the required root.

Notice that in using these exponents the operation of cubing  $a$  is replaced by the mere multiplication of an exponent by 3; a long division ( $a^3 \div b$ ), by the subtraction of an exponent; and the very difficult extraction of an eleventh root, by the mere division of an exponent by 11.

Very little more work would be required to find even a 67th root or a 211th root.

The tables are easily used, but to understand them thoroughly we must first note some further facts concerning powers of 10.

**§ 130. Numbers as Powers of 10.** The statement that every number is some power of 10 should perhaps be explained briefly.

Consider, for instance, the number 75, which is clearly not an integral power, being greater than  $10^1$  and less than  $10^2$ . Neither is it a fractional power. For a fractional power is a *root*; and it can be shown that extracting a root of any integral power of 10 could never give 75 exactly.

When we say that 75 is some power of 10, we mean an *irrational* power.

That is, fractional powers can be found which will approximate 75 as closely as we wish :

$$10^{1.875} = 74.99, \quad 10^{1.87506} = 74.9998, \text{ etc.}$$

And the *limit* approached by a certain sequence of such fractional powers, as the exponent approaches a certain irrational limiting value, is exactly 75.

Similarly for other positive numbers. Negative numbers will be considered later. (§§ 141, 321.)

**§ 131. Logarithm Defined.** In the equation

$$75 = 10^{1.87506\dots},$$

the exponent  $1.87506 \dots$  is called the *logarithm* of 75, written *log 75*. Thus,

$$\log 75 = 1.87506 \dots$$

In general, the logarithm of any number is *the exponent of the power to which 10 must be raised to produce the number*.

A logarithm usually consists of two parts: an integer and a decimal. The decimal is found from a table, the integer by inspection, — as will be explained shortly.

§ 132. **Logarithms of Numbers between 1 and 10.** A principle which is very basic and will be used continually is this:

*If a number  $N$  lies between 1 and 10, its logarithm consists of a decimal only.*

For  $N$  lies between  $10^0$  and  $10^1$ , and hence

$$N = 10^{0+\text{decimal}}, \quad \text{or} \quad \log N = 0 + \text{decimal}.$$

Conversely, *if  $\log N$  is a positive decimal only, then  $N$  lies between 1 and 10.* (Proof?)

§ 133. **Use of Tables.** The logarithms of numbers between 1 and 10 can be read directly from a table. The logarithms of other numbers are obtainable from them. (§ 134.)

Five-place tables are accurate enough for most purposes, and their arrangement is like that of larger tables. A part of a typical page is reproduced here.\*

$N$	0	1	2	3	4	5	6	7	8	9
150	17609	638	667	696	725	754	782	811	840	869
51	898	926	955	984	*013	*041	*070	*099	*127	*156
52	18184	213	241	270	298	327	355	384	412	441
53	469	498	526	554	583	611	639	667	696	724

*Explanation.* The first three figures of the *number* are shown in the  $N$ -column at the left, and the fourth figure in the  $N$ -line at the top. A decimal point is to be understood after the first figure in the  $N$ -column, so that these numbers are really 1.50, 1.51, etc.

The logarithms appear in the body of the table, and are understood to be decimals only, and of five places throughout. Their first two figures are printed (only occasionally) in the 0 column at the left.

\* *The Macmillan Tables* include a particularly good collection of auxiliary tables.

Ex. I. To find the logarithm of 1.502, we look opposite 150 under 2. We read 667, with 17 at the left. Hence

$$\log 1.502 = .17667, \quad \text{or } 1.502 = 10^{.17667}.$$

Ex. II. To find  $\log 1.514$ , we look opposite 151 under 4:

$$\log 1.514 = .18013, \quad \text{or } 1.514 = 10^{.18013}.$$

(The asterisk indicates that the first two figures of the logarithm have changed from 17 to 18, as the last three figures have changed from 984 to 013.)

Conversely, if we have given a logarithm and wish to find the number, we simply locate the given logarithm in the body of the table and see what number corresponds to it.

Ex. III. If given  $\log N = .18355$ , we locate this value opposite 152 and under 6.

$$\therefore N = 1.526; \quad \text{i.e.,} \quad 10^{.18355} = 1.526.$$

If a given logarithm does not appear exactly in the table, we take the one nearest to it, or else interpolate by proportional parts. (This is made easy in § 138.) Similarly if a given number has more than four places. If it has fewer than four, we mentally affix zeros; *e.g.*,  $1.5 = 1.500$ .

### EXERCISES

- Express in the language of logarithms the fact that  $7 = 10^{.84510}$ ; that  $200 = 10^{2.30103}$ .
- What is meant by saying that the logarithm of 80 is 1.90309? That the logarithm of 1.1 is .04139? Express by an equation in each case.
- Express the following numbers as powers of 10 by inspection, and state what the logarithm of each is: 1000; 10; 100; .1; .001.
- Express as powers of 10 by means of tables: 2.718; 5.68; 7.945. Translate into logarithmic notation, as  $\log 2.718 = \dots$ , etc.
- Given  $\log a = .62459$ ,  $\log b = .78017$ ,  $\log c = .01442$ ,  $\log d = .96037$ , express  $a$ ,  $b$ ,  $c$ ,  $d$  as powers of 10. Also look up their values, to the nearest fourth figure.
- What is the meaning of  $x^{\frac{5}{4}}$ ? Of  $x^{\frac{1}{16}}$ ? Of  $10^{1.9}$ ? Of  $10^{1.41}$ ? How could you find the approximate numerical values of  $10^{-5}$ ,  $10^{-25}$ ,  $10^{-125}$ , and  $10^{-75}$ , without tables?

§ 134. **Logarithms of Larger or Smaller Numbers.** The logarithm of a number greater than 10 or less than 1 can be found by using the idea of Scientific Notation.

Ex. I. 1514000 would be  $1.514 \times 10^6$ .

And 1.514, being between 1 and 10, can be found in the table:  $1.514 = 10^{.18013}$ . Multiplying this by  $10^6$  gives, on adding exponents:

$$1514000 = 10^{6.18013}, \quad \text{or } \log 1514000 = 6.18013.$$

Ex. II. .01514 would be  $1.514 \times 10^{-2}$ .

$$\therefore .01514 = 10^{.18013} \times 10^{-2} = 10^{.18013-2}.$$

For reasons to be explained presently (§ 136), it is customary in cases like this not to combine the negative integer with the positive decimal, but rather to keep the exponent expressed as a difference.

Observe that the decimal part of the logarithm is the same for all these numbers: 1.514; 1514 000; and .01514. So would it be for any other number having these same digits, 1, 5, 1, 4, in this same order. (Why?)

*To find a number when given its logarithm, we simply reverse the steps above, — as in the following examples.*

Ex. III. Given  $\log N = 4.18013$ , or  $N = 10^{4.18013}$ .

This is evidently the same as  $N = 10^4 \times 10^{.18013}$ . And the latter exponent, being a decimal only, can be found among the logarithms of the table:  $10^{.18013} = 1.514$ .

$$\therefore N = 10^4 \times (1.514) = 15140.$$

Ex. IV. Given  $\log N = .18184 - 3$ , or  $N = 10^{.18184-3}$ .

By tables this decimal power of 10, without the  $-3$ , would equal 1.52. The effect of the  $-3$  is to multiply by  $10^{-3}$ , making

$$N = 1.52 \times 10^{-3} = .00152.$$

With practice all these operations may be abbreviated and performed rapidly, — merely by inspection.

§ 135. **Summary.** (I) Every positive number is some real power of 10: the exponent of the power is the **logarithm** of the number.



(II) The integral part of a logarithm (or **characteristic**, as it is called) is found by inspection :

*For any number between 1 and 10, the characteristic is zero.*

Thus,  $1.52 = 10^{.18184}$ , or  $\log 1.52 = 0.18184$ .

*For any other number, think of its Scientific Notation.*

Thus,  $37200 = 3.72 \times 10^4 = 10^{\text{dec.}+4}$ , or  $\log 37200 = \text{dec.}+4$  ;  
and  $.00458 = 4.58 \times 10^{-3} = 10^{\text{dec.}-3}$ , or  $\log .00458 = \text{dec.}-3$ .

Of course, we need not *write out* all these steps.\*

(III) The decimal part of a logarithm (or **mantissa**, as it is called) is read from a table. It is the same for all numbers which differ only in the position of the decimal point.

(IV) *In going from a logarithm back to the number*, we locate the mantissa in the body of the table, and read off the figures in the number. If the characteristic is zero, the decimal point falls in the standard position, after the first figure. If there is a characteristic ( $\pm c$ ), the point moves to the right or left  $c$  places from the standard position.

(V) Calculations can be made by *combining powers of 10*. The work should be so arranged that the exponents to be combined will be near one another, and in a column.

Ex. I. Compute  $f = \frac{(151.4)^2 \times 6927}{\sqrt[3]{735\ 000\ 000}}$ .

$$\begin{array}{rcl} 151.4 = 10^{2.18013} & \therefore (151.4)^2 = 10^{4.36026} & \\ & 6927 = 10^{3.84055} & \\ & \text{Product} = 10^{8.20081} & \\ 735\ 000\ 000 = 10^{8.86629} & \therefore \sqrt[3]{735\ 000\ 000} = 10^{2.95543} & \\ & \therefore f = 10^{5.24538} & \end{array}$$

Looking up the mantissa .24538 we find 1.759. The characteristic 5 moves the point five places. Hence  $f = 175\ 900$ .

\* Simply point with the pencil at the standard position of the decimal point after the first significant figure, and count up the power of 10 which would factor out. Try this on the following :

$$\begin{array}{rcl} 6981 = 10^{3+\text{dec.}} & 25\ 000\ 000 = 10^{7+\text{dec.}} & \\ 28.9 = 10^{1+\text{dec.}} & 314.16 = 10^{2+\text{dec.}} & \\ .657 = 10^{\text{dec.}-1} & .000\ 000\ 99 = 10^{\text{dec.}-7} & \end{array}$$

*Remark.* Many rates, maxima, areas, etc., as found by differentiation or integration, must be calculated numerically by means of logarithms. And that is possible only because a logarithm varies with its number in a definite way. The tables show this variation: in other words, they give the values of a certain function called the "logarithm."

## EXERCISES

1. Express these numbers as powers of 10:

(a) 876.5;      7504 000. (First write the Scientific Notation.)

(b) 49.12;      582 000. (Think of the Scientific Notation.)

What is the logarithm of each of these numbers?

2. Write as powers of 10 the numbers whose logarithms are

3.49568,      7.91219,      2.07734,      1.84510.

Look up each number, reading the fourth figure which is nearest.

3. Find the product of the numbers in 1 (a). Likewise in 1 (b). Check each by actual multiplication.

4. Make each of the following calculations (to four figures) by expressing the given numbers as powers of 10, in a vertical column, and combining. Estimate each result roughly in advance as a check.

(a)  $52.89 \times 4791 \times 3.809$ ,

(b)  $(7.058)^3 \times 20650$ ,

(c)  $986500 \div 287.4$ ,

(d)  $\sqrt[4]{86.17}$ ,

(e)  $(89.87)^2 \times 601.8 \div 4960$ ,

(f)  $\sqrt{1750} \div 12.5$ ,

(g)  $(30.59)^7 \div \sqrt{6031000}$ ,

(h)  $100000 \div (419.9 \times 9.083)$ ,

(i)  $\sqrt[3]{\frac{754.4}{31.4 \times 4.146}}$ ,

(j)  $\frac{(5.6)^4 \times 72.83}{\sqrt{98020000}}$ .

5. Proceed as in Ex. 1 (a) for the numbers .00487 and .9216; also as in 1 (b) for .0658, .000 097, and .000 5108.

6. Find what numbers the following powers of 10 equal:

$10^{-8.1305-2}$

$10^{.49136-7}$

$10^{-.73062-1}$

7. Calculate: (a)  $.0001683 \times 246700$ ; (b)  $.009875 \div 5.169$ .

8. Look up  $\log 2.5486$ , interpolating by proportional parts.

9. Find the slope of the curve  $y = 1.73 x^{\frac{1}{2}}$  at  $x = 20$ .

10. Plot a graph showing how  $\log x$  varies with  $x$  from  $x = 1$  to  $x = 10$ . If the logarithms of two numbers were known exactly, would inter-

polation by proportional parts give too large or too small a value in finding an intermediate logarithm?

§ 136. **Avoiding Negative Mantissas.** It would be inconvenient at the end of a calculation to come out with such a result as

$$N = 10^{-.39685},$$

for the tables give only positive mantissas. And if we used the definition of a negative power, writing  $N = 1 \div 10^{.39685}$ , we should have to look up the latter power and then perform a long division to get  $N$ .

To avoid such difficulties we take care to keep our mantissa positive at every step of a calculation. This can be done, even when we have to subtract a larger logarithm from a smaller, by using a simple device:

*Increase the smaller logarithm by some integer, making it now the larger, and at the same time indicate the subtraction of a like integer, so as to keep the net value unchanged.*

Ex. I. Calculate  $x = \frac{1.58}{4326}$ . [Estimate,  $x = .00035$ .]

By tables:  $1.58 = 10^{.19866}$  and  $4326 = 10^{3.63609}$ .  
Increase the first exponent by 4, with  $-4$  affixed.  
Subtract the exponent 3.63609.

$$\begin{array}{r} 1.58 = 10^{4.19866-4} \\ 4326 = 10^{3.63609} \\ \hline x = 10^{.56257-4} \end{array}$$

Look up the resulting positive mantissa, and point off according to the characteristic  $-4$ .

$$x = .0003652.$$

§ 137. **Operations with Negative Characteristics.** When looking up the logarithm of a small number, — as already stated, — we do not combine the negative characteristic with the positive decimal, but merely indicate the subtraction, in the form, say,  $.01514 = 10^{.18013-2}$ . This procedure avoids negative mantissas, and also saves labor.

In working with such combination logarithms, there are a few points to be looked out for, as shown in the following examples.

(I) *Raising to a power*: say  $x = (.4074)^5$ .

By tables:  $.4074 = 10^{.61002-1}$ .  $\therefore x = 10^{3.05010-5}$ .

(Observe that we have multiplied the *entire* exponent by 5, — of course.)

The resulting exponent is clearly equal to  $.05010 - 2$ , simply dropping 3 — 3, or zero. Looking up the mantissa  $.05010$  and pointing off according to the  $-2$ , we find  $x = .01122^+$ .

(II) *Extracting a root*: say  $x = \sqrt[3]{.1998}$ .

By tables:  $.1998 = 10^{.30060-1}$ .

Dividing this exponent by 3 would give  $.10020 - .33333$ , producing a negative mantissa. To avoid this, we may add  $2 - 2$  to the original logarithm, making it  $2.30060 - 3$ , still the same value. Then we can divide evenly:

$$x = \sqrt[3]{10^{2.30060-3}} = 10^{.76687-1} = .5846 \text{ (by tables).}$$

To extract any other root we should likewise make the negative integer exactly divisible by the index of the root. Of course, we must do this without changing the value of the combination, *i.e.*, by adding zero in the form  $n - n$ .

(III) *Dividing*: say  $x = \frac{.003166}{.06314}$ . [Est.,  $.05^+$ ]

By tables:

$$.003166 = 10^{.50051-3}$$

$$.06314 = 10^{.80030-2}$$

Modified form (adding  $1 - 1$ ):

$$.003166 = 10^{1.50051-4}$$

$$.06314 = 10^{.80030-2}$$

The subtraction gives finally:

$$x = 10^{.70021-2} = .05014.$$

### EXERCISES

1. If we have to subtract  $-3$  from  $-1$  in making a calculation, what will this give?

2. Estimate the following values roughly, and then calculate to four significant figures:

- |   |                         |                                  |
|---|-------------------------|----------------------------------|
| (a) $43.65 \div 917.8$ ,                | (b) $.5127 \div .398$ , | (c) $.0683 \div 149.5$ ,         |
| (d) $.002957 \times .6849$ ,            | (e) $(.287)^5$ ,        | (f) $.07814 \times .00997$ ,     |
| (g) $\sqrt[3]{.000\ 000\ 007}$ ,        | (h) $\sqrt[3]{.007}$ ,  | (i) $2\sqrt[3]{.1}$ ,            |
| (j) $\sqrt[3]{.00049728} \times .198$ , | (k) $(.4657)^{11}$ ,    | (l) $(.1624)^{15}(1.642)^{30}$ . |

3. Likewise calculate the following:

(a)  $9.875 \times .06543 \times 21.37$ ,

(b)  $.007968 \times \sqrt{.4499} \times \sqrt[3]{63.17}$ ,

(c)  $\frac{6587 \times .04659}{762.8 \times .561}$ ,

(d)  $\frac{\sqrt[3]{8725000}}{48.75 \times .548}$ .

4. Estimate and calculate Young's modulus for steel from the formula  $Y = mgl/(\pi r^2 s)$ , if  $m = 1005$ ,  $g = 980$ ,  $l = 87$ ,  $r = .0249$ , and  $s = .02183$ .

5. The diameter ( $d$  in.) which a water pipe  $L$  ft. long must have to discharge  $Q$  cu. ft. per sec. under a head of  $H$  ft. is  $d = 5.75 \sqrt[4]{FLQ^2/H}$  where  $F$  is a friction factor. If  $F = .0197$ ,  $L = 250$ ,  $Q = 7.5$ , and  $H = 11.25$ , find  $d$ . [If you can mentally find the product  $FL$  or replace  $Q^2$  by its value, the logarithmic work will be shortened.]

§ 138. **Tables of Proportional Parts.** In the margins of logarithmic tables there are small auxiliary tables which make interpolation easy.

Ex. I. Find  $\log 1.5146$ .

The required logarithm lies between .18013 and .18041, which differ by 28 (units of the fifth place.) Select the marginal table headed 28. This tells how much to add to the smaller tabulated logarithm [.18013] because of any fifth figure in the given number. In our example the fifth figure is 6: add 16.8 (*i.e.*, 17), making

$$\log 1.5146 = .18013 + .00017 = .18030.$$

Ex. II. Find  $N$  if  $\log N = .18037$ .

The next smaller logarithm in the table is .18013, belonging to 1.514. (This gives the first four figures of the required number  $N$ .)

Now  $\log N$  exceeds .18013 by 24 units. Hence our problem is this: *What fifth figure* in  $N$  would add 24 to the logarithm, in a total difference of 28? The nearest to 24 shown in the marginal table is 25.2 and this is opposite 9, — the required fifth figure of  $N$ . Thus  $N = 1.5149$ .

*Remarks.* (I) In using these auxiliary tables, note carefully which you are finding: how much to *add* to a logarithm, or what fifth figure to *affix* to a number. With practice the operations can all be performed mentally, and only the final result written.

28	
5TH FIG.	ADD TO LOG
1	2.8
2	5.6
3	8.4
4	11.2
5	14.0
6	16.8
7	19.6
8	22.4
9	25.2

(II) These auxiliary tables are based upon proportional parts. If ten units in the fifth place of the number (one unit in fourth place) make a difference of 28 in the logarithm, then 3 units make a difference three tenths as large, or a difference of 8.4.

(III) What if a given number has six figures, say 1.51436? The 36 units of the *sixth* place will change the logarithm by  $.36 \times 28$ . By the little table,  $.3 \times 28 = 8.4$  and  $.06 \times 28 = 1.68$ . Thus  $.36 \times 28 = 8.4 + 1.68 = 10.08$ . Simply add 10. (There is almost no chance of securing greater accuracy by preserving figures beyond the fifth place.)

### EXERCISES

Get all results in the following exercises accurate to the nearest unit in the fifth place.

1. Look up the logarithms of :

387.26,          97193,          1.0487,          .0056207.

2. Find the numbers whose logarithms are :

.30113,          8.47702,          8.69014 - 10,          4.96046 - 10.

3. Estimate and calculate :

$$(a) \frac{(116.3)^2(8.713)}{21739}, \quad (b) \frac{\sqrt[3]{3125}}{9.8751 \times 82.3}$$

4. The time of swing of a pendulum is  $T = 2\pi\sqrt{l/g}$ . Estimate and calculate  $T$  if  $l = 1$  and  $g = 32.083$ .

5. The amount of  $\$P$  with 5% compound interest after  $n$  years is  $A = P(1.05)^n$ . Find  $A$  if  $P = 4750$  and  $n = 30$ .

6. In Ex. 5 find the principal  $\$P$  required to yield an amount of  $\$10000$  after 20 years.

7. Find the radius of a steel sphere weighing 1 ton, if 1 cu. ft of steel weighs 480 lb.

8. Find the area under the curve  $y = .85x^{\frac{2}{3}}$  from  $x = 1$  to 8.

[9.] Translate into logarithmic notation in a parallel column each of the equations involving a power of 10 which was used in Ex. 3 (a). Thus :

$$116.3 = 10^{2.06558} \quad | \quad \log 116.3 = 2.06558,$$

etc. How was the "log" of the square obtained from the "log" of the number? The "log" of the product from the "logs" of the factors? The "log" of the fraction?

§ 139. **Laws of Logarithms.** Since logarithms are exponents, they combine according to the usual laws of exponents. These are already familiar; but in what follows it will be convenient to have them restated in logarithmic form, as follows:

(I) *The logarithm of a product equals the sum of the logarithms of the factors:*

$$\log (ac) = \log a + \log c.$$

(II) *The logarithm of a quotient equals the difference of the logarithms of the dividend and divisor:*

$$\log \frac{a}{c} = \log a - \log c.$$

(III) *The logarithm of a power of a number equals the index of the power times the logarithm of the number:*

$$\log a^n = n \log a$$

(IV) *The logarithm of a root of a number equals the logarithm of the number, divided by the index of the root:*

$$\log \sqrt[n]{a} = \frac{1}{n} \log a.$$

If a formal proof of these laws is desired, it can be given as in the following illustrations:

**PROOF OF (I):**

If  $\log a = x$  and  $\log c = y$ ,  
*i.e.*, if  $a = 10^x$  and  $c = 10^y$ ,  
 then  $ac = (10^x)(10^y) = 10^{x+y}$ ,  
 which shows that  $\log ac = x + y = \log a + \log c$ .

**PROOF OF (IV):**

If  $\log a = x$ ,  
*i.e.*, if  $a = 10^x$ ,  
 then  $\sqrt[n]{a} = \sqrt[n]{10^x} = 10^{\frac{x}{n}}$ ,  
 which shows that  $\log \sqrt[n]{a} = \frac{x}{n} = \frac{1}{n} \log a$ .

The proofs of (II) and (III) are similar. (Ex. 1, p. 205.)

**§ 140. Abbreviated Form.** In calculating by combining powers of 10, the actual operations are performed upon the exponents or logarithms. Hence it would suffice to set down the logarithms alone, and work with them. This should, however, be done in an orderly manner and labeled clearly.

The following example shows a calculation worked out with powers of 10 as heretofore, and the same calculation in the abbreviated form.

Ex. I. Calculate  $x = \sqrt{\frac{(25.89)^3(.0125)}{927}}$ .

*Exponential Form*

$$\begin{array}{l} 25.89 = 10^{1.41313} \\ \hline 25.89^3 = 10^{4.23939} \\ .0125 = 10^{-.09691-2} \\ \hline \text{product} = 10^{4.33630-2} \\ 927 = 10^{2.96708} \\ \hline \text{fraction} = 10^{1.36922-2} \\ x = 10^{.68461-1} \\ \hline \therefore x = .48373. \end{array}$$

*Logarithmic Form*

No.	Log.
25.89	1.41313
25.89 <sup>3</sup>	4.23939
.0125	.09691 - 2
prod.	4.33630 - 2
927	2.96708
frac.	1.36922 - 2
$x$	.68461 - 1
$\therefore x = .48373.$	

The latter form is the one which we shall use hereafter.\*

**§ 141. Arrangement of Work.** Before looking up any logarithms for a calculation, we should always plan the work in full and lay out a "skeleton form," providing a place for each step and labeling it. We can then devote our entire attention to the tables and to the necessary arithmetic. This will save time, eliminate many blunders, and keep the calculation in a presentable form.

The following example shows an arrangement of work pretty satisfactory for the more complicated calculations.

\* In using this be careful not to write the = sign between a number and its logarithm. The resulting confusion would be serious sometimes.



Ex. I. Calculate  $x = \frac{\sqrt{.5212}(13.953)^{\frac{5}{3}}}{\sqrt{(8.2)^5(45.187)^3}\sqrt[3]{.0973}}$

Plan: The logarithm of  $x$  will be obtained as follows:

$$\log x = [\frac{1}{2} \log a + \frac{5}{3} \log b] - \frac{1}{2} [5 \log c + \log d + \frac{1}{3} \log e],$$

where  $a, b, \text{etc.}$ , denote the given numbers, .5212, etc.

The following "skeleton form" (printed in black type) provides for these steps:

No.	Log	No.	Log	No.	Log
(a) <b>.5212</b>	$\frac{19.71700-20}{9.85850-10}$   <b>2</b>	$\sqrt{a}$	9.85850-10	$c^5$	4.56905
		$b^{\frac{5}{3}}$	1.90778	$d$	1.65501
(b) <b>13.953</b>	$\frac{1.14467}{5.72335}$ $\times 5$   <b>3</b>	Nu.	11.76628-10	$\sqrt[3]{e}$	9.66270-10
	$\frac{5.72335}{1.90778}$			Prod.	5.88676   <b>2</b>
(c) <b>8.2</b>	$\frac{0.91381}{4.56905}$ $\times 5$	De.	2.94338	De.	2.94338
		$x$	8.82290-10		
(e) <b>.0973</b>	$\frac{28.98811-30}{9.66270-10}$   <b>3</b>				

$$\therefore x = .066512$$

*Remarks.* (I) The above form can of course be modified. Some computers, for instance, would perform the simpler multiplications and divisions mentally, and enter the results directly in the columns where used. The essential thing is not the use of a *particular* form, but the laying out of *some good form* in advance. It should provide places for the logarithms as they come from the table, for the modified logarithms, and for all necessary combinations.

(II) The negative characteristics above are so written that the subtracted integer is 10 or a multiple of 10. This system is used by computers, for reasons of uniformity and convenience in certain tables. (§ 149.) Evidently  $-1$  may be written either  $9 \dots -10$ , or  $19 \dots -20$ , or  $29 \dots -30$ , etc.

### EXERCISES

1. Prove  $\log \frac{a}{c} = \log a - \log c$ ;  $\log a^n = n \log a$ .
2. Prove  $\log \frac{ab^2}{c\sqrt[3]{d}} = \log a + 2 \log b - (\log c + \frac{1}{3} \log d)$ .

3. Estimate and compute to five figures :

$$(a) \frac{(3.6211)^9}{(86.21)^2}$$

$$(b) \frac{(9.2651)^4}{199870}$$

$$(c) \frac{(7.3)^5 \times .06162}{\sqrt{98\,020\,000}}$$

$$(d) \frac{5.086 \times (.008769)^3}{.98017 \times (.019842)^2}$$

$$(e) \sqrt[5]{\frac{.43 \times \sqrt{98421}}{\sqrt[3]{.80008}}}$$

$$(f) \sqrt{\frac{(.058)^3 \times 421.61 \times 8^6}{\sqrt{50} \times .045 \times (200.15)^{\frac{1}{2}}}}$$

4. The best elevation  $E$  in. for the outer rail of a railway curve of radius  $R$  ft. is given by  $E = 12 GV^2 / (32.2 R)$  where  $G$  feet is the gauge and  $V$  ft. per sec. the greatest speed used. Estimate and calculate  $E$  if  $G = 4.71$ ,  $V = 66$ , and  $R = 5730$ .

5. The volume of an oblate spheroid is  $V = \frac{4}{3} \pi R^2 r$ . Estimate and compute the volume of the earth if  $R = 3963.3$  and  $r = 3949.8$ .

6. An iron casting consists of a cone and hemisphere united, the flat side of the latter coinciding with the base of the cone. If the common radius is 9.8 ft. and the height of the conical part is 3.88 ft., find the total volume and surface area of the casting.

§ 142. **Calculations with Negative Numbers.** There is no "real" value of  $x$ , positive or negative, for which  $10^x$  is a negative number. That is, a negative number cannot have a "real" logarithm.

But calculations involving negative numbers can be made as follows: First decide by the elementary rules of signs whether the final result should be positive or negative. Then find its *numerical value* by logarithms, treating all the given numbers as positive.

$$\text{Ex. I. Calculate } x = \sqrt[3]{\frac{-3.14(-56.8)^2}{(-17.5)^5 \sqrt[7]{-100}}}$$

The combined effect of all these negative signs is to make  $x$  negative.

$$\therefore x = -\sqrt[3]{\frac{3.14(56.8)^2}{(17.5)^5 \sqrt[7]{100}}}$$

By logarithms the value of the radical itself is  $R = .14731$ .

$$\therefore x = -.14731.$$

*N.B.* It would be correct to write  $\log R = \frac{1}{2} [\log a + \dots]$ ; but not to write any similar equation for  $\log x$ , since  $x$  has no real logarithm.

**§ 143. Sums and Differences.** Suppose we have to make a calculation which calls for the addition of two quantities, as in

$$x = \sqrt{(1.1825)^{20} + \sqrt[3]{87556}}.$$

The quantities can be expressed as powers of 10, giving say

$$x = \sqrt{10^{1.45600} + 10^{1.64743}},$$

but they cannot be added by merely combining the exponents.

In what sort of calculation would you have to add the exponents or logarithms?

We must evidently look up the numbers which these two powers of 10 equal, and then add those numbers. And similarly in any other calculation involving a sum or difference, we must go from logarithms back to numbers before adding or subtracting.

In the example above the calculation could be arranged conveniently as follows, using  $U$  and  $V$  to denote the two quantities:

$U = (1.1825)^{20},$		$V = \sqrt[3]{87556},$		$x = \sqrt{U+V}$	
No.	Log	No.	Log	No.	Log
1.1825	.07280	87556	4.94229	$U+V$	1.86321
$(1.1825)^{20}$	1.45600	$\sqrt[3]{87556}$	1.64743	$\sqrt{U+V}$	.93160
$\therefore U = 28.576$		$\therefore V = 44.405$		$\therefore x = 8.5428$	
		$U+V = 72.981$			

Thus there are in reality three separate calculations: To find  $U$ , to find  $V$ , and to find  $x$ . The last cannot be started until we have finished the first two and have added the numbers  $U$  and  $V$ .

**§ 144. Short-cuts.** Sometimes by making a preliminary change in the form of the quantity to be computed we can save considerable work.

(A) *If some of the given numbers can be canceled or combined, mentally, fewer logarithms will need to be handled.*

*E.g.,  $A = \pi(25)^2$ , replace  $(25)^2$  by 625, and save one operation. Or, in  $V = \frac{1}{3}\pi r^2 h$ , cancel 3 into the value of  $h$ ; and one fewer logarithms will be needed.\**

(B) *By factoring, a sum or difference can sometimes be reduced to a product of known numbers.*

*E.g., the total area of a cylinder,  $A = 2\pi r^2 + 2\pi r h$ , may be written  $A = 2\pi r(r+h)$ . If given  $r = 113.4$  and  $h = 246.6$  we have  $r+h = 360$ ; and multiplying by the factor 2:*

$$A = (113.4)(720)\pi.$$

The two separate calculations needed to find  $A$  from the first formula are thus replaced by one simple calculation.

Similarly, suppose we wish to find one leg  $a$  of a right triangle, having given the hypotenuse and other leg,  $c = 983.5$ ,  $b = 726.2$ .

Since  $a = \sqrt{(983.5)^2 - (726.2)^2}$ , the calculation apparently involves going from a logarithm back to the number three times in all. But the difference of two squares is factorable:  $c^2 - b^2 = (c+b)(c-b)$ . Here

$$c+b = 1709.7, \quad c-b = 257.3. \quad \therefore a = \sqrt{(1709.7)(257.3)}.$$

Thus  $a$  is very readily computed.

### EXERCISES

1. Estimate and compute to five significant figures:

$$(a) \sqrt{485.7^2 - 321.4^2}, \quad (b) [\sqrt{73.146} - 1.025^2]^{\frac{1}{2}}.$$

2. (a) Estimate and compute by logarithms  $(\sqrt{5} - \sqrt{4})^4$ .

(b) Calculate the same value by using tables of roots.

3. Find the minimum value of  $y = x^6 - 19x + 8$ .

\*  $\log \pi$ , being often used, should be memorized or inserted on the "300 page" of the tables.

4. Find the total area of a cylinder whose base radius is 79.5 cm. and whose height is 189.2 cm.

5. The hypotenuse and one leg of a right triangle are respectively 495.73 ft. and 312.45 ft. Find the other leg.

6. Find the angle of elevation of the sun when a tower 458.75 ft. tall casts a shadow 1278.9 ft. long on horizontal ground. Check by measurement.

7. Compute to five figures :

$$(a) \sqrt[3]{\frac{-.032963}{7.9626}},$$

$$(b) \sqrt[5]{\frac{(-268.94)^3}{\pi(-.048167)^2}}.$$

§ 145. **Compound Interest Formula.** When a sum of money is left at compound interest for a long time, the amount finally accumulated is rather tedious to calculate by elementary arithmetic. Business men generally use interest tables. But there are problems not readily solvable by the tables. It is well, therefore, to know a general formula, which can be used either to make ordinary calculations quickly or to solve new types of problems.

For simplicity consider first some particular rate of interest, say 6%. Then if the interest is figured annually, the amount accumulated at the end of any year will be 106% of the sum at the beginning of the year. In other words, the sum will be multiplied by 1.06 during each year.

If the original principal is  $P$ , the amount after one year will be  $P(1.06)$ ; after two years,  $P(1.06)^2$ ; after three years,  $P(1.06)^3$ ; and so on. The final amount after  $n$  years will be

$$A = P(1.06)^n. \quad (1)$$

If the interest is compounded semi-annually, the sum will gain 3% in each half-year, or be multiplied by 1.03. After  $n$  years the original principal will have been multiplied by this factor  $2n$  times in all, making

$$A = P(1.03)^{2n}.$$

**GENERAL FORMULA.** From these special cases it appears that the amount of any investment  $P$ , after  $n$  years, with interest at any annual rate  $r$  ( $r$  being a fractional value, as .06, say), compounded  $k$  times a year, will be

$$A = P \left( 1 + \frac{r}{k} \right)^{kn}. \quad (2)$$

This inference is easily proved correct.

*Proof:* Let  $S$  be the sum accumulated at the beginning of any interest period. Then the interest gained during the period (one  $k$ -th of a year) will be  $rS/k$ ; and the amount at the end of the period will be  $S + rS/k$ , or  $S(1 + r/k)$ . Thus the sum will be multiplied by  $(1 + r/k)$  during each period; and there are  $kn$  periods in  $n$  years. Hence we have (2).

*Remarks.* (I) Formula (2) should be memorized carefully, as it covers all cases. For instance, if the interest is compounded annually, simply put  $k = 1$ , getting  $A = P(1 + r)^n$ , like (1) above.

(II) The formula is strictly correct, however, only at the *ends* of the interest periods, *i.e.*, for *integral* values of  $kn$ . To find  $A$  after  $10\frac{3}{4}$  periods, say, the exact method would be to find  $A$  after 10 periods, and then add simple interest for three fourths of a period. But formula (2) would give a very approximate result by simply putting  $n = 10.75$ .

(III) When compounding semi-annually, at the rate of 6%, the amount after 1 yr. will be  $A = P(1.03)^2 = P(1.0609)$ . Thus, due to the frequent compounding, the *effective* rate of increase is 6.09%; 6% is merely the *nominal* rate used in figuring.

**§ 146. Typical Problems.** We can now solve various typical problems in compound interest by merely substituting the numerical values in formula (2), and using logarithms.

In each of the following examples, set up the formula and logarithmic scheme for yourself. Then compare with the work shown here in fine print.

**Ex. I.** What will be the amount after 20 years, on an original investment of \$2750 with interest at 5%, compounded quarterly?

Here  $P = 2750$ ,  $n = 20$ ,  $k = 4$ ,  $r/k = .05/4 = .0125$ .

$$\therefore A = 2750(1.0125)^{80}.$$

We have merely to add the logarithm of 2750 to 80 times the logarithm of 1.0125, and look up the number  $A$ . [*Ans.*, taking  $\log 1.0125$  as .005395,  $A = 7429$ .] Observe that it is best to reduce  $r/k$  to .0125 before substituting it in the formula.

**Ex. II.** How much must be invested now to yield \$5000 thirty years hence, interest being at  $3\frac{1}{2}\%$ , compounded annually?

Here  $A = 5000$ ,  $n = 30$ ,  $k = 1$ ,  $r/k = .035$ .

$$\therefore 5000 = P(1.035)^{30}, \quad \text{or} \quad P = 5000/(1.035)^{30}.$$

We have merely to subtract 30 times the logarithm of 1.035 from  $\log 5000$ , and look up the number  $P$ . [*Ans.*,  $P = 1781.40$ .]

**Ex. III.** At what rate of interest, compounded semi-annually, would an investment of \$1750 yield \$5000 after 20 years?

Here  $A = 5000$ ,  $P = 1750$ ,  $n = 20$ ,  $k = 2$ .

$$\therefore 5000 = 1750 \left(1 + \frac{r}{2}\right)^{40}.$$

Let the unknown quantity  $1 + r/2$  be denoted by  $x$ . Then

$$5000 = 1750 x^{40}, \quad \therefore x = \sqrt[40]{\frac{5000}{1750}}.$$

Subtracting  $\log 1750$  from  $\log 5000$  and dividing by 40, we find

$$\log x = .01140, \quad \text{whence} \quad x = 1.0266.$$

This is  $1 + r/2$ ; that is,  $1 + r/2 = 1.0266$ .

$$\therefore \frac{r}{2} = .0266, \quad r = .0532. \quad [\textit{Ans.}, 5.32\%.]$$

**Ex. IV.** In how many years would \$983.50 amount to \$3875 with interest at 7% compounded semi-annually?

Here  $A = 3875$ ,  $P = 983.5$ ,  $k = 2$ ,  $r/k = .07/2 = .035$ .

$$\therefore 3875 = 983.5(1.035)^{2n}.$$

There is no method in elementary algebra for solving an equation for an *unknown exponent*. This problem will be discussed in § 147.

## EXERCISES

In these exercises interest is to be compounded annually unless otherwise specified.

1. In 1626 the Dutch bought Manhattan Island for \$24. To how much would this amount in 1920 if it had been at 7% interest?

2. What sum, deposited now, would yield \$17500 thirty years hence, if interest is at 5%, compounded semi-annually?

3. At what rate of interest will any sum be quadrupled in 25 years? (Take any convenient sum, say \$1.)

[4.] Compute by logarithms  $\frac{.47712}{.02531}$ . Also see if you can solve the equation  $(1.06)^n = 3$  for  $n$ . Can you think of any interest problem which would require the solution of this equation?

5. Find how much must be invested now to yield \$2500, fifteen years hence, interest at 5%, compounded quarterly.

6. At what rate will \$600 yield \$2400 after 30 yr.?

7. At what rate will \$6000 amount to \$15000 in 20 years, compounding semi-annually?

8. At what rate will any sum double itself in 9 years?

9. What sum set aside when a boy is 1 year old would provide an education fund of \$2000 when he is 16, if 4% interest is obtained, compounded semi-annually?

10. Find the amount of \$100 after 1 year with interest at 8%, compounded quarterly. What percentage is actually gained during the year, due to the frequent compounding, — *i.e.*, what is the *effective* rate?

11. A building costing \$4000 must be rebuilt every 20 years. What sum set aside when the building is erected will provide for its perpetual replacement, if the cost remains constant and money is always worth 4%? (Hint: The sum must produce itself plus \$4000 in 20 yr.)

§ 147. Finding an Unknown Exponent. Suppose we wish to solve the equation

$$2^x = 25.$$

Since  $2^x$  and 25 are equal, their logarithms must be equal. But the logarithm of  $2^x$  equals  $x$  times  $\log 2$ :

$$\therefore x \log 2 = \log 25, \quad \text{or } x(.30103) = 1.39794.$$



That is,  $x$  multiplied by .30103 equals 1.39794; and hence to find  $x$  we must divide 1.39794 by .30103:

$$x = \frac{1.39794}{.30103} = 4.6439.$$

This result is evidently about right, since  $2^4 = 16$  and  $2^5 = 32$ .

Notice then that this new problem of solving for an unknown exponent calls for the *division of a logarithm by a logarithm*, — not a mere subtraction of logarithms.

But we could of course avoid this long division by looking up *further* logarithms, — just as if we had been given the fraction to calculate in the first place. Subtracting the logarithm of .30103 from the logarithm of 1.39794 would give  $\log x$ .

We can now return to Ex. IV, p. 211, and find  $n$  from the equation,

$$3875 = 983.5 (1.035)^{2n}.$$

Here  $\log 3875 = \log 983.5 + 2n \log 1.035$ .

By tables:  $3.58827 = 2.99277 + 2n(.01494)$ .

Transposing 2.99277, and simplifying the coefficient of  $n$ :

$$.59550 = n (.02988).$$

By division:  $n = \frac{.59550}{.02988} = 19.93$ .

(We could avoid division by looking up further logarithms.)

It would be useless to calculate  $n$  more accurately, since the interest formula is exact only at the ends of interest periods.

**§ 148. Depreciation.** In any business it is necessary to allow for depreciation in the value of buildings, machinery, etc., due to wear which cannot be made good by current repairs.

For simplicity it is commonly figured that the value will decrease by a certain fixed sum during each year, until finally reduced to the mere "scrap value." But for some kinds of property it is more accurate to figure the loss during each year as a certain constant fraction of the value at the beginning of that year.

Ex. I. An automobile costing \$2000 loses each year 30% of its value at the beginning of that year. What will be its value after 5 years?

At the end of each year the value is 70%, or .7, of the value at the beginning of the year. Multiplying by .7 each year, we get the final value:

$$V = 2000(.7)^5 = 721.40.$$

*Remark.* If 15% were deducted every half-year, this would be "figuring the depreciation semi-annually at the yearly rate of 30%." After each half-year the current value would be multiplied by .85, and after each year by  $(.85)^2$ .

In general, if depreciation is figured  $k$  times a year at any nominal annual rate  $r$ , the value after  $n$  years would be

$$V = P \left( 1 - \frac{r}{k} \right)^{kn}. \quad (3)$$

### EXERCISES

1. Solve for  $x$ :  $2^x = 5$ ,  $3^x = 11$ ,  $4^x = 100$ .
2. In how many years would
  - (a) \$50,000 amount to \$80,000 at 5%, compounded quarterly?
  - (b) Any sum quadruple itself, at 5%, compounded semi-annually?
  - (c) \$1250 amount to \$2250, at  $4\frac{1}{2}$ %, compounded quarterly?
  - (d) \$3250 amount to \$8000, at 6%, compounded quarterly?
  - (e) Any sum be doubled, at 4%, compounded semi-annually?
3. An investment of \$75,000 depreciates so as to lose in each year 3% of its current value. What will it be worth after 30 years?
4. The same as Ex. 3 if the rate is 5% and the original value \$200,000.
5. If depreciation is figured semi-annually at the nominal annual rate of 20%, what is the actual rate of depreciation per year? (See *Remark* above; also (III), p. 210.)

**§ 149. Logarithms of Trigonometric Functions.** In solving a triangle, we can use logarithms to perform the multiplications and divisions. To make this very convenient, there are special tables from which we can read directly the logarithm of each sine, cosine, etc., which is used, *without first looking up the function itself*. Part of a typical page is shown here.

## 12° — LOGS OF TRIGONOMETRIC FUNCTIONS

'	<i>L sin</i>	<i>d</i>	<i>L tan</i>	<i>cd</i>	<i>L ctn</i>	<i>L cos</i>	<i>d</i>	
0	9.31 788		9.32 747		0.67 253	9.99 040		60
1	9.31 847	59	9.32 810	63	0.67 190	9.99 038	2	59
—								—
18	9.32 844		9.33 853		0.66 147	9.98 991		42
19	9.32 902	58	9.33 913	60	0.66 087	9.98 989	2	41
—								—
59	9.35 154		9.36 279		0.63 721	9.98 875		1
60	9.35 209	55	9.36 336	57	0.63 664	9.98 872	3	0
	<i>L cos</i>	<i>d</i>	<i>L ctn</i>	<i>cd</i>	<i>L tan</i>	<i>L sin</i>	<i>d</i>	'

PRO. PTS.

60 58

2 12 11.6

3 18 17.4

4 24 23.2

5 30 29.0

6 36 34.8

7 42 40.6

8 48 46.4

9 54 52.2

## LOGS OF TRIGONOMETRIC FUNCTIONS — 77°

*Explanation.* With every logarithm in the table  $-10$  is to be understood, except in the third main column headed *L ctn*. *E.g.*, the first entry opposite  $18'$  means that

$$\log \sin 12^\circ 18' = 9.32844 - 10 = .32844 - 1.*$$

The labels at the bottom and minutes at the right indicate that this same value  $9.32844 - 10$  is  $\log \cos 77^\circ 42'$ .

Interpolations can be made rapidly by using the marginal tables of proportional parts, and the narrow columns marked "*d*" or "*cd*" which give the differences between successive logarithms.

**Ex. I.** Find  $\log \sin 12^\circ 18'.7$ . Between  $18'$  and  $19'$ , the value increases by 58. By the marginal table seven tenths of 58 is 40.6. Adding 41 to  $\log \sin 12^\circ 18'$ , we find  $9.32885 - 10$ .

**Ex. II.** Find  $\log \text{ctn } 12^\circ 18'.1$ . Here  $d = 60$ , and the value is *decreasing*. From  $\log \text{ctn } 12^\circ 18'$  we *subtract* one tenth of 60 (which being obviously 6, is not shown in the marginal table), and get 0.66141. A

\* Without these tables we should have to look up  $\sin 12^\circ 18'$  ( $= .21303$ ), and then look up  $\log .21303$  ( $.32844 - 1$ ). Two interpolations would be necessary in finding  $\log \sin 12^\circ 18'.4$ .

common-sense check is that this result lies between the values given for 18' and 19', and is much nearer the former.

Ex. III. Given  $\log \tan A = 0.66130$ , clearly  $A = 77^\circ 41' +$ . Here  $d = 60$ , and the given logarithm exceeds  $\log \tan 77^\circ 41'$  by 43. The question is, how many tenths of a minute will make a difference of 43 in the logarithm? The marginal table headed 60 says .7 approximately. (More accurately, 43 is  $.72 \times 60$ .) Thus  $A = 77^\circ 41'.7$  approx.

Ex. IV. Given  $\log \cos B = 9.32852 - 10$ . Clearly  $B = 77^\circ 41' +$ . Opposite 41' we read 9.32902, from which the given logarithm differs by 50. The marginal table headed 58 shows 50 opposite .9. Hence  $B = 77^\circ 41'.9$ .

*N.B.* We always work from the value shown opposite the *smaller angle*, whether this value is the smaller logarithm or not, — for the simple reason that angles are written in the form  $77^\circ 41'.9$  rather than  $77^\circ 42' - .1'$ !

§ 150. **Logarithmic Solution of Triangles.** Typical examples.

Ex. I. Given  $b = 750$ ,  $A = 40^\circ$ ,  $C = 80^\circ$ ; find  $a$ ,  $c$ ,  $B$ . (Estimate, using a protractor:  $a = 550$ ,  $c = 850$ ,  $B = 60^\circ$ .)

$$\text{Sine law: } \frac{a}{\sin 40^\circ} = \frac{750}{\sin 60^\circ} = \frac{c}{\sin 80^\circ}$$

We subtract  $\log \sin 60^\circ$  from  $\log 750$ , and then add  $\log \sin 40^\circ$  or  $\log \sin 80^\circ$ .

No.	Log	No.	Log
750	2.87506	frac.	2.93753
$\sin 60^\circ$	9.93753	$\sin 80^\circ$	9.99335
frac.	2.93753	$c$	2.93088
$\sin 40^\circ$	9.80807		$a = 556.67$
$a$	2.74560		$c = 852.86$

Ex. II. Given  $b = 21.75$ ,  $c = 24.75$ ,  $A = 40^\circ$ ; find  $a$ ,  $B$ ,  $C$ . (Graphical estimate:  $B = 60^\circ$ ,  $C = 80^\circ$ ,  $a = 16$ .)

$$\text{Cosine law: } a^2 = (21.75)^2 + (24.75)^2 - 2(21.75)(24.75) \cos 40^\circ.$$

The addition and subtraction can be performed only after going back from logarithms to numbers. Thus the cosine law is inconvenient for logarithmic work. Better formulas are derived in §§ 151–153.

Ex. III. Given  $a = .8273$ ,  $b = .9999$ ,  $C = 90^\circ$ ; find  $B$ . This is a right triangle and *should be solved as such*:

$$\tan B = \frac{b}{a} = \frac{.9999}{.8273}$$

Subtract  $\log a$  from  $\log b$ , and look up  $B$  directly. [*Ans.*,  $B = 50^\circ 23'.8$ .]

## EXERCISES \*

1. Look up the logarithms of  $\sin 14^\circ 27'$ ,  $\sin 78^\circ 22'.4$ ,  $\cos 56^\circ 53'.7$ ,  $\tan 23^\circ 13'.8$ ,  $\cotn 84^\circ 53'.7$ . (Check the first by looking up the sine itself and then its logarithm.)

2. Look up  $\angle A$  if  $\log \sin A = 8.76966 - 10$ ;  $\log \cos A = 9.92379 - 10$ ;  $\log \tan A = 1.27960$ ;  $\log \cotn A = 0.46235$ .

3. The hypotenuse and one leg of a right triangle are 74.157 and 50.063 inches. Solve the triangle, finding the third side by means of an angle.

4. In Ex. 3, check in part by finding the third side directly from the given sides.

5. Solve graphically and by tables the triangle in which  $a = 738.1$ ,  $B = 78^\circ 14' 42''$ ,  $C = 54^\circ 26'$ .

6. The gravitational acceleration  $g$  (cm./sec.<sup>2</sup>) is given for any latitude  $L$  by the equation  $g = 977.989 [1 + .0052 (\sin L)^2]$ . Find  $g$  for the latitude  $L = 45^\circ 29'$ .

7. Solve each of the following oblique triangles for the missing parts:

	$a$	$b$	$c$	$A$	$B$	$C$
i	368.42			$62^\circ 15'$	$93^\circ 42'$	
ii		.038627		42 38	2 13	
iii			28.935	16 41	32 19	
iv	1280.5				58 6.2	$48^\circ 27'.5$
v		47.198		75 12.8		5 8 .3

8. Find the radius of the circle inscribed in a regular decagon whose perimeter is 286.5 ft.

9. What is the elevation angle of the sun when a pole 106.5 ft. high casts a shadow 286.9 ft. long on level ground?

\* For further triangles to solve see pp. 227, 231.

§ 151. **Area of a Triangle.** To find the area of a triangle we may first solve for some one of its altitudes by dropping a perpendicular, and then multiply by one half the corresponding base.

Or if the three sides happen to be known, we can find the area immediately by using a formula from geometry: \*

$$S = \sqrt{h(h-a)(h-b)(h-c)}, \quad \checkmark \quad (4)$$

where  $S$  denotes the area, and  $h$  one half the perimeter, *i.e.*,

$$h = \frac{1}{2}(a+b+c). \quad (5)$$

*Remark.* From (4) we can also derive a formula for the radius  $r$  of the inscribed circle. For by Fig. 74:

$$S = \frac{1}{2} ar + \frac{1}{2} br + \frac{1}{2} cr = \frac{1}{2}(a+b+c)r \quad \checkmark$$

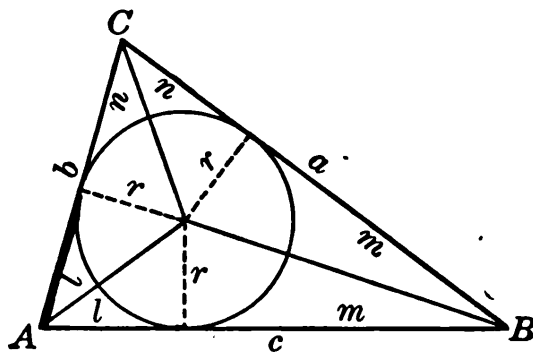

FIG. 74.

That is,  $S = hr$ , or  $r = S/h$ . Using here the value of  $S$  in (4) above and putting our divisor  $h$  also under the radical, we get, on simplifying:

$$r = \sqrt{\frac{(h-a)(h-b)(h-c)}{h}}. \quad \checkmark \quad (6)$$

§ 152. **Half-Angles.** Since the center of the inscribed circle lies on the bisector of each angle, we have from Fig. 74:

$$\tan\left(\frac{1}{2}A\right) = \frac{r}{l}, \quad \tan\left(\frac{1}{2}B\right) = \frac{r}{m}, \quad \text{etc.} \quad (7)$$

But  $l+m+n$  is one half the perimeter, or  $h$ . (§ 151.)

$$\therefore l = h - (m+n) = h - a. \quad (8)$$

\* If this formula is unfamiliar, see p. 489 of the Appendix for its derivation.

Similarly  $m = h - b$ , and  $n = h - c$ .

Substituting in (7) above :

$$\tan \left(\frac{1}{2} A\right) = \frac{r}{h-a}, \quad \tan \left(\frac{1}{2} B\right) = \frac{r}{h-b}, \text{ etc.} \quad (9)$$

where  $r$  denotes the radical quantity in (6) above.

Formulas (9) can be used instead of the cosine law to solve a triangle when the three sides are given. They are well suited to logarithmic methods.

Ex. I. Find the angles and area, of a triangle in which  $a = 275.8$ ,  $b = 361.4$ ,  $c = 446.2$ .

The formulas are (9) above, together with

$$h = \frac{a+b+c}{2}, \quad r = \sqrt{\frac{(h-a)(h-b)(h-c)}{h}}, \quad S = hr.$$

(What steps are needed to find  $\log r$ ?  $\log \tan \frac{1}{2} A$ ?  $\log S$ ?)

No.	Log	No.	Log	
$h = 541.7$		$r$	1.96348	
$h - a = 265.9$	2.42472	$h - a$	2.42472	$\frac{1}{2} A = 19^\circ 4' 22''$
$h - b = 180.3$	2.25600	$\tan \left(\frac{1}{2} A\right)$	9.53876 - 10	$A = 38 \quad 8 \quad 44$
$h - c = 95.5$	1.98000	$r$	1.96348	$\frac{1}{2} B = 27 \quad 1 \quad 0$
(Check*)	6.66072	$h - b$	2.25600	$B = 54 \quad 2 \quad 0$
$h = 541.7$	2.73376	$\tan \left(\frac{1}{2} B\right)$	9.70748 - 10	$\frac{1}{2} C = 43 \quad 54 \quad 38$
	3.92696	$r$	1.96348	$C = 87 \quad 49 \quad 16$
$r$	1.96348	$h - c$	1.98000	
$h$	2.73376	$\tan \left(\frac{1}{2} C\right)$	9.98348 - 10	
$S$	4.69724			

Area,  $S = 49801$ .

Final check :  $A + B + C = 180^\circ$ .

The final check is satisfied closely enough for five-place tables if the discrepancy between  $180^\circ$  and  $A + B + C$  is less than  $6''$ .

To find  $C$  from  $A$  and  $B$  by the relation  $A + B + C = 180^\circ$  would be undesirable, as it would leave us no simple check.

\* A check on  $h - a$ ,  $h - b$ , and  $h - c$ , is that their sum,  $3h - (a + b + c)$ , must equal  $h$ . (Why?)

## EXERCISES

1. Find the angles of a triangle in which  $a=63.89$ ,  $b=138.24$ ,  $c=121.15$ . Find all independently, and check.

2. Derive the formula  $\tan \frac{1}{2} B = r/(h-b)$ .

3. In each of the triangles whose sides are given below find the three angles, independently, and check. Also find the area.

	$a$	$b$	$c$		$a$	$b$	$c$
i	289.6	462.5	378.1	iv	.9628	.4315	.6782
ii	514.7	625.8	981.4	v	.00681	.00419	.00745
iii	29.87	19.51	16.23	vi	12980	15642	18326

4. A ladder 36.45 ft. long is set 15.75 ft. from the foot of a sloping buttress, and reaches 30.38 ft. up its face. Find the inclination of that face.

5. If two forces of 638.9 lb. and 1211.5 lb. have a resultant of 1382.4 lb., what is the angle between them?

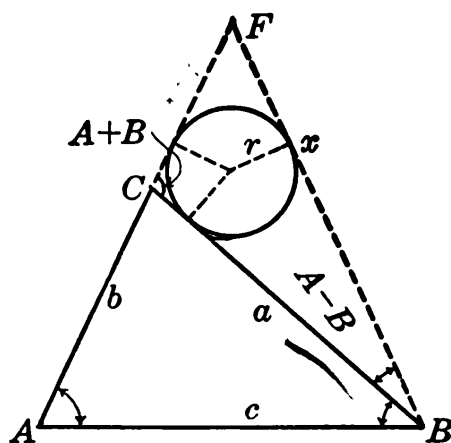

FIG. 75.

§ 153. **Tangent Law.** On any side  $c$  of a given triangle, as base, construct an isosceles triangle  $ABF$  by extending the shorter of the other two sides, say  $b$ , and making  $\angle ABF = \angle A$ . (Fig. 75.)

Then in  $\triangle BCF$  two of the angles are  $A+B$  and  $A-B$ , and the opposite sides are, say,  $x$  and  $x-b$ . By § 152,

$$\tan \frac{1}{2}(A-B) = \frac{r}{h-(x-b)} \quad \tan \frac{1}{2}(A+B) = \frac{r}{h-x}, \quad (10)$$

where  $r$  is the radius of the circle inscribed in  $\triangle BCF$ , and

$$h = \frac{1}{2}(a+x+\overline{x-b}) = x + \frac{1}{2}(a-b). \\ \therefore h-x = \frac{1}{2}(a-b), \quad h-(x+b) = \frac{1}{2}(a+b).$$



From (10), by dividing and substituting these values :

$$\frac{\tan \frac{1}{2}(A-B)}{\tan \frac{1}{2}(A+B)} = \frac{h-x}{h-(x-b)} = \frac{a-b}{a+b}. \quad (11)$$

Observe what this means for the original triangle  $ABC$  :

*The tangent of half the difference of any two angles of a triangle is to the tangent of half the sum as the difference of the opposite sides is to the sum of those sides.\**

This "tangent law" is adapted to the logarithmic solution of a triangle, when two sides and their included angle are given, say  $a$ ,  $b$ , and  $C$ . For the sum  $\frac{1}{2}(A+B)$  is known, and by finding  $\frac{1}{2}(A-B)$  from (11), we can combine to obtain  $A$  and  $B$  separately.†

Ex. I. If  $a=37.485$ ,  $b=28.392$ ,  $C=40^\circ$ , find  $A$ ,  $B$ ,  $c$ .

$$a-b = 9.093$$

$$A+B = 180^\circ - 40^\circ$$

$$a+b = 65.877$$

$$\frac{1}{2}(A+B) = 70^\circ$$

$$\frac{\tan \frac{1}{2}(A-B)}{\tan 70^\circ} = \frac{9.093}{65.877}$$

(How would  $\tan \frac{1}{2}(A-B)$  be found from this last equation without logarithms? How, therefore, when using logarithms?)

No.	Log	
9.093	0.95871	$\frac{1}{2}(A+B) = 70^\circ$ <hr/> $\frac{1}{2}(A-B) = 20^\circ 46' 6''$ $A = 90^\circ 46' 6''$ $B = 49 \quad 13 \quad 54$
$\tan 70^\circ$	0.43893	
Product	1.39764	
65.877	1.81873	
$\tan \frac{1}{2}(A-B)$	9.57891	

To find  $c$  use the Sine Law:  $\frac{c}{\sin C} = \frac{b}{\sin B}$ .

\* In Fig. 75 we took  $\angle A$  as acute. If it happens to be obtuse, simply produce  $b$  and  $BF$  backwards to meet at some point  $F'$ . Two angles in  $\triangle BCF'$  will be the supplements of  $A-B$  and  $A+B$ . Halving these angles will give the complements of  $\frac{1}{2}(A-B)$  and  $\frac{1}{2}(A+B)$ . The proof can then be carried through as above, if we recall that the tangent of the complement of  $\frac{1}{2}(A-B)$  is  $\cot \frac{1}{2}(A-B)$  or  $1/\tan \frac{1}{2}(A-B)$ ; etc.

† The method of § 118, Ex. I, may also be used.

*Remark.* Merely adding the three angles would give *no check whatever* upon the logarithmic work done in finding  $A$  and  $B$ . Suppose, for example, that we had erroneously found in the case above:

$$\frac{1}{2}(A - B) = 10^\circ, \quad \therefore A = 80^\circ, \quad B = 60^\circ.$$

Adding:  $A + B + C = 180^\circ$ , which does not show the error.

*Why* does this fail to detect the error? [Where did we get the value of  $\frac{1}{2}(A + B)$ ?] What *formula* could be used as a real check upon  $A$  and  $B$ ?

### EXERCISES

1. Given  $C = 124^\circ 34'$ ,  $a = 52.8$ ,  $b = 25.2$ . Find the other parts.
2. Given  $a = 41.003$ ,  $b = 48.718$ ,  $C = 68^\circ 33' 58''$ . Find the other parts.
3. (a), (b). Find the areas of the triangles in Ex. 1, 2.
4. Find the missing parts of the following triangles; and also the areas.

	$a$	$b$	$c$	$A$	$B$	$C$
i	1285.9	2684.5				$42^\circ 38'$
ii	.9248	.6983				98 15.2
iii	62.875		39.487		$20^\circ 15'.8$	
iv	4.1635		5.2940		112 38	
v		9.4683	5.6291	$51^\circ 16'.3$		
vi		96.285	112.34	106 28		

**§ 154. Other Bases.** The logarithms which we have been using are possible because of the fact that every number is some power of 10. But it is equally true that every number is some power of 2, or of 7, or of any other positive number, except 1. Hence it is possible to have other systems of logarithms, based upon powers of 2, or 7, etc.

For instance, if

$$5 = 2^{2.32193},$$

the exponent 2.32193 is called "the logarithm of 5 to the base 2," written  $\log_2 5$ .

And in general, the logarithm of any number to any base is *the exponent of the power to which the base must be raised to produce the number.*

The “common logarithms,” to the base 10, which we have been using, are by far the best for most numerical calculations, — because of the fact that moving a decimal point in a number merely adds some integer to the characteristic. Only one other base is very generally used for any purpose; this will be discussed in § 166. But it is well to be familiar with the following general principles.

No matter what base  $B$  we may be using :

$$\log 1 = 0, \quad \text{and} \quad \log B = 1. \quad (12)$$

$$\text{For} \quad 1 = B^0, \quad \text{and} \quad B = B^1.$$

The logarithm of any positive number to any base is easily found with the help of common logarithms. For instance, suppose we want  $\log_2 25$ . We simply let this equal  $x$ , and write the equivalent exponential equation :

$$\log_2 25 = x, \quad 25 = 2^x.$$

Solving the latter equation as in § 147, we find  $x = 4.6439$ .

**§ 155. Slide Rule.** Logarithmic calculations can be made mechanically by means of a “slide rule.” This has a fixed scale  $F$  and a sliding scale  $S$  (roughly illustrated in Fig. 76), each so ruled that the distance from 1 to any other number  $x$  is equal to  $\log x$ .

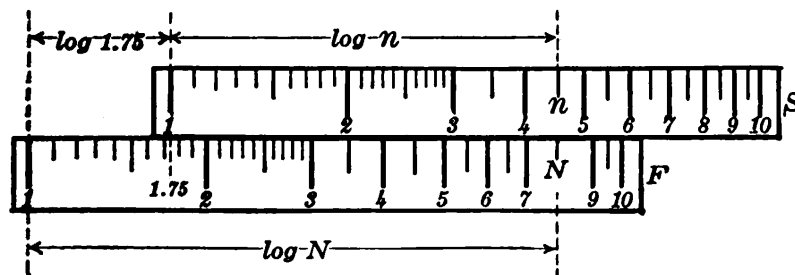

FIG. 76.

When  $S$  is moved over to the position shown, its 1 being opposite 1.75 on  $F$ , every number ( $n$ ) on  $S$  will have moved a distance equal to

log 1.75 and hence will be opposite some number  $N$  on  $F$  whose logarithm is the sum of log 1.75 and log  $n$ . This number  $N$  must be the product of 1.75 and  $n$ .

Thus to multiply any number  $n$  by 1.75, we merely set the slide as in Fig. 76 and then read off the number on  $F$  opposite  $n$ . (Observe how this works for the simple product  $2 \times 1.75 = 3.5$ .)

Similarly for other multiplications: moving  $S$  mechanically adds logarithms. Divisions may also be performed, square

roots extracted, etc. Results accurate to two or three places can be obtained very fast. Full directions are given in handbooks supplied with the rule.

### § 156. Nomographic Charts.

In recent years much use has been made of nomographs, — *i.e.*, charts of lines ruled with number scales in such a way that various calculations can be made by merely laying a straight-edge across the scales.

Fig. 77 illustrates this. The cost of an automobile tire per mile traveled can be read off from scale  $B$  by laying a ruler or stretching a thread across from the original cost on scale  $A$  to the

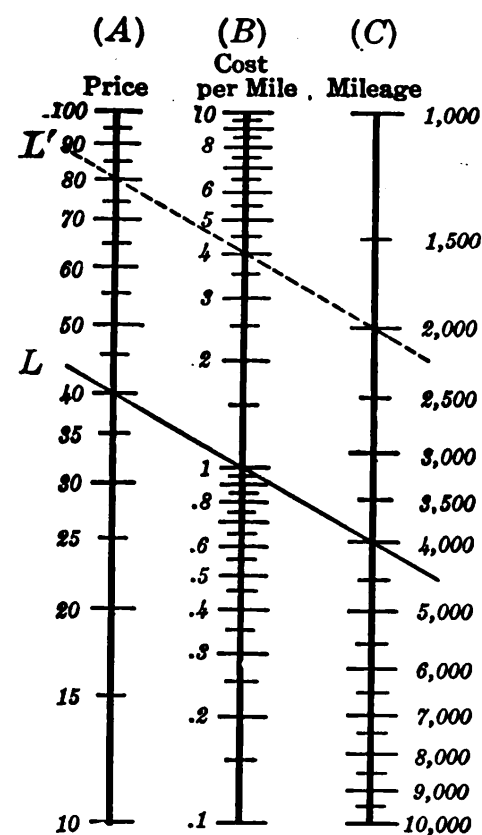

FIG. 77.

number of miles realized, as shown on scale  $C$ .

*Explanation.* The scales here are logarithmic, the unit on  $B$  being half as long as on  $A$  or  $C$ . Any line  $L$  through 1 on  $B$  passes through equal numbers on  $A$  and  $C$ , — as it obviously should.

Raising  $L$  a distance equal to log 2 on  $A$  would bring it to a parallel position  $L'$ , passing through a number on  $A$  twice as large as formerly, — just as with a slide rule. On  $C$ ,  $L'$  will pass through a number half the

former value. Hence the ratio  $A/C$  will be four times as great as for line  $L$ , — *i.e.*, it equals 4. But the distance  $L'$  was raised, viz.,  $\log 2$  on scale  $A$  equals  $\log 4$  on scale  $B$ ; hence  $L'$  will cross  $B$  at 4, as it should to give the value of  $A/C$ .

But every line which could be laid across the scales would be some line  $L$ , raised or lowered; and by a similar argument must cross  $B$  at the right point.

**§ 157. Summary of Chapter VI.** In § 135 we have already summarized the definition and basic properties of common logarithms. We have since observed that any positive number (except 1) could serve as the base of a system of logarithms.

Logarithms follow the laws of exponents, and are therefore specially adapted to the calculation of products, quotients, powers, roots, and unknown exponents. They are continually used in scientific work of many kinds, as is also their mechanical substitute, the slide rule.

Sums and differences can sometimes be factored into products. Otherwise we must go from logarithms back to numbers before adding or subtracting. For this reason, the cosine law is ill-adapted to the solution of triangles where large numbers are involved. It may then be replaced by the Half-angle Formulas or the Law of Tangents.

Calculations involving negative numbers can be made by taking separate account of the combined effect of the minus signs. (In Chapter XIII we shall define the logarithm of a negative number.)

The tremendous power of the logarithmic method is hard to realize. Notice how easily we could compute a root such as  $\sqrt[2011]{3.1416 \times 10^{817}}$ , and how fearfully complicated such a calculation would be by pure arithmetic.

Logarithms were invented by Lord Napier, a Scotchman, who published the first tables in 1614. These were not to the base 10, but to a base closely related to the one discussed later in § 166.

Our more convenient tables, to the base 10, were calculated soon

afterward by Henry Briggs, an Englishman, and Adrian Vlacq, a Hollander, who unselfishly gave up several years to the tedious work.

## EXERCISES

1. Calculate correct to five significant figures:

- |  |  |
|--|--|
| (a) $\sqrt{\frac{.047963}{8.5125}}$ ,  | (b) $\frac{73.452}{.08754(.4564)(4.6592)}$ ,   |
| (c) $\sqrt{\frac{.58642(30.007)}{.000099128}}$ ,                                       | (d) $\sqrt[3]{\frac{693.02(-.04692)}{.038412(-569.8)^2}}$ ,                          |
| (e) $\sqrt{(74.157)^2 - (50.063)^2}$ ,   | (f) $\sqrt[6]{\frac{3.19 \times \sqrt[5]{9.2614}}{(.519)^2 \times \sqrt{117.38}}}$ , |
| (g) $\frac{(.2685)^{20} \times (-47.168)^5}{\sqrt[7]{.001} \times (.096416)^2}$ ,      |  |
| (h) $\left(\frac{-31.632}{428.95}\right)^{17} \times (18.951)^{11} \times (.1)^{13}$ , |  |
| (i) $\frac{2\sqrt[3]{.6} \sqrt[4]{.002} \sqrt[5]{442.6}}{81 (.7)^3 (3.4562)}$ ,        | (j) $\frac{13261(.78465)^4 \sqrt[3]{.0834}}{2.7651 \times \sqrt{.0063524}}$ ,        |
| (k) $\left(\frac{\sqrt{5}}{.79} - \sqrt[3]{1.07}\right)^{\frac{2}{3}}$ ,               | (l) $\sqrt{48900\pi + (489)^2}$ .  |

2. Find the amount of \$2000 after 20 yr. with interest at 5%, compounded annually.

3. What principal will yield \$15000 in 25 years, if interest is at 6%, compounded annually?

4. At what rate of interest, compounded semi-annually, will \$12250 yield \$37500 in 25 years?

5. In how many years will \$12250 amount to \$37500 if interest is at 5%, compounded quarterly?

6. Find  $H$  from the two equations:

$$MH = \frac{\pi^2 I}{T^2}, \quad \frac{M}{H} = \frac{r^3 d}{8 l} \left( \frac{\pi}{\pi - a} \right),$$

if  $I = 516.38$ ,  $T = 6.4$ ,  $r = 100$ ,  $d = 6.07$ ,  $l = 237$ , and  $a = .002$ .

*Solve the following by trigonometry, and check by drawing to scale and measuring the required distances or angles.*

7. A tree is broken by the wind. Its top strikes the ground 45 ft. from the foot of the tree, and makes an angle of  $35^\circ 56'$  with the ground. Find the original height.

8. From one bank of a river the angle of elevation of a tree on the other bank directly opposite is  $27^\circ$ . From a point 129.5 ft. farther away horizontally in a direct line its angle of elevation is  $20^\circ 40'$ . Find the width of the river.

9. A boat, viewed from the top and from the bottom of a lighthouse 92 ft. tall, had depression angles of  $16^\circ 20'$  and  $10^\circ 50'$  respectively. Find the height of the rock on which the lighthouse stands.

10. A monument is 133 ft. high, and stands at the top of a hill. At a point 276 ft. down the hill the monument subtends an angle of  $12^\circ 3'$ . Find the distance from this point to the top of the monument.

11. The sides of a triangle are 196.87, 281.45, and 358.16. Find the length of the perpendicular from the largest angle upon the opposite side.

12. A triangular lot has an area of 527.75 sq. yd., and two of its sides measure 169.8 ft. and 67.4 ft. Find its perimeter. (Two solutions.)

13. A cliff rises vertically 250.92 ft. above sea-level. From its top the angles of depression of two ships are  $16^\circ 21'$  and  $14^\circ 18'$ . At the bottom of the cliff the angle subtended by the distance between the ships is  $127^\circ 28'$ . How far apart are the ships?

§ 158. **Looking Back.** Let us now recall in brief outline the work of the course up to this point.

We began by noting that the fundamental problem of science, whether in studying the physical world or the social and economic world, is to determine the relations between varying quantities, — in other words, to ascertain *precisely how any one quantity will vary with any other on which it depends*. And our aim all along has been to find methods of dealing with this problem, — how to calculate rates of increase, maximum and minimum values, etc. Incidentally we have tried to get some idea of how these methods are used in the practical affairs of daily life.

We first saw that approximate results can be obtained by graphical methods, and that we can always fall back upon these methods as a last resort.

Upon attempting to calculate instantaneous rates exactly, we were led to differentiation. To reverse the rate-problem

and calculate the size of a growing quantity, we had to take up integration.

Various integrations and numerical calculations which we could not carry out showed the necessity of becoming familiar with further types of functions, especially trigonometric functions and logarithms.

We have now done this, in a measure, and are ready to proceed with the main problem and make further applications of differentiation and integration in the study of varying quantities.

### EXERCISES FOR REVIEW

#### Chapter I \*

1. The average number of hours of artificial light used daily in a certain city in the various months is shown in Table I. Plot the graph.

TABLE I

Mo.	Hrs.	Mo.	Hrs.	Mo.	Hrs.
Jan.	6.53	May	2.95	Sept.	4.00
Feb.	5.38	June	2.55	Oct.	4.90
Mar.	4.10	July	2.60	Nov.	6.18
April	3.48	Aug.	3.15	Dec.	6.85

2. A concrete pedestal has horizontal sectional areas ( $A$  sq. ft.) which vary with the distance ( $x$  ft.) above the ground, as in Table II. Find the rate at which  $A$  changes with  $x$  at  $x=6.4$ ; also the volume from  $x=4$  to  $x=16$ .

TABLE II

$x$	4	6	8	10	12	14	16
$A$	40	21.7	14.1	10.1	7.7	6.1	5.0

\* Further graphical problems are included in the miscellaneous set following.



3. Solve for  $x$  exactly or approximately:  
 (a)  $7x^2 - 19x + 4 = 0$ , (b)  $x^2 - 5x + 1 = 0$ .
4. If  $y$  varies as the square root of  $x$ , and  $y = 30$  when  $x = 4$ , express  $y$  in terms of  $x$ , and find  $y$  when  $x = 25$ .
5. Discover the formula satisfied by the values in this table:

$x$	2	8	17	29	44
$y$	4	8	14	22	32

### Chapter II

1. State accurately and fully what is meant by: (a) Instantaneous speed; (b) a tangent to any curve; (c) the area of a circle.
2. When is a variable  $v$  said to approach a constant  $c$  as its limit?
3. State accurately what is meant by saying: "This spiral bends faster and faster; just at this point it is bending at the rate of exactly  $2^\circ$  per inch."
4. State clearly what is meant by the weight of a cubic foot of air "at any height  $h$  ft." Evidently a cubic foot cannot all be at the same height.
5. Can you see any definite interpretation that can be given to this statement: "The amount of \$1, with 10% interest for 10 years, *compounded continuously*, would be \$2.718"? How could this amount be verified approximately?
6. If  $y = x^3 + 2x$ , and  $x$  increases by  $\Delta x$ ,  $y$  will increase by some amount  $\Delta y$ . If  $\Delta x \rightarrow 0$ , so must  $\Delta y$ . Could you tell what limit the fraction  $\Delta y/\Delta x$  approaches, merely from the fact that  $\Delta x$  and  $\Delta y$  are both approaching zero? (Work out the value of  $\Delta y$  in detail; find the limit of  $\Delta y/\Delta x$ .)

### Chapter III

1. Differentiate the function  $y = x^2$  by the  $\Delta$  process. Explain the meaning of each important step geometrically, and also from the standpoint of rates.
2. Explain graphically how it would be possible for  $f'(x)$  to have a large value (say 100) at some point, even if  $f(x)$  was everywhere small (say never more than .5 nor less than zero).
3. The quantity of heat ( $Q$  cal.) which 1 cu. ft. of water holds is a function of its temperature ( $T^\circ$ ). The instantaneous rate of increase of  $Q$  per degree is called the "specific heat," at the temperature in question. Write a familiar symbol expressing it.

4. Differentiate the function  $x^3+3x-12$  by the  $\Delta$  process. Show from the derivative that the given function can have only one real root.
5. Differentiate at sight:
- (a)  $y = \frac{1}{2}x^4 + .2x^2(10x-7) + 11x - 13\sqrt{x} + \sqrt{95}$ ,
- (b)  $y = 6\sqrt[3]{x} + 20 - 7/x + 5/\sqrt{x^3} - 125/4x^4$ ,
- (c)  $y = (x^4+7)^{100} + \frac{\sqrt{25-x^2}}{9} + \frac{60-x}{7} - \frac{3}{5(2-x^2)^3}$ .
6. Plot  $y = .1(x^3 - 15x + 2)$  from  $x = -4$  to  $x = 4$ . Locate exactly the maximum and minimum. Also find the exact slope and inclination of the tangent at the point of inflection.
7. An open rectangular tank is to contain 4000 cu. ft. Materials for the base cost 80¢ per sq. ft., and for the sides 60¢ per sq. ft. Find the lowest possible cost.
8. The volume of a balloon ( $V$  cu. ft.)  $t$  hours after sunrise was  $V = \frac{\pi}{3}(100\,000 + 80t^3 - 10t^4)$ . When was  $V$  increasing most rapidly? Approximately how much did  $V$  change from  $t = 3.98$  to  $t = 4.02$ ?
9. State briefly but clearly the *principles* used in Ex. 8.
10. If  $y = 10x^2$ , show by the  $\Delta$  process that  $\frac{dy}{dt} = 20x \frac{dx}{dt}$ .
11. A cube grows. When are the volume and area increasing at the same rate numerically? Approximately how much must the edge then increase to add .06 unit to the volume?
12. If the volume of a spherical balloon varies thus with the absolute temperature:  $V = 40,000 T^{\frac{3}{2}}$ , and if  $T$  is rising at the rate of  $2^\circ$  per min., how fast is  $V$  increasing when  $T = 300$ ? Also, how fast is the radius increasing?

### Chapter IV

1. Integrate, and check your answer by differentiation:
- $$(x^4 - 7x^3 + x^2/5 + 15x/2 - \sqrt{x} - 7 + 2/x^2 - 5x^3)dx.$$
2. A bullet was fired straight up from an airplane 2000 ft. high with an initial speed of 1600 ft./sec. Find its height and speed 10 sec. later; also its greatest height; also when it struck the ground and with what speed.
3. Find the area under the curve  $y = x + 1/x^2$  from  $x = 1$  to  $x = 10$ .
4. The force used in starting an object varied thus:  $F = 120t^2 - t^3$ . Find the momentum imparted in the first 10 seconds.
5. Find the pressure down to a depth of 10 ft. against a vertical dam whose width varies thus:  $w = 120 - x^2$ .

6. The "total utility" ( $u$ ) and "marginal utility" ( $m$ ) of any quantity ( $x$ ) of a commodity, — as defined in Economics, — have this relation:  $du/dx = m$ . If we had a graph exhibiting  $m$  as a function of  $x$ , what would represent  $u$ ? Why?

7. A solid is hollowed out in the middle, so that every horizontal cross-section is a ring between two concentric circles, whose radii ( $r$  in. and  $R$  in.) vary thus with the distance ( $x$  in.) below the highest point:  $r = \sqrt{6x - x^2}$  and  $R = \sqrt{8x - x^2}$ . Calculate the volume, from  $x = 0$  to  $x = 3$ .

8. In Ex. 7, if the weight of the material ( $w$  lb.) per cu. in. varies with  $x$  (say  $w = .06x$ ), devise some method for calculating exactly the total weight of the solid from  $x = 0$  to  $x = 3$ .

### Chapter V

1. Given  $\cot A = \frac{4}{15}$ , find the sine, cosine, and tangent, without tables.

2. Find the slope and the horizontal and vertical projections of a line 5 ft. long whose inclination is  $27^\circ 13'$ .

3. What is the angle of elevation of the sun when a vertical pole 55.7 ft. tall casts a shadow 125 ft. long on the ground?

4. The angle between the horizontal arm of a crane and the cable is  $42^\circ 20'$ . What forces acting along the arm and cable would just balance a suspended load of 12,375 lb.?

5. Look up the sine and cosine of  $100^\circ 18'$ . Also find (to the nearest tenth of a minute) obtuse angles  $A$  and  $B$  for which  $\sin A = .28691$ ,  $\cos B = -.94837$ .

6. Find the distance  $AB$  across a pond if  $AC = 285$  ft.,  $BC = 319$  ft., and  $\angle ACB = 58^\circ 43'$ .

7. In a triangle  $ABC$ ,  $AB = 48$  in.,  $BC = 12$  in.,  $\angle C = 58^\circ$ . How large a force acting along  $AB$  would have a component of 10000 lb. along  $AC$ ?

### Chapter VI

1. Calculate to five significant figures:

$$(a) \sqrt{(76.47)^2 - (21.38)^2}, \quad (b) \left( \frac{\sqrt{32}}{6.5} + \sqrt[3]{.1} \right)^{\frac{3}{2}}, \quad (c) \sqrt[5]{\frac{-38.893\sqrt{.078}}{(-261.17)^2}}$$

2. If \$1 had been at 6% interest, compounded annually, from the beginning of the Christian era (say 1920 years), how large a gold ball

would be required to pay the amount due? Give the radius in miles. (1 cu. ft. of gold is worth \$362,620.)

3. If an investment *depreciates*, so as to lose in each year 5% of its value at the beginning of that year, in how many years will it have shrunk to one half the original value?

4. Ascending a hill by a straight path whose slope is .18, we see a tree straight ahead. Observed from two points  $A$  and  $B$  of the path 115.3 ft. apart, the tree top has elevation angles of  $15^\circ 10'$  and  $20^\circ 55'$  respectively. How far is the tree top from  $B$ ?

5. The sides of a triangle measure .312 mi., .423 mi., .342 mi. Find to five figures the length of the median upon the shortest side, using logarithmic methods.

6. (a)–(c) Solve by logarithmic methods the following problems on p. 187, (a) Ex. 21, (b) Ex. 22, (c) Ex. 26.

7. (a)–(c) The same as Ex. 6 for p. 183, Ex. 5, 6, 7.

## MISCELLANEOUS AND COMBINATION PROBLEMS

### Chapters I–VI

1. To determine the height of a flag-pole standing at  $A$ , the angle of elevation of its top viewed from a point  $B$  on the ground is measured ( $=9^\circ 4'.7$ ), also a line  $BC$  on the ground ( $=1158.7$  ft.) and angles  $ABC$  ( $=19^\circ 12'$ ) and  $ACB$  ( $=41^\circ 45'$ ) are measured. Find the height, accurate to five figures.

2. Sand, falling at the rate of 2 cu. ft. per min., forms a conical pile whose vertex angle is constantly  $140^\circ$ . How fast is the base radius changing at the instant when the radius is 10 ft.?

3. The speed ( $v$  ft. per min.) of a moving object  $t$  min. after starting was  $v = 5t^3(12 - t)$ . Find the distance traveled in the first 10 min. Also find when the speed was increasing most rapidly, and the maximum speed attained.

4. Plot a graph showing how the speed  $v$  in question (3) varied from  $t = 0$  to  $t = 12$ ; and check your answers to (3).

5. A certain grade of oil exerts against the wall of its container a pressure of  $60x$  lb. per sq. ft., at a depth of  $x$  ft. below the surface. (A) Explain precisely what this statement means, in view of the fact that no square foot of wall could be at any one depth  $x$  ft. below the surface. (B) Express by an integral the total force exerted by the oil

against the circular wall of a cylindrical tank of radius 20 ft., down to any depth  $x$  ft.

6. An open reservoir has the shape of a hemisphere of radius 40 ft. How much water will it contain when the water is 30 ft. deep in the middle?

7. A bomb was thrown straight down with an initial speed of 30 ft. per sec. from a balloon 3500 ft. high at the instant when an auto running 120 ft. per sec. passed straight under it. Find the distance of the auto from the bomb 10 sec. later, and how fast that distance was then increasing.

8. In Ex. 7 when was the bomb nearest to the auto?

9. Find the least possible weight for a cylindrical boiler which is to contain 1375 cu. ft., figuring 11.2 lb. to each sq. ft. of surface.

10. Starting with an initial velocity of 100 ft. per sec., a point moves along a straight line; its acceleration after  $t$  sec. varying as in Table I. Discover the formula for the acceleration. Then find the distance traveled at any time.

TABLE I

$t$	0.	1.2	2.7	4.5	6.
Acc.	2.5	3.3	4.3	5.5	6.5

11. The electromotive force ( $E$  volts) in a thermo-electric circuit increases with the temperature ( $T^\circ$ ) of the hot junction at the rate  $R = .9 + .013 T$ . If  $E = 1200$  when  $T = 400$ , what should it be when  $T = 500$ ?

12. If  $y = x^{101}$ , find the numerical value of  $dy/dx$  when  $x = .9875$ .

13. As a column of air ( $x$  in. long) was compressed in a cylinder, the force  $F$  lb. varied as in Table II. Find graphically the *rate* at which  $F$  was changing when  $x = 20$ ; and the work done while  $x$  changed from 20 to 12.

TABLE II

$x$	24	20	16	12	8
$F$	90.6	117.1	160.4	240.7	426.3

14. The formula for Table II is  $F = 8000/x^{1.41}$ . Calculate to five figures the rate and work in Ex. 13. (*N.B.* Here  $x$  decreases as  $W$  grows, making  $dW/dx$  negative. Change the sign in (13), p. 138.)

15. In Ex. 28, p. 188, change the 47 to 32, and solve.

16. A man bought a piece of property for \$1000, and another piece twenty years later for \$2000. He used the annual income to pay taxes and make improvements; and ten years after the second purchase sold both pieces for \$17,000. To what rate of interest, compounded annually, was this investment equivalent?

17. In how many years would \$1000 with 12% interest, compounded quarterly, amount to the same as \$2000 with 6% interest, compounded semi-annually, plus \$3000 with 3% compounded annually, during the same length of time?

18. Find the inclination of the curve  $y = 2x^3 - x^4$  at the point where the slope is increasing most rapidly. Also state just what steps would be needed in finding where the slope of this curve equals  $-30$ .

19. Integrate: (a)  $(2 - x^3)^2 dx$ ; (b)  $(2 - x^2)^{\frac{3}{2}} 15 x dx$ .

20. Water is poured from a cylindrical cup 4 in. in diameter until the surface of the liquid bisects the bottom of the cup, the bottom being then inclined  $38^\circ$ . Find the volume of water remaining and the area of the surface of water exposed to the air.

21. An airplane leaves the ground with an initial speed of 80 ft./sec., rising at a constant angle of  $5^\circ$ . If its acceleration after  $t$  sec. is  $12 - .6t$ , how far will it be after 10 sec. from a point on the ground 800 ft. straight behind the starting point?

22. Two forces,  $F$  lb. and 125 lb., include an angle of  $72^\circ 15'$  between their directions. If their resultant makes an angle of  $31^\circ 8'.6$  with the 125 lb. force, find  $F$ . Solve by measurement and by trigonometry.

23. A beam 40 ft. long and weighing 20 lb./ft. rests on piers at its ends  $A$  and  $B$ . A weight  $W = 6000$  lb. moves from  $A$  to  $B$  at the rate of 2 ft./sec. Find the supporting force  $F$  at  $B$  when  $W$  has gone  $x$  ft. How fast is  $F$  increasing when  $x = 30$ ?

24. A cylindrical tank is to contain 3000 cu. ft. The bottom including foundations will cost \$4 per sq. ft., the sides \$2 per sq. ft., and the top (in the form of a hemispherical dome) \$1 per sq. ft. Find to the nearest dime the least possible cost.

25. The force ( $F$  lb.) required to stretch a certain wire  $x$  inches varied as in Table III below. Find graphically the total work done in

stretching the wire 1 inch. Also obtain a formula for  $F$  in terms of  $x$ , and from this calculate the same work exactly.

TABLE III

$x$	.2	.3	.5	.7	.8	1.0
$F$	34	51	85	119	136	170

**26.** Find the pressure of water against a vertical dam, trapezoidal in shape, which is 50 ft. wide at the bottom (10 ft. below the surface) and whose sides are inclined  $32^\circ$ . Also state clearly *how* you could proceed to find the depth below which half of all this pressure is sustained.

**27.** The horse-power transmitted by a certain machine belt varies thus with the speed:  $H = .48 V - .000026 V^3$ . Find the best speed.

**28.** The base of a solid is a circle of radius 25 in., and every vertical section perpendicular to one diameter is an isosceles triangle whose base angles are  $80^\circ$ . Find the volume.

**29.** A block of ice is drawn up an incline whose grade is  $44\%$  by means of a rope passed over a pulley 10 ft. directly above the top of the incline. If the block is to move at the rate of 2 ft./sec., how fast must the rope be drawn in when the block is 20 ft. down the incline?

**30.** A safety-valve stopper is held down by a level rod  $x$  in. long, weighing .1362 lb. per in., and pivoted at one end 4 in. from the valve. What force  $F$  lb. would blow the stopper out, for any  $x$ ? About how much larger is  $F$  if  $x = 20.015$  than if  $x = 19.996$ ?

## CHAPTER VII

### LOGARITHMIC AND EXPONENTIAL FUNCTIONS

#### CONSTANT PERCENTAGE RATES OF GROWTH

§ 159. **Our Aim.** The only functions thus far differentiated or integrated have been *Power Functions*, such as  $y = x^n$  or  $y = u^n$ . The great practical importance of these lies in the fact that it is very common in nature for one quantity to vary as a power of another.

We now proceed to study an entirely different mode of variation, which also is very common. A new type of formula will be required to represent the varying quantities studied. We shall see how to differentiate and integrate the new functions, and shall solve further varieties of problems on rates, maxima, etc.

§ 160. **Growing Like Compound Interest.** Many quantities in nature grow in the same way as a sum of money at compound interest, — or rather, as such a sum would grow, if the interest were compounded *exceedingly often* or *continuously*.

That is to say : Money at interest grows faster and faster. The *percentage rate* remains constant, as 6%, or  $3\frac{1}{2}\%$ , etc., but the *total rate* of growth (or number of dollars per year) increases, — being proportional to the amount accumulated at the beginning of the interest-period in question.

Thus, if we compound annually at 40%, the rate of growth at any instant (as at  $P$  in Fig. 78) will be 40% of the value at the beginning



of the year. If we compound semi-annually, the rate will be 40% of the value at the beginning of the half-year in which  $P$  lies. And so on.

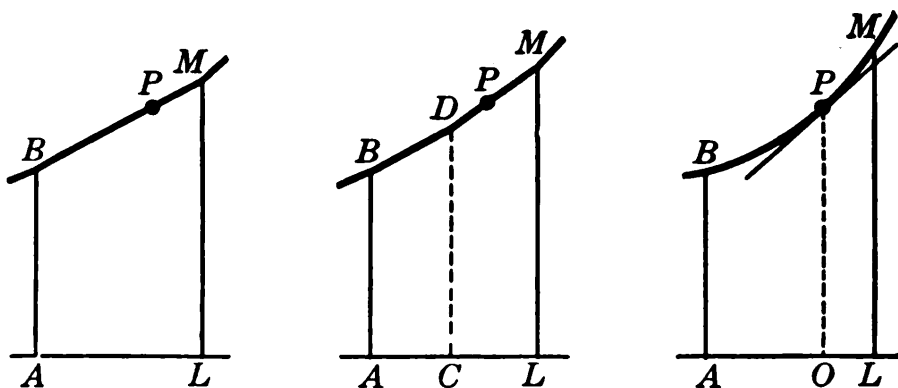

FIG. 78.

In each case  $AL$  represents 1 yr.

If the interest were compounded exceedingly often, say a trillion or more times a year, the periods would be so short that the rate at any instant would be practically *proportional to the amount at that same instant*. Just so for many quantities in nature: the larger they become, the faster they increase, — *proportionately*, — until stopped by modified physical conditions.

Many other quantities *decrease* in a similar way, — like an investment depreciating at a constant percentage rate, figured almost continuously.

**§ 161. Effect of Compounding Continuously.** To arrive at a formula for quantities of the kind just mentioned, let us see how the value of an investment will be affected if the interest is compounded exceedingly often.

Compounding  $k$  times a year, the amount is (by § 145):

$$A = P \left( 1 + \frac{r}{k} \right)^{kn}. \tag{1}$$

How will this be affected if  $k$  is indefinitely increased?

Consider first a special case: The amount on \$1 after 1 year with interest at 100%. Then  $P = 1$ ,  $n = 1$ ,  $r = 1$ , and

$$A = (1 + 1/k)^k. \tag{2}$$

Taking successively  $k=1$ ,  $k=10$ ,  $k=100$ , etc., we find the values of  $A$  shown in the following table. (Eight-place logarithms are needed to get the last two values accurately.)

Notice that, although we are increasing  $k$  faster and faster,  $A$  is increasing less and less rapidly, apparently *approaching some limiting value* near 2.718. In higher analysis this is definitely proved.

$k$	$A$	$k$	$A$
1	2	1000	2.717
10	2.594	10,000	2.718
100	2.704		

*Remark.* This limiting value of  $A$  is called the result of compounding *continuously*. The original dollar gains about \$1.718 during the year, or 171.8%. Hence compounding continuously at 100% is about equivalent to compounding annually at 171.8%.

§ 162. **The Number  $e$ .** The limit approached by the quantity  $(1+1/k)^k$  in (2) above, as  $k$  increases indefinitely (written  $k \rightarrow \infty$ ), is denoted by  $e$ :

$$e = \lim_{k \rightarrow \infty} \left(1 + \frac{1}{k}\right)^k. \quad (3)$$

This number is very important in what follows. Approximately:

$$e = 2.7183, \quad \log e = .43429.$$

*Remark.* \$1 with 100% interest, compounded continuously for one year, will amount to precisely  $e$  dollars.

§ 163. **General Formula.** Now consider the effect of compounding interest continuously for any number of years at any rate.

Returning to the standard formula

$$A = P \left(1 + \frac{r}{k}\right)^{kn}, \quad (4)$$

we are to let  $k \rightarrow \infty$  without giving special values to  $P$ ,  $r$ , and  $n$ . The problem is, however, reducible to the special case above by denoting  $r/k$  by  $1/z$ . For then  $k = zr$ , and

$$A = P\left(1 + \frac{1}{z}\right)^{zn} = P\left[\left(1 + \frac{1}{z}\right)^z\right]^n \quad (5)$$

Now, as  $k$  increases without limit, so must  $z$ . Hence the bracketed quantity in (5) varies in the same way as the  $k$ -quantity in (3), approaching  $e$ . Thus the limiting value of  $A$  in (5) is

$$A = Pe^{rn}. \quad (6)$$

This is the amount of any principal  $P$  after  $n$  years with interest *compounded continuously* at any annual rate  $r$ .\*

Similarly, if a physical quantity  $Q$  grows at a constant percentage rate  $r$  (per year, hour, or other unit of time), its value after  $t$  units must be

$$Q = Pe^{rt}. \quad (7)$$

**Ex. I.** The number of bacteria in a culture increased at a rate (per hr.) which was always 6% of the number then present. If the original number was 1000, how many were there after  $t$  hr.?

By (7), 
$$N = 1000 e^{.06t}.$$

The value of  $N$  at any time is easily calculated by logarithms, since  $\log N = \log 1000 + .06 t \log e$ , and  $\log e = .43429$ .

**Ex. II.** What rate of interest, compounded annually, will yield the same amount as 6% interest compounded continuously?

$$\begin{aligned} P(1+r)^n &= Pe^{.06n} \\ \therefore 1+r &= e^{.06} \end{aligned}$$

By logarithms this gives  $1+r = 1.0618$ ; whence  $r = 6.18\%$ .

*Remark.* Similarly in Ex. I, the number of bacteria is multiplied by  $e^{.06}$  or 1.0618, in each hour. Thus the gain is 6.18% of the number at the beginning of the hour, though the rate of gain is but 6% of the growing number at any instant.

\* Since formula (4) is strictly correct at the ends of all interest periods, (6) is correct at all times, and not merely for integral values of  $n$ .

Thus  $r$  in (7) is the *instantaneous* percentage rate, not the average percentage rate during a whole unit. Similarly  $r$  in (6) is the *nominal* rate used in compounding continuously, and not the effective rate actually realized.

**164. Depreciation.** For negative values of  $r$ , formula (4) above represents a depreciating investment. When  $r$  is negative, so is  $z$  in (5). But by Ex. 14, p. 241, the quantity  $(1 + 1/z)^k$  still approaches  $e$  if  $k \rightarrow \infty$ .

Hence formula (6) gives the value of an investment which depreciates at the nominal percentage rate  $r$ , *figured continuously*. If the rate is 8%, merely put  $r = -.08$ , getting  $A = Pe^{-.08n}$ .

The corresponding formula (7) evidently holds for any physical quantity  $Q$  which decreases in an analogous manner.

#### EXERCISES

1. Find the amount of \$1500 after  $t$  years with interest at 5%, compounded continuously. How much after ten years?

2. At what rate, compounding annually, would the final amount be the same as in Ex. 1?

3. In Ex. 1, when would the amount be \$5000?

4. An investment depreciated at a constant percentage rate of 6%, starting from an original value of \$75,000. What was its value after  $t$  years? After 10 yr.?

5. In Ex. 4, what percentage was actually lost per year? *Total*

6. In 1870 the population of a certain city (Portland, Ore.) was 8300, and this grew until 1910 almost like an investment with interest at 8%, compounded continuously.

(a) Write a formula for the population at any time ( $t$  years after 1870), on this basis.

(b) Compare the population in 1900 and in 1910 (90,500 and 207,200) with the values given by your formula. [If the formula had remained valid, what would the 1920 population have been?]

7. The number of bacteria in a culture increased at a rate (per hour) always equal to 30% of the number. Find how many there were at any time from an original 100. How many after 5 hours?

8. In Ex. 7, when had the original number doubled? *at*

9. Radium decomposes at a rate (per century) which at every instant equals 3.8% of the quantity  $Q$  remaining. How much will be left after 1000 years from a present quantity of 100 mg.?

10. The speed ( $V$ ) of a rotating wheel after the power was cut off decreased at a rate (per sec.) which at every instant was 25% of  $V$  itself. If  $V$  was originally 1000, what was its value after 10 sec.? When was the speed reduced to one tenth its original value?

11. The speed ( $V$ ) of a chemical reaction increases with the temperature ( $T$ ) at a rate constantly equal to 7% of  $V$ . If  $V=30$  when  $T=0$ , write a formula for  $V$  at any temperature. Find  $T$  for which  $V=60$ .

12. If the population of a state increases by 4% each year and is now 2,000,000, write a formula for the population  $t$  years hence. To what rate, figured continuously, would this be equivalent?

13. Calculate the value of the quantity  $(1+1/k)^k$  for  $k=1, 10, 100, 1000, 10000$ , — using 7 or 8 place tables if accessible.

14. The same as Ex. 13, for negative values of  $k$ .

§ 165. **Equivalent Forms.** Any such quantity as  $Q = Pe^{.02t}$  can be expressed also as a power of 10. For  $e = 10^{.43429}$  (§ 162);

$$\therefore Q = Pe^{.02t} = P(10^{.43429})^{.02t} = P 10^{.0086858t}.$$

That is, the forms  $e^{.02t}$  and  $10^{.0086858t}$  are equivalent. But the 2% rate which is clearly exhibited in the  $e$  form is entirely hidden in the 10 form. Thus the  $e$  form is the more natural.

§ 166. **Natural Logarithms.** Common logarithms are based upon the fact that every number is some power of 10. (§ 130.) But it is equally true that every number is some power of  $e$ . For instance

$$5 = e^{1.6094}.$$

We call this exponent 1.6094 the logarithm of 5 “to the base  $e$ .”

Logarithms to the base  $e$ , being exponents, follow the same four rules of combination as logarithms to the base 10. (§ 139.) Thus, the logarithm of a product equals the sum of the logarithms of the factors; etc.

The base  $e$  is naturally suited to calculations concerning the continuous compounding of interest.

*E.g.*, in calculating  $q$  from  $q = 30 e^{.02t}$  we should have, for any base:

$$\log q = \log 30 + .02 t \log e.$$

If the base is 10,  $\log e = .43429$ ; but if the base is  $e$ ,  $\log e = 1$  simply.

Similarly to find  $t$  if  $q$  were given, the base  $e$  would be the simpler.

The chief reason for introducing the base  $e$ , and regarding it as the "natural base," will, however, appear later.

**§ 167. Use of Table.** In the appendix (p. 502) there is a table of natural or "Napierian" logarithms, referred to the base  $e$  or 2.71828 ... . A few lines are reproduced here.

$N$	0	1	2	3	4	5	6	7	8	9
5.0	1.6 094	114	134	154	174	194	214	233	253	273
5.1	292	312	332	351	371	390	409	429	448	467
—	—	—	—	—	—	—	—	—	—	—
10.0	2.3 026	036	046	056	066	076	086	096	106	115

This means, for example:

$$\begin{aligned} \log 5.14 &= 1.6371; & \therefore 5.14 &= e^{1.6371}. \\ \log 10 &= 2.3026; & \therefore 10 &= e^{2.3026}. \end{aligned}$$

To find the logarithm of a number which lies beyond the limits of the table, we use the idea of Scientific Notation.

For instance,  $514 = 5.14 \times 10^2$ .

Hence, to get  $\log 514$ , we would look up  $\log 5.14$  and add twice  $\log 10$ :

$$\log 514 = 1.6371 + 4.6052 = 6.2423.$$

We do this, in fact, with the base 10; but then twice  $\log 10$  is simply 2.

Conversely, if given  $\log N = 6.2423$ , we would subtract  $\log 10$  twice, or  $2 \log 10$ , getting down to 1.6371. Then  $N$  must be the number which corresponds to 1.6371, multiplied by  $10^2$ :

$$N = 5.14 \times 10^2 = 514.$$

*Remark.* In solving an equation like  $749 = 135 e^{-0.06t}$  for  $t$ , it would simplify matters to divide through by 100, and have only the small numbers 7.49 and 1.35 to deal with.

## EXERCISES

1. Express as powers of 10:  $e^{-0.02t}$ ,  $e^{-0.04t}$ ,  $e^{12t}$ ,  $e^{-40t}$ .

2. Look up the natural logarithms of:

4.85, 92.6, 913, 278000, .0681, .00092.

Check each roughly by inspection, thinking of  $e$  as nearly 3.

3. The same as Ex. 2, interpolating for each given fourth figure:

6.283, 17.44, 60920, .005287.

4. Look up the numbers (to 3 figures) whose natural logarithms are:

2.0462, 5.3083, 9.3679, 9.2163 - 10, 6.9088 - 10.

5. The same as Ex. 4, interpolating to get a fourth figure, for

0.4682, 4.6928, 8.4179 - 10, 4.1263 - 10, 7.9182 - 10.

6. Calculate the following, using natural logarithms:

(a)  $A = 75 e^{-3.4826}$ , (b)  $y = 1500 e^{1.6295}$ , (c)  $Q = .45 e^{2.6578}$ .

7. Solve for the unknown  $n$  or  $r$ , after making any possible preliminary simplifications:

(a)  $985 = 159 e^{20r}$ , (b)  $.0485 = .075 e^{-.04n}$ .

(Hint: Both sides of any such equation may be multiplied or divided by 10, 100, etc., without affecting the exponent.)

8. Express as powers of  $e$ :  $2^x$ ,  $(1.06)^{4n}$ ,  $3^{1t}$ ,  $10^{-.3x}$ .

9. By means of common logarithms calculate for yourself the natural logarithm of 5, and compare with the table. [See §§ 154, 166.]

**§ 168. Compound Interest Law.** If any quantity  $y$  varies with another,  $x$ , in such a way that its *rate* of increase or decrease is constantly *proportional to its value*, it is strictly analogous to an investment whose interest or depreciation is figured continuously at a fixed percentage rate. (Cf. § 160.)

Such quantities are said to vary "according to the *Compound Interest Law*" (abbreviated *C. I. L.*)\*

\* Also called the Law of Organic Growth, or the Snowball Law.

Clearly, any such quantity is given by the formula

$$y = Pe^{rx} \quad (8)$$

where  $P$  is the value of  $y$  at  $x = 0$ , and  $r$  is the fixed percentage rate.

*E.g.*, if  $y$  decreases at a rate always equal to 15 per cent of  $y$ , then  $r = -.15$ , and  $y = Pe^{-.15x}$ .

Conversely, any quantity given by a formula of type (8) must vary according to the *C. I. L.* For instance, if given

$$y = Pe^{.09x}$$

we would recognize this as the formula for a quantity which increases at a rate constantly equal to 9% of its value.

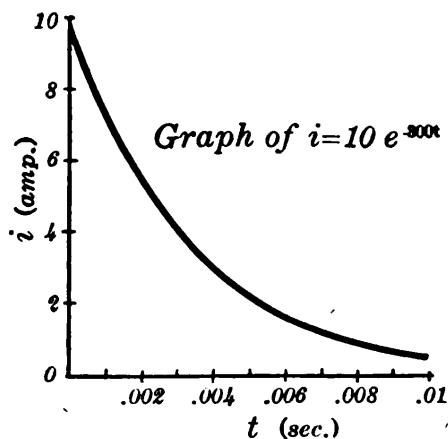

FIG. 79.

**Ex. I.** An electric current does not instantly vanish when the "EMF" is cut off; but it falls off rapidly, as in Fig. 79, decreasing at a constant percentage rate which is very great. If this rate is, say, 30000% per sec., then  $r = -300$ ; and if the original

intensity is 10 amperes, then, after  $t$  sec., it will be

$$i = 10 e^{-300t}.$$

**§ 169. Exponential Functions.** The functions  $2^x$  and  $x^2$  grow in very different ways. (See the table.) The value of  $2^x$  is quadrupled every time we increase  $x$  by 2; whereas  $x^2$  is quadrupled every time we double the value of  $x$ . In fact, these functions are of *entirely different kinds*. In one, we raise a fixed number to a higher and higher power; in the other, we raise a larger and larger number to a fixed power.

$x$	1	2	3	4	5	6
$2^x$	2	4	8	16	32	64
$x^2$	1	4	9	16	25	36



A variable raised to a fixed power is called a Power Function, as we have seen. (§ 55.) A constant raised to a variable power is called an *Exponential Function*. (The constant, however, is to be positive and not equal to 1.)

*E.g.*,  $2^x$ ,  $1.06^x$ ,  $10^{-3x}$ ,  $e^{-.08x}$ , and in general,  $b^{kx}$  are exponential functions.

Any quantity represented by an exponential function, or such a function times some constant, must vary according to the *C. I. L.*, — provided the exponent is of the first degree, as in the illustrations just given. For the constant base which is raised to the variable power is itself some power of  $e$ , and the given exponential function must therefore be reducible to a power of  $e$  in the type form (8), p. 244. An example will make this clear.

Ex. I. The speed  $v$  of a certain chemical reaction doubles with every  $10^\circ$  rise in the temperature. Obtain a formula for  $v$  at any temperature.

If  $v = P$  at  $T = 0$ , we have the following table.

$$\therefore v = P2^x = P2^{.1T}.$$

But by the table of natural logarithms:  $2 = e^{.6931}$ .

$$\therefore v = P(e^{.6931})^{.1T} = Pe^{.06931T}$$

which falls under (7) or (8) and is a case of the *C. I. L.*

$T$	$v$	$T$	$v$
0	$P$	30	$8P$
10	$2P$	—	—
20	$4P$	$10x$	$2^x P$

*Remark.* Any quantity which doubles, or gains a fixed percentage, at any regular intervals must increase according to the *C. I. L.*

It is therefore a characteristic feature of the Compound Interest Law, and of the corresponding formula  $y = Pe^{rt}$ , that *adding* a fixed amount to  $x$  will *multiply*  $y$  by a fixed amount.

§ 170. **Graphs.** Exponential functions are so important that we should be thoroughly familiar with their graphs. Consider the following standard forms.

$$\begin{array}{ll} \text{(I)} & y = e^x, \\ \text{(III)} & y = ae^{kx}, \end{array} \quad \begin{array}{ll} \text{(II)} & y = ae^x, \\ \text{(IV)} & y = ab^{kx}. \end{array}$$

By § 169 these all vary according to the *C. I. L.*, and their *rates* of increase are constantly proportional to their *values*.

The graph for (I) runs as in Fig. 80. The higher the curve, the faster it rises. Toward the left the curve approaches

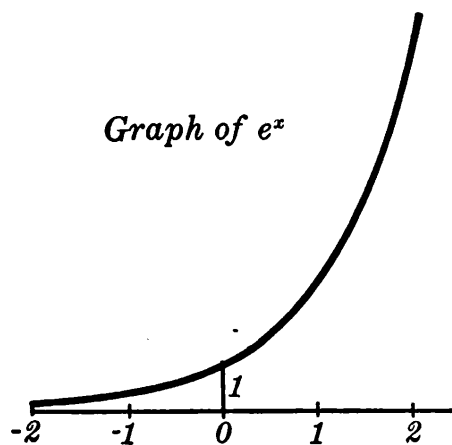

FIG. 80.

the base line indefinitely, never reaching it. (At  $x = -100$ ,  $y = e^{-100}$ . What does  $e^{-100}$  mean?)

The graph for (II) is the same, except that every ordinate is  $a$  times as great. With a change of scale, Fig. 80 would do, provided  $a$  were positive. (What if  $a$  were negative?)

In (III) the values of  $y$  at  $x = 1, 2, 3, \dots$ , are the same as those in (II) at  $x = k, 2k, 3k, \dots$ .

If  $k$  is positive the graph is the same as for (II), with a change in the horizontal scale. If  $k$  is negative, the graph is reversed as regards positive and negative values of  $x$ . It then falls toward the right, and is the typical “die-away curve.” (Cf. Fig. 79, p. 244.)

The form (IV) is reducible to one of the preceding forms, and thus has the same graph, to some scales.

The graph, however, is very different when the exponent involves anything beyond the first power of  $x$ . *E.g.*, the function  $y = e^{-x^2}$ , which is very important in statistical studies, varies very nearly as in Fig. 6, p. 5.

## EXERCISES

1. Plot the graph of  $y = e^x$ , taking  $x = 0, .5$ , etc., to  $x = 2.5$ . Over the same base line plot  $y = \log x$  from  $x = 1$  to 10. Is there any similarity between the two curves? For what reason?

2. Draw the graphs of the following functions roughly by inspection, merely showing the general shape and location:

$$(a) y = 20 e^{2x}, \quad (b) y = .055 e^{6x},$$

$$(c) y = 900 e^{-3x}, \quad (d) y = .4 e^{-.006x}.$$

3. The number of bacteria in a culture increased at a constant percentage rate of 40%, the unit of time being 1 hr. If  $N = 1000$  at  $t = 0$ , write a formula for  $N$  at any time. When was  $N = 6000$ ?

[4.] In Ex. 3 plot a graph showing how  $N$  increased, from  $t = 0$  to  $t = 5$ . Also plot another graph showing how  $\log N$  varied. Can you explain the peculiarity of the latter?

5. Write a formula for a quantity  $Q$  which equals 50 at  $t = 0$  and  
(a) increases at the constant percentage rate of 17%, 85%, 230%;  
(b) decreases at the constant percentage rate of 35%, 1.6%, 3000%.

6. Express as a power of  $e$ :  $y = P 3^{2x}$ . What percentage rate?

§ 171. **Semi-logarithmic Graphs.** In studying the variation of a given quantity  $y$ , it is sometimes desirable to plot a graph showing how the logarithm of  $y$  varies with the independent variable  $x$ . (Fig. 81.)

Such a "semi-logarithmic graph," as it is called, will always be a straight line when  $y$  varies according to the *C. I. L.*,

$$y = P e^{rx}. \quad (9)$$

For, taking logarithms to any base, we must have

$$\log y = \log P + rx \log e. \quad (10)$$

And as this equation is of the first degree in terms of  $\log y$  and  $x$ , the two quantities plotted, the graph must be straight. (Ex. 2, p. 44.)

*Conversely*, if that graph is straight,  $y$  must obey a *C. I. L.* (Why?)

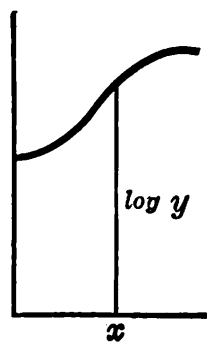

FIG. 81.

§ 172. **Use in Statistical Problems.** The characteristic feature of the *C. I. L.* is that  $y$  varies at a constant percentage rate. Hence we may say that whenever a quantity increases or decreases at a constant percentage rate, *its semi-logarithmic graph will be straight.* And conversely.

For this reason such graphs are much used by statisticians in studying the growth of populations, bank clearings, bonded

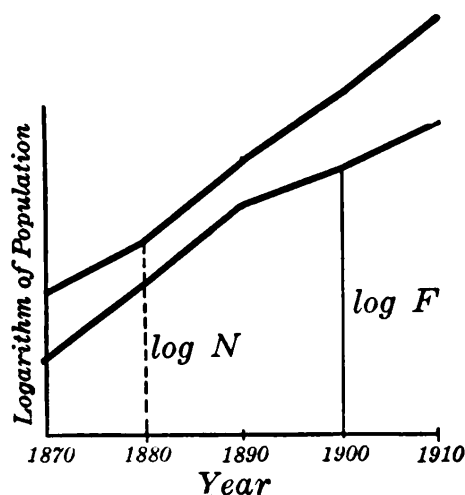

FIG. 82.

indebtedness, etc. If the semi-logarithmic graph of a population is straight, the population has increased at a constant percentage rate. If not, we can see at a glance where the largest percentage gains were made, by simply noting where the graph is steepest. By comparing such graphs for many different populations, — *e.g.*, for the native and foreign-born populations of Portland, Ore., in Fig. 82, —

we can see which made the largest percentage gain in any interval.

This same idea is used by large business houses in comparing the gains made by different departments of the business, or in comparing the growth of their business with the volume of postal receipts or other indications of general business conditions.

§ 173. **Semi-logarithmic Paper.** To make it easy to plot semi-logarithmic graphs, a specially ruled paper has been devised. Horizontally it has a uniform scale, to represent values of  $x$ ; vertically, a logarithmic scale (like a slide-rule), to represent values of  $\log y$ . (See Fig. 83.)

The number on the vertical scale at any point is a value of  $y$ , but the height of that point above the base line is  $\log y$ . Thus the distance up to the point marked "10" is  $\log 10$ , —

or 1 unit, using the base 10. The distance up to "100" is  $\log 100$ , or 2 units. And so on. To erect an ordinate equal to  $\log 20$ , we have merely to run it up to the cross-line marked "20," etc.

Hence if we plot a given table of values ( $x$  and  $y$ ), without looking up any logarithms, the paper will automatically plot  $\log y$  as a function of  $x$ , — *i.e.*, will plot the semi-logarithmic graph. Similarly, if given a formula, we have simply to calculate a table by substituting in the formula, and then plot.

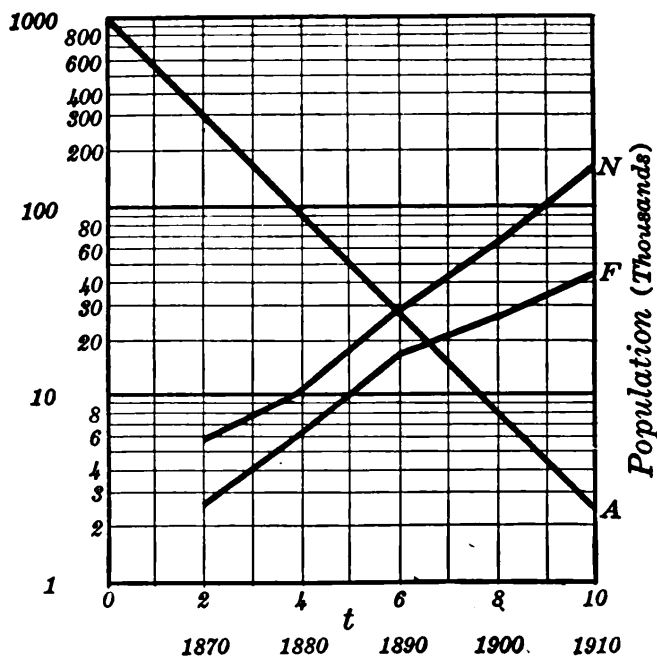

FIG. 83.

In case the formula is a *C. I. L.* two points will be enough, as the graph must be straight.

Ex. I. Plot the semi-logarithmic graph of  $y = 1000 e^{-.6t}$ .

When  $t=0$ ,  $y=1000$ . When  $t=10$ ,  $y=100 e^{-6} = 2.5$ , approx.

Plotting these two values of  $y$ , and joining by a straight line gives the required graph. (Fig. 83, A.) Observe that further values of  $y$  satisfying the given formula can now be read off directly. *E.g.*,  $y=91$  when  $t=4$ .

Ex. II. The native and foreign-born populations of Portland, Ore., have increased as shown in the table below. Plot the semi-logarithmic graphs.

Taking the numbers of the vertical scale as thousands rather than units, we get Fig. 83, *F*, *N*, — the same graphs as in Fig. 82, but obtained now without looking up logarithms.

These graphs do not give intermediate values correctly, unless the percentage rate of growth was constant during the interval considered.

YEAR	NATIVE	FOREIGN	YEAR	NATIVE	FOREIGN
1870	5700	2600	1900	64600	25900
1880	11300	6300	1910	163400	43800
1890	29100	17300			

## EXERCISES\*

1. Table 1 shows the approximate number of telephones in use in the United States at different times. Plot the ordinary and semi-logarithmic graphs. (Does the latter graph show any facts which the former does not?) How many telephones in 1902? In 1913?

TABLE 1

YEAR	No.	YEAR	No.
1895	280 000	1910	5 140 000
1900	630 000	1915	8 640 000
1905	2 030 000		

2. Table 2 shows (in millions) the assets of a certain life insurance company at various times, and also the amount of insurance in force. Plot the semi-logarithmic graphs on the same sheet. Any peculiar fluctuations?

TABLE 2

YEAR	A	INS.	YEAR	A	INS.
1867	3	37	1897	103	413
1877	18	64	1907	233	882
1887	29	148	1917	394	1604

\* The scales printed on the paper usually run from 1 to 10 and repeat. We re-label them to fit the problem. Thus the first "1" might be taken as 100, the next as 1000, etc., making the first "2" mean 200, etc. Evidently "200" should come just as far above "100" on the scale as "2" above "1." For  $\log 200 - \log 100 = \log (200/100) = \log 2$ .

Accurately ruled paper can be obtained from dealers in scientific supplies. But paper good enough for rough practice can be run off on a mimeograph.

3. Using the mortality table, p. 9, plot the semi-logarithmic graph of the number of survivors. Does the percentage rate of decrease become continually greater? (The absolute or total rate does not.)

4. The net profits of several firms in 1914 and 1916 are shown in Table 3. Show these on semi-logarithmic paper. In which case was the percentage increase greatest? Least?

TABLE 3

	1914	1916		1914	1916
A	1 450 000	10 992 000	C	5 590 000	43 594 000
B	350 000	5 983 000	D	36 000	5 090 000

5. Plot the semi-logarithmic graph of the formula  $y = 20 e^{-4x}$ .

6. The quantity of radium remaining after ( $t$ ) years from an original 1000 mg. is given approximately by the formula  $Q = 1000 e^{-.00038t}$ . Plot the semi-logarithmic graph, using  $t=0$  and  $t=5000$ . Read off intermediate values, and compare Table 3, p. 17.

7. Atmospheric pressure varies with the elevation according to the *C. I. L.* At  $h=0$ ,  $p=30$ , and at  $h=30,000$ ,  $p=9.5$ . Plot the semi-logarithmic graph and read off  $p$  when  $h=6000$  and  $12,000$ .

8. The population of a state increased in 10 years from 518,000 to 1,142,000. Assuming the percentage rate to have been constant, what was the population at the middle of the decade?

9. The population (in millions) of the United States has grown as in Table 4. Plot a semi-logarithmic graph. Note how long the percentage rate was practically constant.

[10.] In the formula  $y = .2 x^2$  plot a graph showing how  $\log y$  varies with  $\log x$ . Explain the peculiar result.

TABLE 4

YEAR	POP.	YEAR	POP.
1790	3.9	1860	31.4
1800	5.3	1870	38.6
1810	7.2	1880	50.2
1820	9.6	1890	62.9
1830	12.9	1900	76.0
1840	17.1	1910	92.0
1850	23.2	1920	105.7

**§ 174. Logarithmic Graphs.** In some statistical work where it is necessary to handle very large and very small values of  $y$  and  $x$ , it is customary to plot the logarithms of both variables, — *i.e.*, to plot a graph showing how  $\log y$  varies with  $\log x$ . This greatly tones down the contrasts. *E.g.*,  $\log 100000$  is only 5, and  $\log .001$  is  $-3$ .

Such “logarithmic graphs” are, however, mainly useful in scientific work in studying *Power Laws*:

$$y = kx^n. \quad (11)$$

For any such law, the logarithmic graph is straight. For

$$\log y = \log k + n \log x, \quad (12)$$

and this equation is of the first degree in terms of  $\log y$  and  $\log x$ , the two quantities plotted.

Conversely, whenever the logarithmic graph is straight,  $y$  must vary according to the *Power Law*. For by § 32 the relation between  $\log y$  and  $\log x$  must be linear, — say  $\log y = a \log x + b$ . And as this is of the form (12), equation (11) must hold, for some values of  $k$  and  $n$ .

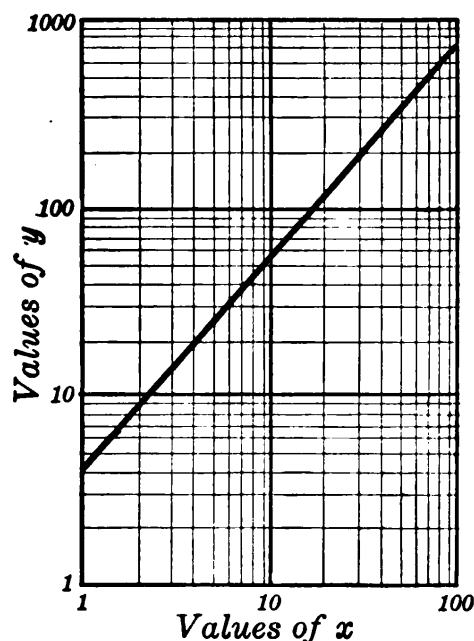

FIG. 84.

When  $x = 1$ ,  $y = 4$ . When  $x = 100$ ,  $y = 4(100)^{1.13} = 728$ , approx.

Plotting these values and drawing a straight line through the resulting points gives the required graph. (Fig. 84.)

Logarithmic graphs can be plotted without looking up any logarithms, by using a special “logarithmic paper.” This is ruled with logarithmic scales both horizontally and vertically. (Fig. 84.) A point for which  $x = 20$  and  $y = 8$  has its actual distances from the reference lines equal to  $\log 20$  and  $\log 8$ .

Ex. I. Plot the logarithmic graph of the Power Law,  $y = 4 x^{1.13}$ .



**§ 175. Discovering Scientific Laws.** As noted in § 32 many scientific laws are discovered experimentally. A table of values (of  $x$  and  $y$ , say) is obtained by observation; and various mathematical tests are then applied to ascertain what formula or formulas are satisfied by the tabulated values.

A simple test for the three most common types of law (§§ 32, 55, 168) can be made by plotting certain graphs:

- (I) *Ordinary graph straight: Linear Law,  $y = ax + b$ ,*
- (II) *Logarithmic graph straight: Power Law,  $y = kx^n$ ,*
- (III) *Semi-logarithmic graph straight: C. I. L.,  $y = Pe^{rx}$ .*

If none of these graphs is straight, the law is not one of these types. Tests for some other types will be discussed in §§ 323–324\*.

If the test shows a given table to satisfy one of these laws, the required constants ( $k, n$ ) or ( $P, r$ ), etc., can be found by merely substituting two pairs of values in the proper formula, and solving algebraically. (Cf. § 32.)

Ex. I. Discover the formula for the following table.

$x$	1	2	4	6	8	10
$y$	3.3	5.4	14.8	40.2	109.2	296.8

The semi-logarithmic graph turns out to be straight. Hence the required formula is a *C. I. L.*:

$$y = Pe^{rx}.$$

Substituting the first and last values of the table:

$$\begin{aligned} 3.3 &= Pe^r, \\ 296.8 &= Pe^{10r}. \end{aligned}$$

Taking logarithms:

$$\begin{aligned} \log 296.8 &= \log k + 10 r \log e, \\ \log 3.3 &= \log k + r \log e. \end{aligned} \tag{13}$$

\* In some cases it may be necessary to plot two semi-logarithmic graphs: one with  $y$  plotted vertically, and the other with  $x$ . We may not know in advance which to treat as the function varying according to the *C. I. L.*

Looking up the logarithms of 296.8 and 3.3 (either to the base  $e$ , with  $\log e = 1$ , or to the base 10, with  $\log e = .43429$ ), and subtracting, we find  $r = .5$ , approx. Substituting this in either equation of (13) gives  $k = 2$ . Hence the required formula is finally

$$y = 2 e^{.5x}.$$

*N.B.* When  $\log k$  happens to come out negative, we add 10–10. Thus  $\log k = -.175000$  would be the same as  $\log k = 8.25000 - 10$ , which could easily be looked up.

### EXERCISES

1. The attraction ( $f$  dynes) between two electric charges was found to vary with the distance ( $x$  cm.) apart as in Table 1 below. Find the formula and check.

2. Determine what kind of formula is satisfied by the values in each of the Tables 2 and 3.

3. A cold plate was taken into a warm tunnel. The difference between the temperatures of the air and the plate decreased as in Table 4 after  $t$  hours. Find the formula for  $D$  at any time.

4. Plot the logarithmic graphs of the following:

(a)  $y = 1/x$  from  $x = 1$  to  $x = 100$ . Read off the reciprocals of 4.52; 25; 69.8.

(b)  $y = \sqrt{x}$  from  $x = 1$  to  $x = 100$ . Read off the square roots of 6 and 50.

5. The rate of rotation of a wheel under water decreased as in Table 5 after the power was cut off. Find a formula for  $R$  at any time.

6. The speed of a certain chemical reaction doubles every time the temperature is raised  $10^\circ$  C. Calling the speed 1 at  $20^\circ$ , make a table of its values at several other temperatures and find a formula which will represent the Table.

TABLE 1		TABLE 2		TABLE 3		TABLE 4		TABLE 5	
$x$	$f$	$x$	$y$	$x$	$y$	$t$	$D$	$t$	$R$
.5	144.	1	5.	1	5	0	29.4	0	3000
1.0	36.	20	5.6	8	14	.5	22.1	10	1348
5.0	1.44	400	54.8	50	35	1.0	16.6	20	606
20.0	.09	700	331.4	200	71	1.5	12.5	30	273
		1000	2004.	450	106	2.0	9.4	40	122

7. The number of bacteria in a culture increased as in Table 1, p. 16. Discover the formula.

8. Discover the law satisfied by the following values of the pressure exerted by an expanding volume of steam :

$v$	8	10	20	30	40	50	60	70	80
$p$	125	92.8	36.8	21.5	14.6	10.9	8.5	6.9	5.8

9. The distances of the planets from the sun and their periods of revolution ( $T$  yr.) are given below. Discover the law. ("Kepler's Third Law.")

$D$	<i>Merc.</i> .387	<i>Venus</i> .723	<i>Earth</i> 1.00	<i>Mars</i> 1.52	<i>Jup.</i> 5.20	<i>Sat.</i> 9.54	<i>Ur.</i> 19.2	<i>Nep.</i> 30.1
$T$	.24	.615	1.00	1.88	11.9	29.5	84	165

§ 176. **Derivative of  $\log x$ .** In many problems it is necessary to know just how the logarithm of a number changes with the number, — in other words, how the function  $\log x$  varies with  $x$ .

To find a formula for the derivative or *rate* of increase at any instant we resort to the increment process. (§ 53.)

Let  $y = \log x$ , to any base.

Then  $y + \Delta y = \log (x + \Delta x)$ .

$$\therefore \frac{\Delta y}{\Delta x} = \frac{\log (x + \Delta x) - \log x}{\Delta x}. \quad (14)$$

The final step is to find the limit of this fraction as  $\Delta x \rightarrow 0$ . The numerator approaches  $\log x - \log x$ , or zero. Thus we have a quantity which is becoming very small, divided by another, also becoming very small. Without more information no one can tell what limit the fraction will approach.

But we can simplify the numerator. Subtracting one logarithm from another gives the logarithm of a fraction :

$$\therefore \frac{\Delta y}{\Delta x} = \frac{\log\left(\frac{x+\Delta x}{x}\right)}{\Delta x} = \frac{\log\left(1+\frac{\Delta x}{x}\right)}{\Delta x}. \quad (15)$$

To simplify this further make the substitution :

$$\frac{\Delta x}{x} = \frac{1}{z}, \quad \text{or} \quad \Delta x = \frac{x}{z}. \quad (16)$$

Then equation (14) becomes

$$\frac{\Delta y}{\Delta x} = \frac{\log\left(1+\frac{1}{z}\right)}{\frac{x}{z}} = \frac{z \log\left(1+\frac{1}{z}\right)}{x}.$$

But multiplying a logarithm by  $z$  gives the logarithm of the  $z$ th power.

$$\therefore \frac{\Delta y}{\Delta x} = \frac{\log\left(1+\frac{1}{z}\right)^z}{x}.$$

We can now see what happens as  $\Delta x \rightarrow 0$ . By (16),  $z$  must increase indefinitely. And by § 162, the quantity  $(1+1/z)^z$  approaches  $e$ , so that the limit approached by  $\Delta y/\Delta x$  is

$$\therefore \frac{dy}{dx} = \frac{\log e}{x}. \quad (17)$$

This is the derivative of  $y = \log x$ , no matter what base of logarithms is used.

If the base is  $e$ ,  $\log e = 1$  simply. Hence

$$\text{if } y = \log_e x, \quad \frac{dy}{dx} = \frac{1}{x}. \quad (18)$$

But if the base is 10,  $\log e = .43429$ , approx. (denoted by  $M$ ). Thus

$$\text{if } y = \log_{10} x, \quad \frac{dy}{dx} = \frac{M}{x}. \quad (19)$$

*Remarks.* (I) These formulas show that the rate at which a logarithm increases with the number is inversely proportional to the size of the number. Geometrically stated: The graph of  $\log_e x$  has a slope of 1 at  $x=1$ , a slope of  $\frac{1}{2}$  at  $x=2$ ,  $\frac{1}{3}$  at  $x=3$ , etc.

(II) Formulas (17)–(19) rest ultimately on the existence of the limit  $e$ , — proved in higher analysis, but assumed in this course. Compare (16) above with the substitution used in § 163.

(III) Observe that  $e$  is the *natural* base to use in problems requiring the differentiation of a logarithm, — because of the simplicity of formula (18) as compared with (19). In calculus, when no base is specified,  $e$  is always understood, not 10.

§ 177. **Log  $u$ .** To differentiate the logarithm of a *quantity*, say

$$y = \log u, \quad (20)$$

we use the same principle as in differentiating a power of a quantity,  $y = u^n$ . That is, we multiply  $dy/du$  by  $du/dx$ . (§ 76.) Here

$$\begin{aligned} \frac{dy}{du} &= \frac{1}{u} \\ \therefore \frac{dy}{dx} &= \frac{1}{u} \frac{du}{dx} \end{aligned} \quad (21)$$

Thus, *the derivative of the logarithm of any quantity equals one divided by that same quantity, times the derivative of that quantity.* (Memorize.)

Ex. I. 
$$y = \log (x^3 - 1).$$

$$\frac{dy}{dx} = \frac{1}{x^3 - 1} \cdot 3x^2.$$

*Remark.* It is instructive to compare this with a *power* case, say

$$\begin{aligned} y &= (x^3 - 1)^{100}, \\ \frac{dy}{dx} &= 100(x^3 - 1)^{99} \cdot 3x^2. \end{aligned}$$

Note the final factor  $3x^2$  in each case.

Ex. II. 
$$y = \log x^3.$$

$$\frac{dy}{dx} = \frac{1}{x^3} \cdot 3x^2 = \frac{3}{x}.$$

This result could have been foreseen,  $\log x^3$  being the same as  $3 \log x$ .

Ex. III. 
$$y = \log \sqrt{\frac{x^4 - 1}{x^4 + 1}}.$$

This can be simplified greatly *before differentiating*. By § 139, the logarithm of the radical equals one half the logarithm of the fraction. And the latter equals what?

$$\therefore y = \frac{1}{2} [\log (x^4 - 1) - \log (x^4 + 1)].$$

Each of these logarithms is easily differentiated.

$$\frac{dy}{dx} = \frac{1}{2} \left[ \frac{1}{x^4 - 1} \cdot 4x^3 - \frac{1}{x^4 + 1} \cdot 4x^3 \right] = \frac{4x^3}{(x^4 - 1)(x^4 + 1)}.$$

*N.B.* We cannot yet differentiate the fraction  $(x^4 - 1)/(x^4 + 1)$ , without resorting to the  $\Delta$  process. (§ 53.) But, curiously, we have just differentiated the logarithm of the square root of that fraction!

§ 178.  $\int \frac{1}{x} dx$ . In Chapter IV we could not find this integral, because there is no *power* of  $x$  whose derivative is  $1/x$ , or  $x^{-1}$ . But we now see that

$$\int \frac{1}{x} dx = \log_e x + C. \quad (22)$$

Hence we can now integrate *every* power of  $x$ :  $x^{-1}$  by (22) and any other power  $x^n$  by (8), § 92.

*Remark.* It is also true that

$$\int \frac{1}{x} dx = \frac{1}{M} \log_{10} x + C. \quad (23)$$

But this formula is not used if tables of natural logarithms are at hand.

Ex. I. The force ( $F$  lb.) driving a piston varied thus with the distance ( $x$  in.):  $F = 6000/x$ . Find the work done from  $x = 10$  to  $x = 20$ .

Always  $W = \int F dx$ . (§ 96.) In the present case,

$$W = \int \frac{6000}{x} dx = 6000 \int \frac{1}{x} dx.$$

$$\therefore W = 6000 \log x + C.$$

Now the work starts (*i.e.*,  $W = 0$ ) when  $x = 10$ .

$$\therefore C = -6000 \log 10,$$

and  $\therefore W = 6000 \log x - 6000 \log 10.$

This is the work done from  $x = 10$  to any other  $x$ . To  $x = 20$ :

$$W = 6000 (\log 20 - \log 10) = 6000 \log 2.$$

By the table of natural logarithms,  $W = 416$  (in.-lb.), approx.

### EXERCISES

1. Find the instantaneous rate of increase of  $y = \log_e x$  at  $x = 2, 4,$  and  $8$ . Check the last value by finding from the tables the average rate of increase in  $\log x$  from  $x = 7.99$  to  $8.01$ .

2. Approximately how much does  $\log_e x$  increase while  $x$  increases from  $2$  to  $2.0003$ ? If  $\log_e 2 = .69315$ , find  $\log 2.0003$ .  $\hat{?}$

3. Plot  $y = \log_e x$  from  $x = 1$  to  $x = 10$ , and check the results in Ex. 1.

4-6. Proceed as in Exs. 1, 2, 3, using the base  $10$ , and  $\log 2 = .30103$ .

7. Simplify and differentiate the following natural logarithms:

$$\begin{array}{llll} (a) y = \log x^{20}, & y = \log x^{7.5}, & y = \log x^{\frac{1}{2}}, & y = \log x^{-4}. \\ (b) y = \log 7x, & y = \log 1000x, & y = \log 5x^3, & y = \log .1x^{-\frac{1}{2}}. \\ (c) y = \log \sqrt{x}, & y = \log \sqrt[3]{x^5}, & y = \log (5/x^2), & y = \log (1/\sqrt[3]{x}). \\ (d) y = \log x^2 + 3 \log \sqrt{x} + 2 \log (1/x), & y = \log x^3 + 5 \log \sqrt[3]{x} + 7 \log (1/x^2). \end{array}$$

8. (a) Calculate the area under the curve  $y = 1/x$  from  $x = 1$  to  $x = 10$ .

(b) Check by plotting and measuring the area.

9. A rough table of logarithms could be constructed by measuring areas under the curve in Ex. 8. Explain briefly.

10. The force used in driving a piston varied thus:  $F = 1200/x$ . Find the work done from  $x = 20$  to  $x = 30$ .

11. Find the volume generated by revolving about the base line the area under the curve  $y = 1/\sqrt{x}$  from  $x = 2$  to  $x = 10$ .

12. The elevation ( $E$  ft.) above sea-level corresponding to any atmospheric pressure ( $p$  in.) is given by the formula:

$$E = 88630 - 60000 \log p. \quad (\text{Base } 10)$$

Approximately what change in elevation corresponds to a decrease of  $p$  from  $30$  to  $29.7$ ?

13. How fast is a balloon rising if the pressure recorded is decreasing at the rate of  $.5$  in./min. when  $p = 28$ ? (See Ex. 12.)

14. Find  $dy/dx$  for each of the following functions :

$$(a) \text{ Base } e : \quad y = \log(x^4 + 1), \quad y = \log(x^2 - 6x + 5);$$

$$(b) \text{ Base } 10 : \quad y = \log(x^2 - 25), \quad y = \log(1 - x^5).$$

*N.B.* In the following differentiations the base is  $e$ .

15. Differentiate in two ways and check :

$$y = \log x^{40}, \quad y = \log(500x), \quad y = \log(20x^4).$$

16. Simplify each of the following and then differentiate :

$$(a) y = \log \frac{x}{x^2 + 1}, \quad (b) y = \log \frac{x^2}{x^4 + 1},$$

$$(c) y = \log(x\sqrt{x^2 - 1}), \quad (d) y = \log \sqrt{\frac{x^2 - 1}{x^2 + 1}}.$$

17. Differentiate and simplify the results :

$$(a) y = x^2 - \log(x^2 + 1), \quad (b) y = \log(\log x).$$

18. What is the derivative *with respect to*  $x$  of :

$$y = \log u, \quad y = \log z, \quad q = \log r, \quad w = \log y.$$

**§ 179. Differentiating Logarithmically.** Many functions which we cannot yet differentiate directly are easily handled by introducing logarithms.

$$\text{Ex. I.} \quad y = \sqrt{\frac{x^4 - 1}{x^4 + 1}}.$$

Taking the logarithms of both sides, and simplifying as in § 177 :

$$\log y = \frac{1}{2} [\log(x^4 - 1) - \log(x^4 + 1)].$$

Differentiating each term *with respect to*  $x$  gives :

$$\frac{1}{y} \frac{dy}{dx} = \frac{1}{2} \left[ \frac{4x^3}{x^4 - 1} - \frac{4x^3}{x^4 + 1} \right] = \frac{4x^3}{(x^4 - 1)(x^4 + 1)}.$$

Now  $dy/dx$  is what we are after ; so we multiply through by  $y$ , and then substitute the value of  $y$  as originally given in terms of  $x$ .

$$\therefore \frac{dy}{dx} = \frac{4x^3}{(x^4 - 1)(x^4 + 1)} \cdot y = \frac{4x^3}{(x^4 - 1)(x^4 + 1)} \sqrt{\frac{x^4 - 1}{x^4 + 1}},$$

$$\text{or, simplified, } \frac{dy}{dx} = \frac{4x^3}{(x^4 - 1)^{\frac{1}{2}}(x^4 + 1)^{\frac{3}{2}}}.$$



*N.B.* It is desirable to simplify the logarithms as much as possible before differentiating, also to *combine the fractions* obtained in differentiating the right member, *before multiplying across by the given function*. Compare this example with Ex. III, § 177.

## EXERCISES

1. Differentiate logarithmically:

$$(a) y = \frac{x}{x^2 - 1},$$

$$(b) w = \sqrt{\frac{x-1}{x+1}},$$

$$(c) y = 7x^2(x^2 - 1)^4,$$

$$(d) q = 5x^3\sqrt{x^4 + 1}.$$

2. Plot  $y = 2^x$  and also  $y = x^2$ , from  $x = -3$  to  $x = 6$ , over the same base line. Observe how differently  $y$  varies in the two cases, even at the common points.

[3.] If  $y = 7e^{3x^2}$ , find  $dy/dx$  by introducing logarithms. Similarly prove that if  $y = e^u$ , then  $dy/dx = e^u du/dx$ .

§ 180. Derivative of  $e^u$ . Differentiating  $y = e^u$  logarithmically gives

$$\frac{dy}{dx} = e^u \frac{du}{dx}. \quad (24)$$

That is, *the derivative of any power of  $e$  is that very same power, times the derivative of the exponent.* (Memorize.)

Formula (24) bears no resemblance whatever to the formula  $d(u^n) = nu^{n-1}du$ . The reason is that an exponential function  $e^u$  varies in an entirely different way than a power function  $u^n$ . (§ 169.)

To differentiate an exponential function in any modified form, as  $a^x$ , first express it as a power of  $e$ .

$$\text{Ex. I.} \quad y = e^{-x^2}. \quad \text{Here } \frac{dy}{dx} = e^{-x^2}(-2x).$$

$$\text{Ex. II.} \quad y = 100e^{4t}. \quad \text{Here } \frac{dy}{dt} = 100e^{4t}(4).$$

This result is the same as 4  $y$ . Thus the rate is proportional to  $y$  itself. In fact the given formula is evidently a case of the *C. I. L.*

Ex. III.  $v = P \cdot 2^{.1T}$ .

This is an  $e$  form in disguise. In fact by Ex. I, § 169:

$$v = P \cdot e^{.06931T}.$$

$$\therefore \frac{dv}{dT} = P \cdot e^{.06931T} (.06931).$$

That is,  $dv/dT = .06931 v$ , which shows again that this  $v$  varies according to the *C. I. L.* Observe that the coefficient .06931 in the exponent ( $kT$ ) refers to the instantaneous rate of increase, rather than the average rate during an entire unit.

§ 181. *C. I. L.* by Integration. The general formula for the *C. I. L.*,

$$y = Pe^{rx}, \quad (25)$$

was obtained in § 168 by considering the analogy to an investment whose interest is compounded continuously. The formula can now be derived without any thought of that analogy. The method is precisely the same as in the following numerical illustration.

Ex. I. A quantity  $y$  increases with  $x$  at a rate constantly equal to  $.04 y$ . If  $y = 100$  at  $x = 0$ , find the formula.

*Solution.* We are given  $dy/dx = .04 y$ .

The problem, then, is simply to integrate this, and get  $y$  in terms of  $x$ .

There is one difficulty: as the equation stands, the derivative on the left side is taken with respect to  $x$ , whereas the right member is expressed in terms of  $y$ . But let us divide through by  $y$ :

$$\frac{1}{y} \frac{dy}{dx} = .04.$$

The left member is now the derivative of  $\log y$ , with respect to  $x$ . (§ 177.) Integrating with respect to  $x$  gives

$$\log y = .04 x + C.$$

But  $y = 100$  when  $x = 0$ , whence  $C = \log 100$ .

$$\log y = .04 x + \log 100.$$

Transposing  $\log 100$ , and remembering that the difference  $\log y - \log 100$  is the same as the logarithm of the fraction  $y/100$  (§ 139), we have

$$\log \frac{y}{100} = .04 x.$$

This means that  $.04 x$  is the *exponent* of the power to which the base  $e$  must be raised to equal the fraction  $y/100$ .

$$\therefore \frac{y}{100} = e^{.04x}, \quad \text{or } y = 100 e^{.04x}.$$

*Remarks.* (I) This formula is the same as would be obtained by thinking of the analogy to compound interest, the given quantity  $y$  growing at the rate of 4% compounded continuously.

(II) The formula can also be checked directly. Substituting  $x=0$  gives  $y=100$ ; and differentiating gives

$$\frac{dy}{dx} = 100 e^{.04x} (.04) = .04 y$$

as required.

### EXERCISES

1. Differentiate each of the following functions:

(a)  $y = 20 e^{.06x}$ ,

(b)  $i = 40 e^{-.30x}$ ,

(c)  $z = 10 e^{-x^2}$ ,

(d)  $y = (e^{2x} + e^{-2x}) + 5$ ,

(e)  $w = 7/e^{4x^3}$ ,

(f)  $y = (e^{3x} - e^{-3x})^2$ .

2. (a) Differentiate  $y = 3^{x^2}$  by expressing  $y$  as a power of  $e$ ; also by taking logarithms. (b) Likewise differentiate  $w = 10^{4x}$  in two ways.

[3.] By differentiating logarithmically prove that if  $y = uv$ , where  $u$  and  $v$  are functions of  $x$ , then  $dy/dx = u(dv/dx) + v(du/dx)$ .

[4.] As in Ex. 3 show that if  $y = u/v$ , then  $dy/dx = [v(du/dx) - u(dv/dx)] \div v^2$ .

5. To what interest problem is this equivalent: If  $y = 1000$  at  $t = 0$  and grows at rate always equal to  $.15 y$ , what will be the value of  $y$  at any time? Write the formula by inspection.

6. In Ex. 5 obtain the required formula also by integration.

7. The difference  $D$  between the temperature of a hot wire and that of the air decreased thus:  $dD/dt = -.6 D$ . To what sort of depreciation is this analogous? What formula if  $D = 100$  at  $t = 0$ ? Check.

8. In Ex. 7, derive the formula for  $D$  by integration.

*N.B. In Exs. 9-15, obtain each required formula by integration.*

9. An electrical current died out thus:  $di/dt = -60i$ . Derive the formula for  $i$  at any time if  $i = 30$  when  $t = 0$ .

10. In Ex. 9 plot a graph showing how  $i$  decreased, from  $t = 0$  to .1 at intervals of .02.

11. The number of bacteria in a culture increased thus:  $dN/dt = .3N$ . At the start,  $N = 20$ . Derive the formula.

12. In Ex. 11 draw by inspection a rough graph showing how  $N$  increased from  $t = 0$  to  $t = 9$ .

13. When an iron rod is heated its length increases thus:

$$dL/dT = .00001L.$$

Express  $L$  as a function of  $T$ , if  $L = 60$  (in.) when  $T = 0$ . At what temperature will  $L$  have increased by 1% of its original length?

14. Passing through dark glass the intensity of light varied with the distance ( $x$  in.) thus,  $di/dx = -.2i$ . If  $i$  was originally 60, derive a formula for  $i$  at any distance.

15. Atmospheric pressure varies thus with the height above sea-level:  $dp/dh = -.00004p$ . Find a formula for  $p$  at any height, knowing that  $p = 30$  when  $h = 0$ . Calculate  $p$  at  $h = 6000$ .

16. Each of the quantities mentioned below varies at a rate constantly proportional to the value of the quantity. In certain cases the constant of proportionality has the value shown. Express these facts in calculus notation, and write by inspection the result of each integration. Check each result by differentiating.

(a) Rotary speed, with the time elapsed since the power was cut off:  $k = -.02$ , and  $R = 100$  at  $t = 0$ .

(b) The length of a glass rod, with the temperature:  $k = .0000083$ ;  $L = 20$  when  $T = 0$ .

(c) Viscosity of olive oil, with temperature:  $k = -.023$  and  $V = 3.265$  when  $T = 0$ .

(d) An electric current, with time elapsed since the *E.M.F.* was cut off:  $k = -200$  and  $c = 10$  at  $t = 0$ .

(e) The quantity of sugar remaining  $t$  min. after being subjected to a certain acid:  $k = -.0014$  and  $Q = 300$  at  $t = 0$ .

(f) Tension in a pulley belt, with the distance along the pulley:  $k = .04$  and  $T = 30$  when  $D = 0$ .

17. The number of negative "ions" passing between two charged plates is given by the relation:  $dn = kn dx$ , where  $k$  is the gas constant, and  $x$  is the distance from the negative plate. Derive a formula for  $n$  at any  $x$ , if  $n = N$  at  $x = 0$ .

§ 182. **Derivative of a Product.** Any product can be differentiated logarithmically. But often it is more conveniently differentiated directly, by using the formula derived in Ex. 3, p. 263, viz. :

$$\frac{d}{dx}(uv) = u \frac{dv}{dx} + v \frac{du}{dx}. \quad (26)$$

That is, *the derivative of the product of two variables is equal to the first variable times the derivative of the second, plus the second variable times the derivative of the first.* (Memorize.)

Ex. I. Differentiate  $y = x^2 \log x$ .  
Here the first variable is  $x^2$  and the second is  $\log x$ .

$$\therefore \frac{dy}{dx} = x^2 \left( \frac{1}{x} \right) + \log x (2x);$$

$$\text{i.e.,} \quad \frac{dy}{dx} = x(1 + 2 \log x), \quad \text{simplified.}$$

§ 183. **A Typical Application.** Suppose that, under pressure, the height of a rectangular plate is decreasing at the rate of .05 in./min. and the base increasing .02 in./min. How fast is the area changing when  $h = 20$  and  $b = 15$ ?

$$\begin{aligned} A &= bh. \\ \therefore \frac{dA}{dt} &= b \frac{dh}{dt} + h \frac{db}{dt}. \end{aligned} \quad (27)$$

Substituting given values for  $b$ ,  $dh/dt$ , etc.,

$$\frac{dA}{dt} = 15(-.05) + 20(.02) = -.35.$$

The area is *decreasing* at the rate of .35 sq. in. per min.

§ 184. **Derivative of a Fraction.** Differentiating  $y = u/v$  logarithmically as in Ex. 4, p. 263, we find that

$$\frac{dy}{dx} = \frac{v \frac{du}{dx} - u \frac{dv}{dx}}{v^2}. \quad (28)$$

That is, *the derivative of a fraction equals the denominator times the derivative of the numerator, minus the numerator times the derivative of the denominator, all divided by the square of the denominator.* (Memorize.\*)

Ex. I. Find the maximum value of  $y = \frac{\log x}{x^4}$ .

By (28) 
$$\frac{dy}{dx} = \frac{x^4 \left(\frac{1}{x}\right) - \log x (4x^3)}{x^8};$$

i.e., 
$$\frac{dy}{dx} = \frac{1 - 4 \log x}{x^5}.$$

To find the maximum value of  $y$ , we set  $dy/dx = 0$ :

$$\frac{1 - 4 \log x}{x^5} = 0.$$

Multiplying through by  $x^5$  gives  $1 - 4 \log x = 0$ , or  $\log x = \frac{1}{4}$ .

Since the base is  $e$ , this means that

$$x = e^{\frac{1}{4}} = \sqrt[4]{e} = 1.284 \text{ approx.}$$

Substituting for  $x$  and  $\log x$  in the original equation:  $y = \frac{\frac{1}{4}}{e} = \frac{1}{4e}$ .

Test: At  $x=1$ ,  $dy/dx = +$ . At  $x=2$ ,  $dy/dx = -$ . Hence a maximum.

### EXERCISES

1. Differentiate and simplify the results:

- |   |  |
|---|--|
| (a) $y = (x^3 + 1)(x^2 - 4)$ ,                | (b) $y = (x^2 + 1)/(x^3 - 5)$ ,        |
| (c) $z = 2x^2 \log x - x^2$ ,                 | (d) $z = x^2 \cdot e^{4x}$ ,           |
| (e) $u = x \log x$ ,                          | (f) $u = x^2 \sqrt{25 - x^4}$ ,        |
| (g) $y = (\log x)/x^6$ ,                      | (h) $y = \frac{x^2}{x^4 - 1}$ ,        |
| (i) $w = \frac{e^x - e^{-x}}{e^x + e^{-x}}$ , | (j) $w = \frac{x}{\sqrt{x^2 + 400}}$ , |
| (k) $z = r\sqrt{100 + r^2}$ ,                 | (l) $s = t^3/(1 + t)^2$ .              |

2. Test for maxima and minima:

- |                          |                               |
|--------------------------|-------------------------------|
| (a) $y = (\log x)/x^3$ , | (b) $u = x^3 e^{-4x}$ ,       |
| (c) $y = x/(x^2 + 1)$ ,  | (d) $z = x\sqrt{100 - x^2}$ . |

\* A help in remembering the order in (28) is to observe that the formula begins and ends with  $v$ , the *denominator*. Notice also the negative sign between the terms, as against the positive sign in the product formula.

3. Differentiate  $y = (x^2 + 1)^2$  logarithmically and compare (22), p. 111. The same for  $y = u^n$ .

4. A rectangular metal block has a square base whose edge is increasing at the rate of .04 in./min. The height is increasing at the rate of .06 in./min. How fast is the volume changing when  $x=10$  and  $h=30$ ?

5. If the radius of a cylinder is increasing at the rate of .2 in./min. and the height is decreasing at the rate of .3 in./min., how fast is the volume changing when  $r=10$  and  $h=20$ ?

6. For a certain quantity of a gas  $PV=500 T$ . If  $P$  increases at the rate of .02 units per min., and  $V$  at the rate of .04 units per min., how fast will  $T$  increase when  $P=30$  and  $V=6000$ ?

7. In Ex. 6, if  $P$  increases at the rate of .05 per min. and  $T$  at the rate of .2 per min., how fast will  $V$  be changing when  $P=40$  and  $T=300$ ?

8. If one of two quantities is increasing at the rate of .02 per min. and the other decreasing at the rate of .04 per min., how fast is their product changing at the instant when the first equals 15 and the second equals 25?

9. How fast is the ratio of the first to the second changing in Ex. 8?

10. Approximately how much will the area of a rectangle change if the base and height increase slightly as in Fig. 85? Cf. § 182.

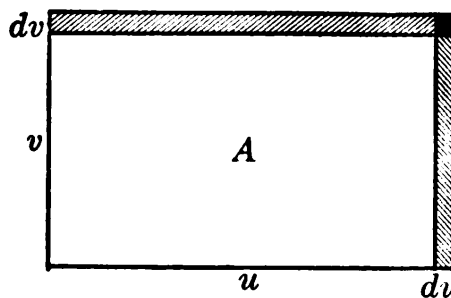

FIG. 85.

11. The speed of signals through an oceanic cable is proportional to the function  $S = (\log x)/x^2$ , where  $x$  is the ratio of the thickness of the covering to the radius of the core. Find the maximum value of  $S$ .

12. Find how high a wall-light  $L$  should be placed to secure the maximum illumination  $I$  of a level surface at  $S$  4 ft. from the wall, if  $I$  varies as the sine of  $\angle S$ , and inversely as the square of distance  $LS$ . [Show that the function to be tested is  $x/(16+x^2)^{\frac{3}{2}}$ .]

**§ 185. Summary of Chapter VII.** A quantity which varies according to the *C. I. L.* (§ 168) is strictly analogous to an investment whose interest is compounded continuously. Its value is expressible as an exponential function, — *i.e.*, as a varying power of  $e$  (§ 162) or of some other constant.

These formulas for the *C. I. L.* can be obtained either from this analogy or by integration.

Logarithms to the base  $e$  are the simplest and most natural in studying the *C. I. L.*, and also in differentiating and integrating.

The differentiation formulas for  $e^u$ ,  $uv$ ,  $u/v$ , and  $u^n$  have all been derived from the formula for  $\log u$ , which assumes the existence of the limiting value  $e$ . Thus all of our differentiation and integration formulas to date rest upon this assumption, — except that the formula for  $d(u^n)$  had already been derived independently in the case of an integral or fractional value of  $n$ . The  $(uv)$  and  $(u/v)$  formulas are also easily derived independently by the  $\Delta$  process.

The logarithmic method is the best for differentiating complicated products, roots, etc.

Logarithmic and semi-logarithmic plotting are useful in statistical work, and in discovering or studying Power Laws and Compound Interest Laws.

Many quantities which we have not yet studied vary in much the same way as some trigonometric function. To deal with these effectively we need some further graphical concepts, to the study of which we next turn.

### EXERCISES

1. What differentiation formulas have been covered so far in the course? Under which of these does each of the following forms come *primarily* :

$$y = \log(x^{10}), \quad y = (\log x)^{10}, \quad y = (\log x)/x, \quad y = e^{x^2}, \quad y = (e^x + 1)^{1/2}?$$

2. (a)–(e). Differentiate each of the functions in Ex. 1.

3. Differentiate each of the following functions :

$$(a) \quad y = (\log_{10} x)^3,$$

$$(b) \quad y = \log(x^2/\sqrt{x+1}),$$

$$(c) \quad y = (\log x)/x^5,$$

$$(d) \quad y = x/(\log x),$$

$$(e) \quad z = x^2\sqrt{x^4+1},$$

$$(f) \quad z = x^4e^{-10x},$$

$$(g) \quad w = \frac{t^2}{t^4-1},$$

$$(h) \quad w = \frac{e^t + e^{-t}}{e^t - e^{-t}},$$

$$(i) \quad y = x^2[(\log x)^2 - \log x + \frac{1}{2}],$$

$$(j) \quad y = e^{2x}(x^3 - \frac{1}{2}x^2 + \frac{3}{2}x - \frac{3}{4}).$$



4. Approximately how much should  $\log_e x$  increase while  $x$  runs from 1 to 1.000275? Hence  $\log 1.000275 = \dots$ ?

5. Find where the slope of the curve  $y = e^{-x^2}$  is a maximum or minimum.

6. For a certain gas, the pressure, volume, and temperature have this relation:  $pv = 50 T$ . If  $T$  increases  $.3^\circ/\text{min.}$  and  $p$  decreases  $.4$  units per min., how fast will  $V$  be changing when  $T = 320$  and  $p = 40$ ?

7. The speed of a point on a rotating wheel ( $v$  ft./sec.) varied thus:  $v = 400 e^{-2t}$ . Find a formula for the distance ( $x$  ft.) covered in any length of time.

8. A sum of money, drawing interest compounded continuously, doubles in 8 years. What is the nominal rate  $r$ ?

9. In how many years will any sum double, drawing 5% interest, compounded continuously?

10. The speed  $v$  of a certain chemical reaction increases thus with the temperature:  $dV/dT = .07 V$ . If  $V = 50$  when  $T = 0$ , write by inspection the formula for  $V$  at any temperature. Derive this also by integration. Find  $T$  when  $V = 500$ .

11. Draw by inspection a graph showing the general way in which  $v$  increased in Ex. 10, and showing plainly the values  $v = 50$ ,  $v = 500$ .

12. If a weight is to be suspended by a vertical rod, and the stress on every horizontal section of the rod is to be the same, the sectional area ( $A$  sq. in.) should vary thus with the elevation ( $x$  in.) above the bottom:  $dA/dx = kA$ . If  $A = 20$  when  $x = 0$ , find the formula for  $A$ . If  $k = .00002$ , will the change in  $A$  from  $x = 0$  to  $x = 150$  be appreciable?

13. The annual expenditure of the United States government (in millions) has increased as in Table I. Plot together the semi-logarithmic graphs of this and of the population for the same period. [See Table 4, p. 251.]

(I)

Yr.	1840	1850	1860	1870	1880	1890	1900	1910
Ex.	24	41	63	294	265	298	488	660

In which decade was the percentage rate of growth greatest for each? Smallest? Which rate was the larger in the decade 1900 to 1910?

14. In a recent year there were in the United States 320 personal incomes above \$500,000; 230 above \$1,000,000; and similarly for other incomes, shown in Table II. Plot the ordinary and also the logarithmic graph.

(II)

Income	3 000	5 000	10 000	25 000	50 000	100 000	200 000
Number	330 000	200 000	85 000	27 000	10 500	3 600	1 300

15. In Ex. 14 show that the tabulated values satisfy roughly the power law:  $N = 7\,300\,000\,000/I^{\frac{5}{4}}$ .

16. In an experiment with light passed through a pinhole the intensity was found to vary as in Table III with the distance ( $x$  in.) from the hole. Find the formula for  $I$ .

(III)

$x$	2	5	10	30	50
$I$	150	24	6	.67	.24

(IV)

$D$	0	1	5	10	15
$I$	100	81.9	36.8	13.5	5.0

17. The intensity of light passing through a solution of copper chloride varied with the depth ( $D$  cm.) as in Table IV. Find the law.

18. A wound treated by Dr. Carrel's method\* decreased in size ( $S$  cm.), after  $t$  days, as in Table V. Show that this follows roughly a  $C. I. L.$

(V)

$t$	0	2	4	5	7	10	12
$S$	6.2	4.7	3.5	3.0	2.2	1.3	1.0

19. Discover the formula for Table 8, p. 29. Also find by calculus the work asked for in Ex. 10, p. 29.

20. The following table shows the reading of a vacuum gauge  $t$  hours after the pump broke down. (One value is grossly incorrect.) Discover the law. Also correct the error in the table.

$t$	0	1	2	3	4	5
$R$	29.2	15.6	9.4	4.48	2.4	1.28

\* Cf. Ex. 6, p. 18.

## CHAPTER VIII

### RECTANGULAR COÖRDINATES

§ 186. **Locating Points.** A simple way to describe the location of a point  $P$  is to tell its distances  $x$  and  $y$  from two mutually perpendicular lines,  $XX'$  and  $YY'$ . (Fig. 86.)

To show on which side of each reference line or axis the point  $P$  lies, we use a  $+$  or  $-$  sign, calling  $x$  negative for points to the left of  $YY'$ , and  $y$  negative for points below  $XX'$ . Thus for the point  $A$ ,  $x = -6$ ,  $y = 4$ ; for  $B$ ,  $x = -8$ ,  $y = -3$ ; and for  $C$ ,  $x = 4$ ,  $y = -6$ .

The  $x$  and  $y$  of a point are called its *coördinates*:  $x$  the *abscissa* and  $y$  the *ordinate*.  $O$  is called the *origin*.

To designate a point we simply write its coördinates within parentheses,  $x$  first. Thus  $(-6, 4)$  denotes the point at which  $x = -6$  and  $y = 4$ .

The idea of coördinates is used in daily life. *E.g.*, we direct a man to some point in the city or country by telling him that it is, say, five blocks east and two blocks north; or three miles west and four miles south.

Coördinates afford the basis for the mapping of points, for the scientific study of motion, and also, as we shall presently see, for a very systematic and powerful method of studying geometry.

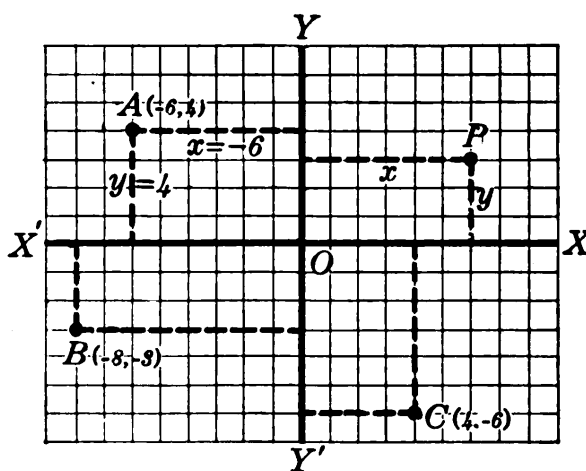

FIG. 86.

## (A) THE STUDY OF MOTION

§ 187. **Path of a Moving Point.** The motion of a point in any plane is conveniently studied *by means of its varying coördinates*  $(x, y)$ , referred to axes in the plane. If we have a table giving the values of  $x$  and  $y$  at various instants, we can map each successive position and draw the approximate path.

Still better, if we have a pair of equations giving the values of  $x$  and  $y$  *at any time*, we can calculate as many positions as we please, and study the motion in detail. Such "equations of motion" are used in studying the motions of projectiles, airplanes, parts of machines, points on the vibrating strings of musical instruments, etc.

Ex. I. The position of a projectile  $t$  sec. after firing was

$$x = 1000 t, \quad y = 500 t - 16 t^2,$$

$x$  and  $y$  being in feet. Plot the path.

$$\text{At } t = 5; \quad x = 5000, \quad y = 2500 - 400;$$

and similarly for the other values in the following table.

$t$	$x$	$y$	$t$	$x$	$y$
0	0	0	20	20000	3600
5	5000	2100	25	25000	2500
10	10000	3400	30	30000	600
15	15000	3900			

Plotting these points  $(x, y)$ , we draw the path smoothly. (Fig. 87.)

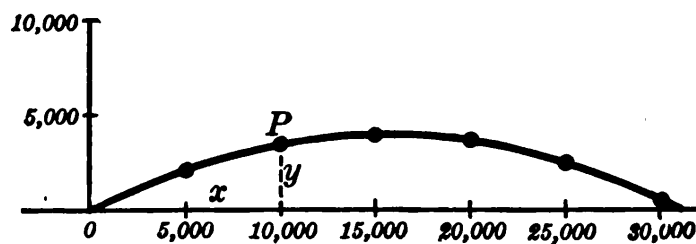

FIG. 87.

*Remark.* The projectile was highest when  $y$  was a maximum, or  $dy/dt=0$ :

$$500 - 32t = 0, \quad t = \frac{500}{32} = 15\frac{1}{4}.$$

It struck the ground when its height  $y$  became zero:

$$500t - 16t^2 = 0 \quad \text{or } t = 500/16 = 31\frac{1}{4}.*$$

The projectile struck at a point where  $x = 1000(31\frac{1}{4}) = 31,250$ .

### EXERCISES

1. Plot the points (0, 0) and (6, 8), and join. Calculate the slope of the line; also its inclination angle, and its length.

✓ 2. A city is laid out in squares, 10 to the mile. Map the following points:  $A(0, 0)$ ;  $B(10, 23)$ ;  $C(20, 15)$ ;  $D(22, -15)$ ;  $E(-5, -12)$ ;  $F(-24, -7)$ ;  $G(-18, 17)$ . (The  $X$ -axis points east, and the  $Y$ -axis north.) How long a wire would be needed to reach from  $A$  to  $E$ ? Which plotted points are inside the  $2\frac{1}{4}$  mile circle about  $A$ ? Of points on this circle, which is nearest  $A$ , via the streets? What direction is  $F$  from  $A$ ? How far is  $C$  from  $F$  by a straight subway? In what direction?

✓ 3. A gun is located at (4000, 5000) and a target at (16,000, 12,000) meters. Find the distance and direction. (The  $X$ -axis points east and the  $Y$ -axis north.)

4. The same as Ex. 3 for a gun at (2000, -3000) and target at (-1500, 9500).

✓ 5. Referred to  $X$ - and  $Y$ -axes pointing east and north from Soissons, the coördinates of several cities and towns (in miles) are: Rheims (32, -8); Laon (13, 13); St. Quentin (-2, 32); Cantigny (-37, 19); Paris (-44, -36); Château-Thierry (4, -23). Map these points. Measure the direct distance of Paris from Cantigny; from Château-Thierry. Calculate the latter.

6. The curve of a ship's deck near the stern passes through the points shown in Table I. Plot the curve on the scale of 1 inch to 2 ft. each way. (Run the  $Y$ -scale from 10 to 24 only.) By measurement, how long is the plotted curve?

7. The cross-section of a ship's hull at one of the stern bulkheads is a curve passing through the points shown in Table II. (All the abscissas are to be taken both positive and negative.) Draw the curve. Find the approximate area of the bulkhead, from the flat bottom up to the 30 ft.-level.

\* Observe that  $t=0$  also satisfies the equation. What does this mean?

8. The same as Ex. 7 for a bow bulkhead, using Table III. Find the area from the curved bottom up to the 35 ft. level.

9. The positions  $(x, y)$  of a moving point after various intervals ( $t$  sec.) are shown in Table IV. Draw the path.

TABLE I		TABLE II		TABLE III		TABLE IV		
$x$	$y$	$\pm x$	$y$	$\pm x$	$y$	$t$	$x$	$y$
0	19.85	.6	0	0	0	0	0	0
2.25	20.50	2.0	5	5	1.5	1	.6	.2
4.5	21.10	3.2	10	8.3	5	2	2.4	1.6
6.75	21.65	5.2	15	10.6	10	3	5.4	5.4
9.	22.15	8.7	20	11.9	15	5	15.0	25.0
11.25	22.60	13.8	25	12.8	20	7	29.4	68.6
13.5	23.00	18.3	30	13.7	25			
15.75	23.35	20.1	33.5	14.7	30			
18.	23.65			15.8	35			
				16.9	38.5			

10. A batted ball traveled thus:  $x = 120t$ ,  $y = 160t - 16t^2$ , the  $X$ -axis being horizontal and the  $Y$ -axis vertical. Calculate its position at various instants from  $t=0$  to  $t=10$ . Plot the path, using the same scale both ways. Measure the distance traveled through the air.

11. In Ex. 10 find when the ball was highest; also where it struck the ground.

**§ 188. Speed and Direction of Motion.** From a pair of "equations of motion," we can find not only where the moving point will be at any time, but also *how fast it will be moving*, and *in what direction*.

Consider, for instance, the projectile  $P$  in Ex. I, § 187:

$$x = 1000t, \quad y = 500t - 16t^2.$$

The rate at which its height  $y$  is increasing at any time is the rate at which  $P$  is then rising. That is,

$$\text{vertical speed} = \frac{dy}{dt} = 500 - 32t.$$

*E.g.*, at  $t=10$ ,  $P$  will be rising at the rate of  $500 - 320$ , or 180, ft./sec.

Similarly, since  $dx/dt = 1000$ ,  $P$  will be moving horizontally at the rate of 1000 ft./sec. (Fig. 87.)

In reality the motion of  $P$  will be neither horizontal nor vertical. But it is convenient to regard the *actual* motion as composed of two independent motions, in the  $X$  and  $Y$  directions.

If we draw directed lines or "vectors" to represent on some scale these two rates of motion, or "component speeds," then the *actual* speed and direction of motion will be represented by the diagonal of the rectangle:

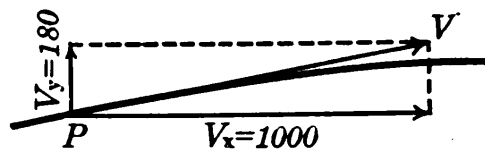

FIG. 88.

$$\therefore v = \sqrt{1000^2 + 180^2} = 1016+, \quad \tan A = \frac{180}{1000} = .18.$$

By tables,  $A = 10^\circ 12'$ . Thus at  $t = 10$ ,  $P$  was moving with a speed of 1016 ft./sec., in a direction  $10^\circ 12'$  above horizontal.

If the two component speeds were maintained for one second, the point  $P$  would move as just calculated, throughout the second.

**§ 189. General Formulas.** Let  $v_x$  and  $v_y$  denote the speeds of any moving point  $(x, y)$  in the  $X$  and  $Y$  directions, respectively, at any instant. Then, reasoning as in § 188, the actual speed and direction of motion are given by

$$v = \sqrt{v_x^2 + v_y^2}, \tag{1}$$

$$\tan A = v_y/v_x. \tag{2}$$

That is, the actual speed and direction are represented by the diagonal of a rectangle whose sides, drawn from the same vertex, represent  $v_x$  and  $v_y$ .\*

**§ 190. Distance Traveled.** Knowing the speed  $v$  of a moving object at every instant, we can find by integration

\* A formal mathematical proof of formulas (1) and (2) is given in the Appendix, p. 486.

the distance  $s$  traveled during any interval of time. For by (B), § 99:

$$s = \int v dt.$$

To illustrate, suppose that an object moves thus:

$$x = t^2, \quad y = \frac{1}{3} t^3 - t.$$

$$\text{Then } v_x = 2t, \quad v_y = t^2 - 1,$$

and by (1) above the speed at any time is

$$v = \sqrt{(2t)^2 + (t^2 - 1)^2} = \sqrt{t^4 + 2t^2 + 1} = t^2 + 1.$$

Hence the distance traveled is

$$s = \int v dt = \int (t^2 + 1) dt = \frac{1}{3} t^3 + t.$$

The constant of integration is zero since  $s = 0$  at  $t = 0$ .

*N.B.* The value of  $v$  which we must integrate in any case is the *general value in terms of  $t$* , and not the numerical value at some one instant.

### EXERCISES

1. A projectile moved thus:  $x = 1500t$ ,  $y = 400t - 16t^2$ . Plot the path. Measure the approximate distance traveled. Check the direction of motion at  $t = 5$  by calculating  $v_x$  and  $v_y$  and drawing the corresponding vectors on the graph as in Fig. 88.

2. A bullet traveled thus:  $x = 800t$ ,  $y = 600t - 16t^2$ . Plot the path. Find  $v_x$  and  $v_y$  at  $t = 5$ , and also at  $t = 0$ . Represent by vectors; and calculate the actual speed and direction in each case.

3. In Ex. 2 find when and where the bullet struck the ground, — and with what speed and inclination.

4. A point moved thus:  $x = 3t^2$ ,  $y = 3t - t^3$ . Plot its path from  $t = -4$  to  $t = 4$ . Calculate  $v_x$ ,  $v_y$ , at  $t = 2$ ; also the actual speed and direction then. Illustrate by vectors.

5. In Ex. 4 find  $v$  at any time. Also find the exact distance traveled from  $t = 0$  to  $t = 4$ ; and check by measurement.

6. A point moved thus:  $x = 9t^2$ ,  $y = t^3$ . Find the distance traveled in the first  $t$  sec. (Hint: Show that  $v = 3t\sqrt{t^2 + 36}$ , and integrate as in § 101.)



7. In each of the following, calculate the position of the moving point at several instants during the specified interval, and plot the path. Also find the speed and direction of motion at  $t=2$ , and show this on the plotted path.

(a)  $x=3t^2$ ,  $y=2t^3$ , from  $t=0$  to  $t=4$ .

(b)  $x=t^2-2t$ ,  $y=\frac{1}{3}t^{\frac{3}{2}}$ , from  $t=0$  to  $4$ .

(c)  $x=6(12-t^2)$ ,  $y=t(12-t^2)$ , from  $t=-4$  to  $+4$ .

(d)  $x=20t(t^2-4)$ ,  $y=20t^2(t^2-4)$ , from  $t=-2.5$  to  $+2.5$ , every  $.5$ .

(e)  $x=t^2(t-4)$ ,  $y=t^3(t-4)$ , from  $t=-1$  to  $+5$ .

8. (a), (b), (c). Calculate the lengths of the paths plotted in Ex. 7 (a), (b), (c). Check by measurement.

**§ 191. Deriving the Equations of Motion.** The foregoing methods of studying motion exactly can be used only when we know the "equations of motion," which give  $x$  and  $y$  in terms of  $t$ . The question therefore arises as to how such equations are obtained in the first place.

The method is different in different cases. Sometimes the equations are discovered experimentally, the position of the moving object being observed at various times, and a formula being devised to fit the resulting table. But usually the equations are deduced mathematically from some physical or mechanical principle which governs the motion. A good example is the motion of a projectile, or other object, fired or thrown in any way.

If we ignore air resistance, there is no horizontal acceleration, and the vertical acceleration is  $-32$  (ft./sec.<sup>2</sup>).\* That is,

$$\frac{d^2x}{dt^2} = 0, \quad \frac{d^2y}{dt^2} = -32. \quad (3)$$

Integrating both of these twice gives the desired equations, the constants of integration being determined by the way the projectile is fired.

Some further types of motion, equally important, will be discussed later.

\* See Remark I, p. 43.

Ex. I. Find the equations of motion for a projectile fired with a speed of 1000 ft./sec. at an inclination of  $30^\circ$ .

Integrating (3):

$$\frac{dx}{dt} = c, \quad \frac{dy}{dt} = -32t + c', \quad (4)$$

$$x = ct + k, \quad y = -16t^2 + c't + k'. \quad (5)$$

If we have chosen our axes so as to pass through the firing point, then  $x=0$  and  $y=0$  at  $t=0$ . Hence  $k=0$ ,  $k'=0$ . To

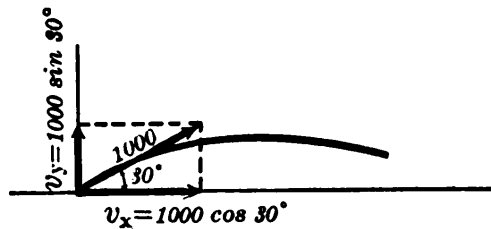

FIG. 89.

determine the values of  $c$  and  $c'$ , observe in (4) that these constants are simply the values of  $dx/dt$  and  $dy/dt$  (i.e., the component speeds  $v_x$  and  $v_y$ ) at  $t=0$ . By Fig. 89 these are simply:

$$v_x = 1000 \cos 30^\circ = 866.03,$$

$$v_y = 1000 \sin 30^\circ = 500.$$

Substituting these values of  $c$  and  $c'$  gives finally

$$x = 866.03 t, \quad y = 500 t - 16 t^2. \quad (6)$$

*Remarks.* (I) These equations could now be used to study the motion in detail. The general shape of the path could be seen by plotting, as in § 187. Its precise geometrical character can be determined later. (§ 223.)

(II) If the projectile were fired from an airplane 2000 ft. high, directly above our origin (0, 0), we should still have  $k=0$ , but  $k'=2000$ .

### EXERCISES

1. A projectile was fired with a speed of 1500 ft./sec. and an inclination of  $21^\circ 6'$ . Find its equations of motion, ignoring resistance.

2. When and where did the projectile in Ex. 1 strike the ground? With what speed and inclination was it then moving?

3. The same as Ex. 1 for a ball thrown with a speed of 100 ft./sec and an inclination of  $30^\circ$ . Also find when and where it was highest.

4. A golf ball, driven with a speed of 125 ft./sec. and an inclination of  $.40^\circ$ , over level ground, rolled 100 ft. after striking. Find the equations of motion before striking, and the total length of the "drive."

[5.] Plot the points (3, 1) and (12, 13). Calculate their distance apart. Can you derive a formula for the distance from (3, 1) to any other point  $(x, y)$ ? From  $(x, y)$  to  $(x', y')$ ?

[6.] Is the quadrilateral whose vertices are (1, 19), (23, 2), (88, 34), (66, 52) a parallelogram? Plot, but also make a sure test by calculating slopes.

### (B) ANALYTIC GEOMETRY

§ 192. **Formulas Needed.** Coördinates are useful not only in mapping points and studying motion, but also in studying geometry. The first step in this direction is to derive certain standard formulas for distances, slopes, etc., by which those quantities can be calculated immediately without the necessity of drawing a figure. These formulas should be carefully memorized.

In deriving the formulas we shall denote any two given fixed points by  $(x_1, y_1)$  and  $(x_2, y_2)$ . Here  $x_2$  (read "x two") means simply the  $x$  of the second point. Do not confuse it with  $x^2$ .

§ 193. **Distance Formula.** The distance between any two points  $(x_1, y_1)$  and  $(x_2, y_2)$  is seen from Fig. 90 to be

$$d = \sqrt{(x_2 - x_1)^2 + (y_2 - y_1)^2}. \quad (7)$$

For  $d$  is the hypotenuse of a right triangle, whose legs are the difference of the  $x$ 's and the difference of the  $y$ 's.\*

Ex. I. The distance between (2, 3) and (8, 15) is by (7):

$$d = \sqrt{(8 - 2)^2 + (15 - 3)^2} = \sqrt{180}.$$

*Remarks.* (I) It makes no difference which point is considered as  $(x_1, y_1)$  and which as  $(x_2, y_2)$ . *E.g.*,  $(2 - 8)^2$  equals  $(8 - 2)^2$ .

(II) Formula (7) is correct even when some of the coördinates are negative. *E.g.*, for the points  $(-4, -10)$  and  $(-24, 6)$ , (7) gives

$$d = \sqrt{(-24 + 4)^2 + (6 + 10)^2} = \sqrt{20^2 + 16^2},$$

\* The formula may also be written  $d = \sqrt{\Delta x^2 + \Delta y^2}$ .

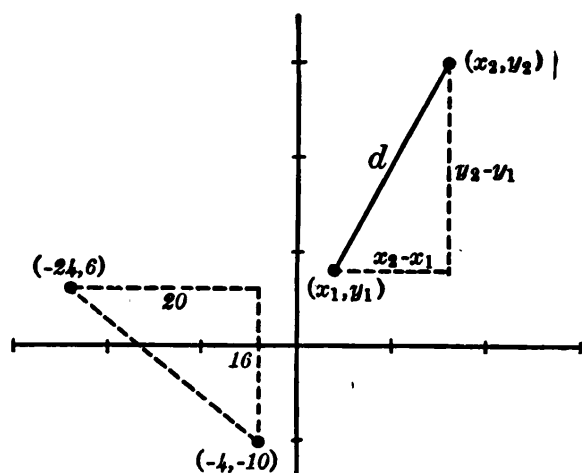

FIG. 90.

which agrees with Fig. 90 where the legs of the right triangle are 20 and 16.

### § 194. Slope Formula.

The slope of the line joining  $(x_1, y_1)$  and  $(x_2, y_2)$  is

$$l = \frac{y_2 - y_1}{x_2 - x_1}. \quad (8)$$

For the line rises  $(y_2 - y_1)$  units in  $(x_2 - x_1)$  horizontal units.

Ex. I. The slope of the line through  $(3, 4)$  and  $(8, 10)$  is

$$l = \frac{10 - 4}{8 - 3} = \frac{6}{5}.$$

(This is simply the difference of the  $y$ 's divided by the difference of the  $x$ 's, or  $\Delta y / \Delta x$ .)

*Remarks.* (I) The order of subtraction must not be reversed for  $x$  or  $y$  alone.

(II) Formula (8) is correct even when the line *descends* toward the right. For instance, for the line from  $(-24, 6)$  to  $(-4, -10)$  in Fig. 90, the formula gives  $l = (-10 - 6) \div (-4 + 24)$  or  $-\frac{16}{20}$ , which agrees with the figure.

§ 195. **Mid-point Formula.** The point  $(\bar{x}, \bar{y})$  midway between  $(x_1, y_1)$  and  $(x_2, y_2)$  is:

$$\bar{x} = \frac{1}{2}(x_1 + x_2), \quad \bar{y} = \frac{1}{2}(y_1 + y_2). \quad (9)$$

For the vertical line through  $(\bar{x}, \bar{y})$  bisects the base, and equals half the height, of the right triangle shown in Fig. 91. (Why?) That is,

$$\bar{x} - x_1 = \frac{1}{2}(x_2 - x_1), \quad \bar{y} - y_1 = \frac{1}{2}(y_2 - y_1),$$

which, simplified, reduce to the formulas in (9).

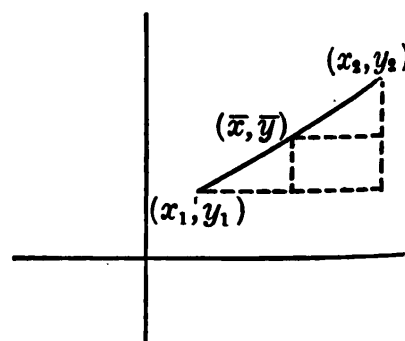

FIG. 91.



9. In the triangle whose vertices are (13, 4), (19, 12), and (7, -8) show that the line joining the mid-points of any two sides is parallel to the third side, and equal to half of it.

10. The same as Ex. 9 for the triangle (1, 8), (9, -2), (15, 6).

(*N.B.* Draw figures in the following exercises, but also use some sure test.)

11. What sort of triangle is it whose vertices are (10, 35), (25, 15), and (73, 51)? Can you find the area of this triangle?

12. What sort of quadrilateral has the vertices (-10, 40), (10, 10), (43, 32), and (23, 62)? Find the lengths of the diagonals.

13. A triangle has vertices (2, 48), (51, 61), and (38, 12). What is its perimeter? Is it equilateral?

14. Find the length of the medians of the triangle whose vertices are (1, 8), (9, -2), and (15, 6).

15. A triangle has vertices (4, 2), (8, 5), and (11, 1). Is it isosceles? Equilateral? A right triangle? (Test by the lengths of the sides and also by their inclinations.)

16. A quadrilateral has vertices (3, 1), (15, 9), (17, 6), and (5, -2). Is it a parallelogram? A rectangle? (Test the diagonals.)

17. Certain buildings in a city are located as follows: City Hall,  $A$  (0, 0); Post Office,  $B$  (3, 2); Court House,  $C$  (-1, 6); railroad stations,  $D$  (15, 9) and  $E$  (3, 11). Plot. A garage is to be built midway between  $D$  and  $E$ , and a law library midway between  $A$  and  $C$ . What locations? How far is  $B$  from  $C$ ,  $D$ , and  $E$  in air-lines?

18. A boulevard joining the points (5, 2) and (12, 7) is crossed by a railroad from (15, 9) to (6, -12). What is the angle of crossing?

19. In a certain county there are several towns located as follows:  $A$  (0, 0),  $B$  (8, 7),  $C$  (-3, 9),  $D$  (1, -11), the unit being 1 mi. and the axes certain section lines, with  $OX$  pointing east. How far are  $B$ ,  $C$ , and  $D$  from  $A$  by airplane, and in precisely what directions? If straight railways join  $AD$  and  $BC$ , at what angle will they cross?

20. A town located at (0, 0) gets its water from a reservoir at (14, 5). How long is the water main, allowing 10% extra for grades?

**§ 197. Test for Perpendicularity.** Suppose that two lines are perpendicular, and that one rises at an angle of  $40^\circ$ . Then the other must fall at an angle of  $50^\circ$ . (Fig. 92.) Hence the two slopes are

$$l_1 = \tan 40^\circ, \quad l_2 = -\tan 50^\circ.$$

But  $\tan 50^\circ = \text{ctn } 40^\circ$ ; hence  $l_2 = -\text{ctn } 40^\circ, = -1/\tan 40^\circ$ . (§ 111.) That is,

$$l_2 = -\frac{1}{l_1}. \tag{10}$$

Hence, for these two perpendicular lines, *the slope of one is the negative reciprocal of the slope of the other.*

Moreover, this is true for *any* pair of perpendicular lines.\* No matter at what angle  $A_1$  one line ascends, the other must descend at an angle  $A_2$  which is the *complement* of  $A_1$ . Thus the same reasoning applies as above :

$$l_1 = \tan A_1, l_2 = -\tan A_2 = -\text{ctn } A_1 = -1/l_1.$$

Hence if one of two perpendicular lines has the slope 3, the other must have the slope  $-\frac{1}{3}$ . If one has the slope  $-\frac{2}{3}$ , the other must have the slope  $+\frac{3}{2}$ .

Conversely: if  $l_2 = -1/l_1$ , the lines must be perpendicular. For the perpendicular to the first line at the common point would have its slope equal to  $-1/l_1$ , and would have to coincide with the second line, since there can be only one line through a given point with a given slope.

**§ 198. Equation and Locus.** A sure test whether a point  $(x, y)$  is on the circle with center  $(0, 0)$  and radius 10 (Fig. 93) is to see whether

$$x^2 + y^2 = 100. \tag{11}$$

This equation is true for any point on the circle, no matter where taken. But it is not true for points inside or outside the circle.

Similarly, a sure test whether a point lies on any other curve or line, say an ellipse or spiral or straight line, is to see

\* Except a horizontal and a vertical line. The latter has no such thing as a "slope," strictly speaking. See § 41.

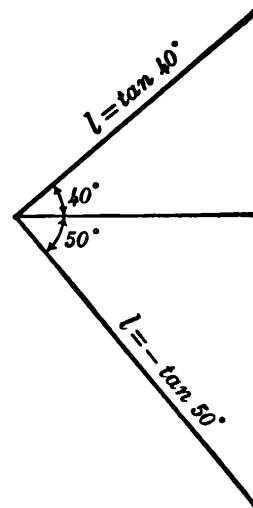

FIG. 92.

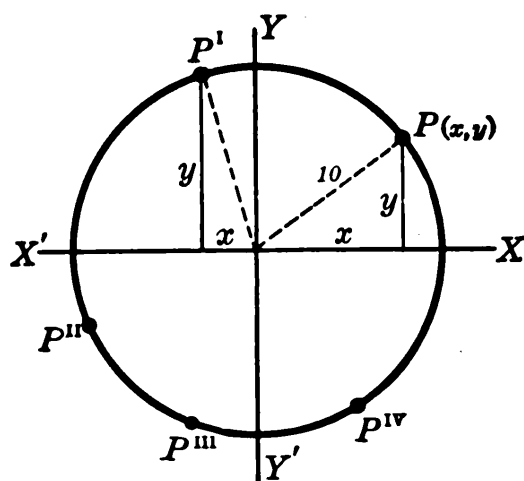

FIG. 93.

whether some other definite equation is true for the  $x$  and  $y$  of the point. Along any graph, for instance, there is some definite relation  $y=f(x)$ .

*Definition.* An equation which is true for the coördinates of any point on a curve, but not true for the coördinates of any other point, is called *the equation*

*of the curve.* And the curve is called the *locus* of the equation.

*E.g.*, (11) is the equation of the circle in Fig. 93. And that circle is the locus of equation (11). We have already plotted the loci of many other equations, — such as  $y=x^2$ ,  $y=x^3-12x+5$ , etc.

**§ 199. Descartes' Great Invention.** The fact that any one equation *belongs exclusively to some particular curve* makes possible the solution of many geometrical problems by means of coördinates.

**ILLUSTRATION.** If a point  $(x, y)$  moves in such a way that its distance from  $(20, 0)$  is always twice its distance from  $(5, 0)$ , along what curve will it move?

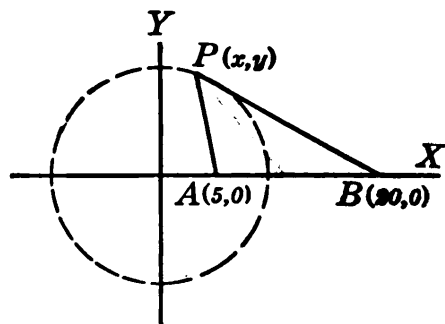

FIG. 94.

By hypothesis we have continually, in Fig. 94,

$$BP=2AP.$$

Expressing  $BP$  and  $AP$  in terms of coördinates by the standard distance formula (7), p. 279,

$$\sqrt{(x-20)^2+(y-0)^2}=2\sqrt{(x-5)^2+(y-0)^2}.$$



Simplifying by squaring and collecting terms :

$$\begin{aligned}x^2 - 40x + 400 + y^2 &= 4(x^2 - 10x + 25 + y^2), \\ 3x^2 + 3y^2 &= 300.\end{aligned}$$

That is,  $P$  must move in such a way that  $x^2 + y^2 = 100$  continually. But by (11), p. 283, all points for which this is true lie on a certain circle. (Fig. 93.) Hence  $P$  must move along that circle.

This fact can also be proved by elementary geometry; but some ingenuity is required to know what construction lines to introduce. (Do you see what lines?)

Observe that in solving this problem by the coördinate method, we had only to express by a standard formula the given fact that  $BP = 2AP$ , and then simplify according to the standard rules of algebra. Much more difficult problems can be handled easily by this method as soon as we are familiar with the standard equations of certain curves, and can recognize the equations at sight.

Coördinates were invented by René Descartes, a Frenchman, who published in 1637 a systematic treatment of geometry by means of coördinates and equations. This was a great step in advance, for the method is so systematic and powerful that it permitted a tremendous extension of higher geometry. In particular, the problem at once arose of finding the direction of any curve at any point; and this soon led to the invention of calculus by Newton and Leibnitz. (Cf. § 103.)

Geometry thus studied is called "analytic" or "coördinate" or "Cartesian" geometry, — Cartesius being the Latin form of Descartes' name.

### EXERCISES

1. Is the line joining (1, 4) and (9, 8) perpendicular to the line joining (3, 14) and (13, -6)?
2. A triangle has vertices (1, 3), (15, -5), and (11, 7). Is the median from the last vertex perpendicular to the side joining the first two?

3. The vertices of a quadrilateral are  $(4, 2)$ ,  $(16, 10)$ ,  $(6, -1)$ , and  $(18, 7)$ . Is it a rectangle? Are the diagonals perpendicular?

4. The vertices of a quadrilateral are  $(4, 5)$ ,  $(10, 15)$ ,  $(40, 1)$ , and  $(8, -7)$ . Show that the lines joining the mid-points of its four sides form a parallelogram.

5. Where are all the points for which  $y=x$ ?  $y=3x$ ?  $y=-x$ ?  $y=9$ ?  $x=4$ ?  $x^2+y^2=1$ ?  $x^2+y^2=25$ ?

6. Which of the points  $(7, 24)$ ,  $(21, 15)$ ,  $(16, 20)$  are on the curve  $x^2+y^2=625$ ? At what points on this curve is  $x=-20$ ?

7. Which of the points  $(10, -10)$ ,  $(6, 5)$ , and  $(50, 30)$  are on the curve  $y^2=20(x-5)$ ? Where does this curve meet the  $X$ -axis? (Hint: What is the value of  $y$  at any such point?)

8. At what points of the curve  $4y^2=x^3$  is  $y=x$ ?

9. Where does the curve  $x^2+y^2=25$  cross the vertical line 3 units to the left of the  $Y$ -axis? Where does it cross the line bisecting the angle between the negative  $X$  and  $Y$  axes?

10. What value must  $r$  have if the curve  $x^2+y^2=r^2$  is to pass through the point  $(3, -4)$ ?

11. Is the point  $(8, 6)$  on the circle  $x^2+y^2=100$ ? Find the slopes of the lines joining it to the ends of the horizontal diameter. What theorem of geometry is illustrated?

12. A square has its vertices at  $(5, 5)$ ,  $(5, -5)$ ,  $(-5, -5)$ , and  $(-5, 5)$ . A point  $(x, y)$  moves so that the sum of the squares of its distances from these vertices is always 300. Find its path.

13. A point  $(x, y)$  moves so that its distance from  $(50, 0)$  is always 5 times its distance from  $(2, 0)$ . Find its path. Check the points where it crosses the  $X$ -axis.

14. A point  $(x, y)$  moves so that the sum of the squares of its distances from  $(-3, 0)$  and  $(3, 0)$  is always 50. Find its path. Check as in Ex. 13.

15. A point  $(x, y)$  moves so that the lines joining it to  $(8, 0)$  and  $(-8, 0)$  are always perpendicular. Find the path.

[16.] Express by an equation the fact that a point  $(x, y)$  is on the circle with center  $(9, 8)$  and radius 13.

§ 200. **Linear Equations.** If an equation is of the first degree, — *i.e.*, of the form

$$ax + by + c = 0, \quad (12)$$

where  $a$ ,  $b$ , and  $c$  are constants, its locus is a straight line.

PROOF. (I) If  $b$  is not zero, so that  $y$  is actually present, we can solve for  $y$ , getting an equation of the form

$$y = lx + k, \quad (13)$$

where  $l$  and  $k$  are some constants (viz.,  $l = -a/b$ ,  $k = -c/b$ ). Differentiating this:

$$\frac{dy}{dx} = l, \text{ constant.}$$

That is,  $y$  increases at a constant rate, and its graph (or the required locus) must be straight (§ 7). In other words the locus has a constant slope; and all points for which the equation is true lie along a straight line. Conversely, by § 32 the coördinates of all points on the line satisfy one and the same linear equation.

(II) If  $b$  happens to be zero, so that  $y$  is missing, equation (12) gives simply  $x = -c/a$ . All points at which  $x$  has this constant value lie on a certain straight line parallel to the  $Y$ -axis. And for all points on that line  $x$  has the value  $-c/a$ .

Hence, whether  $b = 0$  or  $b \neq 0$ , the locus of (12) is a straight line.

To find the slope of a line whose equation is given, we simply think of the equation as thrown into the form (13). The coefficient of  $x$  will then be  $l$ , the slope.

To draw a line from its equation, we simply calculate two points, well separated, and join them. A third point should be calculated as a check.

Ex. I.  $2x + 3y + 5 = 0$ . Here  $y = -\frac{2}{3}x - \frac{5}{3}$ .  $\therefore$  Slope =  $-\frac{2}{3}$ .

Ex. II.  $4x - 7y = 8$ . Here  $y = \frac{4}{7}x - \frac{8}{7}$ .  $\therefore$  Slope =  $\frac{4}{7}$ .

### EXERCISES

1. Can a point move and yet keep  $x = 5$  constantly? How? Or  $y = -3$  constantly? Draw the lines  $x + 11 = 0$ ,  $2x + 7 = 0$ ,  $y^2 = 9$ .
2. Draw the following straight lines, checking each by calculating a third point:  $x = y$ ,  $x + y = 5$ ,  $2x + 3y - 18 = 0$ ,  $4x + y + 11 = 0$ .

3. Draw the following lines with a single pair of axes, checking each:

$$y = x + 5, \quad y = \frac{1}{2}x + 5, \quad y = 3x + 5, \quad y = 2x + 5.$$

Note how the constant 5 appears in the lines.

4. The same as Ex. 3 for the lines:  $y = 2x + 7$ ,  $y = 2x - 1$ ,  $y = 2x + 3$ ,  $y = 2x$ . Note the constant 2.

5. What is the geometrical significance of  $a$  and  $b$  in the equation  $y = ax + b$ ? Compare Exs. 3-4.

6. What slope has each of these lines:

$$2x + 5y = 7, \quad 3x - 4y + 9 = 0, \quad x - y - 5 = 0?$$

Draw the lines.

7. Is the line  $2x - 3y + 5 = 0$  perpendicular to the line joining  $(1, 9)$  and  $(5, -3)$ ? Does it pass through the point midway between these two?

8. A point  $(x, y)$  moves so that its distances from  $(1, 3)$  and  $(9, -1)$  are always equal. (A) Find the equation of its path, simplified. (B) Show that the path is perpendicular to, and bisects, the line joining the given points.

9. Show analytically that the locus of points equidistant from  $(3, 2)$  and  $(7, -4)$  is the perpendicular bisector of the line joining these points.

10. A point moves so that the sum of its distances from the  $X$  and  $Y$  axes is constantly 10. Draw its path. (Is this properly an unlimited line? Discuss.)

11. How far is the point  $(13, 7)$  from the line along which  $x = -3$ ? Likewise the point  $(6, 1)$ ? Likewise any point  $(x, y)$ ? How far is  $(x, y)$  from the lines  $x = -8$ ,  $y = -4$ , and  $y = 7$ ?

**§ 201. Type Equation of a Circle.** Let  $(h, k)$  denote the center and  $r$  the radius of any circle. Then for any point  $(x, y)$  on the circle, and for no other points, we have by the distance formula:

$$(x - h)^2 + (y - k)^2 = r^2. \quad (14)$$

This is therefore the general equation for any circle. Observe that the coördinates of the center are *subtracted* from  $x$  and  $y$ , — not added to them.

Ex. I. For a circle with center  $(5, 2)$  and radius 7, the equation is

$$(x - 5)^2 + (y - 2)^2 = 49.$$

Ex. II. Find the equation of the circle having (8, 3) and (4, -5) as ends of a diameter.

The center is the mid-point (6, -1); and the radius is the distance from (6, -1) to (8, 3) or (4, -5), viz.,  $\sqrt{20}$ . The equation is

$$(x-6)^2 + (y+1)^2 = 20.$$

§ 202. **Drawing a Circle from Its Equation.** In case a given equation represents a circle, we can easily recognize that fact, and determine the center and radius, by comparing the given equation with the type equation (14). The circle can then be drawn with the compasses.

Ex. I. Draw the locus of

$$(x-8)^2 + (y+6)^2 = 400.$$

This is a case of

$$(x-h)^2 + (y-k)^2 = r^2,$$

in which  $h=8$ ,  $k=-6$ ,  $r=20$ . Hence, the locus is the circle with center (8, -6) and radius 20. (Fig. 95.)

Ex. II. Find the locus of

$$2x^2 + 2y^2 + 10x + 7y - 10 = 0.$$

Dividing through by 2 and completing both squares gives

$$(x^2 + 5x + \frac{25}{4}) + (y^2 + \frac{7}{2}y + \frac{49}{16}) = 5 + \frac{25}{4} + \frac{49}{16};$$

i.e.,

$$(x + \frac{5}{2})^2 + (y + \frac{7}{4})^2 = \frac{229}{16}.$$

This represents a circle: center  $(-\frac{5}{2}, -\frac{7}{4})$ ; radius,  $\sqrt{229}/4$ .

Ex. III. Is the locus of  $2x^2 + 3y^2 - 5x = 7$  a circle?

No; for this equation cannot be reduced to the type equation (14), — in which the coefficients of  $x^2$  and  $y^2$  are both 1. (At present we could plot the locus only by calculating points; later we shall be able to recognize precisely what curve it is.)

*Remark.* The only terms which can appear in the type equation (14) when multiplied out are:  $x^2 + y^2$ , with a common coefficient;  $x$  and  $y$ ,

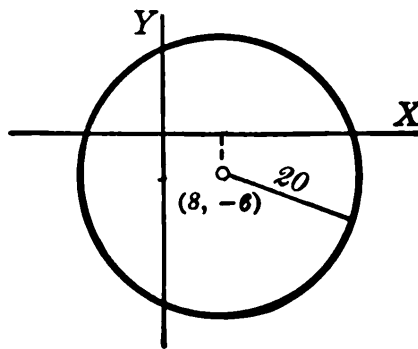

FIG. 95.

with any coefficients, and a constant term. (The product  $xy$  cannot occur, nor  $x^2 - y^2$ , nor higher powers.) Thus we can tell at a glance whether any given equation represents some circle.

## EXERCISES

1. Write the equations of the circles which have the following centers and radii:  $(5, 12)$ ,  $r=11$ ;  $(-3, -4)$ ,  $r=5$ ;  $(2, 0)$ ,  $r=3$ .
2. Find the equations of the following circles:
  - (a) With center  $(1, 2)$ , and passing through the point  $(7, -6)$ ;
  - (b) With center midway between  $(2, 9)$  and  $(8, -1)$ , and passing through  $(1, 1)$ ;
  - (c) Having the line joining  $(4, 4)$  and  $(-8, 2)$  as a diameter.
3. What are the centers and radii of:  $(x-8)^2 + (y+3)^2 = 9$ ;  $(x+4)^2 + y^2 = 25$ ;  $x^2 + (y-1)^2 = 1$ ? Draw each circle by compasses.
4. Find the centers and radii of the circles  $x^2 + y^2 + 16x - 30y = 0$ ;  $x^2 + y^2 - 12x - 10y + 12 = 0$ . Draw the circles.
5. The same as Ex. 4 for the circles  $2x^2 + 2y^2 - 12x - 15y = 0$ , and  $3x^2 + 3y^2 + 10x = 8$ .
6. A point  $(x, y)$  moves so that the sum of the squares of its distances from  $(-6, 0)$  and  $(6, 0)$  is 200. Find the equation, and draw the path. Select some special point on the curve and verify that it fulfills the specified requirement.
7. A point moves so that the sum of the squares of its distances from  $(3, 0)$  and  $(-3, 0)$  is any constant  $k$ . Find the character of its path. Draw the path when  $k=22$  and when  $k=34$ . In each case check for some point.
8. A point moves so that its distance from  $(12, 0)$  is always twice its distance from  $(0, 0)$ . Find the equation of its path; plot, and check for some point.
9. In an "Addition" to a certain city a boulevard is to run east to a point  $(12, 8)$ , then swing around a quarter circle and run south from  $(17, 3)$ . What center and radius must the curved arc have? What equation? Where will the curve meet a street on which  $x=15$ ?
10. The same as Ex. 9 if the curve starts at  $(10, 18)$  and ends at  $(17, 11)$ .
11. Draw circles with centers  $(0, 0)$  and  $(12, 16)$  and passing through  $(30, 40)$ . Find their equations. How much higher is the first at  $x=0$  than the second at  $x=36$ ? Are they tangent? Reason?
12. The curve of the under side of a bridge consists of three circular arcs, as follows: (I) Center  $(0, 0)$ , connecting  $(56, 192)$  and  $(-56,$

192); (II) Center (14, 48), running from (56, 192) to  $x=104$ ; (III) Symmetrical with (II), on the left. Draw this compound curve. Show that the intersection (56, 192) is on the line of centers, making the arcs tangent.

13. In Ex. 12, calculate the radius of each circle and write each equation. Calculate the height of the arch at the middle, above the ends. Compare with your drawing.

14. Draw the circle  $x^2 + (y - 8)^2 = 25$ . How high above the  $X$ -axis are the two points at which  $x = 4$ ? If this circle were revolved about the  $X$ -axis, what sort of surface would be generated? How far would the center travel? Also the two points just mentioned?

15. Find by differentiation the slope of the tangent to the circle  $x^2 + y^2 = 100$  at the point (8, 6). Also find independently the slope of the radius drawn to (8, 6) and compare. What theorem is illustrated?

§ 203. **Choosing Axes.** In proving a geometrical theorem analytically we must first introduce axes. We select these, of course, in such a way as to make the equations and coördinates considered as simple as possible. When we wish to be general we use letters rather than special numbers for the coördinates of the given points. A couple of illustrations follow.

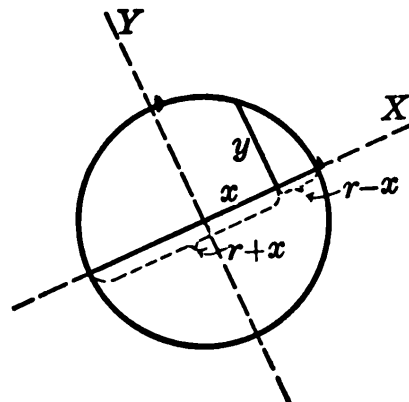

FIG. 96.

(I) **THEOREM:** *The perpendicular dropped from any point of a circle upon any diameter is a mean proportional between the segments of the diameter.*

**PROOF.** Choose the diameter in question as the  $X$ -axis, and the center of the circle as origin. Then the equation of the circle is simply  $x^2 + y^2 = r^2$ . The proposed perpendicular is simply  $y$ . (Fig. 96.) Hence we are to prove  $y$  a mean proportional between the segments of the diameter ( $r+x$ ) and ( $r-x$ ).

Now from the equation of the circle we have at once

$$y^2 = r^2 - x^2,$$

or

$$y^2 = (r+x)(r-x).$$

$$\therefore \frac{r+x}{y} = \frac{y}{r-x}. \quad (\text{Q. E. D.})$$

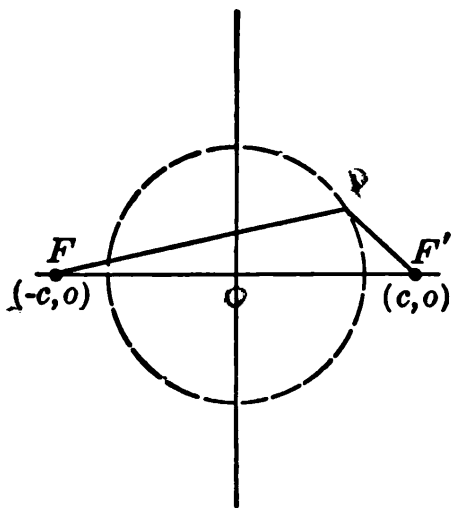

FIG. 97.

(II) PROBLEM: A point  $P(x, y)$  moves in such a way that the sum of the squares of its distances from two fixed points  $F$  and  $F'$  is constant. Along what curve does it move?

SOLUTION. Choose the line  $FF'$  as the  $X$ -axis, and the mid-point as the origin. Let  $c$  denote one half the distance between  $F$  and  $F'$ , whose coordinates are then simply  $(c, 0)$  and  $(-c, 0)$ . (Fig.

97.) Let  $k$  denote the constant sum of the squares:  $\overline{FP}^2 + \overline{F'P}^2$ . Then

$$[\sqrt{(x-c)^2 + y^2}]^2 + [\sqrt{(x+c)^2 + y^2}]^2 = k.$$

The radicals disappear, and the equation reduces to

$$x^2 + y^2 = k/2 - c^2.$$

The path is a circle with center midway between  $F$  and  $F'$ .

### EXERCISES

1. A point moves so that the sum of its distances from two mutually perpendicular lines is constant. Prove analytically that its path is a straight line. What if the *difference* of the distances were to be constant instead of the sum?

2. A point moves so that its distance from one of two perpendicular lines is twice its distance from the other. Find an equation for its path. Plot and verify several points. What if the two distances have any constant ratio?



3. Prove analytically that the middle point of the hypotenuse of any right triangle is equidistant from the three vertices.

4. Prove analytically that the diagonals of any rectangle are equal, but that they are perpendicular only if the rectangle is a square.

5. A point moves in such a way that the sum of the squares of its distances from two fixed points is constant. Prove analytically that it moves in a circle.

6. In Ex. 5 if the *difference* of the squares were constant instead of the sum, what would the path be?

7. A point moves so that its distances from two fixed points have a constant ratio. What sort of path? Any exception?

8. A point  $(x, y)$  moves so that the sum of the squares of its distances from the four sides of a square is constant. What sort of path?

[9.] A point  $(x, y)$  moves so that its distance from  $(3, 0)$  equals its distance from the line  $x = -3$ . (Cf. Ex. 11, p. 288.) Find the equation of its path.

[10.] From the answer to Ex. 9 calculate several points and plot. Then select several points on the curve and test by measurement whether they meet the requirement stated in Ex. 9.

§ 204. **The Parabola.** We proceed now to study a few plane curves other than circles, which are used frequently in scientific work.

*Definition:* A parabola is the locus of a point which is equidistant from a fixed straight line and a fixed point.

This means (Fig. 98) that any point  $P$  on the parabola is equidistant from the line  $DD'$  and the point  $F$ ; and also that every point thus equidistant is to be considered as part of the parabola. The fixed line  $DD'$  is called the *directrix*; and the fixed point  $F$  the *focus*.

Any number of points on a parabola can be found by simply drawing lines parallel to  $DD'$ , and cutting them by arcs described from  $F$  with the proper radii.

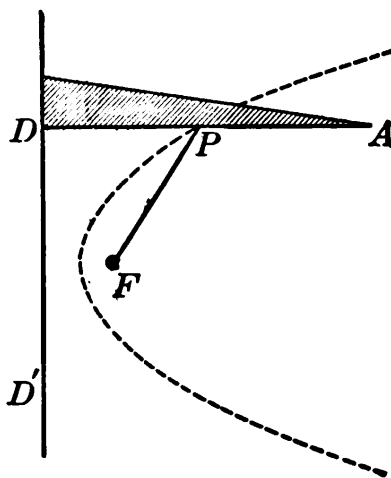

FIG. 98.

Or the parabola can be drawn *by continuous motion*. A triangular ruler (Fig. 98) slides along  $DD'$ , the edge  $DP$  being perpendicular to  $DD'$ . A string just long enough to reach from  $A$  to  $D$  has one end fastened to the ruler at  $A$ ; and the other end fastened at  $F$ . The pencil point  $P$  keeps the string taut, — that is, keeps  $FP = DP$ , while the ruler moves. Hence  $P$  travels along a parabola.

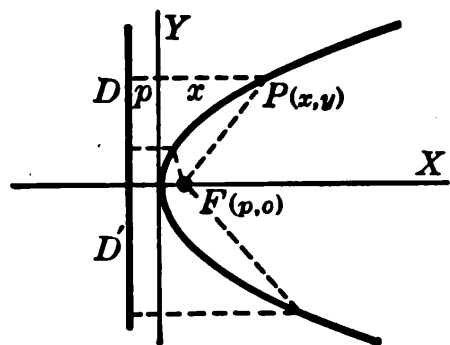

FIG. 99.

§ 205. **Type Equation.** Denote by  $2p$  the distance from  $F$  to  $DD'$ ; and choose axes as in Fig. 99, so that  $F$  has the coordinates  $(p, 0)$  and  $DD'$  is  $p$  units to the left of the  $Y$ -axis. Then for any point  $P(x, y)$ :

$$DP = x + p,$$

$$FP = \sqrt{(x - p)^2 + (y - 0)^2}.$$

At every point of the parabola, and at no others:  $DP = FP$ .

*I.e.,* 
$$x + p = \sqrt{(x - p)^2 + y^2}.$$

Simplified, this gives as the type equation of a parabola:

$$y^2 = 4px. \quad (15)$$

*E.g.,*  $y^2 = 15x$  is the equation of a parabola in which  $p = \frac{15}{4}$ . That is, the distance from directrix to focus is  $\frac{15}{4}$ .

§ 206. **Nature of a Parabola.** The general character of a parabola can be seen from its equation

$$y^2 = 4px.$$

(1) It does not extend to the left of  $(0, 0)$ . For  $x$  cannot be negative in the equation. (2) It extends *indefinitely far toward the right*. For  $y$  is real at all positive values of  $x$ . (3) It is *symmetrical with respect to the X-axis*. For there are always two values of  $y$ ,  $\pm$ , numerically equal. Consider, then, only the upper half of the curve. (4) It has *no highest*

point but rises continually. For  $y$  continually increases with  $x$ . (5) *Its slope, however, continually decreases.* For, differentiating gives

$$2y \frac{dy}{dx} = 4p, \quad \text{or} \quad \frac{dy}{dx} = \frac{2p}{y}, \quad (16)$$

which shows that  $dy/dx$  grows smaller as  $y$  increases. That is, although the curve continues to rise, it rises less and less rapidly. (6) *It makes no undulations.* For the slope reaches no maximum or minimum value.

The curve therefore appears as in Fig. 99. The axis of symmetry is called the *axis* of the parabola; and the point where this axis crosses the curve, the *vertex*. The rapidity with which the curve spreads apart depends upon the value of  $p$ . When

$$x = 1, \quad y = \pm \sqrt{4p}.$$

*N.B.* A curve may *look* very much like a parabola and yet not be one. It may even have all six of the properties above; and still it will not be a true parabola, unless all points on it are exactly equidistant from some fixed point and fixed line.

§ 207. **Applications.** The parabola is a frequently encountered and much-used curve.

A steel girder, or the cable of a suspension bridge, if loaded uniformly per horizontal foot, will hang in a parabola (the axis of which is vertical). The arches of a bridge, or high ceiling, are often made parabolic, — likewise the “*crown*” of a pavement.

The hollow upper surface of a rotating fluid is parabolic. (Fig. 43, p. 128.) So are the reflecting surfaces used in searchlights and telescopes.

The orbits of some comets, the paths of projectiles in a vacuum, and the graphs of many scientific formulas are parabolas.

§ 208. **Parabola with Axis Vertical.** If the axis of a parabola is turned straight upward, the focus being at  $(0, p)$  on

the  $Y$ -axis, and the directrix  $p$  units below the  $X$ -axis, the only change in the equation (15) will be that  $x$  and  $y$  will be interchanged. [Draw a rough figure to illustrate this.] The equation, then, will be

$$x^2 = 4 py. \quad (17)$$

**Ex. I.** A parabolic suspension cable is to have its ends 200 ft. apart and 40 ft. higher than the middle. Required, the equation of the curve, and the height 50 ft. from the center.

With the origin taken at the lowest point the equation is of the form (17). But we are to have  $y = 40$  when  $x = 100$ , at the end. Substituting gives  $4 p = 250$ .

$$\therefore x^2 = 250 y. \quad (\text{Check?})$$

At  $x = 50$ , this equation gives  $y = 10$ . The cable will be 10 ft. above its lowest point 50 ft. from the middle; and a vertical strand to reach from the cable to the bridge should be cut accordingly.

### EXERCISES

1. Draw by inspection:  $y^2 = 20 x$ ,  $y^2 = 12 x$ ,  $y^2 = 2 x$ . In each case, where are the focus and directrix?

2. The same as Ex. 1 for:  $x^2 = y$ ,  $x^2 = 10 y$ ,  $x^2 = .04 y$ .

3. Test without plotting which of the following points are on the parabola  $y^2 = 12 x$ : (3, -6), (4, 7), (27, 18), (16, -14), (1/3, -2), (75, 30), (0, 0), (-3, 6), (-12, -12).

4. For what value of  $p$  will the parabola  $y^2 = 4 px$  pass through (10, 20)? Find the point on that parabola at which  $y = 8$ .

5. Find the equation of a parabola whose axis is vertical, whose vertex is at the origin, and which passes through (10, 4).

6. The hollow upper surface of a rotating fluid is parabolic: 8 in. deep and 40 in. across. Find the equation of the curve, taking the lowest point as (0, 0). Find  $y$  at  $x = 10$ .

7. A ship's deck rises in a parabolic curve to a height of 9 ft. 3¼ in. in a horizontal distance of 256 ft. 3 in. Find the equation of the curve; and the height at  $x = 50$ .

8. A suspension cable is so loaded as to hang in a parabola. Its ends are 800 feet apart and 100 feet above the lowest point. Find its simplest equation; also its height at  $x = 80$  and  $x = 200$ .

9. A level foot-bridge of span 200 ft. is supported by a parabolic suspension cable from towers 30 ft. above the floor, the center of the

cable being 5 ft. above the floor. How long a wire is necessary to reach vertically from the cable to the floor 20 ft. from the center? 50 ft. from the center?

10. Write the equation of a parabola with focus (4, 0) and directrix  $x = -4$ .

11. Finish deriving the equation  $y^2 = 4px$  in § 205.

12. A circle moves and changes size so as to be always tangent to a fixed line and pass through a fixed point not on the line. Mark several positions of the center. Apparently what locus? Proof?

13. The great reflecting telescope at Mt. Wilson is a parabolic mirror 5 ft. across. The distance from vertex to focus is 25 ft. Find the equation of the parabola, with its axis vertically upward. How deep is the mirror at the center?

14. Prove that the area under the parabola  $y = x^2$  from  $x = 0$  to  $x = b$ , is precisely one third of the circumscribed rectangle having the same base.

§ 209. **Rotating a Curve 90°.** It is important to know how the equation of any curve will be modified when the curve is moved to some new position without changing its shape or size.

Let us first consider the effect of merely turning a curve 90° about the origin, counter-clockwise. (Fig. 100.) If  $(x_1, y_1)$  is a point on the original curve, and  $(x_2, y_2)$  the corresponding point on the new curve, then

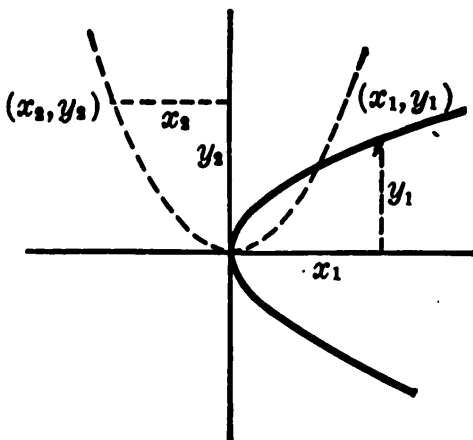

FIG. 100.

$$x_1 = y_2, \quad y_1 = -x_2. \tag{18}$$

That is, each  $x$  in the original equation will be replaced by  $y$  and each  $y$  by  $-x$ .

*E.g.*, if the parabola  $y^2 = 4px$  is rotated 90°, its equation will be

$$(-x)^2 = 4p(y), \quad \text{i.e.,} \quad x^2 = 4py. \quad [\text{Cf. (17).}]$$

If rotated another  $90^\circ$ , so that its axis extends to the *left*, along the negative  $X$ -axis, its equation changes to  $y^2 = -4px$ . And, if rotated still another  $90^\circ$ ,  $x^2 = -4py$ . (Verify this. Also see what effect a *fourth* rotation would have.)

Hence each of the equations

$$y^2 = \pm 4px, \quad x^2 = \pm 4py \quad (19)$$

represents some parabola. We need not memorize how the curve is turned for each of these equations; but in any given case simply make a substitution or two. Or notice which variable,  $x$  or  $y$ , may have both positive and negative values.

Ex. I. Locate the parabola  $x^2 = -12y$ .

Clearly  $x$  can be either positive or negative; but  $y$  cannot be positive. Hence no part of this parabola is above the  $X$ -axis; and the curve must extend along the negative  $Y$ -axis. (Draw the figure.)

Of course the focus and directrix are carried along with a parabola in its rotation. Hence the focus here is  $(0, -3)$  on the  $Y$ -axis, and the directrix is  $y = 3$ .

### EXERCISES

1. Draw by inspection  $x^2 = -40y$  and  $y^2 = -16x$ . Mark each focus and directrix, and test by measurement whether some of your points are equidistant.

2. The same as Ex. 1 for the curves  $3x^2 = -10y$  and  $x + 2y^2 = 0$ .

3. Write the equation of a parabola with focus  $(-7, 0)$  and directrix  $x = 7$ ; likewise of a parabola with focus  $(0, -1)$  and directrix  $y = 1$ .

4. Find the equation of a parabola through  $(-6, -9)$ , with vertex  $(0, 0)$  and axis vertically downward.

5. A roadway 40 ft. wide is 1 ft. lower at the sides than in the middle. If the curve of the "crown" is a parabola, find its equation. What is the drop in 10 ft. from the middle?

6. The curve of a ship's deck athwartship is a parabola which, in a horizontal distance of 27 ft. from the center, falls 13.5 inches. Find its equation. How much does the deck fall in the first 20 ft.? What is the slope 15 ft. from the center?

7. The steel arch of a bridge is a parabola with axis downward. The horizontal span is 400 ft., and the center is 120 ft. above the ends. Find the equation of the arch with the origin at the vertex. Plot the curve.

8. In Ex. 7, a level road-bed, 20 ft. above the vertex, is supported by vertical columns, from the arch, 40 ft. apart. Find the lengths of the columns at  $x = 40$  and  $x = 120$ .

[9.] A point  $(x, y)$  moves so that the sum of its distances from  $(-16, 0)$  and  $(16, 0)$  is always 40. Find the equation of its path, simplified. (Transpose one radical before squaring.) Locate several points by compasses and draw.

10. Prove this theorem: Any tangent to a parabola makes equal angles with the axis (produced) and with the radius from the focus to the point of tangency. [Hint: The slope of  $PT$  is  $y_1/TH$ , but by § 206 it is also  $2p/y_1$ . Equating, and remembering that  $y_1^2 = 4px_1$ , we may show that  $TH = 2x_1$  and hence that  $TF = FP$ . Carry out the details of the proof.]

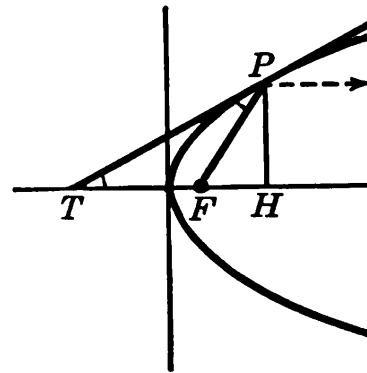

FIG. 100 a.

*Remark.* The reflection property of parabolic surfaces depends on this theorem. Rays of light entering parallel to the axis will be focussed at  $F$ . Conversely, rays emanating from a source at  $F$  will emerge parallel to  $TF$  as a non-scattering beam.

§ 210. **The Ellipse.** *Definition:* An ellipse is the locus of a point whose distances from two fixed points have a constant sum. The two fixed points  $F$  and  $F'$  are called the foci.

Any number of points on an ellipse can be found by describing arcs from  $F$  and  $F'$  with various radii,  $FP$  and  $F'P$ , whose sum is constant. (Fig. 101.)

Or the ellipse may be drawn by *continuous motion*. Take a string longer than the distance  $FF'$ , and fasten its ends at  $F$  and  $F'$ . Then, if a pencil point  $P$  keeps the string taut, it will move in such a way that  $FP + F'P$  is constant, — *i.e.*, along an ellipse. (A loop of string passed around two pins at  $F$  and  $F'$ , and drawn taut, accomplishes the same result more conveniently.)

Evidently an ellipse must be a smooth symmetrical oval, as in Fig. 101. But not every such oval is an ellipse. In a true ellipse, the sum of  $FP$  and  $F'P$  must be absolutely constant for all points. (Cf. Ex. II, § 203.)

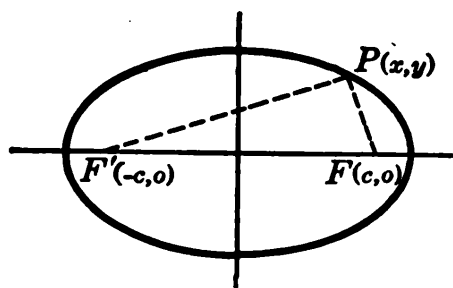

FIG. 101.

§ 211. **Type Equation.** Denote by  $2c$  the distance between the foci; and by  $2a$  the constant sum  $FP + F'P$ . (Fig. 101.) Clearly  $2a$  must be greater than  $2c$ .

Choose axes as in the figure, making the coördinates of the foci  $(c, 0)$  and  $(-c, 0)$ . Then by the distance formula:

$$FP = \sqrt{(x-c)^2 + y^2}, \quad F'P = \sqrt{(x+c)^2 + y^2}.$$

At every point of the ellipse, and at no others:

$$FP + F'P = 2a.$$

$$\sqrt{(x-c)^2 + y^2} + \sqrt{(x+c)^2 + y^2} = 2a.$$

Transposing one radical, squaring, and simplifying:

$$cx + a^2 = a\sqrt{(x+c)^2 + y^2}.$$

Squaring again and simplifying:

$$\frac{x^2}{a^2} + \frac{y^2}{a^2 - c^2} = 1.$$

Since  $a > c$ , as noted above,  $a^2 - c^2$  is positive and may be regarded as the square of some real number  $b$ . Substituting  $b^2$  for  $a^2 - c^2$ :

$$\frac{x^2}{a^2} + \frac{y^2}{b^2} = 1. \quad (20)$$

This is the type equation of the ellipse, when the  $X$  and  $Y$  axes are chosen as above.

**Ex. I.** What will the equation be if the ellipse is drawn with a string 10 in. long whose ends are 8 in. apart?

Here  $2a = 10$ ,  $2c = 8$ . Hence  $b^2 = a^2 - c^2 = 9$ , and the equation is

$$\frac{x^2}{25} + \frac{y^2}{9} = 1.$$



*Remark.* To draw this ellipse roughly by inspection of its equation, simply find where it crosses the  $X$  and  $Y$  axes:

$$y=0, \quad x=\pm 5; \qquad x=0, \quad y=\pm 3.$$

Then draw a smooth symmetrical oval through these four points.

§ 212. **Axes and Foci.** The constants  $a$  and  $b$  of equation (20) appear very plainly in the ellipse. For the curve crosses its axes of symmetry at the points

$$y=0, \quad x=\pm a; \qquad x=0, \quad y=\pm b.$$

Thus the diameters  $AA'$  and  $BB'$  are  $2a$  and  $2b$ .

Observe that the major axis  $2a$  equals the "constant sum" mentioned in the definition, — *i.e.*, equals the length of string required to draw the ellipse.

Observe also in Fig. 102 that  $FB$  and  $F'B$ , whose sum is  $2a$  by the definition, must each equal  $a$ . That is, *the distance from either end of the minor axis to either focus is equal to half the major axis*. By using this fact, we can construct the foci geometrically, when  $a$  and  $b$  are known. Knowing the foci, we can draw the ellipse with a string, if desirable.

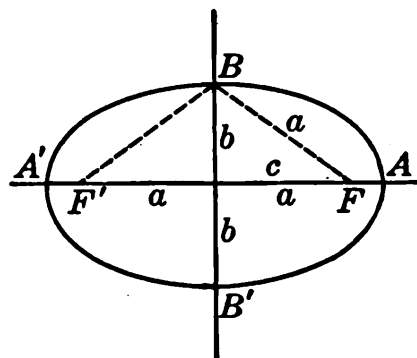

FIG. 102.

Moreover, if we get this triangular relation clearly in mind, we need not memorize the equation  $b^2 = a^2 - c^2$ , for the triangle will supply it.

How flat an ellipse will be is determined by the relative magnitude of the distance  $2c$  between the foci and the "constant sum"  $2a$ . The ratio  $c/a$  is called the *eccentricity*.

*Remark.* If the ellipse is rotated through  $90^\circ$ , so that the major axis is vertical and the foci are on the  $Y$ -axis instead of the  $X$ -axis, the equation (by § 209) will be simply

$$\frac{y^2}{a^2} + \frac{x^2}{b^2} = 1.$$

The only change is that  $y$  now has the larger denominator. But no rule is necessary as to this; for inspection of the equation at  $x=0$  and at  $y=0$  will show the lengths of the two axes.

**§ 213. Applications.** Many ellipses are encountered in nature: the orbits of the earth and other planets; the meridians on the earth's surface; any oblique section of a circular cylinder; the intersection of two equal circular cylinders or tunnels.

Ellipses are also much used in practical work: In making machine-gears, man-holes in ships' decks, the arches of many artistic bridges, and, in general, wherever a shapely oval is needed, as in a flower-bed, or an eye-glass, etc. The roofs of "whispering galleries" are elliptical in shape: faint sounds originating at one focus are reflected to the other, and can be heard there, though inaudible between.

#### EXERCISES

1. Draw by inspection the ellipses

$$(a) \quad \frac{x^2}{289} + \frac{y^2}{64} = 1,$$

$$(b) \quad \frac{x^2}{16} + \frac{y^2}{25} = 1,$$

$$(c) \quad 16x^2 + 25y^2 = 10000,$$

$$(d) \quad 9x^2 + 4y^2 = 144.$$

Find the foci of each.

2. To draw accurately the ellipses in Ex. 1, how long a string would be needed in each case, and how far apart should the ends be?

3. Draw by inspection, showing the centers and foci, if any:

$$(a) \quad \frac{x^2}{81} + \frac{y^2}{225} = 1,$$

$$(b) \quad x^2 = -24y,$$

$$(c) \quad 25x^2 + 4y^2 = 100,$$

$$(d) \quad 3x^2 - 17y = 0,$$

$$(e) \quad 4x^2 + 9y^2 = 36,$$

$$(f) \quad 2x^2 + 2y^2 = 25.$$

4. Write the equation of an ellipse with center at  $(0, 0)$  and axes along  $OX$  and  $OY$ , for which

(a) Longest diam. (horizontal) = 12 in., shortest diam. = 6 in.,

(b) Longest diam. (vertical) = 7 in., shortest diam. = 4 in.,

(c) Longest diam. = 10 in., foci are the points  $(-3, 0)$ ,  $(3, 0)$ ;

(d) Shortest diam. = 26 in., foci are the points  $(0, 5)$ ,  $(0, -5)$ .

5. An ellipse is drawn with a string 50 cm. long, whose ends are 30 cm. apart. Find its simplest equation.

6. Using pins 12 in. apart, and a loop of string whose total length is 32 in., what  $a$  and  $b$  will the resulting ellipse have? Verify by drawing.

7. The ellipse in which the earth travels around the sun has its longest diameter = 186 000 000 mi., and the distance between foci = 3 000 000 mi. Draw it to some convenient scale, using a string. Also write its equation.

8. (a) In the ellipse  $16x^2 + 25y^2 = 400$ , inscribe a rectangle having two sides in the lines  $x = 4$  and  $x = -4$ . Find its area. (b) Calculate the area of the largest rectangle which can be inscribed in this ellipse.

9. The arches of London Bridge are semi-ellipses, the central one having a span of 152 ft. and a height of 37.8 ft. Draw the arch to scale. Also find its equation.

10. A bridge has an elliptical arch, of span 80 ft. and height 16 ft. Find the equation and draw the curve. The level roadway is 5 ft. above the vertex. How far is it above the arch at  $x = 10$  and at  $x = 20$ ?

11. If every ordinate of a circle of radius 10 inches is reduced to half its value, show that the resulting curve is a true ellipse. (Hint: If  $(x, y)$  is on the new curve, then  $(x, 2y)$  is on the circle.)

12. A point  $(x, y)$  moves so that its distance from  $(-16, 0)$  is always  $\frac{4}{5}$  of its distance from the line  $x = -25$ . Derive the equation of the path. Draw the figure, and check for some special point.

§ 214. Further Properties. An ellipse has numerous interesting geometrical properties, two or three of which may be mentioned here.

(I) *Relation to the Major Circle.* Let a circle be circumscribed about an ellipse, its diameter being the major axis. Erect any ordinate  $y$  of the ellipse, and prolong it until it meets the circle. Call its length up to the circle  $Y$ . Then from the equations of the circle and ellipse,

$$x^2 + Y^2 = a^2, \quad \therefore Y = \pm \sqrt{a^2 - x^2}.$$

$$\frac{x^2}{a^2} + \frac{y^2}{b^2} = 1, \quad \therefore y = \pm \frac{b}{a} \sqrt{a^2 - x^2}.$$

Hence  $y = (b/a)Y$ . That is, any ordinate of the ellipse equals  $b/a$  times the corresponding ordinate of the major circle.

*E.g.*, in an ellipse having  $a=10$  and  $b=6$ , every ordinate is three fifths of the corresponding ordinate of the circumscribed circle.

(II) *Converse of (I)*. If in any curve every ordinate  $y$  equals some constant  $k$  times the corresponding ordinate  $Y$  of a circle, the curve must be an ellipse.

For, calling the radius of the circle  $a$ , we have

$$Y = \pm \sqrt{a^2 - x^2}, \quad y = \pm k \sqrt{a^2 - x^2}.$$

Simplifying the latter equation by squaring, transposing, etc., gives

$$\frac{x^2}{a^2} + \frac{y^2}{(ka)^2} = 1.$$

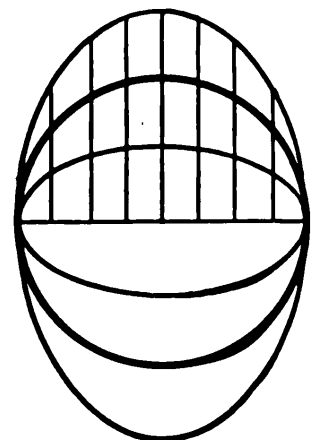

FIG. 103.

If  $k < 1$ , this represents an ellipse whose vertical axis  $(ka)$  is the shorter; and if  $k > 1$ , an ellipse whose vertical axis is the longer. (Fig. 103.)

*E.g.*, if we take a circle and reduce every ordinate to one half or two thirds of its original length, we get a true ellipse. Or if we lengthen every ordinate, say by 50%, we obtain an ellipse, with its major axis vertical.

(III) *Construction by Auxiliary Circles*. From the common center of two concentric circles, of radii  $a$  and  $b$  ( $a > b$ ), draw any radius meeting the outer circle at  $Q$  and the inner at  $R$ . Drop an ordinate  $QM$  from  $Q$ , and draw a horizontal line from  $R$  meeting  $QM$  at  $P$ . (Fig. 104.) Then the ordinates of  $P$  and  $Q$  have the same ratio as the radii. Hence this construction reduces each ordinate of the larger circle in the constant ratio  $b/a$ ; and by (II) the locus of  $P$  is an ellipse. We

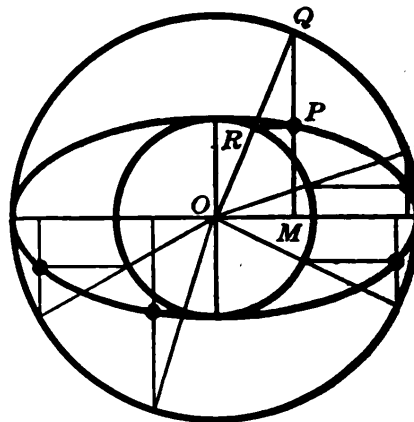

FIG. 104.

can construct accurately in this way as many points of an ellipse as we wish, with any desired semi-axes  $a, b$ .

(IV) *Projection of a Circle upon Another Plane.* Let a semi-circle of radius  $r$  be turned about its diameter until it makes some angle  $C$  with its former plane. (Fig. 62, p. 169.) Its projection on the former plane is some semi-oval, whose precise shape we wish to know.

Every ordinate ( $y$ ) of the semi-oval is the projection of some ordinate ( $Y$ ) of the semi-circle. By § 113,  $y = Y \cos C$ . Hence, by (II) above, the projection is a true ellipse, in which

$$a = r, \quad b = r \cos C.$$

Conversely, any ellipse, of semi-axes  $a$  and  $b$ , is the projection of some circle of radius  $a$ , inclined at an angle  $C$  whose cosine is  $b/a$ .

(V) *Area.* Let  $A$  be the area of any ellipse, and  $A'$  the area of the circle whose projection it is. Then, by § 113,

$$A = A' \cos C, = A' \left(\frac{b}{a}\right) = (\pi a^2) \left(\frac{b}{a}\right).$$

$$\therefore A = \pi ab. \tag{21}$$

Ex. I. The area of an ellipse of semi-axes 10 in. and 6 in. is  $60 \pi$  sq. in.

Ex. II. A damper in a circular stove pipe turned  $60^\circ$  from the position of complete obstruction cuts off an elliptic area in which  $a = r$ ,  $b = r \cos 60^\circ = .5 r$ , and hence  $A = .5 \pi r^2$ .

### EXERCISES

1. Every ordinate of a circle of diameter 50 in. was reduced in the ratio 4 : 5. What axes had the resulting ellipse? What area?

2. The circular damper of a pipe is turned  $35^\circ$  from the position of complete obstruction. What axes has the obstructed elliptical area?

3. The same as Ex. 12, p. 303, but using the point  $(-32, 0)$  and the line  $x = -50$ .

4. Find the volume of a cone whose height is 20 in. and whose base is an ellipse having longest and shortest diameters of 50 in. and 30 in.

5. The same as Ex. 4 for a height of 30 in. and diameters of 10 in. and 20 in.

6. (A) How long a loop of string should be used to lay out an elliptical flower bed 10 ft. long and 6 ft. wide; and how far apart should the fixed pins or stakes be? What area would the bed have? (B) The same for a bed 17 ft. by 8 ft.

7. In a photograph, the circular rim of a cup appeared as an ellipse. Explain this. Why do circular wheels, rings, lampshades, etc., appear elliptical when viewed obliquely? What shape, generally, is the shadow of a circular plate?

8. In a photograph of a new moon, the crescent is always bounded by a semi-circle and semi-ellipse. Why?

9. Supposing you had measured  $a$  and  $b$  for the semi-ellipse in Ex. 8 (say 5 cm. and 4 cm., respectively), how could you proceed to calculate the actual illuminated area of the moon shown in the crescent? (The moon's radius is 2163 mi.)

10. The Coliseum at Rome was elliptical in shape: 620 ft. long and 510 ft. wide. What ground area did it cover? Draw the ellipse to scale.

11. Carry out the construction of Fig. 104, using two circles of radii 5 cm. and 3 cm., approximately.

12. A straight line 80 cm. long moves with its ends on the  $X$  and  $Y$  axes. Find the path of a point  $P$  30 cm. from one end. (First mark several positions of  $P$  as the line turns, and draw the path. Then derive the equation.\*)

[13.] A point moves so that the *difference* of its distances from  $(-25, 0)$  and  $(25, 0)$  is always 40. Find the equation of the locus.

Construct enough points to determine the general character of the curve.

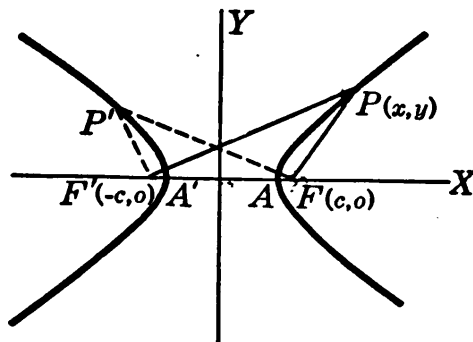

FIG. 105.

§ 215. **Hyperbola.** The locus of a point whose distances from two fixed points have a *constant difference* is called an *hyperbola*.

We can construct geometrically as many of its points as we wish, by describing arcs with centers at the fixed points  $F, F'$ , and with radii  $FP$  and  $F'P$  which differ by a fixed

\* Large ellipses are often drawn with a "trammel," using the principle of Ex. 12.

amount. (Fig. 105.) Two separate curves are obtained, according as we choose  $FP$  or  $F'P$  the larger. (The two curves together are called the hyperbola.) These curves can also be drawn by continuous motion.

An hyperbola is clearly symmetrical with respect to the line through the foci  $F, F'$ , and also with respect to the perpendicular bisector of  $FF'$ .  $A$  and  $A'$  are called the *vertices* and the distance  $AA'$  the *transverse axis*.

§ 216. **Type Equation.** Let the foci  $F, F'$  be denoted by  $(c, 0), (-c, 0)$ ; and the constant difference between  $FP$  and  $F'P$  by  $2a$ . (Clearly  $2a$  must be less than  $2c$ .)

Then at every point of the hyperbola, and at no others

$$\sqrt{(x+c)^2+y^2}-\sqrt{(x-c)^2+y^2}=2a, \text{ or } -2a.$$

Transposing, squaring, and finally putting  $c^2-a^2=b^2$ :

$$\frac{x^2}{a^2}-\frac{y^2}{b^2}=1. \tag{22}$$

(Since  $a < c$ ,  $c^2-a^2$  is positive and may properly be called  $b^2$ .)

Ex. I.  $x^2/9-y^2/16=1$ : an hyperbola with  $a=3, b=4, c=5$ .

That is,  $FF'$  is 10 units and the "constant difference"  $2a$  is 6.

Ex. II.  $x^2/16-y^2/9=1$ : an hyperbola with  $a=4, b=3, c=5$ .

That is,  $FF'$  is 10 units, and the constant difference  $2a$  is 8.

Observe that in an hyperbola,  $a$  may be either larger or smaller than  $b$ . But  $c$  is greater than either.

§ 217. **Nature of an Hyperbola.** Because of the symmetry of the curve, we need to discuss only that quarter in which  $x$  and  $y$  are both positive.

Solving (22) for  $y$  gives

$$y = \frac{b}{a} \sqrt{x^2 - a^2}. \tag{23}$$

When  $x < a$ ,  $y$  is imaginary; when  $x = a$ ,  $y = 0$ . Thereafter as  $x$  increases, so does  $y$ , and the curve continually rises.

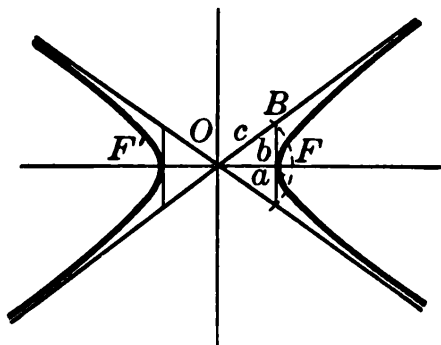

FIG. 106.

But  $y$  is always less than  $(b/a)\sqrt{x^2}$ . Hence the curve remains always below the line  $y = (b/a)x$ . This line is easily drawn; and will help in sketching the curve if we can tell how closely the latter will approach the line. (Fig. 106.)

The difference between the ordinate of the line,  $Y$ , and that of the hyperbola,  $y$ , is

$$Y - y = \frac{b}{a}(x - \sqrt{x^2 - a^2}). \quad (24)$$

When  $x$  becomes large, so will  $\sqrt{x^2 - a^2}$ . Will the *difference* become large or small? To find out, we multiply and divide by the *sum*  $x + \sqrt{x^2 - a^2}$ , getting

$$Y - y = \frac{b(x - \sqrt{x^2 - a^2})(x + \sqrt{x^2 - a^2})}{a(x + \sqrt{x^2 - a^2})} = \frac{b}{a} \cdot \frac{a^2}{x + \sqrt{x^2 - a^2}}.$$

It is now clear that  $Y - y$  approaches zero, as  $x$  becomes very great. Hence the hyperbola will come as close as we please to the line if we draw it far enough. The lower half of the curve must approach a similar descending line.

These two lines approached by the hyperbola, but not reached by it, are called *asymptotes*. Their equations are

$$y = \pm \frac{b}{a}x. \quad (25)$$

Hence they pass through  $(0, 0)$  and through the points where  $x = a$  and  $y = \pm b$ .

Ex. I. Draw by inspection the hyperbola  $\frac{x^2}{9} - \frac{y^2}{16} = 1$ .



When  $y=0$ ,  $x=\pm 3$ . (Vertices.) At each vertex we erect an ordinate  $b=4$ . Through  $(0, 0)$  and the ends of these ordinates we draw straight lines, the asymptotes. Starting at  $(\pm 3, 0)$  we draw the curve, approaching an asymptote as it recedes. (Draw the figure.)

*Remarks.* (I) Although the constant  $b$  of equation (22) does not show itself in the *curve*, it appears in the height of the asymptotes above the vertices.

(II) In Fig. 106,  $OB = \sqrt{a^2 + b^2}$ . That is, by § 216,  $OB$  is  $c$ , half the distance between the foci  $F$  and  $F'$ . Hence to locate  $F$  and  $F'$  geometrically, we need only describe a circle with center  $O$  and radius  $OB$ . Fix this picture in mind, and you need not remember the formula  $c^2 = a^2 + b^2$ , nor the equations  $y = \pm (b/a)x$ .

EXERCISES

1. What are  $a$ ,  $b$ , and  $c$  for the hyperbolas  $x^2/16 - y^2/9 = 1$ ,  $x^2/4 - y^2/9 = 1$ , and  $x^2/3 - y^2/5 = 1$ ?

2. Write the equation of an hyperbola whose foci are  $(\pm 10, 0)$ , and whose constant difference  $2a$  is 12; also of another with foci  $(\pm 6, 0)$  and  $2a = 10$ .

3. Draw by inspection, showing asymptotes and foci:

(a)  $\frac{x^2}{64} - \frac{y^2}{36} = 1,$

(b)  $\frac{x^2}{36} - \frac{y^2}{64} = 1,$

(c)  $\frac{x^2}{400} - \frac{y^2}{225} = 1,$

(d)  $\frac{x^2}{225} - \frac{y^2}{400} = 1.$

4. Draw by inspection, showing centers and foci, if any:

(a)  $x^2 + y^2 = 625,$

(b)  $9x^2 + 25y^2 = 3600,$

(c)  $x^2 - 4y = 0,$

(d)  $9x + y^2 = 0.$

5. A circle moves and changes size so as to remain always tangent to two fixed unequal circles. Mark several positions of the center and state what the locus is. Proof?

6. The same as Ex. 5 but using a fixed straight line and circle instead of two fixed circles.

7. A point moves in such a way that its distance from  $(-25, 0)$  is always  $\frac{1}{2}$  of its distance from the line  $x = -16$ . Find the equation and draw the path. Check some particular point.

8. The same as Ex. 7 for  $(-50, 0)$  and the line  $x = -32$ .

**§ 218. Hyperbola with Axis Vertical.** If the hyperbola  $x^2/a^2 - y^2/b^2 = 1$  is rotated  $90^\circ$ , its new equation, found by replacing  $x$  by  $y$  and  $y$  by  $-x$  (§ 209), will be

$$\frac{y^2}{a^2} - \frac{x^2}{b^2} = 1. \quad (26)$$

Thus the  $y^2$  term will be positive and the  $x^2$  term negative. Either  $x^2$  or  $y^2$  may have the larger denominator.

No rule is needed to tell whether an hyperbola has a horizontal or vertical position: simply try  $x=0$  and  $y=0$  in the equation.

Ex. I. 
$$\frac{y^2}{9} - \frac{x^2}{25} = 1.$$

If  $x=0$ ,  $y = \pm 3$ ; if  $y=0$ ,  $x = \text{imaginary}$ .

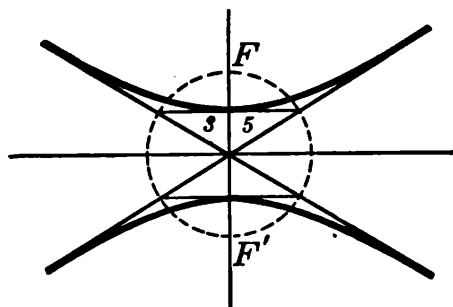

FIG. 107.

The curve meets the  $Y$ -axis 3 units above and below  $(0, 0)$ , but does not meet the  $X$ -axis at all. It is turned vertically.

The geometrical relation of the foci, asymptotes, etc., to the curve must be the same, no matter how the curve may be turned with respect to the  $X$

and  $Y$  axes. *The entire figure of auxiliary lines is rotated with the curve.* (Fig. 107.)

Hence to draw this hyperbola, we start at  $(0, 3)$  and  $(0, -3)$ , where the curve meets the  $Y$ -axis, lay off horizontal lines 5 units long, draw the asymptotes, and fill in the curve.

**§ 219. Sound Ranging.** In warfare, an invisible enemy gun can be located with the help of instruments called "microphones," which record to .01 sec. the time when the sound of the firing of the gun reaches various "listening posts" along our front.

To illustrate, suppose that a sound wave from a gun  $G$  reaches post  $A$  .08 sec. sooner than post  $B$ . Then, according to the velocity of sound,  $G$  is about 27 meters nearer  $A$  than  $B$ .

Now the locus of points 27 meters nearer  $A$  than  $B$  is one branch of an hyperbola with foci at  $A$  and  $B$ , and having  $2a = 27$ .  $G$  must lie somewhere along this hyperbola. Similarly, considering other posts  $C$ ,  $D$ ,  $E$ , etc.,  $G$  must lie somewhere along certain other hyperbolas, and hence at the common intersection of all.

The hyperbolas can be drawn; for in each case the known distance between posts (as  $AB$ , etc.) is  $2c$ ; and  $2a$  has been found by the microphones. If, as is usual, the gun is far away, the hyperbolas will practically coincide with their asymptotes in its vicinity; and *only the asymptotes need be drawn*. The value of  $b$ , used with  $a$  in drawing the asymptotes (§ 217), is easily found, since  $b^2 = c^2 - a^2$ .

The microphones in like manner locate the bursting shells from our own artillery and show whether we are shooting over or short, and whether to the right or left.

### EXERCISES

1. Draw these curves, showing the foci and asymptotes:

$$(a) \quad \frac{y^2}{64} - \frac{x^2}{35} = 1, \quad (b) \quad \frac{y^2}{9} - \frac{x^2}{16} = 1,$$

$$(c) \quad 4y^2 - 9x^2 - 36 = 0, \quad (d) \quad 9x^2 - 25y^2 + 900 = 0.$$

2. "Listening posts" are located at  $A$  (0, 2000),  $B$  (0, 1000),  $C$  (800, 400), and  $D$  (2000, -100). Microphones show a gun  $G$  to be located 506 m. nearer  $A$  than  $B$ , 280 m. nearer  $C$  than  $B$ , and 500 m. nearer  $D$  than  $C$ . Plot; and draw the required asymptotes to find  $G$ .

3. The same as Ex. 2 for posts located at  $A$  (0, 0),  $B$  (2000, 0),  $C$  (3600, 0), and  $D$  (6000, 1000), and with the gun  $G$  1414 m. farther from  $A$  than from  $B$ , 954 m. farther from  $B$  than from  $C$ , and 1944 m. farther from  $C$  than from  $D$ .

[4.] A point  $(x, y)$  moves so that the difference of its distances from (10, 10) and (-10, -10) is always 20. Find the equation of its path. Calculate a few points and plot.

[5.] Draw the ellipse  $16x^2 + 25y^2 = 400$ ; also the same curve moved 8 units to the right and 6 units upward, without rotation. What should the new equation be? [Hint: If  $(X, Y)$  is on the new curve,

then  $(X-8, Y-6)$  was on the old one, and these values must satisfy the old equation.] Compare the new equation with that of a circle whose center has been moved from  $(0, 0)$  to  $(8, 6)$ .

§ 220. **Rectangular Hyperbolas.** If an hyperbola of constant difference  $2a$  has its foci at  $(a, a)$  and  $(-a, -a)$ , on the line through  $(0, 0)$  inclined  $45^\circ$  to the axes, its equation is, by Ex. 4, p. 314,

$$xy = a^2/2.$$

By giving  $a$  different values, a set of such hyperbolas is obtained whose equations are all of this form, or

$$xy = k. \quad (27)$$

Moreover, for every value of the constant  $k$ , except  $k=0$ , this equation represents some hyperbola, — viz., one in which

$$a = \sqrt{2k}.$$

The asymptotes of all these hyperbolas are simply the  $X$  and  $Y$  axes. For, by (27), when  $x$  becomes very great,  $y \rightarrow 0$ ; and *vice versa*.

Because of the fact that the asymptotes are mutually perpendicular, these hyperbolas are called *rectangular*.

Such hyperbolas, with the axes for asymptotes, are often encountered in scientific work. They are also used in the business world in making certain calculations.

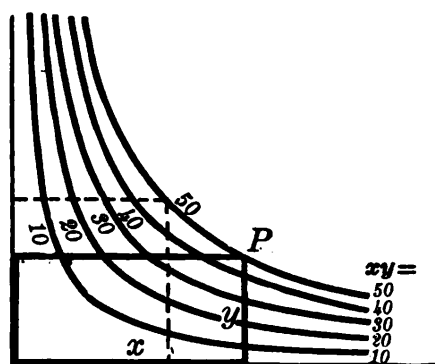

FIG. 108.

For instance, engravers use a chart like Fig. 108 to read off the price of a half-tone or zinc etching. Any desired rectangular plate is simply placed on the chart, with two of its edges along the  $X$  and  $Y$  axes. If its fourth corner  $P$  falls, say, anywhere along the curve  $xy=50$ , then its area is 50 sq. in. The price to quote for a plate of that area is marked on the hyperbola, and similar prices on the other curves, — which come at frequent intervals, — so that no calculation is necessary.

§ 221. **Parabolic and Hyperbolic Formulas.** As already noted, it is very common for one quantity to vary as a power of another:

$$y = kx^n. \tag{28}$$

Hence it is well to be familiar with the graphs of such formulas.

When  $n = -1$ , (28) becomes  $y = k/x$  or  $xy = k$ . The graph is then a *rectangular hyperbola*. For any other negative

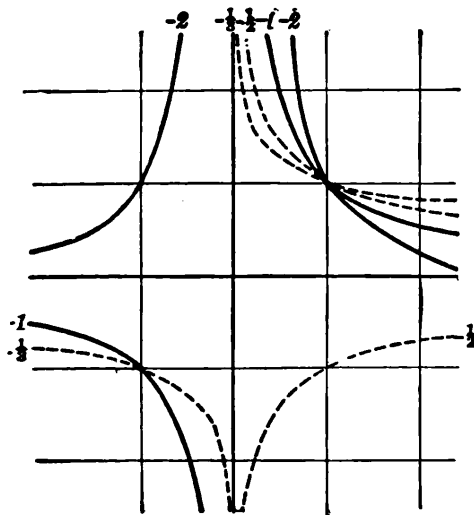

FIG. 109.

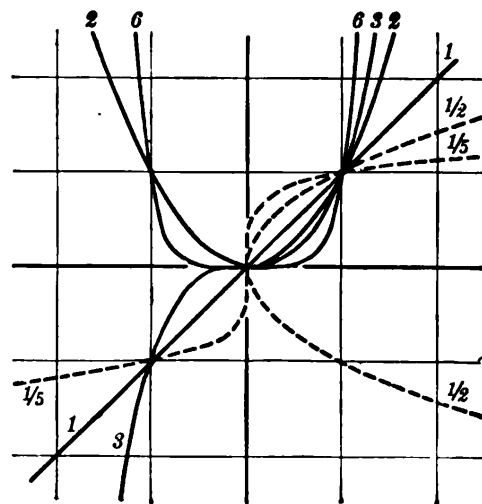

FIG. 110.

value of  $n$ , the graph will be somewhat similar, approaching the axes asymptotically. If  $n$  is odd,  $y$  will be negative when  $x$  is. (Fig. 109.)

When  $n = +2$ , the graph is the *parabola*  $y = kx^2$  with its axis *vertical*. In fact, whenever  $n > 1$ , the graph is very similar (for positive values of  $x$ ), rising slowly at first and then rapidly. (Fig. 110.)

When  $n = \frac{1}{2}$ , the graph is the *parabola*  $y^2 = (k^2)x$ , with its axis *horizontal*; and for other positive values of  $n$  less than 1, and  $x$  positive the graph is very similar.

For any positive value of  $n$ , (28) is called a *parabolic formula* and the graph a *parabolic curve*. Similarly for negative values of  $n$  the formula and curve are called *hyperbolic*. For several illustrations of each, see Ex. 3, p. 314; Ex. 7, p. 84; also pp. 102-103.

## EXERCISES

1. Verify the general shape of each curve in Fig. 109 by calculating three scattered points on each.
2. The same as Ex. 1 for the curves in Fig. 110.
3. Show the general shape of the graph for each of the following scientific laws. Here  $k$  and  $g$  denote constants.
  - (a) Falling bodies:  $s = \frac{1}{2} gt^2$ ,  $v = gt$ .
  - (b) Speed after falling  $h$  ft.:  $v = \sqrt{2gh}$ .
  - (c) Time of a pendulum:  $T = 2\pi\sqrt{l/g}$ .
  - (d) Boyle's Law for gases:  $pv = k$ .
  - (e) Adiabatic expansion:  $pv^{1.41} = k$ .
  - (f) Magnetic repulsion:  $F = k/d^2$ .
  - (g) Electric currents' intensity:  $i = k/R$ .
4. The point  $(x, y)$  moves so that the difference of its distances from  $(k, k)$  and  $(-k, -k)$  is always  $2k$ . Find its path. From the definition, what is the distance between vertices? Verify by the equation.
5. Draw the hyperbola  $xy = k$  for  $k = 20, 30, 40$ . If zinc etchings cost 20¢ per sq. in., label each of your curves with the cost of any plate which fits it as in Fig. 108.
6. Steel weighs 7.83 gm. per cc. State how you could make a chart for reading off the weights of rectangular steel plates 1 cm. thick.
7. Find the area under the curve  $xy = 50$  from  $x = 5$  to  $x = 20$ .

§ 222. **Translating a Curve.** Let us now see how the equation of a curve will be affected if we move the curve horizontally or vertically, without rotating it or changing its shape or size.

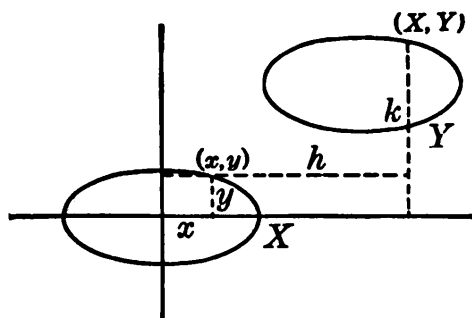

FIG. 111.

Let  $x, y$  be the coordinates of any point on the original curve; and  $X, Y$  be the coordinates of the same point after the curve has been moved, say  $h$  units to the right and  $k$  units upward. (Fig. 111.) Then

$$x = X - h, \quad y = Y - k. \quad (29)$$

That is, the old coördinates equal the new ones diminished by  $h$  and  $k$ . Hence the equation of the curve in its new position is obtainable by *replacing each  $x$  in the original equation by  $(x-h)$  and each  $y$  by  $(y-k)$* .

Similarly, moving a curve  $h$  units to the left and  $k$  units downward will replace  $x$  by  $x+h$ , and  $y$  by  $y+k$ . Such constants  $h$  and  $k$ , which have the effect of sliding the curve along bodily, we shall call "translaters" or "sliders."

Ex. I. If the circle  $x^2+y^2=100$  is moved 4 units to the right and 3 units upward, what will its new equation be?

$$\text{Answer: } (x-4)^2+(y-3)^2=100.$$

(This agrees with § 201 for a circle with center (4, 3) and radius 10.)

Ex. II. Recognize  $(y-2)^2=10(x-7)$ .

This is the parabola  $y^2=10x$ , but moved 7 units to the right and 2 units upward. To draw it, start from (7, 2) as vertex instead of (0, 0); and run the axis horizontally to the right, just as if you were drawing  $y^2=10x$ .

Ex. III. Recognize

$$9x^2+72x-25y^2-100y+269=0.$$

Completing the squares for both the  $x$  and  $y$  terms:

$$9(x^2+8x+16)-25(y^2+4y+4)=-269+144-100=-225.$$

$$\therefore \frac{(y+2)^2}{9}-\frac{(x+4)^2}{25}=1.$$

This is the same curve as  $y^2/9-x^2/25=1$  (Fig. 107, p. 310), but moved 4 units to the left and 2 units downward. Hence we merely draw the curve represented by the latter equation, but starting from  $(-4, -2)$  as the center instead of (0, 0).

*Remark.* Observe that in translating a curve we replace each  $x$  by  $x\pm h$  and  $y$  by  $y\pm k$ ; never by  $y^2-k$  nor  $ax+h$ , nor any other expres-

sion. Hence to recognize  $y^2 + 12x - 7 = 0$  we must write it as  $y^2 = -12(x - \frac{7}{12})$ , rather than  $y^2 - 7 = 12x$  or some other form.

§ 223. **Path of a Projectile.** By § 191, if we ignore air resistance and take the firing point as  $(0, 0)$ , the equations of motion for a projectile fired in any way have the form

$$x = ct, \quad y = kt - 16t^2. \quad (30)$$

We can now determine the precise geometrical character of the path, — not by plotting, which merely shows the general shape of the curve, but by considering the relation between  $x$  and  $y$  at all times.

**EXAMPLE.** Find the path if  $x = 80t$  and  $y = 60t - 16t^2$ .

Here  $t = x/80$ , which gives in the  $y$ -equation:

$$y = 60\left(\frac{x}{80}\right) - 16\left(\frac{x}{80}\right)^2.$$

Simplifying, and completing the square gives:

$$x^2 - 300x + 150^2 = -400y + 150^2,$$

$$\text{i.e.,} \quad (x - 150)^2 = -400(y - 56\frac{1}{4}).$$

This is the parabola  $x^2 = -400y$  (with axis downward) but moved 150 ft. to the right and  $56\frac{1}{4}$  ft. upward. Thus the highest point is  $(150, 56\frac{1}{4})$ ; and the focus is 100 ft. directly below this, since  $4p = 400$ .

§ 224. **Conics.** It can be proved that the parabola, ellipse, and hyperbola, though defined differently in what precedes, are all in reality special cases of a single kind of curve called a *conic*, which is defined thus:

*A conic is the locus of a point whose distances from a fixed point and a fixed line have a constant ratio.*

Ex. 12 below and Ex. 12, p. 303, Ex. 7, p. 309, illustrate this. (What must the "constant ratio" be for a parabola?)



## EXERCISES

1. Recognize the "translaters" and draw the curves:

- (a)  $\frac{(x-3)^2}{25} + \frac{(y+2)^2}{16} = 1,$  (b)  $(y-1)^2 = 12(x+5),$   
 (c)  $x^2 + y^2 - 8x + 6y + 21 = 0,$  (d)  $x^2 + 8x = 10y + 14,$   
 (e)  $16x^2 - 32x + 9y^2 + 18y = 264,$  (f)  $x^2 + 4y^2 - 24y + 11 = 0.$

2. Draw by inspection, showing the asymptotes and the foci:

- (a)  $\frac{(x-8)^2}{64} - \frac{(y+6)^2}{36} = 1,$  (b)  $\frac{y^2}{9} - \frac{(x+10)^2}{16} = 1,$   
 (c)  $16x^2 + 32x - 9y^2 + 108y = 164,$  (d)  $9x^2 - 90x - 16y^2 - 320y = 799.$

3. An ellipse has its center at (4, 2), and is tangent to the  $X$  and  $Y$  axes. Write its equation by inspection. What are the foci?

✓ 4. An ellipse has the foci (4, 1) and (4, 7) and is tangent to the  $Y$ -axis. What is its equation?

5. A parabola has the point (8, -2) as focus and the line  $y = 4$  as directrix. Write its equation by inspection.

6. A point  $(x, y)$  moves so that the sum of its distances from (3, 2) and (9, 2) is always 10. Derive the equation of its path and check by your knowledge of the ellipse.

7. A point  $(x, y)$  moves so that its distance from (6, 0) is twice its distance from (0, 0). Find the equation of the path. What curve?

8. A projectile moved along the curve  $y = 4x/3 - x^2/22500$ . Locate the highest point by differentiation. Check by completing the square and recognizing the sliders.

9. A bullet traveled thus:  $x = 600t, y = 800t - 16t^2$ . Show that the path was a parabola; and draw it by inspection.

10. A projectile was fired with an initial speed of 2080 ft./sec. at an elevation angle whose sine is  $\frac{5}{13}$ . Find its equations of motion, and the equation of the path. Locate the vertex in two ways. Also find the focus and directrix.

11. Draw by inspection:  $(x + 100\,000)y = 15\,000\,000$ . [This formula and curve are used by a certain telephone company in testing the insulation of lines.]

12. A point moves so that its distance from (10, 0) equals a constant  $e$  times its distance from the  $Y$ -axis. Derive the equation of the path. What is the nature of the curve if  $e = 1$ ? If  $e = \frac{3}{5}$ ? If  $e = \frac{5}{3}$ ?

§ 225. **Plotting the Locus of Any Equation.** Certain curves can be drawn by recognizing their equations. Many others can be plotted by points.

Along any given curve  $y$  varies with  $x$  in some definite way. If we can solve the equation of the curve for  $y$  in terms of  $x$ , we have merely to plot the resulting function, — just as we did frequently in Chapters I–III.

The amount of calculation required for such plotting can often be greatly reduced by making a preliminary inspection of the equation, and thus learning certain facts in advance.

ILLUSTRATION. Plot the locus of  $xy^2 - 4y^2 + x^3 + 4x^2 = 0$ .

Here 
$$y = \pm x\sqrt{\frac{4+x}{4-x}}$$

(I) *Extent of the curve.* For any value of  $x$  which makes  $4+x$  or  $4-x$  negative,  $y$  is imaginary — *i.e.*, if  $x$  is below  $-4$  or above  $+4$ . Hence the curve exists only between  $x = -4$  and  $x = +4$ .

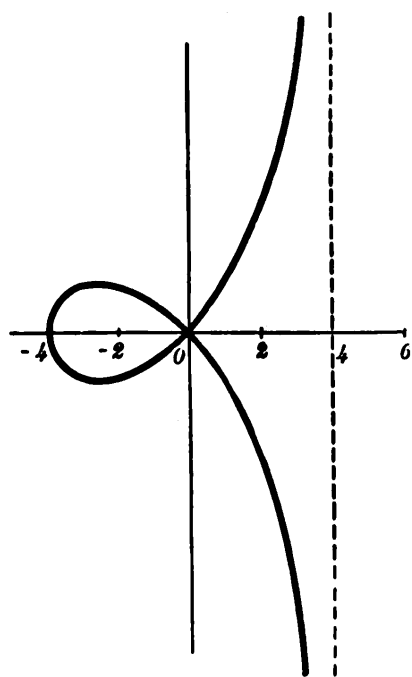

FIG. 112.

(II) *Symmetry.* Wherever real,  $y$  has two numerically equal but opposite values ( $\pm$ ). Thus the curve is symmetrical with respect to the  $X$ -axis. This is not so for the  $Y$ -axis.

(III) *Intersections with the axes.* When  $x = 0$ ,  $y = 0$ . But when  $y = 0$ ,  $x$  may be 0 or  $-4$ . For one of the factors  $x^2$  and  $(4+x)$  must be zero, and either may be. The curve passes through the origin, and also meets the  $X$ -axis four units to the left.

(IV) *Vertical asymptote.* At  $x = 4$  the equation takes the form  $y^2 = 16(8/0)$ , — which is entirely meaningless. (§ 29.)

Trying a value near 4, say  $x = 3.999$ , makes the denominator very small and hence  $y$  very large. If we let  $x \rightarrow 4$ , the curve must rise indefinitely high, approaching the line  $x = 4$  asymptotically.

(V) *Table.* Substituting values for  $x$  between  $-4$  and  $4$ , we draw the curve. (Fig. 112.)

*Remark.* Even when the equation of a curve is too complicated to solve for  $y$  in terms of  $x$ , or vice versa, we may still be able to find its intersections with numerous straight lines, suitably chosen, and by plotting those intersections obtain enough points to draw the curve. (See Ex. 5 below.)

### EXERCISES

1. Draw the following curves roughly :

$$(a) \quad y = (x-10)(x-7)(x-3)(x-1),$$

$$(b) \quad y^2 = (x-10)(x-7)(x-3)(x-1),$$

$$(c) \quad y^2 = (x-8)(x-5)(x-2)^2(x+3).$$

[First determine their intersections with the  $X$ -axis, and see what happens between each pair of such intersections.]

2. Plot  $y = x - 3$  and  $y = 1/(x - 3)$ , using the same axes. Could you have anticipated the character of the latter curve by careful inspection of the former?

3. Plot 
$$y^2 = \frac{x^3}{4-x}.$$

4. Plot 
$$y^2 = x^3 \frac{x+4}{x-4}.$$

What isolated point belongs to the complete locus of the equation?

5. Find where the curve  $x^3 + y^3 = 6xy$  cuts the lines  $y = x$ ,  $2x$ ,  $4x$ ,  $\frac{1}{2}x$ ,  $\frac{1}{4}x$ ,  $0$ ,  $-\frac{1}{2}x$ , etc. Plot these intersections and draw the curve.

[6.] Test by slopes whether  $(35, 39)$ ,  $(60, 60)$ , and  $(-20, -40)$  are on the straight line through  $(20, 10)$  whose slope is  $\frac{3}{4}$ . Can you express by an equation the fact that a point  $(x, y)$  is on this line?

[7.] Draw  $2x - 3y = 11$  and  $2x + y = 7$  and find the intersection. How could you find this without plotting?

§ 226. **Point-slope Equation of a Line.** Various geometrical properties of triangles relate to the intersections of

certain straight lines. In studying such properties algebraically, the first step is to be able to write the equation of any specified line. This is easy *if we know the slope  $l$  and some point  $(x_1, y_1)$  through which the line passes.*

If  $(x, y)$  is any point whatever along the line, then

$$\frac{y-y_1}{x-x_1} = l. \quad (31)$$

For by § 194 this fraction is the slope of the line joining  $(x, y)$  and  $(x_1, y_1)$  which is the line under consideration. Moreover, (31) is not true if  $(x, y)$  is any point off this line. Hence (31) is the equation of the line. Or, more simply,

$$y - y_1 = l(x - x_1). \quad (32)$$

*E.g.*, the line through  $(4, 5)$  with slope 2 is

$$y - 5 = 2(x - 4), \text{ i.e., } 2x - y = 3.$$

Note the distinction between  $(x, y)$  and  $(x_1, y_1)$ ; also that (32) cannot be applied to a vertical line, as there is then no such thing as a "slope." Along such a line, however, the value of  $x$  must remain constant, and hence the equation can be written at sight, in the form

$$x = \text{some constant.}$$

Ex. I. Find the equation of the perpendicular bisector of the line joining  $(5, 6)$  and  $(11, 14)$ .

$$\text{Slope of given line: } l_1 = \frac{14-6}{11-5} = \frac{4}{3}.$$

$$\text{Slope of required line: } l_2 = -\frac{3}{4}. \quad (\S 197)$$

The mid-point through which the required line passes is

$$x_1 = \frac{1}{2}(11+5) = 8, \quad y_1 = \frac{1}{2}(14+6) = 10.$$

Hence the equation of the required line through  $(8, 10)$  with slope  $-\frac{3}{4}$  is

$$y - 10 = -\frac{3}{4}(x - 8), \quad \text{or } 3x + 4y = 64.$$

## EXERCISES

- Write the equations of the following straight lines :
  - Passing through  $(8, 7)$  with the slope 3 ;
  - Perpendicular to the line in  $(a)$  from  $(6, 10)$  ;
  - Passing through  $(5, -1)$  parallel to the line in  $(a)$  ;
  - Passing through  $(6, 9)$  and  $(12, 10)$  ;
  - Through  $(6, -5)$  and bisecting the line from  $(4, -1)$  to  $(12, 15)$  ;
  - Perpendicular to and bisecting the line from  $(-7, 6)$  to  $(1, 14)$  ;
  - Through  $(0, 0)$  perpendicular to the line  $2x - 5y = 12$  ;
  - Through the mid-point of  $(8, 1)$  and  $(-18, 9)$  parallel to  $3x - 2y = 7$ .
- The vertices of a triangle are  $(7, -2)$ ,  $(13, 10)$ , and  $(-1, 16)$ . Find the equations of the sides. Does any side pass through  $(0, 0)$  ?
- Find the equations of the medians in Ex. 2. Is any one of them perpendicular to the opposite side ?
- A point moves so as to be equidistant from  $(9, -4)$  and  $(17, 8)$ . Show analytically that its path is the perpendicular bisector of the line joining those points.
- The same as Ex. 4 for the points  $(11, 4)$  and  $(-1, 12)$ .
- At what point on the parabola  $y^2 = 16x$  is the slope equal to 4 ? Write the equation of the tangent at that point.

§ 227. **Intersections of Loci.** If any point is common to two lines or curves, its coördinates must satisfy both equations at once. Thus the problem of finding the intersection of two curves is equivalent to the algebraic problem of solving a pair of simultaneous equations. This is easy in the case of straight lines, whose equations are always of the first degree.

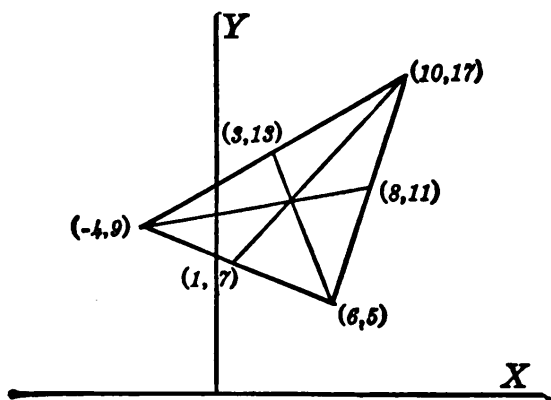

FIG. 113.

To see whether *three* lines are *concurrent* (i.e., pass through a common point), we solve for the intersection of two, and, by substituting in

the third equation, test whether this intersection lies on the third line.

Ex. I. Prove analytically that the medians of the triangle whose vertices are  $(-4, 9)$ ,  $(6, 5)$ , and  $(10, 17)$  are concurrent.

On each median we know a point, — viz., a vertex, — and we can find the slope after getting the opposite mid-point.

Vertices:	$(-4, 9)$	$(6, 5)$	$(10, 17)$
Opposite mid-pts.:	$(8, 11)$	$(3, 13)$	$(1, 7)$
Medians' slopes:	$\frac{1}{6}$	$-\frac{2}{3}$	$\frac{10}{9}$
Equations:	$\frac{y-9}{x+4} = \frac{1}{6}$ ,	$\frac{y-5}{x-6} = -\frac{2}{3}$ ,	$\frac{y-17}{x-10} = \frac{10}{9}$ .
Simplified:	$x-6y = -58$ ,	$8x+3y = 63$ ,	$10x-9y = -53$ .

To find the intersection of the first two medians, we solve the first two equations. Eliminating  $y$  gives  $x=4$ ; whence  $y=10\frac{1}{3}$ . Testing  $(4, 10\frac{1}{3})$  in the third equation shows that this point lies on the third median also. (*Q.E.D.*)

### EXERCISES

1. Find the intersection of the lines  $2x-3y=7$  and  $x+4y=15$ . Plot the lines and check your result.

2. The same as Ex. 1 for the lines  $2x+y=9$  and  $3x-2y=12$ .

3. Find the intersection of two medians of the triangle whose vertices are  $(8, 7)$ ,  $(4, -1)$ , and  $(2, 11)$ . Test whether the third median passes through the same point.

4. The vertices of a triangle are  $(-3, 2)$ ,  $(3, -4)$ , and  $(7, -2)$ . Find the equations of the perpendicular bisectors of the sides, and show that these bisectors are concurrent.

5. In Ex. 4 prove that the three altitudes are concurrent.

6. Find the equation of the circle circumscribed about the triangle whose vertices are  $(10, 5)$ ,  $(-4, -9)$ , and  $(10, -7)$ . (Hint: On what lines must the center lie?)

7. Find the equation of the circle through  $(0, 0)$ ,  $(8, 6)$ , and  $(-2, 10)$ .

8. Show that the medians of the triangle whose vertices are  $(7, 5)$ ,  $(3, -3)$ , and  $(-13, 1)$  are concurrent.

9. The vertices of a trapezoid are  $(-20, 0)$ ,  $(20, 0)$ ,  $(-13, 6)$ , and  $(19, 6)$ . Show that the non-parallel sides and the line joining the mid-points of the parallel sides all pass through a common point.

10. The same as Ex. 9 for the vertices  $(-15, 0)$ ,  $(15, 0)$ ,  $(13, 2)$ , and  $(-11, 2)$ .

11. Find the equation of a straight line passing through the intersection of  $4x - 3y + 5 = 0$ , and  $3x + 2y - 12 = 0$ , and also through the point  $(2, -1)$ .

12. If given the equations of the three sides of a triangle, how would you proceed to find the equations (a) of the medians? (b) Of the altitudes? (c) Of the circumscribed circle?

§ 228. **Summary of Chapter VIII.** Coördinates are useful in describing the location of a fixed point, or in following a moving point. The speed and direction of motion at any time can be found from  $v_x$  and  $v_y$ , which are merely the rates of change of  $x$  and  $y$ . The distance traveled during any interval can be found by integration. From the physical law of acceleration, equations of motion can be found for projectiles by repeated integrations. Also the precise geometrical nature of the path can be found. Thus in the study of motion, coördinates are almost indispensable.

Coördinates are also helpful in studying geometry. The test as to whether a point lies on a given curve is to see whether its coördinates satisfy a certain equation. This connection between curves and equations permits the study of geometrical properties of curves by means of their equations. (Cf. Ex. 10, p. 299.) Various theorems of Elementary Geometry relating to loci and intersections of lines are also easily proved analytically.

Perhaps this glimpse of Analytic Geometry, even if brief, will suggest the possibilities of the method. In more advanced courses a vast number of properties of the foregoing curves, and others, are worked out. One interesting fact is that the ellipse, parabola, and hyperbola can all be obtained by cutting a right circular cone by a plane.\*

\* The geometrical properties of these conic sections are of especial interest historically since by utilizing them modern Astronomy has explained the motions of the heavenly bodies and has freed mankind from the abject terror formerly produced by every unusual celestial phenomenon such as the apparition of a comet.

*Remark.* The work of this chapter is closely connected with our central problem of studying functions. For along any curve  $y$  varies with  $x$  in some definite way and is therefore a function of  $x$ .

There is, however, an important new element in the recent work. The equation of a curve is generally in the form of a *relation between the two variables*  $x$  and  $y$ , rather than a formula giving  $y$  explicitly in terms of  $x$ , as  $y=f(x)$ . The equation implies that  $y$  is a function of  $x$ , but it defines  $y$  as such only *implicitly*. Thus we may be said to be studying "implicit functions" now rather than "explicit functions."

We shall next see that the connection between equations and curves is sometimes of value in solving equations.

### EXERCISES

1. Draw by inspection: (a)  $4x - 3y = 12$ ; (b)  $x^2 + y^2 = 16$ ; (c)  $(x-9)^2 + (y+4)^2 = 25$ ; (d)  $y^2 = 12x$ ; (e)  $x^2 = 20y$ .
2. A point moves so that its distance from  $(6, 0)$  is always twice its distance from  $(0, 0)$ . Find the equation of the path and draw it.
3. Write by inspection the equation of a parabola whose focus is  $(0, 8)$  and whose directrix is 8 units below the  $X$ -axis.
4. The same as Ex. 3 if the focus is  $(3, 9)$  and the directrix is the line  $x = -5$ .
5. To draw an ellipse whose longest and shortest diameters are 20 in. and 12 in., how long a string would you use and how far apart would you fix the ends? How long a loop could be used?
6. If the foci of an ellipse are  $(-9, 4)$  and  $(-3, 4)$  and one vertex is  $(-6, 8)$ , what is the equation?
7. Derive the equation of the locus of a point  $(x, y)$  whose distance from the  $Y$ -axis constantly equals its distance from  $(16, 0)$ . Draw the curve roughly by inspection.
8. The same as Ex. 7, if the distance from  $(16, 0)$  is always  $\frac{5}{3}$  times the distance from the  $Y$ -axis.
9. A point moves so that its distance from  $(-34, 0)$  is always 30 units greater or less than its distance from  $(16, 0)$ . Find its path.
10. An ellipse has foci  $(5, 18)$  and  $(5, -6)$ , and is tangent to the  $Y$ -axis. Write its equation by inspection.
11. Find the center and foci, and draw each of the following curves:  $16x^2 - 640x + 25y^2 = 1600$ ;  $9x^2 - 18x - 25y^2 + 100y = 116$ .
12. Recognize and draw the curve  $y^2 - 12y + 12x = 0$ . What are the vertex and focus?



13. An hyperbola has the foci (3, 4) and (13, 4), and one vertex is (12, 4). Draw it roughly. Also write its equation by inspection.

14. A projectile was fired with an initial speed of 2000 ft./sec. at an inclination whose tangent equals  $\frac{3}{4}$ . Find the equations of motion and the equation of the path. Draw roughly. What focus?

15. Hell Gate Bridge, New York City, has a parabolic arch with a span of 977.5 ft. and a height of 220 ft. Draw the curve to scale.

**TABLE I**

<i>H</i>	<i>B</i>
0	-9000
5	-4500
10	+6000
25	13600
100	17200
150	18300
100	17250
25	14600
10	12500
5	11000
0	9000
- 5	4500
-10	-6000

etc., symmetrically.

16. As a magnetized piece of steel was carried around the "magnetic cycle," the magnetizing force *H* and the induction *B* ran through the values shown in Table I. Plot the curve. ("Hysteresis loop.") Compare its area with that of the rectangle with vertical and horizontal sides, which just contains the loop.

**TABLE II**

<i>x</i>	<i>y</i>
3° 22'	49° 34'.9
20'	33'.5
10'	26'.5
3° 0'	19'.4
2° 50'	12'.2
40'	4'.9
30'	48° 57'.5
20'	50'.0

17. When the "supergun" bombarded Paris from St. Gobain, its projectiles traveled a path along which the latitude *y* varied with the longitude *x* as in Table II. Plot this course, using 1 in. for 10' (longitude), and 1 in. for 6.5' (latitude), — the correct ratio for that vicinity. In what direction did the course run?

18. A point *P* moves in such a way that the tangent to its path is always perpendicular to a line joining *P* to a moving point on the *Y*-axis 10 units higher than *P*. Find the equation of the path. Draw by inspection.

19. If a point *P* (*x*, *y*) moves on the curve  $y^2 = 16x$ , and if *Q* (*X*, *Y*) is the mid-point of the chord joining *P* to the origin, find the equation of the curve in which *Q* moves. Draw the two curves roughly.

20. If a beam is embedded at one end in a wall, and carries a load at the free end, its slope will vary as the distance (*x* ft.) from the wall. What sort of a curve will it form?

21. The force (*F* lb.) driving an object varied thus with the distance (*x* in.) from a certain point:  $F = 5 + 20/x$ . What sort of graph? Find the work done from  $x = 2$  to  $x = 12$ .

22. The air resistance to an airplane (*P* lb./sq. in.) varied as the square of the speed (*V* mi./hr.), *P* being 180 when  $V = 60$ . Write the formula. What sort of graph? About what change in *P* between  $V = 49.9$  and  $V = 50.1$ ?

## CHAPTER IX

### SOLUTION OF EQUATIONS

§ 229. **Summary of Earlier Methods.** The methods of solving an algebraic equation which should already be familiar are as follows: \*

(1) Completing the square for any equation in quadratic form. (2) Factoring by inspection in simple cases, and equating each factor to zero. (3) Making trial substitutions synthetically to detect any integral roots. (4) Approximating any other real roots graphically.

We now proceed to refine some of these methods and obtain others.

#### (A) EXACT METHODS

§ 230. **Formula for the Roots of a Quadratic.** The most general equation of the second degree involving a single unknown has the form

$$ax^2 + bx + c = 0. \quad (1)$$

By completing the square the roots of this are found to be

$$x = \frac{-b \pm \sqrt{b^2 - 4ac}}{2a}. \quad (2)$$

This result should be carefully memorized. It can be used as a formula to write at sight the roots of any quadratic equation.

Ex. I. Find the roots of  $5x^2 + 11x + 3 = 0$ .

Here  $a = 5$ ,  $b = 11$ ,  $c = 3$ ;

$$\therefore x = \frac{-11 \pm \sqrt{61}}{10}.$$

\* See §§ 19, 21, 23 63.

Ex. II. Solve  $x^6 - 19x^3 - 216 = 0$ .

This is really a quadratic in terms of  $x^3$ . (We could let  $x^3 = z$ , say.)

$$\therefore x^3 = \frac{19 \pm \sqrt{19^2 - 4(-216)}}{2} = 27, -8.$$

There are six values for  $x$ . For, when  $x^3 - 27 = 0$ , factoring gives

$$(x-3)(x^2+3x+9) = 0.$$

Hence one of these factors must be zero:  $x-3=0$ , or  $x^2+3x+9=0$ .

$$\therefore x=3, \text{ or } x = \frac{-3 \pm \sqrt{-27}}{2}.$$

Similarly  $x^3 = -8$  gives  $x = -2$ , and two imaginary values.

**§ 231. Plotting a Rotated Conic.** In Analytic Geometry it is proved that every equation of the second degree in  $x$  and  $y$  represents some conic, — *i.e.*, ellipse, parabola, hyperbola, or pair of straight lines, — unless the locus is imaginary. If the equation contains no product term  $xy$ , it can be reduced to a type form with “translaters.” But if there is a term  $xy$  with other terms, we must rely mainly on plotting by points.

Ex. I. Plot the locus of

$$3x^2 + 9xy + 2y^2 = 13.$$

First we solve for  $y$  (say) in terms of  $x$ , noting that

$$a=2, \quad b=9x, \quad c=3x^2-13.$$

$$\therefore y = \frac{-9x \pm \sqrt{57x^2 + 104}}{4}.$$

We may now calculate points by substituting values for  $x$ .

The curve is clearly real, no matter how large  $x$  becomes, either positively or negatively. Hence, as it is some conic, it must be an hyperbola. Its axis is tilted about  $42^\circ$ .

### EXERCISES

1. Solve  $ax^2 + bx + c = 0$  by completing the square. [Cf. (2) above.] Can the two values of  $x$  ever be equal? If so, how? What part of the results determines whether the roots will be real or imaginary?

2. Using formula (2) write by inspection the roots of:

(a)  $7x^2 + 13x + 12 = 0$ , (b)  $8x^2 - 13x + 5 = 0$ ,  
 (c)  $11x^2 - 6x + 5 = 0$ , (d)  $4.8x^2 + .75x - .0125 = 0$ .

3. Solve each of these equations for  $y$ :

(a)  $y^4 - 10y^2 + 9 = 0$ , (b)  $y^6 - 26y^3 - 27 = 0$ .

4. If a wooden column ( $x$  in. square) is to carry a certain load, the smallest safe value of  $x$  is a root of  $x^4 - 125x^2 - 10368 = 0$ . Find that root.

5. The deflection of a loaded beam  $x$  ft. from one end is, under certain conditions,  $y = k(3x^5 - 4000x^3 + 1120000x)$ . At what value of  $x$  is  $y$  a maximum?

6. The same as Ex. 5 if  $y = k(3x^5 - 10l^2x^3 + 7lx)$  where  $l$  is the length of the beam.

7. Plot each of the following equations by calculating a table of points. Apparently what sort of curve is each locus?

(a)  $2x^2 - 2xy + y^2 = 2$ , (b)  $x^2 + y^2 - 2xy - 8x - 8y + 16 = 0$ ,  
 (c)  $x^2 + 5xy + 4y^2 = 9$ , (d)  $6x^2 - xy - 2y^2 + 7x + 7y - 5 = 0$ .

§ 232. The Discriminant,  $b^2 - 4ac$ . The nature of the roots of the equation  $ax^2 + bx + c = 0$  is determined by the quantity  $b^2 - 4ac$  which appears under the radical in (2).

The roots are *imaginary* if  $b^2 - 4ac$  is negative. Otherwise they are *real*.

The roots are *rational* if  $b^2 - 4ac$  is a perfect square. [They are then free from radicals.] Otherwise they are *irrational*.

The roots are *equal* if  $b^2 - 4ac$  is zero. [For  $(-b+0)/2a$  is the same as  $(-b-0)/2a$ .] Otherwise they are *unequal*.

*E.g.*, in the equation  $121x^2 - 176x + 64 = 0$  we have

$$b^2 - 4ac = (176)^2 - 4(121)(64) = 0.$$

Hence the roots are *real*, *rational*, and *equal*.

These criteria are often useful in determining quickly whether two given lines or curves intersect. *E.g.*, to find whether the line  $y = 2x + 12$  meets the circle  $x^2 + y^2 = 25$ ,

we need only see whether the two equations have a real simultaneous solution. Eliminating  $y$  gives

$$\begin{aligned} & x^2 + (2x + 12)^2 = 25, \\ \text{i.e.,} \quad & 5x^2 + 48x + 119 = 0 \qquad \text{simplified.} \\ \text{Here} \quad & b^2 - 4ac = 48^2 - 4(5)(119) = -76. \end{aligned}$$

The values of  $x$  are imaginary: *the loci do not meet.*

**§ 233. Factorability of a Quadratic.** If we subtract from  $x$  each of the roots in (2), multiply the resulting expressions, and simplify, we find

$$\left(x - \frac{-b + \sqrt{b^2 - 4ac}}{2a}\right) \left(x - \frac{-b - \sqrt{b^2 - 4ac}}{2a}\right) = \frac{1}{a}(ax^2 + bx + c).$$

That is,  $x$  minus each root is a factor of  $ax^2 + bx + c$ , the left member.

*E.g.*, if a quadratic has the roots  $3 + \sqrt{5}$ ,  $3 - \sqrt{5}$ , it has the factors  $(x - 3 - \sqrt{5})$ ,  $(x - 3 + \sqrt{5})$ .

Thus *every quadratic is factorable* into linear factors of some kind. These will be rational if the roots are, but not otherwise. Hence a sure test whether any quadratic is *rationally factorable* is to see whether  $(b^2 - 4ac)$  is a perfect square.

Ex. I. Test  $99x^2 - 42x - 16$ .

Here  $b^2 - 4ac = 8100$ . Hence the factors are rational. They can be found by inspection, or by writing  $x$  minus each root, by formula.

### EXERCISES

1. Determine the nature of the roots of the following:

- |                                |                                |
|--------------------------------|--------------------------------|
| (a) $9x^2 + 17x + 8 = 0$ ,     | (b) $12x^2 + 31x + 24 = 0$ ,   |
| (c) $x^2 - x - 1 = 0$ ,        | (d) $x^2 - x + 1 = 0$ ,        |
| (e) $18x^2 + 30x + 12.5 = 0$ , | (f) $72x^2 - 179x - 216 = 0$ . |

2. Without actually solving for the intersections determine whether the circle  $x^2 + y^2 - 3x + 7y + 6 = 0$  meets the  $X$  and  $Y$  axes.

3. Test the rational factorability of the following quadratic expressions. (The actual factors, if any, are not required.)

(a)  $11x^2 - 18x - 8,$

(b)  $12x^2 - 19x - 136,$

(c)  $388x^2 - 1164x + 813,$

(d)  $12x^2 - 42x + 27.$

4. For what value or values of  $k$  would the equation  $kx^2 - 6x + 4 = 0$  have equal roots? What are those roots?

5. The same as Ex. 4 for the equation  $2x^2 - 2kx + 4 - k = 0.$

6. The circle  $x^2 + y^2 - 8x - 14y + 1 = 0$  is cut by the line  $y = lx.$  Find the two intersections (in terms of  $l$ ). For what value of  $l$  would the two points come together, making the line tangent?

7. For what  $k$  will  $4y = 3x + k$  be tangent to  $x^2 + y^2 = 100?$

[8.] Divide  $2x^4 - 3x^3 + 7x^2 - 110x + 13$  by  $x - 4.$  Also substitute  $x = 4$  synthetically in the given quantity. Compare the synthetic substitution with your quotient and remainder.

§ 234. **Synthetic Division.** Before proceeding to solve equations of the third degree and above, we need to become familiar with a certain easy method of dividing out factors.

To see the underlying principle, divide the polynomial

$$f(x) = 4x^3 - x^2 - 19x + 10$$

by  $(x - 3),$  and compare with the synthetic substitution of 3 for  $x$  in the same  $f(x).$

$x - 3$	$4x^3 - x^2 - 19x + 10$	$4$	$-1$	$-19$	$+10$	$ $	$3$
	$4x^3 - 12x^2$			$12$	$33$		
	$11x^2 - 19x$						
	$11x^2 - 33x$						
	$14x + 10$						
	$14x - 42$						
	$52$						

By § 23 we know that the final sum in the substitution process (+52) is the value of  $f(x)$  when  $x = 3.$  But observe that it is also the *remainder* resulting from the division by  $(x - 3).$  Further, the other sums in the substitution (4, 11, 14) are precisely the *coefficients in the quotient.* Hence this

synthetic substitution could have been used as a quick and easy method of performing the division by  $(x-3)$ .

The reason the process works is simply this: In the substitution, we at each step multiply by 3, and *add*; whereas in the division, we multiply by  $-3$  and subtract.\*

Synthetic Substitution is also called "Synthetic Division," since it builds up the result of a division. Observe above that the leading coefficient (4) was brought down to give the complete quotient.

§ 235. **Integral Roots by Trial.** It will now be easy to find all the integral roots of an equation of any degree whatever. We have merely to test a few numbers as roots, and at the same time factor the given polynomial by Synthetic Division.

Ex. I. Solve  $4x^3 - x^2 - 19x + 10 = 0$ .

Substituting 2 synthetically gives zero as the final sum. Hence 2 is a root.

$$\begin{array}{r} 4 \quad -1 \quad -19 \quad +10 \quad | \quad 2 \\ \quad \quad \quad 8 \quad 14 \quad -10 \\ \hline 4 \quad +7 \quad -5 \end{array}$$

This substitution also shows that the remainder after dividing out  $(x-2)$  would be zero; and that the quotient would be  $4x^2 + 7x - 5$ . Hence the original equation, factored, is

$$(x-2)(4x^2 + 7x - 5) = 0.$$

Setting the factor  $4x^2 + 7x - 5$  equal to zero gives two more roots:

$$x = \frac{-7 \pm \sqrt{129}}{8}.$$

There can be no further roots; for any value of  $x$  that reduces the original polynomial to zero must make one of the factors zero.

\* For a formal proof that a similar process will always work, see the Appendix, p. 487.

In this example we could have told in advance that any integer, such as 3, which is not a factor of 10, could not be a root of this equation. For multiplying the next to the last sum (an integer) by 3 could not furnish the  $-10$  necessary to produce the final zero.

Likewise, in any other case, *the only possibilities for integral roots will be the divisors of the final term*, — providing the equation has been cleared of fractions.

Ex. II. Factor  $x^4 - 17x^2 - 34x - 30$ .

The only possible integral roots are  $\pm 1, \pm 2, \pm 3, \pm 5, \pm 6, \pm 10, \pm 15, \pm 30$ . And the test of 5 shows there can be no root above 5. (§ 23.)

Since 5 is a root, we divide out  $(x-5)$ , and test the quotient. Similarly, we divide out  $(x+3)$  and solve the remaining quadratic.

$$\begin{array}{r} 1 \quad 0 \quad -17 \quad -34 \quad -30 \quad \underline{5} \\ \phantom{1} \quad 5 \quad 25 \quad 40 \quad 30 \\ \hline 1 \quad +5 \quad +8 \quad +6 \quad \phantom{0} \quad \underline{-3} \\ \phantom{1} \quad -3 \quad -6 \quad -6 \\ \hline 1 \quad +2 \quad +2 \end{array}$$

$$x^2 + 2x + 2 = 0 \text{ gives } x = \frac{-2 \pm \sqrt{-4}}{2} = -1 \pm \sqrt{-1}.$$

Roots:  $5, -3, -1 + \sqrt{-1}, -1 - \sqrt{-1}.$   
 Factors:  $(x-5), (x+3), (x+1-\sqrt{-1}), (x+1+\sqrt{-1}).$   
 Lowest rational factors:  $(x-5), (x+3), (x^2+2x+2).$

§ 236. **Fractional Roots by Trial.** Some equations have fractional roots. It is easy to tell in any such case what fractions need be tested.

To get the idea let us see, for instance, under what conditions  $\frac{3}{2}$  might be a root of any equation

$$ax^n + bx^{n-1} + \dots + k = 0,$$

in which the coefficients  $a, b, \dots, k$ , are all integers.

Substituting synthetically, let  $S$  denote the next to the last sum :

$$\begin{array}{r} a \quad +b \quad \dots ( ) \quad +k \quad \underline{\frac{3}{2}} \\ \phantom{a} \quad +\frac{3}{2}a \quad ( ) \quad +\frac{3}{2}S \\ \hline a + (b + \frac{3}{2}a) \dots S + (k + \frac{3}{2}S) \end{array}$$



For  $\frac{3}{2}$  to be a root, we must have

$$k + \frac{3}{2} S = 0, \quad \text{or} \quad S = -\frac{2}{3} k.$$

Now,  $S$  cannot be a fraction with the denominator 3; for at no step could this denominator be introduced. Hence 3 must be a divisor of  $k$ .

Again, the first multiplication introduces a fraction, — which will persist and prevent a final zero, — unless 2 is a divisor of  $a$ .

Thus  $\frac{3}{2}$  can be a root of an equation only if *the numerator is a divisor of the constant term ( $k$ ), and the denominator is a divisor of the leading coefficient ( $a$ )*. Similarly for any other fraction  $p/q$ .

Ex. I.  $15x^6 - 19x^5 + 7x^3 - 11x^2 + 4 = 0.$

The only possible fractional roots are those whose numerators are factors of 4, and whose denominators are factors of 15:

$$\frac{1}{3}, \frac{2}{3}, \frac{4}{3}; \quad \frac{1}{5}, \frac{2}{5}, \frac{4}{5}; \quad \frac{1}{15}, \frac{2}{15}, \frac{4}{15};$$

and their negatives. A test shows  $\frac{2}{3}$  to be a root:

$$\begin{array}{r} 15 \quad -19 \quad +0 \quad +7 \quad -11 \quad +0 \quad +4 \quad \underline{1} \frac{2}{3} \\ \quad \quad 10 \quad -6 \quad -4 \quad \quad 2 \quad -6 \quad -4 \\ \hline 15 \quad -9 \quad -6 \quad +3 \quad -9 \quad -6 \end{array}$$

The remaining equation is, after canceling a factor 3,

$$5x^5 - 3x^4 - 2x^3 + x^2 - 3x - 2 = 0.$$

The only possibilities now are  $\pm\frac{1}{5}, \pm\frac{2}{5}, \pm 1, \pm 2$ .

None of these is a root. Hence any further roots must be imaginary or irrational.

Ex. II.  $x^3 + 17x^2 + 6x - 24 = 0.$

The leading coefficient is 1. The only possible "fractional" roots have a denominator 1, and must be *integers*.

### EXERCISES

1. Find all the roots of the following equations:

- (a)  $x^3 - 13x + 12 = 0,$  (b)  $x^3 - 2x^2 - x + 2 = 0,$   
 (c)  $x^4 + 2x^3 - 26x^2 + 27x + 18 = 0,$  (d)  $x^4 - 35x^2 - 90x - 56 = 0,$   
 (e)  $x^5 - 12x^3 - 46x^2 - 85x - 50 = 0,$  (f)  $x^5 - 20x^2 - 441x - 420 = 0,$

$$(g) \quad 9x^4 - 3x^3 + 7x^2 - 3x - 2 = 0, \quad (h) \quad 6x^3 + 13x^2 - 14x + 3 = 0,$$

$$(i) \quad 4x^4 + 8x^3 - 9x^2 - 24x - 9 = 0, \quad (j) \quad 4x^4 - 11x^2 + 65x - 30 = 0.$$

2. Find all the roots and rational factors of

$$(a) \quad 2x^3 - 21x^2 + 74x - 85 = 0, \quad (b) \quad 3x^3 + 11x + 14 = 0,$$

$$(c) \quad 36x^4 - x^2 - 2x - 1 = 0, \quad (d) \quad 4x^4 - 4x^3 + x^2 - 4x - 3 = 0,$$

$$(e) \quad 6x^4 + 5x^3 + 28x^2 - 6x - 5 = 0, \quad (f) \quad x^5 - 3x^4 + 4x^3 - 4x^2 + 3x - 1 = 0.$$

3. Find the lowest rational factors of  $16x^4 + 24x^3 + 8x^2 + 2x + 1$ .

4. The same as Ex. 3 for  $4x^5 + 8x^4 - 41x^3 + 10x^2 + 20x - 8$ .

5. The deflection of a loaded beam  $x$  feet from one end was  $y = k(2x^4 - 30x^3 + 1000x)$ . At what value of  $x$  was  $y$  a maximum?

6. The same as Ex. 5 if  $y = k(x^4 - 40x^3 + 480x^2 - 1600x)$ .

7. The rate of rotation of a flywheel ( $R$  deg./sec.)  $t$  sec. after the power was cut off was  $R = t^3 - 75t + 250$ . Find when the wheel stopped.

[8.] Plot  $y = x^3 + 3x^2 - 3x - 18$ , from  $x = -4$  to  $+5$ . What root has the polynomial? What would be the equation of this curve if translated two units to the left? (Multiply out.) What would the former root then become?

§ 237. **Further Roots.** When we have found by trial all the rational roots of an equation, any further roots must be *imaginary* or else real and *irrational*.

If imaginary, we cannot find them as yet, unless the equation is in quadratic form or easily factorable into quadratic forms. But if merely irrational, we can at least approximate them, — roughly by a graph, and then more closely by successive substitutions near the supposed root.

In treatises on the Theory of Equations it is proved that every polynomial of degree  $n$  has precisely  $n$  linear factors, real or imaginary, — and hence  $n$  roots. (Some of the factors may be equal; likewise the roots.)

Also it is proved that, if the given coefficients are real, any imaginary roots must occur in pairs, like  $3 + \sqrt{-2}$  and  $3 - \sqrt{-2}$ , etc.

## (B) METHODS OF APPROXIMATE SOLUTION

§ 238. **Diminishing a Root.** The labor involved in approximating an irrational root closely can be minimized by a simple device.

Suppose, for example, that the unknown root is 2.1768 ..., and that we have located it between 2 and 3. If we move the graph 2 units to the left, the root will be reduced to .1768. (Fig. 114.) We can easily locate it between .1 and .2 by testing these values. If we move the graph .1 more, the root will be .0768 .... We can locate it by testing .07 and .08; and the multiplications involved will be far simpler than if we were testing 2.17 and 2.18.

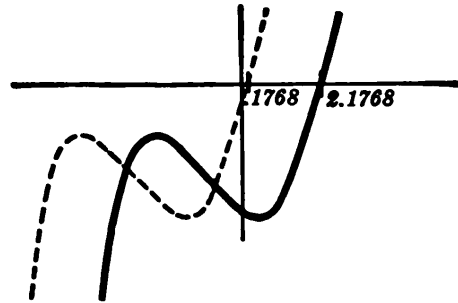

FIG. 114.

By continuing to move the graph we can make each successive test by using *a multiplier of a single digit* rather than several digits.

To make this device the more effective we shall now find a very quick method of getting the new equation of the graph after each successive translation.

### § 239. Translating a Graph Synthetically.

**THEOREM:** If the graph of any polynomial  $y = f(x)$  is moved  $h$  units to the left, the coefficients in the new equation will be simply *the remainders which would result from dividing  $f(x)$  synthetically by  $(x-h)$ , the quotient by  $(x-h)$ , the new quotient by  $(x-h)$ , and so on.*

**PROOF:** Let the new equation be

$$y = x^n + ax^{n-1} \dots + bx^2 + cx + d.$$

Now, whatever values the new coefficients  $a$ , ...  $b$ ,  $c$ , and  $d$  may have, they must be such that, if the graph were moved back  $h$  units to the right, replacing each  $x$  by  $(x-h)$ , we should get back the original equation  $y = f(x)$ . Hence

$$f(x) = (x-h)^n + a(x-h)^{n-1} \dots + b(x-h) + c(x-h) + d.$$

Clearly, then, dividing the original polynomial  $f(x)$  by  $(x-h)$  would give a remainder equal to  $d$ , the quotient being

$$Q = (x-h)^{n-1} + a(x-h)^{n-2} \dots + b(x-h) + c.$$

Again, dividing  $Q$  by  $(x-h)$  would give  $c$  as the remainder, with

$$Q' = (x-h)^{n-2} + a(x-h)^{n-3} \dots + b$$

as the next quotient. Dividing this by  $(x-h)$  would give  $b$  as the remainder. And so on for the other coefficients. (Q.E.D.)

To illustrate the actual working of the process, let us move the graph of  $y = x^3 + 3x^2 - 3x - 18$  two units to the left:

Dividing $f(x)$ by $(x-2)$ :	1	+3	- 3	-18	2
quotient, $Q = x^2 + 5x + 7$		+2	+10	+14	
remainder, -4	1	+5	+ 7	- 4	

Dividing $Q$ by $(x-2)$ :	1	+5	+ 7	2
quotient, $Q' = x + 7$		+2	+14	
remainder, 21	1	+7	+21	

Dividing $Q'$ by $(x-2)$ :	1	+7	2
quotient, = 1		+2	
remainder, 9	1	+9	

These remainders, 9, 21, -4, are the coefficients in the new equation which results from translating the graph, — viz.,

$$y = x^3 + 9x^2 + 21x - 4.$$

*Remarks.* (I) In practice the calculation can be condensed and made rapidly, as shown here.

New function :

$$x^3 + 9x^2 + 21x - 4.$$

1	+3	-3	-18	2
	+2	+10	+14	
1	+5	+ 7	-4	
	+2	+14		
1	+7	+21		
	+2			
1	+9			

(II) Another statement of this process is that the new coefficients are found by *substituting 2 for  $x$*  in the original  $f(x)$  and in the quotients resulting from successive divisions by  $(x-2)$ .

§ 240. **Horner's Method, Complete.** Let us now see how the foregoing process works in solving an equation.

ILLUSTRATION:  $x^3 + 3x^2 - 3x - 18 = 0$ .

I (A) Plot the graph: (B) Move graph 2 units (left):

4 units below at $x=2$ ,	1	+3	- 3	- 18	2
27 units above at $x=3$ .		+2	+10	+14	
Hence, a root near 2.1.*	1	+5	+ 7	- 4	
After moving the graph,		+2	+14		
the root will be near .1.	1	+7	+21		
		+2			
	1	+9			

New  $f(x) = x^3 + 9x^2 + 21x - 4$ .

II (A) Test new  $f(x)$  at .1, etc., by substitution:

(B) Move graph .1 unit (left):

1.809 below at $x=.1$ .	1	+9	+21	-4	.1
.568 above at $x=.2$ .		+ .1	+ .91	+2.191	
Hence, a root near .17.	1	+9.1	+21.91	-1.809	
After moving the graph,		+ .1	+ .92		
the root will be near .07.	1	+9.2	+22.83		
		+ .1			
	1	+9.3			

III (A) New  $f(x) = x^3 + 9.3x^2 + 22.83x - 1.809$ . Testing shows a root between .07 and .08, — near .077.

(B) Moving the graph .07 to the left, the root should be near .007.

IV (A) New  $f(x) = x^3 + 9.51x^2 + 24.1467x - .164987$ . Testing shows a root between .007 and .006, — near .0068.

(B) Moving the graph .006 to the left, the root should be near .0008.

V New  $f(x) = x^3 + 9.528x^2 + 24.260928x - .019764224$ .

\* This estimate is made roughly by inspection: comparing the values 4 and 27 indicates that the crossing is several times as far from  $x=3$  as from  $x=2$ .

Instead of continuing as above we can now get some further figures in the root as follows. Since  $x$  is now very small, the terms  $x^3$  and  $9.528 x^2$  are practically negligible. Ignoring them, our equation is approximately:

$$24.260928 x - .019764224 = 0.$$

By ordinary division this gives

$$x = .0008146+.$$

Recalling the several translations, the original root is

$$x = 2.1768146+.$$

*Remarks.* (I) To test both at  $x=2$  and at  $x=3$  before translating the graph 2 units was very important. This not only insured us against moving the curve a wrong amount, but also showed about *how many tenths* to test in the next stage. For similar reasons, at every stage, we make tests until the root is *definitely located*.

Plotting the graph is not essential; but we should determine whether it would rise or fall near the root sought.

(II) To approximate *negative* roots, slide the curve to the *right*. To do this, use negative substitutions instead of positive.

Another method is to change the sign of  $x$  throughout the given equation, and then seek positive roots of the new equation.

(III) After  $n$  figures of a root have been found by testing, and the next  $f(x)$  has been obtained, approximately  $n$  more figures can be obtained by a simple division, as in the last step above.

(IV) This method of approximating irrational roots was invented about 1820 by W. G. Horner, an Englishman. It applies only to equations in the standard polynomial form; but is the best known method for such equations, and is much used.

### EXERCISES

1. Move the curve  $y = x^2 - 6x + 7$  three units to the left, using the synthetic process. Check by "translators."
2. Find to 6 decimals the root of  $x^3 - 20x + 8 = 0$  which lies between 4 and 5. (Hint: Get the last three places by division.)
3. In Ex. 2 locate the other roots and approximate each to 4 decimals.

4. Locate graphically the real roots of  $x^3 - 5x + 1 = 0$ , and approximate one of them to 4 decimals.

5. In Ex. 4 approximate the other roots to two decimals.

6. Show graphically that the equation  $x^3 + 2x^2 - 23x - 70 = 0$  has only one real root. Approximate this to six decimals.

7. What are the possibilities as regards the number of real and imaginary roots for an equation of degree two? three? four? If you had found one real unrepeatd root of a quartic equation could you draw any conclusion as to the other roots?

8. Approximate to four decimals every real root of  $x^4 + x^3 + x - 1 = 0$ .

9. Solve  $x^3 - 12 = 0$  by Horner's method to four decimals and check directly.

10. The "index of correlation" between the eye-colors of a certain group of people and of their great-grandparents is approximately a root, between 0 and 1, of the equation:  $.024x^4 + .137x^3 + .035x^2 + x - .225 = 0$ . Find  $x$  to two decimals. [C. B. Davenport.]

11. The diameter ( $d$  in.) of the bolts needed in certain cylindrical shafts is a root of the equation  $d^4 + 800d^2 - 18d - 360 = 0$ . Find  $d$  to two decimal places.

12. At what point on the curve  $y = x^4 - 8x^2 + 3x + 10$  is the slope equal to  $+35$ ?

13. Where should an ordinate be erected to the parabola  $y = x^2 + 10$  to make the area under the curve between the  $Y$ -axis and the ordinate 100 square units?

14. The greatest and least distances of Jupiter's Fifth Satellite from the center of the planet are approximately roots of the equation  $x^3 - 5x^2 + 6.27396x - .060385 = 0$ , the unit of distance being Jupiter's radius, 45090 miles. Find those roots to 3 decimal places.

15. A magnet placed with its ends in a "magnetic meridian" will neutralize the earth's magnetism at certain points. To calculate the position of these points in a certain case, it was necessary to solve the equation:

$$\frac{20000x}{(x^2 - 100)^2} = .2.$$

Simplify and solve. (There are two values, — one large and one small.)

§ 241. **Newton's Method.** Another excellent method of approximating irrational roots, which can be used even for equations that involve trigonometric and exponential func-

tions, etc., was invented by Sir Isaac Newton. It does not move the graph, but works throughout with the original  $f(x)$  and the derivative  $f'(x)$ . An example will show the idea.

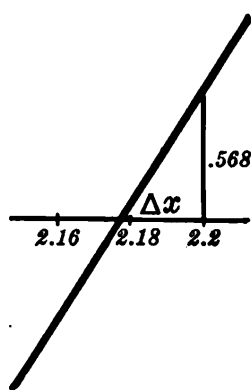

FIG. 114 a.

Ex. I.  $x^3 + 3x^2 - 3x - 18 = 0.$

The graph shows a root near 2.2. (Fig. 114, p. 335.) Substituting this value in the given function and in the derivative  $3x^2 + 6x - 3$  gives as the height and slope at that point:

$$y = .568, \quad \text{slope} = 24.72.$$

To reach the crossing, we must evidently go back to the left some horizontal distance  $\Delta x$ . Assuming the graph practically straight that far, the slope is approximately  $.568/\Delta x$ .

$$\therefore \frac{.568}{\Delta x} = 24.72, \text{ whence } \Delta x = .023, \text{ approx.}$$

Subtracting  $\Delta x$  from 2.2 gives 2.177 as the root.

Repeating the operation with this result as a starting point instead of 2.2 would give a very fine approximation.

**§ 242. Isolating the Roots.** We can approximate closely the irrational roots of an equation, — provided we can first locate them roughly.

Systematic substitutions will usually show any change of sign in  $f(x)$ . But suppose there were two roots between 2 and 3, so that the graph should cross and recross in this interval, leaving  $f(x)$  positive both at  $x=2$  and at  $x=3$ . We might not discover that the graph ought to cross at all.

Such double crossings can usually be detected by calculus. For between the crossings there will be a maximum or minimum height, — at which  $f'(x) = 0$ . *If we can solve this "derived equation,"*  $f'(x) = 0$ , we can find all the maxima and minima, and thus discover that the curve has crossed and recrossed.



A sure test in all cases, — which was invented about 1830 by J. C. F. Sturm, a Swiss, — is given in treatises on the Theory of Equations. The methods suggested above suffice, however, for almost all practical problems.

## EXERCISES

1. Starting from the result of Ex. I, § 241, find the crossing still more closely by the same method. (Cf. the value in § 240, p. 338.)
2. Solve  $x^7 - 144 = 0$  approximately by Newton's method, — in one step, starting from  $x = 2$ . Check by logarithmic calculation.
3. Find by Newton's method the largest root of  $2x^3 - 15x + 10 = 0$ . (Cf. § 21.)
4. Find graphically the real roots of  $3x^3 - 27x + 31 = 0$ . Make a sure test whether the minimum  $y$  is positive or negative.

§ 243. **Summary of Chapter IX.** The new methods of solving equations which have been developed in this chapter are of two kinds.

(A) *Exact solutions.* Finding the roots of a quadratic by formula, and the rational roots of any equation by trial substitutions and removal of factors.

(B) *Approximate solutions.* Finding the irrational roots of an equation by Horner's or Newton's method.

*Remark.* We have taken up the solution of equations immediately after Cartesian geometry because of the close relationship between these two topics. *E.g.*, the idea of translating a curve underlies Horner's method, and conversely, the formula for the roots of a quadratic is very useful in analytical geometry in studying tangent lines, etc.

We shall now return to the field of analytic geometry and consider another system of coördinates which is very useful in many practical problems.

## EXERCISES

1. Approximate by Newton's method the largest root of
 
$$x^3 - 7x + 5 = 0.$$
2. Check the answer to Ex. 1 by Horner's method.
3. The diameter of a pipe ( $x$  in.) which will discharge water at a

certain rate under a certain pressure is a root of the equation:  $x^5 - 38x - 101 = 0$ . [M. Merriman.] Find that root to two decimals.

4. Find any rational roots exactly, and approximate any irrational real roots to two decimals:

(a)  $16x^4 - 24x^3 + 8x^2 - 2x + 1 = 0$ ,

(b)  $4x^5 - 8x^4 - 41x^3 - 10x^2 + 20x + 8 = 0$ .

5. Factor into their lowest rational factors:

(a)  $8x^4 + 12x^3 - 10x^2 - 29x - 15$ ,

(b)  $16x^5 - 40x^4 - 104x^3 + 194x^2 - 101x + 35$ ,

(c)  $x^8 - 10x^6 + 16x^5 - 16x^3 + 10x^2 - 1$ .

6. Solve graphically the simultaneous equations  $x^2 + y = 11$ ,  $x + y^2 = 7$ .

7. Solve the equations in Ex. 6 algebraically, finding the irrational roots to 1 decimal.

8. In how many years would \$1000 with 8% interest compounded quarterly amount to the same as \$2000 with 4% interest compounded semi-annually plus \$3000 with 2% interest compounded annually?

9. The rate of interest which a bond will net if purchased at a certain price is given by  $900x^{21} - 925x^{20} - 1000x + 1025 = 0$ ,  $x$  being  $1 + r/2$ . Solve this equation approximately by Newton's method.

10. What is the nature of the roots of  $4x^2 - 7x - 2 = 0$ ?

11. Solve for  $x$ :  $e^x + 10e^{-x} = 7$ . (Hint: Let  $e^x = y$ .)

12. For what value of  $r$  would the circle  $x^2 + y^2 = r^2$  be tangent to the line  $y = 3x - 10$ ? (Cf. p. 330, Ex. 6, 7.)

13. Solve by Newton's method:  $2x - \log_e x = 5$ .

14. Find the area under the curve  $y = 1 + 1/x$ , from  $x = 1$  to  $x = X$ . For what value of  $X$  is  $A = 7$ ?

15. Where is the slope of the curve  $y = x^2 + e^x$  equal to 10?

# CHAPTER X

## POLAR COÖRDINATES AND TRIGONOMETRIC FUNCTIONS

### PERIODIC VARIATION

**§ 244. Locating Points.** In daily affairs we frequently describe the location of a point by telling *how far it is from some known point, and in what direction.*

For instance, we say that a certain town is “20 miles from here in a direction  $12^\circ$  north of east.”

The same idea is used extensively in Mathematics. A fixed point  $O$  is chosen as origin or “pole”; and a fixed line  $OA$  as a direction axis. Any point  $P$  is then definitely located, as soon as we know the distance  $OP$  and the angle  $AOP$ . (Fig. 115.)

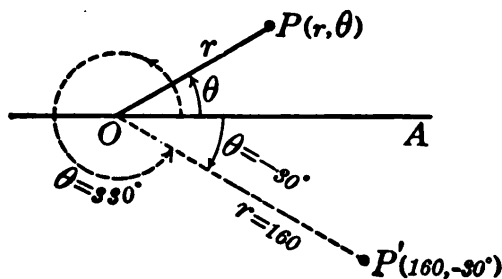

FIG. 115.

$OP$  is called the *radius vector* of  $P$ ; and is denoted by  $r$ .

$\angle AOP$  is called the *longitude* or *vectorial angle* of  $P$ , and is denoted by  $\theta$  (Greek letter *theta*).

The two values  $(r, \theta)$  are called the *polar coordinates* of  $P$ .

If  $P$  moves around  $O$  continually,  $\theta$  will increase up to  $360^\circ$ , — and beyond, if we consider the whole angle turned. Thus angles of any size whatever may arise in considering rotary motion.

**§ 245. Positive and Negative Angles.**  $\theta$  is always measured *from* the "polar axis"  $OA$  to the radius vector  $OP$ , — usually in the counterclockwise direction. When measured clockwise,  $\theta$  is regarded as negative. Thus in Fig. 115,  $P'$  has  $\theta = 330^\circ$  or  $-30^\circ$ , and thus has the coördinates  $(160, 330^\circ)$  or  $(160, -30^\circ)$ .

Merely adding  $360^\circ$  to  $\theta$  will not change the position of a point. Thus any given point has innumerable sets of coördinates, the  $\theta$  values differing by multiples of  $360^\circ$ , but  $r$  having a single positive value, the distance  $OP$ .\*

To plot a point when given its polar coördinates, simply construct  $\theta$  by protractor, and lay off  $r$ . Or use "polar plotting paper." (Fig. 127, p. 366.)

Notice the resemblance of this paper to a circumpolar map of the earth, with the meridians radiating from the pole and cut by the parallel circles of latitude.

**§ 246. Path of a Moving Point.** If we know the values of  $r$  and  $\theta$  for a moving point at various times, we can plot the corresponding positions, and obtain the approximate path.

The distance traveled during any interval can be estimated by rolling a ruler along the path.

### EXERCISES

1. The polar coördinates of five snow-peaks visible from Portland, Ore., are  $(104, 66^\circ)$ ,  $(53, 62^\circ 30')$ ,  $(75, 39^\circ 30')$ ,  $(51, -14^\circ)$ , and  $(74, -53^\circ)$ ,  $r$  being in miles and  $\theta$  being measured from the east (toward the north, if plus). Plot these points. Calculate the distance between the last two; and check by measurement.

2. A golf ball driven from  $(0, 0^\circ)$  for a flag at  $(400, 0^\circ)$  came to rest at  $(210, 10^\circ)$ . How far was it from the flag?

3. Halley's comet was nearest the sun in April, 1910. Its position then and after various intervals ( $t$  yrs.) is shown in Table 1. (The sun

\* Negative values of  $r$  can be given an interpretation as in Ex. 7 below, which is useful in certain kinds of work.

is at the origin; and the unit distance is the mean distance from the earth to the sun.) Plot these positions and draw the path, — a half-ellipse. About what  $r$  and  $\theta$  has the comet now, apparently? Estimate the distance traveled in the ten-year period,  $t=28$  to  $38$ ; also in the first year.

4. On Jan. 1, 1913, the coördinates of the planets were: Merc. (.41,  $195^\circ 13'$ ), Venus (.72,  $30^\circ 45'$ ), Earth (.98,  $100^\circ 30'$ ), Mars (1.49,  $252^\circ 34'$ ), Jup. (5.26,  $267^\circ 42'$ ), Sat. (9.07,  $62^\circ 6'$ ), Ur. (19.8,  $303^\circ 14'$ ) Nep. (30,  $114^\circ 34'$ ).

Plot these positions. Estimate and calculate the distance from Jupiter to Uranus.

5. A point  $P$  moved so that  $r=50$  always and  $\theta=3t^2$  after  $t$  sec. Mark the positions of  $P$  at  $t=0, 1, 2, \dots, 10$ . Find the rate of rotation (in degrees per sec.) at  $t=5$ .

6. A point moved so that  $r=2t$  and  $\theta=60t$  after  $t$  sec. Plot the path from  $t=0$  to  $t=10$ .

7. Let negative values of  $r$  be laid off from the pole in the *reverse* of the direction indicated by the value of  $\theta$ . Then the point  $\theta=17^\circ$ ,  $r=-10$  is the same as  $\theta=197^\circ$ ,  $r=+10$ . Plot this and the following points:  $(-10, 80^\circ)$ ,  $(-5, 160^\circ)$ ,  $(-8, 240^\circ)$ ,  $(-20, 340^\circ)$ . How could each point be designated with  $r$  positive?

§ 247. **Circular Motion.** Polar coördinates are especially suited to the study of circular motion:  $r$  remains constant, and we have only to consider how  $\theta$  varies.

The rate at which  $\theta$  is increasing, — say the number of degrees per sec., — is the rate at which the radius  $OP$  is turning. (Fig. 116.) This is called the *angular speed* of  $P$ ; and is denoted by the Greek letter  $\omega$  (*omega*).

From  $\omega$  we can find how fast  $P$  is moving, — say in feet per sec., — in other words, the *linear speed* of  $P$ .

Ex. I. A point  $P$  moved in a circle of radius 5 ft. so that

$$\theta = .1 t^3 - .002 t^4,$$

TABLE 1

$t$	$r$	$\theta$
0	.59	0
$\frac{1}{2}$	.87	$70^\circ 30'$
$\frac{1}{2}$	3.08	$130^\circ$
1	5.01	$142^\circ 38'$
3	10.4	$156^\circ 43'$
8	19.0	$166^\circ 8'$
18	28.9	$172^\circ 54'$
28	33.8	$176^\circ 48'$
38	35.4	$180^\circ$

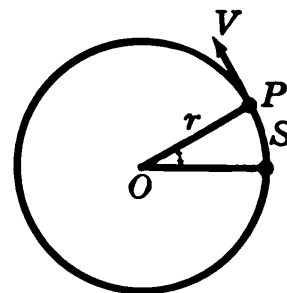

FIG. 116.

$\theta$  being in degrees, and  $t$  in seconds. Find the position and speed of  $P$  when  $t = 20$ .

$$\theta = .1(20^3) - .002(20^4) = 480 \text{ at } t = 20.$$

That is, the radius  $OP$  had then turned  $480^\circ$  since starting.

$$\omega = \frac{d\theta}{dt} = .3 t^2 - .008 t^3, \quad = 56 \text{ at } t = 20.$$

That is,  $OP$  was then turning at the rate of 56 deg./sec. Hence  $P$  was moving at the rate of  $\frac{56}{360}$  of a circumference per sec., *i.e.*, with the speed

$$v = \frac{56}{360}(10\pi) \text{ ft./sec.}, \quad = 4.89 \text{ ft./sec.}$$

**§ 248. Angular and Tangential Acceleration.** The rate at which the angular speed  $\omega$  is increasing is called the *angular acceleration*. It is denoted by the Greek letter  $\alpha$  (*alpha*).

$$\alpha = \frac{d\omega}{dt} = \frac{d^2\theta}{dt^2}.$$

The rate at which the linear speed  $v$  is changing is called the linear acceleration in the direction of motion, or the *tangential acceleration*,  $a_t$ .\*

Like  $v$ ,  $a_t$  refers to the actual motion of  $P$  along the path; whereas  $\alpha$ , like  $\omega$ , refers only to the rotation of the radius  $OP$ , though called the angular acceleration of  $P$ .

For instance, in Ex. I of § 247, we should have

$$a = \frac{d^2\theta}{dt^2} = .6 t - .024 t^2, \quad = 2.4 \text{ at } t = 20.$$

That is, the rotational speed of the line  $OP$  is increasing at the rate of 2.4 deg./sec<sup>2</sup>. Hence the linear speed of the point  $P$  is increasing at the rate of 2.4/360 of a circumference per sec<sup>2</sup>., or

$$a_t = \frac{dv}{dt} = \frac{2.4}{360} (10\pi) \text{ ft./sec}^2.$$

\* This is usually not the total acceleration, as defined in Physics. For in curved motion there is an acceleration perpendicular to the path, — which changes the *direction* of motion, — as well as the acceleration  $a_t$  along the path, which changes the *speed*.

## EXERCISES

1. A point moved in a circle so that  $\theta = .2 t^2$  (degrees). Find  $\omega$  and  $\alpha$  when  $t = 5$  (seconds).

2. A point moved in a circle of radius 20 in. so that  $\theta = 2 t^2 - .05 t^3$  (degrees). Find the speed and the distance traveled at  $t = 20$ .

3. For 30 seconds a wheel turned so that  $\theta = .03 t^3 - .0005 t^4$  (degrees), after which the speed remained constant. Find the angular speed and acceleration when  $t = 10$ .

4. A wheel of radius 5 ft. started from rest in such a way that  $d^2\theta/dt^2 = 24 t - 6 t^2$ , where  $\theta$  is in revolutions and  $t$  in minutes. Find  $\theta$  and  $\omega$  and the distance traveled by a point on the rim when  $t = 5$ .

5. A point moves in a circle of radius 10 in. in such a way that  $\theta = 90 t^2 - t^3$  (degrees). Find the maximum speed of the point.

[6.] How long an arc is intercepted in any circle by a central angle of  $1^\circ$ ? How large a central angle will intercept an arc equal to the radius?

§ 249. **Radians.** An angle which if placed at the center of a circle would intercept an arc exactly equal to the radius is called a *radian*, — written  $1^{(r)}$ . (Fig. 117.)

Since the radius is contained precisely  $\pi$  times in a semicircumference, there are  $\pi$  radians in a central angle of  $180^\circ$ :

$$\pi^{(r)} = 180^\circ. \quad (1)$$

Dividing both sides of this by  $\pi$ , or 3.1416 approx.,

$$1^{(r)} = 57^\circ 17' 44''.6.$$

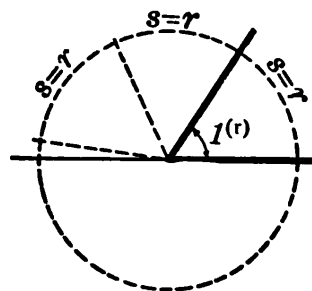

FIG. 117.

Since a radian is an angle of perfectly definite size, we can measure any other angle by the number of radians it contains, just as well as by the number of degrees. This greatly simplifies the study of circular motion.

*E.g.*, for every radian through which line  $OP$  turns (Fig. 116), the point  $P$  travels a distance equal to the radius. If the angular speed is 4 radians per sec.,  $P$  is moving with a speed of 4 radii per sec.\*

\* Do not confuse a *radian* with a *radius*. A radian is not an arc or line but an *angle*. (Exactly what angle?)

**§ 250. Tables of Equivalents.** By the tables on p. 504 of the Appendix, we can quickly convert any number of radians into degrees, or *vice versa*. The following examples show the reduction of  $2.16^{(r)}$  to degrees; and of  $7^\circ 12' 45''$  to radians.

$2.^{(r)}$	$114^\circ$	$35'$	$30''$	$7^\circ = 7 \times .017453^{(r)} = .12217^{(r)}$
.1	5	43	46	$12' = 12 \times .000291 = .00349$
.06	3	26	16	$45'' = 45 \times .000005 = .00022$
2.16	$123^\circ$	$45'$	$32''$	$7^\circ 12' 45'' = .12588^{(r)}$

Any simple fraction of  $\pi^{(r)}$  or  $180^\circ$  is best transformed without the tables. *E.g.*,

$$\frac{\pi}{6}^{(r)} = 30^\circ,$$

$$90^\circ = \frac{\pi}{2}^{(r)}.$$

### EXERCISES

1. In a circle of radius 30 in., find the lengths of the arcs intercepted by central angles of  $3^{(r)}$ ,  $1.85^{(r)}$ , and  $.08651^{(r)}$ .
2. A wheel of radius 10 in. is turning with an angular speed of 3 rad./min. What is the speed of a point on its rim?
3. If the same wheel turns so that  $\theta = .2 t^2$  (radians), find the speed and tangential acceleration of a point on the rim, when  $t = 5$ .
4. A wheel of radius 20 in. turned in such a way that, after  $t$  sec.,  $\theta = .0006 t^3 - .00001 t^4$  (radians.) Find the maximum speed attained by a point on the rim.
5. In Ex. 4 find the maximum tangential acceleration attained.
6. A wheel of radius 2 ft. had, after  $t$  sec., an angular speed  $\omega = .009 t^2 - .0002 t^3$  (rad./sec.). Find the angle turned and the distance traveled by a point on the rim from  $t = 0$  until the maximum speed was reached.
7. Without tables find the number of degrees in  $3^{(r)}$ ,  $.2^{(r)}$ ,  $\frac{\pi}{4}^{(r)}$ .
8. How many radians in  $90^\circ$ ? In  $1^\circ$ ? In  $17^\circ$ ?
9. Verify without tables the equivalents in § 250.
10. Using tables, find the equivalents of  $5^{(r)}$ ,  $2.37^{(r)}$ ,  $6.2832^{(r)}$ .
11. The same as Ex. 10 for  $\pi/6^{(r)}$ . Check without tables.
12. If a watch keeps correct time, what is the angular speed of the second hand in rad./sec.?
13. What is the angular speed of rotation of the earth in rad./sec.?



14. What is the linear speed of a point on the earth's equator, due only to the rotation? (Take the earth's radius as 3960 mi.)

15. The same as Ex. 14 for a point in latitude  $45^\circ 30'$ .

[16.] In any circle what is the length of an arc intercepted by a central angle of  $1''$ ?

§ 251. **Arc and Central Angle.** If a central angle in a circle contains  $\theta$  radians, its intercepted arc equals  $\theta$  times the radius :

$$s = r\theta. \quad (2)$$

This relation is much simpler than if the angle were expressed in degrees.

A central angle of  $1^\circ$  intercepts an arc equal to  $\frac{1}{360}(2\pi r)$ , or  $.01745329 r$ , approx. And for an angle of  $\theta^\circ$  the arc is

$$s = .01745329 r\theta. \quad (3)$$

Whatever the units of measure may be, the relation between the arc and the angle is always of this form :

$$s = k\theta, \quad (4)$$

$k$  being the length of arc intercepted by a *unit angle*, — whatever that may be.

§ 252. **Estimates Involving Very Small Angles.** By Ex. 16 above, a central angle of  $\theta''$  intercepts an arc whose length is

$$s = 4.85 \times 10^{-6} r\theta. \quad (5)$$

This formula is useful in making approximations involving very small angles, — as illustrated in the following example.

Ex. I. A comet subtends at the earth an angle of  $2''$  at a time when it is known to be one billion miles away. Find its approximate diameter.

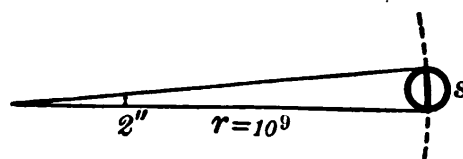

FIG. 118.

Imagine a circle to be drawn with a radius of one billion ( $=10^9$ ) miles, and with its center at the earth. (Fig. 118.) The part of its circumference intercepted by a central

angle of  $2''$  is relatively so short an arc as to be practically straight. That is, the arc would approximate the required diameter of the comet.

Substituting  $\theta = 2$  and  $r = 10^9$  in (5) gives

$$s = (4.85 \times 10^{-6}) \times 10^9 \times 2 = 9700.$$

The diameter of the comet is approximately 9700 miles.

*N.B.* The value of  $s$  in (5) will not approximate closely the distance between two points, unless the line joining them is practically perpendicular to the bisector of the angle.

### EXERCISES

1. Find the diameter of a sun-spot which, if viewed perpendicularly, would subtend at the earth (92,500,000 mi. away) an angle of  $40''$ .
2. Estimate the diameter of a crater on the moon, at the center of the disc, if it subtends at the earth (240,000 mi. away) an angle of  $100''$ .
3. How far away is Jupiter when its diameter (90,000 mi.) subtends at the earth an angle of  $40''$ ?
4. The distance of the earth from the sun subtends at the nearest fixed star an angle of  $0.''76$ , approx. Find the distance to the star.
5. How large an angle would the diameter of a dollar (1.5 in.) subtend at a distance of 6 miles? (Compare the angle in Ex. 4.)
6. Two ships crossing the same meridian have a difference of latitude of  $16' 40''$ . How far apart are they? (Take the earth's radius as 3960 mi.)
7. A mountain 10 mi. away has an elevation angle of  $.2^{(r)}$ . About how high is its summit above the observer?
8. A mountain rising 7500 ft. above an observer has an elevation angle of  $.15^{(r)}$ . How far away is it, roughly?
9. Find the angle which the earth's diameter would subtend if seen from the moon.
10. The same as Ex. 9, if seen from Mars when 80,000,000 mi. away.
11. Verify the values of  $k$  in (3) and (5) above for angles measured in degrees or seconds. Also find  $k$  for angles measured in minutes.
12. A flywheel of radius 5 ft. is turning at the rate of 8 rad./min. How fast is a point on the rim moving?

### TRIGONOMETRIC FUNCTIONS

§ 253. **General Definitions.** The functions sine, cosine tangent, etc., were defined in Chapter V for any acute angle

— as certain ratios of the sides of a right triangle containing the angle.

Evidently these definitions would be meaningless in the case of very large angles: we could not even get the angle into a right triangle, — much less speak of “the opposite leg,” etc. The definitions, however, can be restated now in such a way as to make them applicable to angles of any size, — and yet leave their meaning unaltered for acute angles.

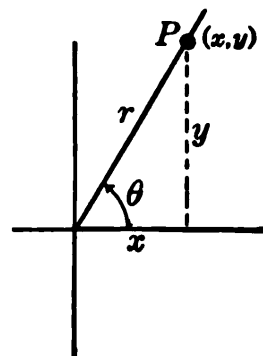

FIG. 119.

In the case of an acute angle (Fig. 119), the “adjacent leg” and “opposite leg” are simply  $x$  and  $y$ , — the rectangular coordinates of the point  $P$  referred to the axes shown. Hence the former definitions might now be stated as follows:

*Let the initial side of any angle  $\theta$  be taken as the X-axis, and the vertex as the origin; and let  $P(x, y)$  be any point on the terminal side of the angle. Then*

$$\sin \theta = \frac{y}{r} = \frac{\text{ordinate of } P}{\text{radius vector of } P'}$$

$$\cos \theta = \frac{x}{r} = \frac{\text{abscissa of } P}{\text{radius vector of } P'} \tag{6}$$

$$\tan \theta = \frac{y}{x} = \frac{\text{ordinate of } P}{\text{abscissa of } P}$$

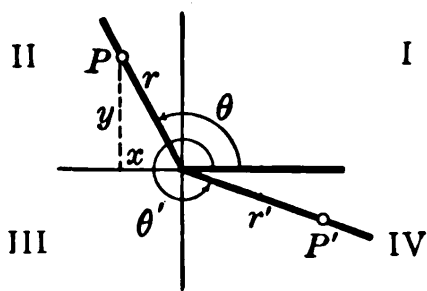

FIG. 120.

I These statements have a meaning even for very large angles, such as  $\theta$  and  $\theta'$  in Fig. 120. For no matter how large an angle is, any point  $P$  on its terminal line has some definite coordinates  $x$ ,  $y$ , and  $r$ .

The “quadrants” into which the  $X$  and  $Y$  axes divide the plane are numbered for convenience, starting from the positive  $X$ -axis and going counterclockwise. Angles between  $90^\circ$  and  $180^\circ$  are called “angles of the second quadrant.” And so on.

Each function defined above is positive in certain quadrants and negative in others. No rules are necessary as to this if you memorize thoroughly the definitions (6). Simply picture to yourself the position of  $P$  for any given angle  $\theta$ , and notice whether  $x$  and  $y$  are positive or negative:  $r$  is always positive.

**§ 254. Reciprocal Functions.** The reciprocals of the three functions above, in reverse order, are called the cotangent, secant, and cosecant, written *ctn*, *sec*, *csc*:

$$\begin{aligned} \sin \theta &= \frac{y}{r}, & \csc \theta &= \frac{r}{y}, \\ \cos \theta &= \frac{x}{r}, & \sec \theta &= \frac{r}{x}, \\ \tan \theta &= \frac{y}{x}, & \text{ctn } \theta &= \frac{x}{y}. \end{aligned} \quad (7)$$

To remember easily this pairing of reciprocals, practice reading the order down the first column and up the other.

Also observe that a co-function is never the reciprocal of a co-function.

**§ 255. Finding All from One.** Given any one function of an angle, you can find all the others, — without tables. Simply draw the angle and read off the desired values. Except for certain extreme cases, there are two possible sets of values, due to the fact that there are two angles in different quadrants, for each of which the given function has the specified value.

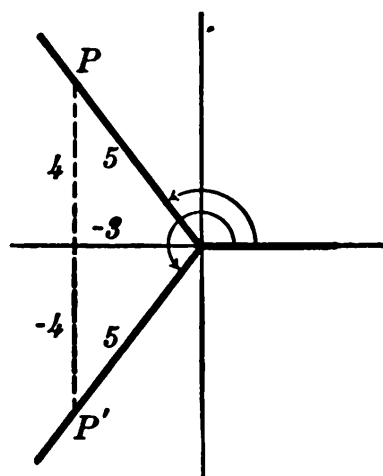

FIG. 121.

Ex. I.  $\cos \theta = -3/5$ . Find the other functions.

Here  $x/r = -3/5$  for every point on the terminal line. Taking  $r = 5$

requires  $x = -3$ . This is satisfied both at  $P$  and at  $P'$ , in Fig. 121. Thus  $\theta$  may be in either the second or third quadrant.

Quadrant II		Quadrant III	
$\sin \theta = 4/5,$	$\csc \theta = 5/4,$	$\sin \theta = -4/5,$	$\csc \theta = -5/4,$
$\cos \theta = -3/5,$	$\sec \theta = -5/3,$	$\cos \theta = -3/5,$	$\sec \theta = -5/3,$
$\tan \theta = -4/3,$	$\cot \theta = -3/4.$	$\tan \theta = 4/3,$	$\cot \theta = 3/4.$

Ex. II.  $\tan \theta = 3/2$ , but  $\theta > 90^\circ$  and  $< 360^\circ$ . Find  $\sin \theta$ ,  $\cos \theta$ .

Here  $y/x = 3/2$  for every point on the terminal line. Since  $\theta$  is not in Quadrant I, both  $x$  and  $y$  must be negative. Take  $x = -2$ ,  $y = -3$ . Then  $r = \sqrt{(-2)^2 + (-3)^2} = \sqrt{13}$ .

$$\therefore \sin \theta = -\frac{3}{\sqrt{13}}, \quad \cos \theta = \frac{2}{\sqrt{13}}.$$

### EXERCISES

1. Draw angles of  $160^\circ$ ,  $200^\circ$ , and  $340^\circ$ ; and by measuring lines calculate the approximate values of the six functions for each. List separately, noting  $+$  and  $-$  signs carefully.

2. Prove that for any obtuse angle (*i.e.*, between  $90^\circ$  and  $180^\circ$ ):

sine of obtuse angle = sine of supplementary acute angle;  
cosine of obtuse angle =  $-$  cosine of supplementary acute angle.

(Compare § 121.) How about the tangent of an obtuse angle?

3. Draw and measure the following angles:

- (a) between  $90^\circ$  and  $270^\circ$ , having  $\cot \theta = -1.50$ ,
- (b) between  $90^\circ$  and  $270^\circ$ , having  $\sin \theta = -.90$ ,
- (c) between  $180^\circ$  and  $360^\circ$ , having  $\sec \theta = 1.25$ .

4. Given each of the following functions, draw each possible angle  $< 360^\circ$ , and write by inspection the values of the five remaining functions, — listed separately:

- (a)  $\cos \theta = -5/13,$
- (b)  $\csc \theta = -5/4,$
- (c)  $\tan \theta = -3/4,$
- (d)  $\sin \theta = 3/4,$
- (e)  $\sec \theta = \sqrt{5}/2,$
- (f)  $\cot \theta = 4.$

5. Find approximate values of the six functions of  $-80^\circ$ . How do the sine and cosine of  $-80^\circ$  compare with the same functions of  $+80^\circ$ , numerically and as to sign? Is the same thing true for  $-130^\circ$  and  $+130^\circ$ ? For any  $-\theta$  and  $\theta$ ?

**§ 256. Special Angles.** The functions of any angle can be found approximately by measurement. For certain special angles they can also be calculated exactly by elementary geometry, *e.g.*, for angles which differ from  $180^\circ$  or  $360^\circ$  by  $30^\circ$ ,  $45^\circ$ , or  $60^\circ$ .

**Ex. I. Functions of  $300^\circ$ .**

Taking  $r=10$  gives  $x=5$ ,  $y=-5\sqrt{3}$ ; for the right triangle formed by  $x$ ,  $y$ , and  $r$  is half of an equilateral triangle. (Draw the figure.)

$$\begin{aligned}\therefore \sin \theta &= \frac{-5\sqrt{3}}{10} = -\frac{\sqrt{3}}{2}, \\ \cos \theta &= \frac{-5}{10} = -\frac{1}{2}, \text{ etc.}\end{aligned}$$

**Ex. II. Functions of  $225^\circ$ .**

Taking  $r=10$  gives  $x=y=-\sqrt{50}=-5\sqrt{2}$ . (Draw the figure.)

$$\begin{aligned}\therefore \sin 225^\circ &= \frac{-5\sqrt{2}}{10} = -\frac{\sqrt{2}}{2}, \\ \cos 225^\circ &= \frac{-5\sqrt{2}}{10} = -\frac{\sqrt{2}}{2}, \text{ etc.}\end{aligned}$$

**§ 257. Quadrantal Angles.** The functions of  $0^\circ$ ,  $90^\circ$ ,  $180^\circ$ , etc., can be read off directly from a figure. This should be done often, until their values are fixed in mind.

**Ex. I. Functions of  $270^\circ$ , or  $\frac{3}{2}\pi$  radians.**

Taking  $r=10$  gives  $x=0$ ,  $y=-10$ . Hence

$$\begin{aligned}\sin 270^\circ &= y/r = -1, & \csc 270^\circ &= r/y = -1, \\ \cos 270^\circ &= x/r = 0, & \sec 270^\circ &= \dots, \\ \tan 270^\circ &= \dots, & \text{ctn } 270^\circ &= x/y = 0.\end{aligned}$$

The tangent and secant do not exist for  $270^\circ$ ; for it is impossible to divide by  $x$  when  $x=0$ . They exist, however, for angles as near  $270^\circ$  as we please. (See § 258.)

## EXERCISES

1. Without tables find the sine and cosine of  $90^\circ$  and  $180^\circ$ , noting the sign in each case.

2. By measurement or inspection find the sine and cosine of  $0^\circ$ ,  $30^\circ$ ,  $60^\circ$ ,  $90^\circ$ , and other such angles in other quadrants. Plot a graph of  $\sin \theta$  and  $\cos \theta$  from  $\theta = 0^\circ$  to  $360^\circ$ .

3. Find the exact values of all the functions of  $90^\circ$  and  $360^\circ$  which exist.

4. Find the exact values of the functions of :

(a)  $225^\circ$ ,                      (b)  $330^\circ$ ,                      (c)  $315^\circ$ ,                      (d)  $150^\circ$ .

5. What can you say about the value of  $\tan \theta$  when  $\theta$  is just a little less than  $90^\circ$ ? A little more than  $90^\circ$ ?

6. What are all the angles less than  $360^\circ$  for which  $\sin \theta = 0$ ?  $\cos \theta = -1$ ?  $\tan \theta = -1$ ?

7. The same as Ex. 6, if  $\cot \theta = 0$ ;  $\sec \theta = 1$ ;  $\csc \theta = -1$ .

8. Express in radians all angles less than  $2\pi$  for which  $\cos \theta = 0$ ;  $\cot \theta = 1$ ;  $\csc \theta = 1$ .

§ 258. **Graphs.** Let us now see how the functions vary as the angle  $\theta$  increases from  $0^\circ$  to  $360^\circ$  and beyond.

If we keep  $r$  fixed, we need only consider what happens to  $x$  and  $y$ . With  $r$  fixed, the point  $P$  (Fig. 119, p. 351) moves in a circle. Hence  $y$  starts from zero, increases to  $+r$ , decreases to  $-r$  and increases again. Thus  $\sin \theta (= y/r)$  takes the values :

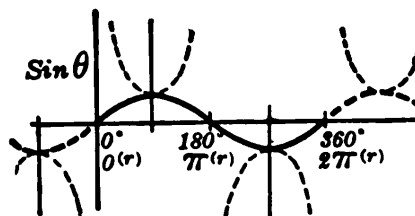

FIG. 122.

$\theta$	0	90	180	270	360
$\sin \theta$	0	1	0	-1	0

The graph is the wavy curve in Fig. 122, reaching a maximum height of 1 unit at  $90^\circ$  and a minimum of  $-1$  at  $270^\circ$ . (Note the radian equivalents.)

Similarly the graph of  $\cos \theta (= x/r)$  is seen to run as in Fig. 123.

The graph of  $\tan \theta (= y/x)$  is less simple. As  $\theta$  approaches  $90^\circ$ ,  $y$  becomes nearly equal to  $r$ . Dividing by  $x$ , which is

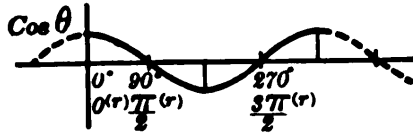

FIG. 123.

almost zero, makes  $\tan \theta$  exceedingly large. As soon as  $\theta$  passes  $90^\circ$ , there is a startling change:  $\tan \theta$  jumps to an exceedingly large negative value, — for  $x$  is now negative.

The graph has, therefore, a tremendous break. It approaches asymptotically the vertical line drawn at  $\theta = 90^\circ$ . Similarly at  $\theta = 270^\circ$ .\* (Fig. 124.)

The graphs of the cotangent, secant, and cosecant can be drawn by inspection of the foregoing graphs. That of  $\csc \theta$  is shown dotted in Fig. 122.

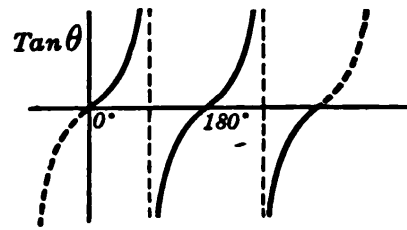

FIG. 124.

The sine, cosine, and tangent curves are extremely important. They should be thoroughly fixed in mind, — together with the radian equivalents of the angles.

### § 259. Some Important Observations.

(I) *Limitations on size.* Since  $\sin \theta$  and  $\cos \theta$  are restricted to values numerically less than 1, their reciprocals  $\csc \theta$  and  $\sec \theta$  are always numerically greater than 1. There is, however, no limitation upon  $\tan \theta$  and  $\cot \theta$ . These may have any value whatever, positive or negative.

(II) *Periodicity.* Adding  $360^\circ$  to  $\theta$  leaves the values of  $x$ ,  $y$ ,  $r$  unchanged, and hence also the values of the functions. Thus all the graphs repeat themselves every  $360^\circ$  or  $2\pi$ . In fact, the graphs of  $\tan \theta$  and  $\cot \theta$  repeat every  $180^\circ$  or  $\pi$ . For changing  $\theta$  by  $180^\circ$  affects  $x$  and  $y$  only by changing their signs, and does not affect  $y/x$ .

\* It is customary to say that the tangent of  $90^\circ$  is *infinite*, written  $\tan 90^\circ = \infty$ . But this is intended merely as a short way of stating that while  $\tan 90^\circ$  does not exist,  $\tan \theta$  increases without limit as  $\theta \rightarrow 90^\circ$ . Similarly for  $270^\circ$ . (Cf. Appendix, p. 493.)



(III) *Relation of the sine and cosine curves.* Rotating the line  $OP$  (Fig. 119, p. 351) through  $90^\circ$  would replace  $x$  by  $y$  and  $y$  by  $-x$ . (§ 209.) That is,

$$\begin{aligned} x \text{ for } \angle \theta &= y \text{ for } \angle (\theta + 90^\circ) \\ x/r \text{ for } \angle \theta &= y/r \text{ for } \angle (\theta + 90^\circ) \\ \therefore \cos \theta &= \sin (\theta + 90^\circ). \end{aligned} \quad (8)$$

Hence the graph of  $\cos \theta$  is the same as that of  $\sin (\theta + 90^\circ)$ , — *i.e.*, the same as the graph of  $\sin \theta$ , but moved  $90^\circ$  to the left.

§ 260. **Reducing to Acute Angles.** Trigonometric tables run only to  $90^\circ$ ; but they can be used to find the functions of any angle whatever.

For instance, as is clear from Fig. 125,  $\cos 160^\circ$  is numerically equal to  $\cos 20^\circ$ , since  $160^\circ$  is just as far from  $180^\circ$  as  $20^\circ$  is from  $0^\circ$ . Similarly for  $\cos 200^\circ$ , — and for  $\cos 340^\circ$ , with respect to  $360^\circ$ . Hence  $\cos 160^\circ$ ,  $\cos 200^\circ$ , and  $\cos 340^\circ$  can all be found by looking up  $\cos 20^\circ$ , and prefixing the proper sign,  $+$  or  $-$ .

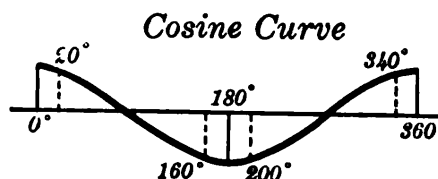

FIG. 125.

In general, to find any function of any large angle,\* we have simply to take *the difference between the given angle and  $180^\circ$  or  $360^\circ$* , whichever gives an acute angle, *look up the required function and prefix the  $+$  or  $-$  sign*, according to the quadrant. No rule is necessary as to signs. Simply visualize the angle and note whether  $x$  and  $y$  are positive or negative.

This method is easily seen to be correct by examining the graphs of  $\sin \theta$ ,  $\cos \theta$ ,  $\tan \theta$ , etc. Or it can be proved in detail by geometry, using the definitions in §§ 253–4.

Ex. I. Find  $\sin 190^\circ$ .

This angle differs from  $180^\circ$  by  $10^\circ$ . By tables,

$$\sin 10^\circ = .17365.$$

\* Of course, an angle larger than  $360^\circ$  is first reduced by a multiple of  $360^\circ$ , — or a negative angle is similarly raised, — until between  $0^\circ$  and  $360^\circ$ .

But for  $190^\circ$ ,  $y/r$  is negative. Hence,

$$\sin 190^\circ = -.17365.$$

Ex. II. Find  $\text{ctn } 275^\circ$ .

This angle differs from  $360^\circ$  by  $85^\circ$ . By tables,

$$\text{ctn } 85^\circ = .08749.$$

But for  $275^\circ$ ,  $x/y$  is negative. Hence,

$$\text{ctn } 275^\circ = -.08749.$$

**§ 261. The Reverse Operation.** To find an angle of any size when given one of its functions, we have simply to look up the acute angle which has the same function numerically; and combine this acute angle with  $180^\circ$  or  $360^\circ$ , according to the given sign.

Ex. I.  $\sin \theta = -.17365$ : find  $\theta$ .

By tables:  $.17365 = \sin 10^\circ$ .

Now  $\sin \theta$  is negative when  $y$  is. Hence we must combine  $10^\circ$  with  $180^\circ$  or  $360^\circ$  in such a way as to get an angle  $\theta$  in Quadrant III or IV:

$$\therefore \theta = 180^\circ + 10^\circ = 190^\circ, \quad \text{or } \theta = 360^\circ - 10^\circ = 350^\circ.$$

Ex. II.  $\tan \theta = -5.6713$ . ( $=y/x$ )

By tables:  $5.6713 = \tan 80^\circ$ .

Since  $\tan \theta$  is negative when  $x$  and  $y$  have opposite signs, we combine  $80^\circ$  with  $180^\circ$  or  $360^\circ$  so as to get into Quadrants II and IV:

$$\theta = 180^\circ - 80^\circ = 100^\circ, \quad \text{or } \theta = 360^\circ - 80^\circ = 280^\circ.$$

Ex. III.  $\sec \theta = -1.30541$ . ( $=r/x$ )

The reciprocal is  $\cos \theta = -.76604$ ; and  $\theta$  must be in Quadrant II or III, where  $x$  is negative.

By tables:  $.76604 = \cos 40^\circ$ .

$$\therefore \theta = 180^\circ - 40^\circ = 140^\circ, \quad \text{or } \theta = 180^\circ + 40^\circ = 220^\circ.$$

### EXERCISES

1. Find from tables the sine, cosine, and tangent of  $216^\circ$ ;  $304^\circ$ ;  $92^\circ$ .
2. The same as Ex. 1 for  $158^\circ 12'$ , and for  $260^\circ 15'.4$ .
3. How would you look up the cotangent and the secant of  $340^\circ$ ?
4. Find both values of  $\theta < 360^\circ$  for which  $\sin \theta = -.38725$ .

5. The same as Ex. 4 if  $\cos \theta = .25601$ ; also if  $\tan \theta = -3.4874$ .
6. Find all the angles  $< 360^\circ$  for which (a)  $\sin A = .88712$ ; (b)  $\cos B = -.42893$ ; (c)  $\text{ctn } C = 2.8375$ .
7. Find the sine, cosine, and tangent of  $1.5^{\text{r}}$ . (See table, p. 504.)
8. The same as Ex. 7 for  $4.137^{\text{r}}$ . (Change to degrees.)
9. Find in radians both angles  $< 2\pi^{\text{r}}$  for which (a)  $\sin A = -.67880$ ; (b)  $\cos B = .71995$ ; (c)  $\tan C = -.06301$ .
10. (a) By inspection of the graph of  $\cos \theta$ , draw a rough graph for  $\sec \theta$ . (b) The same for  $\sin \theta$  and  $\csc \theta$ . (c) The same for  $\tan \theta$  and  $\text{ctn } \theta$ .
11. According to the graphs in Figs. 122–4 what are the angles  $< 2\pi^{\text{r}}$ , for which  $\sin \theta = 0$ ?  $\cos \theta = 0$ ?  $\tan \theta = 1$ ?
12. How often does the sine curve repeat? The tangent curve?

§ 262. **Oscillating Physical Quantities.** Many physical quantities vary periodically, in much the same way as the sine of an angle.

*E.g.*, an alternating electric current rises to a maximum intensity in one direction, sinks to zero and on down to a minimum (*i.e.*, a maximum in the opposite or negative direction), rises again, etc. The varying intensity is represented by some such formula as

$$i = 10 \sin (200 t), \quad (9)$$

where  $t$  is the number of seconds elapsed, and  $200 t$  is the number of radians in the "phase angle." \*

The graph, on some scale, is the sine curve. (Fig. 122, p. 355.) The greatest value of a sine being 1, the maximum  $i$  in (9) is 10 units, represented by the greatest height of the sine curve.

Of course, the oscillations occur very rapidly. Thus in (9)  $i$  completes an oscillation when the angle  $200 t$  reaches the value  $2\pi$ :

$$200 t = 2\pi, \quad t = .01 \pi = .0314 +.$$

\* That the formula involves a trigonometric function is not strange — inasmuch as the current is generated by *circular revolutions* of an "armature."

That is, a complete oscillation takes about  $\frac{1}{30}$  sec., or the current alternates about 60 times a second. The base of each arch of the sine curve here represents .0157 sec. of time.

The rate at which  $i$  is increasing at any instant can be found approximately from the graph. To find it exactly we must be able to differentiate a sine function. (§ 263.)

### EXERCISES

*The angles here are in radians.*

1. At what values of  $t$  is the graph of  $y = 30 \sin 100 t$  just starting up from  $y = 0$ ? Down from  $y = 0$ ? Draw the graph roughly by inspection.

2. The same as Ex. 1 for each of the following:

(a)  $y = .25 \sin 4 t$ ,      (b)  $y = 20 \cos 10 t$ ,      (c)  $y = 5 \cos \pi t$ .

3. As a tuning fork vibrated, its displacement ( $x$  cm.) from the position of rest varied thus with the time ( $t$  sec.):  $x = .06 \sin 800 t$ . Draw the graph by inspection, showing the maximum displacement and the time elapsed during a vibration.

4. The same as Ex. 3 for an oscillating mechanism whose displacement ( $y$  in.) varies thus:  $y = 10 \cos 20 t$ .

5. The same as Ex. 3 for a pendulum whose angular displacement varies thus:  $\theta = .1 \sin 2 \pi t$ .

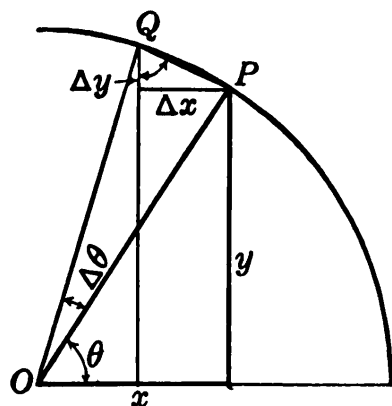

FIG. 126.

§ 263. Derivatives of  $\sin \theta$  and  $\cos \theta$ : Radian Measure. To differentiate  $\sin \theta$  by the original process (§ 53), we first let  $\theta$  increase by  $\Delta \theta$  and see how much the sine increases.

By definition,

$$\sin \theta = \frac{y}{r},$$

in which  $y$  and  $r$  may be taken for *any* point on the terminal line of  $\theta$ . But by choosing that point  $P$  whose  $r = 1$ , we have simply

$$\sin \theta = y, \quad (10)$$

and the change in  $\sin \theta$  due to any change in  $\theta$  is simply  $\Delta y$ .

But when we increase  $\theta$ , keeping  $r=1$ ,  $P$  must travel in a circle, and  $\Delta y$  is easily calculated from the small right triangle in Fig. 126.  $\angle Q = \theta + \frac{1}{2} \Delta\theta$ , these angles having sides which are mutually perpendicular.

$$\therefore \Delta y = \text{chord } PQ \cdot \cos Q = \text{chord } PQ \cdot \cos \left(\theta + \frac{1}{2} \Delta\theta\right).$$

If  $\Delta\theta$  is in radians, arc  $PQ' = r\Delta\theta$  (§ 251),  $= \Delta\theta$  simply.

$$\therefore \frac{\Delta y}{\Delta\theta} = \frac{\text{chord } PQ}{\text{arc } PQ} \cdot \cos \left(\theta + \frac{1}{2} \Delta\theta\right). \quad (11)$$

Now as  $\Delta\theta \rightarrow 0$ , the ratio of the chord to the arc approaches 1.

$$\therefore \frac{dy}{d\theta} = \cos \theta, \quad \text{or} \quad \frac{d}{d\theta}(\sin \theta) = \cos \theta. \quad (12)$$

*I.e.*, the derivative of  $\sin \theta$  is  $\cos \theta$ , if the angle is in radians.

In like manner, noting that  $x = \cos \theta$  in Fig. 126, and that the change in  $\cos \theta$  due to  $\Delta\theta$  is simply  $\Delta x$ , a negative quantity, we find

$$\begin{aligned} \frac{\Delta x}{\Delta\theta} &= -\frac{\text{chord } PQ}{\text{arc } PQ} \cdot \sin \left(\theta + \frac{1}{2} \Delta\theta\right). \\ \therefore \frac{dx}{d\theta} &= -\sin \theta, \quad \text{or} \quad \frac{d}{d\theta}(\cos \theta) = -\sin \theta. \end{aligned} \quad (13)$$

Physically, formulas (12) and (13) mean that the rates at which  $\sin \theta$  and  $\cos \theta$  change, per radian increase in  $\theta$ , are constantly equal to  $\cos \theta$  and  $-\sin \theta$ , respectively.

Ex. I. Find the rate of change of  $\sin \theta$ , per radian, at  $\theta = .5^{\circ}$ .

Answer:  $\frac{d}{d\theta}(\sin \theta) = \cos .5 = .87758.$

*Check.* By tables,  $\sin .49 = .47063$ ,  $\sin .51 = .48818$ . Thus  $\sin \theta$  increases by .01755 while  $\theta$  increases by  $.02^{\circ}$ , — or at an average rate of .8775 per radian for this interval.

§ 264. **Modification for Degree Measure.** If  $\theta$  is in degrees instead of radians, then in Fig. 126, arc  $PQ = .017453 \Delta\theta$ . (§ 251.) Hence dividing  $\Delta y$  by  $\Delta\theta$  (= arc  $PQ/.017453$ ) gives instead of (11):

$$\frac{\Delta y}{\Delta\theta} = \frac{\text{chord } PQ}{\frac{\text{arc } PQ}{.017453}} \cos\left(\theta + \frac{1}{2} \Delta\theta\right). \quad (14)$$

$$\therefore \frac{dy}{d\theta} = .017453 \cos \theta. \quad (15)$$

Likewise 
$$\frac{dx}{d\theta} = -.017453 \sin \theta. \quad (16)$$

That is, the rate of change of  $\sin \theta$  and  $\cos \theta$ , per *degree* change in  $\theta$ , is only a small fraction (.017453 . . .) of the rate of change per *radian*, — which is evidently reasonable.

The great simplicity of (12) and (13) as compared with (15) and (16) is the reason for using radian measure in practically all problems requiring the differentiation of a sine or cosine.

§ 265. **Sin  $u$  and cos  $u$ .** If  $u$  is any function of  $\theta$ , and

$$y = \sin u$$

then, by (21), p. 110,

$$\frac{dy}{d\theta} = \frac{dy}{du} \cdot \frac{du}{d\theta}, \quad (17)$$

or 
$$\frac{dy}{d\theta} = \cos u \cdot \frac{du}{d\theta}. \quad (18)$$

In words: the derivative of the sine of any angle equals the cosine of that same angle times the derivative of the angle, — expressed in radians.

Similarly for the derivative of a cosine.

Ex. I. Differentiate  $i = \cos(100t)$ .

Answer: 
$$\frac{di}{dt} = -\sin(100t) \frac{d}{dt}(100t) = -100 \sin(100t). \quad (19)$$

## EXERCISES

1. Find the instantaneous rate of increase of  $\sin \theta$ , per radian, at  $\theta = .6$ <sup>(r)</sup>. Check by finding from tables the average rate from  $\theta = .59$ <sup>(r)</sup> to  $.61$ <sup>(r)</sup>.

2. The same as Ex. 1 for  $\cos \theta$ .

3. Find the instantaneous rate of increase of  $\sin \theta$ , per degree, at  $\theta = 60^\circ$ . Check by comparing the actual increase from  $59^\circ 30'$  to  $60^\circ 30'$ .

4. The same as Ex. 3 for  $\cos \theta$ .

5. Differentiate the following, the angles being in radians:

(a)  $y = 75 \sin 10 t$ ,

(b)  $r = .6 \cos 8 t$ ,

(c)  $z = .12 \sin (2 t + 5)$ ,

(d)  $x = 20 \cos (t - .3)$ ,

(e)  $s = 40 \sin \left( \frac{\pi}{4} t \right)$ ,

(f)  $l = .07 \cos (t^3)$ .

6. Differentiate the following, the angles being in degrees:

(a)  $y = 100 \sin (3 t + 20)$ ,

(b)  $x = 3 \cos (.02 t - 5)$ .

7. The centrifugal acceleration of points on the earth's surface, due to the rotation, varies with the latitude thus:  $A = .1105 \cos L$ , approximately. Find the rate at which  $A$  changes with  $L$ , per degree, at  $L = 30^\circ$ .

8. The intensity of a certain alternating current varies thus:  $i = 200 \sin 500 t$ . ( $t$  is the number of seconds elapsed, and  $500 t$  the number of radians in "the phase-angle.") Find  $i$  and  $di/dt$  when  $t = .002$ .

9. In Ex. 8 plot  $i$  from  $t = 0$  to  $.01$ , and check your results graphically. (In plotting take  $t = 0, .002, .004, \dots$ , besides noting maxima, etc.)

10. In Ex. 3, p. 360, find the displacement and speed of the fork at  $t = .002$ .

11. The same as Ex. 10 for the mechanism in Ex. 4, p. 360.

12. The same for the pendulum in Ex. 5, p. 360.

**§ 266. Notation for an Angle.** The symbol  $\sin^{-1}$  is commonly used to denote an *angle whose sine is . . .* (whatever number follows).

Thus  $\sin^{-1}.5$  denotes an angle whose sine is  $.5$ . This angle might be  $30^\circ$ , or  $150^\circ$ , or  $390^\circ$ , etc.

Likewise  $\theta = \tan^{-1} 2.88$  means simply that  $\theta$  is an angle whose tangent is  $2.88$ , or  $\tan \theta = 2.88$ .

Observe that the  $-1$  is not an exponent but simply a part of the new symbol for an angle. It does, however, have a significance somewhat analogous to that of a negative exponent, in this way: Looking up  $\theta = \sin^{-1} .5$  is the *reverse* of the operation of looking up  $\sin \theta$ ; just as multiplying by  $10^{-1}$  is the reverse of multiplying by  $10^1$ .

**§ 267. Notation for Powers.** To indicate a power of a trigonometric function, it is customary to apply the exponent directly to the function, rather than to write it after the angle. Thus

$$\begin{aligned}\sin^2 \theta &\text{ means } (\sin \theta)^2, \\ \sec^3 \theta &\text{ means } (\sec \theta)^3,\end{aligned}$$

etc., while  $\sin \theta^2$  would mean the sine of an angle whose number of units is the square of the number in  $\theta$ .

An exception occurs, however, in the case of the  $-1$  power. We cannot write  $(\sin u)^{-1}$  in the abbreviated form  $\sin^{-1} u$ , having adopted the latter symbol to denote an angle whose sine is  $u$ .\*

Ex. I. Differentiate  $y = \sin^{10} \theta$ .

Here  $y$  is not primarily a trigonometric function but rather a *power*, viz.,  $y = (\sin \theta)^{10}$ . This is of the form  $y = u^n$ .

$$\therefore \frac{dy}{d\theta} = 10(\sin \theta)^9 \cos \theta = 10 \sin^9 \theta \cos \theta.$$

[Where does the factor  $\cos \theta$  come from? If in doubt, think how you would differentiate the form  $y = (x^3 + 7)^{10}$ . Note the  $3x^2$ . (§ 77.)]

### EXERCISES

1. Look up, in radians and in degrees, the smallest positive angles denoted by:  
(a)  $\sin^{-1} .86742$ , (b)  $\cos^{-1} (-.02920)$ , (c)  $\tan^{-1}(-1)$ .
2. The area of a segment cut from a circle of radius  $r$  ft. by a chord  $x$  ft. from the center is  $A = r^2 \cos^{-1} (x/r) - x \sqrt{r^2 - x^2}$  sq. ft., the angle being in radians. Calculate this if  $r = 10$  and  $x = 6$ .
3. Calculate  $\sin^3 1.2^{(r)}$  and  $\cos^{-2} 35^\circ$ .

\* To avoid this confusion the symbol *arcsin* is often used for an angle in place of  $\sin^{-1}$ .



4. Differentiate  $y=3 \sin^4 \theta$ , and  $x=7 \cos^3 (5 t)$ , the angles being in radians.

§ 268. **Curves in Polar Coördinates.** As a point  $(r, \theta)$  moves along any curve,  $r$  varies with  $\theta$  in some definite way. That is,  $r=f(\theta)$ . Conversely, all the points whose polar coördinates satisfy a given equation lie along some definite curve.

Ex. I. Plot the curve  $r=10 \sin \theta$ . (20)

Substituting values for  $\theta$  gives the adjacent table. Plotting the positive values of  $r$ , we get the curve in Fig. 127. (Plotting the negative values of  $r$ , according to the system mentioned in Ex. 7, p. 345, would merely retrace the same curve.)

This curve is a true circle. For  $\sin \theta=y/r$ , which gives in (20):

$$r^2 = 10 y,$$

$$i.e., x^2 + y^2 = 10 y.$$

$\theta$	$r$
0	0
30	5
60	8.66
90	10
120	8.66
150	5
180	0
210	-5
—	—
—	—

### EXERCISES

1. A point moves so that  $r=.05 \theta$  always. Make a table of values of  $r$  for values of  $\theta$  at intervals of  $60^\circ$ , and draw the path from  $\theta=0$  to  $360^\circ$ .

2. What sort of a curve is  $r=\theta/3$ ?  $r=k\theta$ ? (If in doubt make a table.)

3. The same as Ex. 1 for  $r\theta=60$ ; but try also small values of  $\theta$ , say  $1^\circ$ ,  $.1^\circ$ .

4. Plot the following curves from  $\theta=0$  to  $90^\circ$ :

(a)  $r=\cos \theta$ ,

(b)  $r=\sin 2 \theta$ .

5. Draw roughly by inspection  $r=2 \theta$ , from  $\theta=0^{(r)}$  to  $\theta=2 \pi^{(r)}$ .

6. The same as Ex. 5 for  $r=e^{5\theta}$ .

7. In Ex. 6 find the rate of change of  $r$ , at  $\theta=.8^{(r)}$ .

8. For each curve in Ex. 4 find the rate of change of  $r$ , per degree, at  $\theta=20^\circ$ .

9. The equation of the path of Halley's Comet is  $r=1.158/(1+.9673 \cos \theta)$ . Calculate  $r$  when  $\theta=0^\circ$  and when  $\theta=180^\circ$ . (Cf. Table 1, p. 345.)

§ 269. **Summary of Chapter X.** Polar coordinates are useful in locating points, studying motion, and defining the trigonometric functions of angles in general. In higher

courses they are used in studying curves analytically.

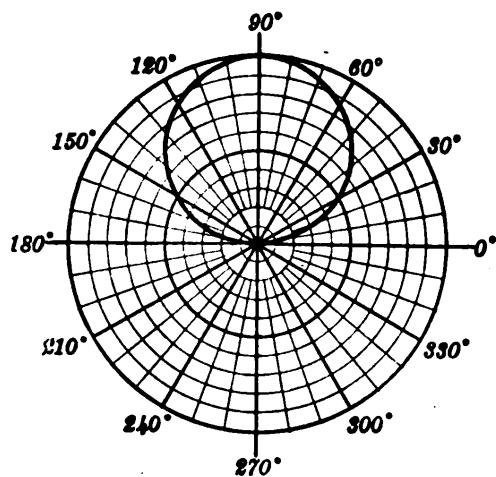

FIG. 127.

The simplest unit angle in differentiations, and in motion problems generally, is the *radian*. A circular arc equals its radius times the number of radians in its central angle. An angle may have any size whatever, positive or negative.

Very small angles are best expressed in seconds, especially in making estimates which regard an arc as equal to its chord, etc.

The graphs of the trigonometric functions are important in many scientific problems, as well as in showing how to look up any given function.

When one function of an angle is known, all the others can be calculated exactly, without tables. This shows incidentally that there must be some definite relations among the several functions. We turn now to the consideration of such relations and their uses.

### EXERCISES

1. With minor fluctuations, the pressure of steam in a boiler varied one afternoon as shown in Table I:

(I) TIME	12	1	2	3	4	5	6
<i>P</i> (LBS.)	96	105	116	77	95	120	10

Plot the polar graph, using  $15^\circ$  for 1 hour. (In the automatic recording charts the radial lines curve slightly backward, but the graph appears much as here.)

2. Table II shows several positions of the planet Mercury during one of its revolutions about the sun. Plot the path.

(II) $r$	.31	.36	.44	.47	.43	.35	.31
$\theta$	73°	158°	215°	255°	308°	360°	73°

3. Find by measurement and by trigonometry the rectangular coordinates of the points whose polar coördinates are  $(10, 70^\circ)$ ,  $(10, 155^\circ)$ , and  $(20, 200^\circ)$ .

4. *Vice versa* find the polar coördinates of the points whose rectangular coördinates are  $(5, 12)$ ,  $(-8, 15)$ ,  $(20, -15)$ .

5. Write formulas for the rectangular coördinates  $(x, y)$  of any point whose polar coördinates are  $(r, \theta)$ ; and *vice versa*.

6. When an object travels in a circle of radius  $r$  ft. with an angular speed of  $\omega$  rad./sec., its centrifugal acceleration is  $A = \omega^2 r$  (ft./sec<sup>2</sup>). Find  $A$  for points on the earth's equator, taking  $r = 3960$  (mi.). Also show that for points in any latitude  $L$ :  $A = .1105 \cos L$ , approx. [Cf. Ex. 7, p. 363.]

7. What are the values, in degrees  $< 360$ , and in radians  $< 2\pi$ , of (a)  $\sin^{-1} 0$ , (b)  $\cos^{-1} 0$ , (c)  $\tan^{-1} (-1)$ , (d)  $\text{ctn}^{-1} 0$ ?

8. Given  $\text{ctn } A = -4/3$ , find without tables the other five functions for both possible angles  $< 360^\circ$ .

9. Find the diameter of a sun spot in the center of the disc if it subtends at the earth, when 91,000,000 mi. away, an angle of  $8''$ .

10. A point moved in a circle of radius 5 in. so that after  $t$  min.  $\theta = 60t^2 - t^3$  (radians). Find its maximum speed; also its tangential acceleration when  $t = 10$ .

[11.] Divide both members of the equation  $x^2 + y^2 = r^2$  by  $r^2$ , and express the resulting equation in terms of trigonometric functions. The same, dividing by  $x^2$ ; by  $y^2$ .

12. Find the slope and flexion of the sine curve  $y = \sin \theta$  at  $\theta = .4^{(r)}$ .

13. Show without plotting that the curves  $r = 10 e^\theta$  and  $r = 5 \log \theta$  are spirals of some kind. In each find how fast  $r$  increases, per radian, at  $\theta = 2$ .

14. Solve Kepler's equation  $\theta - e \sin \theta = M$  for  $\theta$  when  $e = .3$  and  $M = .75$ . (See § 241.)

## CHAPTER XI

### TRIGONOMETRIC ANALYSIS

#### FUNDAMENTAL RELATIONS AMONG THE FUNCTIONS

§ 270. **The Basic Identities.** The coördinates  $x$ ,  $y$ , and  $r$ , used in defining the trigonometric functions (§ 253), always have this relation :

$$x^2 + y^2 = r^2. \quad (1)$$

Dividing by  $r^2$  gives  $(x/r)^2 + (y/r)^2 = 1$ . That is,

$$(\cos \theta)^2 + (\sin \theta)^2 = 1,$$

or rearranging and using the notation of § 267 :

$$\sin^2 \theta + \cos^2 \theta = 1. \quad (2)$$

Equation (2) is true for every angle large or small: for  $300^\circ$  or for  $.02''$ . For this reason  $\sin^2 \theta + \cos^2 \theta$  is said to be *identically* equal to 1, and equation (2) is called an *Identity*.

Other identities result from dividing (1) by  $x^2$  or  $y^2$ ; viz.,

$$1 + \tan^2 \theta = \sec^2 \theta, \quad (3)$$

$$1 + \text{ctn}^2 \theta = \text{csc}^2 \theta. \quad (4)$$

Still others come from  $\tan \theta = y/x$  and  $\text{ctn} \theta = x/y$ , by dividing numerator and denominator by  $r$ :

$$\tan \theta = \frac{y/r}{x/r} = \frac{\sin \theta}{\cos \theta}, \quad (5)$$

$$\text{ctn} \theta = \frac{x/r}{y/r} = \frac{\cos \theta}{\sin \theta}. \quad (6)$$

These identities (2)–(6) and the reciprocal relations

$$\operatorname{ctn} \theta = \frac{1}{\tan \theta}, \quad \sec \theta = \frac{1}{\cos \theta}, \quad \operatorname{csc} \theta = \frac{1}{\sin \theta}, \quad (7)$$

will be used frequently, and should be memorized very carefully.

Doing this thoroughly now will save much time and trouble. Practice writing the list (2)–(7) from memory. Then, if you get any wrong, study those especially. Notice the similarity of (3) and (4), and of (5) and (6); also that (3) involves no co-functions, and (4) only co-functions.

**§ 271. Some Applications.** The foregoing identities are useful in solving equations, and in simplifying complicated expressions before differentiating or integrating.

**Ex. I.** The angle at which a certain gun should be elevated to shoot a certain distance is to be found from the equation

$$\sin \theta \cos \theta = .25. \quad (8)$$

This involves *two* unknown quantities,  $\sin \theta$  and  $\cos \theta$ . But always

$$\sin^2 \theta + \cos^2 \theta = 1 : \quad (9)$$

and, by combining these two equations, we can solve for  $\sin \theta$  or  $\cos \theta$ . The simplest way is to add twice (8) to (9), to get a perfect square, viz.,  $(\sin \theta + \cos \theta)^2 = 1.5$ , — or similarly to subtract twice (8). Thus

$$\begin{aligned} \sin \theta + \cos \theta &= \sqrt{1.5} = 1.2247, & (10) \\ \sin \theta - \cos \theta &= \pm \sqrt{.5} = \pm .7071. \end{aligned}$$

Adding these gives  $\sin \theta = .9659$  or  $.2588$ . Subtracting gives  $\cos \theta = .2588$  or  $.9659$ . There are two angles,  $\theta = 75^\circ$  or  $15^\circ$ .

How is this possible physically? Also why could we not take  $\sin \theta + \cos \theta = -\sqrt{1.5}$  in (10)?

Ex. II. Simplify and differentiate  $y = (\csc \theta - \sin \theta) / \operatorname{ctn} \theta$ .  
By (6), (7):

$$y = \frac{\frac{1}{\sin \theta} - \sin \theta}{\frac{\cos \theta}{\sin \theta}}, = \frac{1 - \sin^2 \theta}{\cos \theta}.$$

By (2) this reduces to  $y = \cos^2 \theta / \cos \theta = \cos \theta$ .

$$\therefore \frac{dy}{d\theta} = -\sin \theta.$$

*N.B.* It is usually best to express all the given functions in terms of the *sine* and *cosine*, as this can always be done without radicals. But it may be better to put  $\operatorname{ctn} \theta = 1/\tan \theta$ , if only these two functions appear; or to use (3) when only even powers of  $\tan \theta$  and  $\sec \theta$  appear; etc.

§ 272. **Trigonometric Equations.** In solving a trigonometric equation there are usually three steps: (a) Expressing all the given functions in terms of a single function; (b) solving algebraically for the value of that function; and (c) finding all possible angles.

Ex. I. Solve  $5 \sin \theta - 10 \cos \theta + 11 = 0$ . (11)

Replacing  $\cos \theta$  by  $\pm \sqrt{1 - \sin^2 \theta}$ , transposing and squaring gives:

$$125 \sin^2 \theta + 110 \sin \theta + 21 = 0.$$

This is a quadratic equation for  $\sin \theta$ . By formula (2), p. 326,

$$\sin \theta = \frac{-110 \pm \sqrt{110^2 - 4(125)(21)}}{250} = -\frac{7}{25}, -\frac{3}{5}$$

$$\theta = \sin^{-1}\left(-\frac{7}{25}\right), \text{ or } \sin^{-1}\left(-\frac{3}{5}\right)$$

Substituting these values of  $\sin \theta$  in (11) gives  $\cos \theta = \frac{24}{25}$  or  $\frac{4}{5}$ . Since  $\theta$  has a negative sine and positive cosine, it lies in the fourth quadrant; and is found by subtracting from  $360^\circ$  (or  $2\pi$ ) the acute angle whose sine is  $\frac{7}{25}$  or  $\frac{3}{5}$ .

Ex. II. For a projectile fired with a speed of 4000 ft./sec., and at any inclination  $\theta$ , the path is

$$y = x \tan \theta - \frac{x^2}{1,000,000 \cos^2 \theta}.$$

For what  $\theta$  will this strike a balloon at (20000, 8000)? We must have  $y=8000$  when  $x=20000$ .

$$\therefore 8000 = 20000 \tan \theta - \frac{400}{\cos^2 \theta}.$$

The easiest way to solve this equation is to observe that

$$\frac{1}{\cos^2 \theta} = \sec^2 \theta = 1 + \tan^2 \theta.$$

$$\therefore 8000 = 20000 \tan \theta - 400 (1 + \tan^2 \theta)$$

or

$$\tan^2 \theta - 50 \tan \theta + 21 = 0,$$

$$\therefore \tan \theta = \frac{50 \pm \sqrt{50^2 - 84}}{2} = 49.58, \text{ or } .42$$

$$\therefore \theta = 88^\circ 51', \text{ or } 22^\circ 47'.$$

### EXERCISES

1. Look up the sine, cosine, and tangent of  $40^\circ$ ; and verify formulas (2) and (5) arithmetically for this angle.

2. Express each of the following in terms of  $\sin \theta$  and  $\cos \theta$  and simplify. Then find the derivative of each (in radian measure).

(a)  $\cos \theta \tan \theta,$

(b)  $\cot \theta / \csc \theta,$

(c)  $\csc \theta - \cot \theta \cos \theta,$

(d)  $\sec \theta - \tan \theta \sin \theta,$

(e)  $\frac{\sec^2 \theta - \tan^2 \theta}{\csc \theta},$

(f)  $\frac{\csc^2 \theta - \cot^2 \theta}{\sec \theta},$

(g)  $\frac{\sin \theta}{1 - \cot \theta} + \frac{\cos \theta}{1 - \tan \theta},$

(h)  $\cos \theta \sqrt{\sec^2 \theta - 1}, \quad [\theta < 90^\circ].*$

3. Establish each of the following identities by reducing the left member to the form on the right side:

(a)  $\frac{\cos^2 \theta - \sin^2 \theta}{\cot \theta - \tan \theta} = \sin \theta \cos \theta,$

(b)  $\frac{\sin \theta}{1 + \cos \theta} + \frac{1 + \cos \theta}{\sin \theta} = 2 \csc \theta,$

(c)  $\frac{\tan \theta \sin \theta}{\tan \theta + \sin \theta} = \frac{\tan \theta - \sin \theta}{\tan \theta \sin \theta},$

(d)  $\frac{\tan \theta \csc \theta - \cot \theta \sec \theta}{\sin \theta - \cos \theta} = \sec \theta \csc \theta,$

(e)  $\sqrt{\frac{1 - \cos \theta}{1 + \cos \theta}} = \csc \theta - \cot \theta, \quad \theta < 90^\circ.$

(Hint: Multiply above and below by  $1 - \cos \theta$ .)

\* This fact is given to determine the *sign* of the function which will replace the given positive radical in simplifying.

4. Reduce to simpler forms:

$$(a) \sin^3 \theta \cos \theta + \cos^3 \theta \sin \theta, \quad (b) \sqrt{\frac{1+\sin \theta}{1-\sin \theta}}, \quad \theta < 90^\circ,$$

$$(c) \tan \theta + \frac{\cos \theta}{1+\sin \theta}, \quad (d) \frac{\tan^2 \theta}{\sec \theta - 1}.$$

(e) In Ex. 2 (e), (f), (h), simplify in part without changing to  $\sin \theta$  and  $\cos \theta$ .

(f) Simplify and differentiate:  $y = (\sqrt{1+\sin \theta} + \sqrt{1-\sin \theta})^2$ .

5. Simplify and integrate each of the following expressions:

$$(a) (\tan \theta + \operatorname{ctn} \theta) \sin \theta \cos \theta,$$

$$(b) (1 + \operatorname{ctn} \theta - \operatorname{csc} \theta) (1 + \tan \theta + \sec \theta).$$

6. (a) Differentiate  $y = \tan \theta$ . [Use (5), p. 368, and § 184.]

(b) In similar fashion differentiate  $y = \operatorname{csc} \theta$ .

7. Solve for some function of  $\theta$ , and look up each possible angle  $< 360^\circ$ :

$$(a) 5 \operatorname{ctn} \theta = 3 \operatorname{csc} \theta, \quad (b) \tan \theta + 3 \operatorname{ctn} \theta = 4, \quad (c) \sin \theta \cos \theta = .15.$$

8. The same as Ex. 7 for each angle, in radians,  $< 2\pi$ , if:

$$(a) 5 \sec^2 \theta - 8 \tan^2 \theta = 4, \quad (b) 2 \sin^2 \theta + 3 \cos \theta = 0.$$

9. For a projectile fired with a certain speed the range is  $R = 100000 \sin \theta \cos \theta$ . For what  $\theta$  will  $R = 4800$ ?

10. In Ex. 9 find the maximum value of  $R$  as  $\theta$  varies.

11. When a block of weight  $W$  lb. rests on a plane of inclination  $\theta$ , and with a "coefficient of friction"  $f$ , the pull up the plane necessary to prevent sliding is  $P = W (\sin \theta - f \cos \theta)$ . If  $f = .15$ , what  $\theta$  will just make  $P = 0$ ?

12. Find for what inclination of a line of fixed length the sum of the horizontal and vertical projections will be greatest.

13. Two tangents to a circle are 20 in. long. The chord joining their points of tangency is 4 in. from the center. Find the angle between the tangents.

14. If the path of a projectile is  $y = x \tan \theta - x^2/250000 \cos^2 \theta$ , for what (smaller) value of  $\theta$  will it strike the point (50000, 1875)?

**§ 273. Further Derivatives.** Differentiation formulas for the tangent, cotangent, etc., can be obtained by expressing these functions in terms of the sine and cosine, and using the fraction formula (§ 184).



$$\text{Ex. I.} \quad \text{ctn } \theta = \frac{\cos \theta}{\sin \theta}.$$

$$\begin{aligned} \therefore \frac{d}{d\theta}(\text{ctn } \theta) &= \frac{\sin \theta \frac{d}{d\theta}(\cos \theta) - \cos \theta \frac{d}{d\theta}(\sin \theta)}{\sin^2 \theta} \\ &= -\frac{\sin^2 \theta + \cos^2 \theta}{\sin^2 \theta} = -\frac{1}{\sin^2 \theta} = -\text{csc}^2 \theta. \end{aligned}$$

$$\text{Ex. II.} \quad \sec \theta = \frac{1}{\cos \theta}.$$

$$\begin{aligned} \therefore \frac{d}{d\theta}(\sec \theta) &= -1 (\cos \theta)^{-2} \cdot \frac{d}{d\theta}(\cos \theta) \\ &= +\frac{\sin \theta}{\cos^2 \theta} = \frac{1}{\cos \theta} \cdot \frac{\sin \theta}{\cos \theta} = \sec \theta \tan \theta. \end{aligned}$$

*N.B.* For degree measure multiply by .017453 . . . ; and for derivatives with respect to  $t$ , multiply by  $d\theta/dt$ .

Tan  $\theta$  and csc  $\theta$  are differentiated similarly. All the formulas are listed in the Appendix, p. 493. They should be memorized if time permits their use at any length.

### EXERCISES

1. Using the formulas (*E*), p. 493, differentiate :

- |                                |  |
|--------------------------------|--|
| (a) $y = \tan 4t$ ,            | (b) $z = \sec 5\theta$ ,   |
| (c) $w = \text{ctn } (5t^2)$ , | (d) $u = \text{csc } (3/t)$ ,                                    |
| (e) $x = \tan^3 \theta$ ,      | (f) $v = \text{csc}^4 (\theta/2)$ ,                              |
| (g) $r = \log (\sin \theta)$ , | (h) $s = 3\theta + 3 \text{ctn } \theta - \text{ctn}^3 \theta$ , |
| (i) $x = e^{3t} \sin t$ ,      | (j) $y = e^t \sec t$ .   |

2. Differentiate, after making any helpful simplifications :

- |   |   |
|---|---|
| (a) $y = \log \sqrt{\frac{1 + \sin x}{1 - \sin x}}$ , | (b) $z = \frac{\text{ctn}^2 \theta}{\text{csc } \theta + 1}$ ,                        |
| (c) $w = \log \sqrt{\frac{\sec x + 1}{\sec x - 1}}$ , | (d) $x = \text{ctn } \theta - \sec \theta \text{csc } \theta (1 - 2 \sin^2 \theta)$ . |

3. (a)–(e). Differentiate the right members of Ex. 3 (a)–(e), p. 371.

4. When a comet moves in a parabolic orbit, the equation of its path has the form  $r = p \sec^2 (\theta/2)$ ,  $p$  being the distance of nearest ap-

proach to the sun. If  $p = .8$ , find the rate at which  $r$  is changing, per radian, when  $\theta = \pi/2$  <sup>(r)</sup>.

5. What is the slope of the tangent curve (Fig. 124, p. 356) at  $\theta = 0$  <sup>(r)</sup>? Of the curve  $y = \text{ctn } \theta$ , at  $\theta = \pi/4$  <sup>(r)</sup>?

§ 274. **Further Motion Problems.** In Chapter VIII we saw how to study the motion of a point  $(x, y)$  when its equations of motion are known, — *i.e.*, equations giving  $x$  and  $y$  in terms of  $t$ . (§§ 187–191.) Some further types of motion may now be considered, in whose equations trigonometric functions are involved.

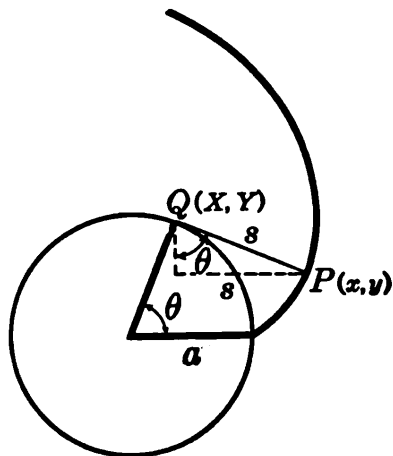

FIG. 128.

Ex. I. A taut string is unwound from a circle of radius  $a$ . Find how its free end  $P$  travels.

The sides of the right triangle in Fig. 128 are  $(x - X)$  and  $(Y - y)$ .

The hypotenuse is the length  $s$  unwound,  $= a\theta$  by § 251.

$$\therefore \frac{x - X}{a\theta} = \sin \theta, \quad \frac{Y - y}{a\theta} = \cos \theta,$$

$$\text{whence} \quad \begin{aligned} x &= X + a\theta \sin \theta, & &= a(\cos \theta + \theta \sin \theta), \\ y &= Y - a\theta \cos \theta, & &= a(\sin \theta - \theta \cos \theta). \end{aligned} \quad (12)$$

If the string is unwound at a constant angular rate of  $k$  radians per sec., then  $\theta = kt$ . Substituting this in (12) gives the equations of motion for  $P$ . (See Ex. 3–4, below.)

### EXERCISES

*N. B.* In the following problems,  $t$  denotes the number of radians in the angles concerned, and also the number of seconds of time elapsed.\*

1. A point  $(x, y)$  moves so that  $x = 40 \cos t$ ,  $y = 40 \sin t$ . Plot the path from  $t = 0$  to  $t = 6.5$ . Could you have anticipated the result by eliminating  $t$ ? Explain.

\* *Suggestion:* Keep a few of these problems to work from day to day.

2. In Ex. 1 find the speed at any time; also the distance traveled from  $t=0$  to  $t=2\pi$ . (See §§ 187–191.)

3. A point moves so that  $x=10(\cos t+t \sin t)$ ,  $y=10(\sin t-t \cos t)$ . Plot the path from  $t=0$  to  $t=8$ , taking  $t$  at intervals of 1<sup>(r)</sup>. Two figures in the value of each  $x$  or  $y$  will suffice.

4. In Ex. 3 show that the speed at any instant equals  $10t$ ; and find the length of the path plotted. [Note the products  $t \sin t$ , etc. Cf. § 182.]

5. A point moves thus:  $x=10(t-\sin t)$ ,  $y=10(1-\cos t)$ . Plot the path, taking  $t=0, 1^{(r)}, 2^{(r)},$  to  $8^{(r)}$ . Exactly when does the first arch end?

6. In Ex. 6 find the speed at any instant.

7. A point  $Q$  moves in a circle of radius 10 with an angular speed of 2 rad./sec. Meanwhile its projection  $P$  on the horizontal diameter oscillates. Derive a formula for the distance of  $P$  from the center at any time.

8. A point  $P$  moves so that  $x=10 \cos^3 t$ ;  $y=10 \sin^3 t$ . Plot the path from  $t=0$  to  $t=3.5$ , at intervals of .5. For exactly what value of  $t$  is  $y$  greatest, and when is  $y=0$  again?

9. In Ex. 8 find the speed at any time, and in particular, when  $P$  is nearest the origin. Find also the length of the path from  $t=0$  to  $t=\pi/2$ .

10. A point moves so that  $x=10 \cos t$ ;  $y=6 \sin t$ . Plot the path,  $t=0$  to  $t=\pi$ , and measure its length. What sort of curve is it?

**§ 275. Involutés.** The path of any point on a string which is being unwound from a given curve is called an *involute* of that curve.

The spiral in Ex. I, § 274, is an involute of a circle. Arcs of this involute are much used in designing gears, cams, etc., because of the excellent rolling contact obtainable with such arcs. (This is explained fully in books on machine design.)

**§ 276. The Cycloid.** When a circle rolls along a straight line without slipping, any point on it traces out some definite curve, — a series of arches. This curve is called a *cycloid*.

To study it, choose axes through  $A$  where  $P$  starts up. Then

$$x = AQ - u, \quad y = QC - v. \quad (13)$$

But  $AQ$  equals the arc  $PQ$  which rolled along it. That is,  $AQ = a\theta$ . Also  $QC = a$ ,  $u = a \sin \theta$ ,  $v = a \cos \theta$ . Hence (13) becomes

$$x = a(\theta - \sin \theta), \quad y = a(1 - \cos \theta). \quad (14)$$

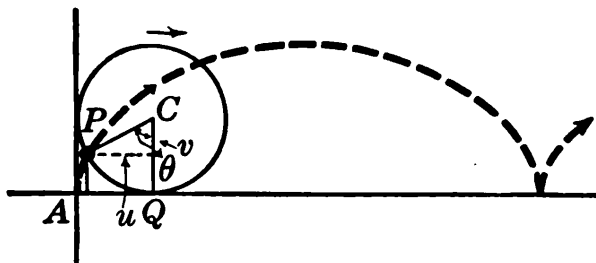

FIG. 129.

If the circle rolls at a constant angular speed,  $k$  radians per sec., then  $\theta = kt$ , and substituting this in (14), we have the equations of motion.

The cycloid has various interesting geometrical and physical properties, established in higher courses, — of which the following may be mentioned here :

(1) The length of one arch is exactly four times the diameter of the rolling circle, and the area under the arch is exactly three times that of the circle.

(2) The curve down which a particle would *slide* from one given point to another *in the shortest possible time* is a cycloid, — inverted. (3) The *time* of sliding to the lowest point is the same, no matter where the point starts on the cycloid. (4) The *involute* of a cycloid, starting to unwind at the middle of an arch, is an equal cycloid. Hence a pendulum swinging between two inverted cycloids, with its string unwinding alternately from each, travels along a cycloid. (5) The time of swing of such a “cycloidal pendulum” is strictly independent of the angle through which it swings. This is only approximately true of an ordinary pendulum.

§ 277. **Simple Harmonic Motion.** If a point  $Q$  moves in a circle with a constant speed, its projection  $P$  upon any

diameter will oscillate back and forth in a certain way. (Fig. 130.) This type of oscillating motion is called Simple Harmonic Motion, — abbreviated *S. H. M.*

To study the nature of an *S. H. M.*, we need an equation giving the distance  $x$  from the center of oscillation at any time.

Now

$$x = r \cos \theta.$$

And by hypothesis the angular speed of  $Q$  is some constant  $d\theta/dt = k$ , whence

$$\theta = kt + C,$$

$C$  being the value of  $\theta$  when we begin to count time.

$$\therefore x = r \cos (kt + C). \quad (15)$$

This is a general formula, true for any *S. H. M.*, and giving  $x$ , the “displacement” from the center, at any time.

Differentiating twice gives

$$\begin{aligned} dx/dt &= -kr \sin (kt + C), &= \text{speed of } P. \\ d^2x/dt^2 &= -k^2r \cos (kt + C), &= \text{accel. of } P. \\ \therefore d^2x/dt^2 &= -k^2x. \end{aligned} \quad (16)$$

That is, *the acceleration is constantly proportional to the displacement  $x$ , — negatively proportional, — which is the characteristic feature of every *S. H. M.**

The acceleration is zero at the center, where the speed is a maximum. It is greatest at the left extreme, when  $x = -r$ , though the speed is then passing through zero from negative to positive.

*S. H. M.*'s occur frequently in machinery. Also many motions which are not simple harmonic may be regarded as the result of combining several or many such motions. The oscillations of an alternating electric current and of waves of light and sound are of this general character.

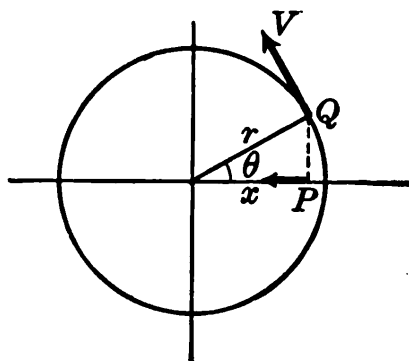

FIG. 130.

## EXERCISES

1. What are the equations of motion along a cycloid if the generating circle has a radius of 50 in. and an angular speed of .2 rad./sec.? What if  $r=12$  and  $k=.8$ ?

2. A circle of radius 20 inches rolls along a straight line with an angular speed of .3 rad./sec. Find the speed of a point of the circumference when at half its greatest height, and also when highest.

3. If  $Q$  (Fig. 130) moves with an angular speed of .4 rad./sec., and  $r=5$ , find the speed of  $P$  when passing through the center. Also find the position, speed, and acceleration of  $P$  three seconds after starting, if  $\theta=.8$  at  $t=0$ .

4. What is the equation for an *S. H. M.* if the time of a complete oscillation is 2 sec., and the maximum displacement of 15 in. occurs at  $t=0$ ? Find the speed at  $t=.4$ .

5. Like Ex. 4 if the period is  $\pi$  sec. and the maximum displacement is 20 in. occurring at  $t=\pi/6$  sec.

[6.] Which of the following is the derivative of some one of the six trigonometric functions aside from sign:  $\sin \theta$ ,  $\tan \theta$ ,  $\sec \theta$ ,  $\sin^2 \theta$ ,  $\tan^2 \theta$ ,  $\sec^2 \theta$ ?

§ 278. **Damped Oscillations.** The exponential curve (Fig. 79, p. 244) shows how a direct electric current will "die away" after the *E.M.F.* is cut off. But an *alternating* current continues to alternate while dying out, the

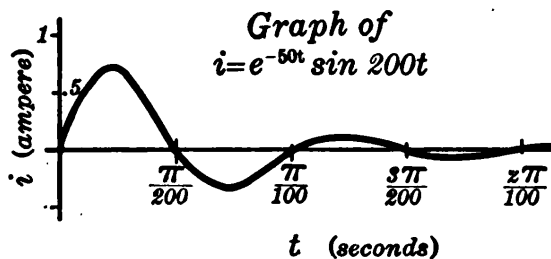

FIG. 131.

intensity at any instant being given by some such equation as

$$i = e^{-50t} \sin 200t. \quad (17)$$

The "damping factor"  $e^{-50t}$  rapidly decreases, and makes the successive waves of the graph smaller and smaller. But, by (17), the waves all come at the same intervals of time. For  $i=0$  only when  $\sin 200t=0$ , — *i.e.*, when  $200t=0, \pi, 2\pi$ , etc., or  $t=0, .0157, .0314$ , etc. (Fig. 131.)

To locate the maxima, differentiate (as in § 182):

$$di/dt = e^{-50t} \cos 200t (200) + e^{-50t} \sin 200t (-50).$$

Putting  $di/dt=0$  gives, since  $e^{-50t}$  cannot be zero,

$$200 \cos (200t) - 50 \sin (200t) = 0.$$

To solve this equation easily, divide by  $50 \cos 200t$ :

$$\tan (200t) = 4.$$

In radians, the acute angle whose tangent is 4 is 1.33.

The next, in Quadrant III, is larger by  $\pi (= 3.14)$  radians, etc.

$$\begin{aligned} \therefore 200t &= 1.33, & 4.47, \\ \therefore t &= .0066+, & .0223+. \end{aligned}$$

The first of these values makes  $i$  a maximum, the next a minimum, and so on. (Verify by testing  $di/dt$  at  $200t=0, \pi/2, \pi$ , etc.)

**§ 279. Trigonometric Integrals.\*** In practical work it is often necessary to integrate a trigonometric expression.

In some cases this is merely a matter of reversing a standard differentiation formula. Thus by (12), (13), p. 361,

$$\begin{aligned} \int \cos \theta d\theta &= \sin \theta + C, \\ \int \sec^2 \theta d\theta &= \tan \theta + C. \end{aligned} \quad (18)$$

Observe that the first of these results is *not*  $-\sin \theta + C$ . We are not differentiating  $\cos \theta$ , but are finding a function *which, when differentiated, will yield  $\cos \theta$ .*

Some other forms are immediately reducible to known derivatives. For instance,  $\tan^2 \theta$  may be written  $(\sec^2 \theta - 1)$  and then integrated. Thus

$$\int \tan^2 \theta d\theta = \int (\sec^2 \theta - 1) d\theta = \tan \theta - \theta + C. \quad (19)$$

\* If time is lacking, the integrations may be confined to the sine and cosine.

Observe that the integral of  $\tan^2 \theta$  is not  $\frac{1}{3} \tan^3 \theta$ . Differentiating the latter would give  $\tan^2 \theta$  but *multiplied by the derivative of  $\tan \theta$ , viz.  $\sec^2 \theta$* .

Similarly the integral of  $\sin^2 \theta$  would not be  $\frac{1}{3} \sin^3 \theta$  (nor  $\cos^2 \theta$ , etc.), but a very different form, found later (Ex. I, p. 385).

By §§ 77, 101, a power of a quantity (whether a trigonometric function or something else) can be integrated, without changing its form, only if we have present besides the power the derivative of the quantity which is raised to the power. Any power of  $\tan \theta$  can be integrated if it is multiplied by  $\sec^2 \theta d\theta$ ; likewise any power of  $\sin \theta$  if multiplied by  $\cos \theta d\theta$ . And so on. [See Ex. II below.]

The systematic integration of trigonometric expressions of all sorts is treated in texts on Calculus. Tables of integrals are available, covering many forms. (§ 286.)

**Ex. I.** An alternating electric current varied thus:  $i = 17 \sin 200 t$ . Find the quantity of electricity transmitted in any time.

The intensity of the current is the rate of flow:  $i = dq/dt$ .

$$\therefore q = \int i dt = 17 \int \sin 200 t dt = \frac{-17}{200} \cos 200 t + C.$$

Since  $q = 0$  when  $t = 0$ ,  $C = \frac{17}{200} \cos 0 = \frac{17}{200}$ .

$$\therefore q = \frac{17}{200} (1 - \cos 200 t).$$

Check this result by differentiating; also by substituting  $t = 0$ .

**Ex. II.** Find  $\int \sin^3 \theta \cos \theta d\theta$ .

Since  $\cos \theta d\theta$  is the differential of  $\sin \theta$ , this is like having  $u^3 du$  to integrate, which would give  $u^4/4$ , — the  $u$  being  $\sin \theta$ .

$$\therefore \int \sin^3 \theta \cos \theta d\theta = \frac{1}{4} \sin^4 \theta + C. \quad (\text{Check?})$$

### EXERCISES

1. Draw by inspection a graph for each of the following quantities, showing a few waves, the value at  $t = 0$ , and the values of  $t$  where the function is zero. Also find at what time the first maximum and minimum are reached.



- (a) An alternating current died out thus:  $i = 10 e^{-200t} \cos 400 t$ ;
- (b) Another died out thus:  $i = 30 e^{-60t} \sin 200 t$ ;
- (c) The displacement of a pendulum thus:  $\theta = .2 e^{-.05t} \sin 2 \pi t$ ;
- (d) The elevation of a wave in water thus:  $y = 3 e^{-2t} \sin 3 t$ ;
- (e) The displacement of a tuning-fork thus:  $x = .08 e^{-t} \cos 800 t$ .

2. Integrate:  $\sin 10 t dt$ ;  $\cos 5 t dt$ ;  $7 \sin 80 t dt$ ;  $.4 \cos .1 t dt$ . Check each result by differentiation.

3. An alternating current varied thus under steady conditions:  $i = 10 \sin 400 t$ . Find  $i$  and  $di/dt$  when  $t = .003$ . Also find the quantity of electricity passed from  $t = 0$  to  $t = .003$ .

4. The angular speed of a pendulum varied thus:  $\omega = .1 \pi \cos \pi t$ . Find the angle swung through, from  $t = 0$  to any time.

5. Show that the following integrals are special cases of  $\int u^n du$ , and find each:

- (a)  $\int \sin^7 \theta \cos \theta d\theta$ ,
- (b)  $\int \tan^4 \theta \sec^2 \theta d\theta$ ,
- (c)  $\int \frac{\cos \theta d\theta}{\sin^4 \theta}$ ,
- (d)  $\int \frac{\sec^2 \theta d\theta}{\tan \theta}$ .

6. Simplify and integrate:

- (a)  $\int \frac{(2 \sin \theta \cos \theta - \cos \theta) d\theta}{1 - \sin \theta + \sin^2 \theta - \cos^2 \theta}$ ,
- (b)  $\int (\sqrt{1 + \cos \theta} + \sqrt{1 - \cos \theta})^2 d\theta$ .

7. (a)-(h). Integrate the expressions in Ex. 2 (a)-(h), p. 371.

§ 280. **Addition Formulas.** For various purposes we need to know how the sine of the sum of two angles ( $A + B$ ) is related to the functions of the two separate angles,  $A$  and  $B$ .

Fig. 132 illustrates the case where ( $A + B$ ) is an acute angle. From any point  $P$  on the terminal line of ( $A + B$ ), perpendiculars are dropped to the initial line and to the terminal line of  $\angle A$ ; and, from  $Q$ , the foot of the latter,

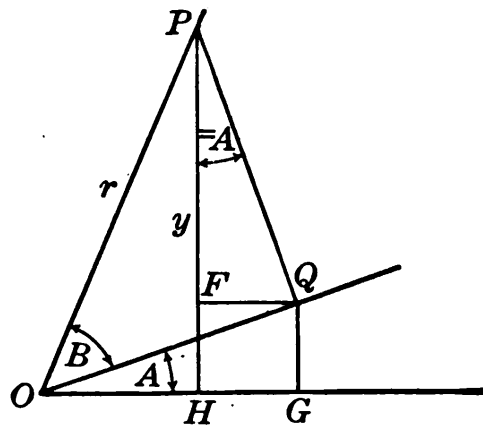

FIG. 132.

perpendiculars are dropped to the initial line and to the first perpendicular. Then, by definition,

$$\sin (A+B)=\frac{y}{r}. \quad (20)$$

The construction divides  $y$  or  $HP$  into two parts:  $HF(=GQ)$  and  $FP$ . Also it makes  $\angle FPQ = \angle A$ . (Why?) Solve  $\triangle GQO$  for  $GQ$ , and  $\triangle FPQ$  for  $FP$ , — using the sine or cosine of  $A$ , — and you will find that

$$GQ = OQ \sin A, \quad FP = PQ \cos A.$$

Substituting the sum of  $GQ$  and  $FP$  for  $y$  in (20) gives

$$\sin (A+B)=\frac{OQ \sin A+PQ \cos A}{r}.$$

But  $OQ/r = \cos B$ ,  $PQ/r = \sin B$ , whence

$$\sin (A+B)=\sin A \cos B+\cos A \sin B. \quad (21)$$

In words, *the sine of the sum of two angles equals the sine of the first times the cosine of the second, plus the cosine of the first times the sine of the second.*

*E.g.*,  $\sin (45^{\circ}+30^{\circ})=\sin 45^{\circ} \cos 30^{\circ}+\cos 45^{\circ} \sin 30^{\circ}$ .

Thus  $\sin 75^{\circ}$  can be calculated from the functions of  $45^{\circ}$  and  $30^{\circ}$ , which are known from simple right triangles.

In like manner, starting with  $\cos (A+B)=OH/r$ , and replacing  $OH$  by  $OG-FQ$ , we find

$$\cos (A+B)=\cos A \cos B-\sin A \sin B. \quad (22)$$

Verbal statements of (21) and (22) should be memorized very carefully.

*Remark.* So far (21) and (22) have been established only when  $(A+B)$  is acute. In the Appendix, p. 488, they are proved valid for any angles  $A$  and  $B$  whatever. Incidentally it is shown that

$$\sin (A-B)=\sin A \cos B-\cos A \sin B, \quad (23)$$

$$\cos (A-B)=\cos A \cos B+\sin A \sin B. \quad (24)$$

Observe that these formulas are just like (21) and (22) except for the sign in the middle on both sides. If we remember this fact, it will suffice to memorize (21) and (22) alone.

**§ 281. Some Applications.** The addition formulas (21)–(24), above, are useful in making simplifications, in solving equations, in studying simple harmonic motion, in calculating tables (§ 318) and in other ways.

**Ex. I**            Expand  $x = 10 \cos\left(kt - \frac{\pi}{3}\right)$ .

By (24),                             $x = 10 (\cos kt \cos \pi/3 + \sin kt \sin \pi/3)$ .

But by tables                     $\cos \pi/3 = .5$  and  $\sin \pi/3 = .86603$ .

$$\therefore x = 5 \cos kt + 8.6603 \sin kt.$$

That is, the *S. H. M.*,  $x = 10 \cos(kt - \pi/3)$ , is equivalent to two *S. H. M.*'s,  $x = 5 \cos kt$ , and  $x = 8.6603 \sin kt$ , combined.

**Ex. II.** In Fig. 133,  $X$  and  $Y$  are components of  $F$ . As these are physically equivalent to  $F$ , their combined effect along any other line  $OP$  should equal the effect of  $F$  along that line. Let us see whether this checks by actual calculation.

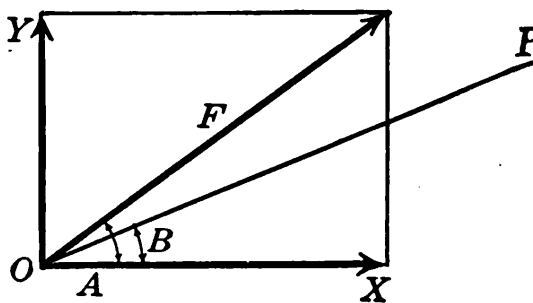

FIG. 133.

Effects of  $X$  and  $Y$  along  $OP$ :

$$X \cos B, \quad Y \cos (90^\circ - B).$$

Or, since  $X = F \cos A$  and  $Y = F \sin A$ , and since  $\cos (90^\circ - B) = \sin B$ , these amount to

$$F \cos A \cos B + F \sin A \sin B.$$

But the effect of  $F$  along  $OP$  by Fig. 133 is  $F \cos (A - B)$ ; and expanding the latter cosine by (24), we get the same result as from the effects of  $X$  and  $Y$ .

**§ 282. Multiple Angles.** Expanding  $\sin (\theta + \theta)$  and  $\cos (\theta + \theta)$  by the Addition Formulas (21) and (22) we find

$$\sin 2 \theta = 2 \sin \theta \cos \theta, \tag{25}$$

$$\cos 2 \theta = \cos^2 \theta - \sin^2 \theta. \tag{26}$$

In like manner we can apply the Addition Formulas to reduce functions of any multiple of  $\theta$  to functions of  $\theta$ .

Such formulas are frequently used in scientific work, particularly (25) and (26).

Ex. I. The range of a certain gun varies with the elevation  $\theta$  thus:

$$R = 40000 \sin \theta \cos \theta.$$

What elevation gives a range of 10000 ft.? The maximum range?

By (25) the formula may be re-written

$$R = 20000 \sin 2\theta.$$

Hence to make  $R = 10000$ , we need merely make  $\sin 2\theta = .5$ ; *i.e.*,

$$2\theta = 30^\circ \text{ or } 150^\circ,$$

$$\therefore \theta = 15^\circ \text{ or } 75^\circ. \quad (\text{Cf. Ex. I, § 271.})$$

$R$  will be greatest when  $\sin 2\theta$  is. This will be when the angle  $2\theta$  is  $90^\circ$ , or  $\theta = 45^\circ$ . Then  $R = 20000$ .

### EXERCISES

1. Carry out in detail all the steps of the derivations of (21) and (22) above.
2. Using formulas (21) and (22) and the values of the sine and cosine of  $1^\circ$  and  $2^\circ$  as given in the tables, calculate  $\sin 3^\circ$  and  $\cos 3^\circ$ .
3. From the functions of  $1'$  calculate  $\sin 2'$  and  $\cos 2'$ .
4. Knowing  $\sin 45^\circ = \frac{1}{2}\sqrt{2}$  and  $\sin 30^\circ = \frac{1}{2}$ , calculate  $\sin 75^\circ$ , also  $\sin 15^\circ$ .
5. Derive formulas (25) and (26) in detail. Write verbal statements for these, — as “The sine of twice any angle equals . . .,” etc.
6. Show that the area cut from a circle of radius  $r$  by a chord which subtends an angle  $\theta$  at the center is:  $A = \frac{1}{2} r^2(\theta - \sin \theta)$ .
7. Derive a formula for  $\cos 3\theta$ , in terms of  $\cos \theta$ .
8. Expand and simplify the following:
 

(a) $\sin(90^\circ + A)$ ,	(b) $\cos(180^\circ - A)$ ,
(c) $\sin(45^\circ + A)$ ,	(d) $\cos(60^\circ - A)$ .
9. Given  $\sin A = \frac{3}{5}$ ,  $\cos B = \frac{5}{13}$ ,  $A$  and  $B$  acute, find  $\sin(A+B)$  and  $\cos(A-B)$ .
10. The same as Ex. 9, but with neither  $A$  nor  $B$  in Quadrant I.

11. Simplify: (a)  $\sin(A+B) - \sin(A-B)$ ,  
 (b)  $\frac{\sin 7\theta + \sin 3\theta}{\cos 7\theta + \cos 3\theta}$ . [Hint:  $7\theta = (5\theta + 2\theta)$ ;  $3\theta = (5\theta - 2\theta)$ .]  
 (c)  $\cos(A+B)\cos B + \sin(A+B)\sin B$ .
12. Expand and simplify:  $x = 10 \sin(3t + 30^\circ)$ .
13. The same as Ex. 12 for the following:
- (a)  $x = 7 \cos(5t + 80^\circ)$ , (b)  $x = C \sin(400t - A)$ .

14. For what values of  $c$  and  $A$  would  $x = c \cos(20t - A)$  give the expanded form  $x = 8 \cos 20t + 6 \sin 20t$ ?

§ 283. **Half-angle Formulas.** Combining (26) with the identity  $1 = \cos^2 \theta + \sin^2 \theta$ , we find

$$\begin{aligned}\sin^2 \theta &= \frac{1}{2}(1 - \cos 2\theta), \\ \cos^2 \theta &= \frac{1}{2}(1 + \cos 2\theta).\end{aligned}\tag{27}$$

These two formulas should be carefully memorized as they are used in many calculations, reductions, and integrations.

Ex. I. Integrate  $\sin^2 \theta d\theta$ .

By (27):

$$\int \sin^2 \theta d\theta = \frac{1}{2} \int (1 - \cos 2\theta) d\theta = \frac{1}{2} \theta - \frac{1}{4} \sin 2\theta + C.$$

Ex. II. Knowing  $\cos 30^\circ = .86603$ , calculate  $\cos 15^\circ$ .

When  $\theta = 15^\circ$ , formula (27) gives  $\cos 15^\circ = \sqrt{\frac{1}{2}(1 + \cos 30^\circ)}$ ;

$$\text{i.e.,} \quad \cos 15^\circ = \sqrt{.93302} = .96593.$$

The tables were originally calculated partly by this method. (How could it be continued?)

Formulas (27) give the sine and cosine for half of any known angle  $2\theta$ , and are called "Half-angle Formulas." Often they are written

$$\begin{aligned}\sin^2 \left(\frac{1}{2} A\right) &= \frac{1}{2}(1 - \cos A), & \cos^2 \left(\frac{1}{2} A\right) &= \frac{1}{2}(1 + \cos A), \\ \text{or } \sin \frac{1}{2} A &= \pm \frac{\sqrt{1 - \cos A}}{2}, & \cos \frac{1}{2} A &= \pm \frac{\sqrt{1 + \cos A}}{2}.\end{aligned}\tag{28}$$

§ 284. **Angle between Two Curves.** The tangent of the difference of two angles is easily found from the sine and cosine :

$$\tan (A - B) = \frac{\sin (A - B)}{\cos (A - B)} = \frac{\sin A \cos B - \cos A \sin B}{\cos A \cos B + \sin A \sin B}.$$

Dividing both numerator and denominator by  $\cos A \cos B$  gives

$$\tan (A - B) = \frac{\tan A - \tan B}{1 + \tan A \tan B} \quad (29)$$

which expresses  $\tan (A - B)$  in terms of tangents only.

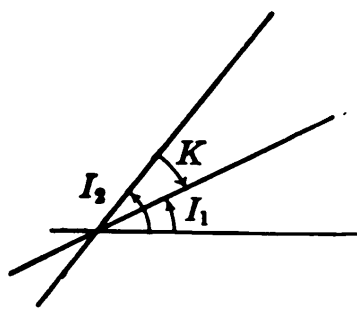

FIG. 134.

This is useful in finding the angle ( $K$ ) between two lines or curves. For  $K$  is the difference between the inclination angles  $I_2$  and  $I_1$  at the point where the curves cross.

$$\therefore \tan K = \frac{\tan I_1 - \tan I_2}{1 + \tan I_2 \tan I_1} \quad (30)$$

Now  $\tan I$  is the slope of a curve,  
 $= l, = dy/dx.$

Hence the angle  $K$  can be found by (30) directly from the slopes or derivatives without first looking up the two separate angles.

### EXERCISES

1. (a) Show how to integrate  $\cos^2 \theta$  and  $\sin^2 \theta$ . (b) What would you suggest for  $\sin^2 (3 \theta)$ ? For  $\cos^2 (7 \theta)$ ?
2. In a right triangle one leg is  $b = 999.95$  and the hypotenuse is 1000. Try to find  $\angle A$  directly, but also solve by using the formula  $\sin^2 (A/2) = \frac{1}{2} (1 - \cos A)$ .
3. Knowing  $\cos 45^\circ = \frac{1}{2}\sqrt{2} = .70711$ , calculate  $\cos 22^\circ 30'$  and  $\cos 11^\circ 15'$ . Explain how you could also calculate  $\cos 67^\circ 30'$ , and from it  $\cos 33^\circ 45'$ , etc.
4. From formulas (28) derive the formulas: (A)  $\tan \frac{1}{2} \theta = \sin \theta / (1 + \cos \theta)$ ; (B)  $\tan \frac{1}{2} \theta = (1 - \cos \theta) / \sin \theta$ .
5. Obtain formulas for  $\cotn \frac{1}{2} \theta$ , similar to those in Ex. 4.
6. Derive a formula for  $\tan (A + B)$  in terms of  $\tan A$  and  $\tan B$ .

7. What is the angle between two straight lines if their slopes are:  
 (a) 3 and 2; (b) 7 and  $-5$ ; (c) 4 and  $-5$ ?
8. Where does  $y = x^2$  meet  $x^2 + y^2 = 20$ , and at what angle do they cross each other? Draw a rough figure by inspection.
9. The same as Ex. 8 for  $xy = 12$  and  $2x - 3y = 6$ .

§ 285. **Sums, Differences, and Products.** With the help of the Addition Formulas, it is easy to change sums and differences of certain functions to product forms which are more convenient for some purposes.

*E.g.*, suppose we wish to change \*  $\sin 40^\circ - \sin 28^\circ$  to a product.

Let  $A$  and  $B$  be two angles whose sum is  $40^\circ$  and whose difference is  $28^\circ$ :

$$\begin{aligned} A + B &= 40^\circ, \\ A - B &= 28^\circ. \end{aligned} \quad \therefore \begin{cases} A = 34^\circ, \\ B = 6^\circ. \end{cases}$$

Then

$$\begin{aligned} \sin 40^\circ &= \sin (A + B) = \sin A \cos B + \cos A \sin B, \\ \sin 28^\circ &= \sin (A - B) = \sin A \cos B - \cos A \sin B. \end{aligned}$$

$$\therefore \sin 40^\circ - \sin 28^\circ = 2 \cos A \sin B = 2 \cos 34^\circ \sin 6^\circ.$$

(Q. E. F.)

The same method can be used to prove the following formulas: †

$$\sin u + \sin v = 2 \sin \frac{1}{2}(u+v) \cos \frac{1}{2}(u-v); \quad (31)$$

$$\sin u - \sin v = 2 \cos \frac{1}{2}(u+v) \sin \frac{1}{2}(u-v); \quad (32)$$

$$\cos u + \cos v = 2 \cos \frac{1}{2}(u+v) \cos \frac{1}{2}(u-v); \quad (33)$$

$$\cos u - \cos v = -2 \sin \frac{1}{2}(u+v) \sin \frac{1}{2}(u-v). \quad (34)$$

\* Observe that this is not  $\sin (40^\circ - 28^\circ)$ .

† If you expect to work in higher mathematics or engineering, memorize statements of these formulas in words: "The sum of two sines equals *twice the sine of half the sum* (of the angles) *times the cosine of half the difference.*" Etc.

A method of going from the product form to a sum or difference is shown in Ex. III below.

Ex. I. Solve for  $x$ :  $\sin 3x + \sin x = \sin 2x$ .

By (31),  $\sin 3x + \sin x = 2 \sin 2x \cos x$ .

$$\therefore 2 \sin 2x \cos x = \sin 2x$$

This gives  $\cos x = .5$ , or else  $\sin 2x = 0$ . (§ 63.)

Hence  $x = 60^\circ, 300^\circ$ , etc. Or else  $2x = 0^\circ, 180^\circ$ , etc.; *i.e.*,  $x = 0, 90^\circ, 180^\circ$  etc.

Ex. II. Simplify  $y = \frac{\sin 60^\circ - \sin 10^\circ}{\cos 60^\circ + \cos 10^\circ}$ .

By (32) and (33):  $\sin 60^\circ - \sin 10^\circ = 2 \cos 35^\circ \sin 25^\circ$ ; and  $\cos 60^\circ + \cos 10^\circ = 2 \cos 35^\circ \cos 25^\circ$ . Thus  $y = \tan 25^\circ$  simply.

Ex. III. Integrate  $\cos 4x \cos x \, dx$ .

We first change the product to a sum or difference. As the product involves only cosines, it comes under (33),  $4x$  being half the sum, and  $x$  half the difference of the angles. Hence  $u + v = 8x$ ,  $u - v = 2x$ , giving  $u = 5x$ ,  $v = 3x$ .

$$\therefore \cos 4x \cos x = \frac{1}{2} (\cos 5x + \cos 3x).$$

We can now integrate each term, getting

$$\frac{1}{2} \left[ \frac{1}{5} \sin 5x + \frac{1}{3} \sin 3x \right] + C.$$

### EXERCISES

1. Derive in detail formulas (31)–(34).

2. Transform into products and simplify:

(a)  $\frac{\sin 5\theta - \sin 3\theta}{\cos 5\theta - \cos 3\theta}$ ,

(b)  $\frac{\sin 8\theta + \sin 4\theta}{\cos 8\theta + \cos 4\theta}$ ,

(c)  $\frac{\sin 50^\circ - \sin 10^\circ}{\sin 50^\circ + \sin 10^\circ}$ ,

(d)  $\frac{\cos 30^\circ - \cos 20^\circ}{\cos 30^\circ + \cos 20^\circ}$ .

3. Transform into sums or differences:

(a)  $\sin 6\theta \cos 4\theta$ ,

(b)  $\cos 8\theta \sin 6\theta$ .

4. Show that  $\int \cos 7\theta \cos 3\theta \, d\theta = \frac{1}{2\theta} \sin 10\theta + \frac{1}{\theta} \sin 4\theta + c$ .

§ 286. **Tables of Integrals.** By various methods numerous integrals have been worked out and tabulated. Thus many integrals needed in practical work can be looked up in a table without working them out for ourselves.



There is a small table in the Appendix, pages 494–497. Larger ones are given in texts on Calculus; also separately.\*

Ex. I. Find  $\int \sec^3 x \, dx$ .

This comes under (39), p. 497, with  $n=3$  and  $a=1$ :

$$\therefore \int \sec^3 x \, dx = \frac{1}{2} \sin x \sec^2 x + \frac{1}{2} \int \sec x \, dx.$$

The latter integral is given in (9) of the table; viz.,  $\log (\sec x + \tan x)$ . (Formulas like (39) are called *Reduction-Formulas*.)

Ex. II. Find  $\int \frac{x \, dx}{\sqrt{x^4+9}}$ .

Clearly  $x \, dx$  suggests  $x^2$ , as does also the *even* power,  $x^4$ . Putting  $x^2=t$ , gives  $x \, dx = \frac{1}{2} dt$ , and

$$\int \frac{x \, dx}{\sqrt{x^4+9}} = \frac{1}{2} \int \frac{dt}{\sqrt{t^2+9}}$$

This comes under (23), with  $a=3$ .

$$\therefore \int \frac{x \, dx}{\sqrt{x^4+9}} = \frac{1}{2} \log (t + \sqrt{t^2+9}) = \frac{1}{2} \log (x^2 + \sqrt{x^4+9}).$$

### EXERCISES

1. Find from tables the integrals of the following:

- |  |                                  |  |
|--|----------------------------------|--|
| (a) $\frac{dx}{\sqrt{16-x^2}}$ ,                         | (b) $\sqrt{x^2-25} \, dx$ ,      | (c) $\frac{dx}{(x^2+9)^{\frac{3}{2}}}$ . |
| (d) $\sin^{\frac{5}{2}} \theta \cos \theta \, d\theta$ , | (e) $\tan^6 \theta \, d\theta$ , | (f) $\sec^5 \theta \, d\theta$ .         |
| (g) $\sin 3 \theta \cos \theta \, d\theta$ ,             | (h) $x^2 \log x \, dx$ ,         | (i) $e^{-2t} \sin 3 t \, dt$ .           |

2. Find by integration the area of the ellipse:  $4x^2+9y^2=36$ .

3. Find the volume generated by revolving about the  $X$ -axis the area under one arch of the sine curve. (Radian measure.)

§ 287. **Summary of Chapter XI.** The basic formulas derived in this chapter may be classified as follows: (I) Formulas involving a single angle only; (II) Addition formulas; (III) Half-angle formulas; (IV) Conversion formulas for sums and products; (V) Differentiation formulas.

\* B. O. Peirce, *A Short Table of Integrals*, gives several hundred forms and is sufficiently complete for all ordinary purposes.

All of these should be carefully memorized if you expect to use mathematics extensively as a working tool. In any case it will pay to make a full list of the uses of each set of formulas, so far as shown. The integrals of the several functions, so far as obtained, need not be memorized; but the methods by which they were obtained should be familiar.

We shall next turn to a further study of the uses of integration, and methods of setting up integrals.

### EXERCISES

1. Prove the identities:

$$(a) \sin^2 \theta + \tan^2 \theta = \sec^2 \theta - \cos^2 \theta, \quad (b) \frac{\tan 2\theta + \tan \theta}{\tan 2\theta - \tan \theta} = \frac{\sin 3\theta}{\sin \theta}.$$

2. Given  $\csc A = -\frac{1}{3}$  and  $\sec B = \frac{1}{2}$ , with  $A$  and  $B$  in the same quadrant. Find all the functions of  $A - B$ .

3. A "synmotor" plows a spiral furrow, being drawn steadily inward by a cable which winds up on a cylindrical "drum." What kind of curve is this spiral, by definition?

4. A point moved in such a way that  $x = 10 \cos t$ ,  $y = 8 \sin t$ . Find the speed at any instant; also what kind of curve the path was.

5. From the formulas for  $\sin(A+B)$  and  $\cos(A+B)$  derive a formula for  $\sin 3\theta$  in terms of  $\sin \theta$  alone.

6. Telephone wires,  $h$  feet above the ground, exert a horizontal pull of  $P$  pounds on each pole. The last pole is strengthened by a guy wire  $l$  feet long inclined  $\theta^\circ$ , not reaching the top. Show by § 116 that for a perfect balance  $Ph = Fl \sin \theta \cos \theta$ , where  $F$  is the force along the guy. Find what value of  $\theta$  will make  $F$  least,  $l$  being constant.

7. The time required for a small force ( $F$  lb.) to raise a 100-pound weight 30 feet by pulling it up a smooth plane, of inclination  $\theta$ , is  $T = \sqrt{60/D}$ , where  $D = \sin \theta (F - 100 \sin \theta)$ . What value of  $\theta$  will make  $T$  a minimum? (Hint: Simply make the denominator  $D$  a maximum.)

8. Along the "great circle" from San Francisco to Manila, the latitude  $L$  varies with the longitude  $\theta$  thus:  $\tan L = .24 \sin \theta - .95 \cos \theta$ , approx. Does the circle pass north or south of Honolulu ( $\theta = 157^\circ 50'$ ,  $L = 21^\circ 20'$ )? How much does  $L$  change with  $\theta$ , per degree, at  $\theta = 150^\circ$ ? (Differentiate implicitly. § 80.)

9. Find an equation of the form  $\tan L = c \sin(\theta - A)$ , which is equivalent to the equation given in Ex. 8. [Hint: Expand  $\sin(\theta - A)$  and compare.]

10. Two halls 17.28 feet wide and 10 feet wide meet at right angles. Find how long a pole can be carried from one into the other, while kept horizontal. (Hint: Show that the shortest distance across at the turn is expressible in the form  $17.28 \csc \theta + 10 \sec \theta$ .)

11. In just what direction should the wind blow to make the sum of its eastward and northward velocities a maximum, — the actual velocity of the wind being constant?

12. When a ship sails "into the wind," the driving force is approximately proportional to  $\sin \theta \sin (A - \theta)$ , where  $A$  is the angle between the course of the ship and wind's direction (reversed), and  $\theta$  is the angle between the wind and the sail. Find what value of  $\theta$  gives the maximum force.

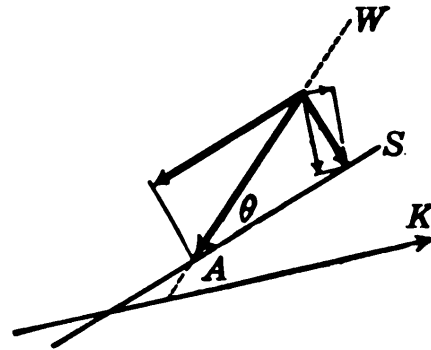

FIG. 135.

W, wind; S, sail; K, keel.

13. A right triangle has a horizontal hypotenuse 20 ft. long. Show that its area is  $A = 200 \sin I \cos I$ , where  $I$  is the inclination of either leg. For what  $I$  will  $A$  be greatest?

14. Along every great circle of the earth the latitude ( $L$ ) varies with the longitude ( $\theta$ ) according to the formula

$$\tan L = a \sin \theta + b \cos \theta,$$

where  $a$  and  $b$  depend on the course of the circle in question. Find  $a$  and  $b$  if the circle is to pass through St. Johns, N. F. ( $\theta = 52^\circ 40'$ ,  $L = 47^\circ 40'$ ), and the Azores ( $\theta = 29^\circ$ ,  $L = 38^\circ$ ). If an airplane is to fly over this course, what should its latitude be when in longitude  $36^\circ$ ?

15. The same as Ex. 14 for a great circle from St. Johns to Queens-town ( $\theta = 8^\circ 20'$ ,  $L = 51^\circ 50'$ ).

16. Where would the circle in Ex. 8 above cross the equator? Where does it go farthest north?

## CHAPTER XII

### DEFINITE INTEGRALS

#### THE SUMMATION OF MINUTE ELEMENTS

§ 288. **Constant of Integration.** We proceed now to note certain facts about integration which will enable us to apply it more easily to practical problems. And first we shall shorten somewhat the calculation of areas, volumes, etc., by observing that the constant of integration and the final result must always assume a certain *form*.

Consider for example the area under the curve  $y=1/x$  from  $x=2$  to  $x=7$ .

$$A = \int y \, dx = \int \frac{1}{x} \, dx = \log x + C.$$

Since  $A=0$  when  $x=2$ , we have  $0 = \log 2 + C$ , or

$$C = -\log 2. \tag{1}$$

Hence the area from  $x=2$  to any other value of  $x$  is

$$A = \log x - \log 2.$$

In particular, the area from  $x=2$  to  $x=7$  is

$$A = \log 7 - \log 2.$$

Similarly the area from  $x=3$  to  $x=11$  would be  $\log 11 - \log 3$ .

The final result is simply the *difference between the values of the integral function* at the beginning and end of the interval.

Clearly the same thing must be true for the area under any other graph. For the constant of integration must equal the value of the integral at the starting point, — with the sign changed.

§ 289. **Definite Integrals.** The symbol

$$\int_a^b f(x) dx,$$

is used to denote the *difference of the values of the integral function at  $x=b$  and at  $x=a$* . It is called "the definite integral from  $a$  to  $b$  of  $f(x) dx$ "; and  $a, b$  are called the *limits of integration*.\*

This difference is also denoted by writing the symbol  $\int_a^b$  after the integral function. Thus

$$\int_a^b x^2 dx = \left. \frac{1}{3} x^3 \right|_a^b = \frac{1}{3} b^3 - \frac{1}{3} a^3.$$

$$\int_2^7 \frac{1}{x} dx = \left. \log x \right|_2^7 = \log 7 - \log 2.$$

§ 290. **Calculations Abridged.** By § 288 the area under a curve may be expressed in the form

$$A = \int_a^b y dx. \quad (2)$$

Similar reasoning shows that the volume of a solid, the work done by a varying force, etc., are simply :

$$V = \int_a^b A_x dx, \quad W = \int_a^b f dx, \text{ etc.} \quad (3)$$

That is, in finding any such quantity we need not consider the constant of integration, but merely form the difference of two values of the integral.

Ex. I. Find the momentum generated from  $t=2$  to  $t=5$  by a force varying thus:  $f = 100 t - 12 t^2$ .

$$M = \int_2^5 f dt = \int_2^5 (100 t - 12 t^2) dt$$

$$= 50 t^2 - 4 t^3 \Big|_2^5 = 750 - 168 = 582.$$

\* An ordinary integral function involving an arbitrary constant is sometimes called an *indefinite* integral.

*Remark.* The constant of integration is present here in disguise, already determined, in the term  $-168$ . [Cf. (1), § 288.]

## EXERCISES

1. Evaluate:  $\int_1^5 6x^2 dx$ ,  $\int_{-3}^3 x^4 dx$ ,  $\int_0^2 e^{3x} dx$ ,  $\int_0^{\frac{\pi}{2}} \cos x dx$ .
2. Find the area under one arch of the sine curve, plotted in radian measure (Fig. 122, p. 355).
3. Find the area under the curve  $y = 1/\sqrt{x}$  from  $x = 4$  to  $x = 9$ .
4. Find the work done by a gas in driving a piston from  $x = 20$  to  $x = 60$  if  $F = 1200/x$  continually.
5. The force applied to a car varied thus:  $F = 60t^2 - t^3$ . Find the momentum generated between  $t = 10$  and  $t = 20$ .
6. How much water must flow into a hemispherical cistern of radius 7 ft. to raise the depth (at the middle) from 3 ft. to 5 ft.?
7. Find the volume generated by revolving about the  $X$ -axis the area under the curve  $y = \tan x$  (Fig. 124, p. 356) from  $x = 0$  to  $x = \pi/4$ .

*Note.* In Exs. 8–9, find the integrals from tables.

8. A “conoid” has circular base of radius 10 in. Every section perpendicular to one diameter is an isosceles triangle, whose height is 15 in. Find the volume.
9. A cylindrical tank of radius 5 ft., lying horizontally, is half full of oil which weighs 60 lb. per cu. ft. Find the pressure against one end.
- [10.] Plot the curve  $y = x^2 + 1$  from  $x = 0$  to  $x = 2$ , drawing the ordinates at  $x = 0, .5, 1.0$ , etc. Calculate the total area of the four rectangles inscribed under the curve in these strips. Likewise find the area for a similar set of 10 inscribed rectangles with bases  $x = 0$  to  $.2, .2$  to  $.4$ , etc. Compare the results with the area under the curve from  $x = 0$  to  $2$ , as found by integration.

**§ 291. Fundamental Theorem.** We proceed now to establish a theorem of the very greatest importance.

Let  $y$  be any quantity which varies continuously with  $x$ , and let  $y_1, y_2, \dots, y_n$ , be its values taken at equal intervals  $\Delta x$  from  $x = a$  to  $x = b$ . Multiply each of these values by  $\Delta x$ , and consider the sum of the products:

$$y_1 \Delta x + y_2 \Delta x \cdots + y_n \Delta x.$$

If  $\Delta x \rightarrow 0$ , this sum will approach a limit, — that limit being the definite integral  $\int_a^b y dx$ ; i.e.,

$$\lim_{\Delta x \rightarrow 0} (y_1 \Delta x + y_2 \Delta x \cdots + y_n \Delta x) = \int_a^b y dx. \quad (4)$$

PROOF. The several products  $y_1 \Delta x$ ,  $y_2 \Delta x$ , etc.; are equal to the areas of rectangles inscribed in the graph of the varying quantity  $y$  (Fig. 136). And the limit of the sum of those rectangles as their number is indefinitely increased is precisely the area under the graph, or the definite integral in (4).

This theorem has been stated abstractly but is of great practical importance, for it shows that

Any quantity whatever, which is expressible as the limit of a sum, of the type in (4), is therefore, without further argument, equal to a definite integral, as in (4).

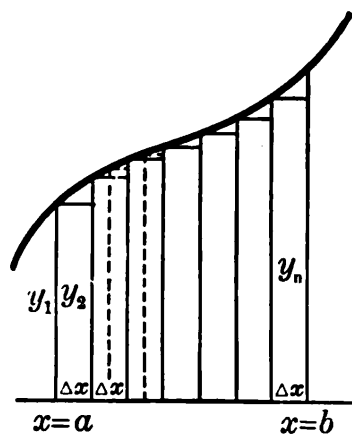

FIG. 136.

By means of this “ Fundamental Theorem ” we can easily set up many integrals. Consider, for instance, the volume of a solid. If cut into  $n$  slices of thickness  $\Delta x$  by parallel planes, the volume of each slice will be approximately its face-area  $A$  times  $\Delta x$ , and the entire volume approximately

$$A_1 \Delta x + A_2 \Delta x \cdots + A_n \Delta x,$$

or, exactly, the *limit* of this sum as  $\Delta x \rightarrow 0$ . Hence without further proof :

$$V = \int A dx. \quad (5)$$

This integral can be set up still more quickly by reasoning freely as in § 99. But the present argument is logically sound and exact.

**§ 292. Infinitesimal Analysis.** Integration as defined nowadays is the process of finding a quantity when given

its derivative or rate of increase. This was in essence the conception of Newton, who first devised the process.

We have now seen that integration is also a method of calculating the *limit of a sum* of a certain type. This is almost the point of view of Leibnitz, who shares with Newton the honor of having invented the calculus, and who considered integration simply as a method of summing.

For instance, he regarded the area under a curve as composed of exceedingly many "infinitesimal" strips, — so narrow that the height  $y$  does not change within a strip (!) Calling the base of each strip  $dx$  and the area of each  $y dx$ , the whole area was the sum of all these areas:

$$A = \int_a^b y dx, \quad (6)$$

the sign  $\int$  being simply an  $S$ , standing for "sum of."

We have already touched upon this conception (§ 99), and have seen that although logically defective it seems to work as a method of setting up integrals. We are now in a position to understand the matter more fully.

No matter how narrow a strip is, its height is not a fixed value  $y$ . Thus  $y dx$  is not the area of the strip, but of a rectangle inscribed in the strip. (Cf. Fig. 48, p. 143.)

The desired area is not the sum of the rectangles  $y dx$ , but the *limit* of that sum. *And the limit of the sum is the true integral* as we now define it. Thus Leibnitz set up a formula which is strictly correct in the sense in which we now use the sign.

Moreover he obtained strictly correct results by making another error which he saw would compensate for the first. Although he said that he was going to "sum up," actually he did not do so, but instead found the *limit* of the sum, — which is the thing he should have been seeking. In other words, he used rules for "summing" which were the same as our rules for integrating.



The relation between Leibnitz' method of setting up integrals and the strictly logical procedure may become clearer if we refer again to the case of the volume of a solid.

By the old conception, as noted in § 99, the slices are regarded as so thin that the volume of each equals its face-area  $A$  times its thickness  $dx$ , making the whole volume the sum of these elements  $A dx$ :

$$V = \int A dx.$$

What we should say, reasoning exactly as in § 291, is that the volumes of the slices are *approximately*

$$A_1 \Delta x, \quad A_2 \Delta x, \quad A_3 \Delta x, \dots;$$

that the entire volume  $V$  is approximately the sum of these, and *exactly* the *limit* of that sum, or by (4) the integral

$$V = \int A dx. \quad (7)$$

If the old method is regarded merely as a short way of stating the correct argument about the limit of a sum, and the person using it understands what he is doing, the old conception may properly be used in setting up integrals. Indeed it is the method regularly used by scientific men. The method, even if not "rigorous," is very "vigorous."

Of course the question arises as to when we can rely upon this older method to give a correct integral. The answer is simple: *Whenever the quantity under consideration is the limit of a sum of the type in (4), above.*

If for convenience we regard a quantity as a certain *sum*, when in reality it is the *limit* of that sum, and if we then actually work out the limit of the sum (by integrating), clearly we shall get an exact result.

### EXERCISES

1. Tell how an exact argument in terms of limits and theorem (4) above would run in setting up integrals (B) and (C) of § 99.
2. The same as Ex. 1 for the integrals of: (a) § 100; (b) § 102.

3. By considering "infinitesimal elements," and also by an exact argument, set up the integral in each of the following cases :

(a) The momentum generated by a variable force  $F$  ;

(b) Radium decomposes at a variable rate  $R$ , say  $R=f(t)$ . Write an expression for the total amount lost from  $t=t_1$  to  $t=t_2$ .

(c) A wound is healing at a variable rate,  $=F(t)$ . Express the total area healed in any time.

4. The density of the earth ( $D$  lb. per cu. mi.) varies with the distance ( $x$  mi.) from the center:  $D=F(x)$ . Express the total weight of the earth from  $x=0$  to 3960. [Hint: Regard a spherical shell in the interior as "so thin that it is all the same distance  $x$  ft. from the center"! Also give an exact argument.]

5. Plot the parabola  $y=x^2$  and the line  $y=3x+4$ , and measure the area bounded by them. Calculate the area by a single integral. [Hint: If the area be divided into "infinitesimal rectangles," running parallel to the  $Y$ -axis, what will be the length of any one in general?]

6. The same as Ex. 5 for the curves  $y=x^2$  and  $y^2=x$ .

7. A beam 30 feet long carries a load ( $L$  lb. per ft.) which varies thus with the distance ( $x$  ft.) from one end:  $L=120x-4x^2$ . Find the total load.

8. In Ex. 7 find the total moment of the load about the end mentioned. (§ 116.)

9. A horizontal semicircular plate of radius 10 ft. weighs 2 lb. per sq. ft. What is the total moment of its weight about its straight side?

10. Find the total weight of a circular plate of radius 5 in., if the weight per sq. in. varies thus with the distance ( $x$  in.) from the center:  $w=4-.2x$ . [Consider a narrow ring  $x$  in. from the center.]

11. Find the total weight of a rectangular plate 20 in. long and 4 in. wide if the weight per sq. in. varies thus with the distance ( $x$  in.) from one end:  $w=6+.4x$ .

12. A hemispherical cistern of radius 10 ft. is full of water. Find the work required to pump the water to a level 2 ft. above the top. [Hint: Consider a thin sheet of water at any distance ( $x$  ft.) below the top. Water weighs 62.5 lb./cu. ft. roughly.]

13. The speed of a car varies thus with the time:  $v=10t^2$ . Calculate the speed every 2 seconds from  $t=0$  to 10 inclusive, and by averaging the values numerically for each interval, calculate the approximate distance traveled. Repeat the calculation, getting the speed every half second. Compare the results with the exact distance found by integration.

§ 293. **Length of a Curve.** If  $PQ$  is a chord joining any two points of a smooth curve, then

$$\overline{PQ}^2 = \Delta x^2 + \Delta y^2 = \left[ 1 + \left( \frac{\Delta y}{\Delta x} \right)^2 \right] \Delta x^2.$$

But  $\Delta y/\Delta x$ , the slope of  $PQ$ , must equal  $dy/dx$ , the slope of the tangent, at some point on the arc  $PQ$ .

$$\therefore PQ = \sqrt{1 + \left( \frac{dy}{dx} \right)^2} \Delta x. \quad (8)$$

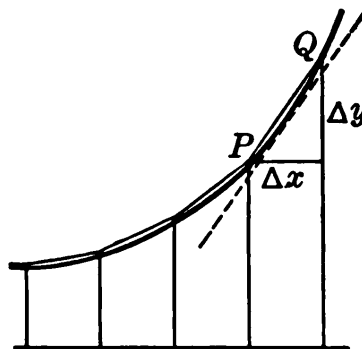

Now the length of the curve,  $s$ , is the *limit* of the sum of the lengths of its chords  $PQ$ , as each approaches zero:

$$s = \lim_{\Delta x \rightarrow 0} L \left\{ \sqrt{1 + \left( \frac{dy}{dx} \right)_1^2} \Delta x + \sqrt{1 + \left( \frac{dy}{dx} \right)_2^2} \Delta x + \dots \right\}.$$

Hence, by (4) above,  $s$  equals a definite integral.

$$s = \int_a^b \sqrt{1 + \left( \frac{dy}{dx} \right)^2} dx. \quad (9)$$

*E.g.*, for the curve  $y = x^3$ , we have  $dy/dx = 3x^2$ ,

$$\therefore s = \int \sqrt{1 + 9x^4} dx.$$

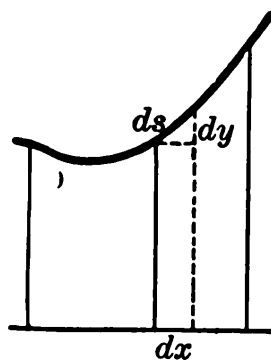

FIG. 137.

*Remark.* Using the brief “vigorous” method, we would consider any very short arc  $ds$  as straight, and as forming with  $dx$  and  $dy$  a right triangle. (Fig. 137.)

$$\therefore ds^2 = dx^2 + dy^2 = \left[ 1 + \left( \frac{dy}{dx} \right)^2 \right] dx^2.$$

Hence as in (9) above the entire length of the curve is

$$s = \int \sqrt{1 + \left( \frac{dy}{dx} \right)^2} dx.$$

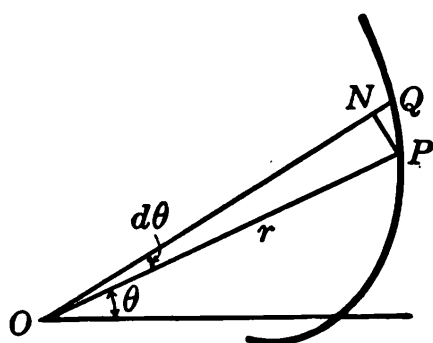

FIG. 138.

§ 294. **Length in Polar Coördinates.** Let us also express the length of a curve whose equation is given in polar coördinates.

(I) *Using the short "vigorous method."* When  $d\theta$  is infinitesimal, the circular arc  $PN$  (Fig. 138) is regarded as straight, and being perpendicular to its radius

$ON$ , it forms with  $PQ$  and  $NQ$  a right triangle (!), in which  $PQ = ds$ ,  $NQ = dr$ , and  $PN = r d\theta$ , if  $\theta$  is in radians. (§ 251.)

$$\therefore ds^2 = dr^2 + r^2 d\theta^2, \quad (10)$$

$$s = \int \sqrt{\left(\frac{dr}{d\theta}\right)^2 + r^2} d\theta. \quad (11)$$

(II) *Using an exact method.* In Fig. 138 let a straight line  $PN'$  be drawn perpendicular to  $OQ$ . Then

$$(\text{chord } PQ)^2 = \overline{PN'}^2 + \overline{N'Q}^2.$$

This may also be written

$$\left(\frac{PN'}{\text{arc } PN}\right)^2 (\text{arc } PN)^2 + \left(\frac{N'Q}{NQ}\right)^2 (NQ)^2,$$

or 
$$\left(\frac{PN'}{\text{arc } PN}\right)^2 (r\Delta\theta)^2 + \left(\frac{N'Q}{NQ}\right)^2 \Delta r^2,$$

or 
$$\left[\left(\frac{PN'}{\text{arc } PN}\right)^2 r^2 + \left(\frac{N'Q}{NQ}\right)^2 \left(\frac{\Delta r}{\Delta\theta}\right)^2\right] \Delta\theta^2.$$

Now the length of the curve is the limit of the sum of the lengths of the chords, as  $\Delta\theta \rightarrow 0$ . But the fractions  $PN'/\text{arc } PN$  and  $N'Q/NQ$  both approach 1. Hence  $s$  is the integral

$$s = \int \sqrt{r^2 + \left(\frac{dr}{d\theta}\right)^2} d\theta. \quad (12)$$

which agrees with (11).

§ 295. **Surfaces of Revolution.** When any curve  $y = f(x)$  is revolved about the  $X$ -axis, it generates some curved surface. Let us find the area  $S$  of this surface.

Using the short method, any tiny arc of the curve,  $ds$ , is regarded as generating a narrow band running around the surface, — of length  $2\pi y$  and width  $ds$ . The area of this tiny band of surface is then  $2\pi y ds$ . Or, substituting for  $ds$  its value (§ 293), we have as the surface :

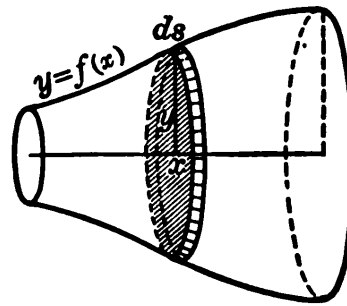

FIG. 139.

$$S = \int 2\pi y \sqrt{1 + \left(\frac{dy}{dx}\right)^2} dx. \quad (13)$$

This integral can also be set up by the “rigorous method” of limits; but far less simply.

To calculate the area of a general curved surface, which is not obtainable by revolving a plane curve, is a more difficult problem, which will not be treated in this course.

**Ex. I.** Find the area generated by revolving the parabola  $y^2 = 4x$  about the  $x$ -axis, from  $x=0$  to  $x=8$ .

$$\begin{aligned} y &= 2x^{\frac{1}{2}}, \quad \therefore dy/dx = x^{-\frac{1}{2}} = 1/\sqrt{x}. \\ \therefore S &= \int_0^8 4\pi x^{\frac{1}{2}} \sqrt{1 + \frac{1}{x}} dx = 4\pi \int_0^8 \sqrt{x+1} dx \\ &= \frac{8}{3} \pi (x+1)^{\frac{3}{2}} \Big|_0^8 = \frac{208}{3} \pi. \end{aligned}$$

### EXERCISES

*N.B. When necessary find the required integrals from tables.*

- Find the lengths of the following curves :
  - $y = \frac{2}{3}(x-1)^{\frac{3}{2}}$  from  $x=1$  to  $x=9$ .
  - The entire circle  $x^2 + y^2 = 25$ . (Check.)
  - The parabola  $12y = x^2$  from  $x=0$  to  $x=8$ .
- Find by integration the areas generated by revolving the following curves about the  $X$ -axis :
  - The cubical parabola  $y = x^3$ , from  $x=0$  to  $x=1$ .
  - The parabola  $y^2 = 4x$ , from  $x=3$  to  $15$ .
  - The line  $y = \frac{1}{2}x$ , from  $x=0$  to  $10$ . (Check by elementary geometry.)

(d) The line  $y=2x$ , from  $x=1$  to  $x=5$ . (Check.)

(e) The circle  $x^2+y^2=100$ . (Check.)

3. Express as an integral the area of the surface generated by revolving any given curve about the  $Y$ -axis.

4. Find the lengths of the following curves, each from  $\theta=0$  to  $\theta=\pi^{(r)}$ :

(a)  $r=3\theta$ ,

(b)  $r=k\theta^2$ ,

(c)  $r=e^\theta$ ,

(d)  $r=10\sin\theta$ .

5. (a)-(d) Plot each curve in Ex. 4. Measure each desired length.

6. Like Ex. 9, p. 398, for  $r=20$  and a weight of .4 lb. per sq. ft.

7. Like Ex. 12, p. 398, for a radius of 8 ft. and a level 3 ft. above the top.

§ 296. **How to Plot a Surface.** To understand the calculation of volumes bounded by curved surfaces in general, we need to know how surfaces can be represented by equations.

Any plane curve is represented by some equation  $y=f(x)$ , which tells exactly how high the curve is above the  $X$ -axis at every point.

Similarly for a surface. We first select a horizontal reference plane, and in it choose  $X$  and  $Y$  axes. The height  $z$  of the surface above this plane will vary from point to point in some definite way. The surface will be definitely described, if we tell by an equation  $z=f(x, y)$  how high it is above every point  $(x, y)$  in the reference plane.

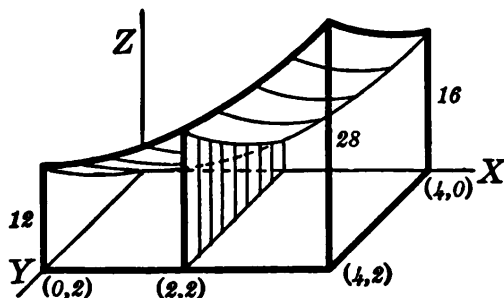

FIG. 140.

To plot a surface from its equation we proceed as in the following example.

Ex. I. Draw that part of the surface

$$z = x^2 + y^2 + 4y \quad (14)$$

which stands directly above a rectangle in the  $XY$ -plane bounded by the axes  $x=0$  and  $y=0$ , and the lines  $x=4$  and  $y=2$ .

First draw the specified base in perspective. (Fig. 140.) Its corners are the points  $(4, 2)$ ,  $(0, 2)$ ,  $(0, 0)$ ,  $(4, 0)$ .

Then calculate the height of the surface above each corner, and at various other points, using (14) :

$$x=4, y=2, \text{ give } z=16+4+8=28,$$

$$x=0, y=2, \text{ give } z=0+4+8=12; \text{ etc.}$$

Thus the height of the surface above the corners  $A(4, 2)$  and  $B(0, 2)$  is 28 units and 12 units, respectively. Similarly for the other values of  $z$  in the table.

$x$	$y$	$z$
0	0	0
0	1	5
0	2	12
2	0	4
2	1	9
2	2	16
4	0	16
4	1	21
4	2	28

Erect perpendiculars to represent the height of the surface above the base plane at these several points, and join the ends of the vertical lines by smooth curves. These are curves on the required surface, and show its general shape.

The surface forms a sort of tent-like roof over the space between it and the base plane.

**§ 297. Volumes by Double Integration.** Let us find the volume of the solid drawn in Fig. 140 above.

Consider a section perpendicular to the  $X$ -axis at any distance  $x$  from the origin. If we can express its area ( $A_x$ ) in terms of  $x$ , an integration will give the required volume. But as this section is not one of the figures of elementary geometry, we have no formula for its area, and must perform a *preliminary integration* to find its area.

Throughout this section,  $x$  has a constant value; but the height of the surface ( $z$ ) varies with  $y$ . The element of area in this section is, then,  $z dy$ ; \* and

$$\therefore A_x = \int_0^2 z dy = \int_0^2 (x^2 + y^2 + 4y) dy.$$

\* If this is not clear, make a rough drawing showing how the section would appear, if seen at right angles, looking into the *end* of the required volume.

Since  $x$  is a constant during this integration, we find (§ 88),

$$A_s = \left[ x^2 y + \frac{1}{3} y^3 + 2 y^2 \right]_0^{x^2} = 2 x^2 + \frac{32}{3}.$$

We now have the sectional area in terms of  $x$ , and can find the volume as in earlier cases :

$$V = \int_0^4 A_s dx = \int_0^4 \left( 2 x^2 + \frac{32}{3} \right) dx = \left[ \frac{2}{3} x^3 + \frac{32}{3} x \right]_0^4 = \frac{256}{3}.$$

This calculation would have been slightly modified, if the base of the solid, instead of being a rectangle, had been bounded, say, by the  $X$ -axis and the curve  $y = x^3$ , from  $x = 0$  to  $x = 2$ .

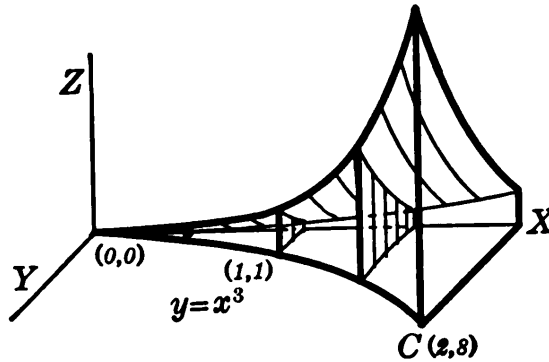

FIG. 141.

As above, we first draw the part of the  $XY$ -plane which is to be the base of the solid. (Fig. 141.)

The curve  $y = x^3$  need not be drawn accurately to scale for this purpose. But in calculating the height of the surface

$$z = x^2 + y^2 + 4 y$$

above any point on this curve, we must use the proper value

of  $y$  as well as  $x$  at that point, — the value of  $y$  being first found from the equation of the curve  $y = x^3$ . *E.g.*, at  $C$  (Fig. 141).

$$x = 2, y = 8; \therefore z = 100.$$

$A_s$  is again found by integrating  $z dy$ ; but the values between which  $y$  runs are not the same for all sections. The upper limit for  $y$  is a value depending upon the  $x$  of that section, viz., it is  $x^3$ . Hence \*

$$\begin{aligned} A_s &= \int_0^{x^3} z dy = \left[ x^2 y + \frac{1}{3} y^3 + 2 y^2 \right]_0^{x^3} \\ &= \frac{1}{3} x^9 + 2 x^6 + x^5. \\ V &= \int_0^2 A_s dx = \left[ \frac{1}{30} x^{10} + \frac{2}{7} x^7 + \frac{1}{6} x^6 \right]_0^2 = 81\frac{1}{3}. \end{aligned}$$

\* If it looks peculiar to have  $x^3$  as a limit of integration, remember that in this first integration  $x$  is a constant.



*Remark.* It is interesting to interpret this process from the standpoint of "infinitesimal elements." Consider a volume to be composed of tiny columns, of height  $z$  and bases  $dy dx$ . The whole volume is then the sum of these, or

$$V = \iint z dy dx.$$

Summing first with respect to  $y$  all columns having the same  $x$  gives a slice  $A dx$ . Summing these slices, as to  $x$ , gives  $V$ .

### EXERCISES

Draw that part of each of the following surfaces which stands over the specified portion of the  $XY$ -plane; and calculate the inclosed volume:

<i>Surface</i>	<i>Base</i>	
1. $z = x^2 + y^2,$	$y = 0$ to $3,$	$x = 1$ to $4.$
2. $z = x^2 + y^2,$	$y = 0$ to $y = x^2,$	$x = 0$ to $2.$
3. $z = xy,$	$y = 0$ to $y = x,$	$x = 1$ to $5.$
4. $z = xy,$	$y = 0$ to $y = \sqrt{x},$	$x = 0$ to $4.$
5. $z = x^2 + 6y,$	$y = 0$ to $y = x^2,$	$x = 0$ to $4.$
6. $z = 12x + y^2,$	$y = 1$ to $y = x,$	$x = 2$ to $x = 4.$
7. $z = xy + y^3,$	$y = 1$ to $y = \sqrt{x},$	$x = 1$ to $x = 4.$
8. $z = 4x + 5y,$	bounded by $X$ -axis and $y = 4x - x^2.$	

§ 298. **Special Plane Sections.** In studying the shape of a surface, it is helpful to know the nature of the cross-sections made by various planes. Sections perpendicular to an axis, — in which  $x$  or  $y$  is constant, — are the most easily studied.

Ex. I. What sort of curve is cut from the surface

$$z = x^2 + y^4 + 10$$

by the plane  $y = 2$ ? What is its slope at any point?

Putting  $y = 2$  makes  $z = x^2 + 26$ . (Here  $z$  is the height of the curve and  $x$  the horizontal distance.) The section is therefore a parabola, extending in the positive  $Z$  direction, and

raised 26 units. Differentiating gives  $dz/dx = 2x$ , the slope at any point.

This slope could be found directly from the equation of the surface by simply *treating  $y$  as constant* while differentiating. Similarly, in any section perpendicular to the  $X$ -axis,  $x$  would be a constant; and the slope would be  $dz/dy = 4y^3$ . (In such a section  $y$  would be the horizontal coördinate and  $z$  the vertical.)

**§ 299. Partial Derivatives.** Whenever, as in § 298, we differentiate a function  $z = f(x, y)$ , treating  $y$  as a constant, we are said to find the “partial derivative” of  $z$  with respect to  $x$ , written  $\partial z/\partial x$ . Similarly for  $\partial z/\partial y$ .

Thus in the case  $z = x^2 + y^4 + 10$  above,

$$\frac{\partial z}{\partial x} = 2x, \qquad \frac{\partial z}{\partial y} = 4y^3.$$

Similarly, if  $z = x^6 + 5x^2y^3 + 8y^2$ ,

$$\frac{\partial z}{\partial x} = 6x^5 + 10xy^3, \qquad \frac{\partial z}{\partial y} = 15x^2y^2 + 16y.$$

*Geometrically* interpreted:  $\partial z/\partial x$  is the slope of a section of the surface  $z = f(x, y)$  made by a plane  $y = c$ . *Physically*, it is the rate at which  $z$  changes per unit change in  $x$ , if  $y$  remains constant.

In general, if  $z$  is a function of several variables  $x, y, u, v, \dots$ , then  $\partial z/\partial x$  will give the rate at which  $z$  will change with  $x$ , while  $y, u, v, \dots$ , remain fixed, — or, as we say in daily life: “Other things being equal.”

**§ 300. Extreme Values.** It is sometimes necessary to find the maximum value of a function of two variables which can change independently of each other, say  $z = f(x, y)$ .

This amounts to finding the highest point on a surface,  $z = f(x, y)$ . Such a point must be the highest on each of the two special sections ( $x = c_1, y = c_2$ ) passing through it. Hence,

unless the surface rises sharply to the point, the slope of each section must be zero :

$$\frac{\partial z}{\partial x} = 0, \qquad \frac{\partial z}{\partial y} = 0. \qquad (15)$$

And similarly for a minimum.

More generally, let  $z$  be a function of several variables,  $z = f(x, y, u, \dots)$ . Its maximum value must be the greatest obtainable by varying  $x$  and keeping  $y, u, \dots$  constant. Hence  $\partial z / \partial x = 0$ . Similarly  $\partial z / \partial y = 0$ , etc.

Ex. I. Test  $z = x^2 - 6x + y^2 - 4y + 30$ .

$$\frac{\partial z}{\partial x} = 2x - 6 = 0, \qquad \frac{\partial z}{\partial y} = 2y - 4 = 0.$$

This gives  $x = 3, y = 2$ , whence  $z = 17$ .

Testing each derivative on both sides shows this point to be the lowest on each sectional curve. This suggests that it is the lowest point on the surface; but is not a sure test, since the surface might go lower somewhere between the sections. Systematic methods of making sure tests are discussed in more advanced courses.

### EXERCISES

1. Plot and find the volume under the surface  $z = x^3 + y^3$  from  $y = 0$  to  $y = x^2$  and from  $x = 0$  to  $x = 2$ .

2. In Ex. 1 what sort of section is made by the plane  $x = 2$ ? Find its slope at the point where  $y = 3$ .

3. What is the character of the sections of each of the following surfaces made by the specified planes, and what is the slope of each section at their common point?

<i>Surface</i>	<i>Cutting Planes</i>	
(a) $z = x^2 + 4y + 5$ ,	$x = 2$ ,	$y = 1$ .
(b) $z = 100 - x^2 - y^2$ ,	$x = 8$ ,	$y = 6$ .
(c) $z = xy$ ,	$x = 5$ ,	$y = 10$ .
(d) $z = 6x - 3y$ ,	$x = 3$ ,	$y = 0$ .

4. (a)-(e). The same as Ex. 3 for the surfaces in Ex. 1, 4, 5, 6, 8, p. 405, and the cutting planes  $x = 2, y = 1$ .

5. In Ex. 3 (b) find the maximum  $z$ . Also test Ex. 3 (a).

6. Locate any possible maxima and minima for the following functions, and make a sure test if you can :

$$(a) z = x^2 + 4y^2 - 6x + 8y + 30, \quad (b) z = 40 - x^4 - y^2,$$

$$(c) z = x^3 + 3y^2 - 6y + 20, \quad (d) z = 10x^2 + 12y^2 - x^4 - y^4.$$

7. The temperature at any point  $(x, y)$  of a square metal plate varied thus :  $T = x^2 + y^2 - 12x - 10y + 300$ . Where was the coolest point?

§ 301. **The Mean Value Problem Resumed.** We saw in § 96 that the work done by a variable force  $F$  in moving an object any distance, say from  $x = a$  to  $x = b$ , is

$$W = \int_a^b F dx.$$

The average force acting during that distance is by definition the total work divided by the distance ; *i.e.*,

$$\bar{F} = \frac{\int_a^b F dx}{b - a}. \quad (16)$$

Let us compare this definition of average force with the usual idea of an average as a value obtained by averaging up a number of distinct values.

Consider the actual average of  $n$  values of the force  $F$  selected at equal intervals of distance,  $\Delta x$ , from  $x = a$  to  $x = b$  :

$$\text{av. of } n \text{ values} = \frac{F_1 + F_2 \cdots + F_n}{n}.$$

The larger we take  $n$ , the nearer this will come to what we would call the average of *all* the force-values between  $a$  and  $b$ .

To see what the limiting value is, which this approaches, multiply numerator and denominator by  $\Delta x$  :

$$\text{av. of } n \text{ values} = \frac{F_1 \Delta x + F_2 \Delta x \cdots + F_n \Delta x}{n \Delta x}.$$

Now as  $n$  becomes indefinitely great,  $\Delta x \rightarrow 0$ , and by the Fundamental Theorem of § 291, the limiting value of the numera-

tor is  $\int_a^b F dx$ . The denominator  $n\Delta x$  is simply the whole distance from  $x=a$  to  $x=b$ , *i.e.*,  $(b-a)$ . Hence we consider the average of *all* the force-values between  $a$  and  $b$  to be

$$\bar{F} = \frac{\int_a^b F dx}{b-a},$$

the same value as that obtained in (16).

Evidently the same argument would lead to the following definition of the average value of any varying quantity  $y=f(x)$  from  $x=a$  to  $x=b$ :

$$\bar{y} = \frac{\int_a^b y dx}{b-a}. \quad (17)$$

Geometrically interpreted, the numerator of (17) is the area under the curve  $y=f(x)$ . So that the average height  $\bar{y}$  is simply the area divided by the length of base considered, — agreeing with our definition of *mean ordinate* in § 13.

Ex. I. If  $y=x^2$ , find the average value of  $y$  between  $x=1$  and  $x=5$ .

Here

$$\bar{y} = \frac{\int_1^5 x^2 dx}{5-1} = \frac{\frac{1}{3}[5^3-1^3]}{4} = \frac{31}{3}.$$

**§ 302. Simpson's Rule.** Many of the quantities considered in the natural and social sciences are representable by the area under some graph, and can be approximated by measuring that area. It is desirable, however, to be able to approximate such an area without plotting and without integrating.

The problem is virtually to find the *average height* of the graph, which, multiplied by the base, would give the area.

The following rule, devised about 1750 by Thomas Simpson, an Englishman, gives excellent results for many curves:

The average height  $y$  from  $x = a$  to  $x = b$  is found by averaging the heights at  $a$  and  $b$  with four times the height at the middle :

$$y = (y_a + y_b + 4 y_m) \div 6. \quad (18)$$

And the area under the graph is this  $\bar{y}$  times the base  $(b - a)$  :

$$A = \frac{1}{6} (y_a + y_b + 4 y_m) \cdot (b - a). \quad (19)$$

Ex. I. Find the area under the parabola  $y = x^2$  from  $x = 2$  to  $x = 10$ .

The first height, at  $x = 2$ , is  $y = 4$ . The final height, at  $x = 10$ , is  $y = 100$ . The middle height, at  $x = 6$ , is  $y = 36$ . Hence by (18) :

$$\bar{y} = [4 + 100 + 4(36)] \div 6 = 41\frac{1}{3}.$$

Multiplying  $\bar{y}$  by the base, from  $x = 2$  to 10, gives the area :  $A = 330\frac{2}{3}$ .

Remarks. (I) In this case we can check by integration :

$$A = \int_2^{10} y \, dx = \int_2^{10} x^2 \, dx = \frac{1}{3} (992) = 330\frac{2}{3}.$$

But the rule is most useful when integration is impracticable.

(II) The rule gives exact results whenever the formula for the height of the graph is of the first, second, or third degree. (This is proved in the Appendix, p. 490.) Generally it gives only an approximation, — but a close one if the interval is small. A large interval may be split into smaller sub-intervals, and the rule applied to each. In fact, Simpson's rule is usually stated in a more general form than (19), giving the total result for  $n$  intervals.

**§ 303. General Applicability.** Any definite integral, whatever its original physical meaning, can be thought of as the area under some curve, and hence can be approximated by Simpson's Rule.

*E.g.*, suppose the work done by a force was to be found from

$$W = \int_1^5 \sqrt{1+x^2} \, dx.$$

This same integral would give the area under the curve  $y = \sqrt{1+x^2}$  from  $x = 1$  to 5. So to approximate the integral we would simply calculate the value of  $\sqrt{1+x^2}$  at 1, 3, and 5, average according to the rule, and multiply by the length of the interval, 4.

In general, we would proceed similarly with any function  $f(x)$  to be integrated, — getting its values at the beginning, middle, and end, etc. Thus, approximately,

$$\int_a^b f(x) dx = \frac{1}{3}[f(a) + f(b) + 4f(x_m)](b-a), \quad (20)$$

where  $x_m$  is the value of  $x$  midway between  $a$  and  $b$ .

### EXERCISES

1. Find the approximate area under a curve from  $x=10$  to  $x=20$  if the height of the curve is 8 at  $x=10$ , 12 at  $x=15$ , and 6 at  $x=20$ .

2. Find by Simpson's Rule the area under  $y=x^2$  from  $x=3$  to 5. Check by integration. What is the average height?

3. The same as Ex. 2 for the curve  $y=x^3$  from  $x=2$  to 6.

4. How much error is there in the area under  $y=1/x$  from  $x=1$  to 5, as given by Simpson's Rule without subdividing?

5. What area problem would call for the calculation of the integral,  $\int_4^{16} \sqrt{x} dx$ ? How accurately does Simpson's Rule give this area?

6. Find by Simpson's Rule the integrals:

$$(a) \int_1^9 \sqrt{x} dx, \quad (b) \int_0^8 (x^2 + 6x + 1) dx, \quad (c) \int_0^{\pi/4} \cos x dx.$$

7. Express as a definite integral, and then approximate by (20):

(a) The work done from  $x=2$  to  $x=6$  by a force varying thus:  $F = .2x^2$ . (Check.)

(b) The volume from  $x=0$  to  $x=4$  of a solid whose cross-section area varies thus:  $A = \sqrt{x^2 + 1}$ .

8. Find the exact mean value of each of the following:

- (a) Of  $x^5$  from  $x=0$  to  $x=4$ ; (b) Of  $1/x^2$  from  $x=1$  to 3;  
 (c) Of  $\sqrt{x^3}$  from  $x=0$  to  $x=4$ ; (d) Of  $\sin x$  from  $x=0$  to  $\pi/2$ .

9. For an electric current:  $i = 20 \sin 400t$ . Find the mean current flowing during a half-period.

10. For a pendulum:  $\omega = .2 \cos \pi t$ . Find the mean angular velocity,  $\bar{\omega}$ , during an upward swing.

§ 304. **Prismoid Formula.** Applied to volumes, Simpson's rule may be stated in a simple form, called the Prismoid Formula.

The volume of a solid between two parallel planes is

$$V = \int_a^b A \, dx. \quad (\S 97)$$

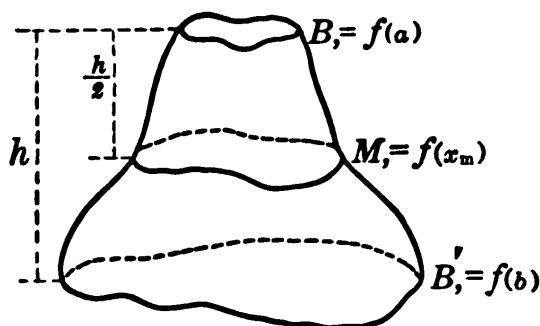

FIG. 142.

The values of the area-function  $A$  at the beginning and end are simply the areas of the bases  $B$  and  $B'$ . (Fig. 142.)

$$\therefore V = \frac{1}{8} [B + B' + 4M] \cdot h,$$

where  $M$  is the area midway between bases, and  $h$  (or

$b - a$ ) is the height. That is, *the volume of a solid equals its height times the average cross-section area, found by averaging the bases with four times the mid-section.*

Ex. I. A uniformly tapering timber 20 ft. tall has square bases  $2 \times 2$  and  $8 \times 8$  inches. Find its volume.

The mid-section is a square,  $5 \times 5$ . Hence

$$B = 4, \quad B' = 64, \quad M = 25, \quad h = 20(12) = 240.$$

$$\therefore V = \frac{1}{8}(4 + 64 + 100)240 = 6720.$$

This value is exact. For the cross-section area varies as the *square* of the distance  $x$  from a certain point. (What point?)

### EXERCISES

1. Find by the Prismoid Formula the volume of a cone of height 12 in. and base radius 4 in. Check by geometry.
2. The same as Ex. 1 for a sphere of radius 20 in.
3. A uniformly tapering timber 30 ft. long has ends 1 ft. square and 2 ft. square. Find its volume.
4. Find the approximate volume of a barrel 30 in. long with a radius of 12 in. at each end and 15 in. at the middle, — inside dimensions.
5. A solid has three mutually perpendicular elliptic cross-sections, with semi-axes of 12 in., 10 in., and 8 in. Find its volume.
6. The frustum of a cone is 18 in. tall and has base radii of 4 in. and 8 in. Find its volume.



7. The base of a granite column is 3 ft. high and has a radius of 2 ft. at the top, 3 ft. at the middle, and 5 ft. at the bottom. Find its approximate volume.

8. Every horizontal section of a certain solid  $z$  in. above the lowest point is an ellipse:  $x^2/36z + y^2/16z = 1$ . (What axes have the sections at  $z=10, 1, 0$ ?) Draw the solid from  $z=0$  to  $z=10$ . Also find its volume by integration, and by the Prismoid Formula.

9. A sphere of radius 10 in. is cut by two parallel planes 6 in. and 8 in. from the center, on the same side. Find the included volume by the Prismoid Formula.

10. Find the volume in Ex. 9 by integration.

§ 305. Summary of Chapter XII. Any quantity expressible as the limit of a sum, of a certain form (§ 291), is equal to a certain definite integral, *i.e.*, the difference of two values of an indefinite integral.

*E.g.*, the area under a curve  $y=f(x)$  from  $x=a$  to  $x=b$  is

$$A = \lim_{\Delta x \rightarrow 0} [y_1\Delta x + \dots + y_n\Delta x] = \int_a^b y dx,$$

*i.e.*,  $A = F(b) - F(a)$ ,

where  $F$  is the integral function, whose derivative equals  $y$  or  $f(x)$ . Further cases are listed in the Appendix, p. 498.

Originally, a definite integral was regarded as the sum of numerous infinitesimal elements. But the formulas then used in "summing" did not give the sum. They were the same as our formulas for integrating, and thus gave the *limit* of the sum, — the value really required.

In finding the volume of a solid two successive integrations may be required: one to find the area of a cross-section, and the other to get the volume itself.

To show graphically how a quantity  $z$  varies with *two* other quantities  $x$  and  $y$  on which it depends, we must draw a *surface*. The variation of  $z$  with  $x$  or  $y$  alone is shown by a *section* of the surface perpendicular to the  $Y$  or  $X$  axis. The rate of change is then  $\partial z/\partial x$  or  $\partial z/\partial y$ .

The mean value of a function is conveniently defined in terms of definite integrals. Its value may often be approximated by Simpson's Rule.

### EXERCISES

(Integrals may be found from the Table, p. 494, if necessary.)

1. Find the area bounded by the curve  $y^2 = x^3$ , the  $X$ -axis, and the ordinate at  $x = 5$ .
2. Find the length of the curved arc considered in Ex. 1.
3. Find the area bounded by the  $X$ -axis and the curve  $y = 1 - x^2$ . (What kind of curve is this, and how located?)
4. Find the volume under the surface  $z = xy$ , above the part of the  $XY$ -plane from  $y = 0$  to  $y = x^2$  and from  $x = 0$  to  $x = 2$ . Plot.
5. Find the volume from  $z = 0$  to  $z = 3$  of a solid whose every horizontal section is an ellipse, with one of these equations:

$$(a) \frac{x^2}{100z} + \frac{y^2}{64z} = 1, \quad (b) \frac{x^2}{100(1+z^2)} + \frac{y^2}{36(1+z^2)} = 1.$$

6. The thickness ( $T$  in.) of certain pavement  $x$  ft. from the middle line is:  $T = 3 + .003x^2$ . Find the average thickness,  $x = 0$  to  $x = 10$ .
7. In Ex. 7, p. 398, change the length of the beam to 20 ft., and let the load vary thus:  $L = 6x$ . Find the total moment.
8. In Ex. 10, p. 398, change the radius to 20 in., and let  $w$  vary thus:  $w = 6 - .4x$ . Find the total weight.
9. Find by Simpson's Rule the area under the curve  $y = \sin x$  from 0 to  $\pi/2$ , — cutting this into three parts. Compare the exact value.
10. If a circle of radius 10 in. be revolved about a line 12 in. from its center, what sort of surface will be generated? What sort of section will be made by any plane perpendicular to the axis of rotation? Find the volume.
11. A tunnel has a level floor 12 ft. wide and arched walls forming a parabola with the vertex 16 ft. high. If it is full of water, what will be the pressure against a vertical end of the tunnel?
12. The capstone of a monument has square horizontal sections, whose vertices all lie on two vertical semicircles of radius 3 ft. Find the volume of the cap, if 2 ft. high.
13. In a certain type of tank the weight of steel used in the wall varies thus with the diameter  $x$  and height  $y$ :  $W = .01x^2y^2$ . Plot a surface showing this variation, from  $x = 20$  to 100 and  $y = 0$  to 10.

## CHAPTER XIII

### PROGRESSIONS AND SERIES

#### INVESTMENT THEORY — CALCULATION OF FUNCTIONS

§ 306. **Problems to be Considered.** We have now defined and studied briefly the following kinds of functions: logarithmic, exponential, trigonometric and power functions, derivatives and integrals. To round out our knowledge of these various functions, — as far as practicable in an introductory course, — we shall now consider a very general method of finding their values, by which we can calculate tables and discover relations among the different functions.

As a preliminary, however, we must recall certain formulas of elementary algebra. Incidentally we shall see how the fundamental problems of the Theory of Investment are solved.\*

§ 307. **Arithmetical Progressions.** A series of numbers like

$$3, \quad 7, \quad 11, \quad 15, \quad 19, \quad \text{etc.},$$

which have a constant difference is called an Arithmetical Progression, — abbreviated as *A. P.*

If  $a$  denotes the first term and  $d$  the constant difference, any *A. P.* may be written

$$a, \quad a+d, \quad a+2d, \quad a+3d, \quad \dots$$

\* In business such problems are usually solved by merely consulting tables of interest, discount, annuities, etc. But our methods will handle cases not covered by the tables (cf. Ex. 2, p. 439 and Ex. 18, p. 482), and will show also how the standard tables were first obtained.

The fourth term is  $a+3d$ . What would the 10th be? The 17th?

If there are  $n$  terms in all, the last one is evidently

$$l = a + (n-1)d. \quad (1)$$

A formula for the *sum* of all the terms is easily found. Write the terms in the order above and also reversed :

$$\begin{aligned} S &= a + (a+d) + (a+2d) \cdots + (l-d) + l, \\ S &= l + (l-d) + (l-2d) \cdots + (a+d) + a. \end{aligned}$$

Add, and observe that each sum on the right reduces to  $(a+l)$  :

$$\therefore 2S = (a+l) + (a+l) \cdots + (a+l) = n(a+l).$$

$$\therefore S = \frac{n}{2}(a+l). \quad (2)$$

This formula has a simple interpretation which makes it easy to remember: The average value of the terms is  $\frac{1}{2}(a+l)$ , and the sum equals this average value multiplied by the number of terms.

Ex. I. Find the last term and sum of the *A. P.*, 2, 5, 8, 11, . . . to 20 terms.

Here  $a=2$ ,  $d=3$ ,  $n=20$ .

$$\therefore l = 2 + 19(3) = 59, \quad S = \frac{20}{2}(2+59) = 610.$$

Ex. II. A debt is to be paid off in 30 payments running as follows: \$200, \$195, \$190, etc. Find the total amount to be paid.

The payments form an *A. P.* with  $a=200$ ,  $d=-5$ ,  $n=30$ . Hence the last term is  $l=200+29(-5)=55$ ; and

$$S = \frac{30}{2}(200+55) = 3825.$$

§ 308. **Geometrical Progressions.** A series of numbers like

$$2, \quad 6, \quad 18, \quad 54, \quad 162, \quad \text{etc.},$$

each of which equals the preceding multiplied by some constant, is called a Geometrical Progression, — abbreviated *G. P.*

If  $a$  denotes the first term of a *G. P.*, and  $r$  the constant multiplier or *ratio*, the progression may be written :

$$a, \quad ar, \quad ar^2, \quad ar^3, \quad \dots$$

Here the 4th term is  $ar^3$ . What would the 10th term be? The 17th?

If there are  $n$  terms in all the last one is evidently

$$l = ar^{n-1}. \quad (3)$$

A formula for the sum of all the terms,

$$S = a + ar + ar^2 + \dots + ar^{n-1}$$

is easily found. Multiplying by  $r$  and subtracting  $S$  from  $rS$  gives

$$\begin{aligned} rS &= ar + ar^2 + \dots + ar^{n-1} + ar^n. \\ \therefore rS - S &= -a + ar^n. \end{aligned}$$

Factoring both sides and solving for  $S$ , we have

$$S = \frac{a(r^n - 1)}{r - 1}. \quad (4)$$

**Ex. I.** Find the last term and the sum of the *G. P.*, 2, 6, 18, etc., to 20 terms:

Here  $a = 2$ ,  $r = 3$ ,  $n = 20$ , whence  $l = 2(3)^{19}$  and

$$S = \frac{2(3^{20} - 1)}{3 - 1} = 3^{20} - 1.$$

Approximate values of  $l$  and  $S$  can be found quickly by using logarithms.

### EXERCISES

1. What is the charge for ten postage stamps, one of each denomination from 1¢ to 10¢? Check by addition.

2. Find the sum of the first 30 odd integers. Of all odd integers < 100.

3. Find the sum of the first 20 even integers. Of all even integers < 175.

4. Find the sum of all integers between 100 and 800 which end in 3. Of all integers between 1 and 999 which are divisible by 5.

5. 500 raffle tickets are sold, at all prices from 1¢ to \$5.00. What are the total receipts?

6. In a contest there are to be 12 prizes: \$500, \$475, \$450, etc. What will the total amount be? Check.

7. If we make 10 monthly deposits of \$60 each, beginning now, and are allowed simple interest at 4%, how much will there be to our credit one year hence?

8. In the *G. P.*, 8, 12, 18, . . ., what are  $a$  and  $r$ ? Express by a formula the 12th term; also the sum of 30 terms.

9. The same as Ex. 8 for the *G. P.*, 900, 600, 400, . . .

10. Each stroke of a pump removes one fourth of the air remaining in a vessel. What fraction of the original weight will remain after 20 strokes?

11. In the *G. P.*, 3, 6, 12, . . ., find by formula the 10th term and the sum of the first 6 terms. Check by direct calculation.

12. In the *G. P.*,  $100(1.06)^6$ ,  $100(1.06)^8$ , . . .,  $100(1.06)^{20}$ , what are  $a$ ,  $r$ , and  $n$ ? Find the sum.

13. If we make 10 annual deposits of \$500 each, beginning now, and these draw interest at  $3\frac{1}{2}\%$ , compounded annually, how much will there be to our credit 30 years hence? (Before trying to sum up, express the amount accumulated by the 1st deposit, 2d deposit, and last deposit.)

14. A present debt of \$600 on a piano is to be paid in monthly installments of \$30, plus accrued interest at 8%. How much will the first payment be, 1 mo. hence? The last payment? The total amount paid?

15. The same as Ex. 14 for a debt of \$1000 on an automobile, to be paid off in monthly installments of \$100 with 6% interest.

16. A sewer assessment of \$225 is payable \$22.50 per year, beginning now, plus interest at 6%. How much will be paid in all?

17. The problem of dividing an octave into 12 equal semitones is mathematically the same as the problem of inserting 11 "geometric means" between 1 and 2, — *i.e.*, 1 and 2 are to be the first and last terms of a *G. P.* of 13 terms. Find the third and seventh terms.

18. Carry out in detail the derivation of formula (4), as given in § 308, in a special case, say  $n=7$ , writing out all the terms. Then check by dividing out  $(r^7-1) \div (r-1)$  and getting the original *G.P.*

**§ 309. Investment Problems : Accumulation.** In business it is often necessary to find how large a fund will be accumulated at a specified date by making certain deposits or payments at stated intervals. Or, conversely, how large the payments must be to yield a certain sum finally.

To solve such problems, simply express the amount accumulated on each payment at the end of the time, using the interest formula :

$$A = P \left( 1 + \frac{r}{k} \right)^{kn} .$$

Then sum up. This is quickly done when the amounts form a *G. P.*

Ex. I. If we make 20 annual deposits of \$100 beginning now, and are allowed 4% interest compounded annually, how much will there be to our credit 30 years hence?

- 1st deposit, with 30 yrs.' int. will amount to  $100(1.04)^{30}$
- 2nd deposit, with 29 yrs.' int. will amount to  $100(1.04)^{29}$
- . . . . .
- 20th deposit, with 11 yrs.' int. will amount to  $100(1.04)^{11}$

The 20th deposit, being made at the beginning of the 20th year, or 19 years hence, and running until 30 years from now, will be at interest for 11 years.

These amounts form a *G. P.* For, starting from the bottom, if we multiply any of them by 1.04, we obtain the next above.

$$\therefore a = 100(1.04)^{11}, \quad r = 1.04, \quad n = 20.$$

The total amount to our credit 30 years hence will be the sum :

$$S = \frac{100(1.04)^{11}[(1.04)^{20} - 1]}{1.04 - 1}, = 4584.20.*$$

*Remarks.* (I) In calculating *S* by logarithms, we must go from the logarithm of  $1.04^{20}$  back to the number before subtracting the 1. The denominator, .04, may be canceled into the 100 to save work.

(II) The amounts above also form a *G. P.* starting from the top. But then the constant multiplier *r* is  $\frac{1}{1.04}$ , which is inconvenient.

(III) In the *G.P.* formula *n* denotes the *number of terms* to be added, *i.e.*, the number of *payments*, — not some number of years. Also *r* denotes the *ratio for the G. P.*, — not the interest rate.

Before trying to sum, always write out a few terms of the *G.P.*, to recognize *a* and *r*; and be especially careful as to the time that each payment draws interest. *The number of years elapsing between the first and last payment is one less than the number of payments.*

\* Five-place tables will not give this very accurately.

§ 310. **Life Insurance.** To determine what "annual premium" to charge for insuring a man's life, an insurance company must ascertain what sum, invested annually at a certain estimated rate of interest, *would yield the amount of policy* at the expected time of death. (It is known from Tables of Mortality that an average group of men at the age of the insured have a certain number of years to live.)

The company plays safe by insuring no one whose health is poor, and by figuring interest at a lower rate than is actually earned. The premium charged is thus larger than necessary; and the excess charge is returned annually as a "dividend." The annual premium, by the way, includes a charge to cover administrative expenses. But we seek here only the "net premium" which goes to provide the face of the policy.

Ex. I. Fifteen annual premiums of \$ $P$  each, beginning now, are to provide a \$10,000 policy 40 years hence. Find  $P$ , figuring interest at  $3\frac{1}{2}\%$ .

The last premium payable 14 years hence will draw interest 26 years.

1st premium, with 40 yrs.' int., will yield  $P (1.035)^{40}$

2d premium, with 39 yrs.' int., will yield  $P (1.035)^{39}$

.....  
last premium, with 26 yrs.' int., will yield  $P (1.035)^{26}$

These amounts, starting from the bottom, form a  $G. P.$  in which

$$a = P (1.035)^{26}, \quad r = 1.035, \quad n = 15.$$

The sum of these accumulated amounts must be \$10,000:

$$S = \frac{P(1.035)^{26}[1.035^{15} - 1]}{1.035 - 1} = 10000.$$

$$\therefore P = \frac{350}{1.035^{26}[1.035^{15} - 1]}$$

By logarithms we find  $P = 211.89$ , — the net annual premium.\*

\* In actual practice premiums are not calculated in this way. It is necessary to figure on the cost of a large group of policies rather than a single "average" policy. The actual procedure is explained in treatises on life insurance.



## EXERCISES

*Here and in what follows all interest is to be compounded annually unless otherwise specified.*

1. Twenty annual deposits of \$600 each are to be made beginning now. With 4% interest, what will the total accumulation be 25 years hence?

2. What sum deposited now at 4% would yield the same final amount as in Ex. 1?

3. How much should a firm set aside annually beginning one year hence and ending 30 years hence to replace a \$100,000 building at the time of the last deposit if interest is at  $4\frac{1}{2}\%$ ?

4. When a boy was 1 year old, his father began depositing \$50 a year in a bank which paid 4% interest, compounded semiannually. What sum had been accumulated when the boy reached the age of 17? (Include the final \$50.)

5. A city has just issued bonds for \$500,000 to construct an auditorium. What sum raised annually by taxation, beginning 1 year hence, and set aside at 6% interest, will meet the face of the bonds when they mature 10 years hence?

6. A bridge costing \$35,000 must be replaced every 20 years. What sum set aside annually for 10 years, beginning 1 year after the construction of the bridge and drawing 5% interest compounded quarterly, would yield enough for the first renewal?

7. In a certain society the annual dues are \$5, payable in advance. A life membership costs \$50. If a member lives 15 years after joining, which arrangement would have been the more economical, figuring interest at 6% on any dues paid in either way?

8. What net annual premium, payable at the beginning of each year, would provide for a life insurance policy of \$1000, 38 years hence, if the company earns 5% net?

9. As in Ex. 8, find the premium in each of the following cases:

<i>Time to run</i>	<i>Interest Rate</i>	<i>Face of Policy</i>
(a) 40 yrs.	5.2%	\$ 2,000
(b) 35 yrs.	6%	\$ 1,000
(c) 35 yrs.	3%	\$ 1,000
(d) 42 yrs.	4.8%	\$10,000
(e) 25 yrs.	4.5%	\$ 1,000

10. A balance of \$1125.60 owing on a mortgage Sept. 1, 1916, was paid in monthly installments of \$37.50, including accrued interest at

7% and beginning Oct. 1, 1916. How much was still due after the payment of Jan. 1, 1919? (Figure two separate funds: the amount which would have been due if nothing had been paid; and the amount which would have been accumulated by the payments if not applied on the debt. Subtract.)

**§ 311. Present Value.** Money payable at some future date is not worth the same amount now. Its "present value" is only so much as would have to be invested now (at the prevailing rate of interest), to yield the specified payment at the time when due.

*E.g.*, if money will now earn 6%, compounded annually, the present value of \$1000 payable 10 years hence is only \$558.40. For calculations show that \$558.40 invested now at 6% would yield \$1000 in 10 years.

A formula for the present value of any amount  $A$ , payable  $n$  years hence, is obtained immediately from the interest formula:

$$A = P \left( 1 + \frac{r}{k} \right)^{kn}.$$

$$\therefore P = \frac{A}{\left( 1 + \frac{r}{k} \right)^{kn}}. \quad (5)$$

For the present value is simply the principal which will yield  $A$ . This " $P. V.$ " formula is useful in many investment problems.

Observe that, the more remote the payment of a sum, the smaller its  $P. V.$  Thus the  $P. V.$  of \$1000 after various intervals ( $n$  years) decreases approximately as in the adjacent table, — if interest is at 6%, compounded annually.

$n$	$P. V.$
0	1000
5	747
10	558
15	417
20	312

**§ 312. Investment Problems: Disbursement.** A very common problem in business is this: To determine how large a sum would have to be deposited now to provide for



The sum is the total present value of all the payments and should equal the present debt, viz., \$2000. Or since

$$a = \frac{A}{(1.0067)^{62}}, \quad r = 1.0067, \quad n = 60,$$

$$\therefore S = \frac{A}{(1.0067)^{62}} \frac{(1.0067^{60} - 1)}{.0066667} = 2000.$$

$$\therefore A = \frac{2000(.0066667)(1.0067)^{62}}{1.0067^{60} - 1}.$$

By logarithms,  $A = 41.09$ , — the monthly installment.

Observe that to round off the factor .0066667 as .0067 would produce a considerable error in  $A$ . But to round off 1.0066667 as 1.0067 does not.

Observe, too, that we have not credited against the *present debt* of \$2000 the full amount (\$ $A$  each) of the coming payments, but only the *present values* of those payments. The total of the sixty installments is  $60A$ , or \$2465.40; so that the debtor pays interest amounting in all to \$465.40.

### EXERCISES

1. Find the present value of \$15,000 payable 20 years hence, if interest is at  $3\frac{1}{2}\%$ , compounded semiannually.

2. Verify the third and the last values shown in the table of  $P.V.$ 's on page 432.

3. How much, deposited to-day, would provide for 20 annual payments of \$800 beginning 25 years hence, if interest is at  $4\frac{1}{2}\%$ ?

4. The same as Ex. 3, for 10 annual installments of \$600 beginning 10 yr. hence, if interest is at  $4\%$ .

5. If we invest \$10,000 now at  $6\%$ , how much can we get back each year, 20 times, beginning 15 years hence?

6. A balance of \$2500 now due on a house is to be paid off in 50 monthly installments beginning one month hence, with interest at  $8\%$ . Find the installment.

7. The same as Ex. 6, for a balance of \$2000 to be paid in 40 monthly installments beginning 3 months hence, with interest at  $6\%$ .

8. How much deposited now would yield forty quarterly installments of \$300 each, beginning 10 years hence, if interest is at  $4\%$ , compounded quarterly?

9. Express by a formula the amount of the installment if:

(a) A balance of \$500 on an auto is to be paid off in 8 monthly installments beginning one month hence, with interest at  $6\%$ .

(b) A balance of \$3500 on a house is to be paid off in 9 annual installments beginning one year hence, with interest at 8%.

(c) An Insurance Company which earns 5% is to make 60 quarterly payments beginning now, in lieu of paying \$10,000 now.

10. (a)–(c). Calculate the values of the installments in Ex. 9, (a)–(c).

11. How expensive a house can be purchased by paying \$1500 down, plus 96 monthly installments of \$60 each, if interest is at 6%, computed monthly?

12. A bond calls for the payment of \$1000 ten years hence. If money is worth 4%, compounded semiannually, what is the present value of the future payment?

§ 313. **Valuation of Bonds.** When a corporation or a government issues a bond, it promises to pay on a certain date the sum specified in the bond, and meanwhile to pay at stated intervals a certain amount of interest.

The *market value* of a bond, prior to the date of maturity, is usually different from the *face value*, — due to the fact that the rate of interest prevailing in the money market rarely happens to be the same as the rate named in the bond.\*

Normally, the market value of a bond is simply the sum of the present value of the principal payable at maturity, plus the present values of the several interest payments to be made on specified dates.

Ex. I. A \$1000 Liberty Bond maturing 10 years hence carries interest at  $4\frac{1}{4}\%$ , payable semiannually. Calculate its present value, assuming money now worth 5%, compounded semiannually.

The government is to pay \$1000 ten years hence; and also pay \$21.25 interest every half-year, beginning 6 months hence, until maturity. The *P. V.*'s of the 20 interest payments, with money now at 5%, are

$$\frac{21.25}{(1.025)^1}, \quad \frac{21.25}{(1.025)^2}, \quad \dots, \quad \frac{21.25}{(1.025)^{20}}$$

\* The value is affected also by the nature of the security, privileges of conversion or tax-exemption, etc., — factors which cannot be discussed here.

or in all :

$$S = \frac{21.25}{(1.025)^{20}} \frac{(1.025^{20} - 1)}{.025} = 331.27.$$

The present value of the principal, \$1000, payable ten years hence, is

$$P = \frac{1000}{(1.025)^{20}} = 610.27.$$

The total,  $S + P = 941.54$ , should be the present price of the bond.

*N.B.* The rate of interest named in the bond merely fixes the amount of the interest installments. All present values are determined by *the rate which money is now worth.*

Observe, too, that the government will pay on the bond \$1000 + 20(21.25), or \$1425 in all, but the *P. V.* of these payments now is only \$941.54.

### EXERCISES

1. A \$1000 bond maturing 20 years hence carries  $4\frac{1}{2}\%$  interest, payable semiannually. If money is now worth  $5\%$ , compounded semiannually, what is the present value of the bond?

2. Express by formulas the present values of the following bonds :

Description of Bond	Maturity	Market Int.
(a) \$1000, $4\frac{1}{2}\%$ , semi.	15 yrs. hence	$6\%$ , semi.
(b) \$500, $5\%$ , quart.	20 yrs. hence	$4.8\%$ , quart.
(c) \$5000, $4\frac{1}{2}\%$ , semi.	10 yrs. hence	$5\%$ , semi.
(d) \$10,000, $6\%$ , quart.	8 yrs. hence	$5.8\%$ , quart.
(e) \$50, $4\%$ , semi.	12 yrs. hence	$8\%$ , semi.

3. (a)–(e) Calculate the values in Ex. 2 (a)–(e).

4. How much must we deposit in a bank annually for 20 years, beginning now, in order to draw out \$600 a year for 15 years beginning 30 years from now, if interest is at  $3\frac{1}{2}\%$ ? (*Hint*: Equate the total present value of all the deposits to the total present value of all the withdrawals.)

5. (a) Express by a formula the amount which we could draw out quarterly in 60 installments beginning 20 years hence, if we deposit \$300 semiannually 30 times beginning now, and interest is at  $4\%$ .

(b) Calculate the amount in (a).

§ 314. **Infinite Series.** It is sometimes necessary to deal with a *G. P.* or other series of terms which runs on indefinitely, — never ending. Such an “infinite series” cannot in any literal sense be said to have a sum. But we may need to find the sum of any number of terms, and see what happens as more and more terms are added on.

To illustrate, consider the simple series

$$1, \quad -x, \quad +x^2, \quad -x^3, \quad +x^4, \quad \dots \text{ (unending).}$$

The sum of the first  $n$  terms (a *G. P.* having  $a=1$ ,  $r=-x$ ) is

$$S_n = \frac{1 \cdot [(-x)^n - 1]}{(-x) - 1} = \frac{1}{1+x} [1 \pm x^n].$$

If  $x$  is numerically less than 1, then  $x^n \rightarrow 0$  as  $n \rightarrow \infty$ . And the limit of  $S_n$  is simply  $1/(1+x)$ .

This *limit* is called the *sum of the series to infinity*. We write simply

$$\frac{1}{1+x} = 1 - x + x^2 - x^3 + \dots \quad (6)$$

We do not mean by this that the fraction equals the sum of several terms, but that it is the *limit* approached by the sum as more and more terms are taken. The idea is the same as when we write

$$\frac{1}{3} = .1111 \dots = \frac{1}{10} + \frac{1}{100} + \frac{1}{1000} + \frac{1}{10000} + \dots$$

The fact that the fraction is the limit approached, is also expressed by saying that the series “converges toward the value of the fraction.” Remember, however, that it does so in the example above only when  $x$  is numerically less than 1.

§ 315. **An Application.** In more advanced courses it is proved legitimate to differentiate or integrate an infinite power series term by term: the resulting series will equal the derivative or integral of the function represented by the original series. Let us integrate both sides of (6) above:

$$\log(1+x) = x - \frac{x^2}{2} + \frac{x^3}{3} - \frac{x^4}{4} \dots + C. \quad (7)$$

When  $x=0$ , this gives  $\log 1 = C$ .  $\therefore C=0$ .

This equation is valid if  $x$  is numerically less than 1. *E.g.*,  
letting  $x = .1$ ,

$$\log 1.1 = .1 - \frac{.01}{2} + \frac{.001}{3} \dots = 1 - .005 + .0003 \dots,$$

$$\therefore \log 1.1 = .9953, \text{ approx.} \quad (\text{Base } e.)$$

In this way we can calculate the logarithms of numbers near 1. The logarithms of larger numbers are found by a combination of series.

*Remark.* In obtaining the differentiation formula for  $\log u$  (§ 177), — used above in integrating (6), — we employed tables of logarithms of numbers near 1. But that formula can be obtained otherwise. Hence (7) could have been used to calculate the tables originally.

**§ 316. Maclaurin's Series.** Equation (7) above expresses the function  $\log(1+x)$  as the "sum" of an infinite series of powers of  $x$ . This suggests that perhaps many other functions, such as  $\sin x$ ,  $e^x$ , etc., might be similarly expressed.

This is indeed the case; and it is easy to determine precisely what the series should be for any ordinary function. An example will make the process clear.

**Ex. I.** Assuming that  $\cos x$  equals *some* series of the form

$$\cos x = A + Bx + Cx^2 + Dx^3 + Ex^4 + \dots, \quad (8)$$

find what the coefficients  $A$ ,  $B$ ,  $C$ , etc., must be.

The method is simply to differentiate several times, and then substitute  $x=0$  in each of the resulting equations, — and in the original equation.

Substituting  $x=0$  in (8) gives at once  $\cos 0 = A$ , or  $A = 1$ .

Differentiating (8) repeatedly :	Putting $x = 0$ :
$-\sin x = B + 2Cx + 3Dx^2 + 4Ex^3 + \dots$	$\therefore -\sin 0 = B, = 0$
$-\cos x = 2C + 6Dx + 12Ex^2 + \dots$	$\therefore -\cos 0 = 2C, = -1$
$+\sin x = 6D + 24Ex + \dots$	$\therefore \sin 0 = 6D, = 0$
$+\cos x = 24E + \dots$	$\therefore \cos 0 = 24E, = 1$



Continuing thus we have  $A=1$ ,  $B=0$ ,  $C=-\frac{1}{2}$ ,  $D=0$ ,  $E=\frac{1}{24}$ , etc. Substituting these values in (8), that series becomes

$$\cos x = 1 + 0 \cdot x - \frac{1}{2} x^2 + 0 \cdot x^3 + \frac{1}{24} x^4 \dots,$$

or simply

$$\cos x = 1 - \frac{x^2}{2} + \frac{x^4}{24} \dots \quad (9)$$

That is, if  $\cos x$  is the "sum" of any series of the form (8), this must be the series. It can also be proved that this series (9) does actually approach  $\cos x$  as its limiting value, no matter how large  $x$  may be.

*Remarks.* (I) In (9)  $x$  is necessarily the number of *radians* in the angle. (Why so?)

(II) The possibility of expanding many functions into series of the form (8) was discovered by C. Maclaurin, a Scotchman, about 1740; and series of this type are called Maclaurin series. These are, however, only a special case of a more general type of power series expansion discovered by B. Taylor, an Englishman, about 1715.

(III) Maclaurin series are useful not only in calculating values of a function (§§ 315, 318), but also in performing integrations otherwise difficult or impossible. For instance, from (9) we could find:

$$\int \frac{1 - \cos x}{x} dx = \int \left( \frac{x}{2} - \frac{x^3}{24} \dots \right) dx = \frac{x^2}{4} - \frac{x^4}{96} \dots,$$

- an integral not otherwise obtainable by elementary methods.

**§ 317. Factorial Notation.** The product of the integers from 1 to  $n$  inclusive is called "*factorial n*," and is denoted by  $n!$ . Thus  $5! = 1 \cdot 2 \cdot 3 \cdot 4 \cdot 5 = 120$ . And so on.

By means of this notation the series for  $\cos x$  in (9) above can be written more conveniently. Thus the denominator 24, which arose as  $4 \cdot 3 \cdot 2 \cdot 1$  in the repeated differentiations, is simply  $4!$ . Likewise the denominator 2 may be written  $2!$ , and series (9) becomes

$$\cos x = 1 - \frac{x^2}{2!} + \frac{x^4}{4!} \dots \quad (10)$$

According to this beginning, how should the series continue? Can you tell from the derivation of (9) whether your inference is correct?

## EXERCISES

1. Find Maclaurin's series for  $e^x$  as far as  $x^5$ . By inspection write three more terms. What would be the term containing  $x^{20}$ ?  $x^n$ ?

2. In the series of Ex. 1 substitute  $x = 1$  and thus calculate  $e$  approximately. (The calculation can quickly be carried to many decimals; for dividing the third term by 3 gives the fourth, dividing this by 4 gives the fifth, and so on.)

3. Differentiate the series for  $e^x$  and note the result carefully.

4. Approximate  $\int \frac{e^x - 1}{x} dx$  as far as  $x^4$ .

5. What does the series for  $e^x$  become if we replace  $x$  throughout by  $-x^2$ ? Use the resulting series to find  $\int_0^1 e^{-x^2} dx$  to 5 decimals.

6. Find Maclaurin's series for  $\sin x$ , as far as  $x^5$ . Write three more terms by inspection.

7. Calculate  $\sin .2^{(r)}$  and compare the tables.

8. The same as Ex. 7 for  $\sin 1^\circ$ . (Express  $1^\circ$  in radians.)

9. By differentiating the series for  $\sin x$  obtain a series for  $\cos x$ , and compare (10) above.

10. Derive the cosine series also by integrating the sine series. Note the constant of integration.

11. (a) Find  $\int_0^{\frac{1}{2}} \frac{\sin x}{x} dx$ . (b) Find  $\int_0^1 \frac{1 - \cos x}{x^2} dx$ .

12. Expand  $(a+x)^5$  into a Maclaurin series as far as possible. [ $a$  is constant.]

13. Expand  $(a+x)^n$  as far as  $x^5$ .

[14.] In the series for  $e^x$  in Ex. 1 let  $x = \sqrt{-1} u$ , and simplify. Collect separately the terms free from  $\sqrt{-1}$  and those involving it, and compare the cosine and sine series.

§ 318. **Calculation of Trigonometric Tables.** The sine and cosine of  $1^\circ$  are easily calculated by substituting the radian equivalent of  $1^\circ$ , viz.,  $x = .017453$ , in the Maclaurin series:

$$\begin{aligned}\sin x &= x - \frac{x^3}{3!} + \frac{x^5}{5!} \dots, \\ \cos x &= 1 - \frac{x^2}{2!} + \frac{x^4}{4!} \dots.\end{aligned}\tag{11}$$

The Addition Formulas, § 280, will then give the sine and cosine for  $(1^\circ + 1^\circ)$  or  $2^\circ$ ; then for  $3^\circ, 4^\circ$ , etc., to  $45^\circ$ . Beyond  $45^\circ$  we need not go. (Why not?) Tangents can be found from the sines and cosines. (How?)

The Half-Angle Formulas, § 283, can be used for certain fractions of  $1^\circ$ . Or  $\sin 1'$  and  $\cos 1'$  can be calculated from the series (11), making a fresh start.

Still other methods were used in calculating the tables originally.

**§ 319. Binomial Theorem.** The standard formula for expanding  $(a+u)^n$  is obtainable by Maclaurin's method :

$$\begin{array}{l|l} (a+u)^n = A + Bu + Cu^2 + Du^3 + Eu^4 \dots & A = a^n \\ n(a+u)^{n-1} = B + 2Cu + 3Du^2 + 4Eu^3 \dots & B = na^{n-1} \\ n(n-1)(a+u)^{n-2} = 2C + 6Du + 12Eu^2 \dots & C = \frac{n(n-1)}{2!}a^{n-2} \end{array}$$

. . . . .

$$\begin{aligned} \therefore (a+u)^n &= a^n + na^{n-1}u + \frac{n(n-1)}{2!}a^{n-2}u^2 \\ &\quad + \frac{n(n-1)(n-2)}{1 \cdot 2 \cdot 3}a^{n-3}u^3 + \dots \end{aligned} \quad (12)$$

This formula is called the *Binomial Theorem*. Notice how the terms run. The exponent of  $a$  is  $n$  at first and decreases by 1 at each step. The exponent of  $u$  increases simultaneously, keeping the sum of the two exponents always equal to  $n$ . In the coefficients, notice the factorial denominators; and also that each new factor in the numerator is less by 1 than the preceding. (Judging by the fourth term, what would the sixth be?)

From these facts you can see that the  $r$ th term will involve  $(r-1)!$  in the denominator,  $u^{r-1}$ ,  $a^{n-(r-1)}$ , and factors from  $n$  down to  $(n-r+2)$  in the numerator :

$$r\text{th term} = \frac{n(n-1)(n-2) \dots (n-r+2)}{(r-1)!} a^{n-r+1} u^{r-1}. \quad (13)$$

If  $n$  is an integer, the series (18) will end presently. (When?)

If  $n$  is a fraction the series never ends; but, as is proved in higher algebra, the series converges, and the sum of  $r$  terms approaches the value of  $(a+u)^n$ , provided  $u < a$  numerically.

Certain facts as to the Binomial Theorem were pointed out in obtaining the differentiation formula for  $x^n$ . (§ 56.) We have now gone farther, and have used that differentiation formula to get fuller information about the Binomial Theorem. An independent and purely algebraic proof of this theorem can also be given.

The Binomial Theorem has many uses, both in making numerical calculations and in integrating radical forms which will yield to no other treatment.

Ex. I. Find  $\int_0^2 \sqrt{1-x^3} \cdot dx$ .

The radical is a case of  $(a+u)^n$ , where  $a=1$ ,  $u=-x^3$ ,  $n=\frac{1}{2}$ . Clearly every power of " $a$ " equals 1 here and need not be written. Thus:

$$\begin{aligned} (1-x^3)^{\frac{1}{2}} &= 1 + \frac{1}{2}(-x^3)^1 + \frac{\frac{1}{2}(-\frac{1}{2})}{2!}(-x^3)^2 \\ &\quad + \frac{\frac{1}{2}(-\frac{1}{2})(-\frac{3}{2})}{3!}(-x^3)^3 + \dots \\ &= 1 - \frac{1}{2}x^3 - \frac{1}{8}x^6 - \frac{1}{16}x^9 - \dots \end{aligned}$$

$$\begin{aligned} \therefore \int_0^2 \sqrt{1-x^3} dx &= \left[ x - \frac{1}{8}x^4 - \frac{1}{56}x^7 - \frac{1}{160}x^{10} - \dots \right]_0^2 \\ &= .2 - \frac{1}{8}(.0016) - \dots = .1998. \end{aligned}$$

This definite integral could be approximated by Simpson's Rule; but here we have found the indefinite integral also, valid if  $x < 1$ .

### EXERCISES

1. Write the following expansions, and simplify the terms:

- |   |   |
|---|---|
| (a) $(2+x)^{10}$ , as far as $x^5$ ,            | (b) $(3-x)^4$ , complete.                 |
| (c) $(1+x^4)^8$ , as far as $x^{12}$ ,          | (d) $(2+x^2)^5$ , complete.               |
| (e) $(1-x^2)^{\frac{1}{2}}$ , as far as $x^6$ , | (f) $(1-x^4)^{-\frac{1}{2}}$ , to $x^8$ . |
| (g) $(1-x)^{-1}$ , as far as $x^4$ ,            | (h) $(3+x^4)^{-2}$ , to $x^{12}$ .        |

2. Find  $1/(1-x)$  by division as far as  $x^4$  and compare Ex. 1 (g).  
From this series find by integration a series for  $\log(1-x)$ .

3. From the series in Ex. 2 for  $\log(1-x)$  calculate:

$$(a) (\log .95), \quad (b) \int_0^{.3} \log(1-x) dx.$$

4. Find  $\int \sqrt{1+x^3} dx$  approximately by expanding to four terms.

5. The same as Ex. 4, for  $\int_0^{.5} dx/\sqrt{1-x^4}$ .

6. Find  $\sqrt[3]{1.06}$  approximately by regarding this as  $(1+.06)^{\frac{1}{3}}$  and expanding to three terms.

7. The same as Ex. 6 for  $\sqrt{.982} [= (1-.018)^{\frac{1}{2}}]$ .

**§ 320. Relation of Exponential to Trigonometric Functions.** There is a very close connection between the exponential series

$$e^x = 1 + x + \frac{x^2}{2!} + \frac{x^3}{3!} + \frac{x^4}{4!} + \dots \quad (14)$$

and the sine and cosine series

$$\begin{aligned} \sin x &= x - \frac{x^3}{3!} + \frac{x^5}{5!} - \frac{x^7}{7!} + \dots, \\ \cos x &= 1 - \frac{x^2}{2!} + \frac{x^4}{4!} - \frac{x^6}{6!} + \dots, \end{aligned} \quad (15)$$

as will be obvious if we let  $x$  have an imaginary value, say  $x = \sqrt{-1} u$ , in (14).

$$\begin{aligned} e^{\sqrt{-1}u} &= 1 + \sqrt{-1}u + \frac{(\sqrt{-1}u)^2}{2!} + \frac{(\sqrt{-1}u)^3}{3!} + \frac{(\sqrt{-1}u)^4}{4!} + \dots \\ &= 1 + \sqrt{-1}u - \frac{u^2}{2!} - \frac{\sqrt{-1}u^3}{3!} + \frac{u^4}{4!} + \dots \end{aligned}$$

Or, separating the real terms from the imaginaries,

$$e^{\sqrt{-1}u} = \left(1 - \frac{u^2}{2!} + \frac{u^4}{4!} - \dots\right) + \sqrt{-1} \left(u - \frac{u^3}{3!} + \frac{u^5}{5!} - \dots\right).$$

The two sets of terms in parentheses are seen to be simply the cosine and sine series (15). Hence

$$e^{\sqrt{-1}u} = \cos u + \sqrt{-1} \sin u. \quad (16)$$

In this equation  $u$  is the number of *radians* in the angle. (Why?)

*N.B.* To speak of an imaginary power of  $e$  is meaningless in the ordinary sense of a power. But since (14) is valid for all real values of  $x$ , this series is commonly taken as the *definition* of what is to be understood by an imaginary power.

(What is the definition of  $10^{-3}$ ? Why is that definition adopted?)

**§ 321. Imaginary Logarithms.** When  $u = \pi$ , equation (16) above becomes

$$e^{\pi\sqrt{-1}} = \cos \pi + \sqrt{-1} \sin \pi. \quad (17)$$

But in radian measure,  $\cos \pi = -1$  and  $\sin \pi = 0$ .

$$\therefore e^{\pi\sqrt{-1}} = -1.$$

Thus  $-1$  equals  $e$  raised to this imaginary power. Or, with  $e$  as base:

$$\log(-1) = \pi\sqrt{-1}, = 3.1416\sqrt{-1}.$$

It is equally true, however, letting  $u = 3\pi, 5\pi$ , etc., that

$$e^{3\pi\sqrt{-1}} = -1, \quad e^{5\pi\sqrt{-1}} = -1, \quad \text{etc.}$$

Hence  $-1$ , though it has no real logarithm, has an unlimited number of imaginary logarithms,

$$\pi\sqrt{-1}, \quad 3\pi\sqrt{-1}, \quad 5\pi\sqrt{-1}, \quad \text{etc.}$$

Similarly any positive number, though it has only one real logarithm, has infinitely many imaginary logarithms, likewise differing by multiples of  $2\pi\sqrt{-1}$ . (Cf. Ex. 1 below.)

The theory of imaginary logarithms, developed fully in higher courses, is basic for advanced studies in electrical engineering.

**§ 322. Fourier Series.** If we plot the function

$$y = \sin x + \frac{1}{3} \sin 3x - \frac{1}{5} \sin 5x + \frac{1}{7} \sin 7x \cdots,$$

the graph turns out to be a set of connected straight lines, as in Fig. 143.

Conversely (as was shown about 1820 by J. B. J. Fourier, a Frenchman), if we have given this broken-line graph, or any other graph which has a definite height at every point and a limited number of discontinuities and maxima and minima, the function represented by it can be expressed as the "sum" of an infinite series of sines (or cosines, or both).

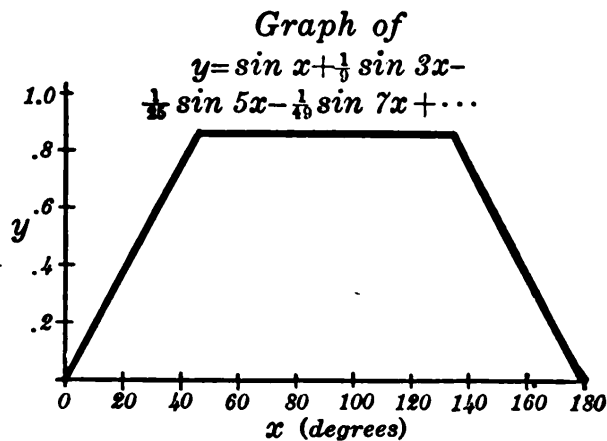

FIG. 143.

Such "Fourier series" are treated in detail in higher courses, being admirably adapted to the study of the vibrations of a string of a musical instrument, other types of wave motion, the flow of heat, etc.

The Fourier series for any given graph can be found as far as the first 80 terms by a machine, called an "harmonic analyzer," invented by Lord Kelvin and improved by A. A. Michelson. For instance, it will give an approximate equation for a human profile!

### EXERCISES

1. In formula (16) substitute the following values for  $x$ , also each value plus  $2\pi$  or  $4\pi$ , and interpret each result in terms of logarithms:

- |                    |                   |                   |
|--------------------|-------------------|-------------------|
| (a) $x = \pi/2$ ,  | (b) $x = \pi/3$ , | (c) $x = \pi/4$ , |
| (d) $x = 3\pi/4$ , | (e) $x = 1$ ,     | (f) $x = 2$ .     |

2. Formula (16) is valid only if  $x$  denotes the number of *radians* in the angle considered. Why so?

3. Make a table of values for  $x = 0^\circ, 30^\circ, 60^\circ$ , etc., to  $360^\circ$ , and plot:

- (a)  $y = \sin x + \frac{1}{3} \sin 3x + \frac{1}{5} \sin 5x \dots$ ,  
 (b)  $y = \sin x - \frac{1}{3} \sin 3x + \frac{1}{5} \sin 5x - \frac{1}{7} \sin 7x \dots$ ,  
 (c)  $y = \cos x - \frac{1}{3} \cos 3x + \frac{1}{5} \cos 5x - \frac{1}{7} \cos 7x \dots$ ,  
 (d)  $y = \cos x + \frac{1}{3} \cos 3x + \frac{1}{5} \cos 5x + \frac{1}{7} \cos 7x \dots$

**§ 323. Discovery of Laws Resumed.** In §§ 32 and 175 we saw how to discover certain types of scientific laws, viz., Linear, Power, and Compound Interest Laws. We may now consider two further types: Trigonometric and Polynomial Laws.

By using an harmonic analyzer any law can be approximated in the form of a Fourier series. But simpler types of trigonometric laws can often be discovered by drawing the graph and recognizing it as a sine curve, cosine curve, or some simple combination of these.\*

**§ 324. Polynomial Laws.** A quantity  $y$  sometimes varies according to some polynomial formula of the type

$$y = A + Bx + Cx^2 + \dots \quad (18)$$

Whenever this is the case, it is easy to discover the fact from a given table of values, and to find the proper values for the coefficients  $A$ ,  $B$ ,  $C$ , etc.

Suppose that the values of  $x$  in the table run at constant intervals,  $\Delta x = k$ . (If they do not, we can plot a graph and read off values which do.)

Form the differences ( $\Delta y$ ) between successive  $y$  values. If these vary, form *their* successive differences, and denote these "second-order differences" by  $\Delta^2 y$ . If these also vary, form *their* differences ( $\Delta^3 y$ ). And so on.

If the first-order differences ( $\Delta y$ ) are constant,  $y$  increases at a constant rate, and the tabulated values satisfy a first degree formula. More generally:

**THEOREM.** *If the differences ( $\Delta^n y$ ) of order  $n$  are constant, the tabulated values of  $x$  and  $y$  satisfy a formula of degree  $n$ . And conversely.*

\* This has been done with considerable accuracy in studying apparent cycles of rainfall in the Ohio valley during some decades past. See H. L. Moore, *Economic Cycles, Their Law and Cause*.



This theorem, proved in more advanced courses, makes it possible to discover any Polynomial Law.

Ex. I. Discover the law for the following table.

Table:	$x$	7	17	27	37	47	57
	$y$	60	136	192	228	244	240
1st Diffs.,	$\Delta y$	76	56	36	16	-4	
2d Diffs.,	$\Delta^2 y$	-20	-20	-20	-20		

These second-order differences being constant ( $= -20$ ), the required formula is of the second degree:

$$y = A + Bx + Cx^2.$$

To find  $A$ ,  $B$ ,  $C$ , we substitute values of  $x$  and  $y$  from the table:

$$240 = A + 57B + 3249C$$

$$192 = A + 27B + 729C$$

$$60 = A + 7B + 49C$$

Subtracting the third equation from each of the others gives two equations free from  $A$ . Solving these for  $B$  and  $C$ , and substituting back to get  $A$ , we obtain finally  $A = -5.1$ ,  $B = 10$ ,  $C = -.1$ . Hence the required formula is

$$y = -5.1 + 10x - .1x^2.$$

This is satisfied by all the tabulated values, as direct substitution would show.

*Remark.* If the differences never become exactly constant, but are very nearly so at some stage, the discrepancies may be due to slight experimental errors in the table. Anyhow, an approximate polynomial formula can be obtained by substituting as above. (This will be a sort of Maclaurin series for the function.) The most probable values of  $A$ ,  $B$ ,  $C$ , etc., can be found as in §§ 342-343, later.

### EXERCISES

1. From the formula  $y = x^2 - 7x + 3$  calculate a table of values of  $y$  when  $x = 0, 10, 20, 30, 40$ , and  $50$ . Verify that the second differences  $\Delta^2 y$  are constant in your table.

2. Proceed as in Ex. 1 with the formula  $y = .1x^3 + .2x + 5$ , and show that your third differences  $\Delta^3 y$  are constant.

3. Discover a formula satisfied by the values in each of the following tables:

(a)	$x$	0	2	4	6	8	10
	$y$	0	32	88	168	272	400
(b)	$x$	0	5	10	15	20	25
	$y$	-7	-2	13	38	73	118
(c)	$x$	10	20	30	40	50	60
	$y$	-15	-5	25	75	145	235
(d)	$x$	0	2	4	6	8	10
	$y$	11	13	11	-7	-53	-139
(e)	$x$	10	20	30	40	50	60
	$y$	3.10	3.76	4.15	3.97	2.92	.70

(f) Table 5, p. 31. Solve Ex. 5, p. 31, exactly.

4. The same as Ex. 3 for the following tables. (Observe that the intervals  $\Delta x$  are unequal.)

(a)	$x$	0	24	62	110	218	290
	$y$	125	113	94	70	16	-20
(b)	$x$	0	5	8	13	16	20
	$y$	0	75	96	91	64	0

§ 325. **Summary of Chapter XIII.** Formulas relating to *A. P.*'s and *G. P.*'s can be used to solve problems on investments for which no tables would serve. Also they may be used to calculate further tables.

Many functions can be expressed as the "sum" of an infinite series of powers of  $x$  [Maclaurin] or sines and cosines of multiples of an angle [Fourier]. By the "sum" of such a series in general is meant the *limit* approached by the sum of  $n$  terms as  $n \rightarrow \infty$ . If no limit is approached, we cannot speak of the "sum" of the series.

Various useful approximations are obtained by taking the first few terms of a series. Logarithmic and trigonometric tables may be so calculated. Many indefinite integrals can be obtained as infinite series — and in no simpler form.

Functions of *imaginary* variables are usually defined by means of series which are valid when the variables are real. In this way we can give a meaning to imaginary logarithms.

When the values in a table satisfy a trigonometric or poly-

nomial law, the formula can usually be discovered. Formulas are called *empirical* when found to fit a table.

We shall next consider some further topics of algebra, closely related to series and the binomial theorem, which are basic in the scientific study of statistics.

### EXERCISES

Express the answers to Exs. 1–5 by formulas ready for calculation.

1. If we make 40 semiannual deposits of \$300 each, beginning now, and interest is at 4% compounded semiannually, how much will there be to our credit 30 years hence?

2. What sum set aside annually, 15 times, beginning 1 year hence, would provide a sinking fund amounting to \$50,000 twenty years hence, if interest is at 5%, compounded quarterly?

3. What sum set aside now by the state would provide an accident indemnity of \$600 a year, for 30 years, beginning 1 year hence, if interest is at 6%?

4. How much should an insurance company pay annually for 20 years, beginning 1 year hence, in lieu of paying \$20,000 now, if it earns 5%?

5. What is the present value of a \$1000 bond bearing  $4\frac{1}{2}\%$  interest payable semiannually, and maturing 15 years hence, if money is now worth  $4\frac{3}{4}\%$ , compounded semiannually?

6. Approximate  $\sqrt[3]{1.012}$  by the Binomial Theorem.

7. As in Ex. 6 find an approximate formula for  $\sqrt[3]{1 \pm x}$  when  $x$  is very small. Use your formula to find  $\sqrt{1.0008}$ ,  $\sqrt[4]{1.0032}$ ,  $\sqrt[5]{.998}$ .

8. In finding the ratio of the lever arms of a fine balance, it was necessary to approximate  $\sqrt{1.000\ 000\ 023}$ . Do this by inspection.

9. Discover a formula satisfied by the values in this table:

$x$	10	20	30	40	50	60
$y$	3	28	103	228	403	628

10. A debt of \$1000 is to be paid off, beginning now, by paying \$100 monthly on the principal, plus interest at 6%. How much will be paid in all?

11. Find Maclaurin's series for  $\log(1+x)$  as far as  $x^4$ . Use it to calculate  $\log 1.2$ , and compare tables.

[12.] How many different "chords" could be sounded by striking three of the four keys A, C, E, G? Write out the combinations.

[13.] How many code "words" could be spelled by using any three of the four letters A, C, E, G?

## CHAPTER XIV

### PERMUTATIONS, COMBINATIONS, AND PROBABILITY

#### FUNDAMENTALS OF STATISTICAL METHOD

**§ 326. The Problem of Arrangements.** It is sometimes useful to know in how many different orders a given set of objects can be arranged, — using all or a part of the set at a time. Such questions may be reasoned out as follows :

**EXAMPLE.** Three flags are to be placed in a vertical row as a signal. If we have seven different flags, how many signals are possible?

The top place can be filled by any one of the seven flags, — that is, in 7 ways. The middle place can then be filled in 6 ways; and the lowest place in 5 ways. For *each* way of filling the first place, there are 6 ways of filling the second: hence  $7 \times 6$  ways of filling the first two places. Similarly there are  $7 \times 6 \times 5$  ways of filling the three places. *I.e.*, there are  $7 \times 6 \times 5$  possible signals.

**§ 327. Formula.** The foregoing example shows that the number of possible orders of 7 objects taken 3 at a time is  $7 \times 6 \times 5$ . Can you see from this how many orders are possible for 9 objects taken 4 at a time? For 13 objects taken 6 at a time?

An order, or arrangement in sequence, is also called a “permutation.” The number of permutations of  $n$  objects taken  $r$  at a time is denoted by  $P_{n,r}$ . Thus the result in the example above may be written

$$P_{7,3} = 7 \times 6 \times 5. \quad (3 \text{ factors, from } 7 \text{ down.})$$

This suggests that  $P_{n,r}$  is the product of  $r$  factors, viz.,

$$P_{n,r} = n(n-1)(n-2) \cdots (n-r+1). \quad (1)$$

To prove this, simply reason as in the example above.

If all  $n$  objects are used every time,  $n=r$ ; and hence

$$P_{n,n} = n(n-1)(n-2) \cdots 1, \text{ or } P_{n,n} = n!. \quad (2)$$

*E.g.*, the number of possible orders for 6 books on a shelf is  $6!$  ( $=720$ ).

*Remark.* Factorial notation can be used to express  $P_{n,r}$ , also. For multiplying  $P_{n,r}$  by  $(n-r)!$  would give all the factors from  $n$  down to 1, — or  $n!$  That is,

$$P_{n,r} = \frac{n!}{(n-r)!}. \quad (3)$$

Ex. I. How many batting orders are possible for a ball nine to be selected at random from 12 men?

$$\text{Ans. } P_{12,9} = \frac{12!}{3!} = 12 \cdot 11 \cdot 10 \cdot 9 \cdot 8 \cdot 7 \cdot 6 \cdot 5 \cdot 4.$$

**§ 328. Restricted Arrangements.** Whenever an arrangement is to be made, subject to some restriction, it is important to consider the restricted groups first.

Ex. I. On each side of a car are 30 seats. In how many ways can 60 persons be seated, 20 of whom insist upon sitting on the sunny side?

We first take 20 of the 30 sunny seats and assign them to the 20 restricted persons in some order. This can be done in  $P_{30,20}$  ( $=30! \div 10!$ ) ways. The other 40 persons may sit anywhere in the remaining 40 seats, in  $P_{40,40}$  [ $=40!$ ] ways.

For *each* seating of the 20 persons, there are  $40!$  seatings of the company as a whole. Hence, in all

$$P_{30,20} \times P_{40,40} \quad \text{or} \quad \frac{30! \cdot 40!}{10!}$$

is the total number of arrangements possible. These factorials are easily computed by logarithmic tables with a special first page.

### EXERCISES

1. (a) How many numbers can be formed, using any three of the digits, 1, 2, 3, 4, 5, and 6, without duplication in any one number?

(b) How many code "words" are possible, using any three letters of the alphabet without duplication?

2. Ten men compete in a race in which the first four places score. In how many ways may the scoring turn out, barring ties?

3. Five persons enter a car in which 8 seats are vacant. In how many ways can they be seated?

4. A class of 15 men meets in a room which has 19 blackboards. In how many ways may the men be assigned one board each?

5. If 10,000 persons register for a drawing of 500 pieces of land of different grades, in how many ways may the allotment result?

6. How many numbers can be formed from 1, 2, 3, and 4, using all the digits each time? Three each time? In all possible ways?

7. In how many numbers between 100 and 1000 is there neither a repeated digit nor a zero?

*Note: If the location of any objects is restricted, consider the arrangement of those objects first.*

8. A car has 20 seats on each side. In how many ways may 40 people be seated if 12 of them insist on sitting on the sunny side?

9. In how many ways may a basketball team line-up if one of the men can play only as a forward, and two of the others only as guards?

10. In how many ways can eleven men line up as a football team, if three of the men can play in the line only, and two others in the backfield only?

11. How many six-place numbers can be formed from the digits 1, 2, 3, 4, 5, and 6, if 3 and 4 are always to occupy the middle two places?

12. In renumbering a city's streets, house numbers were traded extensively. How many numbers could be formed, using all or part of the figures 1, 3, 5, and 7? How many from 8, 6, 2, and 0?

**§ 329. The Problem of Combinations.** It is often important to know how many different *sets* of  $r$  objects can be chosen from  $n$  objects. This is not a question of the number of orders or permutations, but rather the number of *groups* or *combinations*. A set, however, is regarded as different if even a single individual is changed.

**EXAMPLE.** How many triangles can be drawn with vertices chosen from among five points  $A, B, C, D, E$ , no three of which are in the same straight line?

There will be as many triangles as there are sets of three letters.

Each set of 3 letters could be arranged in  $3! (=6)$  different orders. Hence the number of sets is only one sixth as large as the total number of possible orders, — which is  $P_{5,3}$ . Hence the number of sets, or triangles, is

$$\frac{P_{5,3}}{3!} = \frac{5 \cdot 4 \cdot 3}{1 \cdot 2 \cdot 3} = 10.$$

**§ 330. Formula.** The number of sets or combinations of  $r$  objects that can be chosen from  $n$  objects is denoted by  $C_{n,r}$ . Evidently

$$C_{n,r} = \frac{P_{n,r}}{r!}. \quad (4)$$

For each set of  $r$  objects has  $r!$  possible orders; and hence the total number of orders must be  $r!$  times the number of sets.

Or the number of sets  $= \frac{1}{r!} \times$  the number of orders. This gives finally

$$C_{n,r} = \frac{n!}{(n-r)! \cdot r!} = \frac{n!}{r!(n-r)!}. \quad (5)$$

**Ex. I.** How many speaking tubes would be needed to connect each of 5 rooms privately with every other room?

There must be as many tubes as there are *pairs* of rooms, viz.,

$$C_{5,2} = \frac{5!}{2!3!} = \frac{5 \cdot 4}{1 \cdot 2} = 10.$$

**Ex. II.** A pack of 52 cards contains “spades,” “clubs,” “diamonds,” and “hearts” in equal numbers. In how many ways can a hand of 12 cards be drawn, so as to contain precisely 5 spades?

Any 5 of the 13 spades might be drawn, which can be done in  $C_{13,5}$  ways. By hypothesis, the other 7 cards may be any 7 of the 39 clubs, diamonds, and hearts. These can be drawn in  $C_{39,7}$  ways. Each set of 5 spades can go with *any* set of the 7 other cards. The total number of hands possible is then

$$C_{13,5} \times C_{39,7} = \frac{13!}{5!8!} \times \frac{39!}{7!32!}.$$

*Remark.* Formula (5) would give in the case of  $C_{9,9}$

$$C_{9,9} = \frac{9!}{9!0!} = \frac{1}{0!}. \quad (6)$$

Now  $0!$  is meaningless: we cannot speak of the product of the integers starting at 1 and running up to zero. But if we arbitrarily assign the value 1 to  $0!$  (just as we assigned the value 1 to  $x^0$  in § 67) equation (6) will then give  $C_{9,9} = 1$ ; which is clearly correct.

**§ 331. Selecting and Arranging.** When a problem involves both the selection and arrangement of objects, with a limitation upon either, it is best to consider the two steps separately. That is, ask (a) In how many ways can a *suitable set of objects be chosen*, and (b) In how many ways *may each chosen set be arranged*.

Ex. I. How many line-ups are possible, choosing a football eleven of 6 seniors and 5 juniors, from a squad containing 10 seniors and 15 juniors?

(a) The 6 seniors may be chosen in  $C_{10,6}$  ways, the 5 juniors in  $C_{15,5}$  ways. Hence the *set* of players may be chosen in  $C_{10,6} \times C_{15,5}$  ways.

(b) Any one set of 11 men can line up in  $11!$  ways. Hence the total number of possible line-ups is

$$C_{10,6} \times C_{15,5} \times 11! = \frac{10!}{6!4!} \times \frac{15!}{5!10!} \times 11!.$$

[Would it be correct here to reason that the number of orders for the seniors would be  $P_{10,6}$ , and for the juniors  $P_{15,5}$ ; and hence, in all,  $P_{10,6} \times P_{15,5}$ ? No, for this allows only for shifts of the seniors and juniors among themselves and not of seniors with juniors.]

**§ 332.  $C_{n,r}$  in the Binomial Theorem.** The general term in the expansion of  $(a+u)^n$  is by § 319:

$$\frac{n(n-1) \cdots (n-r+1)}{r!} a^{n-r} u^r. \quad (7)$$



If  $n$  is a positive integer, this is the same thing as  $C_{n,r} a^{n-r} u^r$ . Hence the binomial theorem may be rewritten :

$$(a+u)^n = a^n + C_{n,1} a^{n-1} u + C_{n,2} a^{n-2} u^2 + \dots \quad (8)$$

In fact, another proof of the theorem for positive integral values of  $n$  is easily given from the standpoint of combinations.

To illustrate the idea, think of  $(a+u)^{10}$  as

$$(a+u)^{10} = (a+u)(a+u) \dots (a+u), \text{ 10 factors.}$$

Multiplying the  $a$ 's in three factors and the  $u$ 's in the other seven would give  $a^3 u^7$ . This particular term will arise as many times as there are sets of 3 factors, — i.e.,  $C_{10,3}$  times. Hence the expansion will contain  $C_{10,3} a^3 u^7$ .

You may see from this illustration how the proof would run that the coefficient of  $a^r u^{n-r}$  in  $(a+u)^n$  must be  $C_{n,r}$ . Likewise for  $a^{n-r} u^r$ .

### EXERCISES

1. In how many ways could :
  - (a) A committee of five be named from a group of 10 men?
  - (b) A bodyguard of six be chosen from 15 secret service men?
  - (c) Six trees be selected from 20 for cutting?
  - (d) A bowling team of four be chosen from a club of 25 men?
  - (e) A jury of 12 men be drawn in a town where 500 are eligible?
  - (f) Five sprinters draw "lanes" if the track has six in all?
  - (g) A president, a secretary, and a treasurer be elected from a club membership of 32?
  - (h) A dramatic club of 10 be chosen from a public-speaking class of 25?
  - (i) Six speakers find seats on a platform containing 8 chairs?
  - (j) Thirty out of 100 passengers be admitted to the "diner" on the "first call"?
  - (k) A clown make up a three-piece "suit," if he has 8 coats, 4 vests, and 10 pairs of trousers?
  - (l) A committee of six Republicans and five Democrats be chosen from a legislature of 47 Republicans and 41 Democrats?
  - (m) A collection of 3 gold coins and 4 silver coins be selected from 8 gold and 11 silver pieces, all different?
  - (n) An arbitration board consisting of 3 employers, 3 laborers, and 3 outsiders be chosen from 12 employers, 20 laborers, and 7 outsiders?

2. If there are 8 "jitneys" in one town and 3 'busses in another, in how many ways could the round trip be made, going by "jitney" and returning by 'bus?

3. In a group of 10 houses, how many speaking tubes are needed to connect each house privately with every other one?

4. How many possible committees of 5 could be selected from 50 senators, of whom only 8 are able to serve as chairman, and these 8 are unwilling to serve otherwise?

5. In how many ways can a university fill vacancies consisting of 3 instructorships of equal rank in physics, 2 in chemistry, and 4 in English, from 5 available candidates in physics, 6 in chemistry, and 20 in English?

6. How many batting orders are possible for a ball nine if the outfielders must bat before any of the other players, and catcher and pitcher bat after all the others?

7. From 10 seniors and 8 juniors how many basketball teams can be chosen, if each includes 3 seniors and 2 juniors? How many "line-ups" are obtainable thus?

8. How many line-ups are possible for a ball nine, if only 3 men can pitch or catch, but every man can play any other position?

9. How many football line-ups are obtainable from a squad of 30, if only 5 can play as ends and only 7 as backs, and these 12 men can play nowhere else?

10. If we draw 5 balls at random from a bag containing 8 red and 12 white balls, in how many ways may we get 3 red and 2 white?

11. In how many ways can 20 books be shelved in a row, without separating one set of 5 volumes or another of 4 volumes?

12. If we draw 9 cards from a pile containing 10 "spades" and 8 "hearts," in how many ways may we get 6 spades and 3 hearts?

13. Ten men enter a Marathon race in which various prizes are offered for winner, second, third, and fourth men. In how many ways may the prizes fall?

14. How many different recitation schedules could a student get, in registering for 3 out of 8 electives, which come at different hours?

15. How many straight lines are determined by 12 points on a given circle? How many triangles have three of those points as vertices?

16. Write the expansions of the following binomials, expressing their coefficients in the  $C_n, r$  notation:

(a)  $(a+x)^5$ ;

(b)  $(a^2-y^2)^{10}$ , to four terms.

(c)  $(1+1)^7$ . [Note the expression thus obtained for  $2^7$ .]

§ 333. **The Idea of Chance.** The theory of chance is fundamental in many lines of scientific work — *e.g.*, in statistical studies of physical, biological, and social phenomena, in the theory of errors of measurement, etc. The basic ideas of chance underlying these studies are familiar to every one, as the following illustrations will show.

(1) If we toss up a coin, we say that the chance of its falling “heads” is  $1/2$ . We mean that it may fall in either of two ways, which are regarded as equally probable. In several thousand trials we should expect “heads” just about half the time, and “tails” about half.\*

(2) If we name a date at random, as May 12, 1987, the chance that it will be a Tuesday is  $1/7$ . For there is no reason to suppose that we are any more likely or less likely to hit upon Tuesday than any other day of the week.

(3) If we draw a ball at random from a bag containing 3 red and 7 black balls, the chance or probability that it will be red is  $3/10$ .

§ 334. **Probability Defined.** If an event can occur in  $x$  ways, and can fail in  $y$  ways all apparently equally likely, we say that the probability of success ( $p$ ) and the probability of failure ( $q$ ) are respectively :

$$p = \frac{x}{x+y}, \quad q = \frac{y}{x+y}. \quad (9)$$

That is, the probability of an event equals *the number of ways it can occur, divided by the total number of ways it can occur or fail.*

\* When we speak of the turn of a coin as a “chance event,” we do not mean to imply that there is nothing which determines how it will fall. But the determining factors are so complex, — and so far beyond our knowledge when the coin is honestly flipped, — that we are quite unable to predict the fall. And we sum all this up in calling the turn of the coin a “chance event.”

Observe that  $p+q=1$ . That is, the chance of success + the chance of failure equals 1. If an event is sure to occur,

$$y=0.$$

$$\therefore p=1.$$

Thus 1 is the symbol of *certainty* in questions of chance.\*

Ex. I. If 5 balls are drawn at random from a bag containing 7 red and 8 black balls, what is the chance for 3 red and 2 black balls?

Any three of the 7 red balls might be drawn: this could happen in  $C_{7,3}$  ways. Likewise two black balls could be drawn in  $C_{8,2}$  ways; and hence the required combination can be obtained in  $C_{7,3} \times C_{8,2}$  ways. But the total number of ways of drawing some 5 balls is  $C_{15,5}$ . Hence the probability of succeeding is

$$p = \frac{C_{7,3} \times C_{8,2}}{C_{15,5}} = \frac{7!}{3!4!} \times \frac{8!}{2!6!} = \frac{140}{429}.$$

There is approximately "one chance in 3."

§ 335. **Compound Probability.** What is the probability that two events, *independent of one another*, will both occur?

Suppose the first can occur in  $x_1$  ways and fail in  $y_1$  ways; and that the second can occur in  $x_2$  ways and fail in  $y_2$  ways. Any one result for the first event might be associated with any result for the second. Hence the two events can both occur in  $x_1 x_2$  ways; and can occur or fail in  $(x_1 + y_1) \cdot (x_2 + y_2)$  ways. Thus the chance that *both* will occur is

$$p = \frac{x_1 x_2}{(x_1 + y_1)(x_2 + y_2)} = \frac{x_1}{x_1 + y_1} \cdot \frac{x_2}{x_2 + y_2} = p_1 p_2, \quad (10)$$

where  $p_1$  and  $p_2$  are the probabilities of the two events considered separately.

Ex. I. If a ball is drawn from a bag containing 3 red balls and 7 black ones, and a card is drawn from a pack, what is the probability that the ball will be red and the card a spade?

\* The mathematical study of games of chance will show in general how hopeless it is to try to "beat a game" in the long run.

The chance for a red ball is  $p_1 = 3/10$ . The chance for a spade is  $p_2 = 13/52 = 1/4$ . Hence the required chance is

$$p_1 p_2 = \frac{3}{10} \cdot \frac{1}{4} = \frac{3}{40}.$$

That is, in the long run, a red ball would be drawn in three tenths of all the trials; and, in one fourth of these cases, a "spade" also would be drawn.

Ex. II. What is the chance that a coin tossed 3 times will fall "heads" every time?

The chance for a "head" on any throw is obviously  $1/2$ . Hence for three throws:

$$p = \left(\frac{1}{2}\right)\left(\frac{1}{2}\right)\left(\frac{1}{2}\right) = \frac{1}{8}.$$

[Why would it be incorrect to argue similarly that the chance of drawing a "spade" from a pack is  $1/4$ ; and hence the chance that two cards drawn in succession will both be spades is  $p = (1/4)^2$ ? Would this argument be correct if the first card were replaced before drawing the second?]

### EXERCISES

1. What is the probability: (a) of throwing a "six," when rolling a single die; (b) of getting a "spade" when drawing one card from a "pack," — without the joker; (c) of hitting upon a Monday, when naming a date at random; (d) of choosing a man, when selecting one person by lot from a group of 20 men and 10 women?

2. If 5 balls are drawn from a bag containing 6 red and 9 white balls, what is the probability: (a) that all will be red? (b) that 3 will be red and 2 white?

3. Selecting 5 persons from the group in Ex. 1 (d) what is the probability for 4 men and one woman?

4. Drawing 7 cards out of a pack, what is the chance: (a) that all will be black? (b) that 5 will be black and 2 red?

5. Drawing 7 cards as in Ex. 4 what is the chance: (a) that all will be hearts? (b) that 5 will be hearts and 2 diamonds? (c) that 5 will be hearts and the other two something else?

6. Naming a date at random, and simultaneously selecting 3 persons as in Ex. 1 (d), what is the chance of getting a Friday and 3 men?

7. Drawing 3 balls from the bag in Ex. 2 and simultaneously throwing a die, what is the chance of getting two red balls and a "five" on the die?

8. Drawing three cards from a pack, and simultaneously tossing a coin, what is the probability of 3 aces and a head?

9. (a) If 4 coins are tossed, what is the chance that all will fall "tails"? (b) The same question for 10 coins.

10. If 3 dates are named at random what is the chance: (a) that all will be Sundays? (b) that the first will be a Sunday, and the other two something else?

11. In a certain locality 90% of July days are clear. If three successive days are selected in advance, what is the probability: (a) that all will be clear? (b) that the first two will be clear and the third not?

### § 336. An Illustrative Problem.

If five dice are thrown at random, what is the chance that *some* pair will fall "aces" (*i.e.*, one-spots) and the other three dice fall in some other way?

First consider the probability that a *certain* pair will fall aces, etc.

For each ace the chance is  $1/6$ ; for the pair it is  $(1/6)^2$ . For any other die to fall in some *other* way than ace, the probability is  $5/6$ ; for all three dice to do so it is  $(5/6)^3$ . Hence the chance that a *certain* pair will fall aces, and the others not aces is  $(1/6)^2 (5/6)^3$ .

The chance for *some* pair to fall aces, etc., is much larger, for there are  $C_{5, 2}$  ( $= 10$ ) possible pairs, and any one of these might be the pair to fall aces. Hence the total chance, as required in the question above, is

$$\therefore p = C_{5, 2} \left(\frac{1}{6}\right)^2 \left(\frac{5}{6}\right)^3. \quad (11)$$

This is also the chance that a single die, thrown 5 times, would fall an ace twice and only twice.

§ 337. *r* Successes in *n* Trials. The result in (11) merely illustrates the following theorem: If  $p$  is the chance of success in one trial, and  $q (= 1 - p)$  is the chance of failure, then the probability that the event will occur precisely  $r$  times in  $n$  trials is

$$p_r = C_{n, r} p^r q^{n-r}. \quad (12)$$

**PROOF.** The probability that a *certain*  $r$  trials will all succeed is  $p^r$ ; the probability that all the others will fail is  $q^{n-r}$ ; and the  $r$  successful trials could be selected from  $n$  trials in  $C_{n,r}$  ways.

**Ex. I.** If 20 dates are named at random, what is the chance that precisely 5 will be Sundays?

The chance that a single date would fall on Sunday is  $1/7$ . Thus  $p = 1/7$ ,  $q = 6/7$ ; and hence

$$p_5 = C_{20,5} \left(\frac{1}{7}\right)^5 \left(\frac{6}{7}\right)^{15} = .0913, \text{ approx.}$$

### EXERCISES

1. What is the probability of getting precisely

- (a) Two heads, in flipping 5 coins?
- (b) Four aces, in throwing 10 dice?
- (c) Three Sundays, in naming 25 dates at random?

2. In a certain locality 40% of the days in April are rainy. If 3 days are selected in advance, what is the chance that precisely 2 of them will be rainy days?

3. 80% of the days in June are fair. What is the chance for good weather on 3 consecutive days chosen at random?

4. In a certain class there are 30 men and 25 women. If 5 names are drawn at random from a box containing all 55 names, what is the chance that 3 men and 2 women will be drawn?

5. If 9 coins are tossed up, and simultaneously 2 dice are thrown, what is the chance that 6 of the coins will fall heads and both dice fall fives?

6. If 7 cards are drawn from a pack and 3 dice are thrown, what is the probability for 3 aces among the cards and 2 aces on the dice?

7. If 10 dates are named at random, and 5 coins are tossed, what is the probability that precisely 4 dates will be Mondays and 3 coins fall "heads"?

[8.] If 5 coins are tossed, what is the probability of five heads? Of four heads? (And so on, to no heads.) Represent these several probabilities graphically by ordinates, equally spaced.

[9.] Show that the probability in Ex. 1 (c) equals one term in the expansion of the binomial  $(\frac{1}{7} + \frac{6}{7})^{25}$ .

§ 338. **Normal Binomial Distribution.** If we toss up 10 coins, there are 11 possible results: 10 heads, 9 heads, ..., 1 head, no heads. The chances for these several results

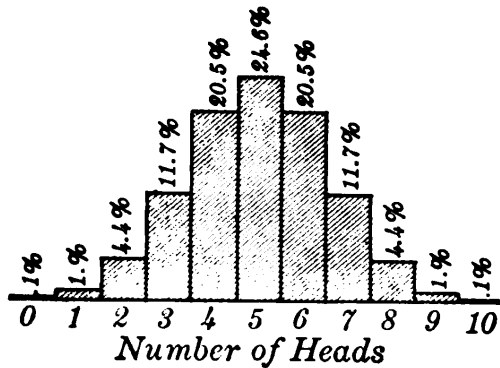

FIG. 144.

(Fig. 145, p. 453, shows the same thing for 100 coins. Observe how slight the chances are for more than 65 heads or fewer than 35.)

The probability of  $r$  heads when tossing  $n$  coins once is

$$p_r = C_{n,r} \left(\frac{1}{2}\right)^r \left(\frac{1}{2}\right)^{n-r}, = C_{n,r} \left(\frac{1}{2}\right)^n.$$

Since the factor  $(1/2)^n$  occurs in every  $p_r$ , the several probabilities  $p_r$  are proportional to the coefficients  $C_{n,r}$  in the expansion of  $(p+q)^n$ . For this reason a distribution of frequencies like that in Fig. 144 is called a *Normal Binomial Distribution*.\* Such distributions are very common in statistical studies. Some illustrations follow.

(I) The “staircase” in Fig. 6, p. 5, which shows the relative commonness of various chest measures among a number of soldiers, resembles a Normal Binomial Distribution. So would a similar chart for *statures*, and many other biological measurements.

(II) A series of rectangles similarly drawn to show the relative frequency of *marriages* at various *ages* also resembles the normal binomial staircase. Likewise for the relative commonness of life

\* The distribution of frequencies for the various possible numbers of “aces” when throwing  $n$  dice is a different type of Normal Binomial Distribution, not symmetrical with respect to the vertical center line, or any other line, —  $p$  and  $q$  being unequal in this case,  $\frac{1}{6}$  and  $\frac{5}{6}$ .



insurance policies taken out at various ages, or of various wages in some industries; etc.

§ 339. **Errors of Measurement.** If we measure the length of a room many times, say with a yardstick, our results will disagree by small fractions of an inch. But the values will tend to cluster closely around their average, — which we would regard as the true value. Errors of  $1/8$  in. or  $1/4$  in. will be far more common than errors of an inch or more. A series of rectangles representing the relative frequency of errors of various sizes will closely resemble the normal binomial “staircase.”

Half of all the errors will be less than a certain small amount, which is called the “probable error.” The other half of the errors will exceed this. With more accurate methods of measuring, the staircase would be condensed from either extreme toward the center, and the “probable error” would be reduced.

§ 340. **Normal Probability Curve.** If instead of 10 coins we toss up 10,000, and draw a “staircase” representing the chances for no head, 1 head, 2 heads, etc., to 10,000 heads, making the bases of the rectangles much smaller, the “staircase” will ascend by such tiny steps as to be practically a smooth curve. (Cf. Fig. 145 for 100 coins.) Indeed, if the bases of the rectangles are suitably decreased while the number of steps is indefinitely increased, the limiting form approached by the staircase can be proved to be the “normal probability curve”:

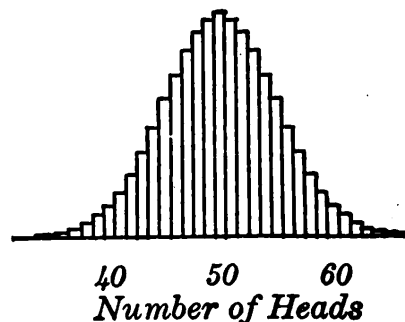

FIG. 145.

$$y = ae^{-nx^2} \quad (13)$$

whose shape is shown in Fig. 146. (See also Fig. 6, p. 5.)

Similarly, in measuring the length of a room, the finer

the units which we distinguish, the more closely will the staircase distribution of errors approach the bell-shaped curve (13). The area of any rectangle represents the probability of making an error within the limits of the base of the rectangle. The area of an "infinitesimal strip"  $y dx$  under the curve represents the probability of an error falling within the tiny base  $dx$ , when exceedingly fine units are distinguished.

Thus the probabilities of making any two errors  $x_1$  and  $x_2$  are to each other as

$$e^{-nx_1^2} \text{ is to } e^{-nx_2^2},$$

canceling the common factor  $dx$ . Here  $n$  is a constant, depending upon the degree of precision attainable with the instruments used.

**§ 341. Errors of Artillery Fire.** If a gun is fired many times, under as nearly the same conditions as possible, the shots will not all

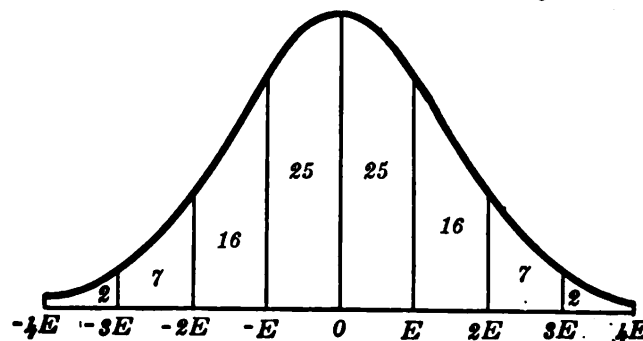

FIG. 146.

strike at any one point, but because of slight discrepancies in aim, powder, atmosphere, etc., they will scatter somewhat. They will, however, cluster about a central point, — "the center of impact," — large errors being few and small errors numerous, in accordance with the Normal Probability Curve (Fig. 146).

The best half of the shots will fall within a certain distance  $E$  ft. of the center, over or short. ( $E$  is called the "probable error" for the gun at the range in question.) All the shots will fall within a distance of  $4E$  from the center, and will in the long run be distributed as in the following table:

50% ZONE								
$-4E$	$-3E$	$-2E$	$-E$	0	$E$	$2E$	$3E$	$4E$
2	7	16	25	25	16	7	2	

PERCENTAGE OF SHOTS FALLING IN EACH ZONE.

$E, 2E, \text{ETC.},$  ARE DISTANCES FROM CENTER OF IMPACT.

*N. B.* If the center is not correctly laid on the target, more than half the shots will be "overs" or "shorts."

With this information an artillery officer can correct his fire. For example, if only 9% of the shots are seen to strike beyond the target, the distance to the target from the center of impact of the shots must be about  $2E$ , which is pretty accurately known for the gun in question, — and the gun is re-aimed accordingly. Similarly if 15% of the shots fall short, the target must be about one third of the way from the  $-2E$  mark to the  $-E$  mark on the scale above; etc.

*Remark.* These percentages, 25, 16, 7, 2, give the distribution not only for errors of artillery fire, but for all sorts of errors of measurement, and also the distribution of many physical characters. This fact is very fundamental in the science of statistics.

### EXERCISES

1. If a gun has a P. E. of 70 m. and the center of impact has been erroneously placed 140 m. beyond the target, find from the table above what percentage of shots will fall short and what percentage will be "overs" in the long run.
2. For the gun in Ex. 1, if 25% of the shots fall short, how far is the target from the center of impact, and in which direction? What if 40% of the shots are shorts?
3. The table shows that the probability of a positive error greater than 3 P. E. on a single shot is about .02. What is the probability that 2 consecutive shots will both have such an error?
4. What is the probability that 3 successive shots will fall short and by less than 1 P. E.?
5. Suppose that the distribution of male statures in a nation follows the normal probability curve, 68 in. being the average stature, and 2 in. the deviation which is exceeded in half the cases. If a man's height is 70 in., what percentage of his compatriots are taller? What if his height is 72 in.? 74 in.? 62 in.?

6. In certain measurements the probability of an error of  $x$  mm. is proportional to  $e^{-x^2}$ . How does the chance for an error of 1 mm. compare numerically with the chance for an error of .5 mm. or .2 mm.?

7. In Ex. 6 what is the probability that two successive measurements will have errors of .5 mm. and .2 mm., as compared with the probability of an error of 1 mm. each time?

§ 342. **Method of Least Squares.** If we measure an object several times, with different results, how shall we know the *most probable size* of the object?

For example, suppose there are to be three measurements, — with some unknown errors  $x_1, x_2, x_3$ . The chance that this particular set of errors will be made is the product of the chances that each error will be made separately, and hence is proportional to

$$p = e^{-nx_1^2} \cdot e^{-nx_2^2} \cdot e^{-nx_3^2}.$$

*I.e.*, adding exponents,

$$p = e^{-n(x_1^2 + x_2^2 + x_3^2)} = \frac{1}{e^{n(x_1^2 + x_2^2 + x_3^2)}}.$$

The most probable set of errors is that for which this  $p$  is largest; and hence that for which

$$x_1^2 + x_2^2 + x_3^2 \text{ is least.}$$

Similarly, in general, *the most probable value of the thing measured is that which would make the sum of the squares of the errors least*, — provided, of course, that the distribution of errors follows the normal probability curve.

Ex. I. The force ( $f$  lb.) required to stretch a wire  $x$  thousandths of an inch varied as in the adjacent table. These values should satisfy an equation of the form

$$f = mx,$$

$x$	$f$
3	20
5	33
11	73

whose graph is a straight line through the origin. But there are slight discrepancies, due to errors of measurement. Find the most probable value of  $m$ .

When  $x=3, 5, 11;$   
the true  $f$  is:  $f=3m, 5m, 11m.$

The errors in the tabulated values of  $f$  are therefore

$$3m-20, \quad 5m-33, \quad 11m-73.$$

The most probable value of  $m$  makes the sum of the squares,

$$S = (3m-20)^2 + (5m-33)^2 + (11m-73)^2,$$

least. Differentiating and equating  $dS/dm$  to zero gives:

$$\frac{dS}{dm} = 2(3m-20)(3) + 2(5m-33)(5) + 2(11m-73)(11) = 0.$$

$$\therefore 155m = 1028, \quad m = 6.63^+.$$

And the most probable values of  $f$  for  $x=3, 5, 11$ , are:

$$f = 3m = 20.0, \quad f = 5m = 33.16, \quad f = 11m = 72.95.$$

**§ 343. Several Coefficients.** In trying to find the most probable "Polynomial Law" for a given table, say

$$y = a + bx + cx^2 + \dots, \quad (14)$$

the sum of the squares of the errors  $S$  is a function of several unknown coefficients,  $a, b$ , etc. For a minimum of  $S$  we set each of its partial derivatives equal to zero (§ 300):

$$\frac{\partial S}{\partial a} = 0, \quad \frac{\partial S}{\partial b} = 0, \quad \text{etc.}$$

$x$	$y$	Ex. I. Find the most probable linear formula $y = a + bx$
10	1.6	for the adjacent table.
20	4.2	For each pair of tabulated values, $a + bx$ should equal $y$ . Any
30	6.6	difference is an error. That is, the errors here are:

$$a + 10b - 1.6, \quad a + 20b - 4.2, \quad \text{etc.}$$

The sum of the squares of the errors is, then,

$$S = (a + 10b - 1.6)^2 + (a + 20b - 4.2)^2 + (a + 30b - 6.6)^2.$$

$$\frac{\partial S}{\partial a} = 2(a + 10b - 1.6) + 2(a + 20b - 4.2) + 2(a + 30b - 6.6).$$

$$\frac{\partial S}{\partial b} = 20(a + 10b - 1.6) + 40(a + 20b - 4.2) + 60(a + 30b - 6.6).$$

Equating these to zero, canceling 2 or 20, and collecting :

$$3a + 60b - 12.4 = 0$$

$$6a + 140b - 29.8 = 0$$

Solving these equations gives  $a = -\frac{1}{3}$ ,  $b = \frac{1}{4}$ .

Hence the most probable law is

$$y = -\frac{1}{3} + \frac{1}{4}x.$$

### EXERCISES

1. Find the most probable value of  $m$  in the formula  $y = mx$  for each of the following tables :

$$(a) \begin{array}{c|c|c|c} x & 5 & 10 & 20 \\ \hline y & 4 & 8 & 17 \end{array}, \quad (b) \begin{array}{c|c|c|c} x & 1 & 3 & 5 \\ \hline y & 7.5 & 22.4 & 37.8 \end{array}$$

2. The following elongations of a rod should, if strictly accurate, vary with the stretching force according to the formula  $e = kF$ .

$$(a) \text{ Find the most probable value of } k. \begin{array}{c|c|c|c} F & 5000 & 10000 & 15000 \\ \hline e & .231 & .465 & .691 \end{array}$$

(b) Using your value of  $k$ , calculate  $e$  from the formula when  $F = 5000$ , etc., and compare the table.

3. Find the most probable values for  $a$  and  $b$  in the formula  $y = ax + b$  for each of these tables :

$$(a) \begin{array}{c|c|c|c} x & 10 & 20 & 30 \\ \hline y & 5.1 & 6.9 & 9.1 \end{array}, \quad (b) \begin{array}{c|c|c|c} x & 2 & 5 & 10 \\ \hline y & .59 & 3.01 & 7.00 \end{array}$$

4. The weight of common salt which will dissolve in 100 g. of water at various temperatures is shown in the following table. Find the most probable linear formula,  $W = aT + b$ .

$$\begin{array}{c|c|c|c|c|c} T & 0 & 10 & 30 & 50 & 100 \\ \hline W & 35.7 & 35.8 & 36.3 & 37.0 & 39.8 \end{array}$$

5. The height of a desk was measured, with the same care each time, as 20 in., 20.2 in., 20.1 in., and 19.9 in. What is the most probable height,  $x$  in.? [Show that your result is the arithmetical average.]

§ 344. **Summary of Chapter XIV.** The formula for the number of combinations of  $n$  things taken  $r$  at a time is derived from the formula for the number of arrangements. Besides its more important uses, it enables us to write the binomial theorem for integral exponents in a new way.

The foregoing problems in permutations and combinations are confined to the simplest cases. And we have had only a glimpse of probabilities and the method of least squares, both of which are very fundamental in the study of statistics. But even this glimpse may serve as an introduction, and familiarize us with the idea of Normal Binomial Distributions and the Normal Probability Curve for chance events.

To round out our knowledge of the number system of algebra, and of the use of "imaginaries" in studying certain kinds of variation, we shall conclude the course with a brief study of "Complex Numbers."

## EXERCISES

1. How many baseball batting-orders are obtainable in choosing a nine from 15 sailors and 20 soldiers so as to contain 3 sailors and 6 soldiers, if the sailors are to bat before the soldiers?

2. If 10 cards are drawn at random from a pack, what is the chance for precisely 3 spades? Show that your result is reasonable.

3. What is the probability that the first shot from a gun will go over the target by more than 2 P. E. and the second fall short by more than 1 P. E. if the center of impact is correctly placed on the target?

4. The weight of silver nitrate which will dissolve in 100 g. of water at various temperatures is shown here. Find the most probable linear formula.

$T$	0	20	50	80
$W$	122	222	455	669

5. By Weber's law in psychology we should have in the adjacent table:  $\Delta i = mi$ . [Here  $\Delta i$  is the smallest increase in the intensity  $i$  of a light which a certain observer could detect.] Find the most probable value of  $m$ .

$i$	25	60	120	300
$\Delta i$	.2	.5	.8	2.5

6. In studying the relation of a firm's advertising expenditure and volume of business, it was necessary to find the most probable linear formulas for  $\bar{y}$  and  $\bar{x}$  in these tables:

$x$	2	4	6	8
$\bar{y}$	60	68	75	84

$y$	60	80	100	120
$\bar{x}$	2	3.6	5.3	6.8

The index of correlation is  $(d\bar{y}/dx) \cdot (d\bar{x}/dy)$ . Find this.

## CHAPTER XV

### COMPLEX NUMBERS

#### OPERATIONS WITH DIRECTED QUANTITIES

§ 345. **The Real Number System.** Elementary arithmetic deals only with positive numbers, — running from zero upward. In algebra we invent another set of numbers, — “negative numbers,” — running from zero downward.

In arithmetic it is impossible to subtract 7 from 5, or 9 from 0, or any other number from a smaller one. In algebra this is possible:  $5-7$  gives simply  $-2$ ; etc. The introduction of negative numbers makes subtraction possible in all cases.

Still more important, the complete set of positive and negative numbers is adapted to the study of *opposite quantities*, such as temperatures above and below zero, elevations above and below sea-level, latitudes north and south, gains and losses, etc.

The complete set of positive and negative numbers is called the Real Number System.

The positive numbers can be represented by the points of a line in one direction from a chosen point or origin; the complete set of positive and negative numbers by all the points of a line, in both directions from the origin or zero point.

Students just beginning algebra sometimes wonder how negative numbers are possible. Can there be any number lower than zero? Not if we are thinking of numbers as in arithmetic. But this is just the point: In algebra we are talking about a *new kind* of number. But are not such numbers purely fictitious or abstract? Yes, until we exhibit some concrete interpretation for them, — some definite set



of objects to which they can be applied, such as temperatures below zero, etc.

To deal with negative numbers, certain rules of operation are agreed upon, such as  $(-)\times(-)=(+)$ , etc. These, while arbitrary, are justified by the useful way in which the rules work. The same will be true of what we shall say about "imaginary numbers."

(Of course, in inventing any new kind of number, we have a right to prescribe the rules of combination, — just as the inventor of any game, such as chess, had the right to specify how the "pieces" should move.)

**§ 346. "Imaginary" Numbers.** In elementary algebra, as long as we know only the real number system, it is impossible to solve the equation  $x^2 = -4$ . For the square of any real number, positive or negative, is positive, and hence never  $-4$ .

But we can solve this and similar equations by inventing a still different set of numbers called *imaginary* or *complex* numbers. We may do this as follows:

Let  $i$  denote a number whose square is  $-1$ , that is,

$$i^2 = -1, \text{ or } i = \sqrt{-1}. \quad (1)$$

And let  $-i$  denote the result of subtracting  $i$  from zero; that is,  $(-i) = 0 - (i)$ . Squaring shows that  $(-i)^2 = i^2 = -1$ . Thus there are two numbers,  $i$  and  $-i$ , whose square equals  $-1$ . So  $-1$  has two square roots,  $i$  and  $-i$ . We shall denote either by  $\sqrt{-1}$ .

Observe that  $i$  and  $-i$  are not "real" numbers; and are not to be regarded as positive or negative, greater or less than zero. They are, however, opposites.

With the introduction of the "imaginary unit"  $i$ , and multiples of  $i$ , we can extract the square root of any negative number. *E.g.*,

$$\begin{aligned} \sqrt{-4} &= \sqrt{4}\sqrt{-1}, &= 2i, \text{ or } -2i. \\ \sqrt{-13} &= \sqrt{13}\sqrt{-1}, &= \sqrt{13}i, \text{ or } -\sqrt{13}i. \end{aligned}$$

In fact, by using combinations of real and imaginary units, such as  $3+2i$ ,  $7-6i$ , etc., it is possible to extract the square root, or any other root, of any real or complex number.

For instance:  $\sqrt{7-24i} = 4-3i$  or  $-4+3i$ . This may be verified by squaring either result.

Indeed, the number system composed of all possible combinations, such as  $a+bi$ , where  $a$  and  $b$  are any real numbers, suffices for all the purposes of ordinary algebra.

**§ 347. Operations.** We agree that complex numbers shall be combined according to the usual rules of algebra, multiplying sums term by term, adding like terms, etc.

For instance :

$$\begin{aligned}(2+3i) + (5+8i) &= 7+11i \\ (2+3i)(5+8i) &= 10+15i+16i+24i^2\end{aligned}$$

Since  $i^2 = -1$ , this last reduces to  $-14+31i$ .

To perform a division, we first indicate the result as a fraction, and then rationalize the denominator. If the denominator is  $a+bi$  we have simply to multiply above and below by  $a-bi$ .

For instance :

$$\begin{aligned}(2+3i) \div (5+8i) &= \frac{2+3i}{5+8i} = \frac{(2+3i)(5-8i)}{(5+8i)(5-8i)} \\ &= \frac{34-i}{5^2-(8i)^2} = \frac{34}{89} - \frac{1}{89}i.\end{aligned}$$

In this way, the quotient of any two complex numbers is reducible to the standard form of a complex number,  $c+di$ . (How could any division be checked?)

**THEOREM.** *Two complex numbers can be equal only if their real parts are equal, and also their imaginary parts.*

For instance, if  $x+yi=3+4i$ , then  $x=3$  and  $y=4$ . For  $x-3=(4-y)i$ , and if both sides were not zero, we should have a real number equal to an imaginary.

To extract a square root, denote the required root by  $a+bi$ . Then square, and compare with the given number.

For instance, let us find  $\sqrt{7-24i}$ ,  $=a+bi$ , say.

Squaring:  $7-24i = a^2 + 2abi + b^2i^2$ . Equating real parts, and also imaginary parts:  $a^2 - b^2 = 7$ ,  $2ab = -24$ . Solving gives  $a = \pm 4$ ,  $b = \mp 3$ .

$$\therefore \sqrt{7-24i} = 4-3i, \text{ or } -4+3i.$$

### EXERCISES

1. Perform these additions and subtractions, and simplify:

- (a)  $(4+3i) + (9+i)$ , (b)  $(7+6i) - (2+8i)$ ,  
 (c)  $(-6-8i) + (4-3i)$ , (d)  $(-3+2i) - (-9-11i)$ .

2. Perform these multiplications and divisions, in each case reducing the result to the standard form  $x+yi$ :

- (a)  $(7+4i)(12-2i)$ , (b)  $(5-i) \div (3-2i)$ ,  
 (c)  $(-1+13i)i$ , (d)  $(-1+13i) \div i$ ,  
 (e)  $(3+5i)(i^3-i^2)$ , (f)  $7 \div (8+5i)$ ,  
 (g)  $(2-i)^3$ , (h)  $i \div (6i-4)$ .

3. Find two square roots for each of the following:

- (a)  $4+3i$ , (b)  $4-3i$ , (c)  $-4+3i$ , (d)  $-3-4i$ ,  
 (e)  $5-12i$ , (f)  $-12-5i$ , (g)  $15+8i$ , (h)  $-8-15i$ ,  
 (i)  $40+9i$ , (j)  $16-63i$ , (k)  $-21+20i$ , (l)  $-11-60i$ .

### § 348. Geometrical Representation of Complex Numbers.

In any given plane let a pair of rectangular coördinate axes  $OX$  and  $OY$  be selected.

And let any complex number  $x+yi$  be represented by the directed line, or "vector,"  $OP$  drawn from the origin  $O$  to the point  $P$  whose coördinates are  $x$  and  $y$ .

*E.g.*, the number  $-3+4i$  is represented by the vector from  $O$  to the point  $(-3, 4)$ . Observe that it

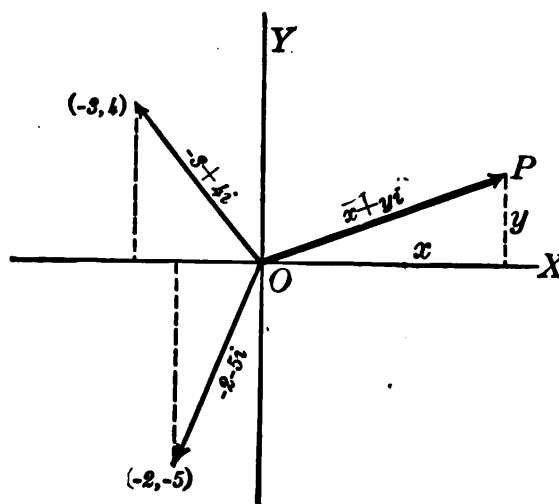

FIG. 147.

is not the *length* of the vector (viz., 5) which represents the complex number, but rather the *vector itself*, — i.e., the directed line.

The length of the vector  $OP$  is called the absolute value or numerical value of the number  $x+yi$ , written  $|x+yi|$ . Thus

$$\text{Num. value of } x+yi = |x+yi| = \sqrt{x^2+y^2}. \quad (2)$$

Observe that when we say that the numerical value of  $-3+4i$  is  $\sqrt{(3)^2+(4)^2}=5$ , we are not saying that  $-3+4i=5$ . The numerical value of  $-10$  is 10, but  $-10$  does not equal 10.

With this representation of a complex number, let us see what will represent the *sum* of two such numbers. We have agreed that

$$(x+yi) + (x'+y'i) = (x+x') + (y'+y)i. \quad (3)$$

Hence the vector representing the sum should run from  $O$  to the point whose coördinates are  $(x+x', y+y')$ .

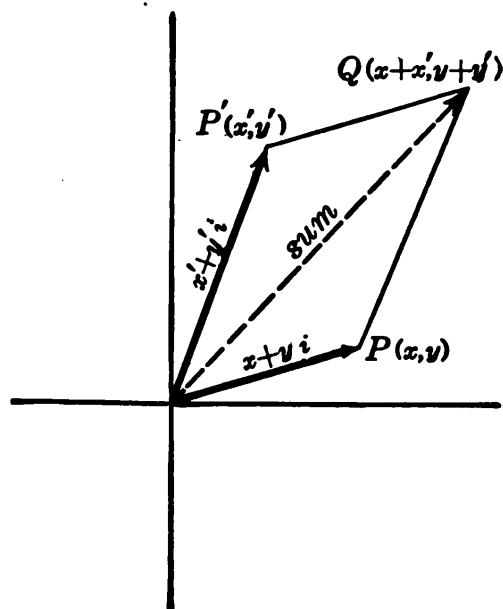

FIG. 148.

number than the “real” numbers whose vectors all lie along the X-axis.

In other words, to add two complex numbers graphically, proceed just as in finding the combined effect of two forces which act from a common point. Make a parallelogram.

*Remark.* Such vectors, combined in this way, have all the properties of complex numbers. Hence to picture to yourself what sort of thing an “imaginary” number is, simply think of these directed lines. Thus a complex number is not something vague and impossible of existence in a real world. It is simply a more general kind of

§ 349. **Polar Form of a Complex Number.** In the form  $x + yi$ , a complex number is expressed in terms of the rectangular coördinates  $x$  and  $y$  of the end of its vector. For many purposes it is better expressed in terms of the polar coördinates  $(r, \theta)$  of that point. (Fig. 149.)

Clearly  $x = r \cos \theta$ ,  $y = r \sin \theta$ , hence

$$x + yi = r (\cos \theta + i \sin \theta). \quad (4)$$

This latter is called the "polar form" of the complex number. As before,  $r$  is called the *absolute value* of the number;  $\theta$  is called the *argument* or simply the angle.

$\cos \theta + i \sin \theta$  is often abbreviated *cis*  $\theta$ . Thus

$$x + yi = r \text{ cis } \theta. \quad (5)$$

To change easily from the rectangular to the polar form, or *vice versa*, simply draw the vector; and calculate the required values of  $(r, \theta)$  or  $(x, y)$  from the figure. This is exceedingly important and should be practiced freely.

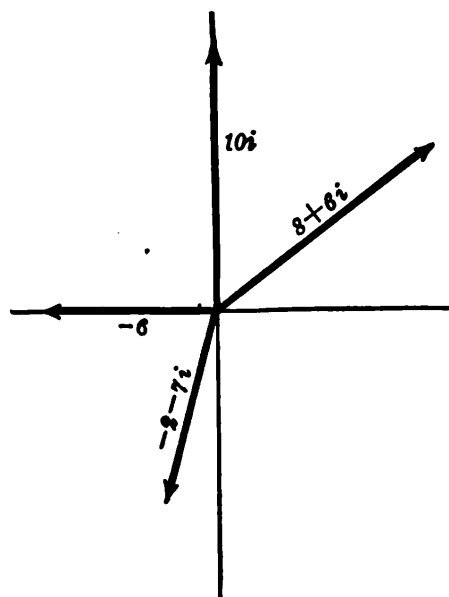

FIG. 150.

Ex. I. Find the polar forms for  $8 + 6i$ ;  $-2 - 7i$ ;  $-6$ ;  $10i$ . Fig. 150 shows the vectors representing these numbers.

(1) Here  $r = \sqrt{8^2 + 6^2} = 10$ ;  $\tan \theta = \frac{6}{8}$ ,  $\theta = 36^\circ 52'$

$$\therefore 8 + 6i = 10(\cos 36^\circ 52' + i \sin 36^\circ 52') = 10 \text{ cis } 36^\circ 52'.$$

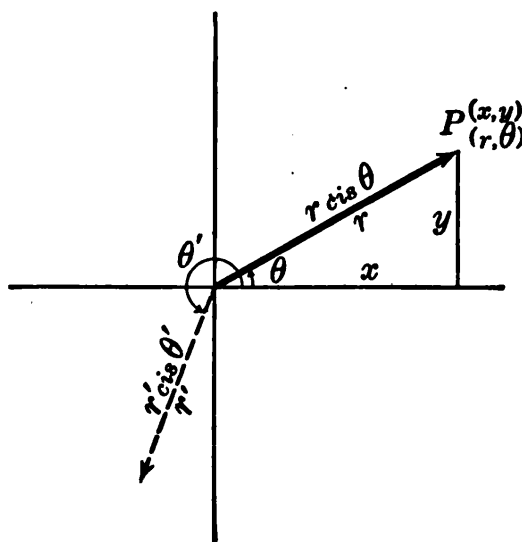

FIG. 149.

(2) Here  $r = \sqrt{(-2)^2 + (-7)^2} = \sqrt{53}$ ,  $\tan \theta = -7/-2$ ,  $\theta = 180^\circ + 74^\circ 3'$ .  
 $\therefore -2 - 7i = \sqrt{53} \operatorname{cis} 254^\circ 3'$ .

(3) Here, by inspection,  $r = 6$ ;  $\theta = 180^\circ$ .  
 $\therefore -6 = 6(\cos 180^\circ + i \sin 180^\circ) = 6 \operatorname{cis} 180^\circ$ .

(4) Here, by inspection,  $r = 10$ ;  $\theta = 90^\circ$ .  
 $\therefore 10i = 10(\cos 90^\circ + i \sin 90^\circ) = 10 \operatorname{cis} 90^\circ$ .

## EXERCISES

1. Mark the points and draw the vectors representing these numbers :

$$\begin{array}{cccc} -5i, & 4+6i, & -3-7i, & -9, \\ 3.5i, & 9-2i, & -1+i, & +2. \end{array}$$

2. Perform the following additions algebraically, and also geometrically by means of the vectors representing the given numbers :

$$\begin{array}{ll} (a) (4+2i) + (2+7i), & (b) (8+5i) + (1-9i), \\ (c) (6+i) + (-7+4i), & (d) (3+11i) + (-3-2i), \\ (e) (9-5i) + (3i), & (f) (-24) + (-6i). \end{array}$$

3. Draw the vector representing each of the following numbers, find its  $r$  and  $\theta$ , and re-write the number in polar form :

$$\begin{array}{lll} (a) 2+2i, & (b) -2-2i, & (c) 3i, \\ (d) 3-4i, & (e) -4\sqrt{3}+4i, & (f) -10i, \\ (g) -3, & (h) -4\sqrt{3}-4i, & (i) +12. \end{array}$$

What are some of the different values of  $\theta$  which can be chosen in  $c, f, g, i$  if we do not limit the size of  $\theta$ ?

4. Draw the vector for each of the following, find the  $x$  and  $y$  belonging to the number, and re-write the number in the form  $x+yi$ .

$$\begin{array}{llll} (a) 2 \operatorname{cis} 70^\circ, & (b) 5 \operatorname{cis} 310^\circ, & (c) .3 \operatorname{cis} 180^\circ, & (d) 7 \operatorname{cis} 270^\circ, \\ (e) 12 \operatorname{cis} 240^\circ, & (f) 8 \operatorname{cis} 495^\circ, & (g) 9 \operatorname{cis} 0^\circ, & (h) .4 \operatorname{cis} 720^\circ. \end{array}$$

5. Plot, and find the standard polar form for these numbers :

$$(a) \cos 80^\circ - i \sin 80^\circ, \quad (b) -8 \operatorname{cis} 40^\circ, \quad (c) -10(\cos 50^\circ + i \sin 20^\circ).$$

§ 350. **Multiplication and Division, in Polar Form.** Any two complex numbers can be expressed in the form :

$$r (\cos \theta + i \sin \theta), \quad r' (\cos \theta' + i \sin \theta').$$

Multiplying these together will give

$$rr' [(\cos \theta \cos \theta' - \sin \theta \sin \theta') + i (\sin \theta \cos \theta' + \cos \theta \sin \theta')].$$

But by the Addition Formulas of Trigonometry (§ 281), the first parenthesis is  $\cos (\theta + \theta')$ , and the second is  $\sin (\theta + \theta')$ . Hence the product above reduces to

$$\begin{aligned} & rr' [\cos (\theta + \theta') + i \sin (\theta + \theta')]. \\ \therefore & r \operatorname{cis} \theta \cdot r' \operatorname{cis} \theta' = rr' \operatorname{cis} (\theta + \theta'). \end{aligned} \quad (6)$$

That is, to multiply two complex numbers, *multiply their absolute values and add their angles*. To divide, simply reverse this process. (If the numbers are given in the form of  $x + yi$ , first put them into the polar form.)

Ex. I. Multiplying  $5 \operatorname{cis} 300^\circ$  by  $7 \operatorname{cis} 40^\circ$  gives  $35 \operatorname{cis} 340^\circ$ , *i.e.*,  $(35 \cos 340^\circ) + (35 \sin 340^\circ)i$ , or  $11.97 - 32.89i$ .

Ex. II. Find  $x = (2 \operatorname{cis} 15^\circ)^{10}$ .

For this repeated multiplication, we keep on multiplying the  $r$ 's and adding the  $\theta$ 's, until we finally get

$$x = 2^{10} \operatorname{cis} 150^\circ = 1024(-.866 + .500i) = -867 + 512i.$$

*Remark.* By § 320,  $\cos \theta + i \sin \theta = e^{i\theta}$ , ( $\theta$  in radians).

Hence equation (6) above may be written:

$$re^{i\theta} \cdot r'e^{i\theta'} = rr' \cdot e^{i(\theta + \theta')}$$

In other words, this shows that the usual law for exponents in multiplying holds good even when the exponents are pure imaginaries,  $i\theta$  and  $i\theta'$ .

### EXERCISES

1. Find the following products and quotients, expressing the results in both the polar and rectangular forms, and drawing the various vectors involved:

- (a)  $10 \operatorname{cis} 30^\circ \times 3 \operatorname{cis} 20^\circ$ ,                      (b)  $10 \operatorname{cis} 30^\circ \div 3 \operatorname{cis} 20^\circ$ ,
- (c)  $2 \operatorname{cis} 110^\circ \times 5 \operatorname{cis} 250^\circ$ ,                      (d)  $.6 \operatorname{cis} 110^\circ \div .02 \operatorname{cis} 250^\circ$ ,
- (e)  $(2 \operatorname{cis} 50^\circ)^2$ ,                                      (f)  $-7i \div 2 \operatorname{cis} 100^\circ$ ,
- (g)  $(5 \operatorname{cis} 20^\circ)^3 \times 2i$ ,                              (h)  $(3 \operatorname{cis} 200^\circ)^2 \div (2 \operatorname{cis} 62^\circ)^5$ .

2. Calculate  $x = 3(\cos 20^\circ - i \sin 20^\circ) \div 4 \operatorname{cis} 70^\circ$ .

(The dividend is not in standard form: consider its vector.)

3. Calculate  $x = 20 / (6 \text{ cis } 50^\circ)$ .

(The vector for 20 has  $\theta = 0^\circ$  or  $360^\circ$ , etc. Which is best here?)

[4.] Can you find a number whose cube is  $8 \text{ cis } 30^\circ$ ?

§ 351. **Powers and Roots.** From (6) it follows that for any positive integral value of  $n$ :

$$(r \text{ cis } \theta)^n = r^n \text{ cis } n\theta.$$

Thus we can very quickly find any high power of a complex number which is given in the polar form.

This same idea furnishes a means of *extracting any root* of a complex number.

ILLUSTRATION. Find  $x = \sqrt[3]{7 \text{ cis } 300^\circ}$ .

Let us denote any possible value of  $x$  by  $r \text{ cis } \theta$ :

$$r \text{ cis } \theta = \sqrt[3]{7 \text{ cis } 300^\circ}.$$

Cubing:  $r^3 \text{ cis }^3 \theta = 7 \text{ cis } 300^\circ$ .

This equation is satisfied by  $r = \sqrt[3]{7}$  and  $\theta = 100^\circ$ .

$\therefore \sqrt[3]{7 \text{ cis } 300^\circ} = \sqrt[3]{7} \text{ cis } 100^\circ = -.332 + 1.884 i$ , approximately.

This, however, is not the only possible cube root of the given number. For adding any multiple of  $360^\circ$  to the given angle would not change the value of its sine or cosine; and thus the given number could have been written in any of the forms:

$$7 \text{ cis } 300^\circ, 7 \text{ cis } 660^\circ, 7 \text{ cis } 1020^\circ, 7 \text{ cis } 1380^\circ, \dots$$

The cube roots obtained from these would be

$$\sqrt[3]{7} \text{ cis } 100^\circ, \sqrt[3]{7} \text{ cis } 220^\circ, \sqrt[3]{7} \text{ cis } 340^\circ, \sqrt[3]{7} \text{ cis } 460^\circ, \dots$$

The last of these equals the first, however. And further forms would only repeat some of the first three.

Thus,  $7 \text{ cis } 300^\circ$  has three cube roots which are distinct, — and no more.

In getting  $r$  there is no ambiguity. For  $r$  is real, and 7 has only one *real* cube root.



In general there are  $n$  distinct  $n$ th roots of any number, real or imaginary. They can be found by expressing the given number in the several polar forms :

$$r \operatorname{cis} \theta, \quad r \operatorname{cis} (\theta + 360^\circ), \quad r \operatorname{cis} (\theta + 720^\circ), \quad \dots,$$

and then extracting the  $n$ th root of  $r$  and dividing each angle by  $n$ .

Further illustrations follow.

**Ex. I.** Find the fourth roots of  $z = 81 \operatorname{cis} 20^\circ$ .

The given number  $z$  may also be written :

$$\begin{aligned} z &= 81 \operatorname{cis} 380^\circ, \quad 81 \operatorname{cis} 740^\circ, \quad 81 \operatorname{cis} 1100^\circ, \quad \dots \\ \therefore \sqrt[4]{z} &= 3 \operatorname{cis} 5^\circ, \quad 3 \operatorname{cis} 95^\circ, \quad 3 \operatorname{cis} 185^\circ, \quad 3 \operatorname{cis} 255^\circ. \end{aligned}$$

**Ex. II.** Find the square roots of  $i$ .

Proceeding as in § 349, we express  $i$  in the form

$$\begin{aligned} i &= \operatorname{cis} 90^\circ, & \text{or } \operatorname{cis} 450^\circ, & \dots \\ \therefore \sqrt{i} &= \operatorname{cis} 45^\circ, & \text{or } \operatorname{cis} 225^\circ, & \dots \end{aligned}$$

That is, since  $\sin 45^\circ$  and  $\cos 45^\circ$  are both  $\frac{\sqrt{2}}{2}$  (by geometry),

$$\therefore \sqrt{i} = \frac{\sqrt{2}}{2}(1+i), \quad \text{or } \frac{\sqrt{2}}{2}(1-i). \quad (\text{Check?})$$

### EXERCISES

1. Verify that squaring either answer to Ex. II above will give  $i$ .
2. Find the following roots (all values of each) :  
 (a)  $\sqrt[6]{27 \operatorname{cis} 120^\circ}$ , (b)  $\sqrt[4]{16 \operatorname{cis} -60^\circ}$ , (c)  $\sqrt[10]{32 \operatorname{cis} 280^\circ}$ ,  
 (d)  $\sqrt[3]{-8i}$ , (e)  $\sqrt{9(\cos 80^\circ - i \sin 80^\circ)}$ , (f)  $\sqrt[5]{\cos 10^\circ - i \sin 10^\circ}$ .
3. Find the five fifth-roots of  $-1$ ; and express numerically in the  $x+yi$  form by trigonometric tables. (Hint: What is the polar form for  $-1$ ?)
4. Find the three cube roots of  $+1$ , and plot roughly the points representing them. Where do those points lie?
5. The same as Ex. 4 for the four fourth-roots of  $+1$ .

**§ 352.  $n$ th Roots of Unity.** The  $n$ th roots of the number  $+1$  are interesting, and, in Higher Algebra, very important. Let us consider first the *sixth* roots.

Expressed in the polar form,

$$1 = \text{cis } 0^\circ, \quad \text{cis } 360^\circ, \quad \text{cis } 720^\circ, \quad \text{cis } 1080^\circ, \quad \text{etc.},$$

$$\therefore \sqrt[6]{1} = \text{cis } 0^\circ, \quad \text{cis } 60^\circ, \quad \text{cis } 120^\circ, \quad \text{cis } 180^\circ, \quad \text{etc.}$$

The vectors representing these sixth roots all have  $r=1$ , and their successive angles differ by  $60^\circ$ . Hence their ends lie on a circle of unit radius, and are vertices of a regular inscribed hexagon.

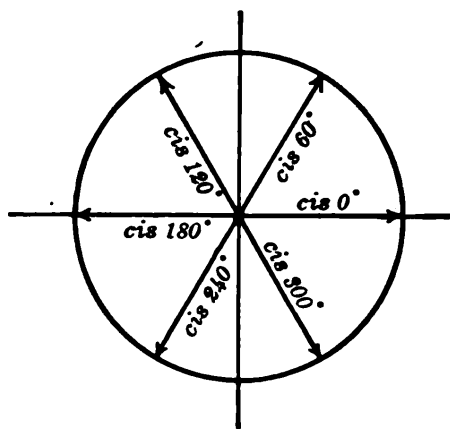

FIG. 151.

Similarly the  $n$ th roots of  $+1$  are represented by vectors drawn to the vertices of a regular inscribed  $n$ -gon.

The  $n$ th roots of any number other than 1 would be represented by vectors to the vertices of a regular  $n$ -gon inscribed in some circle perhaps of a different radius, and the first vertex being perhaps at some point off the real axis.

### EXERCISES

1. Find the following  $n$ th roots and mark the  $n$  points representing them in each case:

(a) $\sqrt[4]{1}$ ,	(b) $\sqrt[8]{-1}$ ,	(c) $\sqrt[12]{1}$ ,
(d) $\sqrt[5]{1}$ ,	(e) $\sqrt[10]{1}$ ,	(f) $\sqrt[3]{-1}$ ,
(g) $\sqrt[4]{-1}$ ,	(h) $\sqrt[3]{-i}$ ,	(i) $\sqrt[4]{i}$ .

2. The same as Ex. 1 for the following:

(a) $\sqrt[3]{27} \text{cis } 60^\circ$ ,	(b) $\sqrt[4]{9} \text{cis } 140^\circ$ ,	(c) $\sqrt{4} \text{cis } 320^\circ$ .
---	---	--

3. In Ex. 1 (a), (b) show graphically and also by calculation that the sum of all the  $n$  roots is zero.

4. In what further parts of Exs. 1–2 is the sum of the roots zero?

**§ 353. Application to Electricity.** In studying electricity, it is customary to represent a simple alternating current by a vector in the “complex plane.” The length of the vector represents the maxi-

imum intensity of the current and the angle of the vector represents the time during the periodic oscillation when that maximum is reached.

It can be proved that if a circle be drawn on the said vector as diameter, and a varying vector be drawn from the origin to the circle, the latter vector as it turns will represent the varying intensity of the current during the entire period of oscillation.

Moreover, if another current, represented by any other vector at right angles to the first, is also impressed upon the same circuit, the resulting combination current will be represented by the resultant (or sum) of the two vectors.

These facts and others, together with the laws of imaginary numbers, make such numbers exceedingly useful in the study of alternating currents, and they are discussed at length in treatises on that subject.

**§ 354. Summary of Chapter XV.** The number system of elementary arithmetic consists solely of real positive numbers, representable by points on a line in one direction from a chosen origin. The complete number system of algebra consists of: (I) All real numbers, representable by all the points along a line or all vectors drawn from the "origin" to those points; (II) All pure imaginaries, representable by vectors to all points on another line perpendicular to the first; (III) All complex numbers (combinations of reals and pure imaginaries) and representable by vectors to all points in the plane.\*

The so-called "imaginary" numbers are susceptible of concrete interpretation, and become very useful in electrical engineering and elsewhere.

The rectangular form  $x+yi$  is best for addition and subtraction; the polar form  $r(\cos \theta + i \sin \theta)$  for finding powers and roots. Either is good for simple multiplications or divisions.

There are  $n$  distinct  $n$ th roots of any number. The two square roots (+ or -) as found in elementary algebra are merely a special case of this.

\* Strictly speaking, (III) includes (I) and (II).

## EXERCISES

1. Carry out these calculations, marking the points and getting the results in both polar and rectangular form :

- |  |   |
|--|---|
| (a) $(3+6i) + (5-4i)$ ,  | (b) $(3+6i) \div (5-4i)$ ,  |
| (c) $2 \operatorname{cis} 60^\circ \times 5 \operatorname{cis} 90^\circ$ , | (d) $8 \operatorname{cis} 120^\circ \div 3 \operatorname{cis} 40^\circ$ , |
| (e) $(7 \operatorname{cis} 28^\circ)^3$ ,                                  | (f) $\sqrt[4]{16 \operatorname{cis} 320^\circ}$ .                         |

## Retrospect and Prospect

We have now considered some of the more important problems relating to variation and the mutual dependence of quantities; and have developed methods of dealing with these problems, at least in the simpler cases.

Most of the mathematical processes covered here and in more elementary courses originated in the effort to solve certain practical problems. For instance, geometry developed out of problems of mensuration, trigonometry from problems of surveying, and algebra from the attempt to systematize certain kinds of calculations. The basic problem of differential calculus is to find the rate at which some quantity will vary with some other quantity on which it depends. Integral calculus seeks to determine how large a varying quantity will be at any time, knowing its present size and its rate of increase at all times. Or, what amounts to the same thing, to find the sum of all infinitesimal elements of a quantity, knowing how each element that we add will vary in size. It would be hard to think of any problem of science or business which is more common or more important than these. Moreover, the calculus methods of analysis, — once they are thoroughly understood and have become a habit of thought, — are invaluable in analyzing new problems on variation or summation.

As yet, however, we are only on the threshold of Mathematics. We have differentiated only the most elementary

functions, — trigonometric, logarithmic, exponential, and power functions, and simple combinations of these. There are many other types of functions, relating to important kinds of variation, not discussed in this course. The study of their differentiation, integration, and application makes calculus a vastly bigger subject than the very brief introduction given in this course might suggest.\*

Analytic geometry also is an exceedingly extensive subject. Besides rectangular and polar coördinates, numerous other systems of coördinates have been invented, especially for studying geometry upon various kinds of surfaces. There is scarcely any limit to the variety of curves and surfaces whose geometrical properties have been, and are being, investigated analytically. Then, too, there are the *non-euclidean* geometries, and the geometry of *hyperspace* or  $n$  dimensions. And in modern times new methods of investigation, of a purely geometrical character (“projective” methods), have led to many beautiful theorems concerning triangles, circles, and other figures.

Algebra, too, has many higher branches, — dealing with number relations, the solution of equations, the simplification of expressions by algebraic substitutions, infinite series, etc. Further kinds of numbers, which combine according to different laws even than the “imaginary numbers,” have also been invented and studied.

In fact, the science of Mathematics has in modern times

\* There is in fact no limit to the possible variety of functions, for a quantity may vary with another in any manner whatever. Hence if we state simply that  $y$  is a function of  $x$ , all we are saying is that *To every value of  $x$  there corresponds a value (or values) of  $y$ , according to some definite law or system or agreement.*

*E.g.*, the postage on a letter is a function of the weight. For any weight up to 1 oz., the postage is 2¢. For any weight from 1 oz. up to 2 oz., the postage is 4¢, jumping instantly from 2¢ to 4¢ as soon as the weight passes an exact ounce. And so on. This is a very peculiar type of function, represented graphically by a series of horizontal lines, entirely separated.

grown to such vast proportions that no one can now hope to have a detailed knowledge of the whole field. Moreover it is still growing, and more rapidly than ever. Hundreds of research papers are published each year developing new processes and announcing theorems previously unknown.

Much of this higher mathematics is very abstract. But it is not therefore valueless, even from the standpoint of applications. Several subjects which originally developed in a theoretical way with no thought of a practical application have later been taken over bodily by some practical science, *e.g.*, electrical engineering, crystallography, etc. Several others have contributed powerful methods to the solution of particular problems. The theoretical mathematics of to-day may be practical mathematics to-morrow.

But this is only one aspect of the matter. The intellectual values obtainable from a contemplation of the power, elegance, and absolute precision of mathematical reasoning, and of the perfect harmony existing among the various branches, are very great indeed. In elementary courses, — such as this, and those immediately following, — which are designed for all classes of students, the practical aspects deserve particular emphasis. But men and women who have time to get an understanding of the more advanced branches find nothing finer and more inspiring than the wonderfully abstruse investigations of pure mathematics, — *achievements of the reason which far transcend the realms of physical sense, and time and space.*

## GENERAL REVIEW

### Exercises on Chapters I-VI

1. In a series of experiments the yield of various crops ( $Y$  bushels per acre) was found to vary with the amounts ( $F$  lb.) of nitrate fertilizer used as shown in the table. Plot the graph. Apparently, what  $F$  gives the maximum  $Y$ ?

$F$	$Y$
0	16
80	24
160	28
240	24
320	21

2. Differentiate:  $y = x^4 - \frac{7x^2}{3} - 6\sqrt[3]{x} + \frac{5}{6-x^2} + (x^4+1)^{\frac{5}{3}} + 7\sqrt{11}$ .

Integrate:  $\int \left[ x^8 - 24x + 19 - \frac{12}{x^3} + \frac{4}{\sqrt{x}} \right] dx$ . ✓

3. The load ( $L$  lb.) per sq. ft. on a certain rectangular floor varies, being  $L = (x-15)^2$  at a distance of  $x$  ft. from one end. (a) Find the total load on the floor, if the length is 30 ft. and the width is 20 ft. (b) Explain in what sense we can say that "the load per sq. ft. is 100 lb. at a distance of 5 ft. from one end," — in view of the fact that a square foot of floor cannot all be at exactly that distance.

4. A cable car weighing 13975 lb. stands on an incline whose grade is 60 per cent. How hard does it press against the rails, and what is the pull in the cable, ignoring friction?

5. A plane inclined  $29^\circ 41'$  passes through a diameter of the base of a cylinder of radius 9 in. (a) Find the area and greatest length of the sloping section. (b) Find the volume of the wedge cut off.

6. The force applied to an object varied thus:  $F = 45t^2 - t^3$ . Find the momentum imparted from  $t=0$  to  $t=40$ . When was the force increasing most rapidly? What was the maximum force?

7. Plot the force in Ex. 6 as a function of  $t$ , and check your answers graphically.

8. A cylindrical tank is to contain 1125 cu. ft. and is to have a hemispherical screen for a roof. If the bottom costs 40 cents per sq. ft., the curved wall 30 cents per sq. ft., and the roof 20 cents per sq. ft., find the least possible total cost.

9. For a quantity of gas:  $v = 6000/p$ . If  $p$  is increasing at the rate of .2 unit per min., how fast is  $v$  changing, when  $p = 20$ ?

10. To find the distance from a gun  $G$  to a target  $T$  a line  $GP = 428.5$  yd. was laid off and angles measured as follows:  $TGP = 68^\circ 15'.6$ ,  $TPG = 101^\circ 12'$ . Find  $GT$ .

11. A triangular farm lies at the junction of two rivers having a frontage of 780 yd. on one and 930 yd. on the other. Its area is 291000 sq. yd. Tell precisely what steps you would take to calculate the angle between the rivers, and the length of fence required for the third side of the farm. Mention any formulas needed.

12. Calculate:  $x = \pi \sqrt{\frac{38764.(-.09627)^2 \sqrt[3]{-.2}}{-198.98}}$

✓ 13. A bullet was fired straight up from an airplane 6000 ft. high, with an initial velocity of 2000 ft./sec. Find its height at any time. When was it highest and when down to earth?

✓ 14. A cylindrical tank of radius 4 ft. lies horizontally, and is half full of oil weighing 60 lb. per cu. ft. Find the pressure on one of its circular ends.

15. The adjacent table shows the angular velocity ( $\omega$  deg./sec.) of a flywheel of radius 10 ft. at various times ( $t$  sec.). Find the angular acceleration when  $t=100$ , and the total angle turned from  $t=0$  to  $t=180$ .

$t$	$\omega$
0	0
30	240
60	840
90	1620
120	2400
150	3000
180	3240

16. What measurements of lines and angles made on one side of a river would suffice to let us find the distance between two objects on the other side? Explain.

## Chapter VII

1. Differentiate:  $y = \log_e(x^2+1)$ ,  $y = \log_{10}x^5$ ,  $y = e^{-x^2}$ ,  $y = 100 e^{-5x}$ ,  $y = x^2 \log x$ ,  $y = e^x/(e^x+1)$ .

2. Integrate:  $10 e^{2t} dt$ ,  $(20/x) dx$ ,  $(e^x - e^{-x})^2 dx$ .

3. Find the maximum value of  $y = (\log x)/x^5$ .

4. What rate of interest, compounded annually, gives the same result as 20%, compounded continuously?

5. The speed of a certain chemical reaction increases thus with the temperature:  $dV/dT = .069 V$ . If  $V=20$  when  $T=0$ , write by inspection a formula for  $V$  at any temperature. Derive the same formula by integration.

6. The value of farm lands and buildings in the United States at various times is shown in billions in the adjacent table. Plot the ordinary and semi-logarithmic graphs. In which decade was the percentage rate of increase greatest? Least?

Yr.	VALUE
1850	3.2
1860	6.8
1870	7.3
1880	10.7
1890	13.2
1900	16.8
1910	34.9

7. By the Weber-Fechner law in psychology, the amount of sensation  $E$  produced by any stimulus  $R$  varies thus:  $dE/dR = C/R$ , where  $C$  is a constant. Integrate. Does this come under the  $C. I. L.$ ?



8. The values in the adjacent table satisfy a Power law. State precisely how you could discover that fact for yourself. Also find the exact law.

$x$	$y$
.36	12.40
1.00	7.44
2.25	4.96
5.76	3.10

Chapter VIII

1. Calculate the length, slope, and inclination of the line joining (2, 7) and (5, 12).
2. Is the line joining (0, 0) and (3, -4) perpendicular to that joining (0, 0) and the mid-point between (6, 2) and (2, 4)?
3. Draw the lines:  $2x - y = 7$ ,  $x + y = 5$ ,  $x = 9$ .
4. Simplify the following equations and draw the curves by inspection. Show the foci and asymptotes, if any.

$$9x^2 + 4y^2 + 90x + 16y + 177 = 0, \quad x^2 + 20y = 40,$$

$$x^2 - y^2 - 6x + 4y - 11 = 0, \quad x^2 + y^2 - 6x + 4y - 11 = 0.$$

5. A projectile was fired with an initial speed of 1600 ft./sec. and an inclination angle =  $\tan^{-1}(\frac{3}{4})$ . Find the equation of the path. Locate the vertex by two methods.

6. What sort of curve is the graph of Boyle's law:  $pv = k$ ?

7. (a) How would you draw an ellipse whose longest and shortest diameters are 50 in. and 30 in.? What area would it have? (b) A horizontal beam casts a curved shadow on the wall of a cylindrical gas tank. Precisely what sort of curve is it, and why?

8. A suspension cable, loaded uniformly per horizontal foot, has a horizontal span of 400 ft., and its ends are 60 ft. higher than the middle. Find the equation of its curve, the height 50 ft. from the center, and the position of the focus and directrix. (Cf. § 208.)

9. A point moves in such a way that the lines joining it to (0, 0) and (6, 8) are always perpendicular. Find the equation of the path. Draw the path. Check your result by elementary geometry.

10. The vertices of a triangle are (8, 7), (6, 3), and (0, 9). Show analytically that the three medians are concurrent.

Chapter IX

1. Solve for  $x$ :  $3x^4 - 17x^2 + 5 = 0$ .
2. Is  $12x^2 - 51x + 45$  rationally factorable?
3. Find the lowest rational factors of  $2x^4 - 3x^3 - 7x^2 - 5x - 3$ .
4. Find a root of  $x^3 - 4x - 2 = 0$ , accurate to four decimals.

## Chapter X

- Given  $\text{ctn } \theta = -12/5$ , find without tables all the other functions for both possible values of  $\theta < 360^\circ$ .
- Find the radian equivalent of  $52^\circ 23'$ , and the degree equivalent of  $2.182^{(r)}$ .
- Find from tables the sine, cosine, and tangent of :
 

$105^\circ$ ,	$200^\circ$ ,	$348^\circ 10'$ .
---------------	---------------	-------------------
- Find both possible angles  $< 360^\circ$  for which :
 

$\sin A = -.28765$ ,	$\cos B = -.42859$ ,	$\tan C = 3.6962$ .
----------------------	----------------------	---------------------
- A point  $P$  moved in a circle of radius  $10'$  in. so that  $\theta = .2 t^2$  (radians). Find its speed after 10 sec.
- An alternating current varied thus :  $i = 10 \sin (60 \pi t)$ , the angle  $60 \pi t$  being in radians. Find  $i$  and  $di/dt$  at the instant when  $t = .02$ . When did  $i$  reach its first maximum and when did it next become zero?
- The following table shows the intensity of illumination  $i$  at various inclinations  $\theta^\circ$  from an arc light. Plot in polar coordinates. What is the maximum  $i$ ? For what  $\theta$ ?

$\frac{\theta}{i}$	$\frac{60}{170}$	$\frac{20}{250}$	$\frac{0}{370}$	$\frac{-20}{760}$	$\frac{-30}{1050}$	$\frac{-40}{1230}$	$\frac{-50}{1200}$	$\frac{-70}{700}$
--------------------	------------------	------------------	-----------------	-------------------	--------------------	--------------------	--------------------	-------------------

## Chapter XI

- Differentiate :  $y = (\tan \theta + \text{ctn } \theta) \div \sec \theta \csc^2 \theta$ .
- Integrate :  $10 \sin 6 t dt$ ,  $\cos \theta d \theta$ ,  $\tan \theta d \theta$ .
- Find from the table, pp. 494-497, the following integrals :
 

(a) $\int \frac{d\theta}{\sin^3 \theta}$ ,	(b) $\int \frac{dx}{(x^2+100)^{\frac{3}{2}}}$ ,	(c) $\int \sin 4 \theta \cos 2 \theta d\theta$ .
--	---	--
- Find all values of  $\theta < 360^\circ$  for which  $\sin \theta \cos \theta = .18$ .
- Given  $\sin A = \frac{3}{5}$  and  $\cos B = -\frac{4}{5}$  ( $A$  and  $B$  in the same quadrant); find the functions of  $A+B$  and  $A-B$ .
- If  $\cos \theta = \frac{4}{5}$ , and  $\theta$  is acute, find  $\sin \theta/2$  and  $\sin 2 \theta$ .
- A point moved thus along a straight line :  $x = 8 \cos 10 \pi t$ . What type of motion is this? With what period and amplitude? Find the speed .01 sec. after the point passed through the center.
- What is a cycloid? An involute?
- An alternating current died out thus :  $i = 20 e^{-40t} \sin 400 t$ . Find  $i$ , and the rate at which  $i$  was changing, at  $t = .0015$ . When was the first maximum reached? How frequently did  $i$  become zero?

## Chapter XII

1. Find the value of  $\int_1^5 x^3 dx$  by integration and by using Simpson's rule.
2. By considering concentric shells of "infinitesimal" thickness express the volume of a sphere of radius 10 in. as a definite integral. Work out and check.
3. Find the area generated by revolving the curve  $y = .5x^2$  about the  $X$ -axis from  $x=0$  to  $x=4$ .
4. Draw that part of the surface  $z = x^4 + y^2 + 2$  which stands above the  $XY$ -plane from  $y=0$  to  $y=x$ , and  $x=0$  to 2. Calculate the volume shown in the drawing.
5. Find the slope of the section of the surface in Ex. 4 made by the plane  $x=3$  at the point  $y=2$ . What sort of curve is that section?
6. What is the lowest point on the surface in Ex. 4?

## Chapter XIII

1. Find the 10th term and the sum of the first 8 terms for each of the progressions :
 

(a) 3, 12, 21, ...	(b) 3, 12, 48, ...
(c) 36, 24, 16, ...	(d) 36, 24, 12, ...
2. What is the present value of a bond for \$100 bearing 5% interest, payable semi-annually and maturing 10 years hence, if money is now worth  $4\frac{1}{2}\%$  compounded semi-annually?
3. What net annual premium would provide for an insurance policy of \$2000, if the company earns 5% and the man lives for 37 years? (No installment 37 years hence.)
4. A balance of \$3250 now due on a house is to be paid off in 60 equal monthly payments beginning 1 month hence. How large should each installment be if the interest is at 8%?
5. Because of the accidental death of a workman, the state is to pay his widow 200 monthly installments of \$30 for herself and 100 monthly installments of \$5 for a minor child, beginning 1 mo. hence. What sum set aside to-day and drawing 6% interest, compounded monthly, would suffice to meet these payments?
6. Find the Maclaurin series for  $e^{-x}$  as far as  $x^4$ .

7. Expand  $(2+x)^{10}$  by the Binomial Theorem, as far as  $x^3$ .
8. How is it possible to give a meaning to an imaginary exponent, or logarithm? Find  $\log(-1)$ .
9. How can you ascertain whether the values in a given table satisfy a polynomial formula:  $y = a + bx + cx^2 \dots$ ?

### Chapter XIV

1. How many "words" (spellings) of 4 letters can be made from the 26 letters without repetition in any word?
2. How many committees of 5 could be selected from a class of 20?
3. How many basketball line-ups are possible when organizing a team of 2 seniors and 3 juniors, chosen from 7 seniors and 10 juniors?
4. If 8 cards are drawn from a pack, what is the probability that all will be spades?
5. If we name 5 dates at random, what is the chance that precisely two will be Wednesdays?
6. If we name two dates at random, throw three dice, and draw four cards from a pack, what is the probability that both dates will be Fridays, two dice "fives," and three cards aces? (Express the answer numerically, without calculating it.)
7. If the probable error of a gun is 60 m., and 65% of the shots are "overs," how far is the target from the center of impact and in which direction?
8. Find the most probable formula of  $\frac{x}{y}$  for the adjacent table:
 

$x$	20	30	40
$y$	17.9	26.9	36.2
9. The following tables relate to the statures of a certain group of fathers and sons. Find the most probable linear formulas for  $\bar{y}$  and  $\bar{x}$ ; also the index of correlation. (See Ex. 6, p. 459.)\*

$x$	64	66	68	70		$y$	65	67	69	71
$\bar{y}$	66.7	67.6	69.0	69.7		$\bar{x}$	65.4	66.5	67.9	69

### Chapter XV

1. Calculate:  $(3+2i) \cdot (4-7i)$ , and  $8i \div (3-5i)$ .
2. Express the following numbers in polar form and find the fifth roots of each:  $i$ ,  $-32$ ,  $3+4i$ .
3. Calculate  $(\cos 40^\circ + i \sin 220^\circ)^6$ .

\* Also cf. G. U. Yule, *Intro. to Theory of Statistics*.

# GENERAL REVIEW

## Miscellaneous Exercises

INCLUDING SOME PROBLEMS INVOLVING COMBINATIONS OF  
PRINCIPLES

1. The speed  $V$  of a chemical reaction is 36 units at a temperature of  $20^\circ$ , and doubles with every rise of  $10^\circ$ . Obtain a formula for the speed at any temperature  $T^\circ$ . Find  $V$  when  $T=25$ .

2. A point moves so that its distance from  $(3, 0)$  is always twice its distance from  $(0, 0)$ . Find the equation of the path and draw it.

3. Express by formulas the answers to these questions:

(a) How much deposited now would provide for 18 annual installments of \$900 each, beginning 24 years hence, if interest is at 6%?

(b) How much must we pay quarterly, 20 times, beginning 3 months hence, to pay off \$3000 now due on a house, with interest at 8% compounded quarterly?

4. Simplify  $\csc \theta \div (\tan \theta + \cot \theta)$  and find its value when  $\theta = 290^\circ$ .

5. Find all possible values of  $\theta < 360^\circ$  for which

$$\cos \theta (2 \sin \theta + 1)(\sin \theta - \cos \theta) = 0.$$

6. The same as Ex. 5 for  $27 \sec^2 \theta - 54 \tan \theta - 35 \cot \theta + 9 = 0$ .

7. Given a table of bank clearings each year for 50 years past, what is the best way to plot, to exhibit percentage gains or losses in various intervals? Why?

8. Given any table of experimental values, how would you proceed to discover the *law*?

9. Find all the rational roots of  $3x^5 + 5x^4 - 17x^3 - 22x^2 + 15x - 2$  and approximate one irrational root to 2 decimals.

10. A string is unwound from a circle of radius 10 in. at an angular rate of .1 (rad./sec.). Find how fast its end  $P$  is moving when  $t=2$ . Also find how far  $P$  travels in the first 10 sec.

11. A hemispherical cistern of radius 10 ft. is full of water. Calculate the volume of water by elementary geometry, by the prismoid formula, and by integration.

12. (a) Calculate the wet area of the cistern in Ex. 11 by integration, and check. (b) Knowing that the pressure  $x$  ft. below the surface is  $62.5x$  lb. per sq. ft., find the total force with which the water presses against the cistern.

13. In Ex. 11 find the work required to pump all the water up to a level 4 ft. above the top.

14. Differentiate and simplify :

$$(a) \log(x+1) + \frac{4x+3}{2(x+1)^2}, \quad (b) \frac{\tan \theta + \operatorname{ctn} \theta}{\csc \theta},$$

$$(c) \frac{\cos x}{\sin x \operatorname{ctn}^2 x}, \quad (d) \frac{1 - \cos x}{x^2},$$

$$(e) \log \sqrt{\frac{1-x}{1+x}}, \quad (f) e^{-20t} \sin 400t.$$

15. Integrate, using tables if necessary :

$$(a) \csc^3 t \operatorname{ctn} t dt, \quad (b) \sqrt{x^2 - 100} x dx,$$

$$(c) \frac{dx}{(100 - x^2)^{\frac{3}{2}}}, \quad (d) \frac{dx}{x^2 \sqrt{x^2 - 25}},$$

$$(e) 25 e^{-2t} \cos 3t dt, \quad (f) 30 \sin 200t dt.$$

16. Find the numerical values of

$$\int_0^5 (e^x + e^{-x})^2 dx, \quad \int_{\pi/4}^{\pi/2} \operatorname{ctn} \theta d\theta.$$

17. A point moves so that its distance from the point  $(0, -16)$  is always  $\frac{2}{3}$  of its distance from the  $X$ -axis. Find the equation of its path. Also draw the path roughly, but so as to show clearly its character.

18. A man bought a piece of property for \$1000, and ten years later bought another for \$2000. After five years more, he sold the two for \$5000. The income had meantime just paid for taxes and repairs. To what rate of interest, compounded annually, would this profit be equivalent? (Give the answer correct to the nearest tenth of 1%.)

19. What is the curve  $10x^2 - 2xy + y^2 = 36$ ; and what if any horizontal or vertical boundaries has it?

20. Derive Maclaurin's series for  $e^x$ , to several terms. Calculate  $e$  to four decimals; also  $\int_0^1 (e^x - 1) dx/x$ .

21. Would \$50, deposited now in a bank which pays 4% interest, yield enough for 30 annual payments of \$3 beginning 1 year hence? What balance or deficit at the time of the last payment?

22. Prove analytically: The perpendicular bisector of the line joining the points  $A(1, -9)$  and  $B(5, 3)$  is the locus of points equidistant from  $A$  and  $B$ .

23. At what inclination should a projectile be fired from  $(0, 0)$ , with an initial speed of 2000 ft./sec., to strike the point  $(40,000, 20,000)$ , ignoring air resistance?

24. If a ball nine containing 3 seniors, 2 juniors, 4 sophomores draw batting positions at random, what is the chance that the seniors will bat before all others and the juniors after all others?

25. If the chance for a certain event to occur twice in three trials is .15, what is the chance,  $p$ , that it will occur in a single trial? (Find  $p$  correct to 2 decimals.)

26. An electric current died out as in the adjacent table. Find a formula for the intensity at any time. Find the rate of decrease at  $t=.004$  and the quantity of electricity passed from  $t=0$  to  $t=.01$ .

$t$	$i$
0	100
.002	36.79
.004	13.53
.006	4.98
.008	1.83
.010	.67

27. (a) Prove that the volume of a segment cut from a sphere of radius 10 ft. by a plane  $h$  ft. from the center is  $V = \frac{\pi}{3} (2000 - 300h + h^3)$ .

(b) Using this formula, find how deep the water would have to be in a hemispherical cistern of radius 10 ft. if the cistern were half full.

28. If 9 coins are tossed up, what is the chance for no head, 1 head, 2 heads, etc., up to 5 heads? Plot the "staircase" distribution.

29. How many triangles could be drawn having vertices at points  $A, B, C, D, E, F, G, H, I, J,$  and  $K$ , no three of which are in one straight line?

30. On a certain day two planets had the positions  $U (19.8, 303^\circ 14')$  and  $N (30, 114^\circ 34')$ . Find their distance apart and their rectangular coördinates, at that time.

31. A point  $(x, y)$  moved thus:  $x = 10 \cos t, y = 10 \sec t$ . Find the speed and direction of motion at  $t = \pi/4$ . Also find precisely what kind of curve the path was, and the area under that curve from  $x = .5$  to  $x = 1$ .

32. Write by inspection the product of the two complex numbers  $7 (\cos 80^\circ + i \sin 80^\circ)$  and  $2 (\cos 5^\circ + i \sin 5^\circ)$ . Verify your result by multiplying out and comparing.

33. The "hyperbolic sine" and "hyperbolic cosine" of  $x$  are two higher functions defined as follows:

$$\sinh x = \frac{1}{2} (e^x - e^{-x}), \quad \cosh x = \frac{1}{2} (e^x + e^{-x}).$$

Find the value of each when  $x=0$  and when  $x=1$ . What is the derivative of each? Find Maclaurin's series for  $\cosh x$  as far as  $x^3$ .

34. A flywheel of radius 5 ft. was turning with an angular speed of 16 rad./min. when the power was cut off, after which the acceleration was  $d^2 \theta / dt^2 = 12 t^2 - 24 t$ . Find how far a point on the rim traveled while the wheel was coming to rest.





## APPENDIX

- I. PROOFS OF CERTAIN THEOREMS.
- II. NUMERICAL SHORT-CUTS.
- III. FORMULAS.
- IV. THE IDEA OF INFINITY.
- V. TABLE OF INTEGRALS.
- VI. NUMERICAL TABLES.

## PROOFS OF CERTAIN THEOREMS

### (A) SOME THEOREMS ON LIMITS

(I) *If  $\Delta x \rightarrow 0$  and  $k$  is any fixed number, then  $k \Delta x \rightarrow 0$ .*

For  $k \Delta x$  will become and remain numerically less than any number  $e$  that you may name, as soon as  $\Delta x$  becomes and remains less than  $e/k$ .

(II) *If  $\Delta x \rightarrow 0$  and  $n$  is any positive integer, then  $\Delta x^n \rightarrow 0$ .*

For as soon as the numerical value of  $\Delta x$  is less than 1, any power of  $\Delta x$  will be smaller than  $\Delta x$  itself. Hence  $\Delta x$  will become and remain numerically less than any small positive number  $e$ , as soon as  $\Delta x$  becomes and remains less than  $e$ .

(III) *If  $\Delta x \rightarrow 0$  and  $a, b, c, \dots, k$ , are any positive numbers, then the quantity  $(\pm a \Delta x \pm b \Delta x^2 \pm c \Delta x^3 \dots \pm k \Delta x^n) \rightarrow 0$ .*

For each power of  $\Delta x$  approaches zero by Theorem II and hence can be made as small as we please. Let the sum of the numerical values of  $a, b, c, \dots, k$ , be denoted by  $m$ , some fixed number. Then as soon as  $\Delta x$  is small enough to make each power less than  $e/m$ , the given quantity will be less than  $(\pm a \frac{e}{m} \pm b \frac{e}{m} \pm c \frac{e}{m} \dots \pm k \frac{e}{m})$ , and hence less than  $(a+b+c \dots +k)e/m$ , or  $m e/m$ , or  $e$ .

### (B) INSTANTANEOUS SPEED AND DIRECTION OF MOTION

$$v = \sqrt{v_x^2 + v_y^2}, \quad (1)$$

$$\tan A = v_y/v_x. \quad (2)$$

*Proof of (1):* Let  $\Delta s$  be the length of arc  $PQ$  traveled during a short time  $\Delta t$ , just following the instant. Then the required speed  $v$  is the limit of the average speed  $\Delta s/\Delta t$ .

There is no simple relation between  $\Delta s$ ,  $\Delta x$ , and  $\Delta y$ . But

$$\begin{aligned} \text{chord } PQ^2 &= \Delta x^2 + \Delta y^2, \\ \left(\frac{\Delta s}{\Delta t}\right)^2 \left(\frac{\text{chord } PQ}{\Delta s}\right)^2 &= \left(\frac{\Delta x}{\Delta t}\right)^2 + \left(\frac{\Delta y}{\Delta t}\right)^2. \end{aligned} \quad (3)$$

Let  $\Delta t \rightarrow 0$ . Then  $(\Delta s/\Delta t) \rightarrow v$ ,  $(\Delta x/\Delta t) \rightarrow v_x$ ,  $(\Delta y/\Delta t) \rightarrow v_y$ . Also the ratio of chord  $PQ$  to arc  $\Delta s$  approaches 1 as the arc becomes more nearly straight. Taking limits in (3) we have (1).

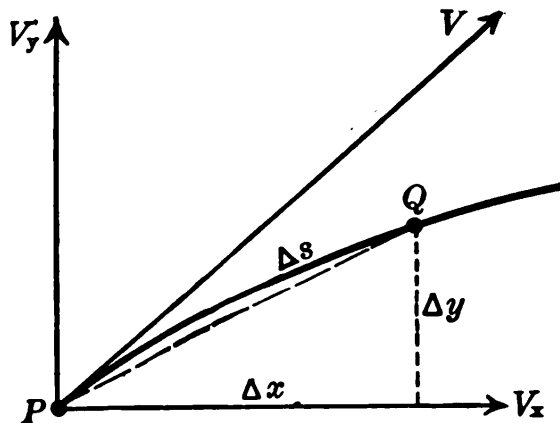

FIG. 152.

*Proof of (2):* The direction of motion is the direction of the tangent line.

$$\tan A = \frac{dy}{dx}.$$

Dividing numerator and denominator by  $dt$ , we have (2).

### (C) DIVISION BY SYNTHETIC SUBSTITUTION

*Theorem:* The quotient and remainder which result from dividing any given polynomial

$$a_1x^n + a_2x^{n-1} + a_3x^{n-2} \dots + a_nx + a_{n+1}$$

by  $(x - k)$  can be found by substituting  $k$  for  $x$  synthetically :

$$\begin{array}{r} a_1 \quad +a_2 \quad +a_3 \quad \dots \quad +a_n \quad +a_{n+1} \quad \boxed{k} \\ \hline \phantom{a_1} \quad ka_1 \quad kS_1 \quad \dots \quad kS_{n-2} \quad kS_{n-1} \\ \hline a_1 \quad S_1 \quad S_2 \quad \dots \quad S_{n-1} \quad S_n \end{array}$$

[Here  $S_1$  denotes the first sum ;  $S_2$ , the second sum ; etc., *i.e.*,

$$S_1 = ka_1 + a_2, \quad S_2 = kS_1 + a_3, \text{ etc.}] \quad (4)$$

In other words : the remainder is  $S_n$  and the quotient is

$$Q = a_1x^{n-1} + S_1x^{n-2} + S_2x^{n-3} \dots + S_{n-1}.$$

*Proof:* To verify this (or any other) division we need merely show that multiplying the supposed quotient by the divisor  $(x-k)$  and adding the supposed remainder  $[S_n]$  will give the original quantity.

$$\begin{array}{r}
 a_1x^{n-1} \qquad \qquad +S_1x^{n-2} \qquad \qquad +S_2x^{n-3} \dots \qquad +S_{n-1} \\
 \hline
 a_1x^n \quad +S_1x^{n-1} \quad +S_2x^{n-2} \dots \quad +S_{n-1}x \quad [ +S_n ] \\
 \quad -ka_1x^{n-1} \quad -kS_1x^{n-2} \dots \quad -kS_{n-2}x \quad -kS_{n-1} \\
 \hline
 a_1x^n \quad + (S_1 - ka_1)x^{n-1} \quad + (S_2 - kS_1)x^{n-2} \dots \quad + (S_{n-1} - kS_{n-2})x \quad + (S_n - kS_{n-1})
 \end{array}$$

But, by (4) above,  $S_1 - k_1a_1 = a_2$ ,  $S_2 - kS_1 = a_3$ , etc.

Hence the multiplication and addition give the original quantity  $a_1x^n + a_2x^{n-1} + a_3x^{n-2} \dots + a_nx + a_{n+1}$ , which verifies the division.

(D) ADDITION FORMULAS FOR THE SINE AND COSINE :  
 ANGLES OF ANY SIZE

$$\begin{aligned}
 \sin (A+B) &= \sin A \cos B + \cos A \sin B, \\
 \cos (A+B) &= \cos A \cos B - \sin A \sin B.
 \end{aligned} \tag{5}$$

These formulas are established in § 281 for the case where  $A$ ,  $B$  and  $A+B$  are all acute angles. The generalization of this proof will be effected in three steps:

(I) *The formulas are valid when  $A$  and  $B$  are acute angles out  $(A+B)$  is obtuse.*

The proof is again geometrical, the construction and steps being identically the same as in § 281, — with the single exception that since  $\cos (A+B)$  is now negative, we must equate it to a difference of lines so chosen as to be negative.

That is, formulas (5) are valid for all acute angles  $A$ ,  $B$ , whether  $A+B$  is acute or obtuse.

(II) *The formulas are valid if either  $A$  or  $B$  is increased by  $90^\circ$ , — that is, if one angle is obtuse and the other acute.*

For suppose  $A = 90^\circ + A'$ , where  $A'$  and also  $B$  are acute. Then

$$\sin (A+B) = \sin (90^\circ + A' + B) = \cos (A' + B).*$$

\* If two angles differ by  $90^\circ$ , the sine of the larger equals the cosine of the smaller; and the cosine of the larger equals minus the sine of the smaller. (See § 259.)

But as  $A'$  and  $B$  are acute, we already know that

$$\cos (A'+B) = \cos A' \cos B - \sin A' \sin B.$$

And  $A'$  being  $90^\circ$  smaller than  $A$ , we may substitute

$$\begin{aligned} \cos A' &= \sin A, & -\sin A' &= \cos A.* \\ \therefore \sin (A+B) &= \cos (A'+B) = \sin A \cos B + \cos A \sin B, \end{aligned}$$

which is the first of formulas (5) valid for  $A$  obtuse and  $B$  acute. The same argument can be applied to  $\cos (A+B)$ .

Evidently the above argument can be repeated if either angle is again increased by  $90^\circ$ ; and so on indefinitely. Hence (5) are true for all positive angles, no matter how large.

(III) *Finally, (5) are true when  $A$  and  $B$  are either or both negative.*

For the functions of a negative angle are the same as those of a positive angle, larger by a multiple of  $360^\circ$ . And the formulas are known to be valid for all positive angles.

*Remark.* When  $B$  is negative,  $= -B'$  say, (4) becomes

$$\sin [A + (-B')] = \sin A \cos (-B') + \cos A \sin (-B').$$

But, as can be seen from a figure by using the definitions in § 254 :

$$\begin{aligned} \cos (-B') &= \cos B', & \sin (-B') &= -\sin B'. & (6) \\ \therefore \sin (A - B') &= \sin A \cos B' - \cos A \sin B'. \end{aligned}$$

Likewise

$$\cos (A - B') = \cos A \cos B + \sin A \sin B. \quad (7)$$

These may be considered as *Subtraction Formulas*.

### (E) AREA OF A TRIANGLE. (Cf. § 151)

$$S = \sqrt{h(h-a)(h-b)(h-c)}.$$

*Proof:* Let  $p$  be the altitude of the triangle drawn to the base  $b$ , — cutting  $b$  into segments  $x$  and  $b-x$ . (Draw a figure.)

$$\begin{aligned} \text{Then} & & p^2 &= a^2 - x^2 = c^2 - (b-x)^2, \\ \text{whence} & & x &= (a^2 + b^2 - c^2) \div 2b. \end{aligned}$$

Substituting this value of  $x$  in  $p^2 = (a+x)(a-x)$ , gives :

$$\begin{aligned} p^2 &= \left[ a + \frac{a^2 + b^2 - c^2}{2b} \right] \cdot \left[ a - \frac{a^2 + b^2 - c^2}{2b} \right] \\ &= [(a+b)^2 - c^2][c^2 - (a-b)^2] \div 4b^2 \\ &= \frac{(a+b+c)(a+b-c)(c+a-b)(c-a+b)}{4b^2}. \end{aligned}$$

Now the quantities in these parentheses are seen to be

$$\begin{aligned} &2h, \quad 2h-2c, \quad 2h-2b, \quad 2h-2a \\ \therefore p^2 &= \frac{16h(h-c)(h-b)(h-a)}{4b^2}. \end{aligned}$$

And since the area of the triangle is  $\frac{1}{2}bp$ , we have

$$S = \frac{1}{2}b\sqrt{\frac{4h(h-a)(h-b)(h-c)}{b^2}},$$

which simplifies at once to the formula above.

### (F) SIMPSON'S RULE

*Theorem:* Simpson's rule gives the exact value of the integral from  $a$  to  $b$  of any cubic function:  $y = k + lx + mx^2 + nx^3$ .\*

Proof :                      At  $x = a$ ,  $y_1 = k + la + ma^2 + na^3$ ,  
                                     at  $x = b$ ,  $y_2 = k + lb + mb^2 + nb^3$ ,

and mid-way between, at  $x = (a+b)/2$ ,

$$y_m = k + l\frac{a+b}{2} + m\left(\frac{a+b}{2}\right)^2 + n\left(\frac{a+b}{2}\right)^3.$$

Multiplied out and used in the rule, this gives

$$\frac{1}{3}(y_1 + y_2 + 4y_m)(b-a) = k(b-a) + \frac{l}{2}(b^2 - a^2) + \frac{m}{3}(b^3 - a^3) + \frac{n}{4}(b^4 - a^4).$$

But this is precisely the value of the integral :

$$\int_a^b y \, dx.$$

Q. E. D.

\* For  $n = 0$  this covers also quadratics. And so on.

## NUMERICAL SHORT-CUTS

## (A) In Squaring Numbers Mentally

(I) To square any number ending in  $\frac{1}{2}$ , say  $(n + \frac{1}{2})$ , simply multiply the integer  $n$  by the next higher integer, and add  $\frac{1}{4}$ .

Thus  $(6\frac{1}{2})^2 = (6 \times 7) + \frac{1}{4} = 42\frac{1}{4}$ ;  $(10\frac{1}{2})^2 = 110\frac{1}{4}$ .

Similarly,  $65^2 = 4225$ ;  $105^2 = 11025$ ; etc.

(II) To square a number near 100, add to the number its excess over 100, consider the result as "hundreds," and add the square of the excess.

*E.g.*,  $107^2 = (107 + 7) \text{ hundreds} + 7^2 = 11449$ .

If  $N$  is less than 100, its excess is negative. Thus for 93,  $e = -7$ :

$$\therefore 93^2 = [93 + (-7)] \text{ hundreds} + (-7)^2 = 8649.$$

(III) To square a number near 50, find its excess over 50, add this to 25 to get the "hundreds"; then add the square of the excess.

*E.g.*,  $54^2 = (25 + 4) \text{ hundreds} + 4^2 = 2916$ .

## (B) In Multiplying and Dividing

(I) *Multiplying by 25*: multiply by 100 and divide by 4.

*Dividing*: reverse this. *E.g.*,  $124375 \div 125 = 124.375 \times 8 = 995$ .

(II) *Multipliers slightly less than an even thousand or hundred*. *E.g.*, to multiply by 297, multiply by 300 and subtract 3 times the number.

(III) To multiply together two nearly equal numbers which differ by an even integer, use the idea that  $(a+b)(a-b) = a^2 - b^2$ .

*E.g.*,  $43 \times 37 = (40 + 3)(40 - 3) = 1600 - 9$ .

## (C) Some Simple Approximations

(When  $x$  is a small fraction.)

<i>Formulas</i>	<i>Illustrations</i>
$(1 \pm x)^n = 1 \pm nx$	$(1.002)^4 = 1.008$ ; $(.999)^3 = 1 - .003$
$\sqrt[n]{1 \pm x} = 1 \pm x/n$	$\sqrt[4]{1.006} = 1.0012$ ; $\sqrt[3]{.9996} = .9998$ .
$\frac{a}{1 \pm x} = a \mp ax$	$\frac{7}{.9996} = 7 + 7(.0004), = 7.0028$ .
$\log_e(1 \pm x) = \pm x - \frac{1}{2} x^2$	$\log_e(1.0025) = .0025$
$\sin x^{(r)} = \tan x^{(r)} = x$ .	$\sin .004^{(r)} = .004$
$\cos x^{(r)} = 1 - \frac{1}{2} x^2$ .	$\cos .006^{(r)} = 1 - .000018$ .

## SOME STANDARD FORMULAS

## (A) MENSURATION. (Cf. § 61)

Circle :	$C = 2 \pi r,$	$A = \pi r^2.$
Sphere :	$S = 4 \pi r^2,$	$V = \frac{4}{3} \pi r^3.$
Cylinder :	$S = 2 \pi r h,$	$V = \pi r^2 h.$
Cone :	$S = \pi r s,$	$V = \frac{1}{3} \pi r^2 h.$
Frustum :	$S = \pi (R+r) s,$	$V = \frac{1}{3} \pi h (R+Rr+r^2).$
Segment, of height $h$ , cut from sphere of radius $r$ :	$S = 2 \pi r h,$	$V = \frac{1}{3} \pi h^2 (3r-h).$

## (B) ALGEBRA

Roots of Quadratic,  $ax^2+bx+c=0$  :  $x = \frac{-b \pm \sqrt{b^2-4ac}}{2a}.$

Interest :  $A = P(1+r/k)^{kn}, P = A/(1+r/k)^{kn}.$

Geom. Progression :  $l = ar^{n-1}, S = a(r^n-1) \div (r-1).$

Arith. " :  $l = a+(n-1)d, S = \frac{1}{2}(a+l).$

Relation of base  $e$  to base 10 :  $\log_e N = 2.30259 \log_{10} N.$

## (C) TRIGONOMETRY

Definitions :

$\sin \theta = y/r,$  (=ordinate  $\div$  rad. vector), etc. [§ 253.]

Basic Identities :

$\sin^2 \theta + \cos^2 \theta = 1, \tan \theta = \sin \theta / \cos \theta,$  etc. [§ 270.]

Addition Formulas :

$\sin (A+B) = \sin A \cos B + \cos A \sin B,$  etc. [§ 280.]

Double-angles :

$\sin 2 \theta = 2 \sin \theta \cos \theta, \cos 2 \theta = \cos^2 \theta - \sin^2 \theta.$

Half-angles :

$\sin (\frac{1}{2} \theta) = \sqrt{\frac{1}{2}(1-\cos \theta)}, \cos (\frac{1}{2} \theta) = \sqrt{\frac{1}{2}(1+\cos \theta)}.$

Triangle-laws: Sines, Cosines, Tangents, Half-angles,  
Area : see text references in Index.

Projections :  $p = s \cos A, P = S \cos A.$  [§ 113.]



(D) ANALYTIC GEOMETRY

Distance:  $d = \sqrt{(x_2 - x_1)^2 + (y_2 - y_1)^2}$ .

Mid-point:  $\bar{x} = \frac{1}{2}(x_1 + x_2)$ ,  $\bar{y} = \frac{1}{2}(y_1 + y_2)$ .

Slope:  $l = (y_2 - y_1) \div (x_2 - x_1)$ .

Inclination:  $\tan \theta = l$ .

Perpendiculars:  $l_1 l_2 = -1$ , or  $l_2 = -1/l_1$ .

For equations of lines and curves, see Index under name of that curve.

(E) DERIVATIVES

$y =$	$dy/dx =$	$y =$	$dy/dx =$
$u^n$	$nu^{n-1} du/dx$	$\dagger \sin u$	$\cos u du/dx$
$x^n$	$nx^{n-1}$	$\cos u$	$-\sin u du/dx$
$* \log u$	$\frac{1}{u} du/dx$	$\tan u$	$\sec^2 u du/dx$
$\log x$	$\frac{1}{x}$	$\text{ctn } u$	$-\text{csc}^2 u du/dx$
$e^u$	$e^u du/dx$	$\sec u$	$\sec u \tan u du/dx$
$e^x$	$e^x$	$\text{csc } u$	$-\text{csc } u \text{ ctn } u du/dx$
$a^u$	$a^u \log_e a du/dx$	$uv$	$u dv/dx + v du/dx$
		$\frac{u}{v}$	$\frac{v du/dx - u dv/dx}{v^2}$

THE IDEA OF "INFINITY"

ILLUSTRATION. If  $y = 60/(2-x)$ , then

- (a) There is no possible value for  $y$  when  $x = 2$ ;
- (b) As  $x$  approaches 2,  $y$  exists and increases without limit.

These facts are often stated briefly by saying that

“ $y$  approaches infinity ( $y \rightarrow \infty$ ) as  $x \rightarrow 2$ ,”  
 or “ $y = \text{infinity}$  ( $y = \infty$ ), when  $x = 2$ .”

These statements, however, must not be misunderstood as saying that there is some enormous number ( $\infty$ ) which  $y$  equals when  $x = 2$ . They are to be used only in a technical sense, as a brief way of stating the two facts (a) and (b) above.

\* Base  $e$ .

† Radian measure.

# TABLE OF INTEGRALS

## GENERAL HINTS

- I. *Sums* of several terms: integrate term by term.
- II. *Products* or *powers*: multiply out if necessary and feasible.
- III. *Fractions*: often simplified by dividing out, or by writing as negative powers.
- IV. *Radicals*: may be regarded as fractional powers.
- V. *High powers*: use reduction formulas (32)–(44).
- VI. *Quadratic expressions* like  $ax^2 + bx + c$  can be reduced to binomial forms like  $a(t^2 + k)$  by *completing the square*:  

$$ax^2 + bx + c = a \left[ \left( x + \frac{b}{a} + \frac{b^2}{4a^2} \right) + \left( \frac{c}{a} - \frac{b^2}{4a^2} \right) \right]; \text{ let } \left( x + \frac{b}{2a} \right) = t.$$
- VII. A *constant* should be added to each integral below.

## INTEGRALS

$$1. \int u^n du = \frac{1}{n+1} u^{n+1} \quad (n \neq -1).$$

Here  $n$  may have any positive or negative value except  $-1$ . *E.g.*,  
 $\int x^{\frac{1}{2}} dx = \frac{2}{3} x^{\frac{3}{2}}$ ;  $\int x^{-1.73} dx = -\frac{1}{.73} x^{-.73}$ .

(2)–(4) are special cases of (1).

$$2. \int (ax^m + b)^n x^{m-1} dx = \frac{1}{n+1} \cdot \frac{1}{ma} \cdot (ax^m + b)^{n+1}.$$

This includes forms like  $\sqrt{x^2+25} x^3 dx$ ,  $\sqrt{4-x^2} x dx$ ,  $(3x^2+7)^{10} x dx$ ,  $x dx/(x^2-16)^{\frac{1}{2}}$ , etc. Simply use in (2) the values of  $a$ ,  $b$ ,  $m$ ,  $n$ , which appear in each of these forms.

$$3. \int \sin^n x \cos x dx = \frac{1}{n+1} \sin^{n+1} x.$$

$$4. \int \cos^n x \sin x dx = -\frac{1}{n+1} \cos^{n+1} x.$$

These include forms like  $\sin^5 x \cos x dx$ ,  $\sin x dx/\cos x$ , etc.

$$5. \int \frac{du}{u} = \log u.$$

(6)–(10) are special cases of (5).

$$6. \int \frac{x^{m-1} dx}{ax^m + b} = \frac{1}{ma} \log (ax^m + b).$$

This includes forms like  $x^4 dx / (2x^4 - 5)$ ,  $\sqrt{x} dx / (7x^{\frac{3}{2}} + 9)$ , etc.

$$7. \int \operatorname{ctn} ax dx = \int \frac{\cos ax}{\sin ax} dx = \frac{1}{a} \log \sin ax.$$

$$8. \int \tan ax dx = -\frac{1}{a} \log \cos ax, = \frac{1}{a} \log \sec ax.$$

$$9. \int \sec ax dx = \int \frac{(\sec^2 ax + \sec ax \tan ax) dx}{\sec ax + \tan ax} = \frac{1}{a} \log (\sec ax + \tan ax).$$

$$10. \int \csc ax dx = -\frac{1}{a} \log (\csc ax + \operatorname{ctn} ax).$$

$$11. \int \sin ax dx = -\frac{1}{a} \cos ax; \quad \int \cos ax dx = \frac{1}{a} \sin ax.$$

$$12. \int \frac{dx}{a \sin x + b \cos x} = \frac{1}{\sqrt{a^2 + b^2}} \log \tan \frac{x+k}{2}, \text{ where } k = \tan^{-1} b/a.$$

$$13. \int e^u du = e^u; \quad \int e^{kx} dx = \frac{1}{k} e^{kx}.$$

$$14. \int e^{kx} \sin ax dx = \frac{e^{kx}}{k^2 + a^2} (k \sin ax - a \cos ax).$$

$$15. \int e^{kx} \cos ax dx = \frac{e^{kx}}{k^2 + a^2} (k \cos ax + a \sin ax).$$

$$16. \int \cos ax \cos bx dx = \frac{\sin (a-b)x}{2(a-b)} + \frac{\sin (a+b)x}{2(a+b)}.$$

$$17. \int \sin ax \sin bx dx = \frac{\sin (a-b)x}{2(a-b)} - \frac{\sin (a+b)x}{2(a+b)}.$$

$$18. \int \sin ax \cos bx dx = -\frac{\cos (a-b)x}{2(a-b)} - \frac{\cos (a+b)x}{2(a+b)}.$$

}  $a \neq b$ .

$$19. \int \cos^2 ax dx = \frac{1}{2a} [ax + \frac{1}{2} \sin 2ax].$$

$$20. \int \sin^2 ax dx = \frac{1}{2a} [ax - \frac{1}{2} \sin 2ax].$$

21.  $\int \frac{du}{u^2 - a^2} = \frac{1}{2a} \log \frac{u-a}{u+a}.$
22.  $\int \frac{du}{u^2 + a^2} = \frac{1}{a} \tan^{-1} \frac{u}{a}, = \frac{-1}{a} \operatorname{ctn}^{-1} \frac{u}{a}.$
23.  $\int \frac{du}{\sqrt{u^2 \pm a^2}} = \log (u + \sqrt{u^2 \pm a^2}).$
24.  $\int \frac{du}{\sqrt{a^2 - u^2}} = \sin^{-1} \frac{u}{a}, = -\cos^{-1} \frac{u}{a}.$
25.  $\int \sqrt{a^2 - u^2} du = \frac{u}{2} \sqrt{a^2 - u^2} + \frac{a^2}{2} \sin^{-1} \frac{u}{a}.$
26.  $\int \frac{du}{u\sqrt{u^2 - a^2}} = \frac{1}{a} \sec^{-1} \frac{u}{a}, = \frac{1}{a} \cos^{-1} \frac{a}{u}.$
27.  $\int \frac{du}{(u^2 \pm a^2)^{\frac{3}{2}}} = \frac{\pm u}{a^2 \sqrt{u^2 \pm a^2}}; \quad \int \frac{du}{(a^2 - u^2)^{\frac{3}{2}}} = \frac{u}{a^2 \sqrt{a^2 - u^2}}.$
28.  $\int \frac{du}{u\sqrt{au+b}} = \int \frac{2 dr}{r^2 - b},$  where  $r = \sqrt{au+b}.$  Use (21) or (22).
29.  $\int \sin^{-1} x dx = x \sin^{-1} x + \sqrt{1-x^2}.$
30.  $\int \tan^{-1} x dx = x \tan^{-1} x - \frac{1}{2} \log (1+x^2).$
31.  $\int x^n \log x dx = x^{n+1} [(n+1) \log x - 1] \div (n+1)^2.$

## REDUCTION FORMULAS

32.  $\int x^n e^{kx} dx = \frac{1}{k} x^n e^{kx} - \frac{n}{k} \int x^{n-1} e^{kx} dx.$  Leads to (13).
33.  $\int x^n \cos ax dx = \frac{x^n}{a} \sin ax - \frac{n}{a} \int x^{n-1} \sin ax dx.$
34.  $\int x^n \sin ax dx = -\frac{x^n}{a} \cos ax + \frac{n}{a} \int x^{n-1} \cos ax dx.$  } Lead to (11).
35.  $\int \sin^n ax dx = -\frac{\sin^{n-1} ax \cos ax}{na} + \frac{n-1}{n} \int \sin^{n-2} ax dx.$  (11),  
(19),
36.  $\int \cos^n ax dx = \frac{\cos^{n-1} ax \sin ax}{na} + \frac{n-1}{n} \int \cos^{n-2} ax dx.$  or  
(20).

$$37. \int \tan^n ax \, dx = \frac{\tan^{n-1} ax}{(n-1)a} - \int \tan^{n-2} ax \, dx.$$

$$38. \int \operatorname{ctn}^n ax \, dx = -\frac{\operatorname{ctn}^{n-1} ax}{(n-1)a} - \int \operatorname{ctn}^{n-2} ax \, dx.$$

$$39. \int \sec^n ax \, dx = \frac{1}{(n-1)a} \sin ax \sec^{n-1} ax + \frac{n-2}{n-1} \int \sec^{n-2} ax \, dx.$$

$$40. \int \csc^n ax \, dx = \frac{-1}{(n-1)a} \cos ax \csc^{n-1} ax + \frac{n-2}{n-1} \int \csc^{n-2} ax \, dx.$$

In (41)–(44) below,  $u$  denotes  $ax^n + b$ , and each formula is valid as long as its denominator is not zero. When a denominator is zero, the expression is integrable by some other formula, such as (2), (6), (21), etc., or by substituting  $ax^n + b = t$  or  $x^n t$ .

$$41. \int x^m (ax^n + b)^p dx = \frac{1}{m+np+1} \left( x^{m+1} u^p + npb \int x^m u^{p-1} dx \right).$$

$$42. \int x^m (ax^n + b)^p dx = \frac{1}{bn(p+1)} \left( -x^{m+1} u^{p+1} + (m+n+np+1) \int x^m u^{p+1} dx \right).$$

$$43. \int x^m (ax^n + b)^p dx = \frac{1}{(m+1)b} \left( x^{m+1} u^{p+1} - a(m+n+np+1) \int x^{m+n} u^p dx \right).$$

$$44. \int x^m (ax^n + b)^p dx = \frac{1}{a(m+np+1)} \left( x^{m-n+1} u^{p+1} - (m-n+1)b \int x^{m-n} u^p dx \right).$$

*N.B.* By (41)–(44) the power of the binomial can be raised or lowered by one unit at each step, or the power outside be increased or decreased by the power inside the parentheses.

These formulas cover such types as:

$$\int x^3 (2x^3 + 5)^{\frac{3}{2}} dx, \text{ [Use (44) twice]; } \int \frac{dx}{(x^2 + 16)^3}, \text{ [} m=0, \text{ (42) twice];}$$

$$\int \sqrt{16+x^2} \, dx, \text{ [(41) once, then (23)]; } \int \frac{xdx}{\sqrt{ax+b}}, \text{ [(44) once].}$$

## APPLICATIONS

45. Area under a curve $y=f(x)$ ,	$A = \int y dx.$
46. Volume of a solid, sectional area $A_s$ ,	$V = \int A_s dx.$
47. Length of curve, $y=f(x)$ ,	$s = \int \sqrt{1+(dy/dx)^2} dx.$
48. Surface of revolution about $X$ -axis,	$S = \int 2 \pi y ds.$
49. Length of curve, $r=f(\theta)$ ,	$s = \int \sqrt{r^2+(dr/d\theta)^2} d\theta.$
50. Work of a force,	$W = \int F dx.$
51. Momentum generated,	$M = \int F dt.$
52. Total water pressure,	$F = \int 62.5 xw dx.$
53. Total attraction of rod,	$F = \int mk dx/x^2.$
54. Quantity of electricity flowing,	$Q = \int i dt.$
55. Amount of increase at rate $R$ ,	$I = \int R dt.$
56. Average value of a varying quantity $Q$ , from $x=a$ to $x=b$ :	$\bar{Q} = \frac{\int_a^b Q dx}{b-a}.$

## SOME IMPORTANT CONSTANTS

$\pi = 3.14159265,$

$\log_{10} \pi = .49714987.$

$e = 2.71828183,$

$\log_{10} e = .43429488.$

$\log_e 10 = \frac{1}{\log_{10} e} = 2.30258509.$

$1^{(\circ)} = 57^{\circ}.2957795$	$1^{\circ} = .01745329^{(\circ)}$
$1^{(\prime)} = 206264'' .806$	$1'' = 4.848137^{(\prime)} \times 10^{-6}$
1 ft. = 30.48 cm.	1 cm. = .0328 ft.
1 cu. ft. = 28317 cc.	1 cc. = .0000353 cu. ft.
1 lb. = .4536 kg.	1 kg. = 2.2046 lb.
1 gal. = 231 cu. in.	1 cu. ft. water weighs 62.4 lb.
1 acre = 10 sq. chains	1 ch. = 66 ft.

*The Earth's Radius*

Equatorial, 3963 mi.

| Polar, 3950 mi.

*Gravitational Acceleration* (sea-level, lat. 45°)

$g = 980.53 \text{ cm./sec.}^2$

$g = 32.17 \text{ ft./sec.}^2$

For any other latitude  $L^\circ$  multiply by  $(1 - .0026 \cos 2L)$ .*Newtonian Gravitational Constant* (Cf. § 102)In *C. G. S.* system,  $G = 6.66 \times 10^{-8}$ | In ft.-lb.-sec. system,  $G = 1.08 \times 10^{-9}$ *Distribution of Errors in Normal Case* $(E = \text{Probable error})$ 0 to  $E$ , 25%;  $E$  to  $2E$ , 16.1%;  $2E$  to  $3E$ , 6.9%.

More such values are given in the following table.

*Errors between Zero and Various Values*

Zero to ...	$\frac{1}{4} E$	$\frac{1}{2} E$	$\frac{3}{4} E$	$E$	$\frac{5}{4} E$	$\frac{3}{2} E$	$\frac{7}{4} E$	$2E$	$3E$	$4E$
Percentage	6.7	13.2	19.4	25.0	30.0	34.4	38.1	41.2	47.8	49.7

The *standard deviation*  $\sigma$  (or square root of the mean of the squares of all the deviations of  $n$  values from their average) should in the long run approach  $1.4826 E$ ; or

$$E = .6745 \sigma.$$

*Binomial Coefficients*

The coefficients in the expansion of  $(a+b)^n$  run as in Pascal's triangle: *e. g.*, for  $n=3$ , they are 1,3,3,1, etc. Each row is formed easily from that above.

				1					
				1		1			
				1	2	1			
				1	3	3	1		
				1	4	6	4	1	
				1	5	10	10	5	1

## SQUARES AND SQ. ROOTS — CUBES AND CUBE ROOTS

N	N²	$\sqrt{N}$	$\sqrt{10N}$		N³	$\sqrt[3]{N}$	$\sqrt[3]{10N}$	$\sqrt[5]{100N}$
1.0	1.00	1.0000	3.1623		1.000	1.0000	2.1544	4.6416
1.1	1.21	1.0488	3.3166		1.331	1.0323	2.2240	4.7914
1.2	1.44	1.0954	3.4641		1.728	1.0627	2.2894	4.9324
1.3	1.69	1.1402	3.6056		2.197	1.0914	2.3513	5.0658
1.4	1.96	1.1832	3.7417		2.744	1.1187	2.4101	5.1925
1.5	2.25	1.2247	3.8730		3.375	1.1447	2.4662	5.3133
1.6	2.56	1.2649	4.0000		4.096	1.1696	2.5198	5.4288
1.7	2.89	1.3038	4.1231		4.913	1.1935	2.5713	5.5397
1.8	3.24	1.3416	4.2426		5.832	1.2164	2.6207	5.6462
1.9	3.61	1.3784	4.3589		6.859	1.2386	2.6684	5.7489
2.0	4.00	1.4142	4.4721		8.000	1.2599	2.7144	5.8480
2.1	4.41	1.4491	4.5826		9.261	1.2806	2.7589	5.9439
2.2	4.84	1.4832	4.6904		10.648	1.3006	2.8020	6.0368
2.3	5.29	1.5166	4.7958		12.167	1.3200	2.8439	6.1269
2.4	5.76	1.5492	4.8990		13.824	1.3389	2.8845	6.2145
2.5	6.25	1.5811	5.0000		15.625	1.3572	2.9240	6.2996
2.6	6.76	1.6125	5.0990		17.576	1.3751	2.9625	6.3825
2.7	7.29	1.6432	5.1962		19.683	1.3925	3.0000	6.4633
2.8	7.84	1.6733	5.2915		21.952	1.4095	3.0366	6.5421
2.9	8.41	1.7029	5.3852		24.389	1.4260	3.0723	6.6191
3.0	9.00	1.7321	5.4772		27.000	1.4422	3.1072	6.6943
3.1	9.61	1.7607	5.5678		29.791	1.4581	3.1414	6.7679
3.2	10.24	1.7889	5.6569		32.768	1.4736	3.1748	6.8399
3.3	10.89	1.8166	5.7446		35.937	1.4888	3.2075	6.9104
3.4	11.56	1.8439	5.8310		39.304	1.5037	3.2396	6.9795
3.5	12.25	1.8708	5.9161		42.875	1.5183	3.2711	7.0473
3.6	12.96	1.8974	6.0000		46.656	1.5326	3.3019	7.1138
3.7	13.69	1.9235	6.0828		50.653	1.5467	3.3322	7.1791
3.8	14.44	1.9494	6.1644		54.872	1.5605	3.3620	7.2432
3.9	15.21	1.9748	6.2450		59.319	1.5741	3.3912	7.3061
4.0	16.00	2.0000	6.3246		64.000	1.5874	3.4200	7.3681
4.1	16.81	2.0248	6.4031		68.921	1.6005	3.4482	7.4290
4.2	17.64	2.0494	6.4807		74.088	1.6134	3.4760	7.4889
4.3	18.49	2.0736	6.5574		79.507	1.6261	3.5034	7.5478
4.4	19.36	2.0976	6.6333		85.184	1.6386	3.5303	7.6059
4.5	20.25	2.1213	6.7082		91.125	1.6510	3.5569	7.6631
4.6	21.16	2.1448	6.7823		97.336	1.6631	3.5830	7.7194
4.7	22.09	2.1679	6.8557		103.823	1.6751	3.6088	7.7750
4.8	23.04	2.1909	6.9282		110.592	1.6869	3.6342	7.8297
4.9	24.01	2.2136	7.0000		117.649	1.6985	3.6593	7.8837
5.0	25.00	2.2361	7.0711		125.000	1.7100	3.6840	7.9370
5.1	26.01	2.2583	7.1414		132.651	1.7213	3.7084	7.9896
5.2	27.04	2.2804	7.2111		140.608	1.7325	3.7325	8.0415
5.3	28.09	2.3022	7.2801		148.877	1.7435	3.7563	8.0927
5.4	29.16	2.3238	7.3485		157.464	1.7544	3.7798	8.1433
5.5	30.25	2.3452	7.4162		166.375	1.7652	3.8030	8.1932
5.6	31.36	2.3664	7.4833		175.616	1.7752	3.8259	8.2426
5.7	32.49	2.3875	7.5498		185.193	1.7863	3.8485	8.2913
5.8	33.64	2.4083	7.6158		195.112	1.7967	3.8709	8.3396
5.9	34.81	2.4290	7.6811		205.379	1.8070	3.8930	8.3872
6.0	36.00	2.4495	7.7460		216.000	1.8171	3.9149	8.4343



SQUARES AND SQ. ROOTS — CUBES AND CUBE ROOTS

N	N²	√N	√10 N	N³	∛N	∛10 N	∛100 N
6.0	36.00	2.4495	7.7460	216.000	1.8171	3.9149	8.4343
6.1	37.21	2.4698	7.8102	226.981	1.8272	3.9365	8.4809
6.2	38.44	2.4900	7.8740	238.328	1.8371	3.9579	8.5270
6.3	39.69	2.5100	7.9372	250.047	1.8469	3.9791	8.5726
6.4	40.96	2.5298	8.0000	262.144	1.8566	4.0000	8.6177
6.5	42.25	2.5495	8.0623	274.625	1.8663	4.0207	8.6624
6.6	43.56	2.5690	8.1240	287.496	1.8758	4.0412	8.7066
6.7	44.89	2.5884	8.1854	300.763	1.8852	4.0615	8.7503
6.8	46.24	2.6077	8.2462	314.432	1.8945	4.0817	8.7937
6.9	47.61	2.6268	8.3066	328.509	1.9038	4.1016	8.8366
7.0	49.00	2.6458	8.3666	343.000	1.9129	4.1213	8.8790
7.1	50.41	2.6646	8.4261	357.911	1.9220	4.1408	8.9211
7.2	51.84	2.6833	8.4853	373.248	1.9310	4.1602	8.9628
7.3	53.29	2.7019	8.5440	389.017	1.9399	4.1793	9.0041
7.4	54.76	2.7203	8.6023	405.224	1.9487	4.1983	9.0450
7.5	56.25	2.7386	8.6603	421.875	1.9574	4.2172	9.0856
7.6	57.76	2.7568	8.7178	438.976	1.9661	4.2358	9.1258
7.7	59.29	2.7749	8.7750	456.533	1.9747	4.2543	9.1657
7.8	60.84	2.7928	8.8318	474.552	1.9832	4.2727	9.2052
7.9	62.41	2.8107	8.8882	493.039	1.9916	4.2908	9.2443
8.0	64.00	2.8284	8.9443	512.000	2.0000	4.3089	9.2832
8.1	65.61	2.8460	9.0000	531.441	2.0083	4.3267	9.3217
8.2	67.24	2.8636	9.0554	551.368	2.0165	4.3445	9.3599
8.3	68.89	2.8810	9.1104	571.787	2.0247	4.3621	9.3978
8.4	70.56	2.8983	9.1652	592.704	2.0328	4.3795	9.4354
8.5	72.25	2.9155	9.2195	614.125	2.0408	4.3968	9.4727
8.6	73.96	2.9326	9.2736	636.056	2.0488	4.4140	9.5097
8.7	75.69	2.9496	9.3274	658.503	2.0567	4.4310	9.5464
8.8	77.44	2.9665	9.3808	681.472	2.0646	4.4480	9.5828
8.9	79.21	2.9833	9.4340	704.969	2.0723	4.4647	9.6190
9.0	81.00	3.0000	9.4868	729.000	2.0801	4.4814	9.6549
9.1	82.81	3.0166	9.5394	753.571	2.0878	4.4979	9.6905
9.2	84.64	3.0332	9.5917	778.688	2.0954	4.5144	9.7259
9.3	86.49	3.0496	9.6436	804.357	2.1029	4.5307	9.7610
9.4	88.36	3.0659	9.6954	830.584	2.1105	4.5468	9.7959
9.5	90.25	3.0822	9.7468	857.375	2.1179	4.5629	9.8305
9.6	92.16	3.0984	9.7980	884.736	2.1253	4.5789	9.8648
9.7	94.09	3.1145	9.8489	912.673	2.1327	4.5947	9.8990
9.8	96.04	3.1305	9.8995	941.192	2.1400	4.610	9.9329
9.9	98.01	3.1464	9.9499	970.299	2.1472	4.6261	9.9666
10.0	100.00	3.1623	10.0000	1000.000	2.1544	4.6416	10.0000

Notes: (I) To determine in which column to find a required root, use the pointing-off method, as in § 12. Thus

$$\sqrt{.0076} = \sqrt{.00\cdot76}; \text{ starts with 8; hence } .087178.$$

$$\sqrt[3]{.076} = \sqrt[3]{.076\cdot000}; \text{ starts with 4; hence } .42358.$$

$$\sqrt[3]{7600000} = \sqrt[3]{7\cdot600\cdot000}; \text{ starts with 1; hence } 196.61.$$

(II) For any third figure *f* in *N*, add *f* tenths of the difference between tabulated values; e.g.,  $\sqrt[3]{7.64} = 1.9661 + \frac{4}{10}(1.9747 - 1.9661) = 1.9695$ .

NATURAL LOGARITHMS (Base  $e$ )

$e^x$

N	0	1	2	3	4	5	6	7	8	9	x	$e^x$	
1.0	0.0	000	100	198	296	392	488	583	676	770	862	.05	1.051
1.1		953	*044	*133	*222	*310	*398	*484	*570	*655	*740	.10	1.105
1.2	0.1	823	906	989	*070	*151	*231	*311	*390	*469	*546	.15	1.162
1.3	0.2	624	700	776	852	.927	*001	*075	*148	*221	*293	.20	1.221
1.4	0.3	365	436	507	577	646	716	784	853	920	988	.25	1.284
1.5	0.4	055	121	187	253	318	382	447	511	574	637	.30	1.350
1.6		700	762	824	886	947	*008	*068	*128	*188	*247	.35	1.419
1.7	0.5	306	365	423	481	539	596	653	710	766	822	.40	1.492
1.8		878	933	988	*043	*098	*152	*216	*259	*313	*366	.45	1.568
1.9	0.6	419	471	523	575	627	678	729	780	831	881	.50	1.649
2.0		931	981	*031	*080	*129	*178	*227	*275	*324	*372	.6	1.822
2.1	0.7	419	467	514	561	608	655	701	747	793	839	.7	2.014
2.2		885	930	975	*020	*065	*109	*154	*198	*242	*286	.8	2.225
2.3	0.8	329	372	416	459	.502	544	587	629	671	713	.9	2.460
2.4		755	796	838	879	920	961	*002	*042	*083	*123	1.0	2.718
2.5	0.9	163	203	243	282	322	361	400	439	478	517	1.1	3.004
2.6		555	594	632	670	708	746	783	821	858	895	1.2	3.320
2.7		933	969	*006	*043	*080	*116	*152	*188	*225	*260	1.3	3.670
2.8	1.0	296	332	367	403	438	473	508	543	578	613	1.4	4.055
2.9		647	682	716	750	784	818	852	886	919	953	1.5	4.482
3.0		986	*019	*053	*086	*119	*151	*184	*217	*249	*282	1.6	4.953
3.1	1.1	314	346	378	410	442	474	506	537	569	600	1.7	5.474
3.2		632	663	694	725	756	787	817	848	878	909	1.8	6.050
3.3		939	969	*000	*030	*060	*090	*119	*149	*179	*208	1.9	6.686
3.4	1.2	238	267	296	326	355	384	413	441	470	499	2.0	7.389
3.5		523	556	585	613	641	669	698	726	754	782	2.1	8.166
3.6		809	837	865	892	920	947	975	*002	*029	*056	2.2	9.025
3.7	1.3	083	110	137	164	191	218	244	271	297	324	2.3	9.974
3.8		350	376	402	429	455	481	507	533	558	584	2.4	11.023
3.9		619	635	660	686	712	737	762	788	813	838	2.5	12.182
4.0		863	888	913	938	962	987	*012	*036	*061	*085	3.0	20.085
4.1	1.4	110	134	159	183	207	231	255	279	303	327	3.5	33.115
4.2		351	375	398	422	446	469	493	516	540	563	4.0	54.600
4.3		586	609	633	656	679	702	725	748	770	793	4.5	90.017
4.4		816	839	861	884	907	929	951	974	996	*019	5.0	148.413
4.5	1.5	041	063	085	107	129	151	173	195	217	239	5.5	244.692
4.6		261	282	304	326	347	369	390	412	433	454	6.0	403.429
4.7		476	497	518	539	560	581	602	623	644	655	6.5	665.13
4.8		686	707	728	748	769	790	810	831	851	872	7.0	1096.6
4.9		892	913	933	953	974	994	*014	*034	*054	*074	7.5	1808.0
5.0	1.6	094	114	134	154	174	194	214	233	253	273	8.0	2981.0

Notes: When given a larger or smaller value of N, express it in Scientific Notation (§ 167).

Thus  $1720 = 1.72 \times 10^3$ .  $\therefore \log 1720 = \log 1.72 + 3 \log 10$ .

When given a logarithm outside the table, reverse this operation.

MULTIPLES OF  $\log_e 10$

$\log 10 = 2.3026$	$4 \log 10 = 9.2103$	$-\log 10 = .6974 - 3$
$2 \log 10 = 4.6052$	$5 \log 10 = 11.5129$	$-2 \log 10 = .3948 - 5$
$3 \log 10 = 6.9078$	$6 \log 10 = 13.8155$	$-3 \log 10 = .0922 - 7$

Note: Don't interpolate in this small table. Locate further values of  $x$  among logs in the main table, and read  $e^x$  from N-column.

NATURAL LOGARITHMS (Base  $e$ )

$e^{-x}$

N	0	1	2	3	4	5	6	7	8	9	
5.0	1.6	094	114	134	154	174	194	214	233	253	273
5.1		292	312	332	351	371	390	409	429	448	467
5.2		487	506	525	544	563	582	601	620	639	658
5.3		677	696	715	734	752	771	790	808	827	845
5.4		864	882	901	919	938	956	974	993	*011	*029
5.5	1.7	047	066	084	102	120	138	156	174	192	210
5.6		228	246	263	281	299	317	334	352	370	387
5.7		405	422	440	457	475	492	510	527	544	561
5.8		579	596	613	630	647	664	681	699	716	733
5.9		750	766	783	800	817	834	851	867	884	901
6.0		918	934	951	967	984	*001	*017	*034	*050	*066
6.1	1.8	083	099	116	132	148	165	181	197	213	229
6.2		245	262	278	294	310	326	342	358	374	390
6.3		405	421	437	453	469	485	500	516	532	547
6.4		563	579	594	610	625	641	656	672	687	703
6.5		718	733	749	764	779	795	810	825	840	856
6.6		871	886	901	916	931	946	961	976	991	*006
6.7	1.9	021	036	051	066	081	095	110	125	140	155
6.8		169	184	199	213	228	242	257	272	286	301
6.9		315	330	344	359	373	387	402	416	430	445
7.0		459	473	488	502	516	530	544	559	573	587
7.1		601	615	629	643	657	671	685	699	713	727
7.2		741	755	769	782	796	810	823	838	851	865
7.3		879	892	906	920	933	947	961	974	988	*001
7.4	2.0	015	028	042	055	069	082	096	109	122	136
7.5		149	162	176	189	202	215	229	242	255	268
7.6		281	295	308	321	334	347	360	373	386	399
7.7		412	425	438	451	464	477	490	503	516	528
7.8		541	554	567	580	592	605	618	631	643	656
7.9		669	681	694	707	719	732	744	757	769	782
8.0		794	807	819	832	844	857	869	882	894	906
8.1		919	931	943	956	968	980	992	*005	*017	*029
8.2	2.1	041	054	066	080	090	102	114	126	138	150
8.3		163	175	187	199	211	223	235	247	258	270
8.4		282	294	306	318	330	342	353	365	377	389
8.5		401	412	424	436	448	460	471	483	494	506
8.6		518	529	541	552	564	576	587	599	610	622
8.7		633	645	656	668	679	691	702	713	725	736
8.8		748	759	770	782	793	804	815	827	838	849
8.9		861	872	883	894	905	917	928	939	950	961
9.0		972	983	994	*006	*017	*028	*039	*050	*061	*072
9.1	2.2	083	094	105	116	127	137	148	159	170	181
9.2		192	203	214	225	235	246	257	268	279	289
9.3		300	311	322	332	343	354	364	375	386	396
9.4		407	418	428	439	450	460	471	481	492	502
9.5		513	523	534	544	555	565	576	586	597	607
9.6		618	628	638	649	659	670	680	690	701	711
9.7		721	732	742	752	762	773	783	793	803	814
9.8		824	834	844	854	865	875	885	895	905	915
9.9		925	935	946	956	966	976	986	996	*006	*016
10.	2.3	026	036	046	056	066	076	086	096	106	115

x	$e^{-x}$
.05	.951
.10	.905
.15	.861
.20	.819
.25	.779
.30	.741
.35	.705
.40	.670
.45	.638
.50	.606
.6	.549
.7	.496
.8	.449
.9	.406
1.0	.368
1.1	.333
1.2	.301
1.3	.272
1.4	.247
1.5	.223
1.6	.202
1.7	.183
1.8	.165
1.9	.149
2.0	.135
2.1	.122
2.2	.111
2.3	.100
2.4	.091
2.5	.082
3.0	.050
3.5	.030
4.0	.018
4.5	.011
5.0	.007
5.5	.004
6.0	.0024
6.5	.0015
7.0	.0009
7.5	.0005
8.0	.0003

Note: Further values:  $e^{-x} = \frac{1}{e^x}$ .  
See N column for  $e^x$  values, x being in body of Table.

## Trigonometric Functions (Radian Measure)

$\theta(r)$	$\sin \theta$	$\cos \theta$	$\tan \theta$	$\theta(r)$	$\sin \theta$	$\cos \theta$	$\tan \theta$
.00	.000	1.000	.000	1.0	.841	.540	1.557
.05	.050	.999	.050	1.5	.997	.071	14.101
.10	.100	.995	.100	2.0	.909	-.416	-2.185
.15	.149	.989	.151	2.5	.598	-.801	-.747
.20	.199	.980	.203	3.0	.141	-.990	-.143
.25	.247	.969	.255	3.5	-.351	-.936	.375
.30	.296	.955	.309	4.0	-.757	-.654	1.158
.35	.343	.939	.365	4.5	-.978	-.211	4.637
.40	.389	.921	.423	5.0	-.959	.284	-3.379
.45	.435	.900	.483	5.5	-.706	.709	-.996
.50	.479	.878	.546	6.0	-.279	.960	-.291
.60	.565	.825	.684	7.0	.657	.754	.871
.70	.644	.765	.842	8.0	.989	-.146	-6.800
.80	.717	.697	1.030	9.0	.412	-.911	-.452
.90	.783	.622	1.260	10.	-.544	-.839	.648

## Radians to Degrees

$$1(r) = 57^{\circ} 17' 44''.806$$

	RADIANS			TENTHS			HUNDRETHS			THOUSANDTHS		TEN-THOUSANDTHS	HUNDRED-THOUSANDTHS		
	°	'	''	°	'	''	°	'	''	°	'	''	'	''	''
1	57	17	45	5	43	46	0	34	23	0	3	26	0	21	2
2	114	35	30	11	27	33	1	8	45	0	6	53	0	41	4
3	171	53	14	17	11	19	1	43	08	0	10	19	1	02	6
4	229	10	59	22	55	06	2	17	31	0	13	45	1	22	8
5	286	28	44	28	38	52	2	51	53	0	17	11	1	43	10
6	343	46	29	34	22	39	3	26	16	0	20	38	2	04	12
7	401	4	14	40	6	25	4	0	38	0	24	04	2	24	14
8	458	21	58	45	50	12	4	35	01	0	27	30	2	45	16
9	515	39	43	51	33	58	5	9	24	0	30	56	3	06	19

## Degrees to Radians

This change is not often necessary. To make it, multiply out, using

$$1^{\circ} = .017453293(r), \quad 1' = .000290888(r), \quad 1'' = .000004848(r)$$

TRIGONOMETRIC FUNCTIONS  
and their common logarithms

An- gle	SINE		TANGENT		COTANGENT		COSINE		
	Value	log	Value	log	Value	log	Value	log	
0°	.0000		.0000				1.0000	0.0000	90°
1°	.0175	8.2419	.0175	8.2419	57.290	1.7581	.9998	9.9999	89°
2°	.0349	8.5428	.0349	8.5431	28.636	1.4569	.9994	9.9997	88°
3°	.0523	8.7188	.0524	8.7194	19.081	1.2806	.9986	9.9994	87°
4°	.0698	8.8436	.0699	8.8446	14.301	1.1554	.9976	9.9989	86°
5°	.0872	8.9403	.0875	8.9420	11.430	1.0580	.9962	9.9983	85°
6°	.1045	9.0192	.1051	9.0216	9.5144	0.9784	.9945	9.9976	84°
7°	.1219	9.0859	.1228	9.0891	8.1443	0.9109	.9925	9.9968	83°
8°	.1392	9.1436	.1405	9.1478	7.1154	0.8522	.9903	9.9958	82°
9°	.1564	9.1943	.1584	9.1997	6.3138	0.8003	.9877	9.9946	81°
10°	.1736	9.2397	.1763	9.2463	5.6713	0.7537	.9848	9.9934	80°
11°	.1908	9.2806	.1944	9.2887	5.1446	0.7113	.9816	9.9919	79°
12°	.2079	9.3179	.2126	9.3275	4.7046	0.6725	.9781	9.9904	78°
13°	.2250	9.3521	.2309	9.3634	4.3315	0.6366	.9744	9.9887	77°
14°	.2419	9.3837	.2493	9.3968	4.0108	0.6032	.9703	9.9869	76°
15°	.2588	9.4130	.2679	9.4281	3.7321	0.5719	.9659	9.9849	75°
16°	.2756	9.4403	.2867	9.4575	3.4874	0.5425	.9613	9.9828	74°
17°	.2924	9.4659	.3057	9.4853	3.2709	0.5147	.9563	9.9806	73°
18°	.3090	9.4900	.3249	9.5118	3.0777	0.4882	.9511	9.9782	72°
19°	.3256	9.5126	.3443	9.5370	2.9042	0.4630	.9455	9.9757	71°
20°	.3420	9.5341	.3640	9.5611	2.7475	0.4389	.9397	9.9730	70°
21°	.3584	9.5543	.3839	9.5842	2.6051	0.4158	.9336	9.9702	69°
22°	.3746	9.5736	.4040	9.6064	2.4751	0.3936	.9272	9.9672	68°
23°	.3907	9.5919	.4245	9.6279	2.3559	0.3721	.9205	9.9640	67°
24°	.4067	9.6093	.4452	9.6486	2.2460	0.3514	.9135	9.9607	66°
25°	.4226	9.6259	.4663	9.6687	2.1445	0.3313	.9063	9.9573	65°
26°	.4384	9.6418	.4877	9.6882	2.0503	0.3118	.8988	9.9537	64°
27°	.4540	9.6570	.5095	9.7072	1.9626	0.2928	.8910	9.9499	63°
28°	.4695	9.6716	.5317	9.7257	1.8807	0.2743	.8829	9.9459	62°
29°	.4848	9.6856	.5543	9.7438	1.8040	0.2562	.8746	9.9418	61°
30°	.5000	9.6990	.5774	9.7614	1.7321	0.2386	.8660	9.9375	60°
31°	.5150	9.7118	.6009	9.7788	1.6643	0.2212	.8572	9.9331	59°
32°	.5299	9.7242	.6249	9.7958	1.6003	0.2042	.8480	9.9284	58°
33°	.5446	9.7361	.6494	9.8125	1.5399	0.1875	.8387	9.9236	57°
34°	.5592	9.7476	.6745	9.8290	1.4826	0.1710	.8290	9.9186	56°
35°	.5736	9.7586	.7002	9.8452	1.4281	0.1548	.8192	9.9134	55°
36°	.5878	9.7692	.7265	9.8613	1.3764	0.1387	.8090	9.9080	54°
37°	.6018	9.7795	.7536	9.8771	1.3270	0.1229	.7986	9.9023	53°
38°	.6157	9.7893	.7813	9.8928	1.2799	0.1072	.7880	9.8965	52°
39°	.6293	9.7989	.8098	9.9084	1.2349	0.0916	.7771	9.8905	51°
40°	.6428	9.8081	.8391	9.9238	1.1918	0.0762	.7660	9.8843	50°
41°	.6561	9.8169	.8693	9.9392	1.1504	0.0608	.7547	9.8778	49°
42°	.6691	9.8255	.9004	9.9544	1.1106	0.0456	.7431	9.8711	48°
43°	.6820	9.8338	.9325	9.9697	1.0724	0.0303	.7314	9.8641	47°
44°	.6947	9.8418	.9657	9.9848	1.0355	0.0152	.7198	9.8569	46°
45°	.7071	9.8495	1.0000	0.0000	1.0000	0.0000	.7071	9.8495	45°
	Value	log	Value	log	Value	log	Value	log	An- gle
	COSINE		COTANGENT		TANGENT		SINE		

Note:  $\log \sec x = -\log \cos x$ ,

$\log \csc x = -\log \sin x$ .

## COMMON LOGARITHMS (Base 10)

N	0	1	2	3	4	5	6	7	8	9	u. d.
10	0000	0043	0086	0128	0170	0212	0253	0294	0334	0374	4.2
11	0414	0453	0492	0531	0569	0607	0645	0682	0719	0755	3.8
12	0792	0828	0864	0899	0934	0969	1004	1038	1072	1106	3.5
13	1139	1173	1206	1239	1271	1303	1335	1367	1399	1430	3.2
14	1461	1492	1523	1553	1584	1614	1644	1673	1703	1732	3.0
15	1761	1790	1818	1847	1875	1903	1931	1959	1987	2014	2.8
16	2041	2068	2095	2122	2148	2175	2201	2227	2253	2279	2.6
17	2304	2330	2355	2380	2405	2430	2455	2480	2504	2529	2.5
18	2553	2577	2601	2625	2648	2672	2695	2718	2742	2765	2.4
19	2788	2810	2833	2856	2878	2900	2923	2945	2967	2989	2.2
20	3010	3032	3054	3075	3096	3118	3139	3160	3181	3201	2.1
21	3222	3243	3263	3284	3304	3324	3345	3365	3385	3404	2.0
22	3424	3444	3464	3483	3502	3522	3541	3560	3579	3598	1.9
23	3617	3636	3655	3674	3692	3711	3729	3747	3766	3784	1.8
24	3802	3820	3838	3856	3874	3892	3909	3927	3945	3962	1.8
25	3979	3997	4014	4031	4048	4065	4082	4099	4116	4133	1.7
26	4150	4166	4183	4200	4216	4232	4249	4265	4281	4298	1.6
27	4314	4330	4346	4362	4378	4393	4409	4425	4440	4456	1.6
28	4472	4487	4502	4518	4533	4548	4564	4579	4594	4609	1.5
29	4624	4639	4654	4669	4683	4698	4713	4728	4742	4757	1.5
30	4771	4786	4800	4814	4829	4843	4857	4871	4886	4900	1.4
31	4914	4928	4942	4955	4969	4983	4997	5011	5024	5038	1.4
32	5051	5065	5079	5092	5105	5119	5132	5145	5159	5172	1.3
33	5185	5198	5211	5224	5237	5250	5263	5276	5289	5302	1.3
34	5315	5328	5340	5353	5366	5378	5391	5403	5416	5428	1.3
35	5441	5453	5465	5478	5490	5502	5514	5527	5539	5551	1.2
36	5563	5575	5587	5599	5611	5623	5635	5647	5658	5670	1.2
37	5682	5694	5705	5717	5729	5740	5752	5763	5775	5786	1.2
38	5798	5809	5821	5832	5843	5855	5866	5877	5888	5899	1.1
39	5911	5922	5933	5944	5955	5966	5977	5988	5999	6010	1.1
40	6021	6031	6042	6053	6064	6075	6085	6096	6107	6117	1.1
41	6128	6138	6149	6160	6170	6180	6191	6201	6212	6222	1.0
42	6232	6243	6253	6263	6274	6284	6294	6304	6314	6325	1.0
43	6335	6345	6355	6365	6375	6385	6395	6405	6415	6425	1.0
44	6435	6444	6454	6464	6474	6484	6493	6503	6513	6522	1.0
45	6532	6542	6551	6561	6571	6580	6590	6599	6609	6618	1.0
46	6628	6637	6646	6656	6665	6675	6684	6693	6702	6712	.9
47	6721	6730	6739	6749	6758	6767	6776	6785	6794	6803	.9
48	6812	6821	6830	6839	6848	6857	6866	6875	6884	6893	.9
49	6902	6911	6920	6928	6937	6946	6955	6964	6972	6981	.9
50	6990	6998	7007	7016	7024	7033	7042	7050	7059	7067	.9
51	7076	7084	7093	7101	7110	7118	7126	7135	7143	7152	.8
52	7160	7168	7177	7185	7193	7202	7210	7218	7226	7235	.8
53	7243	7251	7259	7267	7275	7284	7292	7300	7308	7316	.8
54	7324	7332	7340	7348	7356	7364	7372	7380	7388	7396	.8

*Note:* The column u. d. (=unit difference) may be used in interpolating. Multiply the u. d. value by figure in 4th place of given number and add to logarithm read from table for first 3 figures of number.

COMMON LOGARITHMS

N	0	1	2	3	4	5	6	7	8	9	u. d.
55	7404	7412	7419	7427	7435	7443	7451	7459	7466	7474	.8
56	7482	7490	7497	7505	7513	7520	7528	7536	7543	7551	.8
57	7559	7566	7574	7582	7589	7597	7604	7612	7619	7627	.8
58	7634	7642	7649	7657	7664	7672	7679	7686	7694	7701	.7
59	7709	7716	7723	7731	7738	7745	7752	7760	7767	7774	.7
60	7782	7789	7796	7803	7810	7818	7825	7832	7839	7846	.7
61	7853	7860	7868	7875	7882	7889	7896	7903	7910	7917	.7
62	7924	7931	7938	7945	7952	7959	7966	7973	7980	7987	.7
63	7993	8000	8007	8014	8021	8028	8035	8041	8048	8055	.7
64	8062	8069	8075	8082	8089	8096	8102	8109	8116	8122	.7
65	8129	8136	8142	8149	8156	8162	8169	8176	8182	8189	.7
66	8195	8202	8209	8215	8222	8228	8235	8241	8248	8254	.7
67	8261	8267	8274	8280	8287	8293	8299	8306	8312	8319	.6
68	8325	8331	8338	8344	8351	8357	8363	8370	8376	8382	.6
69	8388	8395	8401	8407	8414	8420	8426	8432	8439	8445	.6
70	8451	8457	8463	8470	8476	8482	8488	8494	8500	8506	.6
71	8513	8519	8525	8531	8537	8543	8549	8555	8561	8567	.6
72	8573	8579	8585	8591	8597	8603	8609	8615	8621	8627	.6
73	8633	8639	8645	8651	8657	8663	8669	8675	8681	8686	.6
74	8692	8698	8704	8710	8716	8722	8727	8733	8739	8745	.6
75	8751	8756	8762	8768	8774	8779	8785	8791	8797	8802	.6
76	8808	8814	8820	8825	8831	8837	8842	8848	8854	8859	.6
77	8865	8871	8876	8882	8887	8893	8899	8904	8910	8915	.6
78	8921	8927	8932	8938	8943	8949	8954	8960	8965	8971	.6
79	8976	8982	8987	8993	8998	9004	9009	9015	9020	9025	.5
80	9031	9036	9042	9047	9053	9058	9063	9069	9074	9079	.5
81	9085	9090	9096	9101	9106	9112	9117	9122	9128	9133	.5
82	9138	9143	9149	9154	9159	9165	9170	9175	9180	9186	.5
83	9191	9196	9201	9206	9212	9217	9222	9227	9232	9238	.5
84	9243	9248	9253	9258	9263	9269	9274	9279	9284	9289	.5
85	9294	9299	9304	9309	9315	9320	9325	9330	9335	9340	.5
86	9345	9350	9355	9360	9365	9370	9375	9380	9385	9390	.5
87	9395	9400	9405	9410	9415	9420	9425	9430	9435	9440	.5
88	9445	9450	9455	9460	9465	9469	9474	9479	9484	9489	.5
89	9494	9499	9504	9509	9513	9518	9523	9528	9533	9538	.5
90	9542	9547	9552	9557	9562	9566	9571	9576	9581	9586	.5
91	9590	9595	9600	9605	9609	9614	9619	9624	9628	9633	.5
92	9638	9643	9647	9652	9657	9661	9666	9671	9675	9680	.5
93	9685	9689	9694	9699	9703	9708	9713	9717	9722	9727	.5
94	9731	9736	9741	9745	9750	9754	9759	9763	9768	9773	.5
95	9777	9782	9786	9791	9795	9800	9805	9809	9814	9818	.5
96	9823	9827	9832	9836	9841	9845	9850	9854	9859	9863	.5
97	9868	9872	9877	9881	9886	9890	9894	9899	9903	9908	.4
98	9912	9917	9921	9926	9930	9934	9939	9943	9948	9952	.4
99	9956	9961	9965	9969	9974	9978	9983	9987	9991	9996	.4

Generated for eijkc (University of Virginia) on 2016-10-09 01:50 GMT / http://hdl.handle.net/2027/nyp.33433069104713  
 Public Domain, Google-digitized / http://www.hathitrust.org/access\_use#pd-google

## ABBREVIATIONS AND SYMBOLS

<p><b>A.</b>, amount, area, attraction.  <b>A. P.</b>, arithmetical progression.  <b>C. I. L.</b>, compound interest law.  <b>G. P.</b>, geometrical progression.  <b>M.</b>, mass, moment, momentum.  <b>P.</b>, pressure, principal, probability.  <b>P. V.</b>, present value.  <b>R. P. M.</b>, revolutions per minute.  <b>S. H. M.</b>, simple harmonic motion.  <b>V.</b>, value, volume, speed (velocity).  <math>\frac{d}{dx}</math>, derivative (as to <math>x</math>).  <math>\log_b</math>, logarithm of ..., base <math>b</math>.  <b>sin</b>, <b>cos</b>, sine, cosine.  <b>tan</b>, <b>ctn</b>, tangent, cotangent.  <b>sec</b>, <b>csc</b>, secant, cosecant.  <b>C<sub>n</sub></b>, <b>r</b>, <b>P<sub>n</sub></b>, <b>r</b>. (See §§ 327, 330.)  <b>Cis</b>, cosine + <math>i</math> sine. (See § 350.)</p>	<p><math>\triangle</math>, triangle.  <math>\Delta</math> (delta), increment.  <math>\theta</math> (theta), polar angle.  <math>\omega</math> (omega), angular speed.  <math>\alpha</math> (alpha), angular acceleration.  <math>n!</math> factorial <math>n</math>.  <math>1^{(r)}</math>, radian.  <math>i</math>, imaginary unit (<math>\sqrt{-1}</math>).  <math> \dots </math>, absolute value of ....  <math>\int</math>, integral.  <math>\rightarrow, \doteq</math>, approaches the limit ....  <math>L</math>, limit of ..., as <math>\Delta x \rightarrow 0</math>.  <math>\Delta x \rightarrow 0</math>.  <math>\infty</math>, infinity.  <math>\rightarrow \infty</math>, increases without limit.  <math>&lt;</math>, is less than (algebraically).  <math>&gt;</math>, is greater than (algebraically).</p>
---	---



## INDEX

- Abbreviations, List of, 508.  
 Abrupt Extremes, 120.  
 Abscissa, 271, 351.  
 Absolute value, 464.  
 Acceleration, 24, 74, 81, 104, 132, 277, 346, 377.  
 Addition formulas for sine and cosine, 381, 488.  
 Amortization of debts, 422 *ff.*  
 Analytic geometry, 279-325, 343, 365, 375, 386, 402-406.  
 Angle between curves, 164, 386.  
 Angular speed, 56, 345 *ff.*, 377.  
 Annuities, 422-426.  
 Arc and angle, 349; chord, 63, 361.  
 Area: of a surface, 88, 169, 400; of a triangle, 218, 489; under a curve, 29, 64, 136, 393, 410.  
 Arithmetical progression, 415.  
 Arrangements, 440.  
 Artillery, 454. *See* Projectile.  
 Asymptotes, 308, 312, 319, 356.  
 Atmospheric pressure, 4; 251, 264.  
 Attraction of a rod, 150.  
 Average value, 24-31, 408-412.  
 Axes of coördinates, 271, 291, 343.  
 Axis of a curve, 294, 301, 307.  
  
 Bacterial growth, 16, 247, 255, 264.  
 Beams, 63, 105, 134, 173, 325, 328.  
 Binomial Distribution, Normal, 452.  
 Binomial theorem, 431, 444.  
 Bonds, Valuation of, 425.  
 Bridges, 171 *ff.*, 290, 298, 303, 325.  
 Bullet. *See* Projectile.  
  
 Calculation of tables, 185, 225, 430.  
 Calculus, 151; 76-155, 188, 229 *ff.*, 255-267, 360-362, 372-385, 388, 392-414, 428-433, 456-458, 473.  
 Cartesian geometry. *See* Analytic G.  
 Chance. *See* Probability.  
 Characteristic, 193-200.  
 Circle: area, 89; equation, 288.  
 Circular motion, 345-348.  
 Co-function, 167, 351 *ff.*  
 Combinations, 442-445.  
 Completing the square, 35, 289, 326.  
 Complex numbers, 460-471.  
 Component, 169-172, 275, 383.  
 Compound interest, 209-213, 236 *ff.*, 418-426. *C. I. Law*, 243-251, 262.  
 Computation, Logarithmic, 192-223.  
 Concurrent lines, 321.  
 Cone, 88, 323.  
 Conic, 316, 323, 327.  
 Constants, 49, 83, 84, 127, 392, 498.  
 Contour lines, 29.  
 Coördinates, 271-325, 343-350, 365, 463-465.  
 Cosecant, 352, 368.  
 Cosine, 167-171, 177-182, 351-362, 368, 382. *C. Law*, 177-182.  
 Cotangent, 167, 352, 368.  
 Cubes, roots, etc., 21, 500.  
 Curvature, 175.  
 Cycloid, 375.  
 Cylinder, 88.  
  
 Damped oscillations, 378.  
 Definite integrals, 392-414.  
 Degree-measure (calculus), 362, 373.  
 Delta ( $\Delta$ ), 19, 43, 59, 78 *ff.*, 255, 361.  
 Dependent variable. *See* Function.  
 Depreciation, 213, 240.  
 Depression, Angle of, 164.  
 Derivatives, 78-125, 255-267, 360, 372, 493; higher, 105; partial, 406.  
 Derived curves, 107.  
 Descartes, 284.  
 Die-away curve, 244, 246.  
 Differential, 121-123, 151.  
 Differentiation, 76-125, 255-267, 360, 372, 406, 472.  
 Diminishing a root, 334-338  
 Direction, 65, 274, 281, 343, 486.  
 Directrix, 293.  
 Discovering laws, 50, 253, 436.  
 Discriminant, 328.

- Distance: between points, 279, 344; traveled, 25, 144, 275, 375.
- Division: by zero, 47; of complex numbers, 462, 466; synthetic, 330, 487.
- Double integration, 403.
- e** (Napierian base), 238, 241.
- Electric current, 29, 50, 233, 244, 264, 359, 378, 380, 470.
- Elevation, 259; Angle of, 164.
- Ellipse, 299–306.
- Empirical laws, 50, 253, 436.
- Engravers' charts, 312.
- Equation of curve, 283 *ff.*
- Equations, Solution of, 35–41, 212, 326–342, 370.
- Equilibrium, 158, 171 *ff.*
- Errors, 91, 453–459.
- Estimates, 189, 349. *See* Graphical solution; Graphs.
- Exponential equations, 212, 253.
- Exponential functions, 244 *ff.*, 378; relation to sine and cosine, 433.
- Exponents, 98, 190, 212, 433, 434.
- Extremes. *See* Maxima and Minima.
- Factorability of a quadratic**, 329.
- Factorials, 429, 440–444.
- Factors of polynomials, 92, 329–338.
- Falling bodies, 42, 45, 50, 126, 153.
- Flexion, 105.
- Focus (foci), 293, 301, 307.
- Force problems, 157, 169–173.
- Formulas, 42, 44, 48, 50, 76, 88, 128, 142, 209, 313, 492; for roots of a quadratic, 326; Addition, 381.
- Fourier series, 434–436.
- Fraction, Derivative of, 85, 265, 372.
- Fractional exponents, 98, 119.
- Function: definition, 5; notation, 73; kinds, 45, 78, 82, 104, 110, 127, 160, 163, 167, 198, 236, 244, 324, 350, 413, 433, 473, 483.
- Fundamental theorem of Integral Calculus, 394.
- Gas laws, 50, 61, 102, 116, 233, 258.
- Geometrical principles, 34, 63–66, 88, 141 *ff.*, 160, 185, 279 *ff.*
- Geometrical progression, 416–426.
- Geometrical representation of complex numbers, 463.
- Grade. *See* Slope.
- Graphical representation: of forces, 157; of functions, *see* Graphs.
- Graphical solution: of equations, 37; of triangles, 157.
- Graphs, 3–57, 79, 107, 246, 318, 355, 365; logarithmic, etc., 247–255; of function of two variables, 402.
- Half-angles, 218, 385.
- Horizontal tangents, 92, 120, 407.
- Horner's method, 337.
- Hyperbola, 306–312.
- Hyperbolic formulas, 313.
- Identities, Trigonometric, 368–371, 381–385, 387, 433.
- Imaginaries, 38, 318, 329, 434, 460 *ff.*
- Implicit functions, 116, 295, 324.
- Inclination, 163, 281.
- Increasing test, 80, 94.
- Increment, 43, 80, 89.
- Independent variables, 6, 406.
- Indirect differentiation, 110, 111, 257, 362.
- Infinite, 48, 356, 493; series, 427 *ff.*
- Infinitesimal analysis, 144, 395–401.
- Inflection, Points of, 107.
- Instantaneous. *See* Direction, Rate, Slope, Speed.
- Insurance. *See* Life Insurance.
- Integral, integration, 126–155, 258, 276, 379, 388–414, 427, 494 *ff.*
- Interpolate, 11, 18, 201.
- Intersections, 318, 321, 329.
- Investment, 210–214, 342, 418–426.
- Involute, 375, 376.
- Irrational roots, 35–41, 334, 337 *ff.*
- Isolating a root, 340.
- Laws. *See* Compound Interest, Cosine, Discovery, Power, Sine.
- Least squares, 456–458.
- Leibnitz, 151, 396.
- Length of a curve, 63 *ff.*, 399, 400.
- Life Insurance, 420.
- Limit, 58–75, 78, 193, 395, 427, 486.
- Limit of  $(1+1/z)^z$ , 238.

- Linear equations**, 35, 45, 50, 87, 253, 286, 319.  
**Locus (loci)**, 283 *ff.*  
**Logarithm**, 193–226, 241, 247–260, 427, 434; to any base, 222.  
**Logarithmic differentiation**, 260 *ff.*  
**Logarithmic plotting**, 252.  
**Logarithmic solution of triangles**, 216–222.  
  
**Maclaurin series**, 428 *ff.*  
**Mantissa**, 193–200.  
**Mass**, 150, 398.  
**Mathematical analysis**, 1.  
**Maxima and Minima**, 32, 94–98, 108, 120; for two variables, 406.  
**Mean ordinate**, 24–31, 409.  
**Mean value**, 24–31, 408–412.  
**Measurement, Errors of**, 91, 453 *ff.*  
**Mensuration formulas**, 88, 492.  
**Midpoint**, 280.  
**Moment of a force**, 172, 398.  
**Momentum**, 26, 137, 393.  
**Motion**, 58, 62, 78, 104, 132, 272–278, 344–346, 374–377.  
**Multiple-angle formulas**, 383.  
  
**n-th roots**, 469.  
**Napier**, 225.  
**Napierian base ( $e$ )**, 238, 241.  
**Natural logarithms**, 241–243.  
**Negative rates, etc.**, 59, 61, 68, 80.  
**Newton**, 151, 339, 396.  
**Nomographic charts**, 224, 252.  
**Normal probability curve**, 453–459.  
**Notation**, 43, 72–73, 104, 121, 134, 190, 193, 363, 508.  
  
**Oblique triangles**, 176–183, 216–222.  
**Obtuse angles**, 180–182, 351, 357 *ff.*  
**Operations, with complex numbers**, 462, 466–470; with logarithms, 199, 203.  
**Ordinate**, 7, 25, 271.  
**Origin**, 271, 343.  
**Original meaning of  $f$** , 143, 396.  
**Oscillations**, 359, 376–378, 435.  
  
**Parabola**, 293–299, 313, 316.  
**Parabolic formulas**, 313.  
**Partial derivatives**, 406.  
  
**Path of motion**, 272, 316, 344.  
**Pendulum**, 45, 56, 73, 360, 411.  
**Percentage**, 91, 209, 236–251, 455.  
**Periodic oscillations**, 359.  
**Permutations**, 440.  
**Perpendicularity test**, 282.  
**Pistons**, 29, 174, 233, 258.  
**Planets**, 50, 121, 180, 255, 302.  
**Planimeter**, 30.  
**Point-slope equation**, 319.  
**Polar axis**, 343.  
**Polar coördinates**, 343–350, 365, 465.  
**Polynomials**, 37 *ff.*, 85, 436.  
**Power laws**, 82, 100, 252–253, 313.  
**Power series**, 427 *ff.*  
**Present value**, 422.  
**Pressure, Fluid**, 146, 175, 188, 232.  
**Prismoid formula**, 411.  
**Probability**, 447–458.  
**Probable error**, 453.  
**Product, Derivative of a**, 85, 265, 375, 379.  
**Products and sums, Trig'metric**, 387.  
**Progressions**, 415–426.  
**Projectile**, 42, 50, 58, 76, 125, 132, 277, 316, 370, 454.  
**Projection**, 168–170, 305.  
**Proportional parts**, 18, 201.  
**Protractor**, 156 *ff.*  
  
**Quadrants**, 352, 354.  
**Quadratic equation**, 35, 326–327.  
  
**Radian**, 347, 356, 360, 400, 429, 434.  
**Radium, Decomposition of**, 16, 241.  
**Radius vector**, 343, 365.  
**Rates**, 13–16, 42, 60, 76, 79, 105, 108; of growing areas, etc., 135–150; percentage, 236–251; related, 114–118; reversed, 126–151.  
**Rational roots**, 331–333.  
**Real number system**, 38, 460.  
**Reciprocals**, 48, 99, 283, 352.  
**Rectangular coördinates**, 271–325, 374, 463.  
**Rectangular hyperbola**, 312 *ff.*  
**Reducing to acute angles**, 357–358.  
**Related rates**, 114.  
**Repeated differentiation**, 105–108; integration, 131 *ff.*, 277, 403.  
**Resultant force**, 158 *ff.*; speed, 275.

- Roots, of an equation, 35-41, 326-341, 370; Tables of, 21, 500.  
 Rotating a curve  $90^\circ$ , 297, 327.  
 Rotating fluid, 128, 295, 296.
- Scales, 11, 224, 248-254.  
 Scientific Notation, 190, 242.  
 Secant, 65 *ff.*; 352, 368, 373.  
 Sections of a surface, 405.  
 Segments, 141, 153, 166, 492.  
 Semi-logarithmic plotting, 247 *ff.*  
 Series, 427-435.  
 Simple harmonic motion, 376.  
 Simpson's rule, 409, 490.  
 Simultaneous equations, 52, 321, 437, 458.  
 Simultaneous triangles, 184.  
 Sine, 160, 180-182, 214, 217, 351-362, 382. *S. law*, 178-182, 216.  
 Slide rule, 223, 247-252.  
 Sliders. *See* Translators.  
 Slope, 67, 68, 79, 107, 163, 280, 405.  
 Solution. *See* Equation, Triangle.  
 Sound ranging, 310.  
 Speed, 25, 58, 76 *ff.*, 274, 486.  
 Sphere, 88, 141, 146.  
 Squares, roots, etc., 21, 500.  
 Straight lines, 45, 253, 286, 319.  
 Successive triangles, 184.  
 Summaries, 53, 74, 123, 151, 154, 185, 225, 227, 267, 323, 341, 366, 389, 413, 438, 458, 471.  
 Sums and products, Trig'metric, 387.
- Surface, Plotting a, 402, 405.  
 Surface area, 88, 169, 400.  
 Suspension cable, 45, 67, 130, 295 *ff.*  
 Symbols, List of, 508.  
 Synthetic substitution, or division, 40, 330, 487.
- Tables, 161, 500-507.  
 Tangent line, 15, 65-68, 92, 107, 275.  
 Tangent (of an angle), 160-164, 218-222, 351, 356, 368, 373, 386.  
 Tanks, 5, 45, 101, 187, 233, 394.  
 Taylor series, 428 *ff.*  
 Telescope, Reflecting, 295, 297 *ff.*  
 Time rates, 112 *ff.*  
 Translators of a curve, 314, 335.  
 Triangles, 116, 156-188, 216-222.  
 Trigonometric equations, 370.  
 Trigonometric functions, 160-188, 214-222, 350-391, 428-431, 433.  
 Trigonometry, 156. *See also* above
- Variables, 1-6, 70, 324, 413.  
 Varies as, 48.  
 Vectors, 158, 275, 463 *ff.*  
 Vectorial angle, 343.  
 Vibrations, 359, 378, 435.  
 Volume, 30, 64, 139, 397, 403, 412.
- Water pressure, 146, 175, 188.  
 Work, 27, 95, 138, 398.
- Zero, 35, 47, 92, 99, 354, 444.

### Some Further Applications to Various Fields, mainly in Exercises

- Aeronautics, 10, 27, 166, 325, 391.  
 Agriculture, 34, 87, 390, 436, 475.  
 Architecture, 41, 98, 166, 228, 306, 413.  
 Astronomy, 12, 28, 188, 306, 339, 350.  
 Biology, 5, 9, 31, 53, 339, 455, 480.  
 Business, 12, 55, 57, 224, 342, 459.  
 Chemistry, 53, 166, 191, 254, 264, 458.  
 Civil Eng'r'g, 63, 145, 150, 159, 269.  
 Economics, 4, 55, 87, 231, 269, 476, 481.  
 Heat, 16, 20, 53, 57, 191, 263, 408.  
 Hydraulics, 39, 121, 192, 201, 398.  
 Light and photography, 49, 102, 112, 165, 191, 264, 267, 270, 306, 478.  
 Machinery, 42, 56, 84, 254, 264, 270.
- Magnetism, 81, 140, 226, 325, 339.  
 Map-making, 29, 30, 273, 282, 344.  
 Medicine, 1, 11, 13, 18, 54, 270.  
 Metal work, 34, 91, 175, 186, 206, 305.  
 Navigation, 24, 118, 171, 390, 391.  
 Physiography, 121, 168, 171, 217, 362.  
 Psychology, 5, 166, 186, 459, 476.  
 Railways, 28, 31, 84, 87, 106, 165, 206.  
 Shipbuilding, 30, 87, 187, 273, 296 *ff.*  
 Sociology, 3, 13, 250 *ff.*, 270, 452, 479.  
 Sound, music, 302, 360, 381, 418, 435.  
 Sport, 118, 124, 274, 279, 344, 442 *ff.*  
 Telephony, etc., 3, 56, 250, 267, 390.  
 Warfare, 55, 118, 171, 180, 273, 325.



Handwritten text, possibly a title or date, including the number 1910.











AUG 21 1936



