

**Hand-book of electro-therapeutics / by William James Dugan ... with ninety-one illustrations.**

Dugan, William James, 1869-  
Philadelphia : F. A. Davis company, 1910.

<http://hdl.handle.net/2027/mdp.39015013215929>

# HathiTrust



[www.hathitrust.org](http://www.hathitrust.org)

**Public Domain, Google-digitized**

[http://www.hathitrust.org/access\\_use#pd-google](http://www.hathitrust.org/access_use#pd-google)

We have determined this work to be in the public domain, meaning that it is not subject to copyright. Users are free to copy, use, and redistribute the work in part or in whole. It is possible that current copyright holders, heirs or the estate of the authors of individual portions of the work, such as illustrations or photographs, assert copyrights over these portions. Depending on the nature of subsequent use that is made, additional rights may need to be obtained independently of anything we can address. The digital images and OCR of this work were produced by Google, Inc. (indicated by a watermark on each page in the PageTurner). Google requests that the images and OCR not be re-hosted, redistributed or used commercially. The images are provided for educational, scholarly, non-commercial purposes.

HAND-BOOK  
OF  
ELECTROTHERAPEUTICS  
—  
DUGAN

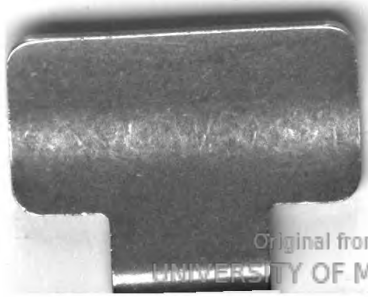









HAND-BOOK  
OF  
ELECTRO-THERAPEUTICS

BY

WILLIAM JAMES DUGAN, M.D.

LECTURER ON ELECTRO-THERAPEUTICS AT JEFFERSON MEDICAL COLLEGE,  
PHILADELPHIA; PHYSICIAN-IN-CHARGE OF THE ELECTRO-THERAPEUTIC  
DEPARTMENT AND ASSISTANT IN THE OUT-PATIENT NEUROLOGICAL  
DEPARTMENT OF JEFFERSON HOSPITAL; FELLOW OF THE  
AMERICAN ELECTRO-THERAPEUTIC ASSOCIATION.

WITH NINETY-ONE ILLUSTRATIONS



PHILADELPHIA  
F. A. DAVIS COMPANY, PUBLISHERS  
1910



---

**COPYRIGHT, 1910,  
BY  
THE F. A. DAVIS COMPANY.**

---

**[Registered at Stationers' Hall, London, Eng.]**

---



---

**Philadelphia, Pa., U. S. A. :  
Press of F. A. Davis Company,  
1914-1916 Cherry Street.**

---

TO  
DR. FRANCIS X. DERCUM  
PROFESSOR OF NEUROLOGY AT JEFFERSON MEDICAL COLLEGE,  
PHILADELPHIA

THIS VOLUME

IS

RESPECTFULLY INSCRIBED BY HIS PUPIL,

THE AUTHOR

“Physick can but mend our crazy state,  
Patch an old building, not a new create.”

*Dryden.*

“To sift truth from rubbish I do what I can.”

*Franklin.*

“There is a principle which is a bar against all information, which is proof against all argument, and which cannot fail to keep a man in everlasting ignorance; this principle is contempt prior to examination.”

*Herbert Spencer.*

(iv)

recd. by  
Gift  
Dr. C. D. Camp  
1-30-1922

## PREFACE.

---

It does not seem necessary to offer any apology for writing this small book on electro-therapeutics. While many volumes have been written on the subject, this monograph is intended to fill a space not occupied by any work now before the profession. Many of the books wholly ignore some of the modalities of electricity; some devote too much space to historical matter and to experiments made in the past; some enter into lengthy discussion of debatable questions and into the deduction of mathematical formulas; still others devote from 50 to 60 per cent. of their space to an exhaustive treatise on Röntgen rays.

This volume is intended for students and physicians who know little or nothing about electricity and electrical apparatus. The author has endeavored to make this work clear, modern, exact, and concise; to tell how to select electrical apparatus, how to use the apparatus after it has been purchased, *when* to use electricity in medicine, and, equally important, when *not* to use it. Most of the works are too voluminous for the average student of medicine, who has neither the time nor the inclination to read masses of theoretical details in order to get at the practical points necessary for an understanding of the proper application of medical electricity. The writer has attempted to tell, in a clear and concise manner, what the average physician should know of the different modalities and of their proper use. All moot questions are avoided and the book has been made as practical and up-to-date as is possible in a volume of its size.

Electro-therapeutics has passed from the domain of the charlatan to that of the regular practitioner. The writer has been especially careful not to claim for electricity absurd and impossible uses. Too frequently, enthusiastic advocates would have it usurp the functions of surgery (*e.g.*, in the treatment of cancer), or have it take the place of rational internal therapeutics. That its uses, however, are great and manifold is well

(v)

known, and that these uses are unfortunately not sufficiently appreciated is equally true.

Every student of medicine should at graduation have a clear idea of the subject, which is now considered of such importance that it has been added to the curriculum of all the larger medical colleges. The necessity for at least an elementary knowledge is shown by the misapplications constantly made by physicians. Thus electricity is abused when the physician uses the faradic current where the galvanic is indicated; when high frequency currents, which reduce blood-pressure, are employed in cases of hysteria with low blood-pressure; when static electricity, which raises blood-pressure, is administered in cases which already have a high blood-pressure; when the treatment is given for too long or too short a time; when the treatment is given but once a week when daily applications are indicated; and when an underlying cause, such as rheumatism, is not given medicinal treatment at the same time as the electrical.

As far as practicable, the detailed directions for the treatment of individual affections are given with precision both as regards the mode, the strength of current, the duration of each application and the frequency with which it should be repeated. These directions must, of course, be regarded as suited to the average case and conditions met with and must not be regarded as absolutely fixed.

For a consideration of Röntgen-ray therapy, the reader is referred to special works on the subject.

WILLIAM J. DUGAN.

Flanders Building, Philadelphia.

May, 1910.

# CONTENTS.

	PAGE
INTRODUCTION .....	1
CHAPTER I.	
ELECTRICITY .....	4
CHAPTER II.	
GALVANISM .....	16
CHAPTER III.	
STATIC ELECTRICITY .....	42
CHAPTER IV.	
FARADIC AND MAGNETIC ELECTRICITY .....	62
CHAPTER V.	
REACTION OF DEGENERATION .....	78
CHAPTER VI.	
ELECTROLYSIS .....	91
CHAPTER VII.	
CATAPHORESIS .....	97
CHAPTER VIII.	
ELECTRICITY IN SURGERY .....	104
CHAPTER IX.	
SINUSOIDAL CURRENT .....	111
CHAPTER X.	
HIGH FREQUENCY CURRENT .....	119
CHAPTER XI.	
THERMO-ELECTRICITY .....	144
CHAPTER XII.	
HYDRO-ELECTRIC BATHS .....	145
CHAPTER XIII.	
MAGNETISM .....	147

(vii)

	PAGE
CHAPTER XIV.	
SPECIAL THERAPEUTICS .....	158
CHAPTER XV.	
VIBRATORY MASSAGE .....	177
CHAPTER XVI.	
LIGHT AND HEAT THERAPY .....	181
-----	
APPENDIX .....	191
SUMMARY OF ELECTRICAL TREATMENT .....	211
GLOSSARY .....	215

## LIST OF ILLUSTRATIONS.

FIG.	PAGE
1.—Diagram of direction of current within a cell .....	20
2.—Cells in series. Unlike elements are connected in series .....	23
3.—Cells in multiple or parallel. Like elements are connected here .....	24
4.—No. 5 Victor portable battery .....	25
5.—Removable tray. (Victor.) .....	26
6.—Floor cabinet. (Victor.) .....	27
7.—Wall cabinet. (Victor.) .....	28
8.—Transformer, alternating to direct current. (Victor.) .....	29
9.—Diagram of three-wire system .....	30
10.—Milliampèremeter. (Victor.) .....	31
11.—Twenty-five point rheostat. (Victor.) .....	32
12.—Multiplex. (Victor.) .....	33
13.—Diagram of rheostat. (Victor.) .....	34
14.—Nickel-plated metal handle .....	34
15.—A "by-pass" .....	35
16.—Victor universal handle, with interrupter .....	35
17.—Hard rubber needle holder, with interrupter .....	35
18.—Wheel electrode, with interrupter .....	36
19.—Hard rubber needle holder .....	36
20.—Hemorrhoidal needle holder .....	36
21.—Needle holder, with magnifying glass .....	37
22.—Depilatory forceps .....	37
23.—Laryngeal electrode, nickel-plated, insulated .....	37
24.—Universal handle, with sponge-covered disc .....	37
25.—Ear electrode .....	37
26.—Sponge-covered electrode .....	37
27.—Newman's urethral electrodes .....	38
28.—Needle disc, for removal of nevi .....	38
29.—Double copper intra-uterine electrode .....	38
30.—Genito-urinary electrode case .....	38
31.—Gold-plated needles for electrolysis .....	39
32.—Uterine electrode, insulated with hard rubber .....	39
33.—Double ear electrode, insulated .....	41
33 <sup>a</sup> .—Universal electrode, flexible metal .....	41
34.—Double eye sponge electrode .....	41
35.—Eye cup electrode .....	41
36.—Victor cautery electrodes .....	42
37.—Waite and Bartlett's static machine .....	45
38.—Baker Electric Co.'s static machine .....	46
39.—Leyden jar. (Waite and Bartlett.) .....	48
40.—A Leyden jar .....	49
41.—Wave-current. (Morton.) .....	54
42.—The wave-current intensified. (Morton.) .....	55
43.—Static induced current. (Morton.) .....	58



FIG.	PAGE
44.—The pencil discharge or new spray .....	61
45.—Victor bi-polar electrode .....	68
46.—Victor bi-polar intra-uterine electrode .....	69
47.—Victor bi-polar massage electrode .....	69
48.—Victor No. 2 portable faradic .....	70
49.—Victor high-tension plate .....	71
50.—Victor No. 3 combined outfit (portable) .....	72
51.—Diagram of the motor points of the face. (Ranney.) .....	79
52.—Diagram of motor points .....	81
53.—Diagram of motor points .....	83
54.—Victor head lamp .....	105
55.—Victor bone engine .....	106
56.—Victor giant eye magnet .....	107
57.—Victor little giant eye magnet .....	108
58.—Victor ear massage outfit .....	109
59.—Drawing of sinusoidal .....	111
60.—Victor No. 9 transformer .....	117
61.—Drawing of Morton's static induced current of 1881 .....	119
62.—Drawing of Cavallo apparatus of 1780 .....	120
63.—Drawing of d'Arsonval apparatus .....	121
64.—Drawing of Tesla apparatus .....	122
65.—Drawing of static current through a solenoid .....	123
66.—Campbell X-ray tube .....	124
67.—Campbell radiograph of elbow. ....	Facing page 126
68.—Campbell radiograph of hand. ....	Facing page 126
69.—Campbell radiograph of heel. ....	Facing page 126
70.—Campbell radiograph of wrist. ....	Facing page 126
71.—Campbell model "D" coil, cabinet and X-ray .....	126
72.—Campbell d'Arsonval attachment .....	127
73.—Campbell coil and cabinet .....	128
74.—Campbell model "E" X-ray and coil .....	129
75.—Campbell coil, ready for carrying .....	130
76.—Campbell electrodes for high frequency .....	131
77.—Campbell "Auto-pad" .....	132
78.—Diagram showing magnetic lines of force .....	148
79.—Bachelet alternating generators .....	150
80.—Bachelet direct current and transformer .....	151
81.—Bachelet dry-cell generators .....	153
82.—Generators showing the working of the co-acting magnetic lines of force .....	155
83.—Bachelet generators in use in sick room .....	157
84.—Victor No. 1 massage outfit .....	176
85.—Victor chair and vibrator .....	178
86.—Victor portable vibrator .....	179
87.—Victor vibrator in carrying case .....	180
88.—Modern Medicine Co.'s lamp .....	184
89.—Modern Medicine Co.'s lamp (second view) .....	185
90.—Incandescent lamp .....	187
91.—Diagram of spectrum .....	189

# MANUAL OF ELECTRO-THERAPEUTICS

---

## INTRODUCTION.

ELECTRICITY is the name given to that which directly causes all electrical phenomena. The word "electricity" is derived from *ἤλεκτρον*, a Greek word meaning amber. Thales discovered that this strange transparent substance possessed, when rubbed, the power of attracting light substances. Many centuries afterwards Gilbert astonished England with the phenomena of electricity. At this time electricity was supposed to have a soul. Unfortunately Gilbert did not make medical application of his knowledge. In the middle of the eighteenth century Stephen Gray made the first real advances in the principles of electricity. Soon after this the Leyden jar was invented. At about this time our own Franklin, as every schoolboy knows, attracted the lightning from the clouds by means of his kite. Like all great discoveries, this, at first, was not appreciated in its transcendent importance, but very soon Franklin was signally honored in many foreign countries. Professor Richman, of St. Petersburg, known as a martyr of this science lost his life while experimenting in his laboratory. He had erected an iron rod to attract the lightning from the clouds as Franklin had done, and approaching too closely to the rod received the electrical discharge and was killed.

Then came the discovery of Galvani who, although noticing the twitching of the frogs' legs that had been hung on copper hooks which in turn were attached to an iron balcony, never ascertained the real cause of the twitching.

We should also speak of voltaic electricity, or of voltaism, for it was Volta who, a few years afterwards, discovered what

is now known as galvanism. He found that when two dissimilar metals were brought into contact, there was established an electrical current. He introduced his well-known *crown of cups* (*couronne de tasses*) using zinc and copper. We still use Volta's method, excepting that we use carbon in place of copper. Every schoolboy knows how a simple galvanic or voltaic cell may be made by placing a silver quarter under the tongue and a copper cent over the tongue. When the edges of the coins are brought together, the boy gets his first taste and touch of galvanism or voltaic electricity.

Dr. Ure, of Glasgow, while experimenting on the bodies of executed criminals produced such violent contraction of the diaphragm as to suggest the practical utilization of electricity for resuscitating persons who were unconscious from drowning. Electricity was first used as a therapeutic agent about the year 1748. Franklin, ten years later, employed the current for medical treatment in paralysis. Electricity was used in a London Hospital in the year 1767. About 1760 the Rev. John Wesley, the famous divine, published a treatise entitled "Electricity Made Plain and Useful."

In 1807 Sir Humphrey Davy, by means of a powerful voltaic battery, succeeded in decomposing moist potash and obtained metallic potassium at the negative electrode.

The discovery of magneto-electricity in 1831, by Faraday, was the milestone that marked another important stage in the progress of electrical science. The modern dynamo, evolved from Faraday's discovery, furnishes an electric power which costs but little more than steam.

The advances in the application of electricity have been marvelous but as physicians we need concern ourselves only with the advances in electro-therapeutics. Until the past few years a physician who used electrical treatment for disease was in danger of being classed with quacks and charlatans. We have no one but ourselves to blame for an attitude of mind arising from ignorance and superstition.

Fortunately the medical profession has awakened to the fact that intelligent practitioners alone should use electricity medicinally. They now realize that the requisites are an inti-

mate acquaintance with the fundamental principles of electricity and a good knowledge of medicine together with an accurate knowledge of the anatomy of the human body. Indeed every physician, graduating in this enlightened age, should know the general principles of the science so that he may be able to instruct his patient intelligently as to when electricity is needed and in what form it is required. It is not to be expected that every physician will equip his office with expensive electrical apparatus; but the patient has a moral right to expect that his family physician shall be able to say *when* electricity is needed. The great trouble in the past has been that the average physician knew absolutely nothing about electricity and so could not advise his patient in an intelligent manner. The result was only too lamentable, for the unfortunate patient often drifted into the hands of some charlatan who gave electricity—whether indicated or not—as long as the fees were forthcoming.

## CHAPTER I.

### ELECTRICITY.

---

ELECTRICITY is *not life*—despite the large advertisements of the charlatans who advertise electric belts and other contrivances. Electricity is a form of energy, just as heat is. There is but one *kind* of electricity. By means of various mechanical and electrical devices it is possible to cause electricity to manifest itself in various ways, but the difference is one of *degree*, not of *kind*.

There are three forms of electricity:—

1. Static—Franklinic or frictional.
2. Galvanic—continuous or direct.
3. Faradic—interrupted or indirect.

*Static* electricity is electricity in a state of tension and is produced by static or frictional machines.

*Galvanic* electricity is the current obtained from a galvanic cell; it is a non-alternating current and is called the direct current; this current may also be obtained from the street current (Edison current-mains).

*Faradic* electricity is the current generated in a coil of wire by induction; it is the induced, interrupted, or extra current.

All of the other varieties such as the sinusoidal, the high frequency, and the d'Arsonval currents are but modifications of the above forms.

A conception of the different forms of electricity may be had by visualizing the manner in which water may be sent out in a wide stream, or in a small stream from the nozzle of a hose, or under the aspect of escaping steam from the valves of a boiler. However dispersed the agent is still one and the same, namely water. Galvanic electricity may be compared to the water in a wide river; faradic, to the water from a nozzle; and the static, to the escaping steam.

(4)

A galvanic current is a simple direct, continuous and constant current.

Faradic and static currents are made up of isolated, alternating waves of electricity. The galvanic current has large volume but moderate pressure. The faradic current has a very small volume but great pressure in the isolated waves. The static current has exceedingly small volume but immense pressure.

The galvanic current should properly be named voltaic, after Volta. The only reason for naming the current after Galvani seems to be the fact that Galvani was a physician, being Professor of Anatomy at Bologna, while Volta was not.

Each of these forms is capable of being further modified. For instance, by means of a static machine, of which there are several forms, it is possible to generate and discharge numerous small quantities of static electricity in rapid succession so that it simulates, to a certain extent, a continuous flow. We can vary the pressure of the constant current at will and, by means of interrupters, render it intermittent, or pulsating, and as rapid or slow as we please. The induced—or faradic—current can be modified in many ways, as will be explained later.

Electrical science is founded on the effects produced by the action of certain forces on matter, and all knowledge of the science is deduced from these effects. Electricity exists everywhere, but it is so perfectly balanced that we are made aware of its presence only when this natural balance is disturbed. We are conscious of the presence of electricity only when an effort is made to regain the state of equilibrium after such disturbance.

We may study electricity as current electricity and static electricity. Static electricity is produced by friction and by the contact of dissimilar substances. Current electricity is that which flows through conducting bodies. The difference between static electricity and current electricity is demonstrated in the fact that static electricity is small in quantity but is of high potential, while current electricity is large in quantity but is of low potential. Current electricity is obtained by chemical action and by dynamos.

### CONDUCTION.

All substances do not equally conduct electricity so we divide substances into conductors—those substances which offer little resistance to the flow of electricity—and non-conductors—which offer a marked resistance to the flow of electricity. As is well known, every substance offers more or less resistance to the passage of electricity, while all substances conduct electricity to a more or less degree. Non-conductors are often termed insulators.

Resistance is a term used to express the property—which some substances possess to a marked degree—of resisting the flow of electricity. The opposite of resistance is termed conductivity. Shellac, for instance, is known to offer great resistance to the passage of electricity, while copper wire is known to possess great conductivity. The difference in resistance between these two substances is very great. Shellac, gutta percha, amber, resin, leather, oils and dry wood may be mentioned as good non-conductors or insulators. Silver, copper, gold, aluminum and platinum are good conductors.

*Table of Resistance.*—If the resistance of silver be placed at 1.00, we may arrange the following table of resistance:—

Silver .....	1.000
Copper .....	1.065
Gold .....	1.370
Aluminum .....	1.920
Zinc .....	3.750
Platinum .....	6.000
Iron .....	6.450
Lead .....	13.000
Mercury .....	62.740
Bismuth .....	87.250

### ELECTRODYNAMICS.

Electrodynamics is a term meaning the study of current electricity. Potential in electricity is analogous to *temperature* in heat, *pressure* in gases and *head* in liquids. In water the flow

is always, if possible, from a higher to a lower level, thus causing a common level, so in electricity the flow is always from the higher to the lower potential. It has been conceded by electricians that the positive state of electricity is at a higher potential than is the negative. From this it may be seen that the passage of electricity is from positive to negative. When water has reached its common level the flow stops, so in electricity the flow stops as soon as the difference of potential has been overcome.

### GALVANIC OR VOLTAIC ELECTRICITY.

This form of electricity is obtained from a cell which consists of a jar containing saline or acidulated water and two elements as described below. Both Galvani and Volta invented such cells.

The liquid is called the electrolyte. This term will be used later in a different sense as will be described under *electrolysis*. Into the liquid—contained in the jar—there are placed two dissimilar substances known as plates. One plate is the metal zinc and the other is carbon, a metalloid. (See illustration of galvanic cell, Fig. 1.)

If two or more simple cells are joined together, there will be formed a galvanic, or voltaic, battery. Metallic terminals are attached to the plates—zinc and carbon—and are used to connect the simple cells to form a battery or to convey the current to some outside source; these terminals have received the name of *poles* or *electrodes*. When the metal zinc is placed alone in the acidulated water—water and sulphuric acid—the zinc is attacked and sulphate of zinc is formed. It will be noticed that bubbles of hydrogen will come from the zinc and that the temperature of the liquid will rise. If we now place a plate of carbon in the electrolyte containing the zinc, and join the ends of the metallic terminals it will be found that chemical action takes place and that an electric current is generated. If the ends of the metallic terminals—or electrodes—are separated, the current ceases. We should remember that in a galvanic cell



the electrolyte attacks the positive plate. The following table will show how a galvanic cell may be formed:—

- |              |              |
|--------------|--------------|
| 1. Zinc +,   | 4. Silver,   |
| 2. Lead,     | 5. Gold,     |
| 3. Copper,   | 6. Platinum, |
| 7. Carbon —. |              |

In the above table any two of the substances may be used to form a galvanic couple. The farther apart the elements are on this list, the greater will be the potential. For this reason, galvanic cells are now usually made up with zinc and carbon elements. If in a copper-zinc cell we substitute carbon for the copper the difference will be greater, as carbon is more negative to zinc than is copper—that is, carbon and zinc are farther apart in the scale of electro-motive force in metals.

#### ELECTRO-MOTIVE FORCE.

With a static machine it is possible to produce sparks twelve inches in length. This proves that static electricity has a very high potential force. With a galvanic battery it is possible to produce a spark of but one-fiftieth of an inch in length, thus proving that current electricity has a very low potential force. Now, if one wishes to measure the actual quantity of electricity—as shown by the decomposition of water—it will be found that a static machine will not decompose as much water as will a very small galvanic cell. This means that static electricity has small quantity, while current electricity may have great quantity. The term electro-motive force—often abbreviated to E. M. F., or even E.—means that force which moves electricity from one place to another. This term should not be confounded with *electric force*, which is the force by means of which electricity is utilized in moving objects from one place to another. The terms *electro-motive force*, *voltage*, *pressure* and *difference of potential* all mean the same thing—the *driving force* of the electric current.

In order to bring about a passage of electricity it is necessary to have established a *circuit*. A circuit is the path over

which the electric current flows from one point, through a conductor, back again to the starting place. If conductors are disconnected so the current cannot flow, the circuit is said to be opened or broken. If the current is allowed to flow, the circuit is said to be closed or completed. There are two circuits, termed internal and external. The internal circuit—consisting of the electrolyte and the submerged parts of the elements—is that part of the circuit *within* the source of the current. The external circuit—consisting of the conducting wires and the portion of the elements not submerged—is that part of the circuit *without* the electric source. Sometimes one hears of a divided circuit. This means that the circuit is divided into branches so that each branch transmits part of the electric current. In such a case each branch—if taken separately—would be termed a *shunt*. The conductors forming these branches are said to be connected in parallel or multiple arc. If the positive electrodes of all of the cells are joined to form one main positive electrode and the negative electrodes of all of the cells are connected to form one main negative electrode, the cells are said to be connected in parallel or multiple arc. If the positive electrode of one cell is connected to the negative electrode of the next cell, so that the current is made to pass through each cell, the cells are said to be connected in *series*.

We measure electro-motive force by the volt (so-named after Volta). The volt is the unit of E. M. F. and is the amount of E. M. F. which will force a quantity of electricity, known as coulomb through a resistance of one *ohm*. One volt corresponds very nearly to the amount of E. M. F. developed in a Daniell cell, described later. All copper-zinc cells, and also the chloride of silver cells, have an electro-motive force of about one volt. The electro-motive force of a Leclanché cell, which is a zinc-*carbon* cell, is practically a volt and a half, or 1.50 volts. The electro-motive force of a Daniell cell, which is a zinc-*copper* cell, is 1.079 volts. This will at once show the greater electro-motive force of the zinc-*carbon* cell.

There are three factors in every electric circuit which must be considered:—

1. The force tending to move the electricity, termed E. M. F., has been already described.

2. The rate of flow of the electricity—that is, the current, written C.

3. The resistance which the force must overcome to produce the flow of electricity, written R.

In the case of water flowing through pipes, we have the pressure, or head of water, corresponding to the current in electricity; and the friction in the water pipes, corresponding to the resistance offered to the passage of electricity.

The strength of any electric current, or the rate of flow of electricity, is a ratio between the electro-motive force and the resistance of the conductor through which the current flows. Dr. G. S. Ohm, of Germany, discovered this ratio in electricity, so the ratio is called *Ohm's law*. Ohm's law means that the strength of any electric current in any circuit equals the quotient obtained by dividing the electro-motive force by the

$$\text{resistance, i.e., C. (current)} = \frac{\text{E. M. F.}}{\text{R. (resistance)}}.$$

In electricity we employ two systems of units. These are: first, the *fundamental*; and, second, the *practical* units. The electro-therapeutist will have to do with the practical units only. The practical units are the *ampère*, the *volt*, the *ohm*, the *coulomb* and the *watt*.

*The Ampère.*—The ampère is the practical unit of electric current and is analogous to the rate of flow of liquids in gallons per minute. When the quantity of electricity passing through a conductor is one *coulomb* per second, the strength of the current is one *ampère*. When one practical unit quantity of electricity is flowing every second continuously, the strength of the current or the rate of flow is one ampère. It makes no difference in the number of ampères whether the current flows for a fraction of a second, or for a longer period of time, if the quantity of electricity that would flow in one second remains the same in each case. We say the strength of current in *ampères* is the same in either case.

We determine the strength of an electric current by the effect produced, the actual quantity of electricity which has passed between two points being determined by the product of the current strength multiplied by the time.

*The Coulomb.*—The coulomb is the practical unit of quantity of an electric current. The coulomb is the quantity of electricity passing in one second through a circuit when the current strength is one ampère. One coulomb flowing for one second will deliver one ampère.

In measuring the strength of current we use (a) the action of electricity before a magnetic needle and (b) its chemical action. When a current of electricity is passed through water, the electricity decomposes the water into the two elements, hydrogen and oxygen. Of course the quantity of water decomposed will depend entirely on the current strength and also on the time the electricity is allowed to flow. If we but adopt a definite quantity of water and a certain time we may easily obtain a unit of strength of current. It has been agreed that the strength of current which will decompose .00009324 gram or .0014388 grain of water in one second shall be *one ampère*.

#### THE UNIT OF RESISTANCE.

The strength of an electric current depends upon the electro-motive force and the resistance of the conductor.

The unit of resistance is called the *ohm*. If we have a cell of an electro-motive force of one volt and this cell produce a current of one ampère, the internal resistance will be one *ohm*. Internal resistance is symbolized by “r;” external resistance by “R.” About 100 feet of ordinary bell wire has a resistance of one ohm. If we desire to increase the resistance to two ohms, we may either use 200 feet of the same sized wire, or use 100 feet of wire with a diameter one-half that of the original 100 feet of wire. In other words, a wire of a certain length and a certain diameter will have twice the resistance of a wire one-half that length but with the *same* diameter, or twice the resistance of a wire the *same length* but *twice* the diameter of the first wire. Silver wire presents less resistance than does copper. A

wire of iron would present about seven times the amount of resistance found in a copper wire of the same length and diameter.

There is an internal resistance within the cell which must be reckoned with, varying as it does from about  $\frac{1}{4}$  of an ohm in an acid cell to two ohms in a Leclanché cell. The internal resistance of a cell may be reduced by decreasing the distance between the two elements and by increasing their active surfaces, by using larger plates.

### OHM'S LAW.

All that the physician need remember about this law is that the law is expressed in algebraic form, thus:—

$$\text{Current strength} = \frac{\text{Electro-motive force}}{\text{Resistance}}, \text{ or } C = \frac{\text{E. M. F.}}{\text{R.}}$$

It is very easy to find one of these values if the other two are given. If we are given the E. M. F. and the R. we find the C.—expressed in ampères—by dividing the E. M. F. by the R.

We should always remember to get the total resistance—*i.e.*, both *internal* and *external*.

We never use the ampère in electro-therapeutics, as one ampère would be much too strong. One ampère is divided into one thousand parts, each being called a milliampère; and we may state that we are using so many milliampères. Very often the word is abbreviated, thus: 18 m.a. = 18 milliampères. The *coulomb* is likewise divided into millicoulombs.

The volt is the unit of electro-motive force.

The ohm is the unit of resistance.

The ampère is the unit of current *strength*.

The milliampère is the unit of *current volume used*.

The millicoulomb is the unit of *quantity consumed*. It is a term seldom seen, however, in medical literature.

The watt is the unit of electric power. It is the power of a current in which the electro-motive force equals one volt, and the current strength equals one ampère. The watt is obtained by multiplying the number of volts by the number of ampères.

One watt = one volt  $\times$  one ampère =  $\frac{1}{746}$  horse-power.  
 $W. = E. M. F. \times C.$

A kilowatt = 1000 watts = 1 K. W.

We speak of a watt hour, which means a current of one ampère with an electro-motive force of one volt, flowing for one hour. A current of 10 ampères at 100 volts, flowing one hour, would equal 1000 watt hours, *i.e.*, 10 ampères  $\times$  100 volts  $\times$  one hour = 1000 watt hours. 1000 watt hours = the "Board of Trade" unit. This unit is not used in electro-therapeutics, but as the street current is often used at present by physicians it behooves us to know the meaning of the term "Board of Trade" unit.

The farad is the unit of capacity and represents the capacity which is charged to one volt when a current of one ampère flows for one second.

In medical electricity we have to do with very high resistance but very small currents. The resistance in the human body varies from 3000 to 6000 ohms (with a current of 15 volts); but, in some diseases, the resistance may be lowered greatly. In exophthalmic goitre it may be as low as 500 ohms with a 15-volt current.

When we remember that metals are good conductors of electricity we may readily see why the solution of the salts of metals will decrease resistance. One part of common salt dissolved in 100 parts of water will conduct 100 times better than plain water. So we decrease the resistance by applying to the human body electrodes well wetted with salt water.

#### EFFECTS OF THE ELECTRIC CURRENT.

The electric current may produce various effects such as:—

1. Light.
2. Heat.
3. Mechanical effects, as lightning discharge.
4. Physiological effects.
5. Electrolytic effects.
6. Magnetic effects.

**CURRENT ELECTRICITY.**

Current electricity flows through conductors.

The quantity may be large but the tension or potential may be small.

Current electricity is generated as follows:—

1. By chemical action.
2. By heat.
3. By disturbances of the magnetic field as in dynamos.

In frictional electricity the sparks may follow each other so closely that, to the naked eye, there appears to be a continuous flow. This is not so in reality for there is always a gap between the sparks, although the gap may not be appreciable.

In a galvanic cell we have a constant flow. The current is called a constant or galvanic current.

There are two kinds of galvanic cells:—

1. The single fluid cells, or those with but one fluid.
2. The double fluid cells, or those with two exciting fluids.

In every galvanic cell we must have:—

A galvanic pair or couple and one or two exciting fluids.

The galvanic couple—the two substances—constitute the elements. The fluid is termed the electrolyte.

For medical purposes we may produce electricity in the following ways:—

1. By the action of mechanical energy—by a frictional machine, an electro-static induction machine, or a dynamo-electric machine.

2. By the action of radiant heat—through the thermo-electric cell.

3. By chemical action—by a galvanic or primary cell, or by a charged storage or secondary cell.

**SOURCES OF ELECTRICAL ENERGY.**

We derive

Static electricity, from frictional machines.

Galvanic electricity, from galvanic or primary cells.

Induced, or faradic, electricity, from induction machines.

Thermo-electricity, from a thermo-electric machine.

We may make use of

High frequency currents.

Sinusoidal electricity.

D'Arsonval electricity.

Combined or galvano-faradic electricity.

The magnetic wave.

Houston and Kennelly arrange the different forms of electric current as follows:

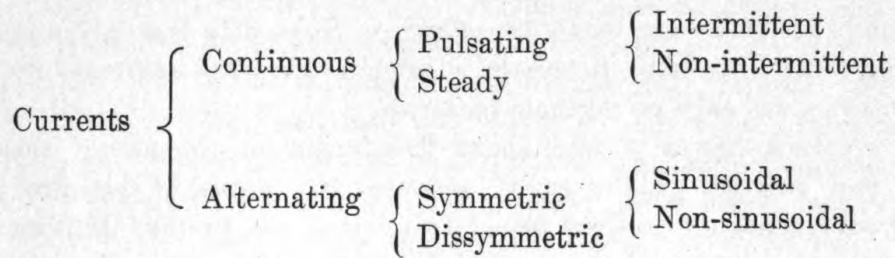



## CHAPTER II.

### GALVANISM.

---

IN medicine we derive the galvanic current from batteries made up of cells, or from the street current (Edison current-mains). If we use batteries—which is frequently the only way for some physicians to obtain a galvanic current—we may use either stationary or portable batteries.

Much has been said about the danger in the use of the street current. However, if a proper apparatus be procured from a reliable firm there need be no fear of any trouble. It is an undoubted fact that the current from an Edison main is much smoother than a current from batteries; it is, in every way, to be preferred if accessible.

#### DIFFERENT KINDS OF CELLS.

**Double Fluid Cells.**—The *Bunsen cell* consists of a zinc-carbon couple, each element immersed respectively, the zinc in dilute sulphuric and the carbon in nitric acid. It has the same electro-motive force as the Grove cell, with higher internal resistance, but the current lasts longer.

The *Daniell cell* consists of a zinc-copper couple immersed, the zinc in dilute sulphuric acid and the copper in a sulphate of copper solution. In the Daniell cell there is little or no polarization. The electro-motive force is small with a large internal resistance.

The *Grove cell* consists of a zinc-platinum couple, sulphuric and nitric acid respectively. Poisonous, red and very objectionable fumes, a compound of nitrogen and oxygen, are given off from this cell. There is no polarization in this cell; the electro-motive force is large at the beginning, but rapidly decreases.

**Single Fluid Cells.**—The *Smee cell* is a zinc-platinum couple, consisting of a plate of zinc and a plate of platinized

silver, dipping into dilute sulphuric acid. It has a low electro-motive force.

The *zinc-carbon cell* consists of a *zinc-carbon* couple in a weak solution of sulphuric acid (10 per cent.  $\text{H}_2\text{SO}_4$ ). The electro-motive force is higher than that of the Smee cell.

**The Bichromate, or Chromic Acid Cells.**—Bichromate of potassium and chromic acid have been very largely used to get rid of the objectionable fumes from using nitric acid. A *zinc-carbon* couple in a solution of bichromate of potash, and sulphuric acid in water are in a bichromate cell.

The *Grenet cell* is largely used for medical purposes. It consists of a glass flask, into which extend from a hard rubber cover, two carbon plates and an adjustable zinc plate to which is attached a long brass rod. The carbon plates reach to the bottom of the flask, but the zinc plate may be lowered or raised at will, so that the cell may very easily be put in or out of action. The electrolyte is a solution of sulphuric acid and bichromate of potassium in water. It is called the electropon solution. There is small internal resistance with high electro-motive force in this cell.

The *Leclanché cell* consists of *zinc-carbon* couple in a solution of ammonium chloride (sal ammoniac) with manganese peroxide to prevent polarization. This cell is largely used by physicians. It is a very desirable cell, because it lasts a long time, requires very little attention, and is easily renewed.

The *Law telephone cell* is a modification of the Leclanché cell.

The *porous cell* is a jar of unglazed earthenware employed in double fluid voltaic cells, to keep the two liquids separate.

The *gravity cell* consists of a *zinc-copper* couple in a solution of zinc sulphate and a saturated solution of sulphate of copper.

The *selenium cell* is a cell consisting of a mass of selenium fused between two conducting wires or electrodes.

*The Silver Chloride Cell.*—This cell consists of a *zinc-silver* couple immersed in a dilute aqueous solution of sal ammoniac and sodium chloride. Blotting-paper—about 8 to 10 sheets—saturated with this exciting fluid, is placed between the zinc and the silver.

*The Dry Cell.*—This consists of a cell in which the liquid electrolyte is rubbed up so as to make a paste and is really not a dry cell at all, unless we look at it from the standpoint that this cell is drier than a Leclanché cell.

*The Voltaic Cell.*—The term voltaic cell is employed to denote any apparatus consisting of a jar, the liquid and the elements which produce an electric current.

TABLE OF THE DIFFERENT KINDS OF CELLS.

NAME OF CELL.	ELEMENTS.	EXCITING FLUID.	DEPOLARIZING FLUID.	E. M. F. IN VOLTS.	INTERNAL RESISTANCE IN OHMS.
Leclanché	Zinc + Carbon—	Sol. Ammonium Chloride	Manganese Dioxide	1.6	1.15
Smee	Zinc + Platinized Silver—	Dilute H <sub>2</sub> SO <sub>4</sub>	None.	0.48	0.5
Daniell	Zinc + Copper—	Zinc Sulphate solution	Copper Sulph. solution	1.080	2.5
Grove	Zinc + Platinum—	Dilute H <sub>2</sub> SO <sub>4</sub>	H N O <sub>3</sub>	1.95	0.1
Chromic Acid	Zinc + Carbon—	Dilute H <sub>2</sub> SO <sub>4</sub> and Chromic Acid mixed	None separate	2.2	0.09
Bunsen	Zinc + Carbon—	Dilute H <sub>2</sub> SO <sub>4</sub>	H N O <sub>3</sub>	1.95	0.18

### AMALGAMATION.

In all zinc-carbon cells, the zinc is chemically acted on by the acid of the electrolyte. The ordinary zinc of commerce often contains lead and iron. When the electrolyte attacks these particles of lead or iron, there is at once established a complete circuit and the zinc is attacked. This will not occur if we rub the zinc plate with mercury which, of course, forms a zinc amalgam.

The following solution forms a very efficient electrolyte:—

Sulphuric acid ..... 6 parts  
 Potassium bichromate ..... 6 parts  
 Mercury oxysulphate ..... 2 parts  
 (used for the amalgamation of the zinc)  
 Water ..... 100 parts

*Directions for Preparing the Solution.*—We add 2 parts of the sulphuric acid to 8 parts of water; while still hot we add 1 part of bichromate of potassium; when cold the solution is ready for use. To amalgamate the zinc in this case, we first cleanse the zincs by dipping them into dilute sulphuric acid and then placing them in a vessel containing mercury; we should allow the excess of mercury to run off.

The electropon fluid may be used instead of the above solution.

### POLARIZATION.

When the plates of a cell are joined externally by a conductor, we see at once bubbles of hydrogen forming at the copper, or at the carbon plate. This is known as polarization. The effects of polarization are two in number as follows:

1. It reduces the conductivity of the cell by increasing the internal resistance.

2. It sets up an opposing electro-motive force by producing a current in the opposite direction.

Polarization may be prevented by both mechanical and chemical means thus: the plates may be shaken to loosen the bubbles; chemically, the method of employing bichromate of potassium has already been shown.

### SHORT-CIRCUITED CELL.

A cell is "short-circuited" when, as the word implies, the conductors completing the circuit are short, or have a smaller resistance than the cell was intended for.

The cells of a Leclanché battery are intended for a large *internal* resistance and to overcome a large *external* resistance but may be used up in a short time if the electrodes are left in contact.

### BATTERIES.

A number of cells properly joined constitute a battery.

In order to have a difference of potential in any cell, the chemical action on one plate must be greater than that upon the other. The plate that is more acted on by the acid is called the *positive* plate; the other is called the *negative* plate.

Electricity always flows from a higher to a lower potential; so the flow will always be from the *positive* to the *negative*. This is made clear by the following diagram:—

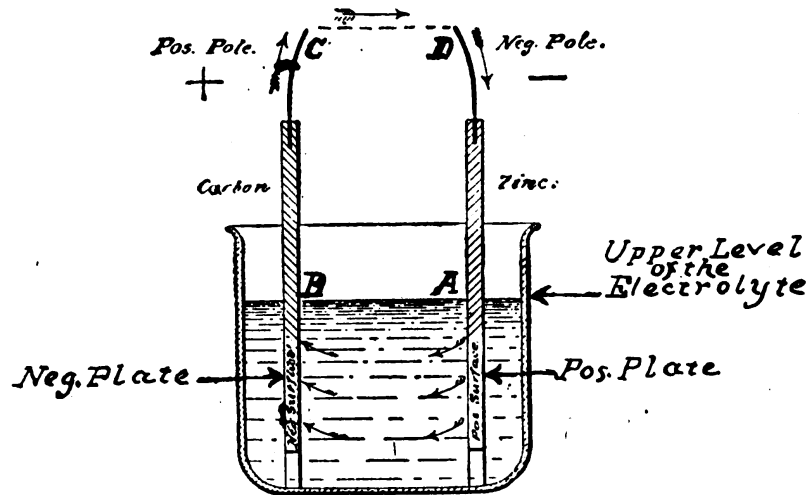

Fig. 1.—Diagram of direction of current within a cell.

*Explanation of the Diagram.*—The current flows from A to B through the electrolyte; this is where we find the *internal* resistance which is designated by “r.” From B to A outside of the electrolyte gives us the *external* resistance designated by “R.”

The plate marked zinc is the *positive plate*.

The plate marked carbon is the *negative plate*.

The pole marked C is the *positive* pole (not the negative).

The pole marked D is the *negative* pole.

We should remember that the electricity will flow from the zinc to the carbon, so that there must be more electricity at the top of the carbon, or negative plate, and this pole must necessarily be positive because it has more electricity than has the pole marked D. It may be somewhat confusing, at first, to learn that a positive pole is at the top of a negative plate. If the diagram be carefully studied no confusion or misunderstanding need arise.

**THE EFFECTS OF THE POLES ON THE TISSUES.**

Electrical currents produce on the tissues of the human body these effects, namely: physical, chemical and physiologic. The physical effects are mechanical, dynamic, thermic and magnetic; the chemical effects are those produced by polarization and by electrolysis; the physiologic effects are those exerted upon the muscles and nerves—such as the stimulation of the muscles and the nerves with the resultant contraction produced in the muscle. Electrotonus, the qualitative and quantitative reactions of muscles and nerves, the flashes of light, the roaring in the ears, and the metallic taste in the mouth, produced when the galvanic current is applied about the face, are also included under physiologic effects. The effects of the poles on the tissues may be summarized in the following table:—

POSITIVE POLE.	NEGATIVE POLE.
1. Oxygen collects here.	1. Hydrogen collects here.
2. Acid.	2. Alkaline.
3. Hemostatic.	3. Increases bleeding by dilating the blood-vessels.
4. Sedative.	4. Produces hypersensitiveness.
5. Hardens tissue.	5. Liquefies and disintegrates.
6. Is an acid caustic, so the resultant cicatrix is hard and unyielding.	6. Is an alkaline caustic, so the resultant cicatrix is soft and pliable.
7. Is a vaso-constrictor.	7. Is a vaso-dilator.

**TESTS FOR POLARITY.**

It is very important to know which pole is being used when we are applying electricity. If we connect our electrical apparatus at the socket of one electric light and find that a certain pole is the positive one, we may find that this pole may be the negative one if we make the attachment to another socket in the same room. It is very important to remember this, or otherwise we may be led into the error of thinking that all sockets in a building give the same polarity. This is owing to the careless wiring done by some electricians.

We must have some way of telling the positive from the negative. The following tests are recommended:—

1. Wet litmus paper, apply poles about one inch apart and use a current of 10 volts. A *red* color will make its appearance at the *positive* pole and a *blue* color at the *negative*.

2. Wet blotting paper with a saturated solution of iodide of potassium, proceed as above, and a *brownish* stain will appear at the *positive* pole, where the iodine is deposited.

3. Place the poles, *about one inch apart*, in a glass of water. Electrolysis will take place and bubbles will be seen at each pole, but the *greater number* of bubbles—of hydrogen—will be seen at the *negative* pole.

4. If a mixture of iodide of potassium and starch paste be used, a blue color will appear at the positive pole—iodide of starch. If iodide of potassium be dissolved in starch water, the discoloration at the *positive* pole will be *blue* instead of brown as might be expected, as the nascent iodine at *once* unites with the starch, forming iodide of starch which is of a blue color.

5. If we use a solution of phenolphthalein no change will make its appearance when the positive pole is in the solution, but a bright red color will appear when the negative is placed in the solution. This is utilized in making a *pole tester*.

6. Using a weak current we will get a weak *alkaline* taste if we apply the negative pole to the tongue, and a sharp acid taste if the positive pole be applied.

7. If we ascertain the positive pole and are using an ampèremeter, we will notice that the needle follows the positive pole; if the pole changer be used the needle is at once deflected to the opposite side. Hence, by watching the ampèremeter we can always determine the positive pole by observing the direction toward which the needle points.

We remember how, in chemistry, we amused ourselves by making a solution of phenolphthalein in water—a solution that looked like water—and then, by adding an alkaline solution, we produced a bright red color; then, by again adding an acid solution, we returned the red solution to its original white color. This fact is utilized in preparing what is known as a *pole tester* which consists of phenolphthalein, either in solution or mixed so as to form a paste; in either case the *negative* pole will produce a *red* color.

### FORMATION OF A BATTERY.

We have seen how a simple cell is formed, and it would seem that no trouble should be encountered in connecting two or more cells to form a battery. A great deal of the success of our work will depend on the arrangement of the cells.

The first question to be asked is whether we wish a *large voltage* and a *small ampèrage* or a *small voltage* and a *large ampèrage*.

How are we to determine this?

We know that we need a *large voltage* if we are to treat the human body, because the resistance to be overcome will be large—*i.e.*, from 3000 to 6000 ohms. The condition confronted may be compared to a case where a large engine is required to pump water through pipes which present the drawback of great friction. We get a *large voltage* by connecting the cells in *series*, *i.e.*, by joining the *unlike elements* together, the *zinc* of one cell to the *carbon* of the next. For electro-therapeutic use, all galvanic batteries are connected in *series*.

If we wish to heat a platinum wire for cautery work, we will have but a small resistance; so we produce a *large ampèrage* by connecting in *multiple* or *parallel*. This is done by joining the *like* elements, *i.e.*, the zinc of one cell to the zinc of the next.

It is very important that the electro-therapist understands thoroughly the difference between batteries connected in series and batteries connected in multiple or parallel.

A battery arranged in *series* is shown in the following diagram:—

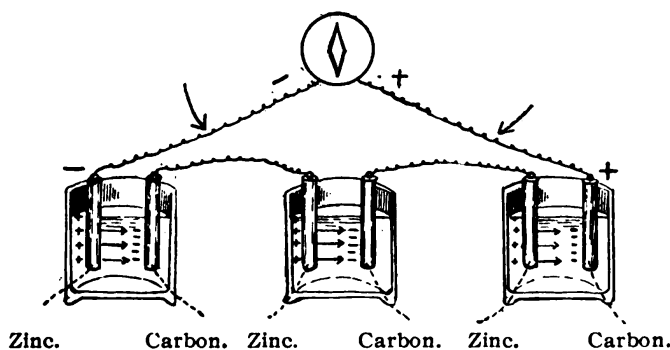

Fig. 2.—Cells in series. Unlike elements are connected in series.



If each cell in the above battery gives a pressure of one volt and one ampère in quantity, we will have *three volts* and but *one ampère*.

A *watt* = volts times ampères, hence 3 v. times 1 a. = 3 watts.

This diagram shows a battery connected in multiple or parallel.

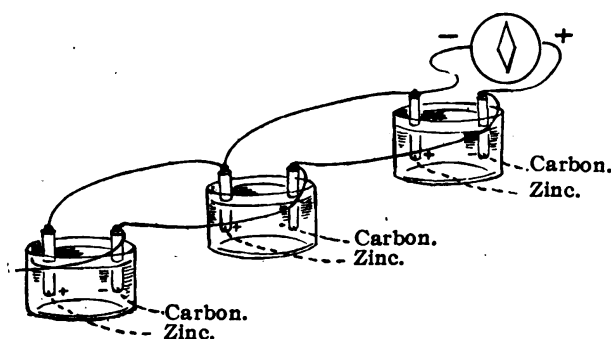

Fig. 3.—Cells in multiple or parallel. Like elements are connected here.

In this arrangement we will have *three ampères* and but *one volt*, or the same as we would have if the three cells formed only *one large cell*. Hence we have 3 a. x 1 v. = 3 watts, the same as above, so the number of *watts* will be the same whether the cells are connected in *series*, or in *multiple* or *parallel*, if in each case we use the same number of cells; the *amount* of work will be the same in either case, but the *kind* of work will be different.

Sometimes the "group" method is employed. The carbon of the first cell is joined to the carbon of the second; the zinc of the first is joined to the carbon of the fourth cell; the zinc of the second to the carbon of the third; the zinc of the third to the zinc of the fourth. By this method we have two of the cells in series and the remaining two in parallel and thus double the size of the cells while halving their number.

The best kind of cell for a *portable* battery is one which has elements of carbon and zinc in a solution of sulphuric acid with bichromate of potassium. It is well also to add a small amount of bisulphate of mercury to amalgamate the zinc. We

should remove the elements in this form of battery, when not in use, to prevent the consumption of material when the battery is not in active service. The wet cells in a *portable* battery would make it cumbersome, so usually some form of *dry* cell is used. About 40 cells should be in a *portable* battery. We should remember that cells will deteriorate even when not in use.

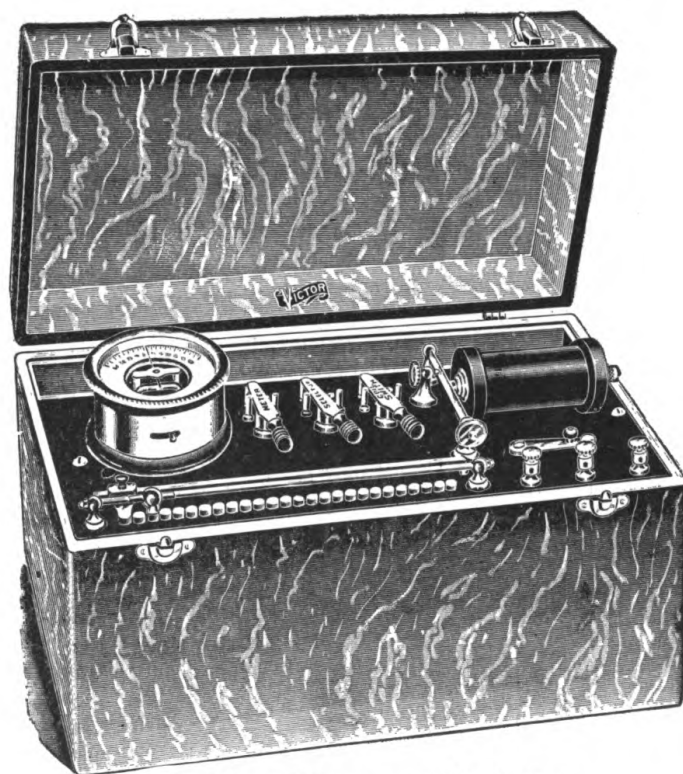

Fig. 4.—No. 5 Victor portable battery.

It is very important in applying electricity to use the milliampèremeter. If we are testing for reaction of degeneration and note that we use 18 cells to-day and, one week later, use 20 cells to produce the same contraction, we should not forget that the extra number required may be due to loss of power in each cell. If we say so many milliampères were used we cannot be in error. The scientific way of stating results is in milliampères.

For office use the best form of cell is the Leclanché, or

some modification of it. It is not necessary to remove the elements from this cell.

We will remember that polarization is due to a collection of hydrogen bubbles on the carbon elements; this then becomes the generating plate and a new current of electricity is started toward the zinc. There are several methods of preventing

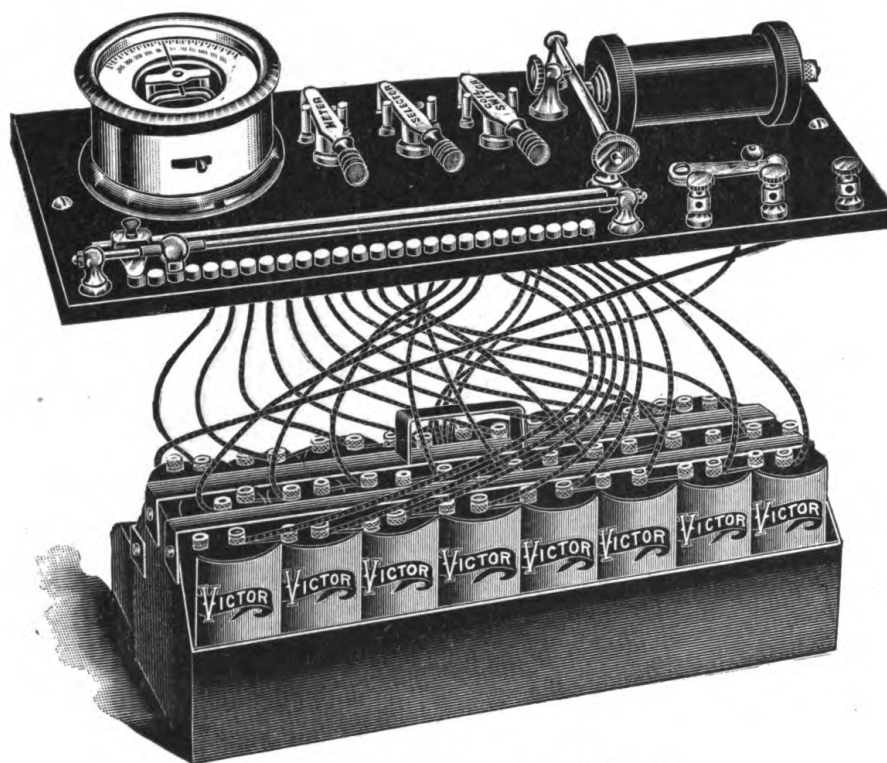

Fig. 5.—Removable tray. (Victor.)

polarization. The *larger* the carbon element, the longer it takes for polarization to occur. We use, therefore, as large a *carbon* element as possible.

In cities one is enabled to use the current from the street lighting circuit. This current may be either *direct* or *alternating*. The direct current may be used for therapeutic purposes. If we are supplied by an *alternating* current we must use a small *direct* current *generator*, which is operated by an *alternating* current *motor*.

In one section of Philadelphia a *direct* current is supplied, that is, in the district extending from Pine street on the south to Vine street on the north, between the rivers; the other sections of the city receive the *alternating* current.

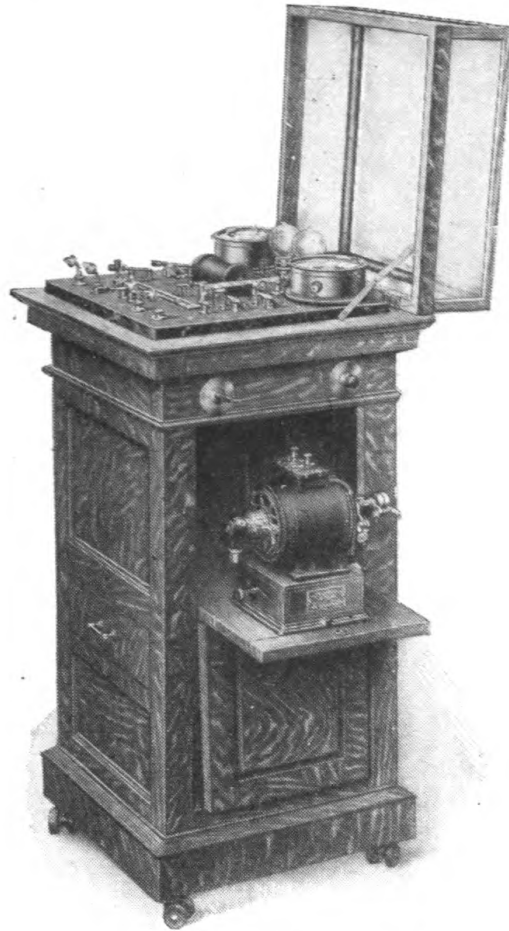

Fig. 6.—Floor cabinet. (Victor.)

A *rectifier* is an apparatus which changes the *alternating* current into a *direct* one.

Usually a current of 110 volts is furnished, although at Jefferson Hospital the current is one of 220 volts.

**THREE-WIRE SYSTEM.**

In large cities where electric wires for lighting are used the electro-therapeutist may well dispense with cells, which are

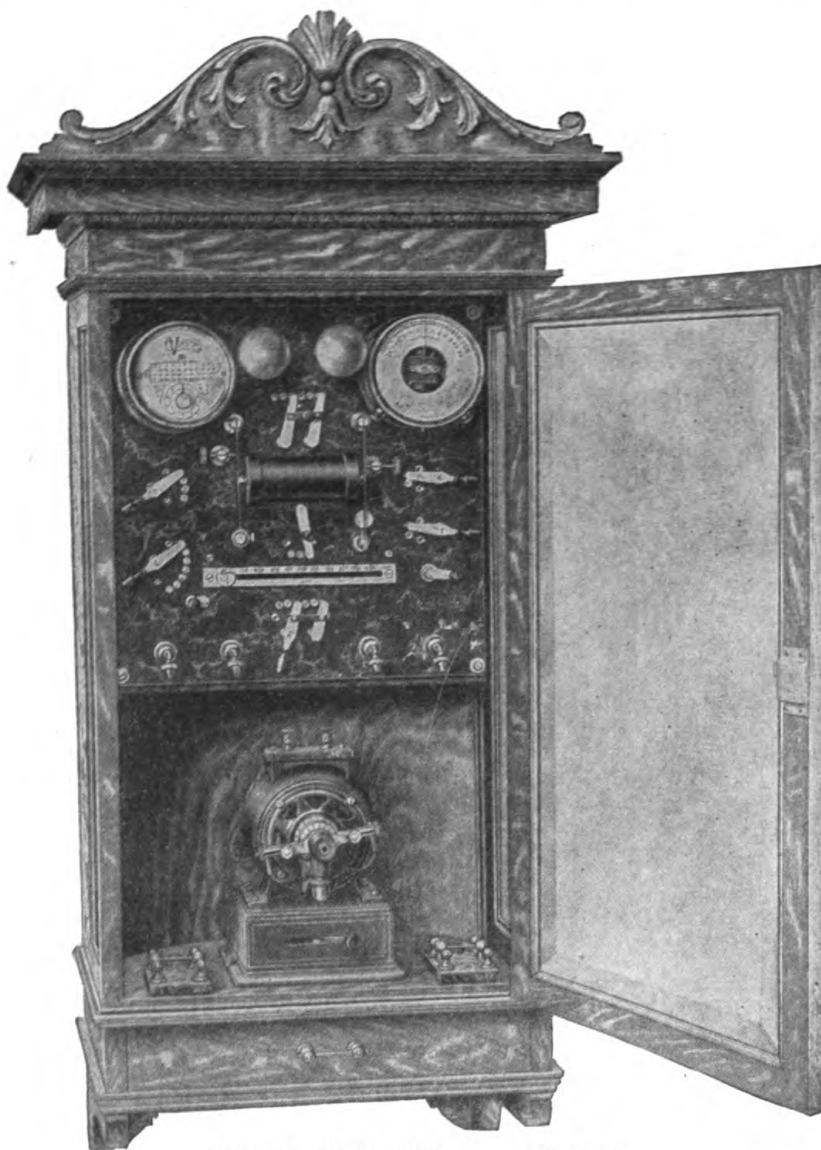

Fig. 7.—Wall cabinet. (Victor.)

troublesome at best. Some physicians seem to be afraid to use the street current because of the frequent accidents which occur on the streets of large cities. One should remember that, in the

accidents reported, the person usually falls on a *non-insulated* wire, and so receives a full charge of electricity.

As used in an office the current is always under such complete control, if one employ reliable apparatus, that an accident should never occur. The current should be the one supplied for lighting incandescent lamps. Two currents are used for this purpose, the *direct* and the *alternating*. The *direct* current is *constant* and is the one for physicians to use, as it very closely resembles the current obtained from a battery such as the

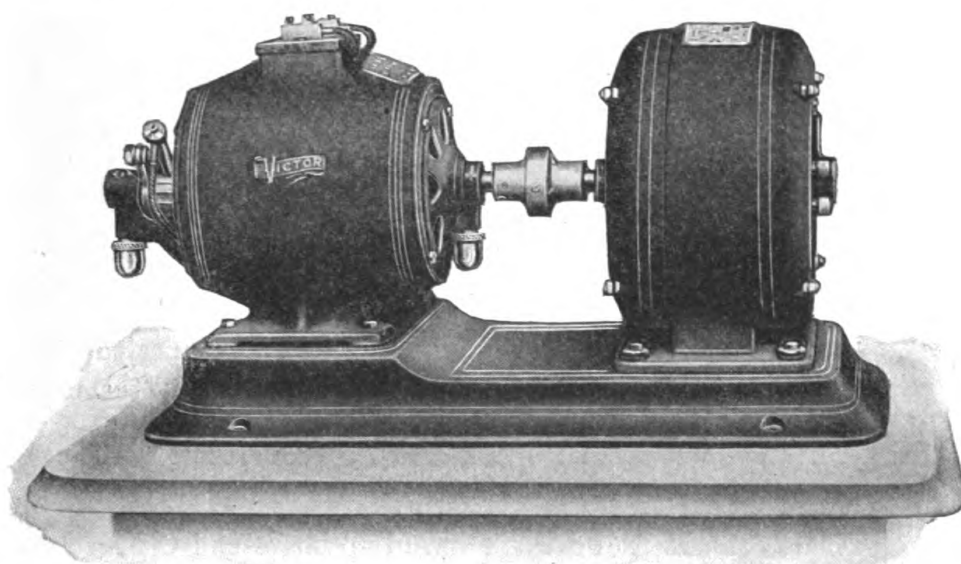

Fig. 8.—Transformer, alternating to direct current. (Victor.)

Leclanché. In using an *alternating* current, we must first, by means of a transformer, cut down the voltage and secondly, by means of a commutator, change the *alternating* current to a unidirectional one.

For transforming alternating to direct current.

A great many physicians suppose that the real danger in using the street current lies in the sudden increase of the current strength. This is not at all the fact. The real danger in any large city lies in the leakage currents in both *direct* and *alternating* currents and, in the case of the *alternating* current, of a breaking down of the insulation between the primary and

secondary transformers. If the *neutral* wire in a three-wire system should come in contact *underground* with gas or water pipes, there may be carried into a house a large amount of electricity by means of the faucets in wash-stands and bath-tubs, or *via* the gas jets.

The three-wire system may be briefly explained thus:—

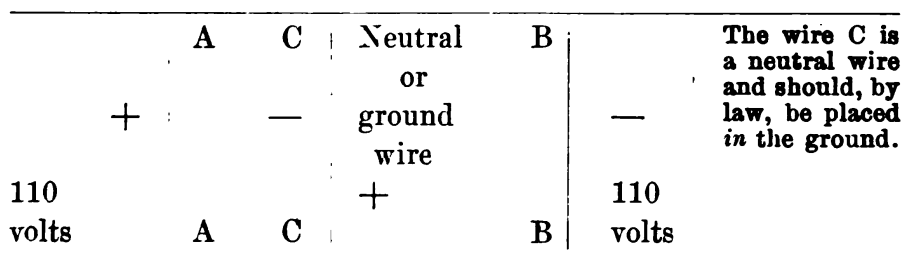

Fig. 9.—Diagram of three-wire system.

If we connect A and C, we get 110 volt-current.

If we connect B and C, we get 110 volt-current.

If we connect A and B, we get 220 volt-current.

At the new Jefferson Hospital, A and B are connected, and thus we get a 220 volt-current. All electrical apparatus used in Jefferson Hospital had to be arranged especially for the 220 volt-current.

In the above diagram A is positive to C or to B.

If we connect A and C, we have A positive and C negative.

If we connect C and B, we have C positive and B negative.

If we connect A and B, we have A positive and B negative.

If we use the three-wire system, it is very important to select the right wires and also to place, in the proper position, an efficient controlling apparatus. In some cases, the neutral wire C does not lead to the ground, as the law requires, but is simply grounded, by attachment to some gas or water pipe. If a three-wire system is introduced into a house, we should be sure that the neutral wire is *conducted to the ground* and that it is *not grounded* by means of a gas or water pipe. The three-wire system is used as a matter of economy to the electric companies. In using 110 volts a greater percentage of loss is found than when 220 volts are employed. This is especially true when currents are carried a long distance. It is easily

comprehensible that the patient holding an electrode in one hand and then touching a gas or a water pipe, to which the middle or third wire is grounded, will at once receive the full 110 volt-current unless an efficient controlling apparatus has been properly placed.

### THE PILE.

If we take a plate of zinc and another of copper and place both in acidulated water, we form a cell; now, if we make another

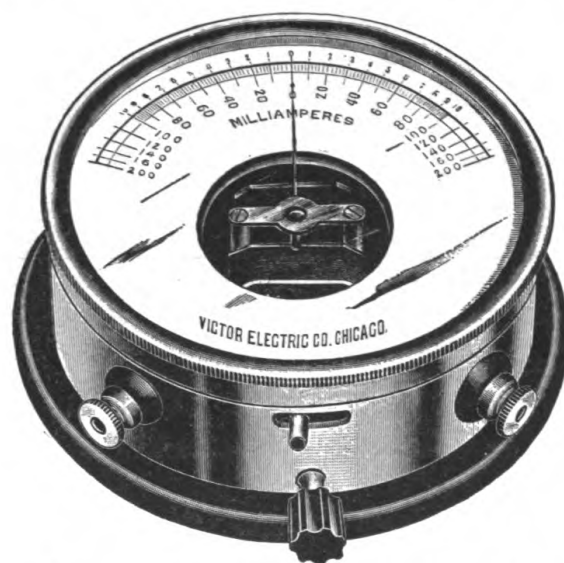

Fig. 10.—Milliampèremeter. (Victor.)

such cell, and connect the *first zinc* with the *second copper* by means of a copper wire, we have formed a simple pile.

The original voltaic pile was formed by the superposition of a number of couples. \* Each couple was composed of a disk of zinc and a disk of copper, separated by a disk of cloth which was saturated with acidulated water.

If now we remove a couple and place the parts in a glass vessel filled with acidulated water, we have our present galvanic, or voltaic cell. *Outside* the cell the current flows *from the copper to the zinc*, but *inside* the cell it flows *from the zinc to the copper*. The difference in potential between zinc and copper gives the electro-motive force of the cell.



The E. M. F. of a cell depends upon the metals used and *not* upon the size of the plates. We should not forget, however, that the *internal* resistance is diminished by using larger plates and by placing them closer to each other.

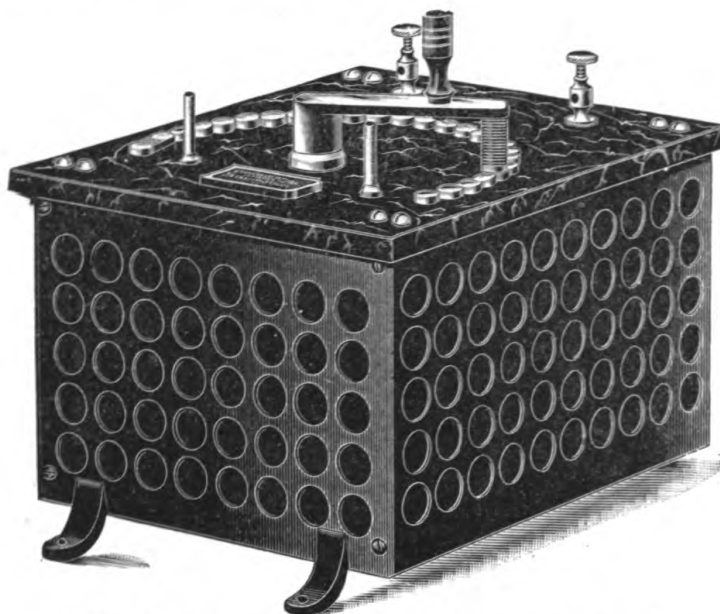

Fig. 11.—Twenty-five point rheostat. (Victor.)

A perfect pile should have:—

1. Great E. M. F.
2. Small *internal resistance*.
3. Constant E. M. F.
4. Cheapness.
5. Cells so arranged that they may be easily cleaned.

### CONDUCTIVITY OF LIQUIDS.

Liquids may be divided into:—

1. Those that conduct like solids, as do all metals in a liquid state, whether like *mercury* at ordinary temperatures, or like *iron* fused at a high temperature.
2. Those that do *not* conduct at all, such as pure water, pure hydrochloric acid, fluid chlorine, bromine, and iodine, oils and resins, and gases and vapors.

3. Those that conduct, but only with chemical decomposition, such as dilute acids, compounds of two elements, and compounds derived from them by double compounds.

### THE METER.

Every electro-therapeutist should have a milliampèremeter. No druggist would think of measuring medicine in an ordinary tumbler instead of in a graduate and no physician would think

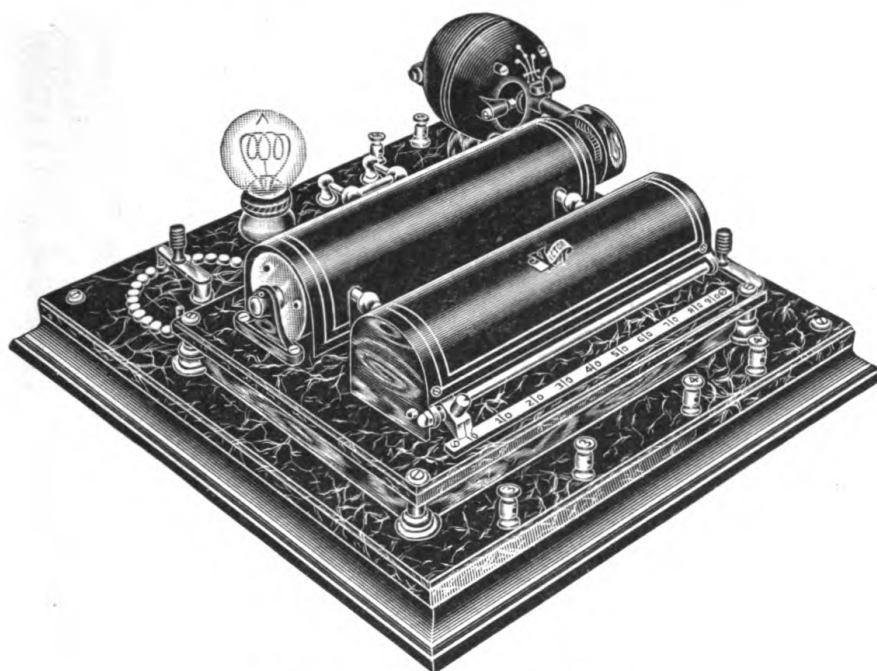

Fig. 12.—Multiplex. (Victor.)

of sending prescriptions to such a druggist. Yet physicians will employ electricity—as a remedy—without knowing the amount of electricity used. It does not mean anything to say we are using 6 cells; nor can we tell anything about the amount of electricity used by the sensation experienced by the patient; one person may endure a current of 18 milliampères while another may say a current of 5 milliampères is too strong. It is a well-known fact that nervous women take but small quantities of electricity at first. In using a good meter, we turn on the cur-

rent until we get the proper dosage, irrespective of the number of cells employed.

We should not confuse voltmeter and voltameter. There is in electricity the *voltmeter* which is used to measure the *current*

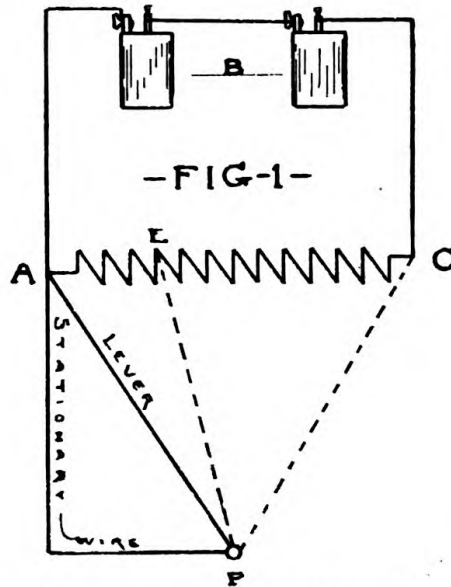

Fig. 13.—Diagram of rheostat. (Victor.)

*pressure* or voltage; one of the best is the Weston. We also have the *voltmeter* which is based on the experiments of Faraday who concluded that the quantity of electrolyte decomposed is directly proportional to the strength of the current.

#### THE RHEOSTAT.

A rheostat is an instrument used to furnish resistance, that is, for controlling the strength of current. It is accomplished



Fig. 14.—Nickel-plated metal handle.

by decreasing the ampèreage and by furnishing heat. By means of a rheostat one may increase or decrease the resistance in a circuit at will. The rheostat may be made of wire or of graphite.

Part of the electricity is converted by means of a rheostat into heat. We should remember this when using a rheostat for a long time, otherwise a child or other bystander might receive an ugly burn through touching the hot rheostat.

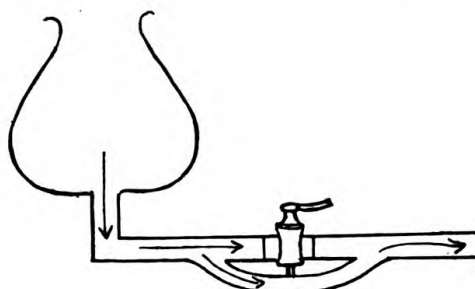

Fig. 15.—A “by-pass.”

At one time the rheostat was of the *series variety*. At the present time the *shunt variety* is used. A shunt is merely a loop off the main current, and is the same as a “by-pass” attached to a water pipe.



Fig. 16.—Victor universal handle, with interrupter.

Two kinds of shunt rheostats are used, one being of graphite and the other of wire in coil. The last named is much preferable.

The objections to the graphite rheostat are:—



Fig. 17.—Hard rubber needle holder, with interrupter.

1. Graphite heats. Hence the resistance will decrease—a well-known fact being that the resistance of carbon is decreased by heat—and consequently the meter will register higher.

2. It is impossible to keep the resistance constant, even though the operator persists in adding or taking off graphite.

A striking example of the uncertainty of the graphite rheostat was given to the author when using such a rheostat recently. The current was turned on gradually, but the meter

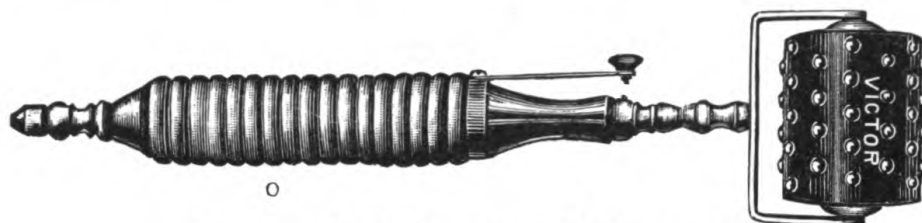

Fig. 18.—Wheel electrode, with interrupter.

did not register for about three minutes, and no current was felt. Then, suddenly, the meter registered 18 milliamperes and the author's arms were violently jerked. The current was turned off and another trial was made, when the current suddenly jumped



Fig. 19.—Hard rubber needle holder.

to 20 milliamperes. The wire rheostat is always to be preferred, notwithstanding the statements of enthusiastic salesmen.

In selecting a wire rheostat we should be sure that it has an ample heat-radiating surface. In a carbon rheostat, the carbon heats too quickly and, besides, becomes unevenly distributed,



Fig. 20.—Hemorrhoidal needle holder.

thus giving at one point too great resistance and at another too little, thus producing an unequal resistance. The voltage and ampèreage may both be controlled and regulated by placing a *limit resistance* at the *point of entrance* of the *current*; the current is then shunted by means of a resistance cylinder, which is placed in the main circuit.

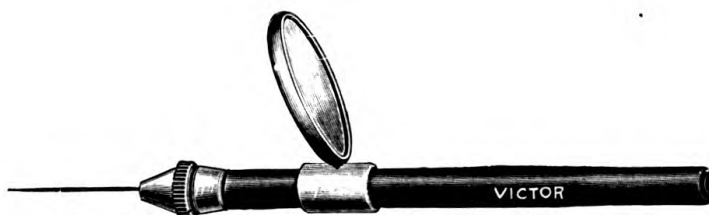

Fig. 21.—Needle holder, with magnifying glass.

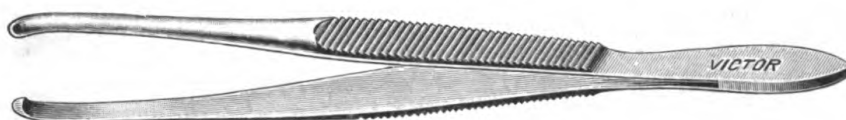

Fig. 22.—Depilatory forceps.

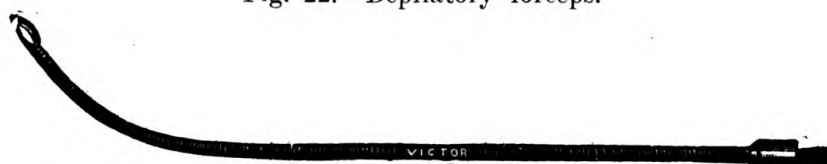

Fig. 23.—Laryngeal electrode, nickel-plated, insulated.



Fig. 24.—Universal handle, with sponge covered disc.

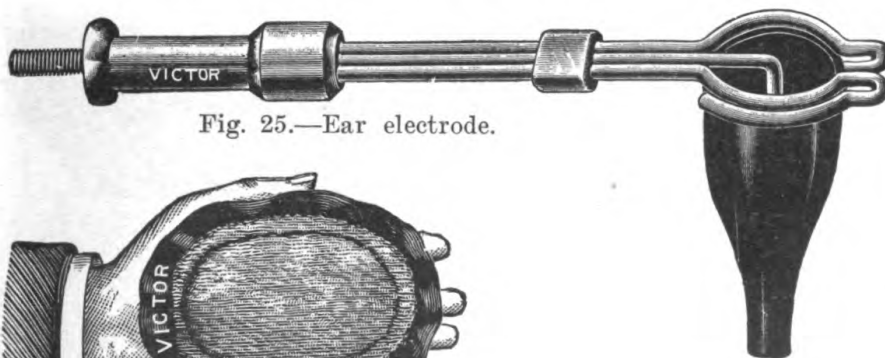

Fig. 25.—Ear electrode.

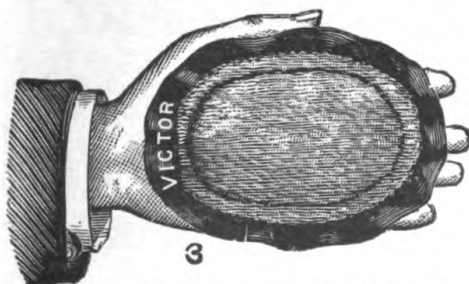

Fig. 26.—Sponge covered electrode.

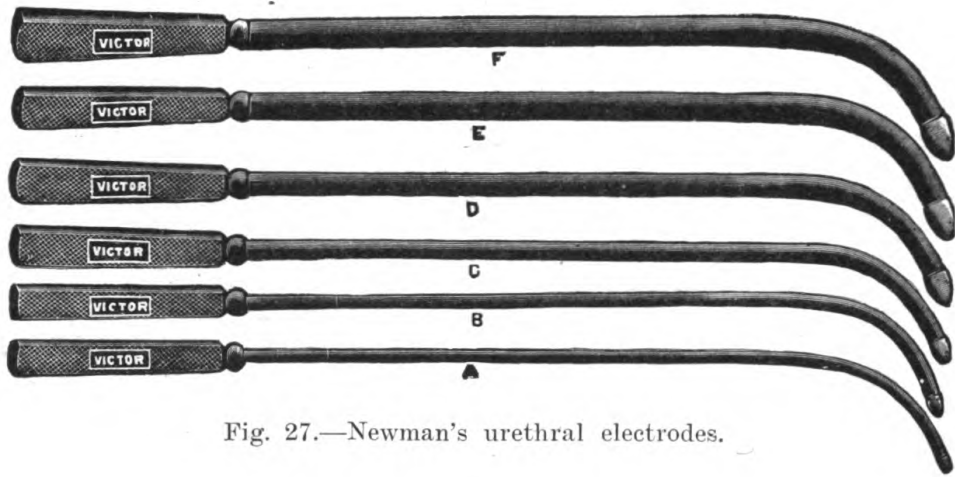

Fig. 27.—Newman's urethral electrodes.

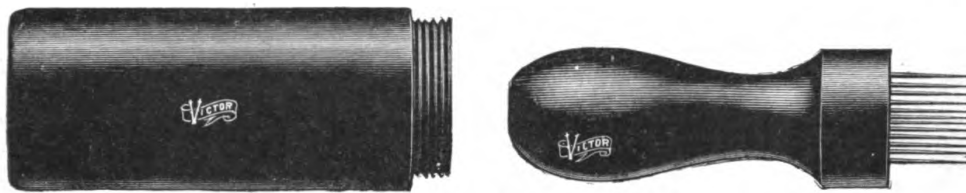

Fig. 28.—Needle disc, for removal of nevi.



Fig. 29.—Double copper intra-uterine electrode.

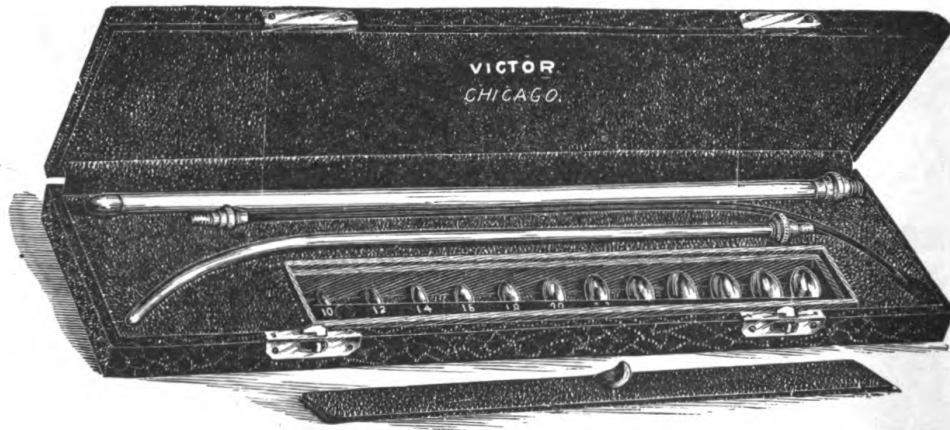

Fig. 30.—Genito-urinary electrode case.

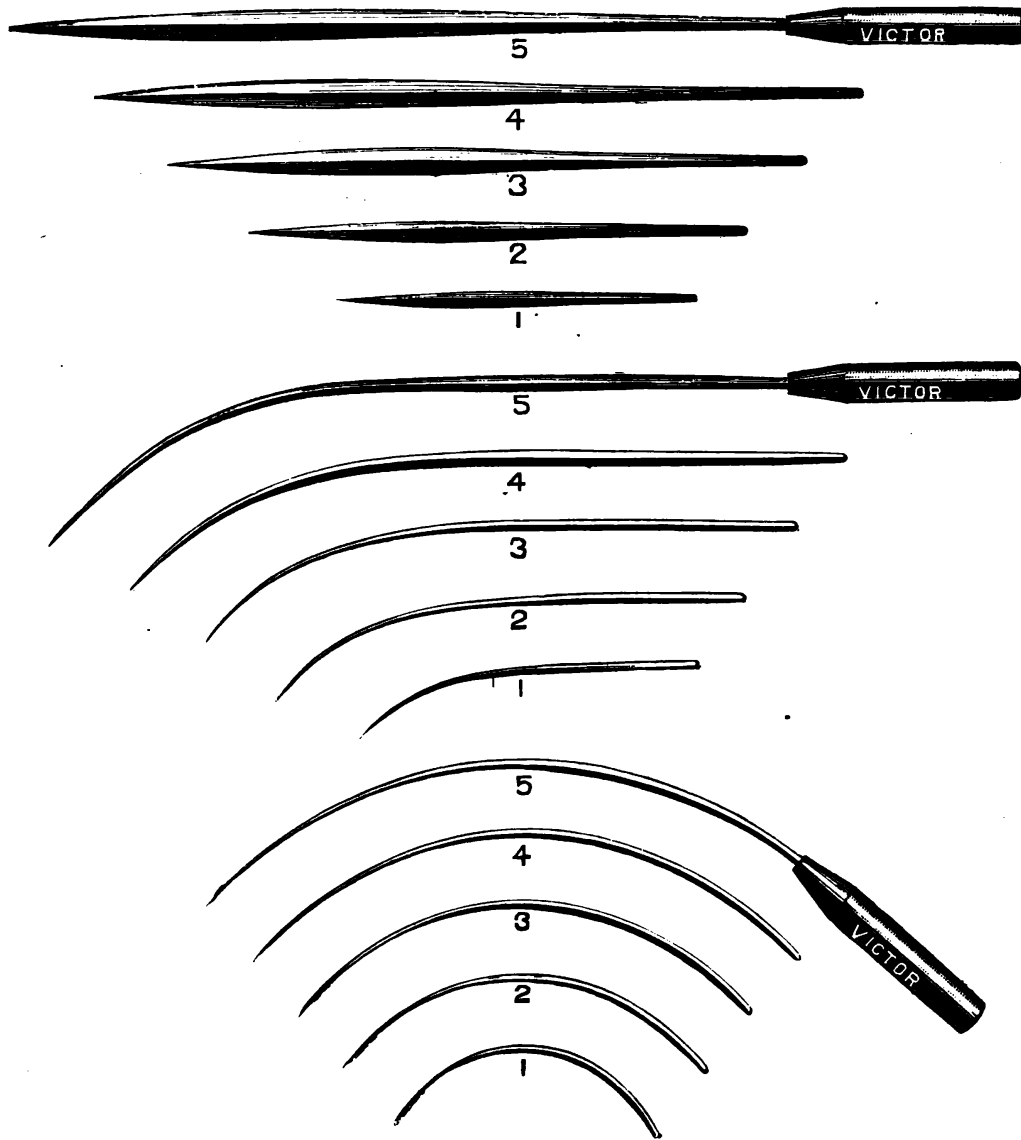

Fig. 31.—Gold-plated needles for electrolysis.



Fig. 32.—Uterine electrode, insulated with hard rubber.



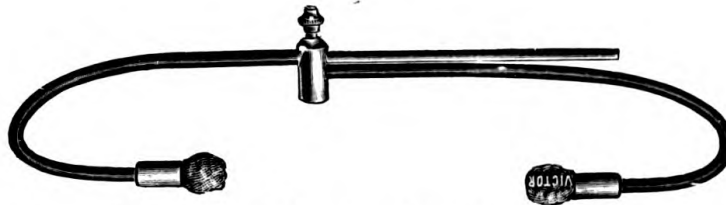

Fig. 33.—Double ear electrode, insulated.

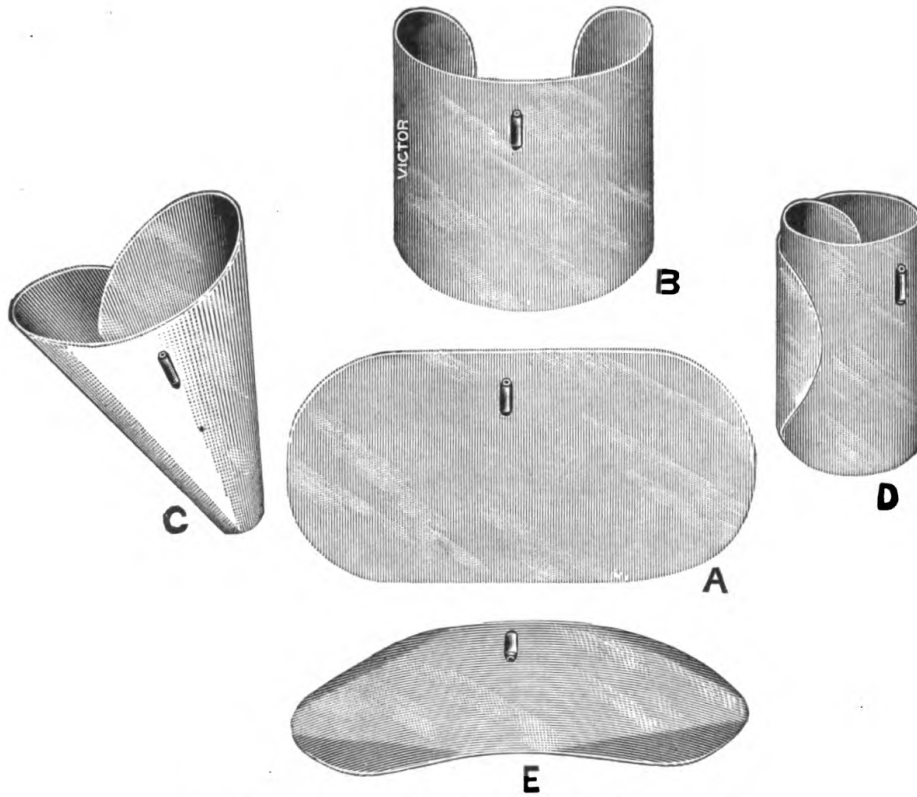

Fig. 33<sup>a</sup>.—Universal electrode, flexible metal.



Fig. 34.—Double eye sponge electrode.



Fig. 35.—Eye cup electrode.

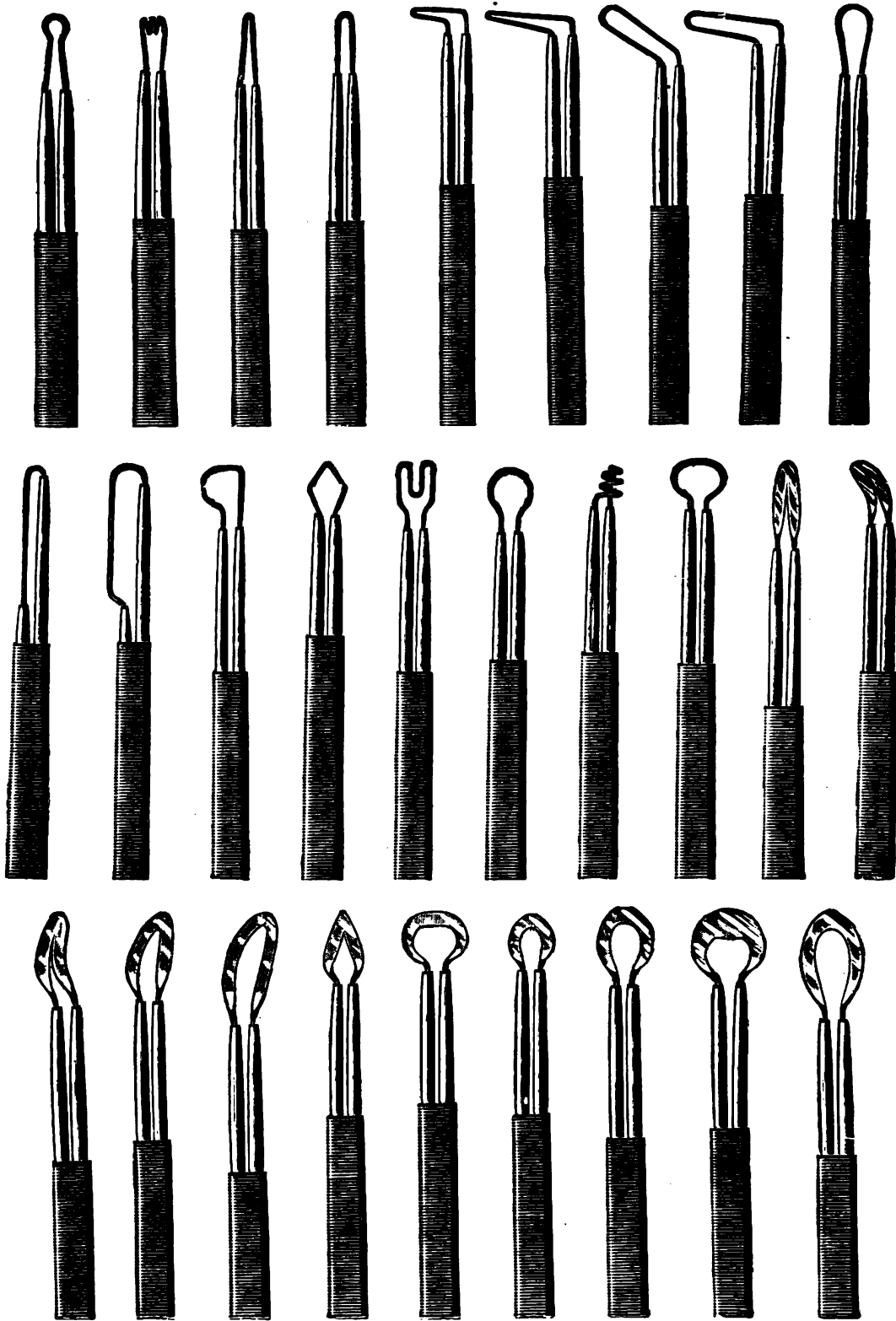

Fig. 36.—Victor cautery electrodes.

## CHAPTER III.

### STATIC ELECTRICITY.

---

THE medical history of static electricity may be divided into two epochs, the first extending from 1734, when Abbé Nollet drew the first spark from the human body, to 1880; the second from 1880 to the present time. Prior to 1880 the static machines had very little therapeutic value, for they were frictional machines. The only methods of treatment by this type of machine were "the spray," "the bath," the spark, and the Leyden jar shock.

In 1880, Professor William J. Morton, of New York, brought to this country a new form of static machine known as an influence machine. This is the machine now generally used by physicians. To Dr. Morton, we are indebted for the static induced current, which is the first high frequency current ever used; the Morton wave-current; and indirect franklinization, or as it is known by the French, the "mediate franklinization." The currents known as the d'Arsonval current, the Tesla current, and the Oudin current are all modifications of Morton's static induced current.

A static machine is always building up new charges, passing from zero to a very high potential. If a machine is producing a spark of one inch in length, the voltage is calculated as 30,000. In order to ascertain approximately the voltage of any static machine, one has but to multiply the length of the spark in inches by 30,000 volts, *i.e.*, a three-inch spark would indicate 90,000 volts.

The greater the number of revolving plates the greater will be the ampère.

The greater the speed of the revolving plates the greater will be the ampère.

The greater the diameter of the revolving plates the greater will be the voltage.

**STATIC MACHINES.**

The static machine was invented in 1647, by Otto von Guericke, of Germany. This machine laid the foundation for the *influence* machine now in vogue.

In the *influence* machine we must have (1) *influence* by which a conductor, on being touched, acquires a charge of the *opposite* kind, and (2) *reciprocal* accumulation.

In the *Wimshurst* influence machine we find two circular disks of glass placed about one-sixth of an inch apart. The disks are made to rotate in *opposite* directions. The machine is very efficient.

In the *Holtz* machine we find two glass plates, one having a slightly larger diameter than the other. There are two "windows" in the fixed plate, directly opposite the ends of a diameter. In order to start this machine it becomes necessary to bring the knobs of the discharging rods together and to charge one of the field plates from an outside source.

Another kind of machine is the *Voss* or *Toepler*, which resembles the *Holtz* in many respects; it is not so certain in action as is the *Wimshurst*. In the United States nearly all the static machines are a modification of the *Holtz*, known as the *Toepler-Holtz* machine.

In some sections of this country, especially in the East, the *Holtz* machine, with a small *Wimshurst* excitor is used.

**ELECTRODES FOR STATIC MACHINES.**

They are of metal, of wood, or of glass. The wooden ones, known as discharge electrodes, are not often used. The metal electrodes are of brass and are made in different shapes. The glass electrodes are glass vacuums. A universal handle of ebonite is used. There is always a hook attached to an ebonite handle for holding the chain which conducts the current from one pole of the machine to the electrode. It is used to keep the chain from coming in contact with the patient and thus causing shock.

## PROPERTIES OF STATIC ELECTRICITY.

This form is also known as frictional, or Franklinic electricity. Static electricity is often termed electricity *at rest* but is really electricity under tension. There are *positive* and *negative* electricities. All static machines have for their object the separation of these two forms of electricity and are composed of two parts, one for generating electricity and another for accumulating it.

Because it was known that electricity at rest, or static electricity, resides on the surface of bodies charged with it, it was formerly thought that static electricity never produced any effect upon the deeper tissues. It remained for Dr. William J. Morton, of New York, to disabuse the minds of physicians on this point.

The static current has exceedingly *small volume* but *immense pressure*. The principal features of the static current are that it is *unidirectional* and is of very *high potential* but of very *small quantity, i.e., high voltage* but *small ampèrage*. The amount of current is so small that very high potentials, as much as one hundred thousand volts, can be safely used on a patient. The reason for the small current is the very high internal resistance of the machine. For electrolytic purposes the static current need not be considered. The current in static machines varies from ten thousand to five hundred thousand *volts*, the ampèrage from  $\frac{2}{10}$  to 3 milliamperes.

The static machine gives a high potential difference but a very small current. It is to be hoped that in the future some one will invent a static machine which will furnish a current of *high voltage* and also a *large quantity* of electricity.

Two kinds of static machines are used by electro-therapists, one with glass plates and the other with fibre plates. Each kind has its advocates.

When first using static electricity we should be very cautious, as some patients have a decided idiosyncrasy to this form of electricity. The static head breeze, for instance, may cause dizziness. We should always use a weak current for only a few minutes until we become acquainted with the peculiarities of

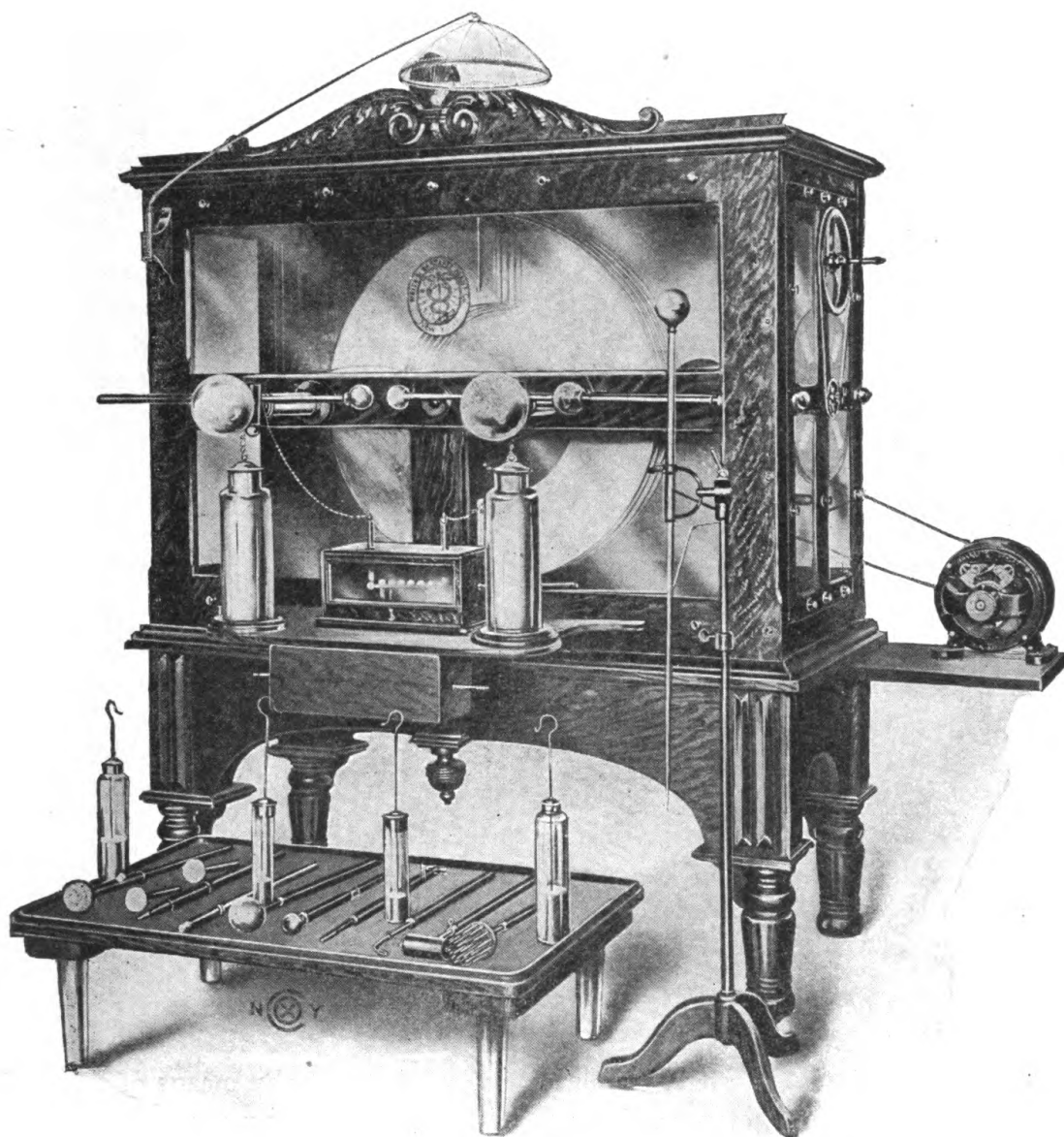

Fig. 37.—Waite and Bartlett's static machine.

the patient. Applications will differ much as to the strength of current and the number of treatments required per week. Patients will often ask the physician how many applications will be required. We should be guarded in our reply. Some patients respond quickly to treatment, while others do not. Much will depend on the disease, the susceptibility of the patient, the strength of current used and the number of applications given weekly.

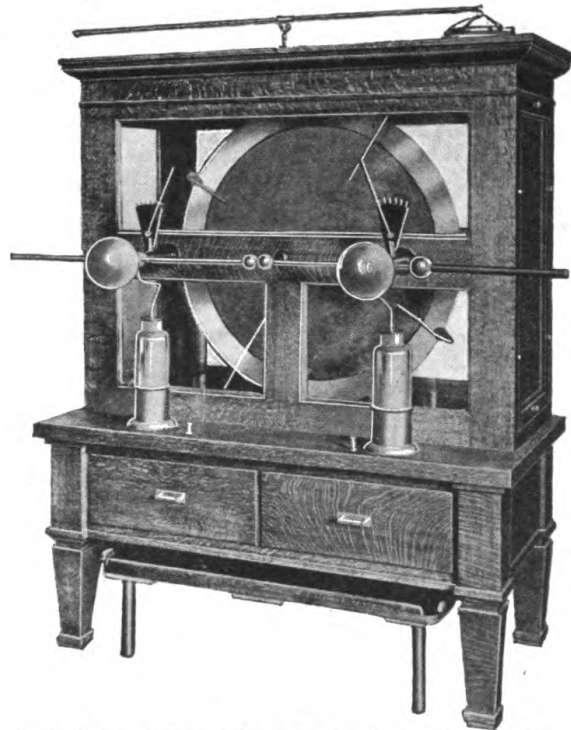

Fig. 38.—Baker Electric Co.'s static machine.

In *galvanic* electricity the cure is effected chiefly by means of electrolysis.

In *static* electricity the cure is effected mainly by means of the rise and fall of potential, *i.e.*, by the explosive power, which produces a sort of tissue gymnastics. Static electricity may be administered in a number of ways.

It is a fact very well known to electro-therapeutists that when we do *not* get good results from one form of *static* electricity, we may get brilliant results from an application of another form of static electricity.

It is well to speak here of the claim made by non-electro-therapeutists that the real good in static treatment comes from suggestion. If this were so, we would not get better results when we change our method of applying the static current. We would besides get our best results from using the rapidly interrupted faradic current. As a matter of fact we are enabled to help patients by static electricity even when the faradic and the galvanic currents absolutely fail to do any good.

Static electricity is an equalizer of nerve forces. It helps very greatly in the elimination of urea and of all other waste products, besides dilating the cutaneous vessels; it increases the frequency and regularity of the pulse, and raises blood-pressure; under the influence of static electricity, sleep returns and the appetite improves.

The general effects of static charging are: (1) To raise blood-pressure; (2) to increase the frequency and regularity of the pulse; (3) to stimulate metabolic processes; (4) to cause a return of sleep, and (5) to improve the appetite.

Excellent results have been obtained in neurasthenia, in melancholia, in the nervous disturbances which accompany the menopause, in mental fatigue, in insomnia, and in menstrual irregularities. The sensory effects are seen in some forms of headache, in neuritis and in neuralgia. Sparking often relieves lumbago and deep-seated muscular pain. We should not forget to employ the static treatment in cases of neurasthenia and hysteria *with low* blood-pressure, but *not* in cases with high blood-pressure.

Very high insulating materials are employed in static machines. The *poles* of the static machine are known as the *prime conductors*. To these are sometimes attached *Leyden jars*, so-called because this form of electro-static condenser was invented about 1750 by Vanleight, in the town of Leyden.

#### LEYDEN JARS.

The common form of Leyden jars consists of a glass bottle coated, inside and out, with tin foil to within a short distance of the top. This bottle is closed with an insulating material through which passes a wire. At the outer end of the wire is



mounted a metallic knob. The lower end of the wire is connected to the inner coating by means of a brass chain. The external and internal tin-foil surfaces are the *conductors* and are sometimes called the *armatures*, while the *glass* is the *dielectric*.

If we charge the inner coating, this charge acts inductively on the outer. In order to discharge the jar, we place a bent wire against the outer coating; now, while this end is being held against the outer coating, the other end of the wire is slowly

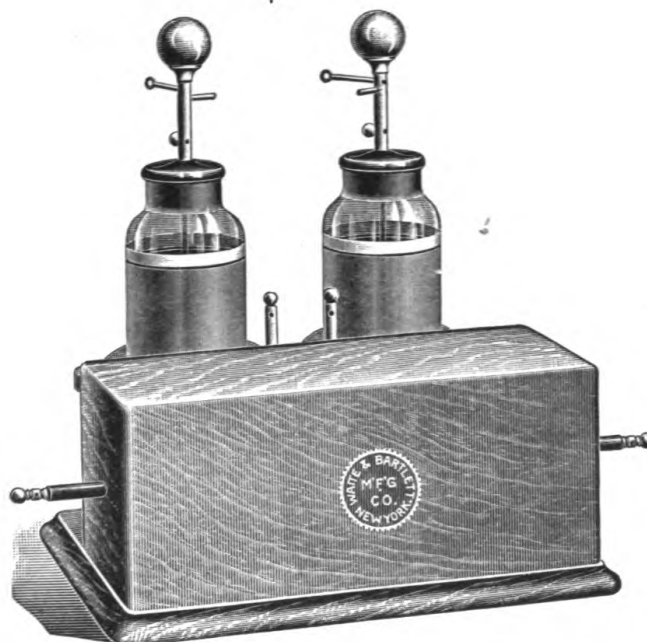

Fig. 39.—Leyden jar. (Waite and Bartlett.)

brought toward the knob. Very soon a spark passes between the wire and the knob and we say that the jar has been discharged. The Leyden jar is in reality but a rolled-up fulminating pane or Franklin plate.

The jars may be connected in multiple. If we connect all the outside coatings with each other, and all the inside coatings with each other, we connect the jars in multiple and obtain an *increased* quantity of electricity.

To charge a Leyden jar we require *not* a large *quantity* of electricity, but a high *potential difference*.

**DISCHARGES.**

In electro-therapy we are enabled to utilize discharges that may be *convective*, *disruptive* or *conductive*.

When electricity of a high potential discharges itself at a pointed conductor, there will be what is known as a convective discharge. The *breeze*, the *spray*, the *static bath*—from metal electrodes—and the high frequency discharges from glass vacuum electrodes are all forms of *convective* discharge.

The *long*, *short* and *friction* sparks furnish examples of *disruptive* discharge.

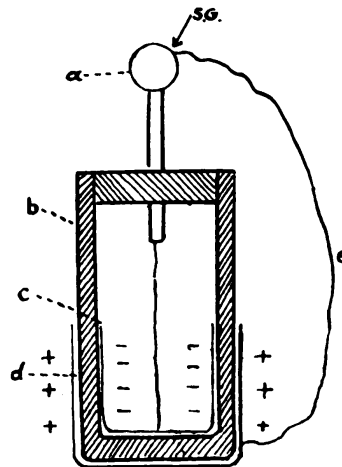

Fig. 40.—A Leyden jar.

The *conductive* discharge is obtained from an electrified conductor. This may be derived from a thin wire connecting the knobs of a static machine, or by joining the positive pole of a battery to the negative pole.

**DRYING A STATIC MACHINE.**

The electric current, acting on the air inside the case, produces a nitrous oxide which, uniting with the oxygen, forms nitrous acid compounds. These compounds, being acid in character, affect the working parts of the machine. Wagner recommends the placing of a dish, containing boiled linseed oil, inside the case, in order to take up the nitrogen. If any acid

deposits are found they may be removed by means of ammonia water.

We may place sulphuric acid in wide, open, and deep dishes on the floor inside the case. Each dish should only be half filled because the moisture taken up by the sulphuric acid increases the quantity of fluid.

Wagner also introduces ventilators into his machines in order that the nitrous oxide vapors may be carried off.

In order to overcome the difficulty as regards moisture, some operators have placed incandescent lamps inside the glass case, thus furnishing heat; others use chloride of calcium, caustic soda, or caustic potash; jars containing cracked ice and table salt may be placed inside the glass case to cause a precipitation of the moisture upon the sides of the jars.

A clean, dry cloth may be used to remove dirt from the plates; or, if the plates are very dirty, a little gasoline may be applied.

#### TESTS FOR POLARITY ON A STATIC MACHINE.

1. Start the machine and separate the prime conductors *one-half inch*; the *positive* will be indicated by the *white* end of the spark—because incandescent oxygen is *whiter* than incandescent nitrogen—while at the negative we see a violet light. If the prime conductors are separated *several inches*, the heavy white end will be on the *negative* side, *not on the positive, as before*.

2. If a non-conductor be applied to the *positive* pole there will be a discharge; none will be obtained from the *negative*.

3. When placed in a horizontal position the *positive* gives off a hissing sound.

4. In a darkened room the *negative* will give to the collecting combs a brush-like form; the *positive* will give points of light.

5. In using the head spray, the crown, if *positive*, acts as an anesthetic and a contractor of the blood-vessels; if *negative*, it is an irritant, and dilates and liquefies.

6. When looking at a static machine in a dark room, a star

appears at the *positive* point, while at the *negative* point is seen a spray.

7. If the machine is in action and a burning candle be placed *between* the prime conductors, the flame of the candle will be diverted *toward* the *positive* pole.

If we wish to change the polarity of a static machine, we should ground both poles; now, we give the plates a few turns in the opposite direction, and then start the machine as before.

### LOSS OF CHARGE IN A STATIC MACHINE.

A static machine is said to have "lost its charge" when the machine fails to generate electricity.

A static machine may lose its charge (1) by having its plates turned the wrong way; (2) by having dirt on the plates; (3) by having moisture deposited on the plates; (4) by degenerated shellac; (5) through the grounding of both poles by leaving the chains hanging from the poles to the floor; (6) the plates may not revolve properly because they have become loosened from their axle; (7) the combs may have become displaced so as to touch the glass, or may not be in proper relation to the paper collectors.

### POTENTIAL.

We use the word *potential* in electricity much as we would use the words *pressure* in *gases*, *head* in *liquids*, and *temperature* in *heat*.

As water at a higher level seeks a common level by flowing toward the lower level, so electricity tends to flow from a *higher* to that of a *lower potential*.

It has been arbitrarily assumed that the *positive* is at a *high* potential and the *negative* at a *low* potential, consequently—as in the case of flowing water—the current flows from the *positive* to the *negative*, or from the *high* to the *low*.

If we wish to use an *ascending* current on the human body, we place the *positive* electrode upon the periphery of a nerve and the *negative* over the nerve centre; in this case the current will travel from the *positive* to the *negative*—*i.e.*, ascend. In using

a *descending* current, we simply reverse our electrodes, placing the *negative* upon the periphery and the *positive* over the nerve centre.

Some authors lay great stress on the direction of the current. The writer does not believe it makes much difference in which direction the current flows. It is *very important*, however, to place the electrodes properly when testing for reaction of degeneration, or when treating some local trouble, as in the case of eye diseases. In treating a case of optic atrophy we apply the *negative* electrode near the eye in order to secure the following results: (1) as a stimulant; (2) to quicken absorption; (3) to increase moisture; (4) to dilate blood-vessels and lymphatics.

We should remember that the *potential of current electricity* is *very small* while the *potential of static electricity* is *very large*. It has been estimated that 30,000 volts are necessary to produce a spark one inch in length. Some *static* machines are able to produce sparks several inches in length. A strong galvanic battery is not able to produce a spark of more than three-hundredths of an inch in air. Now, if we measure the *actual quantity* of electricity by the effects in decomposing water, we will find that a large static machine will *not* decompose as much water as will a very small galvanic cell.

There are several ways of applying static electricity such as *static insulation*, direct and *induced* sparks, the *static induced* current—by means of Morton's *pistol electrode*—the *single* or the *multiple spray*, *roller massage*, the *head breeze*, the *Morton wave-current*, and the *new spray* or *pencil discharge*.

#### THE METHODS OF APPLYING THE STATIC CURRENT.

**The Electric Bath.**—The negative pole should be connected *to the ground* and *never* to the *patient* as some books teach; then withdraw the discharging rods. This simple electric bath has no special electro-therapeutic value.

**The Electric Spray.**—The *negative* pole should be grounded; the positive pole should then be connected with a pointed metallic electrode, held in the hand of the physician.

The spray may be applied to any part of the body. The sensation is that of a breeze blowing on the body. If we bring the point of the electrode in contact with the flesh, we will cause an intensely white spark, and ozone will be liberated. This method may be used for the abortion of carbuncles and furuncles, and for the treatment of moles, warts and acne. By using an inverted crown electrode the electric spray may be applied to the head, being especially useful in the treatment of neurasthenia. The electric spray affects the pulse and produces metabolic changes.

**The Electric Spark.**—The spark is used in treating sciatica and neuritis of the rheumatic type. By means of the ball electrode it is possible to give a nagging spark or a long, clear spark. Dr. Morton recommends using the long, live, explosive spark. By applying this spark over the deltoid, the sensation will be felt from the mastoid all the way down the shoulder; by applying over the thigh, the sensation will be felt from the buttocks down to the tip of the toe. In locomotor ataxia we may use the friction spark with great benefit as a counterirritant.

We should remember that the above named treatments are given with a *grounded* pole.

**The Morton Wave-Current.**—It is doubtful whether there is one electro-therapeutist in this country who has not at some time employed this wave-current. It is probably the most useful form of static current known. In using the *static induced current* the patient is *not* insulated. In administering the *wave-current* the patient is *seated on an insulated chair*. A “block-tin” electrode, of any desired shape and size, is placed *directly against* the skin. As will be seen by the diagram, the negative pole is grounded, while the positive pole is connected with the electrode, which is against the skin. We should note that the patient is on an insulated platform. We should now separate the prime conductors very slowly until the patient’s limit of resistance is found; we should continue the treatment for 20 minutes and give three treatments weekly. We should *not* use Leyden jars in giving the Morton wave-current.

The wave-current may be intensified and varied—as suggested by Dr. Morton—by using an “external insulated capacity”

and by making different connections, employing a single Leyden jar.

Dr. Snow's excellent work "Manual of Electro-Static Modes of Application" describes the method as follows: "The wave-current may be intensified and varied in this manner:—

"1. When it is desired to intensify or localize the current by employing an 'external insulated capacity' (see Fig. 41 below), it may be accomplished in the following ways: (a) A

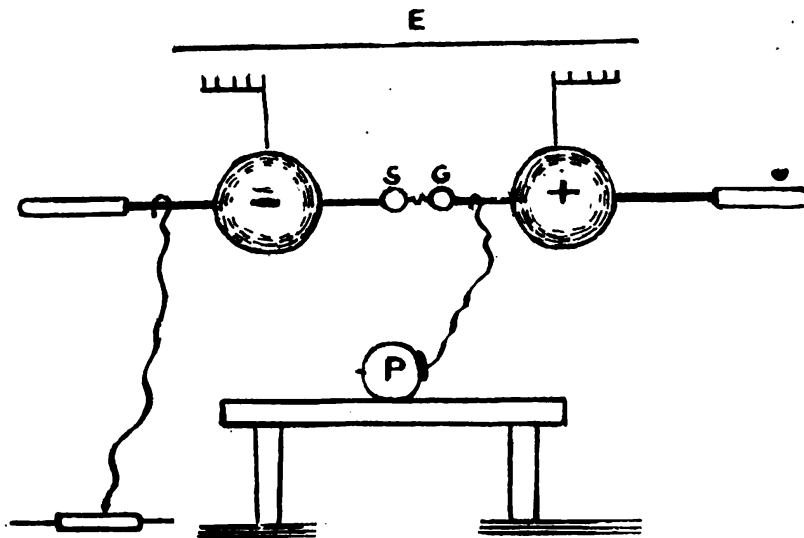

Fig. 41.—Wave-current. (Morton.)

metal sheet is suspended upon an insulated stand or by insulating material, as a cord, from the point of the standard electrode, to which a rheophore passes from an electrode placed upon the patient, who has previously been connected by an electrode and rheophore to the machine by the usual method of administering the wave-current. (b) By making use of a chair having glass castors or other insulation (as telegraph insulators) beneath the legs, the chair placed upon the insulated platform, the patient being seated on the chair with his feet placed upon the metal plate which is placed upon the platform, the patient at the same time having the usual connections for the application of the wave-current.

"2. A current of remarkable potency may be produced by modifying the wave-current as follows: The usual connections having been made and the electrode placed upon a surface requiring an intense local application, place a second electrode or plate indifferently on any part of the body or on a part requiring a milder local treatment, and connect the latter electrode or plate with the inner coating of a Leyden jar, the outer coating of which is connected by direct metallic connection with the earth. The spark-gap between the balls of the discharging rods will be employed to control the current strength.

"With these currents, above described, the intensity of effect produced upon the patient is greater on the side connected

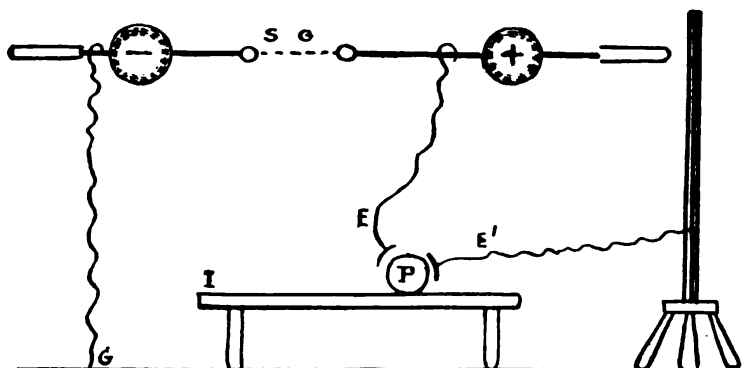

Fig. 42.—The wave-current intensified. (Morton.)

with the machine than on the side connected with the 'external capacity' or the Leyden jar having a ground connection from the outer coating.

"In these modified currents the administration is made with the patient insulated and the effect is local to a marked, and constitutional to a very moderate, degree. Whereas the unmodified wave-current is constitutional in a very large measure, but requires more energy in the static machine to produce the same degree of local effect.

"The intensity of these currents may be varied with the size of the 'external capacity,' the size of the Leyden jar, the size and proximity of the electrode, or the length of the spark-gap and the speed and capacity of the machine."



As a great deal of misunderstanding seems to exist as to how the wave-current should be administered, I give here Dr. Morton's own words:—

“One prime conductor of the static generator is grounded; the other is connected with an electrode applied to the patient, who is on an insulating stand. The current received by the patient is due to the spark discharge between the knobs of the prime conductors. The patient forms one coating of a Leyden jar condenser, the other coating of which is the earth and surrounding objects and walls connected electrically therewith. The greater part of the charge and resulting strain on the dielectric air will be found at those parts of the patient and floor or walls of the room that are nearest together.

“If the spark-gap be long, the time of charging by the small continuous current will also be comparatively long, because the potential must be raised to a high point in order to produce a long spark. The duration of the discharge, which will probably be an oscillatory one of relatively high frequency because of the small capacity of the condenser, will be short. The small continuous charging current will flow through the patient, without causing any appreciable sensation. The sudden oscillatory discharge may flow over the surface of the patient because of its high frequency, and therefore without disagreeable effect. As the length of the spark-gap is diminished, the time and amount of charge becomes less, with a resulting diminution of sensation.

“The arrangement is essentially that of a transmitter of wireless telegraphy; one side of the oscillator is grounded and the other is an insulated condenser plate. Such an arrangement may be a radiator as well as an oscillator and thus permit of the radiation of Hertzian waves from the patient's person; hence the suggestion to use the name wave-current.

“The current may be modified to produce gentle, painless and diffusive muscular contractions or not, as desired. It is obvious that each spark passing may represent such a contraction and these are often desirable.

“If the resistance of the spark-gap is diminished the fre-

quency is augmented. The spark should pass in a well-sustained and (to the eye) continuous stream."

It is well to remember that the wave-current is especially employed to lessen hyperemia and congestion and to relieve pain.

**Static Insulation.**—The patient is placed upon an insulated platform and his feet rest upon a large, flat electrode which is connected to one pole of the machine by means of a chain. This chain should *not* touch the floor. We should remove the Leyden jars. We should now ground the other pole of the machine by connecting a chain with a gas fixture or a water pipe. If no gas fixture or water pipe be convenient, the pole may be grounded by simply dropping the free end of the chain upon the uncarpeted floor. We should now separate the poles of the machine until no sparks are seen, and put the machine in rapid motion, when the patient will receive static insulation. In giving *static insulation*, if the patient is connected with the *positive* pole while the *negative* pole is grounded, the patient receives *positive static* insulation. To give *negative static insulation* we simply reverse the polarity. *Static insulation* is one of the most widely used forms of *static electricity*.

**The Static Head Breeze.**—Another popular form of static electricity is the head breeze, which is also known as the concentrated brush discharge or spray. The arrangement is the same as for static insulation, with the exception that the pole which was grounded is now connected with an electrode in the form of a large, inverted crown, which is placed about two feet above the patient's head. *No* Leyden jars are used. Usually this treatment is most pleasant to the patient, who describes the sensation as of a breeze blowing upon the head. The hair stands erect when the breeze is applied. We should remember, however, that in some patients there is produced a dizziness by the head spray.

If the crown is connected to the positive pole—which has been grounded—and the negative pole is connected to the large electrode placed under the patient's feet, the patient will receive a *positive* breeze. If we wish the patient to have a *negative* breeze, we connect the *crown* to the negative pole—which has

been grounded—while the positive pole is connected to the large electrode placed under the patient's feet. Applications should last from fifteen to twenty minutes.

If we wish to produce an anesthetic effect, or to contract the blood-vessels, we connect the crown to the grounded *positive* pole of the machine; if we wish to irritate the scalp and dilate the blood-vessels, we connect the crown to the grounded *negative* pole. In migraine and cerebral hyperemia we use the *positive* breeze. If we wish to treat a case of headache due to anemia we connect the crown with the *negative* pole.

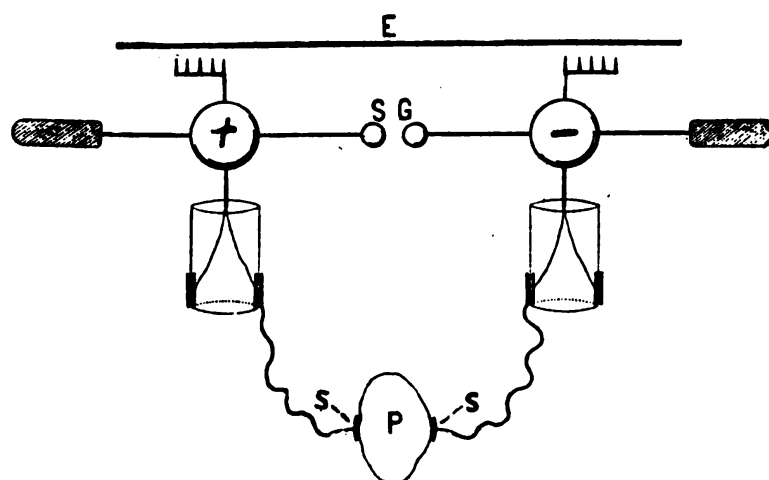

Fig. 43.—Static induced current. (Morton.)

We should remember that metal hairpins may cause unpleasant sensations in the head and so frighten timid patients. We should never permit a patient to wear celluloid hairpins, while taking a treatment, as these pins are very inflammable.

#### THE STATIC INDUCED CURRENT.

This form of static electricity—for the elaboration of which the medical profession owes a great debt to Professor Morton, of New York—is obtained from the outside coating of the jars. Morton's pistol electrode is used in this modality; but, for that matter, it may be used with any static current. This current is very useful in constipation, painful neuroses, and in gynecological

work. The static induced current will produce muscular contractions after both faradic and galvanic currents fail. The sensation of the static induced current is a sensation very similar to that from a faradic battery. It relieves local congestions and local pain, and increases secretion; it also produces muscular contraction and local vibratory effect.

The static induced current is the original high frequency current described under "high frequency." In using the static induced current we should not forget to remove the ground connection. By studying the diagram, no trouble will be experienced in using this form of static current. Dr. Morton advises the use of *small* Leyden jars. Connect the wires to the external armatures. A rapid flow of sparks will pass between the prime conductors at the space S, G (see diagram, Fig. 43).

#### THE METHOD OF EMPLOYING THE STATIC INDUCED CURRENT.

The Leyden jars (preferably the small jars) are used in this form of treatment. Insulated wires are attached to the outer coating of the Leyden jars; sponge-covered electrodes are attached to the other end of these wires and one electrode is placed in each hand of the patient. The patient need *not* be on an insulated platform in receiving this treatment. The prime conductors should be in contact before the machine is started. This is very important, as the current increases in strength very rapidly when the prime conductors are separated suddenly. We should now start the machine (the prime conductors being in contact as directed), and very slowly separate the prime conductors until the patient receives the proper strength of current. Morton's pistol electrode may be used and thus the operator be spared the inconvenience of constantly shifting the prime conductors during the treatment.

The *high frequency* current is sometimes obtained from the static machine; the *positive pole* being grounded, the *negative* should be connected with a resonator to which is attached a glass vacuum electrode. Leyden jars are used to obtain the high frequency currents.

**The Single Spray.**—In giving the single spray we remove the Leyden jars and connect the patient by means of the electrode under the feet, with either the *positive* or *negative* pole; we now separate the prime conductors so that no sparks are seen. We now connect a one-point electrode to the pole, which has *not* been connected to the patient, and hold this electrode at a distance of one foot from the patient's body. The time required for treatment is from eight to ten minutes.

**The Multiple Spray.**—In employing the multiple spray we use an electrode having a number of points, instead of the single-point electrode, and proceed as above. The time required for this treatment is fifteen minutes.

The single and also the multiple spray are employed to relieve local congestion, to lessen local swelling and to diminish local pain.

**The Direct Spark.**—In administering the direct spark the Leyden jars are used. One electrode from the top of one jar is connected with the patient, while the other jar is connected with a ball electrode. We now separate the prime conductors about one-half foot. We hold the ball electrode close enough to the patient's body to cause a spark to jump across. This is a painful treatment and is used in making a marked impression on paralyzed muscles.

**The Induced Spark.**—This form of treatment is used to produce counterirritation, and is employed in the same manner as is the *direct* spark, except that the jars are *not* used. It is not so painful as is the direct spark.

**Roller Massage.**—Roller massage is given *with* the Leyden jars to produce stimulation of and counterirritation to cold extremities, and *without* the jars for ordinary massage. The latter method is the milder.

We must connect the patient to the top of one jar by means of one electrode; then connect the other jar to a roller electrode; the prime conductors must be actually touching *at first*; later we must separate them very carefully to overcome the resistance of the patient's clothing. We should always apply roller massage *through* the *clothing* and *not* on the bare skin, and we should keep the roller moving continually. It is well, always, to warn

the patient as to what may be expected when giving spark applications.

**The Pencil Discharge, or New Spray.**—In this method we place the patient on the platform; we *ground* the *positive* pole if we wish the patient to receive a *negative discharge*; we attach the patient by means of a shepherd's crook to the *negative* prime conductor; we attach a chain for the *second grounding* to a water or gas pipe; and connect the other end of this chain to a wooden electrode with a metallic point or ball. We should now start the machine and, holding the wooden electrode in our hand, gradually approach the patient. The Leyden jars are *not* used in giving this treatment.

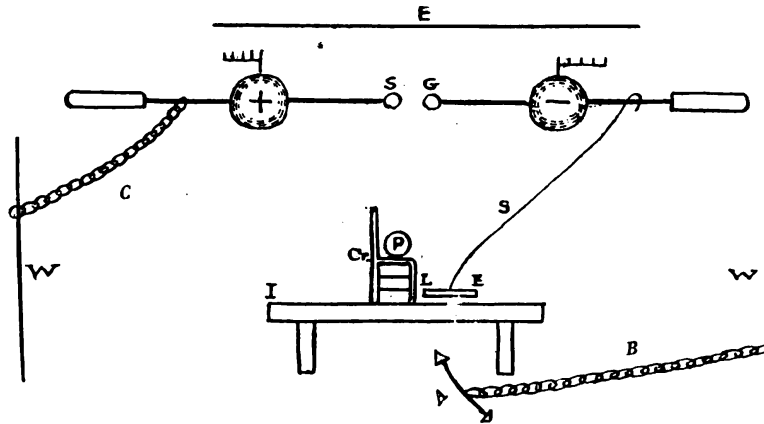

Fig. 44.—The pencil discharge or new spray.

A, Wooden electrode connected with B, a chain which is grounded on W (water pipe). C, Chain from positive prime conductor to water pipe W. I, Insulated platform upon which sits patient (P). L-E, A large metal electrode placed under patient's feet. This electrode is connected by means of S (a shepherd's crook) to the negative pole. E, Source of electricity. S-G, Spark gap. Ch, Chair.

All that need be said of the above-described method of treatment, known as the "pencil discharge," is that it is a very clever imitation of the well-known Morton wave-current. It is readily understood that in the pencil discharge we have the simplest way of obtaining a powerful, high-potential pencil or stream for "fulguration." If we must give the pencil discharge a name, we should call it "indirect spark derived from the wave-current."

## CHAPTER IV.

### FARADIC AND MAGNETIC ELECTRICITY.

---

BEFORE discussing in detail faradic electricity it is advisable to consider briefly magnetic electricity. Magnets are classified as follows:—

1. The *natural* magnet, known also as the lodestone.
2. The *permanent* magnet, familiar to every boy, which consists of a piece of hardened steel. It retains its magnetism for a long time after having been magnetized.
3. The *electro-magnet*, which consists of a core of very soft iron surrounded by a coil of insulated wire. In this form, the magnetism is induced by passing a current of electricity through the insulated coil of wire.

The first two forms of magnets retain their magnetism; not so, however, with the third—the electro-magnet—which gains and loses its magnetism accordingly as the current of electricity passes or ceases.

#### FARADIC ELECTRICITY.

The faradic—formerly and very properly termed the faradaic current, in commemoration of Faraday who discovered this form of current—is the induced, interrupted or extra current. Faraday discovered this very useful form of current in the year 1831; his work appeared in 1847. The faradic battery is now manufactured under so many disguises that even Faraday might find difficulty in recognizing his original ideas.

Duchenne, of Boulogne, through his investigations, discovered the physiologic and the therapeutic properties of the faradic current and placed faradism on a scientific basis; he taught us practically all we know to-day of the current. Duchenne, however, although discovering the difference in strength between the current from the primary and that from

the secondary coils, was never able to explain the difference. This difference is due to the *quality*, the *thickness* and the *length* of the wire in the coil and *not* to the difference in *direction* or *induction*. Faraday was not aware of this fact.

To the discoveries of Faraday and to the invention of the induction coil of Ruhmkorff, we owe the discovery of the fact that an induced current of electricity is generated in a closed wire circuit placed *near to* but *not in contact with* another circuit through which a current is passing.

The faradic or induction battery may briefly be described as a battery consisting of one or more cells placed in circuit with a primary insulated wire surrounding the core; there is an automatic device for alternately breaking and making the current from the cell. Over this primary coil there is slipped a bobbin wound with another coil of insulated wire. This bobbin with the wire is known as the secondary coil; it has no connection with the cell and derives its current by induction by means of its proximity to the primary coil of wire. The different parts of a faradic battery will be described in detail farther on in this work.

#### THE EFFECTS OF THE FARADIC CURRENT.

The faradic current has physical effects similar to the galvanic current, but it has not the electrolytic power of galvanism, nor has it the power of producing osmosis as has the galvanic current. If we test the faradic current for polarity by means of moistened litmus paper, we will obtain neither an acid nor an alkaline reaction. This is readily comprehensible if we but remember that the pole which is *acid* at one moment is *alkaline* at the next, thus causing a neutralization. Nevertheless, the cathode or negative pole may be recognized by applying each pole separately on the tongue during the passage of a weak current; the cathode gives a sharper impression and also has a greater effect on both motor and sensory nerves. Although the current from the faradic battery is to-and-fro in its direction, the existence of an anode—or positive—and a cathode—or negative—pole must in practice be admitted.

The induced current will produce a tingling sensation which



finally becomes a numbness if the current be made stronger. It will cause quick contractions, which become continuous or tetanic, if applied to a healthy muscle or nerve.

The faradic current is also known as the induced, interrupted or extra current.

A short wire secondary gives us a current of low electromotive force but of large quantity. It is used in the treatment of deep-seated muscles, because this form of current is not readily diffused through the tissues.

A long wire secondary produces a current of high electromotive force but of small quantity. It is readily and easily diffused and so is used for treating superficial muscles.

The current from the primary coil is strong, but has a low resistance; it results directly from the chemical action in the cell. Its effects on the body are very different from the effects of the current from the secondary coil. Muscular contractions are produced better with the *primary* current, while, for quieting pain, the secondary is much to be preferred. We should remember that the cell which originates the current is connected to the primary coil only; and that the secondary current is an *induced* current in the coil of fine wire and is a to-and-fro one. The primary coil is feebly *galvanic*, but the secondary is not. As an instance of this we may mention the fact that in ovarian pain the patient obtains relief oftentimes from an application of the secondary current while the primary cannot be tolerated.

The faradic current, because of the magnetization and demagnetization, resembles in a manner static oscillations. The effects of the faradic current are more mechanical than medicinal. The faradic current is a general tonic, and assists in the elimination of the waste products.

When a galvanic current passes through one of two parallel conductors there will be found in the other a current of electricity which flows in an *opposite* direction when the galvanic current is made, but in the *same* direction when the galvanic current is broken. It matters not if, instead of parallel conductors, we employ coils of insulated wire arranged one within the other; we obtain the same induced current from the coils of wire as from the parallel conductors.

### MODES OF ACTION OF THE FARADIC CURRENT.

*Direct* muscular contraction is produced by placing an electrode upon the muscle itself; *indirect* contraction by stimulation of the nerve which controls the muscle. The point at which the nerve enters the muscle is termed the *motor point* or, as Duchenne called it, the "point d'élection."

We should remember that the faradic current has an electric flow, as has the galvanic and the static currents. It occupies a place between the galvanic and the static. It has higher ampèrage but less voltage than has the static and less ampèrage than the galvanic; it is interrupted, induced and variable, resembling somewhat the alternating current.

The principal points of difference between the current which passes through the primary (which is a coarse wire and has low electro-motive force) and the current from the secondary (which is a fine wire and has high electro-motive force) have been given by Duchenne as follows:—

1. The primary current affects organs more or less deeply situated under the skin; it also affects them more intensely.
2. If moist electrodes are employed on the skin, the secondary current penetrates more deeply than does the primary.
3. The secondary current affects the sensibility of the skin more intensely.
4. The secondary current produces more marked reflex contractions.
5. If we apply moist electrodes to the face or to the eyeball, the secondary current acts more intensely on the retina than does the primary.

*Interruptions.*—If we desire to produce sedative effects upon the sensory nerves, we should employ very rapid interruptions, *e.g.*, twenty thousand to forty thousand interruptions per minute; if we wish muscular contractions only, we should use interruptions of from ten to two hundred and fifty per minute.

### THE GALVANIC INDUCING FORCE.

In the production of faradic electricity we employ galvanic currents of small quantity and low tension, the highest ampèrage furnishing the lowest voltage. The Leclanché cells have low ampèrage but high voltage.

The most commonly employed current-producers are:—

1. The sulphate of the binoxide of mercury cell. The receiver or cup in which the salt is dissolved in a little water is made of carbon. After stirring the dissolved salt we place the zinc in it.

2. The small cell of bichromate of potassium.

3. A couple of Leclanché cells. In this form of cell the ammonium muriate needs the addition of water but twice in a year provided we use a well-fitting cover to prevent evaporation.

The current is produced as soon as the circuit is completed; by turning a switch the apparatus is set in motion.

### THE PRIMARY CIRCUIT.

The coil or hollow spiral is termed a solenoid. When traversed by a current of electricity it has all of the properties of a magnet. If a rod of iron be inserted in the solenoid, it becomes an electro-magnet, and all of its properties are intensified.

The primary circuit is always stationary and is a solenoid consisting of a number of turns of well-insulated copper wire. The wire is wound in regular layers upon a hollow cylinder of wood or hard rubber, the zinc connection being inside of the coil. The wire should have the following requisites:—

1. It should not be too thick, so as not to occupy too much space.

2. It must allow sufficient electro-motive force to urge the current through a long secondary coil.

3. It must offer as little resistance as possible to the primary galvanic flow.

4. It must be proportionate to the battery force used. The instrument may be made bulky and its power decreased by using too many windings.

### THE CORE.

The magnetic force of the solenoid depends upon the core which is inside of the solenoid, *i.e.*, upon its conductivity and the rapidity of magnetization and demagnetization. The physiologic effect of the current depends upon the change of potential and the rapidity of variation. The core may be a spiral of wire, a cylinder of soft iron, or a cylinder of copper or brass. The core may be fixed or movable; in some batteries it may be partially or wholly removable. The cylinder of copper or brass known as Duchenne's tube, is made to slide between the core and the primary coil in a pocket-battery, or between the primary and secondary coils if used in the apparatus termed a sledge instrument. In some batteries this tube of Duchenne is withdrawn to increase the current strength, while in others the tube has to be pushed in to increase the strength.

### THE INTERRUPTER.

The interrupter is an automatic arrangement for producing changes of potential in the galvanic current; these changes are produced automatically, without manual interference, by a closing and opening of the primary current. The interrupter is known under various names, such as the hammer, vibrator, trembler, interrupter or current-breaker. The interrupter is one of the most important parts of a faradic battery since, by means of the interrupter, the physiologic effect of the induced current is controlled. Interrupters are usually made to vibrate from 1800 to 3000 times per minute. We have to-day on the market an instrument known as a rheotome which will produce very slow or very rapid interruption of any of the following currents: galvanic, faradic, galvano-faradic, or sinusoidal. Interrupters may be of different kinds. In some the battery current serves as an inducing force and fixes the magnetization and demagnetization which cause the vibration.

First, we have interrupters in which the core itself acts as the attracting magnet.

Secondly, the interrupters in which a separate magnet is formed.

Third, the batteries in which the interrupter is separate and distinct from the induction apparatus and receives an independent motive force.

Fourth, the single-impulse key.

Fifth, the rapid controllable interrupter.

In some of the larger instruments of foreign make a small electro-magnet wholly independent of the core furnishes the attracting force.

#### THE SECONDARY CIRCUIT.

The induced current as used in medicine is taken from the secondary circuit. We increase its force as we do the force of the primary circuit by increasing the number of windings each winding having the same electro-motive force. The less the resistance the greater will be the quantity of electricity. We

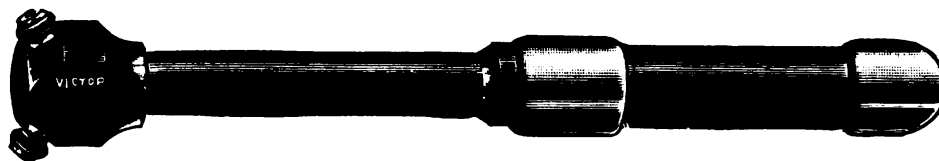

Fig. 45.—Victor bi-polar electrode.

should remember that the thicker the conducting wire and the shorter it is the less resistance will be offered. The secondary circuit, like the primary, is made of well-insulated copper wire wound on a non-conducting hollow reel. This reel should be as thin as possible as the nearer the inducing and secondary currents are to each other without touching, the stronger the induced current will be.

#### THE INTENSITY OF PHYSIOLOGIC EFFECT.

It is very important to have on our faradic apparatus some method of controlling the current strength without altering the primary galvanic current, although some makers entirely ignore this important fact. A withdrawal or an insertion of the core or of the shield will increase or decrease the strength of the primary or direct current according to the make of instrument.

In some instruments the primary coil and the core are immovable, while the secondary coil slides over them. This is by far the better method of varying the strength of the current. Whatever instrument is employed we should have an apparatus that will allow a gradual and regular increase of current.



Fig. 46.—Victor bi-polar intra-uterine electrode.

### FORMS OF FARADIC BATTERIES.

There are (1) the pocket battery; (2) the portable or box battery; and (3) the stationary or sledge battery. It is an admitted fact that the large faradic instruments now manufactured in this country far surpass those made in foreign countries.

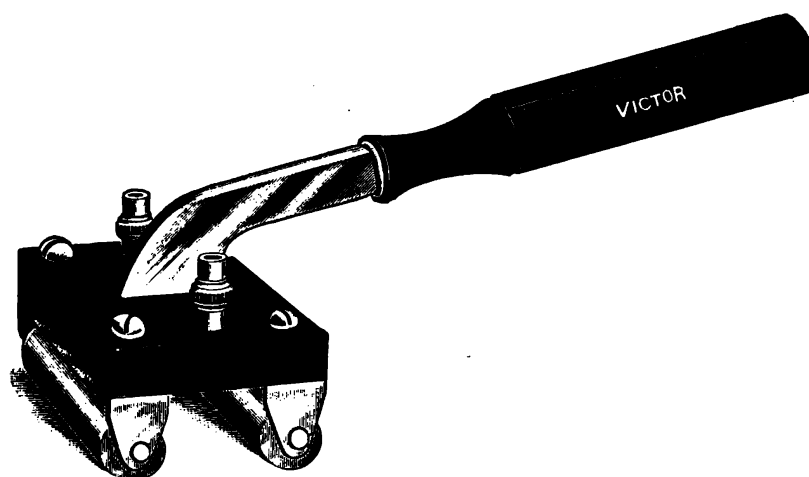

Fig. 47.—Victor bi-polar massage electrode.

### THE ELECTRODES.

Different forms of electrodes are used with faradic batteries. Some of them are single, and some bi-polar; the shape and size of the electrodes depend entirely on the part to which they are to be applied and the purpose for which they are to be used. Apostoli introduced a bi-polar intra-uterine electrode.



Fig. 48.—Victor No. 2 portable faradic.

Tripier devised a bi-polar rectal electrode. Bergognie invented a bi-polar rectal electrode with a manometer which enables us to study the contractile power of the sphincter muscles. For

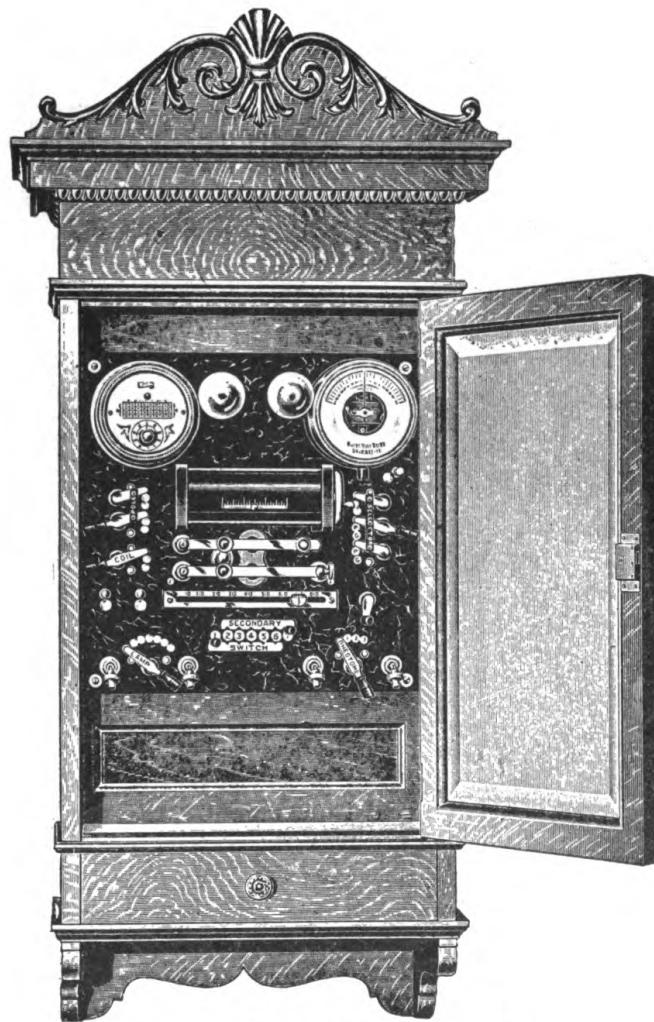

Fig. 49.—Victor high tension plate.

faradic massage we have the plate electrode of Mordhurst, the roller rheophore of Piffard, and the wristlet electrode. The electrodes employed for administering the faradic bath are large plates covered with an air-cushion, or some non-conducting material, to prevent the electrodes touching the body.



### THE SELECTION OF A FARADIC BATTERY.

Only a short time ago it was stated in a learned body of electricians that the small box battery will furnish all of the faradic electricity needed in medicine. Some text-books state that the choice of a faradic battery is of but small importance,



Fig. 50.—Victor No. 3 combined outfit (portable).

and that the construction and mechanism may well be entrusted to the maker of the battery. As a matter of fact, it is more important to exercise good judgment in the selection of a faradic battery than it is in the choice of the galvanic. The character and efficiency of the faradic current depend entirely

upon the construction and the mechanism of the apparatus. Every physician realizes that we get exactly the same galvanic current from a beautiful wall cabinet as we obtain from the old Leclanché cells. This is not true of different makes of faradic apparatus.

The things which influence the faradic current are: the nature of the core and its dimensions; the number and character of the interruptions; the length and thickness of the wire; and the gradation of current-strength by the sliding of the secondary coil over the primary.

There is no doubt that physicians have been gradually weaned from the faradic current and have almost entirely forgotten the many uses of this very pliable form of electricity. We should remember that we can produce artificial respiration more quickly and better by means of the faradic current than we can in any other way when we have to deal with cases of drowning, asphyxia, opium poisoning and shock from accidental contact with a heavily laden electric wire. It is especially useful in the resuscitation of the new-born. Interruptions of about 20 per minute should be used.

Faradic electricity is the field most given over to quackery. It is astonishing how a patient is impressed by the sensations produced by a faradic current and by the buzzing sound. It is remarkable the number of small faradic batteries sold at a low price to the laity who use them, irrespective of the indications present in a given case.

#### USE OF THE FARADIC CURRENT IN DIAGNOSIS.

The faradic current is used to determine the existence of pathological excitability and to determine whether a lesion is peripheral or central, and further to detect simulation. We are also able to determine certain conditions, *e.g.*, to differentiate between nervous and hysterical pains of the ovary and those which are inflammatory. Apostoli recently elaborated this method, which should be more frequently used, as many a patient has been subjected to an operation for ovarian pain of a purely hysterical nature. Not only may such a pain be

detected by the faradic current but also be relieved by it. A careful faradic examination will frequently prevent unnecessary surgery.

Suppose we are in doubt whether we are treating a case of simple ovaritis or a case of pyosalpinx, how will we be aided by electricity? If we use the galvanic current with one electrode within the pelvis, we will cause pain; if now the rapidly interrupted secondary faradic current be used, and the pain relieved, we may be certain that pyosalpinx is *not* present. If, on the other hand, the pain is *not* relieved by the faradic current, we may advise an operation and feel sure that the gynecologist will find pus when he operates.

We should always use the *faradic* current for any pain that is relieved by pressure. We should *never* use the *faradic* current in a pain which is made worse by pressure. In this instance we should employ the *positive* galvanic, the static, the sinusoidal, or the high frequency currents, any one of which may relieve pain due to, or made worse by pressure.

In a given case of paralysis we are often in doubt whether the lesion emanates from the brain or from the motor cells of the spinal cord. In such a dilemma we employ the *faradic* current with an automatic rheotome; a large indifferent electrode is placed on the sternum and a small electrode at the motor point of some muscle on the *normal* side; we now employ sufficient current to get a noticeable contraction. Leaving the indifferent electrode still on the sternum, we place the small electrode at the motor point of the corresponding muscle of the supposedly paralyzed limb and note if the contraction is normal, decreased, or increased; if increased, the lesion is in the brain or upper motor tract. We will also find exaggerated reflexes under these circumstances. If the contraction to the faradic current be decreased the lesion is in the motor cells of the spinal cord or in some other part of the lower motor segment. This will explain a fact well-known to neurologists that we often see exaggerated reflexes and great irritability of muscles in palsies of *cerebral* origin. We should remember that the nutrition of the muscles is directly interfered with only when the lesion is in the lower motor segment. If the lesion be

in the upper motor segment the nutrition of the muscle will not be affected, as the nutrition in this case will be maintained by the centers in the cord.

We should remember that in hysterical paralysis we usually have an anesthesia so we also find a decreased sensibility to the faradic current but a normal contractility. In infantile paralysis we find faradic contractility has disappeared, while voluntary contractility is increased.

It matters not how muscles are severed from their centres—whether by neuroma, neuritis, compression, contusion, or section—the same result will follow an irreparable injury, viz.: muscular atrophy following degeneration of the nerve.

Every electro-therapeutist knows that often more skill is required in electro-diagnosis than is requisite in the treatment of the disease after the proper diagnosis has been made. As is well-known, we find at times an entire absence of response to the strongest faradic currents when we examine motor nerves and muscles. In such cases we must resort to the galvanic current, using a milliampèremeter to give accuracy to our examination. Unfortunately the electro-diagnostic examination is too little known and used by physicians. We may be called upon, as before explained, to tell our patient whether he is suffering from a very trifling palsy or a palsy which is cerebral in origin.

#### APPLICATION OF THE FARADIC CURRENT.

The faradic current may be used in medicine in the following ways:—

- (1) By means of the direct application of the current.
- (2) As faradic massage.
- (3) As the faradic bath.

(1) The direct application is given by having both poles in contact with the body, as (*a*) *general faradization*, (*b*) localized or polar, and (*c*) bi-polar faradization.

General faradization is given as a labile application, applied over the whole body, and is used as a general tonic and stimulant; it is especially useful in cases of poisoning, drowning and asphyxia.

Localized or polar faradization is given by applying one pole direct to the part affected. This application may be labile or stabile, accordingly as we move one electrode over the surface or hold both electrodes stationary. If we wish to produce a superficial effect, we simply apply a dry metallic electrode to the dry skin; if a deep effect be desired, we apply well-wetted electrodes. We should remember that the short coil of *fine* wire is the more powerful irritant if the dry electrode be used; the *short* coil of *heavy* wire gives better *muscular* contractions; the *long* coil of *fine* wire will have, if very rapid interruptions are used, the greater *sedative* effect.

The bi-polar method is given by having both poles contained in one electrode. Apostoli has given a great impetus to the bi-polar method and claims for it:—

(a) Being so simple no assistant is required.

(b) The sensitive skin being avoided, the application is not so painful.

(c) Because, as it localizes the complete effect of the current on one small part, it is more active.

(d) Because of the lessened sensibility we may use a stronger current; hence, it is a more efficient method.

The bi-polar method is especially efficacious in relieving ovarian and pelvic pains.

(2) Faradic massage is very efficient in the treatment of neurotic women, as in the Weir Mitchell rest treatment, and in aiding in establishing a cure when tonic hydrotherapy is being given. If we are using hot medicated baths and wish to increase their *absorbing* action, we use *galvanic massage*. If, on the other hand, we wish to increase the *sedative* effect of the tonic baths, we use *faradic massage*.

*Galvanic* massage is used in treating *acute articular* rheumatism, while *faradic* massage is used in neuralgias, headaches, constipation, *muscular* rheumatism, and in *chronic articular* rheumatism.

In giving faradic massage we use a roller massage electrode and the current from an ordinary faradic battery.

(3) The *faradic bath* is of course the ideal method of giving general faradization and is used as an excellent stimulant

in anemia, neurasthemia, or in any form of general debility. This bath is given in the following ways:—

(1) A copper bath tub is used, the patient being protected from the sides of the tub by having him rest on a lathwork of wood. One electrode is attached to the tub while the other is placed on some part of the body *out* of the water.

(2) A porcelain or wooden tub is used. The shoulders are allowed to rest on the non-conducting protector—a rubber pillow filled with water—of one plate, while the feet are placed against the other plate.

It is most unfortunate that this really valuable bath is often given by an unskilled and ignorant person, in some public establishment—who gives the bath to any one who pays the price, irrespective of the indication and necessity for this particular treatment. It is high time that the medical profession should awake to the fact that this bath does *not* belong to the domain of the quack.

## CHAPTER V.

### REACTION OF DEGENERATION.

---

It is easy to understand what a remarkable bearing a thorough electrical examination might have in determining true and false claims for damages due to accidents. It would be very easy to convince the court that the plaintiff was, or was not paralyzed, as claimed. The perpetrators of fraudulent claims might very readily be exposed, while rightful claimants would receive justice.

If we use the slowly increasing faradic current, have a large indifferent electrode, and test a healthy muscle or motor nerve we will find that the active negative pole will give the stronger response. This will be more noticeable if we at once test the corresponding muscle on the opposite side of the body. If we use a galvanic current, the above statements will be true if the muscle or motor nerve be healthy, that is—we will have the cathodal closing contraction greater than the anodal closing contraction, if we test a healthy muscle or motor nerve with the galvanic current.

In testing motor nerves and muscles, it is important to have a systematic method. We should have the indifferent electrode as large as possible and apply this electrode upon some point where the nerves are few, so as to cause as little discomfort as possible to the patient. The points usually selected are the sternum, the back of the neck, or the small of the back. We should have the active electrode very small so that we may condense the current. Sometimes the electrodes are placed near each other as, for example, in testing the small muscles of the feet and hands. We should have the electrodes well wetted with plain water and apply them on the skin. Sometimes a saline solution is used, but this may act on the electrodes. It is important that the electrodes be properly placed.

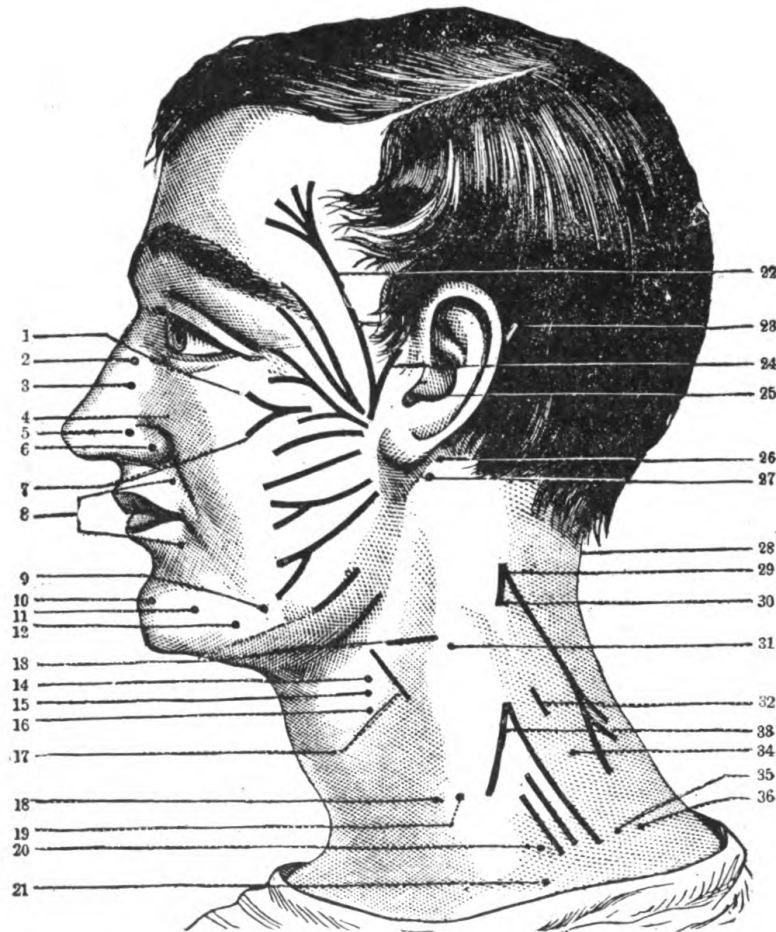

Fig. 51.—Diagram of the motor points of the face. (Ranney.)

Showing the position of the electrodes during electrization of special muscles and nerves. The anode is supposed to be placed in the mastoid fossa, and the cathode upon the part indicated in the diagram.

1, m. orbicularis palpebrarum; 2, m. pyramidalis nasi; 3, m. lev. lab. sup. et nasi; 4, m. lev. lab. sup. propr.; 5, 6, m. dilator naris; 7, m. zygomatic major; 8, m. orbicularis oris; 9, n. branch for levator menti; 10, m. levator menti; 11, m. quadratus menti; 12, m. triangularis menti; 13, nerves, subcutaneous, of neck; 14, m. sterno-hyoid; 15, m. omo-hyoid; 16, m. sterno-thyroid; 17, n. branch for platysma; 18, m. sterno-hyoid; 19, m. omo-hyoid; 20, 21, nerves to pectoral muscles; 22, m. occipito-frontalis (ant. belly); 23, m. occipito-frontalis (post. belly); 24, m. retrahens and attollens aurem; 25, nerve—facial; 26, m. stylo-hyoid; 27, m. digastric; 28, m. splenius capitis; 29, nerve—external branch of spinal accessory; 30, m. sterno-mastoid; 31, m. sterno-mastoid; 32, m. levator anguli scapulæ; 33, nerve—phrenic; 34, nerve—posterior thoracic; 35, m. serratus magnus; 36, nerves of the axillary space. In this text m. = muscle; n. = nerve.



It has been found that, when an electrode is placed at or near a certain point on any muscle we may produce a contraction with less current. Such a point is known as a motor point of Erb. It is found to be the point at which the motor nerve enters its muscle. Diagrams are made which show on the human body where these points are.

#### METHOD OF TESTING FOR REACTION OF DEGENERATION.

1. We should apply the current to our own body, using the induction coil, to convince our patient that there is no danger. We should remember that nearly everyone has more or less dread of electricity; this is important when treating a timid patient.

2. We should have the patient relaxed. Our electrodes well wetted and applied as described. We should use the negative as the active electrode and turn on just enough current from the induction coil to produce the smallest noticeable contraction. If we get no contraction, we should increase the strength of current; but we should remember that, in some cases of nervous trouble, we may get no faradic response. If we increase the current until it becomes painful and still obtain no contraction, we note the fact that there is no faradic response.

3. Now, by using the galvanic current, we try first for the Ca. Cl. C. and then, by reversing the polarity without changing the electrodes, we test for the An. Cl. C. If we have a milli-ampèremeter, we should record the strength of current requisite in each case. The Ca. Cl. C. is greater than the An. Cl. C. in normal cases, *i.e.*, the same current strength will produce a stronger contraction at the Ca. Cl. C. than at the An. Cl. C., so we express this as Ca. Cl. C., > An. Cl. C., reading that the Ca. Cl. C. is greater than the An. Cl. C.

We should observe the kind of contraction produced, whether quick, sluggish or tetanoid.

4. Now in the same manner we perform the same tests on the corresponding muscles of the healthy side and note the strength of current used and also the kind and nature of the contraction.

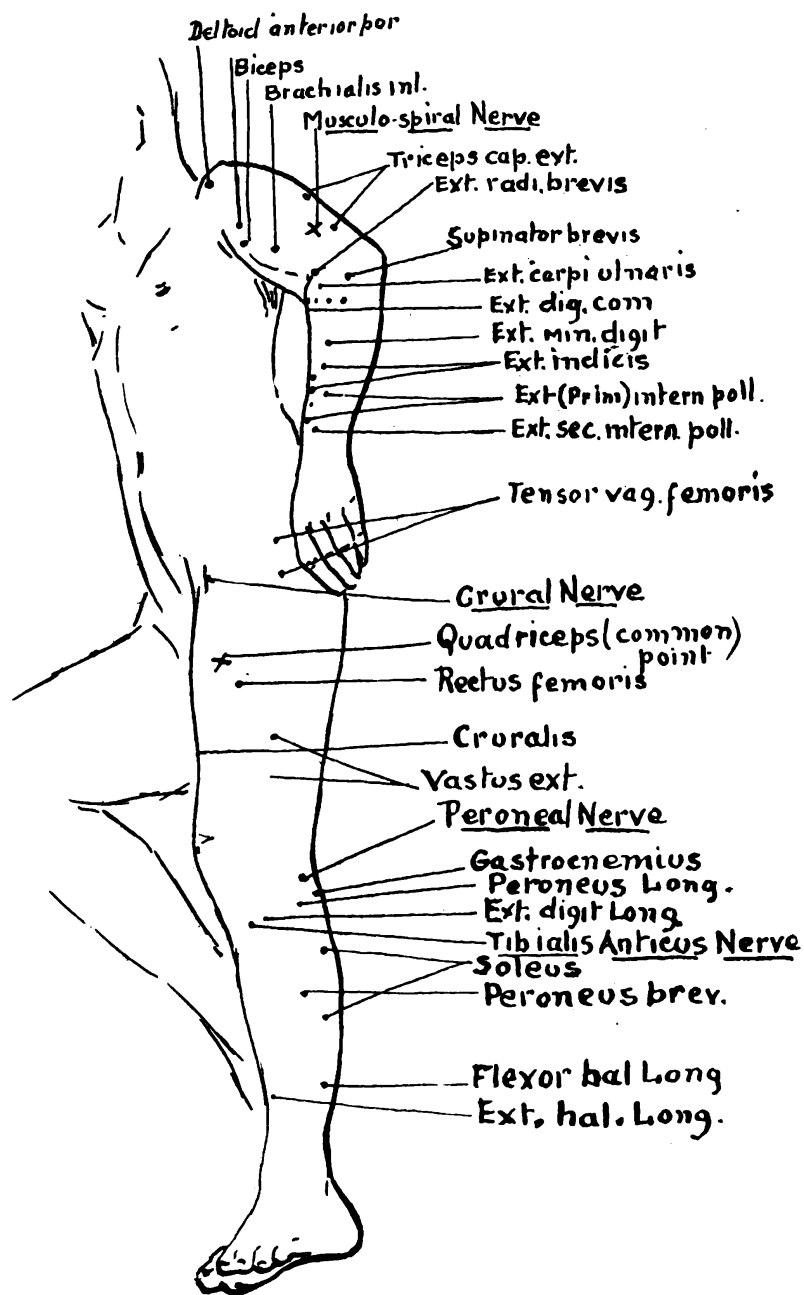

Fig. 52.—Diagram of motor points.

Normal Reaction (with the galvanic current)—

For Nerve—Ca. Cl. C. > An. O. C. > An. Cl. C.

For Muscle—Ca. Cl. C. > An. Cl. C. > An. O. C.

It will be seen, from this, that in the case of a normal *nerve* the An. O. C. is greater than the An. Cl. C.; in the case of a normal *muscle* the An. Cl. C. is greater than the An. O. C. The cathodal opening contraction is not sought as this would require a too painful strength of current.

Sometimes it is well for the operator to place the active electrode on the back of his own hand and then to pass the current through his hand into the patient's body. This method is very reassuring to a timid patient and also enables the physician to gauge in a measure the strength of current. If using the street current, we start with two or three milliampères if testing about the face, and about eight milliampères on the body.

We should explain to timid patients that here is absolutely no danger, as the current first traverses the body of the operator. In making these electrical tests the active electrode should have a key that may be opened or closed, so as to elicit the opening and closing contractions with convenience. We should compare direct stimulation of the muscle with the contraction produced by the stimulation of its motor nerve. The test should be made with the induction coil current, using the bare metal electrode or the wire brush, and the skin should be dry.

If we are using a portable galvanic battery, we should use about fifteen cells on the body and about seven cells on the face. We should use the meter if we have one, using three milliampères on the face and eight milliampères on the body. The indifferent electrode should be about twenty times the size of the active one, which is the cathode or negative.

Now, that we have noted what happens to healthy muscles, let us see what may be found if we have degeneration of nerve and muscle. Here the changes are of two kinds: quantitative and qualitative.

' *Quantitative* changes mean either an increase or a decrease of excitability. Decreased excitability is often seen and may mean very little. It is seen, at times, in simple fatigue, and also in mild cases of neuritis and in anterior poliomyelitis.

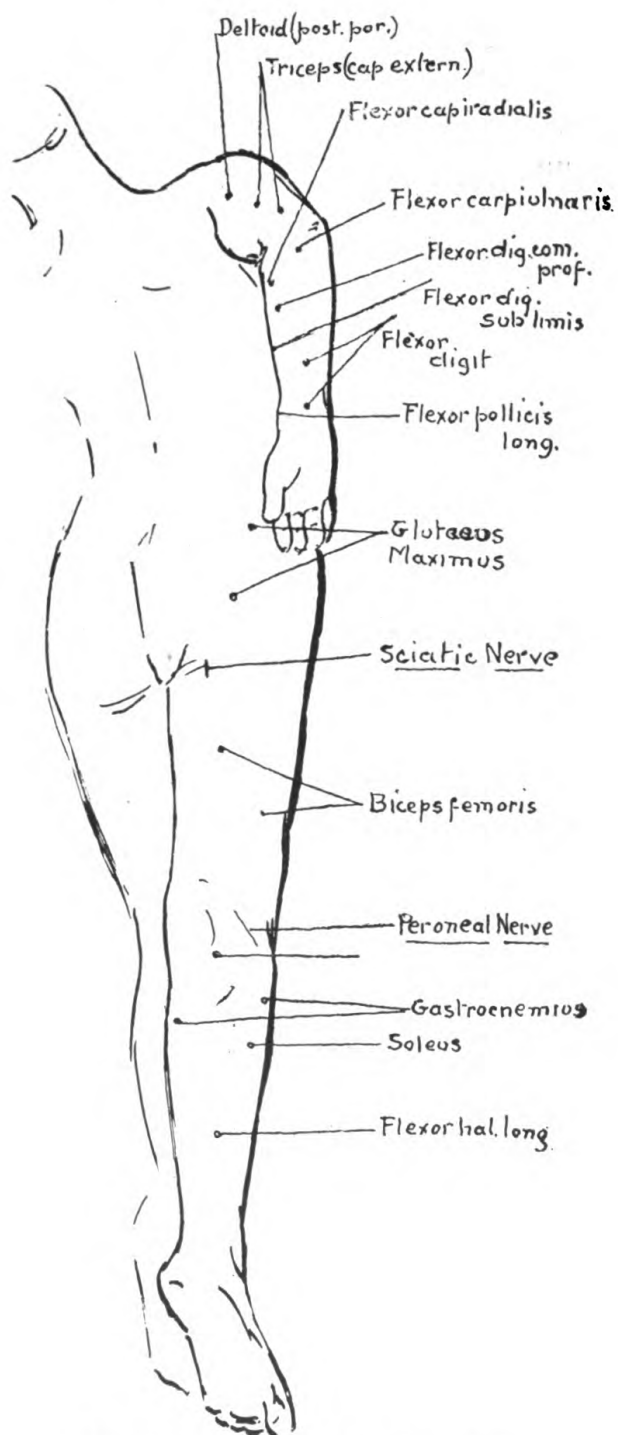

Fig. 53.—Diagram of motor points.

We sometimes find that the skin of a paralyzed limb has a higher resistance and thus causes decreased excitability. Increased excitability usually means increased reflexes and so an increased irritability in the central nervous system. It is found in unilateral disease of the cord, in chronic myelitis, in degeneration of the lateral columns, in hemiplegia, and in tetany.

*Qualitative* changes are always of great importance, for they mean reaction of degeneration.

We recognize qualitative changes by the fact that the muscles respond by a slow and sluggish contraction instead of by the sharp, quick jerk seen in health, and by the fact that the anodal closure contraction is more pronounced than it is in health. It may become equal to, or greater than the cathodal closure contraction. A slow sluggish contraction may be just as positive evidence of reaction of degeneration as is the fact of An. Cl. C. being greater than Ca. Cl. C. It is well to remember the definition of reaction of degeneration as given by Erb, who states it thus: "The reaction of degeneration is characterized by the diminution and loss of the faradic excitability in both nerves and muscles, whilst the galvanic excitability of muscles remains unimpaired, is sometimes notably increased, and always undergoes definite qualitative modifications."

In the early stage of reaction of degeneration we often find an increased excitability. In established reaction of degeneration we find that the muscle will not respond if the motor nerve be stimulated, nor will the muscle respond if direct stimulation with the faradic current be employed. Reaction of degeneration may be written Re. D. or simply R. D.

It is best to use, as already pointed out, an interrupter on the active electrode. Sometimes it is well to place a finger lightly over a tendon in order to notice the contraction when it is slight. We should use the interrupting handle for both faradic and galvanic currents. The active electrode should be made the negative when using galvanism and we should elicit the Ca. Cl. C. first; then we should at once reverse the polarity and the An. Cl. C. should be elicited.

The cathodal closing contraction is expressed as Ca. Cl. C. The anodal closing contraction as An. Cl. C.

In testing for R. D. the part should be relaxed and the skin well moistened to decrease resistance.

The electrodes should be well wetted with plain warm water. Some operators use a solution of sodium chloride or of sodium carbonate. While these solutions may be used, we should not forget that they have an action on the electrodes. We should not use strong currents for either the faradic or the galvanic current, and should always use the milliampèremeter for galvanic currents, when possible.

We know that normally there is a link connecting the end plate of the muscle with the nucleus of origin in the cord. When R. D. is present we have a break in this link. From this it is obvious that any disease or injury of the motor nerve trunks, of the cells in the anterior cornua of the spinal cord, or of those of the nuclei of the cranial motor nerves will show R. D. We do not find R. D. in disease of the muscle fibres themselves, as, for example, in idiopathic muscular atrophy, nor in paralysis of cerebral origin. When R. D. is coming on we first note a short period during which there is an increased excitability of the nerve. This is quickly followed by a decrease, so that in any case of complete motor nerve section the nerve loses its irritability to both faradic and galvanic currents; this occurs in about two weeks. In muscles we see the same increase and then decrease of irritability to faradic and galvanic currents, except that the galvanic irritability may not be lost for two months. Sometimes it is well to place the active electrode on the tendon of the muscle, as when degeneration of the intramuscular nerve fibres has taken place. Longitudinal reaction is often required in severe cases of R. D.; this method consists of placing the electrodes at each end of the muscle.

We should bear in mind that even when total faradic and galvanic extinction are present the muscles may even yet recover. In such a case a return of voluntary movement may be observed before any improvement is shown by the electrical tests. Sometimes we will note a slight return of faradic excitability, while the galvanic is still sluggish. We speak of this as partial R. D. If partial R. D. be present in a given case what does it mean? It means that we have a case which is going on to complete

R. D.—unless recovery or arrest supervenes, or that R. D. has been present and that the muscle and nerve are now returning to normal.

It is only when the lower segment of the nervous system is involved that R. D. is elicited. R. D. is *not* found in *cerebral* diseases, whether functional or organic. This may be readily understood if we only remember that the nutrition of the muscle or nerve is not interfered with by cerebral lesions. R. D. is not found in locomotor ataxia, lateral sclerosis, or in disseminated sclerosis provided that in the latter the white substance of the cord only is involved. R. D. is not found in palsies of peripheral origin where they are only transitory and due to slight pressure. R. D. is not found in a paraplegia, due to a transverse lesion of the cord, in those muscles and nerves supplied by parts of the cord above and below the seat of injury. However, the nerves and muscles supplied by the diseased portion of the cord will show R. D.

It is known that the peripheral nerves do not degenerate unless there are lesions of the lower motor neurone. So, if we find that the muscles retain the faradic contractility together with a normal galvanic reaction we may be sure that there is no disease of the anterior horns and roots or the peripheral nerves. We cannot, however, be certain that there may not be extensive disease of the central (higher) nervous system. If R. D. be found we may exclude disease of the brain, functional paralysis, primary affections of the muscles (dystrophies)—although R. D. may be found very late in the disease in the dystrophies. With R. D. present we may feel certain that we have to do with disease of the anterior horns and roots or the peripheral nerves.

Let us now briefly take up the quantitative changes in muscles and nerves.

Increased galvanic irritability of muscles means early degenerative changes. Increased faradic irritability is seen in tetanus and in hemiplegia with contractures and excitable reflex centres. Diminished irritability of a nerve to both faradic and galvanic currents usually means beginning R. D. which will readily become complete; yet we may see diminished irritability

of both nerve and muscle in pseudo-muscular hypertrophy in cerebral palsies of long standing and in old cases of lateral and posterior sclerosis. In progressive muscular atrophy and in atrophy from wasting diseases or from disuse we also find, at times, a diminished irritability of both nerve and muscle.

We find R. D. in the following conditions:—

(a) In any disease or injury in which there is a break in the nervous link which connects the end plate of the muscle with its nucleus of origin in the gray matter of the anterior cornua of the cord.

(b) In any injury or disease of the trunks of the motor nerves, of the nuclei of the cranial motor nerves, or of the ganglionic cells in the anterior cornua.

(c) In peripheral neuritis.

(d) In acute and chronic anterior poliomyelitis.

(e) In lead palsy.

(f) In diphtheritic palsy.

(g) In bulbar palsy.

(h) In multiple neuritis.

(i) In myelitis if the anterior cornua are involved.

(j) In neuritis of both motor and mixed nerves.

(k) In diseases of the spinal cord if muscular atrophy be present.

Presence or absence of R. D. will aid us in differentiating between a peripheral and a cerebral lesion, as for example in a case of facial palsy.

#### PRACTICAL HINTS IN TESTING FOR R. D.

1. We should first use the faradic and then the galvanic current; we should not use strong currents in either case.

2. The patient's muscles must be well relaxed.

3. The current should be tested on the arm of the operator to reassure the patient; this is especially important in treating nervous women or in treating children.

4. We should have an interrupting handle on the negative electrode, and should first obtain the Ca. Cl. C. The polarity



should be reversed, without changing the electrode, and the An. Cl. C. elicited.

5. We should always use a milliampèremeter and record in milliampères the strength of galvanic current employed.

6. Both electrodes should be well moistened with plain warm water and the large indifferent electrode placed on the sternum or on the back of the neck; the indifferent electrode should be frequently moved about as the patient may complain of pain or of a burning sensation under this electrode.

7. In testing only one side of the body for R. D. we should always test the healthy side of the body also and record our readings on the milliampèremeter; this is for comparison with the readings of the injured side of the body.

8. We should also test with the induction coil, using a *bare* electrode on the dry skin.

9. We should not forget that in mild cases of R. D. we may obtain results at the end of the examination which differ from those obtained at the beginning; this is especially true if the current be used for a long time. This is explained by the fact that long use of the current seems to stimulate the muscles to a slight degree and so may mislead us.

10. We should always note whether the contractions are quick and sharp, or slow and sluggish.

11. We should first stimulate the muscle directly and then stimulate the motor nerve; and record the results.

12. If unable to spare the time to test every muscle as shown by charts of the human body, we should test the four pairs of nerves suggested by Erb, namely, the ulnar, in the groove between the olecranon and the internal condyle; the frontal branch of the facial; the peroneal near the head of the fibula; and the spinal accessory where it pierces the sternocleidomastoid at the top of the supraclavicular triangle.

It is a good plan to apply the electrodes and not to turn on any current for a few moments, especially when treating children and nervous women. These patients will at once expect to receive a shock when the electrodes are placed in position. After waiting a few moments we may turn on the current and gradually increase it.

Some form of chart should be used in making a report of the test for R. D. The following will serve as an illustration:—

Charles Snyder, 360 South Broad street, Philadelphia, Pa.

Case of wrist-drop, right arm. Referred, March 16, 1909. by Dr. C. J. Smith, 1216 Spruce street, Philadelphia.

Case of four weeks' standing.

#### NERVE REACTIONS.

<i>Right Arm</i> (name of nerve tested)		<i>Left Arm</i> (name of nerve tested)
18 m. a. ....	Ca. Cl. C. ....	18 m. a.
14 m. a. ....	An. O. C. ....	20 m. a.
20 m. a. ....	An. Cl. C. ....	22 m. a.
Absent.....	Faradic Contraction.....	Present.

#### MUSCLE REACTIONS.

<i>Right Arm</i> (name of muscle tested)		<i>Left Arm</i> (name of muscle tested)
17 m. a. ....	Ca. Cl. C. ....	16 m. a.
15 m. a. ....	An. Cl. C. ....	19 m. a.
19 m. a. ....	An. O. C. ....	21 m. a.
Absent.....	Faradic Contraction.....	Present.

The findings should be registered in this manner:—

Nerve Reaction (right side)—An. O. C. > Ca. Cl. C. > An. Cl. C.—No. F. C.

Muscle Reaction (right side)—An. Cl. C. > Ca. Cl. C. > An. O. C.—No. F. C.

R. D. present on the right side; no R. D. on the left side.

As an example of the assistance which electrical examinations give in prognosis, it may be stated that in a case of facial palsy which at the end of ten days does not show R. D., recovery will probably take place in about three or four weeks; if partial R. D. be shown at the end of ten days we may predict recovery in a couple of months; if complete R. D. be found we should state that recovery will probably require at least one year.

If a nerve be cut and then sutured, we may predict that there will be required from four to eight months for restoration of the function. In the case of this restoration the muscles nearest the incision will recover before those farther away. We should remember that we will see cases in which voluntary movement returns before we find any improvement in the electrical reactions. However, we should never be so rash as to base our prognosis on R. D. tests alone, for we may be dealing with some incurable disorder.

## CHAPTER VI.

### ELECTROLYSIS.

---

ELECTROLYSIS is a term employed to denote the separating of a substance into its elements by means of the electric current. The substance to be broken up must be a conductor of electricity, a fluid, or a semi-fluid; and one element must be either a metal or the salt of a metal. Fats and oils are non-conductors and therefore cannot be electrolyzed. The elements into which the substance is divided are called *ions*, a term introduced by Faraday. Sodium chloride will break up into sodium and chlorine, under the action of the electric current; zinc sulphate into zinc and  $\text{SO}_4$ . The metals carry positive charges of electricity, while the non-metals, like chlorine, carry negative charges.

The acid element is set free at the positive and the alkaline element at the negative pole. If we place the two poles in water the oxygen will collect at the positive pole while the hydrogen will go to the negative; the water, in this instance, will be separated into the elements, hydrogen and oxygen. In the decomposition of the water a few bubbles of hydrogen will be seen at the positive pole, but the greater number will collect at the negative. In decomposing a solution of iodide of potassium, iodine—the acid element—will be found at the positive pole, while potassium—the alkaline element—will appear at the negative. When using the electrodes for the electrolysis of living tissues a small acid and dry eschar forms under the positive, and a large alkaline and moist slough under the negative electrode.

Faraday termed the body to be decomposed, the electrolyte. The term electrolyte, as here employed, should not be confounded with the same term as previously applied to the battery fluid which is the active agent in producing the electric current; the term, as here used, means passive.

The ions always take a certain direction toward one or the other pole of the battery. The element which goes to the positive or anode is an electro-*negative* element and therefore because it goes to the anode is called the *anion*; while that which goes to the negative pole is the electro-*positive* element and hence is termed the *cation*. The word *ion* is from a Greek root meaning to go. These terms are derived from a supposed analogous relation to the motion of the sun. The anode is supposed to be the place where the current starts or "rises" (*anahodos*, the way up), while the cathode is looked upon as the place where the current rests or "sets" (*kata hodos*, the way down).

Electrolysis is used in the treatment of nevi and tumors and in depilation. Bubbles of gas are produced at each pole; at the positive pole a coagulation takes place and the needle will adhere to the tissues making it difficult of removal. At the negative pole there will be found liquefaction; so this needle may be easily removed. The eschar at the negative, while larger, is more pliable.

A good method of remembering the action of each pole is to recall the fact that the positive pole is at the same time *acid*, *anesthetic* and the *anode*—the three A's, *i.e.*, the Acid, Anesthetic, Anode; the negative of course being the opposite. The positive pole does less destruction to the tissues than does the negative.

It is very important to remember that the positive pole will coagulate fluids, arrest hemorrhage and decrease inflammation; while the negative pole will liquefy tissues, increase hemorrhage and also increase inflammation.

Because of the astringent and coagulating properties of the positive pole we use this pole in the treatment of: Aneurysms, nevi, varicose veins, goitres, in hemorrhages, in excessive granulations and in phagedenic conditions. Sometimes the positive electrode is made of pure zinc, pure copper or of the mercuric amalgams of zinc and copper. Usually gold, platinum or irido-platinum needles are used at the positive pole. A steel needle may leave an indelible mark if used at the positive pole. If we should be so unfortunate as to disregard this fact we will

be forcibly reminded of it if we happen to disfigure the face of a patient.

A strong current for a short time will produce the same effect as a weak current applied for a longer time.

There is no danger of pigmentation of the skin, if a steel needle is used at the negative pole.

Because of the previously named actions of the negative pole we use this pole: To remove superfluous hairs, warts and moles and to soften cicatricial tissue such as is found after burns, scalds and traumatisms.

#### ELECTROLYSIS IN THE TREATMENT OF ANEURYSM.

In treating aneurysm by means of electrolysis we employ silver, gold or platinum wire introduced into the sac. The length of wire will depend, of course, on the size of the sac. After the wire has been introduced into the sac we connect the outer end of the wire to the positive pole. This is done because the positive pole coagulates the blood; the wire furnishes the material around which the blood may clot when the current is turned on. From fifty to sixty milliamperes of current from a galvanic battery or from the street-current are slowly passed into the sac. Sometimes, instead of the wires named, we employ a wire composed of copper 10 per cent. and silver 90 per cent. The advantages of this particular wire are that the wire is rougher and is less likely to kink. The negative pole should, in this case, be placed on an indifferent point and should consist of a large indifferent electrode.

The treatment of aneurysm by means of electricity has been very successful. The best method is to use gold wire, not too long, introduced by means of an aspirating needle of suitable size. We should use a gold wire, and have the length of wire just twice the dimensions of the sac in inches. Of course, the greatest aseptic and antiseptic precautions must be employed. We should not introduce an excessive length of wire as nothing is gained thereby. One hundred feet of wire have actually been so employed. After introducing the wire through the aspirating

needle we should attach the outer end of the wire to the positive pole of a galvanic battery or of the street-current; then we attach the negative pole to a large clay plate and place this plate against the patient's back. A current of fifty milliampères should be employed for ten minutes and the current then gradually reduced to zero. After separating the wire from the positive pole the insulated aspirating needle should be carefully withdrawn from the sac, the wire should be cut off close to the skin, and the end of the wire should be pushed under the skin and into the sac. The puncture should be closed with collodion. Many cases have been cured and others wonderfully improved by this method of treatment.

#### DESCRIPTION OF THE WIRING OF AN ANEURYSM.

The description here given is of a case of aortic aneurysm wired by Professor H. A. Hare, at Jefferson Hospital.

The patient was anesthetized and ten feet of number 28 gold wire, 18 k., were inserted at 11 A.M. and a current of ten milliampères employed; every two minutes the current was increased five milliampères until, when the current-strength of thirty milliampères was reached, the needle was very quiet and pulsation had very much decreased. The current was further increased five milliampères every two minutes until the current-strength was fifty milliampères; this strength of current was continued for ten minutes. The current was then reduced five milliampères every two minutes until ten milliampères were reached, when the current was discontinued. The needle was now removed, the wire cut off close to the skin and then pushed under the skin and iodoform collodion applied over the puncture.

Care must be taken that the wire does not kink while being introduced; this may be prevented by using a proper wire and by having an assistant hold the spool properly while the wire is being unwound. It is a grave error to use from sixty to one hundred feet of wire as is frequently done. The object is not to fill the sac with wire but simply to furnish a material around which the blood may clot when the current coagulates it. When

a large amount of wire is inserted into the sac the very weight of the wire may cause a rupture of the sac.

Electricity may be used successfully in strictures of the esophagus, rectum and urethra. The negative pole should be attached to an insulated, metal-tipped sound—preferably an olive-shaped one—and inserted *down to* the stricture to be treated; the positive pole should be placed at an indifferent point. The object of using the negative pole at the point of stricture is because the negative pole will produce sloughing and thus soften down the stricture. By using a larger olive-pointed sound each day we are enabled to dilate the stricture greatly. We should be careful not to use force sufficient to push the sound through the stricture. We must wait patiently until the stricture is gradually dilated by means of the softening process. The strength of current will depend upon the sensibility of the patient. This method of treating strictures is now chiefly confined to stricture of the urethra. Other strictures may be successfully treated by the surgeon.

#### METALLIC ELECTROLYSIS.

This term is sometimes employed in electrolysis. The term is very misleading as it is well known that we cannot cause electrolysis of metals. What we really do is to introduce metals into the tissues. It is in reality cataphoresis. Different authors state that when a copper electrode is employed we obtain a double salt of oxychloride of copper. Now arises the question as to whether or not the copper can be carried into the tissues in sufficient quantity to produce poisoning. That this is really not the case may be easily proved by weighing the copper electrode both before and after experimenting upon a piece of fresh tissue, *e.g.*, a piece of meat.

Every operator knows that a bare positive electrode will adhere when applied on mucous surfaces. This is caused by the positive pole dehydrating the tissues. Some operators try to prevent this by changing the polarity to negative. This is not good practice. To prevent adhesion we should cover the positive electrode with absorbent cotton, or, if that seems impracticable,



the positive electrode may be gently rotated and the current disconnected before adhesion takes place. In endometritis, indolent ulcers, lupus, and even in trachoma, the bare positive copper electrode gives excellent results.

The copper also helps to prevent cauterization of the tissues at the point touched by the positive electrode; consequently we do not find the ordinary hard and unyielding cicatrix usually seen under the positive pole.

## CHAPTER VII.

### CATAPHORESIS.

---

CATAPHORESIS, or electric transfer, or osmosis as it is variously termed, is a physical property of the galvanic current that has been taken advantage of in the endermic administration of remedies. If we desire to carry a metal, an alkali, or an alkaloid into the deep layers of, or through the skin then the covering of the positive electrode should be wetted with the medicated solution and placed over the point where we wish the action of the remedy. Should we desire to test the action of iodine or of the acids on the deep tissues the covering of the negative pole should be wetted with the medicated solution. Should we use a solution of iodide of potassium on the positive electrode we should not be deceived, by the discoloration of the skin under the electrode, into believing that we are forcing iodine into the tissues, for we are securing only a very superficial application of a weak solution of iodine in iodide of potassium.

The element which goes to the positive pole is charged with electro-negative electricity and consequently cannot go to the negative pole—for likes repel and unlikes attract. If we will but remember the law that “likes repel and unlikes attract” there will be no confusion. At first sight we might think that all medicines should be placed on the positive pole and thus be carried to the negative because, as we have stated, electricity in the form of the constant current always goes from the positive to the negative pole. If we but remember that in electrolysis one pole has an affinity for a certain element, we may easily understand why it is very necessary to know the proper electrode upon which to apply our medicament.

If we wish to apply by cataphoresis a solution of iodide of potassium to an enlarged gland, we should remember that iodine is an electro-negative element. If the medicated solution be applied on the positive pole, placed over the enlarged gland, the

iodine cannot go to the negative pole—for like repels like, so the iodine must necessarily remain at the positive. The iodine has remained on the surface and has not at all penetrated into the underlying tissues. Let us now apply the solution on the negative electrode and watch the result. The iodine will at once be driven from the negative pole—for like repels like. The iodine in its passage to the positive pole must traverse the tissues and so produce the desired effect. In a solution of iodide of potassium the iodine takes the place of an acid; the potassium is a base and hence will be attracted to the negative pole.

Bromine, chlorine, iodine and oxygen are all electro-negative elements and hence go to the positive pole. Nearly all of the metals are electro-positive elements and so will appear at the negative pole.

An electro-negative element will appear at the positive pole because as likes repel, so an electro-negative element will be driven from the negative to the positive electrode. Now, if the element appear at the positive electrode it is known as an An-ion because the anode is positive. Much confusion often arises from the fact that an electro-negative element is often spoken of as an Anion. In the same way the electro-positive element is driven from the positive electrode to the negative and so must be a Cat-ion, for the negative pole is the cathode.

If we but remember the law of “likes repel and unlikes attract,” there need be no confusion.

When we wish to use a dilute Lugol's solution in treating an enlarged gland, we may use an ordinary all metal hypodermic syringe to carry the solution down into the gland and then connect the syringe to the negative pole of the battery. Sometimes we use the syringe to inject a few drops of a solution of cocaine into a mass to be removed, and then by connecting the syringe to the negative pole we use sufficient current to decompose the mass or growth. If we wish to do a minor surgical operation and first use a solution of cocaine we apply the cocaine on the positive electrode so that the cocaine in seeking the negative electrode will be compelled to traverse the tissues and produce local anesthesia.

We should remember that all bases whether alkaloidal or

metallic, have an affinity for the negative electrode. If, while remembering this fact, we are still in doubt upon which electrode to apply the medicament, we need but remember that "likes repel while unlikes attract." If we wish to apply a base which we know has an affinity for the negative we utilize this unfailing law and apply the medicine on the opposite electrode which, of course, is the positive. Acids have an affinity for the positive electrode; so for this reason we would apply acids on the negative in order that they may be driven to the positive. About 1860 Dr. Richardson applied morphine by means of the positive electrode and so produced local anesthesia. Since that time many remedies have been introduced by means of cataphoric action. The strength of the current depends upon the part of the body that is to be treated, the strength being anywhere from six to twenty-two milliampères. It does not matter much what strength of drug solution is used, as the stronger the solution the quicker we get the result and consequently the shorter the treatment.

The following arguments may be offered in favor of anesthesia by cataphoresis:—

1. There is no danger of forming a drug habit, in so much as our patient need never know we are using any drug. Every intelligent physician realizes with what fear and trepidation he gives his first injection of morphine in a chronic disease, knowing the great danger of producing morphinism.

2. It is very easy to produce anesthesia over a large area.

3. In producing the anesthesia there need be no pain. This is very important in treating an area of inflammation.

4. In giving drugs hypodermically to produce a local anesthesia, there is always danger of a sufficient amount of the drug getting into the circulation and so producing a systemic effect. By cataphoresis only the terminal filaments of the sensory nerves come in contact with the drug which is never forced into the absorbents, as is the case in producing local anesthesia by means of the hypodermic method. The opponents of cataphoresis claim that local anesthesia can be produced as well without electricity if the remedy be placed upon the skin. However, if we apply a solution of cocaine on our own hand without electricity, and then

apply the same solution with electricity we will soon be convinced. In using a cocaine solution in cataphoresis we always place it on the anode; if placed on the cathode no result will be obtained. The strength of the cocaine solution varies from 4 to 20 per cent. Sometimes an alcoholic solution of aconitine—gr. iv. to one ounce—about a 1-per-cent. solution—is used with a 10- to 20-per-cent. solution of cocaine, and much better results are obtained than from using the cocaine solution alone. The following mixture was used by Richardson, in 1860, to produce local anesthesia:—

Tinct. aconiti,  
 Chloroformi .....āā f3j.  
 Ext. aconiti alc. ....gr. vj.

This should be used at one application on the anode for ten minutes.

It has been said that chloroform is an insulator and so does not conduct at all. It has also been said that local anesthesia by means of chloroform can be produced just as readily when no electricity is used. As a matter of fact chloroform applied to the bare skin without electricity will produce a slight anesthesia, but of the skin only and not of the underlying tissues. Any physician can convince himself of the truth of this assertion by making the experiment. We should remember:—

1. Although the anode is known to have a transitory soothing effect over a painful area, the electric current alone will not produce local anesthesia at either pole.

2. While an alcoholic solution of aconitine, an alcoholic solution of cocaine, or chloroform itself, may produce a slight local anesthesia after a long time, these same solutions will in a few minutes produce a strong local anesthesia if cataphoresis be used.

3. These solutions must always be applied by means of the anode.

4. A 20-per-cent. solution of cocaine, by cataphoresis on the anode, will produce in severe neuralgias great relief for a period of from five to fifteen hours, and will also allow a small operation to be performed.

5. Cataphoresis may aid greatly in differentiating a neuralgia, a hysterical pain, or a pain caused by a lesion not near the periphery. If the pain be not relieved by a 20-per-cent. solution of cocaine applied by means of the anode, we may be certain that we are dealing with either a deep-seated lesion or a case of hysteria. A solution of aconitine alone will produce a deep analgesia but will, at the same time, cause severe smarting. This may be prevented by using a 20-per-cent. solution of cocaine with one per cent. solution of aconitine.

The solution introduced by cataphoresis does not cure. It simply palliates or ameliorates. Chloroform by cataphoresis may produce vesication. Cataphoresis is applicable to the skin and to the mucous membranes. A mild solution of carbolic acid is sometimes used by cataphoresis. Sometimes about four drops of a 1-per-cent. solution of helleborine are applied on the anode and have produced local anesthesia. We are so accustomed to think of galvanic electricity in conjunction with diagnosis, for the stimulation of muscles and nerves, for cauterization, lighting and endoscopy, that we may entirely forget its cataphoric action.

It seems hardly necessary, after what has already been said, to state that the positive is not always the pole upon which the remedy is placed, notwithstanding the fact that some authors teach that all medicaments are applied by means of the positive pole. Electricity goes from the positive to the negative, but it does not follow from this that the medicament must always be placed upon the anode. Cataphoresis means the splitting into ions of the medicament and then the electro-negative element is of course driven from the negative to the positive pole. In the same manner the electro-positive element is driven to the negative pole.

If we wish to apply a solution of citrate of lithium in order to get the action of the lithium, we must proceed in the following manner: Knowing that lithium is a base and that all bases have an affinity for the negative, we apply the lithium citrate solution to the positive pole. The lithium will seek its affinity—the negative—and consequently will be obliged to pass through the tissues, thus giving the desired action. If the action

of the citric acid be desired we apply the solution on the negative electrode when the lithium base will remain at this electrode and the citric acid will seek its affinity, the positive pole.

In 1816 Poyret absolutely demonstrated the truth of cataphoresis. Clemens, in 1858, used iodine by cataphoric action. It was shown that animals might be killed by using strychnine by this method.

Richardson's production of local anesthesia by cataphoric action in 1859 met with great opposition from the members of our profession. While the medical profession was slumbering, tanners were wide awake enough to know that within a week a hide might be tanned by applying a tannin solution by cataphoric action, whereas the old method required nearly a year's time to accomplish the same result.

Not only is cataphoresis at present well established, but Professor Morton goes so far as to state that by means of the galvanic current demedication of the system may be obtained as for instance—the removal of poisons such as lead and arsenic. Morton has adopted a plan called Anemic Cataphoresis. In this method he cuts off the blood-stream in the limb to be treated by using an Esmarch bandage. In some cases he uses circular compression when the Esmarch bandage is not feasible.

A great many electrodes have been devised for use in cataphoresis, but usually the ordinary electrodes covered with cotton will answer just as well, and, in some cases, much better.

Cataphoresis, it may be summarized, is used:—

1. To produce local anesthesia in superficial pains and in neuralgias and in minor surgery and dentistry.
2. In syphilitic, rheumatic and gouty affections to apply remedies locally.
3. Sometimes, in the cataphoric bath, to produce systemic effects.

If we wish to use cocaine by means of the electric current a few important things should be noted. It was at one time taught that all remedies should be placed on the *positive* pole because the current goes from the positive to the negative. While it is true that the current does travel from the pole of higher potential—the positive—to that of lower—the negative—

it is a fallacy to say that all remedies for cataphoric action must be placed on the positive pole. In the case of cocaine we place the medicament on the positive pole because we know that bases are attracted to the negative pole and so are made to traverse the tissues and produce an anesthesia. It is well to remember that, as in employing any salve containing cocaine, we always employ the alkaloid cocaine instead of one of its salts, we should use cocaine itself dissolved in alcohol when obtaining the cataphoric action of the drug.

At one time the statement was made that malignant tumors might be cured by the cataphoric action of drugs. All that need be said for this is that cataphoresis cannot remove the adjacent lymph glands. I think it is a safe rule never to treat a malignant tumor with electricity unless some reputable surgeon assures us that the case is inoperable. Malignant tumors, if seen early, should at once be sent to a surgeon.

If we wish to use quinine sulphate by cataphoric action, we wet a pad covering the positive pole with a solution of the remedy. The quinine will pass to the negative pole and in so doing will traverse the tissues. Some authors state that a solution of iodide of potassium should be placed on the positive pole. The following argument will at once prove conclusively that this technic is faulty. It is a well-known fact that iodine added to starch-water will produce a blue color. If we wet a pad with starch-water and apply it on the negative pole, no blue color is seen at this pole when the potassium-iodide solution is applied on the positive pole; the reason being that the iodine remains at the positive pole for which it has an affinity, while the potassium seeks the negative which has an affinity for bases. Now, if the starch-water be applied on the positive pole and the potassium-iodide solution on the negative, the iodine will, when the current is applied, traverse the tissues to the positive pole and there produce the characteristic blue color of the iodide of starch. This experiment may be beautifully demonstrated by using a piece of fresh, raw beef, and placing the poles as just described.

Obstinate cases of tic douloureux may be helped very much by introducing the salicylic ion by cataphoric action.



## CHAPTER VIII.

### ELECTRICITY IN SURGERY.

---

THE first question we should ask ourselves is whether electricity can be of any service in surgical cases when the knife fails. Of course it is known that Hagedorn removed a leg by means of the *écraseur* cautery loop, and that Bruns has amputated by the aid of the electro-cautery; but these methods are certainly not to be recommended.

By means of the different electroscopes we are enabled to obtain efficient aid in exploring the bladder, urethra, and other cavities, while the Röntgen rays lend valuable aid also in arriving at a correct diagnosis. We employ electricity in surgery to coagulate the blood in aneurysm and in hemorrhage, to remove warts, moles and superfluous hairs, to destroy nevi, and to dilate strictures, as already detailed.

At this point it may be well to call attention to the fact that many books on electro-therapeutics advocate the destruction of cancerous growths by the aid of electricity. It is, however, the consensus of the highest opinion that such attempts are worse than useless and that valuable time may be lost and a life sacrificed, that might perhaps have been saved by prompt surgical interference. Very superficial rodent ulcers may possibly be cured by electrical treatment; but, even these cases should be sent to the surgeon.

The electric cautery is sometimes used in surgery, its chief advantage being that it may be introduced into a cavity when cold and then brought up to any temperature required. Wherever the knife can reach, there is no excuse for the electric cautery, unless in those cases where the actual cautery should be employed. The electric cautery is used in surgery in the form of a wire loop or blade. Either of these can be applied cold,

and, as just stated, brought to the required temperature and there maintained. For this reason we are enabled to destroy tissue without the danger of hemorrhage, and to leave a thin crust instead of the thick slough seen after the use of the white iron formerly used.

To obtain the current necessary for cautery work, it is essential to have a large quantity or ampèrage; we therefore connect the cells in multiple or parallel, *i.e.*, we connect the zinc of one cell to the zinc of the next cell, and the carbon of

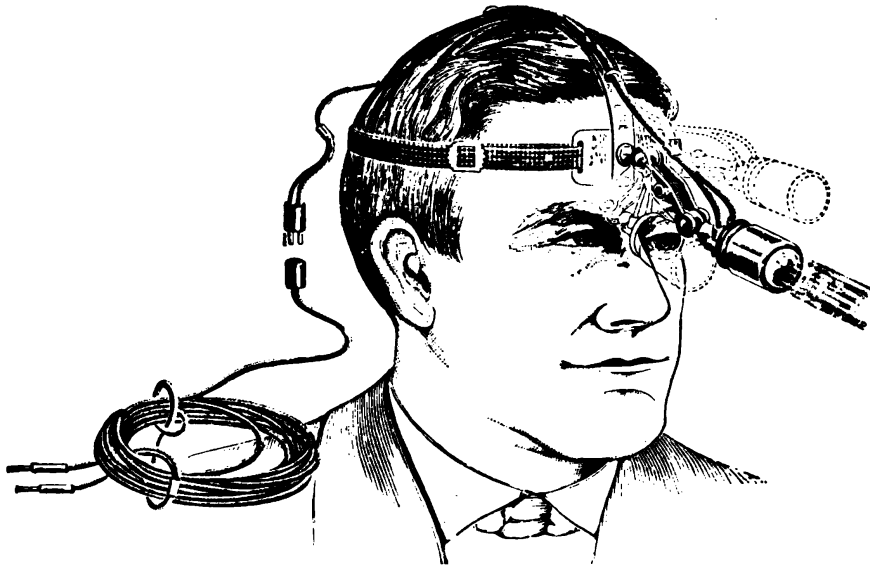

Fig. 54.—Victor head lamp.

the first cell to the carbon of the second cell, and so on throughout all the cells. By this method we can heat the platinum loop so we can secure a dull red or a white heat. We should remember that the greater the heat, the less pain is produced but that there is more danger of subsequent hemorrhage. The dull red heat is very painful and this heat may cause hemorrhage by tearing the tissues upon removing the electrode. A temperature intermediate between red and white is usually the most satisfactory. It may not be amiss to state that we are never to administer ether when the electric cautery is to be employed around the face. The writer actually, upon one occasion, saw

ether administered when the Paquelin cautery was about to be used; fortunately no accident occurred.

The conducting cords of the electric cautery should be from eight to ten feet long; they should be flexible and have insulating covers, and should be as large as possible without being too heavy. The handle should be as light as possible, and should have an arrangement not only for making and breaking

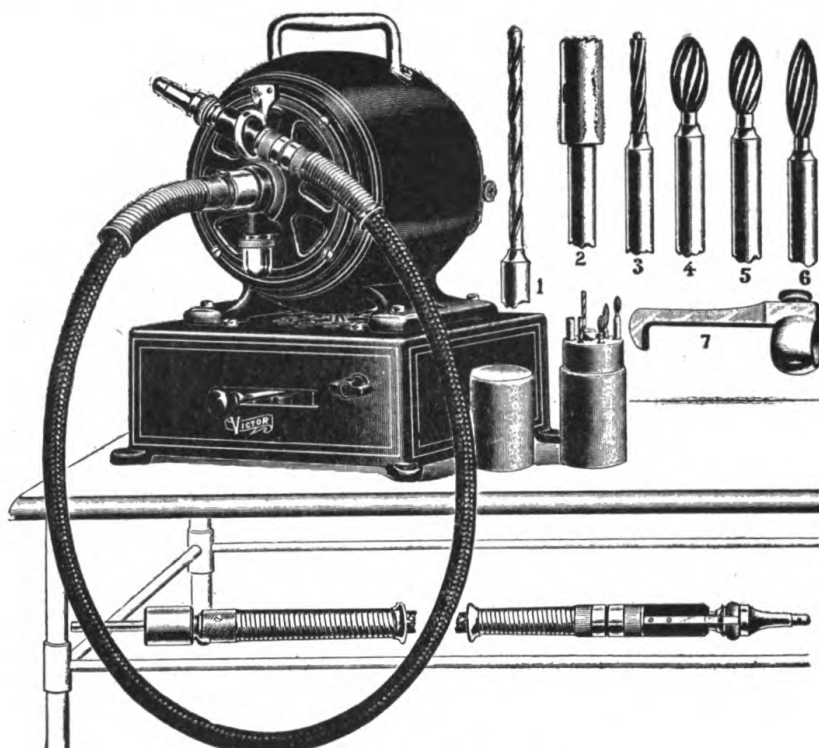

Fig. 55.—Victor bone engine.

the current but also for maintaining the degree of heat required. In some forms of cautery the arrangement for breaking the current is under the control of the operator's foot. Platinum is the best material to use; the size and shape of the platinum, *i.e.*, whether a loop or a blade, will be determined by the part of the body to be treated. The cautery has been used to cut through the tongue, and the cervix uteri; to remove polypi and tumors difficult to reach with the knife; to cauterize laryngeal ulcers; to remove growths in the pharynx and the larynx; sometimes

to arrest hemorrhage; to destroy a nerve in a hollow tooth; to blister in myelitis; to open an abscess in the lung after a rib has been resected; and to treat some cases of hypertrophy of the prostate. This last procedure was introduced about the year 1878 by Bottini, of Padua.

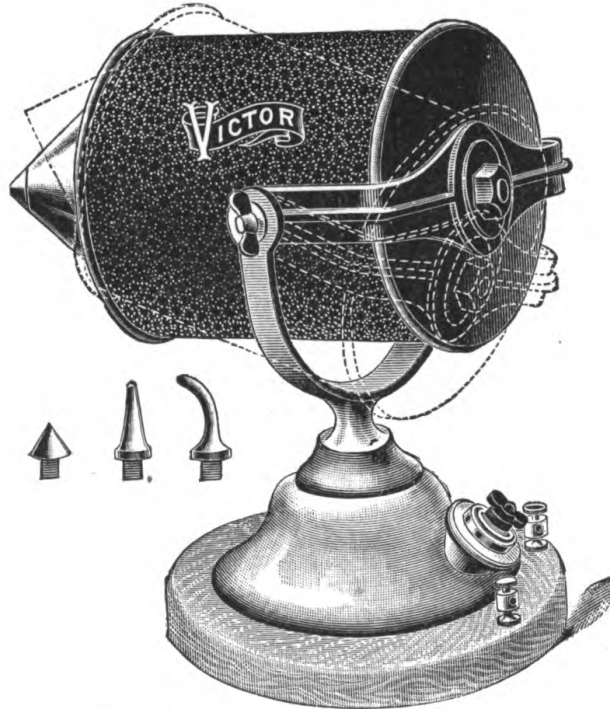

Fig. 56.—Victor giant eye magnet.

#### THE BOTTINI OPERATION.

The technic here given is that described by Freudenburg and Willy Meyer. The bladder should be washed out and emptied; the posterior urethra should be anesthetized by means of eucaine or cocaine. A special assistant should be detailed to see that the flow of water does not cease in the cooling apparatus. We should introduce the instrument with the current turned off. In order to burn a groove, the concavity of the instrument is rotated toward the desired spot; the instrument is then slightly withdrawn in order that the concave surface can press on the

prostate. The flow of water should now be started in the cooling apparatus, and the current turned on. We should wait for fifteen seconds in order that the blade may heat, then project the blade to the right and extend the blade by means of the screw on the handle. After burning the groove to the proper depth we should increase the current slightly so that the blade

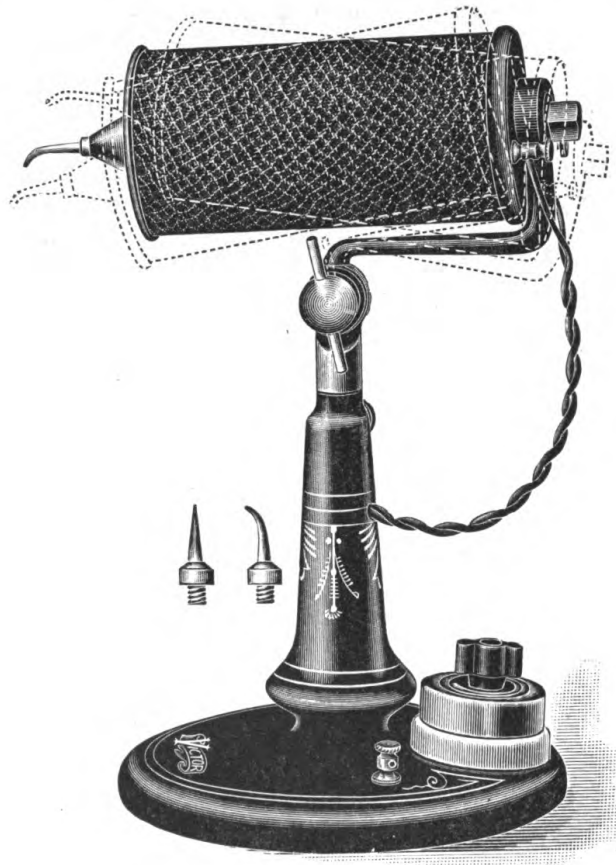

Fig. 57.—Victor little giant eye magnet.

will not adhere; we should return the blade to its sheath and turn off the current. Bottini makes three furrows, a moderately deep one toward the rectum, a shallow one toward the pubis, and a deep one into the lateral lobe which is the more enlarged. The whole operation should be completed in about five minutes. The advantages of this operation are that there will be little or

no pain, and usually no hemorrhage; the patient may void his urine shortly after the operation, and also arise from bed on the third day. -

Meyer states that out of 160 cases operated on by the Bottini method, 80 were cured, 40 improved, and 14 died.

#### THE REMOVAL OF SUPERFLUOUS HAIR.

A very useful method of employing electrolysis is for the removal of superfluous hairs. A fine irido-platinum needle is attached to the negative pole, and then is passed carefully down along the hair until the point of the needle reaches the papilla; the positive pole is covered with a well-wetted sponge and placed in the hand of the patient; five milliamperes of the galvanic current should be used. Very soon, a frothing is seen at the opening of the follicle, when a slight pull on the hair, by means of a forceps, should at once remove the hair. We should now break the current and remove the needle. The same procedure is followed with each hair. We should remember that we may produce a slight inflammation at the opening of the follicle, but this will disappear in the course of a few days. To avoid scars we should not puncture the follicle or attempt to remove too many hairs at one sitting. The X-rays promised valuable aid in depilation but, as the hair soon returned and there is great danger of an X-ray burn, the method has been abandoned.

Nevi are removed by making the positive pole the active one and the negative the indifferent pole. In this procedure, we should employ platinum needles having insulated shafts. We should insert several of the needles into the nevus, near the point where the veins leave the tumor. A galvanic current of a strength of from thirty to forty milliamperes should be employed and continued for from six to ten minutes. Before attempting to remove the needles, we should increase the current slightly, to prevent the needles adhering and to avoid after hemorrhage. We should not forget to move the negative—the indifferent—electrode from place to place on the sternum, otherwise sloughing may ensue. We should use the utmost care to prevent sepsis.

The bone surgery engine is now frequently employed and, of course, has many advantages over the old chisel and mallet plan.

Two types of eye magnet are shown here. Either one is preferable to the old form of eye magnet.

The cautery electrodes and the needles for electrolysis have been shown under Figs. 31 and 36, respectively.

An apparatus for administering ear massage is shown in Fig. 58.



Fig. 58.—Victor ear massage outfit.

## CHAPTER IX.

### SINUSOIDAL CURRENT.

---

THE sinusoidal current, which is a very useful form of electricity, is an alternating induced current. It derives its name from the fact that the relation to time follows the law of series. In the sinusoidal form the direction of flow is constantly alternating, and bears a marked resemblance to the ordinary, pure faradic current. If we wish a muscular contraction at each end of an alternation, we arrange our apparatus so that we have from 15 to 20 alternations per second; if we wish a tetanic muscular contraction, we increase the alternations so that we have from 300 to 2000 per second. The voltage of the sinusoidal rises from zero to the maximum, falls again to zero, and, at once a reversed current is started which going through the same changes, completes the cycle. A good sinusoidal apparatus produces a perfect sine curve, which curve is called a sinusoidal. This current is smooth and has a gradual variation; it is very useful as a nerve sedative if a large number of alternations per second be used; it is also well adapted for muscular stimulation.

The accompanying diagram shows two alternations but only one cycle.

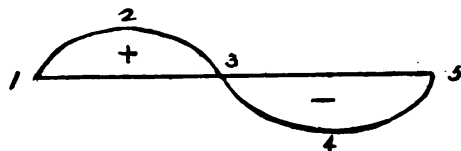

Fig. 59.—Drawing of sinusoidal.

When we speak of the frequency or periodicity of this current, we mean the number of cycles per second. In every cycle there are two alternations—one positive and the other negative. We sometimes read at one time of so many cycles



per *second* and at another time of so many alternations per *minute*. The following will explain what is implied by these terms.

1 to 5 = one cycle = 1 to 2 to 3 to 4 to 5.

1 to 2 to 3 = one alternation = the positive alternation.

3 to 4 to 5 = one alternation = the negative alternation.

Now, if we have 60 cycles per *second*, we must have 60 x 60 or 3600 cycles per *minute*; but each cycle has two alternations so we must have 3600 x 2 or 7200 alternations per minute; 3600 cycles per minute = 7200 alternations. This is very confusing to the mind, but need cause no trouble if we but remember that each cycle has two alternations; 60 cycles per *second* — 3600 cycles or 7200 alternations per *minute*. In electric power work we designate 25 cycles per second a low frequency current; a current of 133 cycles per second is spoken of as a high frequency current. The electro-therapist calls a current of 133 cycles per second a low frequency one and only speaks of high frequency currents when the change of direction of current takes place many thousands of times every second. The sinusoidal current permits us to use a greater milliamperage than could be employed by the pain producing properties of the primary induction current. If we are using a direct current dynamo, we may obtain a sinusoidal current by tapping the armature winding at two opposite points. The same is true if we have a direct current run as a motor and slip rings are attached. It is a well-known fact that the sinusoidal current acts differently upon the human body from all other forms of current. We know that the increase and decreases of electro-motive force in the sinusoidal are never abrupt or sudden, but that the alternations are always uniform and gradual. We should remember that the degree of electro-motive force, the quantity of current, and especially the number of cycles per second have everything to do with the physiological effects. The peculiar properties of this current are due to the uniformity of the alternations and the number of cycles per second. The uniformity prevents unpleasant sensations when we contract muscles. If we employ a current of but slight rise and fall, with but few cycles per second, we stimulate neither

muscle nor nerve. Now, if we increase the rise and fall, we get with each wave a gradual contraction and relaxation of the muscle. If we wish to cause these single contractions to run into one long contraction—*i.e.*, become tetanoid—we simply increase the number of cycles per second. Greater absorption of oxygen and greater elimination of carbonic acid are produced by using the sinusoidal current. About 30 cycles—60 alternations—per *second* will produce tetanization of the muscles of the human body. If, now, we run the alternations up to 5000 per second, we cause the stimulation of muscles gradually to disappear and by still further increasing the number per second we shall produce no noticeable effects on the muscle. The symbol  $\sim$  is used to mean an alternating current, so “120  $\sim$ ” would indicate an alternating current having a frequency of 120 cycles or 240 alternations per *second*.

Dr. J. H. Kellogg, of Battle Creek, Mich., about twenty years ago, discovered the peculiar power which the sinusoidal current has of causing muscular contraction without producing pain. This was really the beginning of the therapeutic use of the sinusoidal current. Some years afterwards, d'Arsonval, of Paris, in experimenting with high-frequency currents made further observations in relation to this peculiar modality and then gave to it the name sinusoidal by which it is known. Kellogg experimented with low-frequency currents while d'Arsonval's experiments were made exclusively with currents of high frequency. From this it may be seen that d'Arsonval must necessarily have overlooked some of the very important conditions for which this current may be employed. By using an electrograph we may see by the tracings the difference in character of the faradic, galvanic, and sinusoidal currents. The sinusoidal current bears a marked similarity to the faradic current in that the motor effects vary according to the rate of alternations. The sinusoidal is especially adapted for stimulation of the muscles. The sinusoidal current's effects are its painlessness and its great penetrating power. The galvanic current is continuous. Any change in direction or interruption of current is a sudden and abrupt break accompanied by painful shock. The faradic current is an alternating current in which

the break or change in direction of current occurs at the maximum point of intensity. In the sinusoidal current, however, these conditions which are necessarily productive of pain and irritation do not exist. The slowly alternated current, often designated as S. S. (meaning slow sinusoidal), is usually employed for muscular effects. The rapidly alternated, known as R. S. (meaning rapid sinusoidal), is used when we desire to produce powerful tonic contractions and when analgesic or other nerve effects are desired.

#### METHODS OF APPLICATION OF THE SINUSOIDAL CURRENT.

1. **Passive Exercise in Muscular Paralysis.**—For exercising weakened muscles the sinusoidal current is the best method to employ. We use this current in cases of paralysis due to apoplexy, in infantile paralysis, and in all forms of muscular weakness in which the muscle will respond to an induced current. We should remember that the sinusoidal current will produce contractions in many cases in which the faradic current fails to produce any visible effect.

If a sponge electrode be placed in each hand, all the muscles of both arms will be thrown into vigorous muscular action, absolutely without pain. If we wish to exercise one arm only, we place one sponge electrode in the hand and the other between the shoulders. If we wish to exercise the muscles of both legs we should place each foot in a separate bath tub and connect one electrode to each tub. To exercise the abdominal muscles we should place a large electrode on the abdomen and the other over the lumbar region. No pain is caused although the abdominal muscles are brought into vigorous action. In the same manner we may exercise the muscles of the face, neck, chest, or any other part of the body by applying the electrodes at suitable points. We get contractions without pain.

2. **In Obesity and in Diabetes.**—In obesity and in diabetes a general application of the slowly alternating sinusoidal current will cause contraction of the muscles all over the body and so greatly benefit the patient. In obesity a large amount of

muscular activity is needed to burn up the surplus fat. In diabetes it may happen that the patient is so weak that any considerable amount of exercise may excite excessive proteid metabolism. We should remember that twenty contractions per second will mean twelve thousand contractions in ten minutes. From this it may easily be seen how much work may be obtained from the contraction of the muscles by means of the sinusoidal current.

**3. Atrophied Muscles.**—The muscles frequently waste to an extraordinary degree in invalids who have been confined to bed for a long time. The sinusoidal current will show a rapid muscular development if daily applications are made. If daily applications of this current are used on the abdominal muscles we will see not only a development of these muscles but also an improvement in the nerves, together with a marked improvement in the tone of the muscles. It has been shown that the sinusoidal current, by contracting the blood-vessels of the splanchnic circulation, aids in improving the general blood circulation. Visceral neuralgias are relieved by the analgesic effect of this current, and by the relief of the congestion. In treating visceral neuralgias we should employ the more intense rapidly alternating sinusoidal current—known as R. S. We should use large electrodes and place one over the lumbar region while the other is placed on the abdomen over the painful part; the treatment should last for a period of ten minutes.

**4. Neuralgia and Neuritis.**—In chronic neuritis, sciatica, lumbago and intercostal neuralgia, we can often obtain results from using the rapid sinusoidal current (R. S.). This current seems to have a very good effect on the nerve structures because of the improvement in the circulation of the blood. Always start with a very mild current and increase the strength gradually.

**5. Constipation.**—Relief of constipation often follows the use of the sinusoidal current on the abdomen externally, and to the rectum internally by means of a rectal electrode. If the constipation be due to diminished sensibility of the rectal structures, we employ the rapid sinusoidal (R. S.); in other cases, we use the slow sinusoidal (S. S.).

6. **Pelvic Disease.**—In pain due to a neuralgic condition of the ovaries or tubes, in cases in which the uterus is very sensitive but no acute or chronic endometritis is present, the rapidly alternating sinusoidal current (R. S.) will give most satisfactory results. This current will often give relief in cases of dysmenorrhea not accompanied by endometritis or the discharge of a false membrane. Treatment for a period of ten minutes should be given. We should also employ the hot douche, sitz-bath and other forms of hydrotherapy. Whenever passive congestion is present we should use one electrode on the abdomen and the other applied to the uterus; we should employ the rapid sinusoidal current for ten minutes and then use the slow sinusoidal for five minutes.

#### THE SINUSOIDAL ELECTRIC BATH.

There is no doubt that this form of electric bath is the best method of giving a powerful general electrical treatment. We are permitted to apply currents of greater magnitude because the sinusoidal current is a painless one. The current usually applied in electric baths is the faradic. It is well known to electro-therapeutists that only a small amount of faradic current can be used. When the sinusoidal electric bath is used, we will find hardly any pain although nearly every group of muscles will be brought into action. If a patient be put into a bath at 85° F. he will complain at once of being cold, but when we apply the sinusoidal current and produce muscular contractions the patient rapidly becomes warm because of the muscular activity. If we apply the sinusoidal bath for five minutes, at 90° F. and use the rapid sinusoidal current, we will obtain tonic effects not produced by any other form of bath. The lowering of the temperature of the bath will increase the tonic effects, and patients will readily endure a temperature of from 85° down to 80° F. with this current, a degree of temperature which could not be borne in an ordinary bath.

When we wish to produce alterative or metabolic effects, we continue the bath for from twenty to thirty minutes.

The sinusoidal bath may be used in gout, chronic rheuma-

tism, obesity, diabetes, gastric forms of neurasthenia, locomotor ataxia, insomnia, myalgia, secondary anemia, and in many cases of chronic cardio-vascular disease with or without renal complication. In some cases of chronic nephritis this bath is very

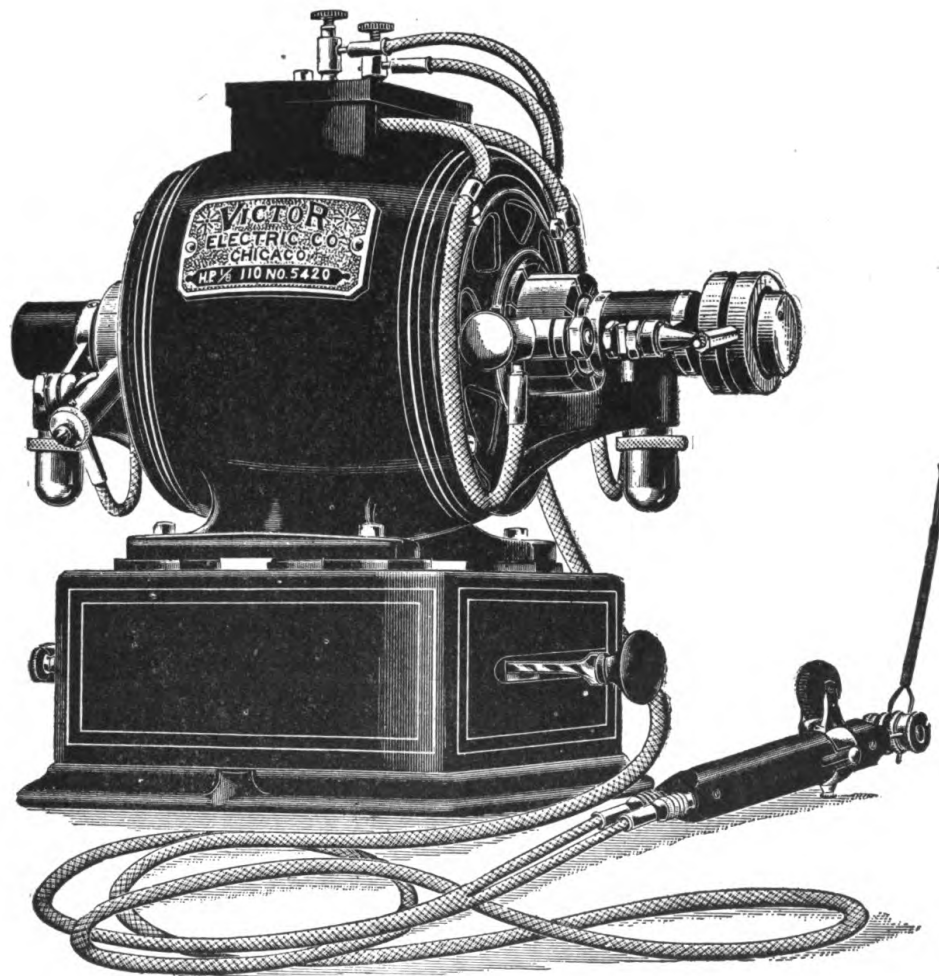

Fig. 60.—Victor No. 9 transformer.

useful. In the sinusoidal current we see a rise and fall in the positive direction immediately followed without a break by a corresponding fall and rise in the negative direction. Local applications may be made in all the diseases and disorders named above.

The sinusoidal apparatus employed by the author is the one made by the Victor Electric Company. This apparatus is shown in Fig. 60, the motor transformer for generating the sinusoidal current resting on the shelf of the floor cabinet.

In Fig. 60 is shown a transformer which delivers both cautery and sinusoidal currents.

## CHAPTER X.

### HIGH FREQUENCY CURRENTS.

The high frequency currents were discovered by Professor William J. Morton, of the New York Post Graduate School and Hospital, in the year 1881. The author thinks that this is the first American book to accord to Dr. Morton the credit he so richly deserves. He has already received in France, and later in England, the honor due him. His prophecy contained in a paper read before the New York Academy of Medicine in March, 1881, has been fulfilled. He then said:—

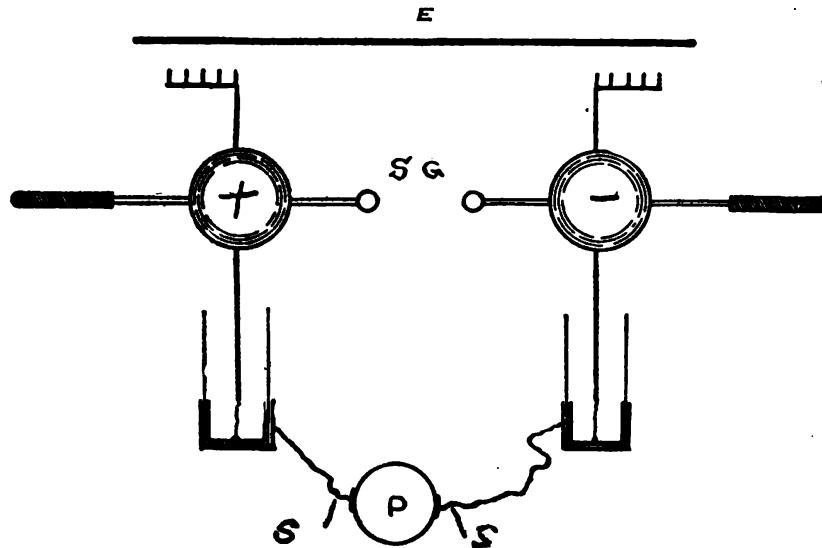

Fig. 61.—Drawing of Morton's static induced current of 1881.

“I have invented a new induction current in medical electricity which I have named “The Static Induced Current.” I think that this is an entirely new current in medicine and that it has a record to make.”

(119)



There is no doubt that this was the fundamental high frequency current of the present day, modified very simply to produce the so-called Tesla, d'Arsonval and Oudin currents. It may be argued that the Cavallo apparatus of 1780, with which were used the Lane electrometer and the Leyden jar, was the first to furnish high frequency currents. As a matter of personal experience anyone who has received the shock from a Leyden jar knows the peculiarly distressing general sensation which makes him dread a second shock.

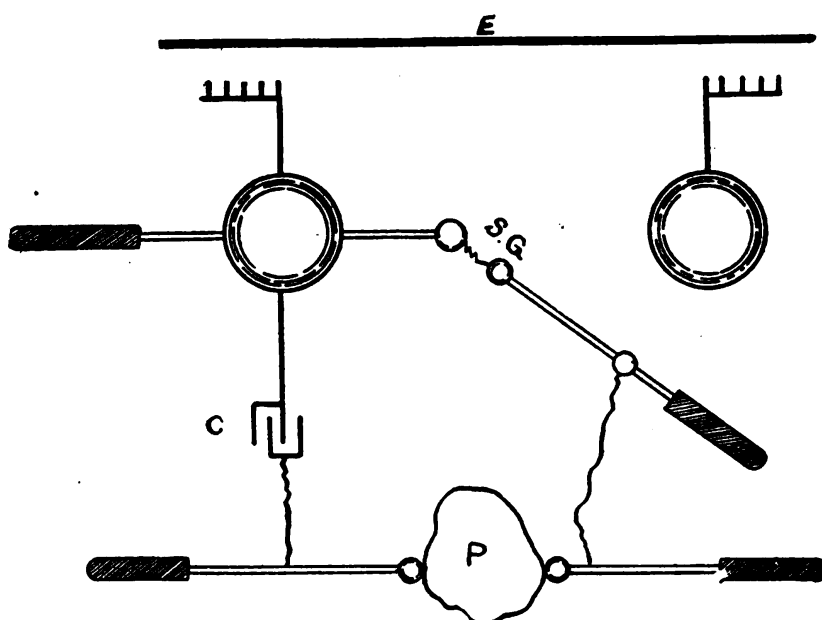

Fig. 62.—Drawing of Cavallo apparatus of 1780.

In the Cavallo method the circuit of discharge of the Leyden jar condenser is completed through the patient and the spark-gap, which are in simple series. The therapeutic effect of the direct Leyden jar discharge is most harmful. By the modern methods, invented by Morton, the direct discharge traverses the spark-gap, but does not traverse the patient.

Sir Oliver Lodge, in his intelligent and forceful manner, has taught us that the Cavallo apparatus oscillatory discharge has the *plus* in excess in one direction and, if it is strong enough, will kill an adult. He also proved that the modern method as

taught by Morton, produces a current which, however strong, should have no perceptible effect.

On December 2, 1890, Dr. Morton, in a lengthy communication to the New York Neurological Society, amplified and continued his earlier publication of the year 1881. This was prior to any publication along these lines by d'Arsonval or Tesla. On February 24, 1891, d'Arsonval communicated to the Society of Biology a paper on high frequency currents. In settling the question of priority it is well to note that d'Arsonval's

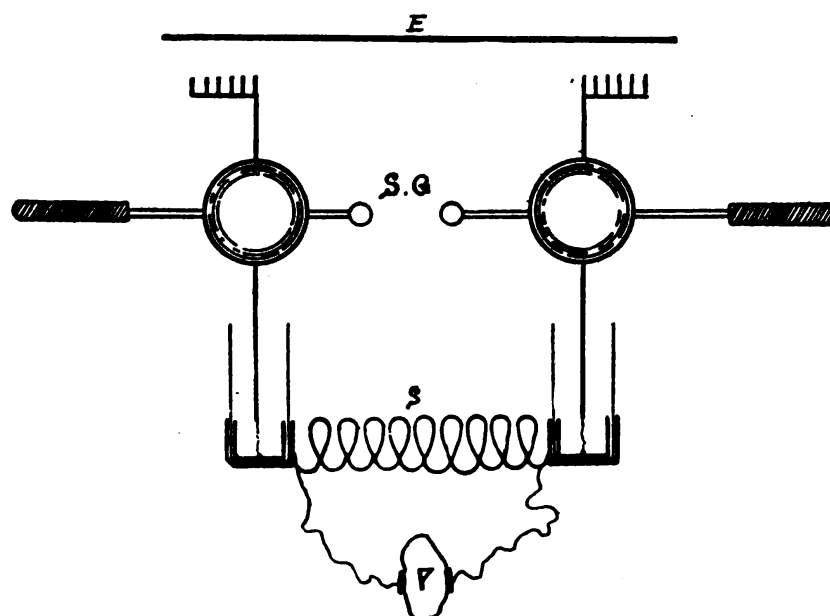

Fig. 63.—Drawing of d'Arsonval apparatus.

paper was read exactly one month after Morton's paper had appeared in print on January 24, 1891.

In May, 1891, there was published a paper on this subject by Professor Elihu Thomson.

On May 20, 1891, Nikola Tesla, in a lecture delivered before the American Institute of Electrical Engineers, spoke of high frequency currents. This was four months after Morton's publication appeared.

In the d'Arsonval modification, we utilize a static induced circuit solenoid of from 15 to 20 turns, leaving the rheophores and patient as in using the Morton method.

Tesla transformed the static induced current upwards as is done in the ordinary induction coil. If we take the Morton method and adapt a fine wire secondary circuit to the static induced circuit solenoid, we at once have Tesla's method.

The work of Oudin added greatly to a more thorough knowledge of high frequency currents.

No less an authority than Dr. Bordier, one of the greatest authorities on electro-therapeutics in France, gives full credit to Dr. Morton for discovering high frequency currents. Later,

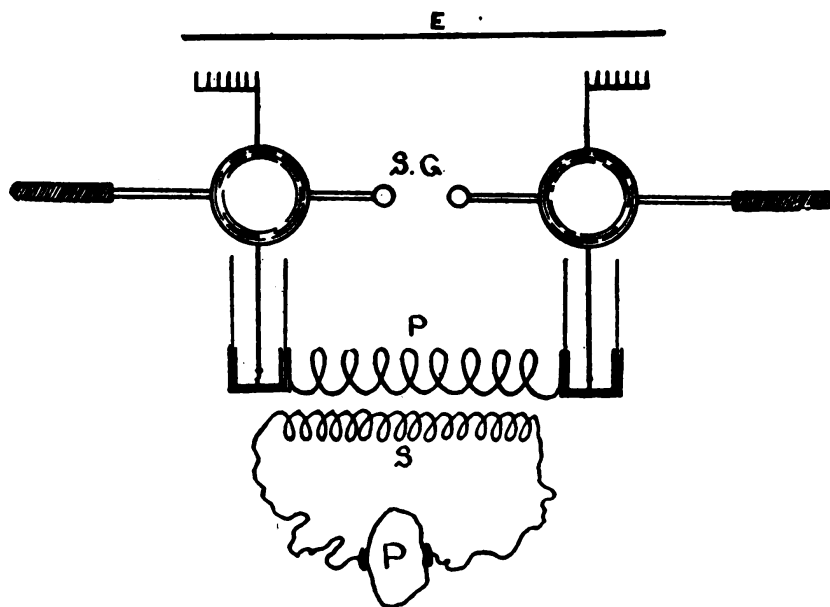

Fig. 64.—Drawing of Tesla apparatus.

this recognition came from England. It is remarkable that twenty-eight years had to elapse before Dr. Morton received, as he does in the present book, adequate recognition on this side of the water. The accompanying diagrams, with the dates given, prove conclusively that Morton's claim to priority is fully established. It should be remembered that Morton produced high frequency currents by using a static machine, while an induction coil was employed later by Thomson, d'Arsonval and Tesla.

It has been proposed to change the term "Static Induced Current" to "Hertzian Franklinization." It has also been suggested that the term "Franklinization with Indirect Sparks" would appear to be an improvement over the term "Morton Wave-Current." However, this does not at all appeal to the writer. Every electro-therapeutist knows exactly what is meant by the terms employed by Morton.

D'Arsonval taught us nearly all we now know of the effects on the human body of high frequency currents. He gives the following actions:—

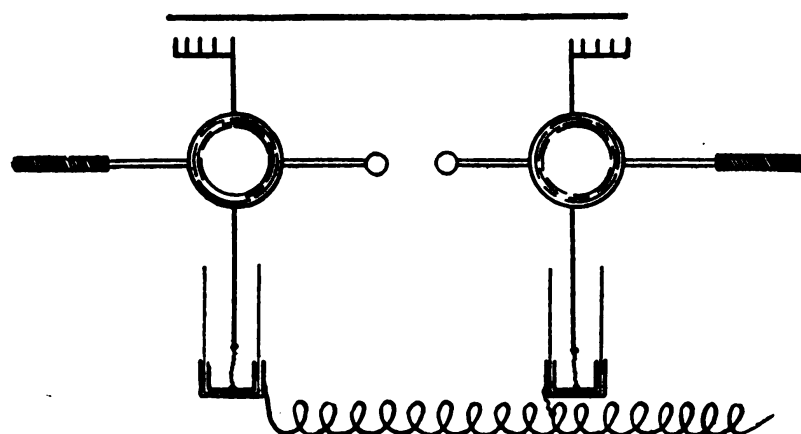

Fig. 65.—Drawing of static current through a solenoid.

(a) An entire absence of effect upon the general sensation and upon muscular contractility.

(b) A marked influence on the vasomotor nervous system.

(c) Marked assimilative and nutritive changes. Increased heat production in the body as well as increased absorption of oxygen and increased elimination of  $\text{CO}_2$ . There is increased heat dissipation *without* a lowering of the bodily temperature.

In the year 1891, Nikola Tesla so forcibly called the attention of electrical engineers to the wonderful effects of the high-frequency currents that we often, at the present time, speak of "Tesla currents" when we really mean the high frequency currents.

**GENERATION OF HIGH FREQUENCY CURRENTS.**

In the generation of the high frequency currents we now have:—

- (a) The Morton method.
- (b) The d'Arsonval method.
- (c) The Tesla method.
- (d) The Oudin method.

The foundation of these methods is practically that each one uses the disruptive discharge of a condenser to produce vibration, or the "to-and-fro" movement of the current.

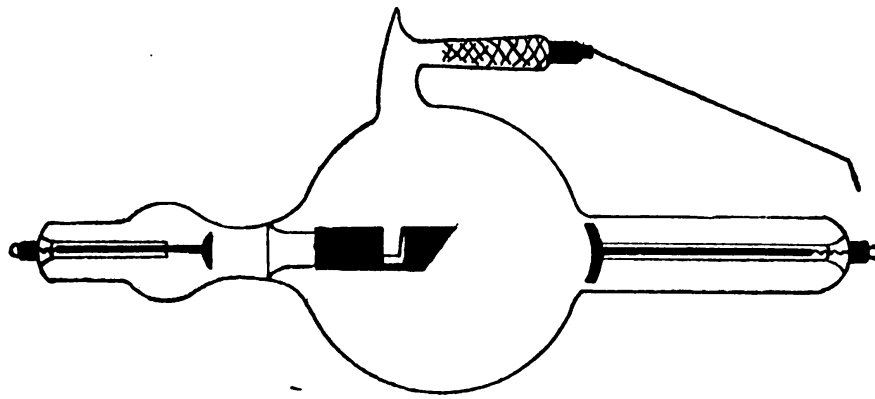

Fig. 66.—Campbell X-ray tube.

Much has been written lately upon the subject of high frequency currents. In fact, so many contradictory statements have been made that it is at times difficult to know what to believe. Although d'Arsonval was enabled to pass, through the human body, currents of high frequency which at a lower frequency would have been fatal, his apparatus has the serious drawback that it will produce only a current of low voltage. He used a solenoid. Oudin, to overcome the disadvantages of the d'Arsonval method, added a resonator. This raised the voltage very much. In Europe, the Oudin apparatus gave excellent results because of the care with which it was made. In this country we obtain our high frequency currents princi-

pally from the static machine and from an apparatus based on the induction principle as employed by Tesla. In this apparatus there is used a disruptive discharge coil, or high frequency transformer. By means of the Tesla apparatus the sixty-cycle, street-lighting current of one hundred and ten volts may be transformed into a high frequency current of one million volts, and a million oscillations *per second*.

At Jefferson Hospital, where the direct instead of the alternating current is supplied, there is used a rotary converter to change the direct current to an alternating one.

If the alternating current, having a low voltage and a low frequency, be used, it is, of course, passed through a transformer which furnishes a current of high voltage but still of low frequency. We will now have a current of about twenty-five thousand volts, but still a sixty-cycle current—the current we started with being a one hundred and ten volt and a sixty-cycle current. The next step is to increase the frequency without changing the voltage, now twenty-five thousand volts. This is accomplished by means of a condenser which, for explanatory purposes, may be considered as many large Leyden jars. By means of this condenser we are enabled to cause a disruptive discharge across the spark-gap, thus liberating very rapidly the energy which has accumulated very slowly. This increases the frequency, and we now have both high frequency and high voltage. To raise both of these still higher, we pass this last current through the primary coil; this is done to induce in the secondary coil of Tesla a current of possibly one million volts with a periodicity of one million times *per second*.

In this country, we charge the primary of the transformer by means of the ordinary street-lighting current, either alternating or direct; and we use a high potential transformer with a closed magnetic circuit to charge the condenser. In Europe the condenser is charged by a current obtained from a static machine or from an induction coil.

One American firm has to-day on the market a very efficient high frequency and X-ray apparatus which is so small and compact that all of the apparatus, with the exception of

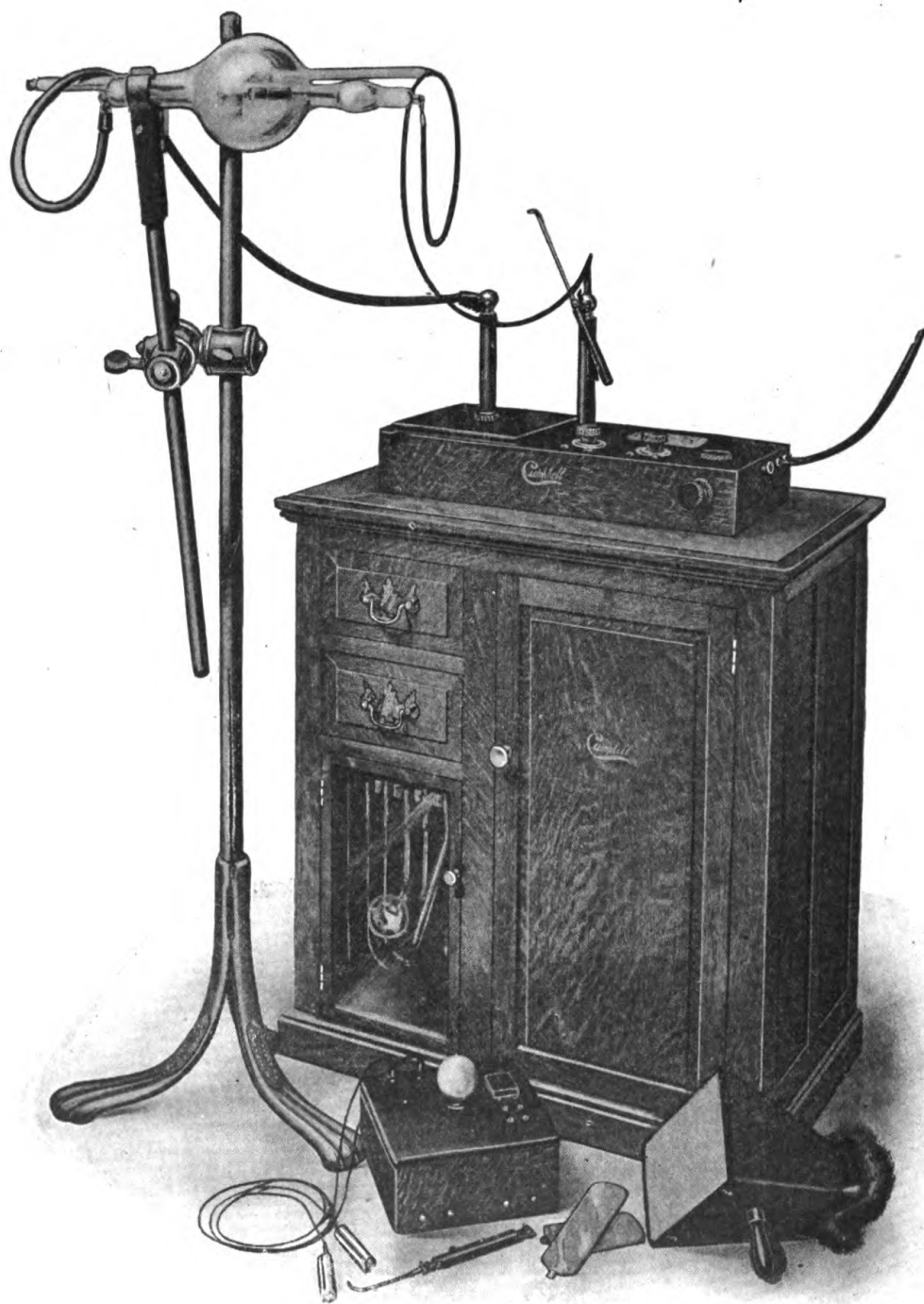

Fig. 71.—Campbell model "D" coil, cabinet and X-ray.

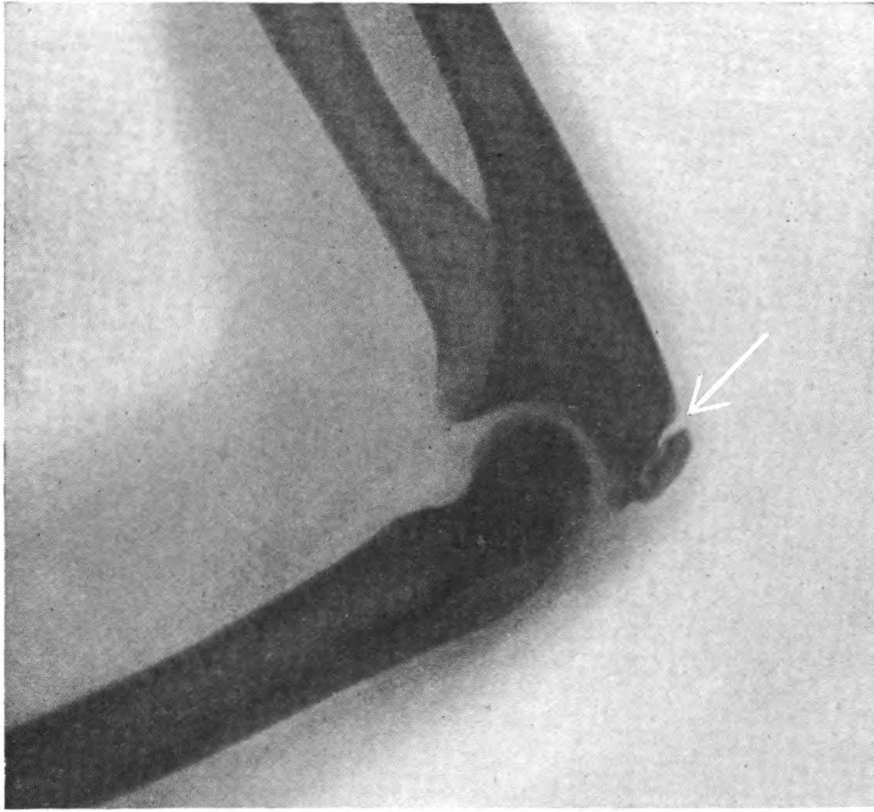

Fig. 67.—Campbell radiograph of elbow.

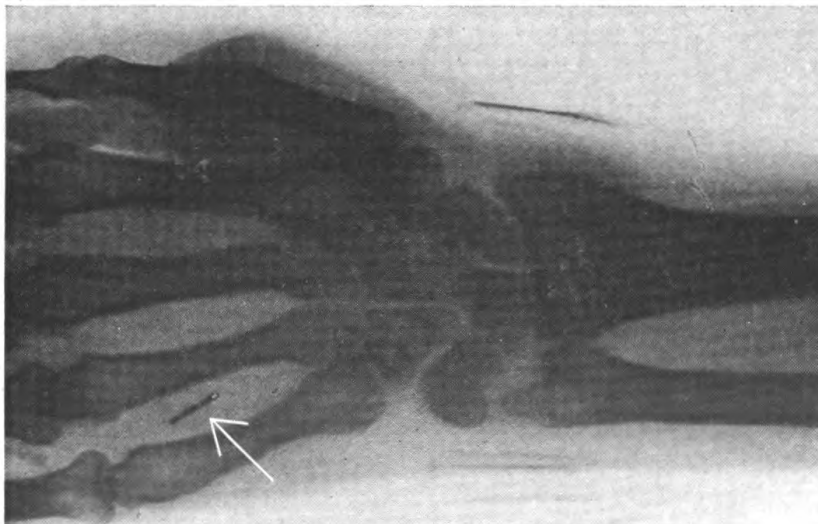

Fig. 68.—Campbell radiograph of hand.







Fig. 69.—Campbell radiograph of heel.



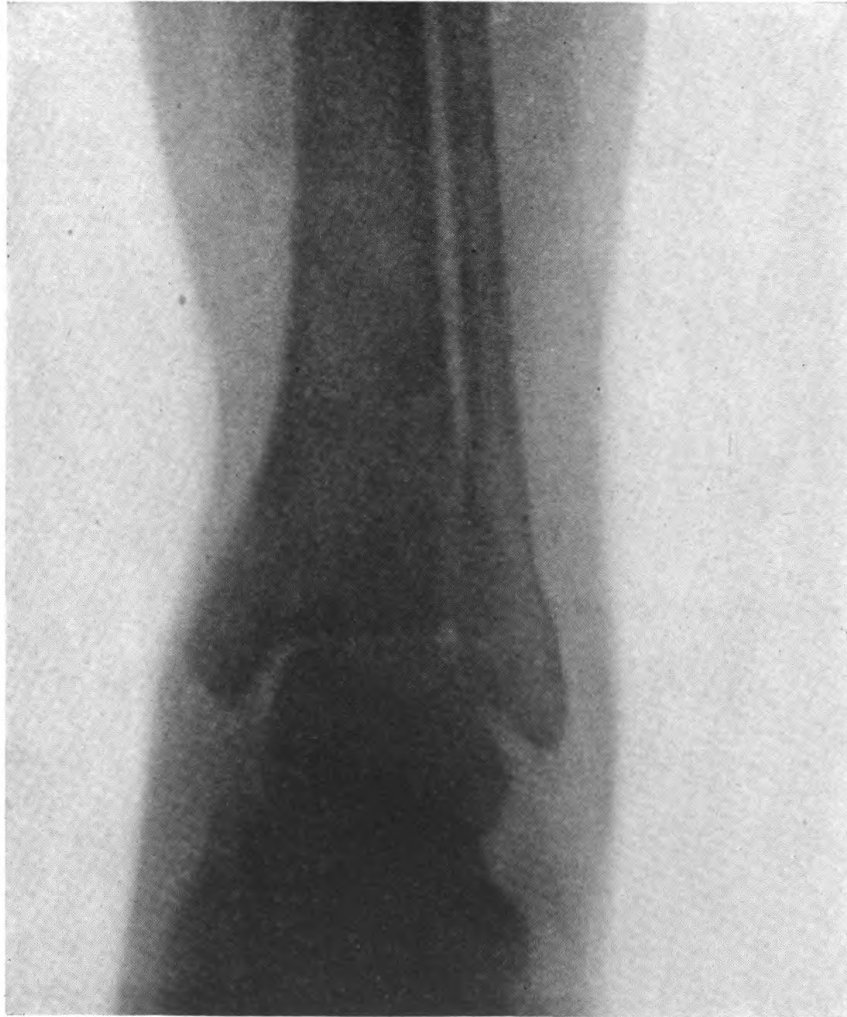

Fig. 70.—Campbell radiograph of wrist.



the X-ray tube and the fluoroscope, is placed in a wooden carrier no larger than a dress-suit case, and quite as portable. This small apparatus enables us to perform remarkable high frequency and X-ray work. The results obtainable are really wonderful. With this portable apparatus a rotary converter must be employed—where the direct current is used—to change the direct to an alternating current.

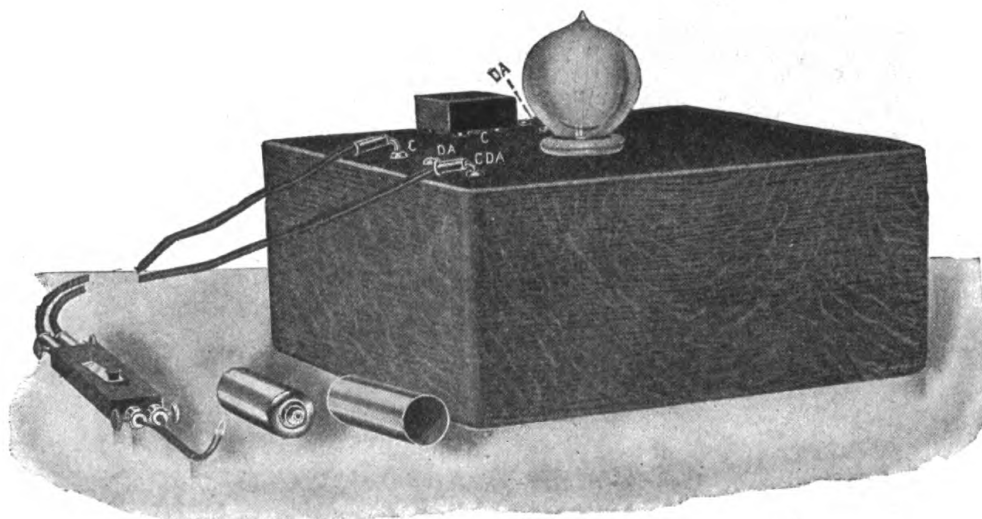

Fig. 72.—Campbell d'Arsonval attachment.

### GLASS VACUUM ELECTRODES.

In using high frequency currents we employ glass vacuum electrodes of different sizes and shapes, according to what part of the body is to be treated. If we connect one of these glass electrodes to the apparatus and then bring the hand near the electrode, we will notice a violet brush discharge which is produced by induction at the outer side of the glass. When we place this form of electrode in contact with the body, we at once perceive the sensation of heat; as we move the electrode farther from the skin we notice that the sparks become larger and more intense and change to a white color. We should avoid

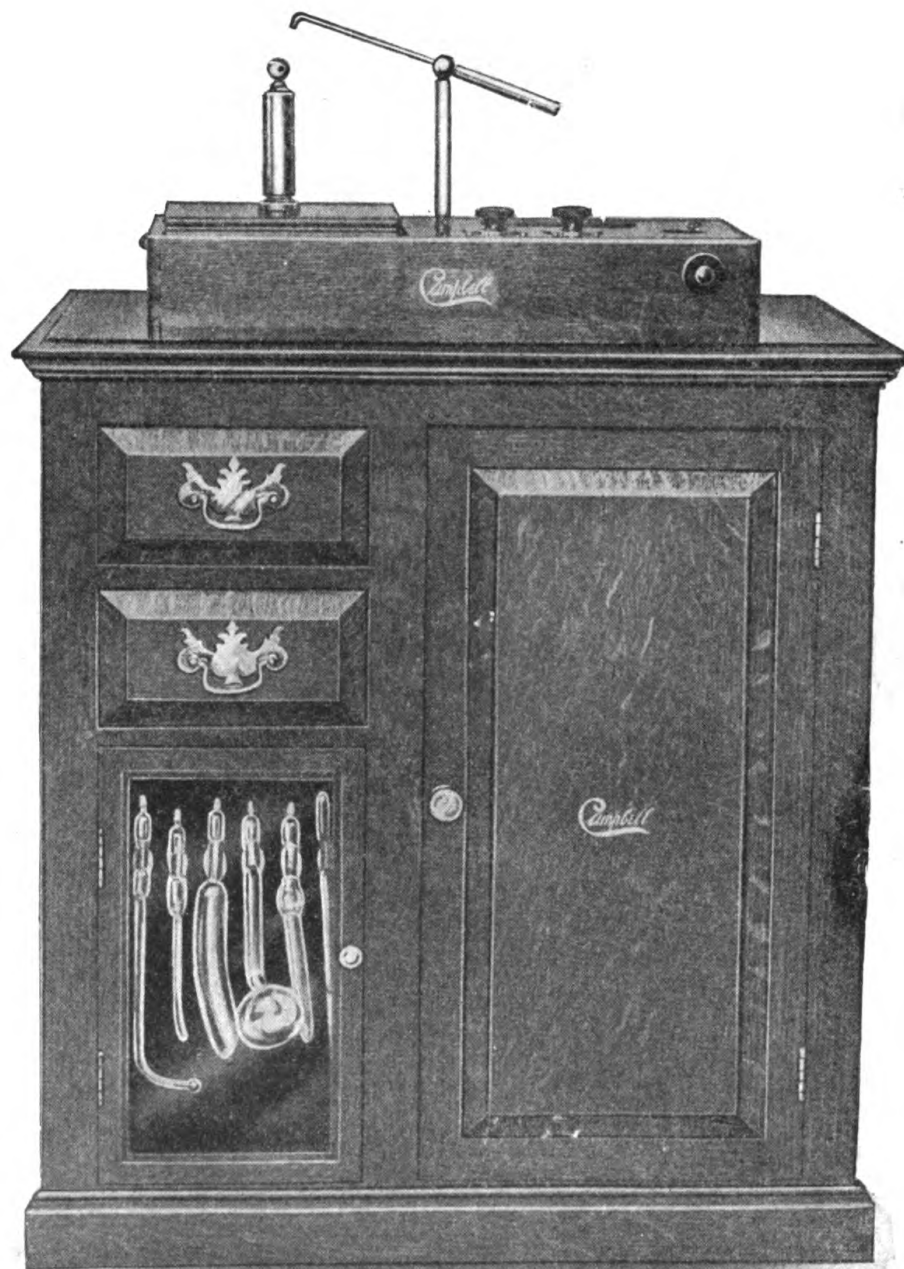

Fig. 73.—Campbell coil and cabinet.

these white sparks, as they may blister the skin very much. Excellent results are obtained from high frequency currents if a suitable glass vacuum electrode be applied directly to the mucous membrane of the nose, urethra, rectum, or vagina.

### APPLICATION OF HIGH FREQUENCY CURRENTS.

For some time it was said that these currents depended for their curative properties upon their psychical effect or upon the spectacular phenomenon. That the criticism is unfounded

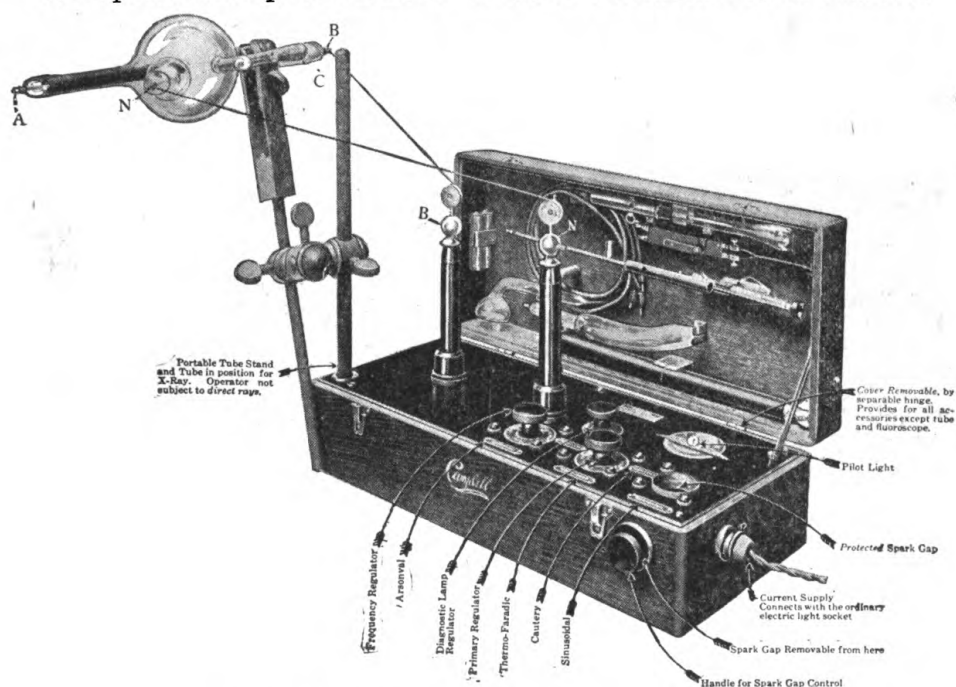

Fig. 74.—Campbell model "E" X-ray and coil.

goes without saying, the remarkable cures now obtained being sufficient proof of the true curative properties of these currents. The following are the principal methods of applying these currents:—

1. The direct method, by means of electrodes connected to the ends of the spiral.
2. Auto-conduction. In this method we have a wire spiral large enough to enclose the patient. It may be so arranged



that the patient may sit, recline, or stand. It is important to remember that, in this method, the patient does not in any way touch a conductor. The high frequency current traverses the spiral and thus inductively influences the patient. To show that we have currents of great magnitude we have but to have the patient illuminate an incandescent lamp by holding the lamp between his hands.

3. Auto-condensation. In this method the patient lies on a cushion, usually formed of a felt mattress having a uniform thickness of four or five inches and containing no metal. The cushion rests on a couch, on which is placed a metal sheet connected to one end of the spiral. The patient lies upon the

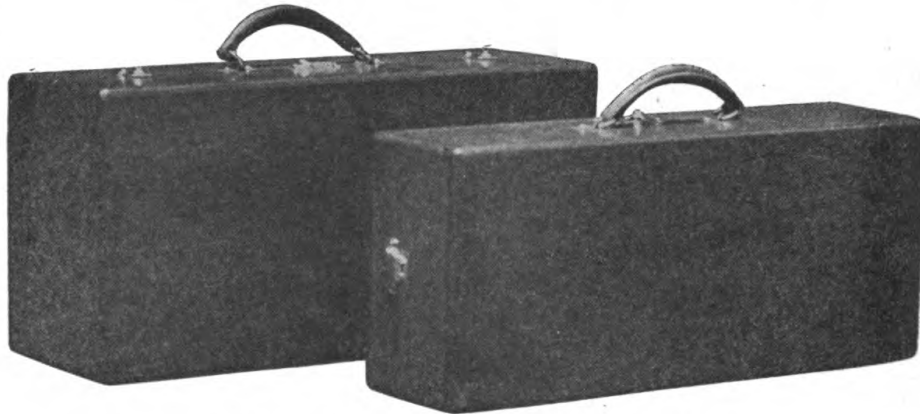

Fig. 75.—Campbell coil, ready for carrying.

cushion and so is near the plate, but does not touch it. The other end of the spiral is connected to the patient's hands by means of a bifurcated metal electrode. This is also known as the treatment by the "condensation couch."

Auto-condensation may now be given by means of the "auto-pad" manufactured by the Campbell Electric Co., of Lynn, Mass. This pad, though not much thicker than the cover of a book, is so perfectly insulated that a very heavy current of voltage sufficiently high to produce all the therapeutic effects obtained by the d'Arsonval method, may be used without fear of sparking the patients.

When we are using the "auto-pad" we should not turn on

the current until the patient is sitting on the pad and we should not allow the patient to attempt to rise while the current is turned on.

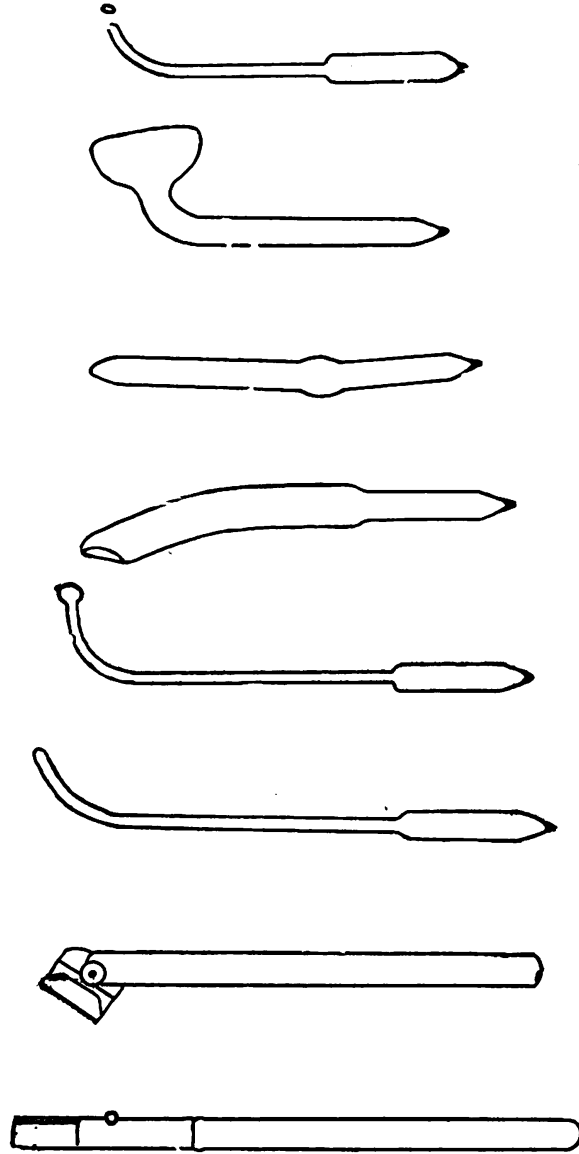

Fig. 76.—Campbell electrodes for high frequency.

Sometimes the patient thinks he is obtaining no electricity by means of this pad, as he will not feel the current. Such a patient may readily be convinced by directing him to arise from

the pad while the current is turned on, when he will at once receive sparks.

Here it may be well to utter a warning about using the "auto-pad," or the "condensation couch." We will soon learn that a patient, after "auto-condensation" treatment, will feel in a glow and perhaps be in a state of perspiration. We should not allow our patient to leave the reception room immediately after such treatment, especially during cold weather. A severe chill might be the result as soon as the street is reached.

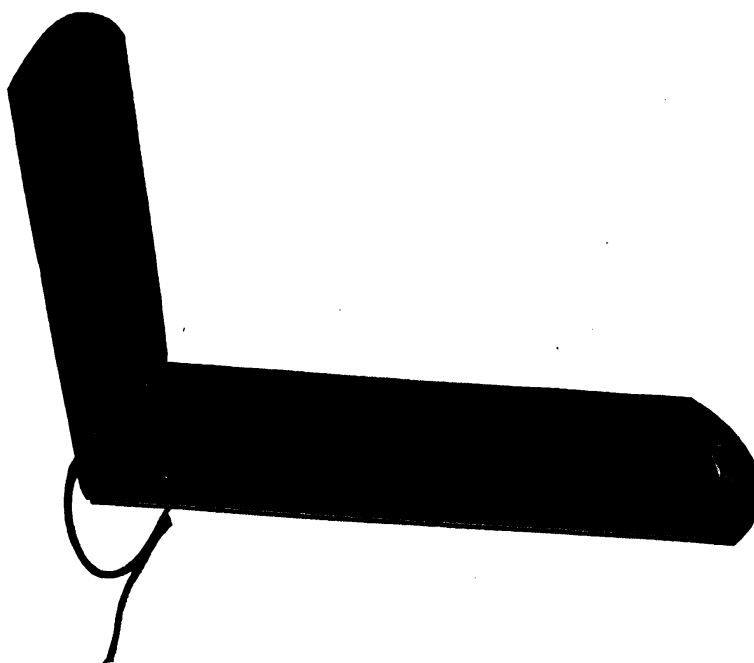

Fig. 77.—Campbell "auto-pad."

#### THE USES OF HIGH FREQUENCY CURRENTS.

It is difficult in a book of this size to describe all the cases that may be treated by these currents. The field of usefulness is very broad in as much as the action of the high frequency currents may be either local or general. We see the local action by the great ease with which we are enabled to relieve pain and remove local congestion. To obtain a rapid local action we should use the cataphoric electrode. We notice the general

action when treating cases of functional nervous diseases such as neurasthenia and hysteria.

It has been asserted that the results obtained by the use of the high frequency currents are purely psychic in nature. However, experience can leave no doubt as to the efficacy of the treatment. Besides, there is no psychic cure for the agonizing pain of a neuritis that has resisted ordinary treatment for months, and it is absurd to attempt the explanation of such a case by suggestion.

A physician who is constantly using high frequency currents will have brought to his mind, from watching the effect of the current on different patients, many new possibilities of application of this new form of current. The writer usually gives a general treatment to patients who come for local treatment only. If, for instance, he is treating the nerves of an arm, he always insists on the patient receiving short treatment over the head and spine. He finds this produces a general stimulation which helps very materially in curing the local condition. We should remember that, for a soothing effect, we are to use the glass vacuum electrode in direct contact with the skin. As we pass the electrode over the surface of the skin we should be careful to hold it pressed closely against the skin. This may seem a small matter but if we allow the electrode to spark the skin of a timid person, the latter may become alarmed and decline further treatment. This is especially true of nervous women and children.

The writer always takes the handle of the electrode in his left hand, turns on the current, places the bulb of the vacuum electrode against the skin of his right hand and then against the skin of his face. This reassures the patient. We should begin the treatment with a mild current in using the Campbell coil and increase the strength of the current by turning the spark-gap interrupter to the left (not clock-wise).

We will soon notice that a vacuum electrode which passes over the skin in direct contact will not produce a spark. If we pass this same electrode over and in direct contact with clothing, we will at once notice fine sparks making their appearance. This phenomenon is taken advantage of in treating ulceration

and chronic conditions, where we wish stimulation or counter-irritation.

In this method of treatment the writer applies several thicknesses of gauze and places the electrode against the upper layer. He often gives treatment to the spine by passing the electrode against the thin underclothing along the spine. Patients say, under these circumstances, that a light spark is felt, which is not at all unpleasant. We should use a mild current when we hold the electrode against the clothing and should be careful to keep the electrode in motion.

When we are using a strong current we must, under all circumstances, remember to keep the electrode moving continually, otherwise we may cause much pain and possibly a great deal of unnecessary local irritation. This is especially true in the use of the vacuum electrode in a cavity.

As would be expected from a general increase of circulation, we will notice a slight redness and an increased glow on the skin after a treatment. This is what we seek to bring about and the feeling of warmth is very grateful to the patient.

We should not be afraid of using too mild a current in the first few treatments, especially if the patients are women and children. Sometimes a timid patient will say that he does not feel any current during the treatment. In such a case the writer tells the patient that he does not want the latter to feel any current at that time but that later, when the patient becomes accustomed to the treatment, the strength of the current will gradually be increased without causing the patient any distress or annoyance. Much tact is often required to gain the confidence of the patient. It is important to impress on the patient's mind also the necessity of regularity of treatment. If we are to obtain good results from the high frequency currents, it is necessary that the treatments be given at regular intervals. We sometimes hear of persons who are taking an electrical treatment once or twice a month. Such a patient does not need electrical treatment at all. At least two séances a week should be insisted upon.

High frequency currents may be used in chronic eczema. ozena, obstinate ulcers, lupus vulgaris, pruritus ani, hemor-

rhoids, gonorrhoea, epilepsy, gout, rheumatism, rheumatoid arthritis, neuritis, tuberculosis, neuralgia, anemia, hysteria with high blood-pressure, obesity, and neurasthenia when there is high blood-pressure.

### DISEASES AND CONDITIONS IN WHICH HIGH FREQUENCY CURRENTS DO GOOD.

The writer has briefly summarized the application of the high frequency currents in the following affections arranged, for convenient reference, alphabetically.

**Acne.**—This affection may be treated by carrying the surface electrode for five minutes over the diseased area, with the electrode in contact with the skin. Then, holding a pointed electrode a short distance from the skin, we cause a spark to fall directly on each papule or pustule.

**Anal Fissure.**—High frequency currents have been recommended for the cure of this condition. However, we advise the patient to be treated by a rectal surgeon; later on we may use the high frequency currents by means of a rectal electrode, employing a mild current or one of medium strength, but not the spark as has at times been suggested.

**Arthritis Deformans and Rheumatoid Arthritis.**—Arthritis deformans and rheumatoid arthritis may be helped by using both local and general applications.

**Asthma.**—In the treatment of this affection high frequency currents have been recommended. The neurotic condition and the general health of the patient will be improved by the use of these currents; the method to be used is the d'Arsonval, which may be given by means of the "auto-pad" or the "condensation couch."

**Carcinoma.**—The writer is strongly of the opinion that electricity should never be used in treating carcinoma, except under the following circumstances: (1) when the surgeon declares the case to be inoperable; (2) after an operation. There is no question but that high frequency currents, both locally and generally, will be of great service in building up the general physical condition after the surgeon's work is ended.

While cures have been said to result from the use of high frequency currents and from X-ray treatment, we should not forget that in such cures there may be a large element of doubt as to whether the case in point is really one of cancer. Not every physician is able to tell from macroscopical examination that cancer is present.

If we treat cancer by electricity, we cannot possibly remove the adjacent lymph-glands. While we are applying electricity we are wasting valuable time. Everyone knows that such cases are properly surgical and also that the earlier the operation the more the chance for a recovery; procrastination may be fatal.

**Catarrh, Nasal.**—High frequency currents act very well here. Both local and general treatment should be given. In the local treatment we should employ the nasal vacuum electrode, with a very mild current for from two to five minutes. Beginning with a mild current we should place the electrode in our left hand and then place the hand on the patient's face. This procedure enables us to slide the electrode from the hand to the skin of the face without causing an unpleasant sensation. With a little further care we may introduce the electrode into the nostril without causing any spark to pass from the electrode to the mucous membrane of the nostril. We should be careful never to lift the electrode entirely from the skin or mucous membrane, for the breaking of contact will cause sparking—a highly important consideration to remember in giving nasal treatment.

Some physicians place the electrode in the nostril before turning on the current. This cannot be considered good technic since we may turn on too strong a current. We will inevitably alarm and distress the patient, especially if sparking ensues. We should not forget that a delicate mucous membrane will not bear so strong a current as will the palm of the hand.

By holding the fingers of the left hand on the electrode about two or three inches from the nostril we will find that we are enabled to regulate the strength of current more or less. If we will use a nasal vacuum electrode, and, after turning on a mild current, run our fingers up and down the electrode near its end, we will soon see how the current may be regulated.

**Ozena and Atrophic Rhinitis.**—Ozena and atrophic rhinitis both show remarkable results following the use of the high frequency treatment with a nasal vacuum electrode. Both the odor and the discharge are relieved.

**Chlorosis.**—This condition may be greatly helped by giving general treatment by means of the vacuum electrode and also "auto-condensation" by means of the "auto-pad" or the "condensation-couch." Medical treatment should of course also be employed.

**Constipation.**—In this condition, we should use "auto-condensation," high frequency applications to the abdomen, and, in obstinate cases of constipation, the insulated rectal electrode.

**Deafness.**—This affliction, if due to a catarrhal condition, is said has been helped by applying a small high frequency electrode to each ear for a few minutes, and then by giving "auto-condensation" treatment for twenty minutes. The value of this treatment is seriously open to question unless perhaps the case be one of very recent origin.

**Diabetes.**—In this disease high frequency treatment has been credited with cures. This the writer does not accept. However, a patient's condition may be markedly improved by using the high frequency current in a general manner, *e.g.*, by means of the "auto-pad."

**Diagnosis.**—Of course, in diagnosing fractures and dislocations, the use of the X-ray tube is well-nigh indispensable. As is well-known, most unexpected results are sometimes met with. The writer once saw a radiograph, taken by means of a Campbell X-ray apparatus, in which, together with a fracture, there was shown a needle imbedded in the flesh. The patient was wholly unaware that a needle had entered her hand, and thus was very much surprised when shown the radiograph.

**Dyspepsia.**—This trouble may be greatly relieved and even cured by general dietetic measures, combined with high frequency treatments. We should administer general treatment, by means of the "auto-pad," and follow this by local treatment by means of applications over the region of the stomach, using the surface electrode. Constipation, which is often present, may be treated as indicated under that heading.



**Eczema.**—We should employ general treatment, followed by the use of the surface electrode on the affected area. X-ray treatment has also been extensively employed in conjunction with the high frequency currents. Many, many cures have been reported in cases of eczema treated by the high frequency currents. We should not prolong the treatment too much at one sitting, and we should be careful not to attempt too much at a time.

**Gleet.**—Excellent results have been obtained from the use of high frequency currents in gleet. We should employ a mild current by means of an urethral electrode for five minutes; we should then use a rectal electrode for three minutes; this should be followed by the surface electrode over the perineum for two minutes. The surface electrodes must, of course, be kept moving.

**Goitre.**—We should use mild high frequency treatment with the surface electrode for five minutes, and follow with a general treatment for ten minutes. Excellent results have followed this treatment of goitre. Cataphoresis may also be used. The cases should be carefully selected; many cases of goitre should be referred to the surgeon.

**Goitre, Exophthalmic.**—Local high frequency applications also yield good results in this affection. A treatment should last five minutes and should be followed by general treatment for eight minutes. Of course, general medication should also be employed.

**Gout.**—Local treatment by means of high frequency currents affords here also very gratifying results. The treatment should be given daily and a very mild current should be used. "Auto-condensation" is to be used three times a week. We *should* employ high frequency currents during the acute exacerbation; but the local treatment should be very judiciously given and a very mild current employed.

**Headaches.**—A mild high frequency current, over the affected area and along the cervical vertebræ, very often yields excellent results, sometimes giving immediate relief. Of course, we must seek the cause of the headache and also treat it by general medical principles.

**Hemorrhoids.**—We should here employ general treatment for ten minutes, and follow with local treatment by means of the vacuum rectal electrode for five minutes. Applications should be given daily at first. We should treat constipation, if present. It should be needless to observe that some cases of hemorrhoids should be at once referred to the rectal surgeon for operation.

**Hysteria.**—A large amount of time and space has been devoted to describing the wonderful cures that have been obtained from the use of high frequency currents in the treatment of hysteria. As a matter of fact, very few cases of hysteria should be treated by means of this form of current. A low blood-pressure is usually present in cases of hysteria. High frequency currents tend to lower blood-pressure still more and this fact must not be lost sight of. Static electricity, which raises blood-pressure, is really the proper modality to employ. Some physicians employ high frequency currents in hysteria for the psychic effect. The static machine will produce all the psychic effect needed, together with the proper effect on blood-pressure.

**Indigestion.**—The writer has obtained good results, in some cases, from the very first application in this condition. We should give local treatment over the region of the stomach for five minutes, keeping the surface electrode moving continuously. The "auto-pad" should be used for ten minutes. The treatment should take place every day at first. Constipation, if present, should be treated and the diet regulated. It is particularly in atonic conditions that this method is adapted.

**Indigestion, Intestinal.**—Here the treatment is the same except that the surface electrode is carried over the abdominal region for ten minutes. We should use the "auto-pad" for ten minutes.

**Insomnia.**—Very remarkable results have been obtained by the use of this modality in the treatment of insomnia. By means of high frequency treatment, we are enabled to produce a sleep which closely resembles natural sleep. We see none of the headache, nervousness, constipation, and digestive disturbances which follow the use of sleep-producing drugs. The

sleep produced by high frequency treatment is sound and refreshing. Furthermore, it is a fact that high frequency currents will often induce sleep when drugs fail. The method employed is to use the "auto-pad" for twenty minutes and follow with the surface electrode over the head and down the spine for ten minutes.

**Laryngitis, Chronic.**—We should employ a mild current by means of the vacuum electrode especially designed for throat work. The applications should not be too prolonged, otherwise an increase of the inflammation may result. Applications of from three to five minutes will suffice. Three treatments each week should be ample.

**Leucorrhœa.**—We should use the vaginal vacuum electrode for but three minutes for the first few days. We should insist on daily treatment. The time of treatment should gradually be increased from three to ten minutes. We should always employ a mild current at first, so as not to alarm our patient. General treatment will aid in obtaining a cure.

**Locomotor Ataxia.**—Cures have been claimed in this disease from the use of high frequency currents. This, of course, is not true. It is very important to remember that some cases of hysteria greatly resemble locomotor ataxia. These cases of hysteria, simulating locomotor ataxia, are really the cases cured by electricity. High frequency currents can, however, relieve pain to a great extent, thus rendering unnecessary the use of opiates. The gastric crises and the lancinating pains are helped very much by this modality. We should give local treatment over the painful area for five minutes and then employ general treatment for ten minutes. The high frequency treatment, with the Fränkel treatment for incoördination, gives us great hope for the poor victim of this disease. By means of these two methods, a patient may live a fairly useful life even though he will *not* obtain a radical cure.

**Lumbago.**—Local and general treatments with high frequency currents are of decided benefit. Many cases are promptly relieved.

**Moles.**—We should use a small pointed vacuum electrode and continue the treatment until blanching is noticed. We may employ cocaine if much pain be present during the treatment.

**Neuralgia.**—We should use local treatment by means of a vacuum surface electrode and follow this with “auto-condensation” for ten minutes. We should administer treatments daily at first, and then every second day until the case is cured.

**Neurasthenia.**—We use the d’Arsonval method with the “auto-pad” or the “condensation couch.” Treatment by means of the surface vacuum electrode over the head and neck and down the spine helps greatly in this distressing condition. The remarks about blood-pressure, in discussing the treatment of hysteria, apply with equal force here.

**Neuritis.**—In this condition high frequency treatment may be considered almost a specific. It is wonderful what may be accomplished by means of high frequency currents, especially in those cases that have resisted such treatment as bandaging, blistering, application of iodine, and galvanic and faradic electricity. Sometimes a case is met with in which the pain has resisted even opiates and has greatly interfered with sleep; in such cases high frequency treatment is followed by almost immediate relief. If we suspect any rheumatic tendency in a case of neuritis, we should, of course, prescribe internal medication for this condition. Of course, the more recent a case of neuritis is, the earlier we may look for a cure. We should not forget, however, that sometimes a case of neuritis may be prolonged because of an underlying rheumatism.

**Rheumatism, Acute.**—We should use a surface vacuum electrode over the affected area for ten minutes. Then we should use the “auto-pad” for ten minutes. Excellent results will follow the employment of high frequency currents in the insomnia, anemia, and muscular atrophy caused by rheumatism.

**Sciatica.**—We should use the surface vacuum electrode for ten minutes and the “auto-pad” for the same length of time. Treatments should be given daily. Treatment should be directed, of course, to the sciatic notch and the course of the nerve.

**Stomach.**—Pain associated with functional conditions in the region of the stomach usually disappear after a few treatments with high frequency currents. We employ the surface vacuum electrode on the bare skin over the stomach for ten

minutes, and follow this with the "auto-pad" for the same length of time. Any digestive errors that may be present should be corrected. We should not forget, of course, that the pain may be due to cancer or to a gastric ulcer and should in such cases act accordingly.

**Sycosis.**—We use the surface vacuum electrode for ten minutes.

**Torticollis.**—We use the surface vacuum electrode over the neck and shoulder for ten minutes, applying the current daily. We also give general treatment for ten minutes by means of the "auto-pad."

**Trachoma.**—We employ general treatment with the "auto-pad" for ten minutes and then use the eye vacuum electrode with a very mild current for five minutes. The treatment should be given daily.

**Tubercular Glands.**—We use the surface vacuum electrode for ten minutes, followed by the use of the "auto-pad" for ten minutes. The cataphoric vacuum electrode may be applied on the gland, using some preparation of iodine.

**Tubercular areas in the lungs** are said to be helped very much by surface vacuum electrode treatment for five minutes. This is very doubtful. If we employ these currents in this affection we should keep the electrode moving. We follow this with general treatment for eight minutes. However, high frequency currents may be used in tuberculosis to cause improvement in weight and to help the appetite and digestion. It is said that even elevations of temperature are favorably influenced and that even the number of the tubercle bacilli becomes less in the sputum.

**Ulcers.**—Indolent, rodent and syphilitic ulcers are helped very much by high frequency treatments. We utilize a surface vacuum electrode, placed on several layers of gauze. By this method the patient also derives the benefit of the ozone developed. In varicose ulcers we may of course also employ the Röntgen ray therapy.

**Uterine Diseases.**—All neurotic conditions are helped greatly by general treatment by means of the "auto-pad." Local

treatment by means of a special uterine vacuum electrode is recommended in cases of erosions and of endometritis.

**Warts.**—We should use a pointed vacuum electrode. If irritation be caused we should not administer the next treatment until all irritation has disappeared. See article under “Fulguration” (in the Appendix).

**Writer’s Cramp.**—This very annoying and troublesome condition will be helped very much if we will use local treatment by means of the surface electrode for ten minutes every day. The writer has seen most remarkable results follow this local treatment when the Fränkel method was used at the same time. We will find a great loss of coördination in some cases of writer’s cramp.

## CHAPTER XI.

### THERMO-ELECTRICITY.

---

PROFESSOR SEEBECK, of Berlin, accidentally discovered in the year 1822, the principle of thermo-electricity.

If the ends of a copper wire are connected with a galvanometer we shall see a deflection of the needle as soon as the wire is heated. This proves that heating the copper wire produces electricity. If we solder a bar of antimony to a bar of bismuth and join the free ends by means of a wire, we will obtain a current of electricity as soon as the solder is heated, and a current of an opposite direction as soon as the solder cools. Now, if we join a number of these couples, by means of wires, so that a bar of bismuth alternates with a bar of antimony, we shall have a thermopile or thermo-electric generator. The current derived from this is called thermo-electricity. It is now known that we can arrange the different metals so as to produce an electro-motive series which will conform to the laws governing a galvanic series. The metals should be arranged in the following order—taking antimony as the positive and bismuth as the negative end of the series: Antimony, iron, zinc, silver, gold, lead, mercury, copper, platinum, and bismuth. As in the galvanic series, the farther removed two metals are on this list, the greater will be the electro-motive force. If we solder the bar of antimony to the bar of bismuth and heat the soldered part, we will get a current of electricity which flows from the bismuth to the antimony and a reverse flow when the soldered part cools. The strength of the current is greater, the greater the difference of the temperature of the two metals and also greater according to the degree of temperature of each metal. Noë of Vienna has invented a very practical thermopile. The heat is furnished by means of a Bunsen burner. We are enabled to get about four ampères of current with this thermopile of thirty couples.

## CHAPTER XII.

### HYDRO-ELECTRIC BATHS.

---

THE hydro-electric bath is now very often employed in giving general galvanization, faradization, galvano-faradization, and general sinusoidal treatment. The bath is very useful when we have to treat weak, timid, and nervous persons. We may use either a mono- or a di-polar bath. In using the hydro-electric bath it is well to remember that the water is the electrode by which the current is applied to the body. In a mono-polar bath we use the wall of a metal tub as the large positive electrode, while a bar of iron, covered with wet chamois skin and held in both hands, is the negative electrode.

The current enters the water from the wall of the tub, which constitutes the positive electrode, comes in contact with every part of the body covered by the water, and then passes out by means of the iron bar, which is the negative electrode.

The patient's body should not touch the wall of the tub; this is prevented by having a perforated wooden lining on which the patient rests. An even cheaper method is to use a wooden tub with a very large electrode attached to the side of the tub and covered by the water. The use of the bar of iron held in the hands is not a very good method; too much electricity is concentrated at the hands and too little over the surface of the body.

In the di-polar bath the patient's body does not come in contact with either electrode, both electrodes being immersed in the water, one at either end of the tub. We should be sure the electrodes are covered with water and that neither of them is in contact with the patient. We should not turn on the current until the patient is in the bath. The apparatus for controlling the current should, of course, be in the bath-room.



It is worthy of remark that, while we should regulate the temperature of the water to suit the patient and according to well-known hydro-therapeutic principles, warm water is a better conductor of electricity than is cold water. The temperature of the bath should be from 90 to 98.6° F. We should not put salt into the water; any saline solution increases the conductivity of the water, and so carries the current past the body. A thirty minute bath is sufficient.

To give a faradic bath, we should regulate the amount of current according to the sensation of our patient.

To give a galvanic bath, we should use a milliampèremeter and gradually increase the strength of current up to 125 milliampères.

The faradic bath stimulates the patient and improves general nutrition.

The galvanic bath produces drowsiness and fatigue and so is useful in insomnia. The combined, or galvano-faradic bath, may be used to produce all the effects named above.

We should remember that the hydro-electric bath will have a sedative or stimulating effect on the general nervous system, according to which form of electricity is employed, and will also increase the activity of the skin. Stimulation of the sensory cutaneous nerves is obtained if the current be made strong enough.

The following table gives the proper temperature—to be ascertained by means of a bath thermometer—of different baths:—

Hot Bath—	100 to 110	degrees,	Fahrenheit.
Warm Bath—	90 to 100	“	“
Tepid Bath—	80 to 90	“	“
Cool Bath—	65 to 80	“	“
Cold Bath—	40 to 65	“	“

## CHAPTER XIII.

### MAGNETISM.

---

It seems remarkable that, in this enlightened age, so much time has been devoted to the study of electricity in medicine and that so little time has been expended on the effects of magnetism on the human body. These forces—electricity and magnetism—may be considered as twin-sisters. The relation between electricity and magnetic lines of force may be better understood by considering electricity as magnetism concentrated and magnetism as electricity diffused. Magnetism was known and its curative powers somewhat understood as early as 500 B.C.

Ampère's theory is that the phenomena of magnetism are due to the presence of electric currents in the atoms of substances that are capable of being magnetized. Maxwell's theory is that light and magnetism are produced by motion of ether waves. It is supposed that light is produced by oscillations, and electricity and magnetism by rotary motion.

A magnetic field of lines of force is the space surrounding any magnet or electro-magnet in which its magnetic force can be detected. Faraday studied this form of energy and found that these lines of magnetic force fly outward in curved lines from the surface of the generator at either pole and, whether the curve be large or small, eventually re-enter the generator at the other end.

The theory now advanced by Bachelet is that, by treating a patient by means of the magnetic wave-current, the electric potential of the human body is raised and the magnetism finally is transformed into vital energy, and so utilized in the vital processes. This seems to have been proved conclusively by Bachelet's experiments on the lower animals, the current energy being measured by a special form of galvanometer. After sub-

(147)

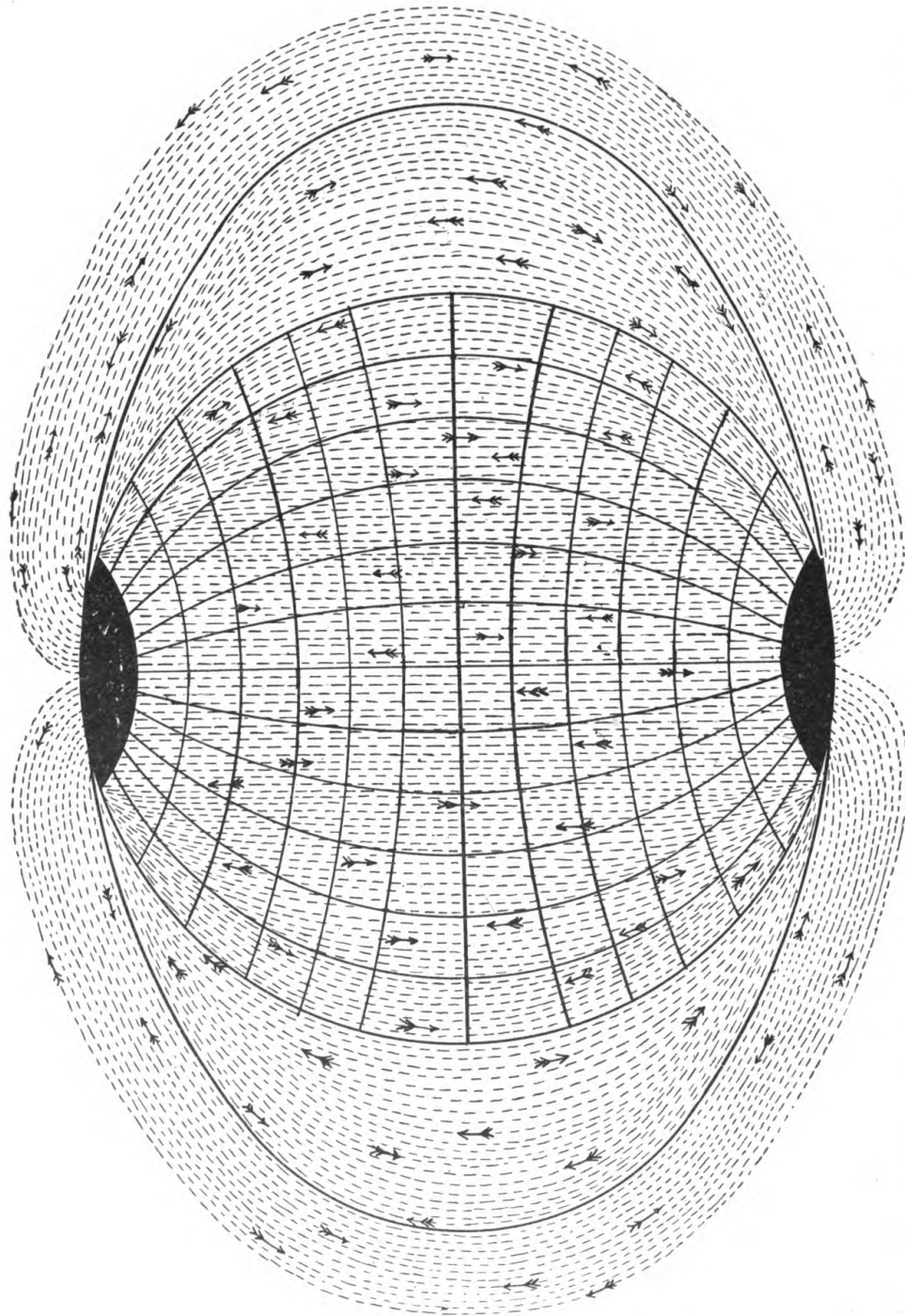

Fig. 78.—Diagram showing magnetic lines of force, also inner and outer sphere of magnetic field around the earth.

jecting the animals to charges of electricity and then to magnetic radiation, the following conclusions were arrived at:—

(a) *Electric currents* do not increase the electric potential of the living body.

(b) That, by placing a living body in a magnetic field and permeating it with magnetic lines of force to the maximum of exposure, the electric potential was raised as high as thirty-three per cent.

(c) That the energy thus imparted to the living body did not depart but was transformed into vital energy and used in the vital processes.

(d) That, according to the average established by a series of experiments, the electric potential of the living body, twenty-four hours after its storage with magnetism, showed an augmentation of twenty-five per cent. above normal.

(e) That the augmentation, forty-eight hours after storage, remained on the average at nineteen per cent.

(f) That, on the average, seventy-two hours elapsed before the stored energy was finally absorbed and the body returned to its normal potential.

We hear very little concerning the use of magnetism in medicine. A careful search of medical literature will not give us much information concerning it.

Baron von Reichenbach, sixty years ago, said in his book: "This, therefore, has been the melancholy history of magnetism. During ages repeatedly taken up and laid aside again, it now lies, almost unused. So remarkable, so profoundly efficient—nay, one may say, an incomparable means of allaying suffering where the human hand is so seldom capable of affording help. At a not far distant time I confidently hope this will not be. Henceforth the all-powerful influence of terrestrial magnetism will be estimated and taken into account, and the whole question of magnetism will be subjected to regular study in its relation to medicine; progress will be made and a clear understanding arrived at. The world will at length be able to hope for healing powers to be drawn from these extraordinary things, whence it has so long justly expected them."

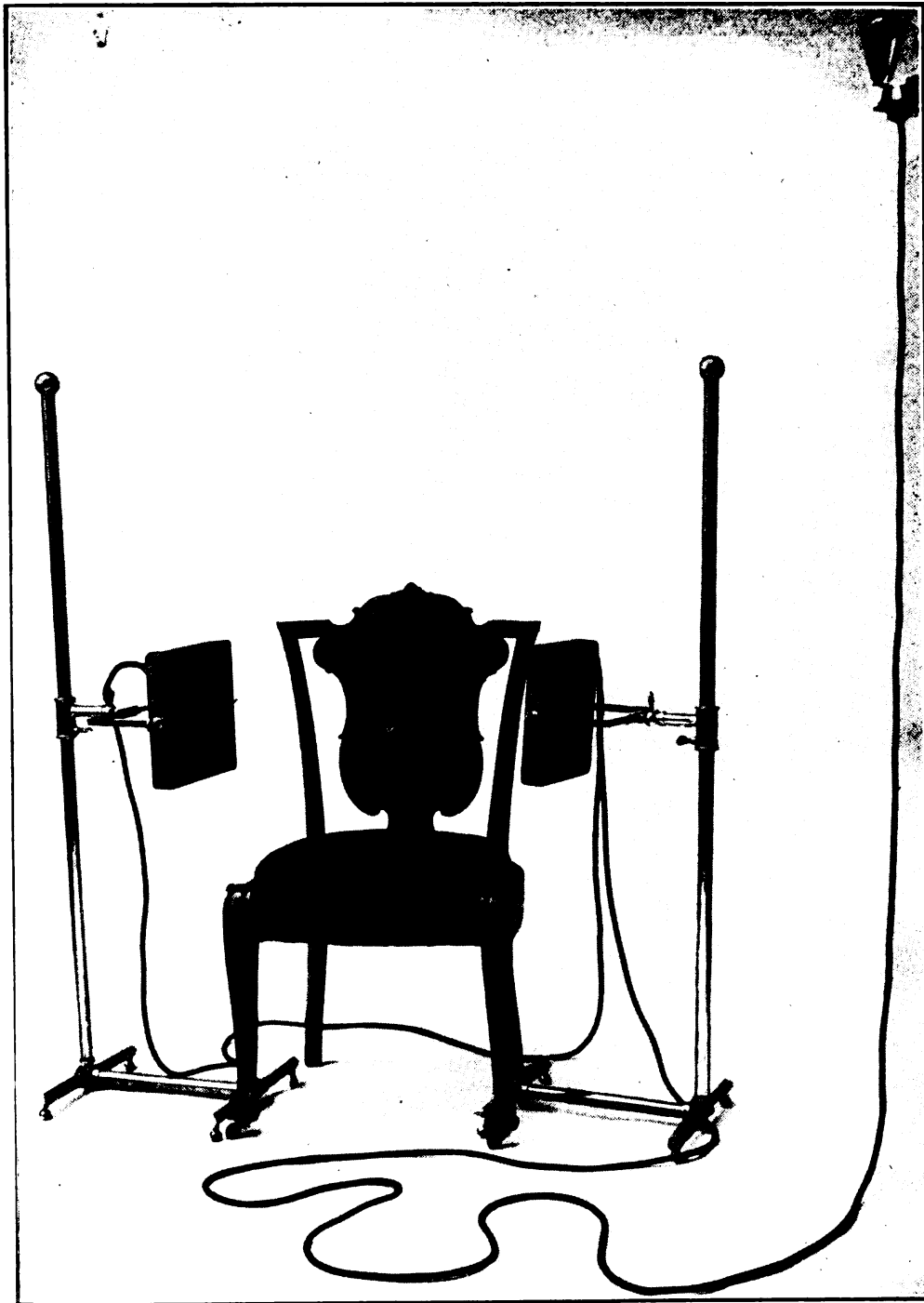

Fig. 79.—Bachelet alternating generators.



Fig. 80.—Bachelet direct current and transformer.

The real reason why magnetism has not been used in medicine seems to be that there was no apparatus which would furnish the magnetism.

### MAGNETIC WAVE GENERATORS.

Emile Bachelet took up this study and devoted fifteen years to the perfection of an apparatus. His first invention was a crude and cumbersome machine, weighing six hundred pounds. He now has two inventions, one for use with the Edison current, and the other for use where no street-current is available; in this latter form, a dry-cell battery is used in place of the street-current. He has called his apparatus "Magnetic Wave Generators."

It has been said that compensation is the law of life. If this be so, is it not possible that the human body has to pay the price of living in steel and fireproof buildings by having the magnetic lines of force taken from our bodies eaten up—as it were—by these steel buildings and passed back to the earth?

**Description of the Bachelet Generators.**—This apparatus consists of two co-acting magnets placed opposite each other and energized by the street current, or by dry cells. The large alternating current machine when energized with the 110 volt, 3 ampère current, shows by electrical measurement, 100 volts and 800 milliampères in the inner sphere.

The large direct current machine when energized with the 110 volt, 3 ampère current shows by electrical measurement 100 volts and 800 milliampères in the inner sphere. A rotary converter is used with the direct current machine.

The small alternating machine, when energized with the 110 volt, one ampère current, shows 100 volts and 200 milliampères in the inner sphere.

The dry-cell or battery machine shows about 200 milliampères in the former sphere, but the voltage depends upon the cells used. This dry-cell machine is for use in an office not equipped with the Edison current. It is not so strong as is the type of machine energized by the street-current. It is claimed that the same results may be obtained from this small machine if the treatment be continued from two to four hours instead of



Fig. 81.—Bachelet dry-cell generators.



from one-half to one hour, as is recommended in using the larger apparatus.

**Method of Treatment.**—The magnets may be adjusted at either side of a chair, couch, or bed. The patient is placed between the magnets and the current turned on. If full strength is desired, place the magnets close to the patient's body, if we are treating a child or a timid person, place each magnet about eighteen inches from the patient's body. In acute cases, the treatment should last for one-half hour; in chronic cases, the time should be extended to from one to two hours. We will find that as a rule, three treatments a week will be sufficient to keep the patient's body full charged. The magnets are usually placed opposite the site of the disease, but this is not absolutely necessary. The patient's clothing need not be removed.

We should remember that the wave dilates the blood-vessels and we should never allow our patient to venture out in cold weather for at least ten minutes after the treatment has been completed.

No insulation is necessary, and no shock of any kind is experienced by the patient.

**Action of the Magnetic Wave.**—The magnetic wave is a sedative and antispasmodic; it promotes secretion and excretion; it inhibits a too rapid pulse and lowers high blood-pressure; it quiets restlessness to a remarkable degree, and benefits insomnia.

#### DISEASES TREATED BY THE MAGNETIC WAVE.

Anemia, arteriosclerosis, chorea, convulsions, hiccough (especially the hysterical form), hysteria (with high blood-pressure), insomnia, melancholia, migraine, neuralgias, neurasthenia, neuritis, nervousness, rheumatism and tremors are among the affections in which this form of treatment has been followed with benefit.

Careful blood examinations have been made which show that, under the magnetic wave treatment, there had been found in several cases an increase in the number of red cells, together with an increase in the percentage of hemoglobin.

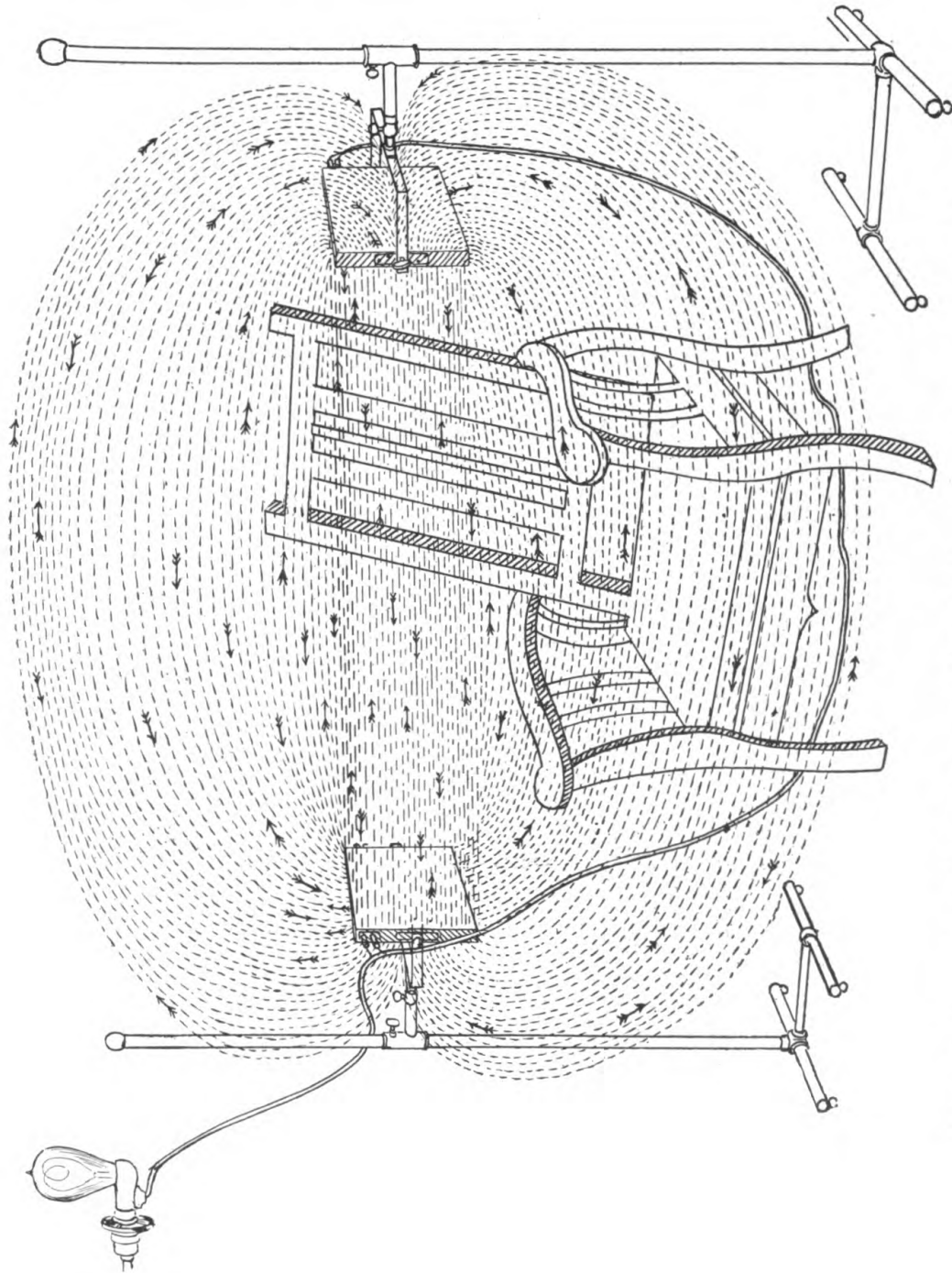

Fig. 82.—Generators showing the working of the co-acting magnetic lines of force.

With the Bachelet magnetic wave-machine there is furnished an apparatus known as a "detector." To this may be attached a small incandescent lamp, which will be lighted as soon as the detector is placed in the magnetic field near either of the magnets. If a small telephone receiver be attached to the detector, and the detector placed anywhere in the magnetic field, we should at once hear a sound which grows louder the nearer we approach either magnet. The sound should be heard at any part of the space between the magnets. If at any point we do not hear the sound, we will at once know that we have a space known as "a dead-centre;" if we find a "dead-centre" we are to remember that we have not connected our apparatus properly and our patient will not receive the proper treatment. The real object of the "detector" is to show to the physician that no "dead-centre" is present.

Sometimes patients become skeptical and say that they do not feel or see the magnetism. In such cases we may use the detector with the small electric lamp, the telephone receiver, and also two metal hand electrodes and thus let the patient see, hear, and feel the electricity as it comes through the detector placed in the magnetic field.

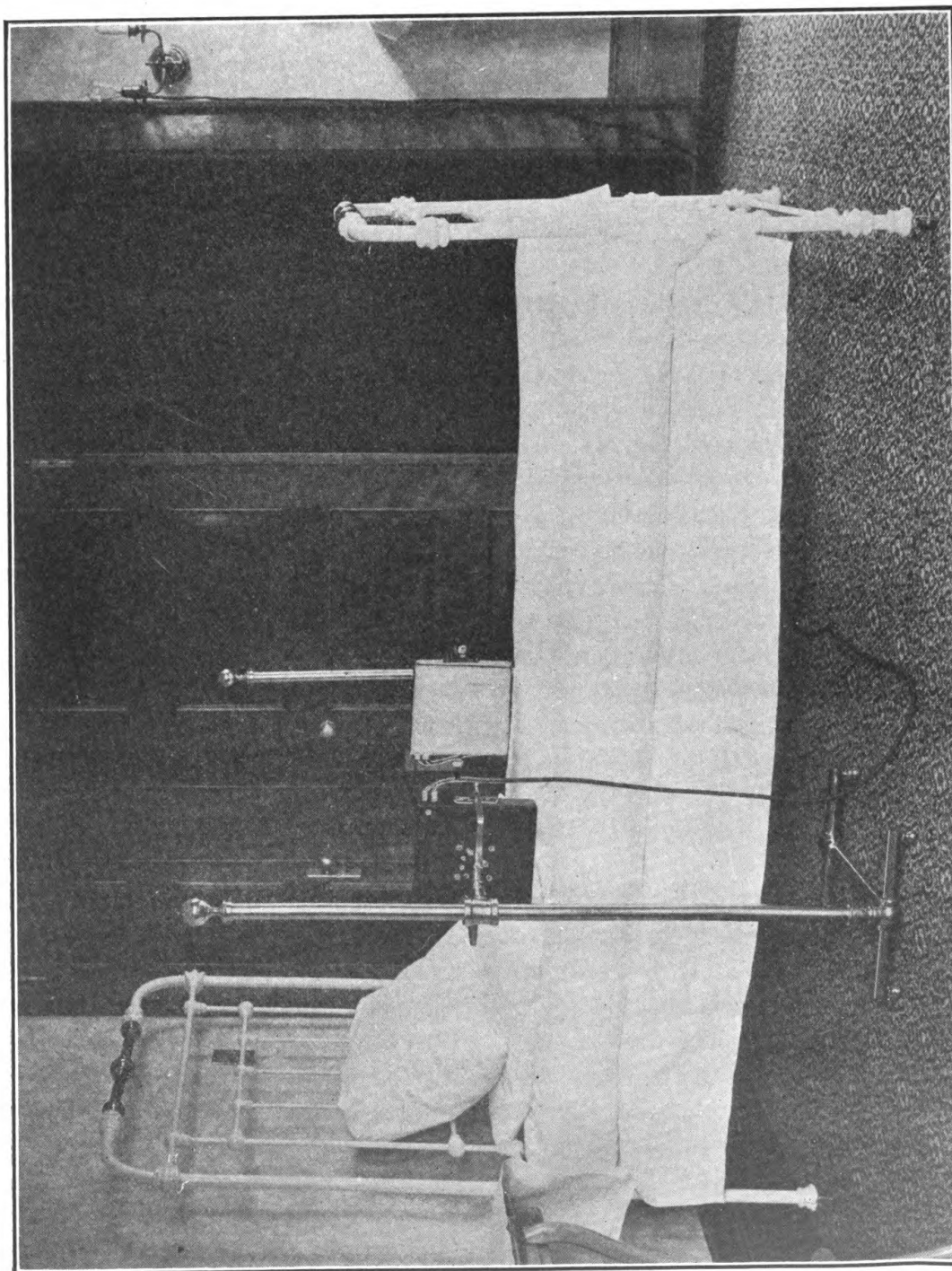

Fig. 83.—Bachelet generators in use in sick room.

## CHAPTER XIV.

### SPECIAL THERAPEUTICS.

---

IN applying electricity in the treatment of disease it is essential that we understand what form of electricity is indicated and know how long to continue a sitting. The treatment in vogue some years ago may soon become quite obsolete because of the advent of the newer forms of electricity, *i.e.*, the sinusoidal, the high frequency, and the magnetic wave treatment.

If we wish to counteract the effects of mental overwork we use the galvanic current, placing the cathode on the forehead and the anode at the nape of the neck; to relieve congestion of the brain we simply reverse our polarity. A person with high arterial tension should be treated—as has already been said—with high frequency currents, as these currents have the property of lowering blood-pressure; a patient with low blood-pressure should be treated with static charging, which raises blood-pressure.

The following affections are briefly considered in alphabetical order.

**Abscess of Brain.**—All that need be said is that we should not waste valuable time in treating abscess of the brain, tumors and inflammatory conditions, by means of electricity. Headache and dizziness, due to arteriosclerosis, may be helped by means of the high frequency currents—as these currents relieve high blood-pressure—notwithstanding the advice usually given in text-books that electricity should never be used in the treatment of headache due to arteriosclerosis.

**Anesthesia.**—If the anesthesia be due to a peripheral cause, we use faradic brushing; we should not expect good results from the use of electricity if the anesthesia is due to a central disorder.

**Cerebral Diseases.**—Usually the induction coil is not well borne, so we should use the galvanic current and be very careful not to have any sudden change in the amount of current strength. It has been said that electricity does no good and may do much harm in treating cerebral diseases. This is true only when the current is applied by unskilled or careless persons.

**Chorea.**—Sparks drawn from the spine and affected side by means of the static machine usually give excellent results in chorea. The sinusoidal current sometimes helps greatly. We should not employ the interrupted galvanic or the faradic current; if we use galvanism at all we should use the constant current. It will be better to depend on medicinal treatment and rest in bed. High frequency, both local and general treatments, will be of benefit. Excellent results follow the Bachelet magnetic treatment.

**Exophthalmic Goitre.**—There can be no doubt that electricity helps very materially in this neurosis, even though a permanent cure is not obtained. We find that under treatment there is a lowering of the pulse-rate from 10 to 20 beats and often an actual decrease in the size of the gland.

The three theories advanced as the cause of exophthalmic goitre are: (1) hematogenic; (2) neurogenic; (3) thyreogenic. If we believe that the neurogenic theory is correct, we are justified in treating exophthalmic goitre by means of some form of electricity. If we believe that hysteria and neurasthenia have much to do with exophthalmic goitre—and it is a theory frequently advanced—we should use that form of electricity usually employed in neurasthenic states. In using the galvanic current in this affection we apply the anode at the nape of the neck and a bifurcated cathode at either side of the thyroid gland. Three milliampères should be employed, for from 5 to 10 minutes. These applications should be made twice daily for months.

If high blood-pressure be present the high frequency current may be employed to reduce the blood-pressure. It is important to remark that, while the ordinary resistance of the human body is from 4000 to 5000 ohms with a current of 15 volts, the resistance in exophthalmic goitre ranges from 500 to 1500 ohms with the same strength of current.

The goitre may be treated with a solution of iodide of potassium. The cathode in this case is a thin sheet of lead, which may easily be moulded to the gland and is covered with layers of sterile gauze which have been saturated with a solution of iodide of potassium; the anode is placed at the nape of the neck and the current should be turned on and off very gradually. Ten milliampères for 10 minutes should be employed. We should remember what has already been said, under the subject of cataphoresis, concerning the application of the iodide solution on the negative pole. Medical treatment should be used in conjunction with the electrical treatment.

**Hemiplegia.**—We should not use electricity for at least one month after the onset of this trouble. We may use central galvanization, provided we pass the current through the brain by different diameters so as to keep the lesion in a straight line between the electrodes. It is claimed that absorption of the effused products and improvement of the circulation takes place under this treatment. The faradic brush may be used over the anesthetic area and the sinusoidal current applied to the muscles. A general electrization by means of a sinusoidal bath is often very beneficial.

Various affections of the cord, among them anterior poliomyelitis and diseases of the peripheral nerves are almost always improved by proper electrical treatment. Anesthesia and both peripheral and cerebral circulation may be helped by using peripheral electrization. In treating hemiplegia mild faradization of relaxed muscles antagonistic to the contracted muscles should be employed. Usually, the flexors of the forearm are the muscles which are contracted; so we may use mild faradization of the extensors, as a prophylactic measure. Peripheral electrization sometimes gives remarkable results. High frequency may be used in hemiplegia.

**Hysteria.**—In this affection electricity has undoubtedly a psychic value. In hysterical anesthesia, aphonia, and paralysis, we should use sparks from a static machine; hysterical spasm may be treated by the sinusoidal current. The static head breeze is very useful in improving the general condition of the patient.

Faradism sometimes produces astonishing results in hysterical aphonia. High frequency treatment is sometimes indicated.

**Insomnia.**—We should search for the cause and, if possible, remove it.

Any form of general electrization may produce sleep. If the patient has high arterial tension, we use high frequency currents to reduce blood-pressure; if low arterial tension be present, we use static charging which raises blood-pressure.

The sinusoidal bath, the high frequency currents, central galvanization, and static charging may be used; we must bear in mind what has been said about high and low blood-pressure and so select the form of electricity indicated in a given case. Bachelet magnetic treatment may be given in cases with high blood-pressure.

**Locomotor Ataxia.**—There is no doubt that some of the good results obtained in the treatment of this disease by means of electricity depend on the psychic influence. In order to obtain results in employing electrical treatment, we must use electricity early. Direct galvanization of the cord and peripheral faradization of the skin may be employed. Sinusoidal applications are very effective in treating the lancinating pains and in the gastric crises. Static electricity is very useful in this disease.

It has been claimed that the optic atrophy of locomotor ataxia has been arrested by electric treatment. This the writer has never seen. In locomotor ataxia a course of four treatments a week for a period of seven weeks should be instituted; then a period of no treatments for seven weeks should follow. The alternation should continue until twenty-one weeks of treatment have been given, not including the intervals of seven weeks between the treatments.

Galvanization for ten minutes, followed by a rapid application of the faradic brush for five minutes are sometimes helpful where neuralgias and paresthesias are present.

Morton highly recommended the static current in this disease.

Very recently wonderful results have been obtained by the use of the high frequency currents in locomotor ataxia. The



lancinating pains are quickly relieved by them. We should also use the Fränkel treatment.

**Meralgia Paresthetica.**—The external cutaneous femoral nerve carries sensory fibres to the skin of the anterior and external surfaces of the thigh.

The following points in anatomy must be borne in mind: The posterior divisions of the second and third lumbar nerves divide into two branches; a smaller branch from each uniting to form the external cutaneous femoral nerve, and a larger branch from each which joins the whole of the posterior division of the fourth lumbar nerve to form the anterior crural nerve. The external cutaneous femoral nerve emerges at the outer border of the psoas muscle—about its middle—crosses the iliac obliquely to the notch immediately beneath the anterior-superior spine *under* Poupart's ligament into the thigh and separates into an anterior and a posterior branch. The anterior branch goes to the anterior and outer aspect of the thigh, and the posterior branch pierces the fascia lata and divides into branches to supply the *skin* on the posterior aspect, *one-half way to the knee*. The anterior branch supplies the *skin* on the anterior and outer aspect, *as far as the knee*. The external cutaneous femoral nerve and the middle cutaneous from the anterior crural, together with the crural branch of the genito-crural nerve supply the anterior and outer surfaces of the thigh. It is this distribution which should be the objective point of the treatment. In meralgia paresthetica there are numbness and, later, pain on the anterior and external surfaces of the thigh; the affection is usually unilateral, and occurs more frequently in men than in women. There is numbness only when the patient sits, but actual pain comes on when he walks. The pain often becomes so severe that the patient is obliged to stop and lift the affected leg from the ground to obtain relief. This affection may occur in tabes, in hematomyelia, and in malignant affections in the cavity of the pelvis. It is sometimes seen following difficult labor, and after an accident in which a severe blow was struck near the anterior-superior iliac spine. The writer recently treated a severe case of meralgia paresthetica in which there was such a marked scoliosis that the ribs of the affected side—the

right—pressed directly against the crest near the anterior-superior iliac spine.

*Treatment.*—Because of the varied etiology of this syndrome, much depends upon the detailed diagnosis; each case must be treated accordingly. Avoid cold douches; prohibit tight lacing; correct any deformity, such as flat-foot; treat any underlying cause, such as rheumatism; use hot salt baths, and inunctions.

The following electrical methods may be employed:—

Faradic electricity with a brush has been recommended. Personally the writer never uses the faradic brush in these cases. He employs the constant galvanic current, the large cathode placed over the lower spine and the smaller anode over the painful area, using from 8 to 20 milliampères for 8 minutes with a *séance* every day.

If this fails we may place the anode directly beneath the anterior-superior iliac spine of the affected side with the cathode and current strength as above. In the event of failure the writer has seen good results following the use of the sinusoidal current with the electrode placed as before. If the pain still persists and the patient seems to be suffering greatly, we use a 10 per cent. solution of cocaine on the anode, place the electrodes as above and use cataphoresis. It is important never to let the patient know that the anode has been moistened with cocaine solution. The cocaine should not be used oftener than thrice weekly, using the constant galvanic current on the intervening four days. Of course, the galvanic current is the modality employed in giving cataphoresis.

High frequency currents help very much in relieving the pain in this affection. We should give general treatment for ten minutes by means of the "auto-pad" and follow this with a ten minutes' treatment over the affected area, using a surface electrode. Treatment should be given daily. Cataphoresis by means of the high frequency cataphoric vacuum electrode may also be used.

**Melancholia** and mental apathy are usually accompanied by failure of general nutrition; so we use sinusoidal and high

frequency currents. The improvement in general nutrition is usually followed by marked relief of the mental symptoms.

**Neuralgia and Neuritis.**—It has been said by the opponents of electro-therapeutics that the treatment of these conditions is purely psychic, but those who have seen the really remarkable results obtained from electrical treatment in these painful conditions will understand how unjust are such statements. The one real trouble encountered in the use of electricity in neuralgia is that physicians often use the same form of electricity in every neuralgia, without any discrimination whatever.

In the case of a referred pain—as when hip-joint disease produces a secondary sciatica—we use the faradic brush, with the current from a secondary coil having about 3000 feet of wire. The skin must be dry because we wish to produce counter-irritation, but if we have a local neuritis harm may be done if we use the faradic current. In the case of a local neuritis we should employ the constant galvanic current placing the anode on the painful area and the cathode on an indifferent point, like the sternum. We should always turn the current on and off very slowly, and be very careful not to use a strong current. A current from 2 to 10 milliampères is usually the proper strength. The following methods may be employed:—

(1) Stable galvanic anode; (2) stable franklinization; (3) faradic brush; (4) cataphoresis, by means of the galvanic current. The stable galvanic anode should be small and round and be covered with well-moistened cotton. The cathode placed on an indifferent point should be larger. This method is known as sedative treatment.

Stable franklinization is attained by placing a metal ball electrode, from a static machine, over the painful parts. The discharging rods which have been in contact are now gradually separated until the pain becomes almost unbearable; we continue this for two or three minutes.

The faradic brush, with a strong secondary current, may be used for about one minute. Cataphoresis, by means of the galvanic current, gives wonderful results in the treatment of neuralgias.

Sinusoidal currents sometimes aid very much in the treatment. The electric treatment of intercostal neuralgia, abdominal neuralgia, and mastodynia very often fails unless high frequency currents are used.

Rheumatic neuralgias and traumatic neuralgias are the varieties most successfully treated by electricity.

Trigeminal neuralgia usually gives good results, but sometimes we meet with obstinate cases which resist all treatments. In these cases we should try cataphoresis with cocaine, using a solution of cocaine, as mentioned in the article on cataphoresis. This usually gives temporary relief; it should be followed by a 1-per-cent. solution of muriate of quinine, which yields persistent result. The effects of this quinine treatment are sometimes marvelous. A large cathode should be placed upon the upper cervical vertebrae and the small anode upon the painful points of the nerve; 3 milliampères for 3 minutes should be given. We should not move the electrode about and we should always avoid fluctuations of the current; we should never use faradization or static electricity, as these increase the neuralgia.

Occipital neuralgia should be treated by placing a small anode upon the upper part of the neck on the affected side, and a large cathode upon the sternum; 3 to 5 milliampères should be applied steadily for 5 minutes.

Occipital neuralgia may be due either to hysteria or to an incurable disease; so we should not be surprised if at times we fail to get good results in this condition.

In treating neuralgias of the brachial plexus, we should first apply the cathode upon the cervical spine and the smaller anode in the supraclavicular fossa; 2 to 5 milliampères should be given steadily for 3 minutes. The cathode should next be placed in the fossa, and the anode over the nerve to be treated—the radial, musculo-spiral, median, or ulnar—using from 5 to 10 milliampères steadily for from 3 to 5 minutes.

**Occupation Spasm.**—Writer's cramp, probably the best example, should be treated by the high frequency or by the sinusoidal currents, both of which give striking results. The constant current mono-polar bath is the form of electricity usually recommended, but far more gratifying results may be

obtained from the use of the sinusoidal currents in the following manner: One electrode is put in a basin of water, into which the patient's hand is placed, while the other electrode is applied on the shoulder of the affected side. The treatment should be given at first daily and gradually decreased until but two applications a week are given. Of course, we advise a change of occupation, so as to give the affected arm absolute rest from the occupation which produced the spasm. High frequency applications to the affected hand and arm, give very gratifying results. The Fränkel method should be used in addition.

**Paralysis.**—Much of course depends upon the cause of the paralysis and the diagnosis is most important. We should understand among other things testing for R. D., tracing the seat of the lesion, whether in the upper or lower motor segments, or whether it is of functional origin, as in hysteria. Further, we should not give, as recommended by some authors, electricity for all forms of paralysis. Thus it should never be employed in spastic paralysis, unless it be given to strengthen the opponent muscles.

The form of electricity to be applied will vary greatly. Faradic electricity may frequently be employed; almost every physician has some form of faradic battery. If we use galvanism we should place the anode at the back of the neck or other indifferent point and use the cathode labile over the affected muscles. The combined current may be used in the same manner. If we are fortunate enough to possess a sinusoidal apparatus—especially one with a rheotome—we may use the sinusoidal bath.

The following forms of paralysis are briefly considered:—

**Deltoid Paralysis.**—Trauma of the shoulder or dislocation at the shoulder joint may give rise to paralysis of the deltoid muscle; the latter is supplied by the circumflex nerve. We have here a very obstinate form of paralysis to deal with. We usually find flattening of the shoulder and note that the elbow hangs nearer the thorax on the affected side. The patient is unable to raise the arm to a horizontal position at the shoulder. We should, of course, be very guarded in our prognosis. One electrode—the anode—should be placed at the back of the neck

while the other should be stroked over the affected muscle. We may use a combined current—the secondary faradic and the constant galvanic. The high frequency currents and, later, the sinusoidal current may be used.

**Erb's Paralysis.**—The trouble about to be described should not be confounded with Erb's Syphilitic Spinal Paralysis. A condition known as Erb's paralysis frequently occurs in infants from injury to the fifth and sixth cervical nerves from traction exerted on the neck and head during delivery. In adults, cold, a fall, or a blow on the neck may produce the same condition. The muscles paralyzed are the biceps, deltoid, brachialis anticus and supinator longus with, occasionally, the extensors of the hands.

Stimulation of Erb's point—at a spot one inch above the clavicle, just in front of the transverse process of the sixth cervical vertebra and a little to the outer side of the posterior border of the sterno-mastoid—in a healthy person, will produce contraction simultaneously in the muscles enumerated. The circumflex nerve supplies the deltoid; the musculo-cutaneous supplies the biceps and the brachialis anticus; the musculo-spiral supplies the supinator longus.

It is very easy to recognize Erb's paralysis from the way the arm is held. The arm hangs straight down at the side and the hand rotates inward, so that the palm looks backward.

Treatment should be started within six weeks if possible. The constant galvanic current should be employed. A large electrode should be placed over the lower cervical vertebra, and the cathode in the axilla; we should apply 3 milliampères for 4 minutes. By using the cathode labile we cause each individual muscle to contract feebly, using the weakest current possible. The whole application should last not more than 12 minutes and should be given thrice weekly.

**Facial Paralysis.**—This, as is well known, may be either central or peripheral in origin. The face may be paralyzed by (1) lesions of the cortex—supranuclear palsy; (2) lesions of the nucleus itself; (3) involvement of the nerve trunk in its tortuous course through the temporal bone.

(1) Supranuclear paralysis may be caused by tumors,

abscesses, chronic inflammation, or by other lesions in the cortex, in the region of the internal capsule or other portions of the upper motor pathway. Usually supranuclear paralysis is part of a hemiplegia, the paralysis being on the same side as that of the arm and leg, because the facial muscles have exactly the same relation to the cortex as do the spinal muscles.

(2) Nuclear paralysis is seen in tumors, chronic softening, and hemorrhage; and it has been seen complicating anterior poliomyelitis.

(3) Involvement of the nerve trunk may follow:—

(a) Lesions of the nerve as it passes through the pons—the alternating or crossed paralysis of hemiplegia—the face being involved on the same side as the lesion, and the arm and leg on the opposite side. The lesion in this case is above the point of decussation in the medulla.

(b) A fracture of the base, gummata, meningitis or tumors may cause involvement of the nerve at its point of emergence from the pons.

(c) In disease of the ear, especially in otitis media in children, the nerve may be involved in its passage through the Fallopian canal.

(d) Injuries and blows which frequently cause paralysis of the face, at the point where the facial nerve emerges from the styloid foramen. This paralysis may also be caused by pressure of the forceps in an instrumental delivery. Sometimes the fibres are cut in removing tumors at this point.

(e) A neuritis of the nerve within the Fallopian canal or at the stylo-mastoid foramen due to exposure to cold, is the most common cause of paralysis of the seventh nerve. Syphilis at times also causes this paralysis. Facial diplegia is occasionally seen in lesions in the pons, in diphtheritic paralysis, and in some affections at the base of the brain.

In peripheral paralysis of the seventh nerve, all of the branches are involved. As soon as the patient is told to show his teeth, the paralysis becomes exaggerated. Herpes may also be present in facial paralysis, the eruption being found over the external ear. The sense of taste is not affected when the nerve is injured *outside* the skull. The face on the affected side may

be swollen; deafness may be present; pain is usually absent, but there may be neuralgia of the ear.

In central facial palsy, we find no change in the electrical reactions. In peripheral cases, electrical changes ensue but may not appear for a few days. Mild cases of facial palsy may never show R. D., while the severe forms may show complete loss of electrical reaction. We may expect any degree of severity between these two extremes.

The electrical reactions are very important from a prognostic standpoint. If we find no change either to the faradic or to the galvanic current, we may expect recovery in about three weeks. If but slight R. D. be present, we may look for recovery to take place in from six to ten weeks; if there be marked R. D. we may still expect recovery, although it may require from six to fifteen months to effect a cure.

Of course our prognosis will depend on whether R. D. is present, or not, and on the cause of the palsy. The prognosis will not be so favorable if middle ear disease be the exciting cause as it will be if the palsy be due to rheumatism, gout, or cold.

*Treatment.*—If R. D. be absent, we may use the secondary faradic; if R. D. be present, we may use the constant galvanic current.

It is a good plan during the treatment to test occasionally for R. D. to aid in giving a prognosis. In traumatic cases, surgical interference should be considered.

If pain be present, we place the negative galvanic pole either in one hand or under the ear of the affected side and use the positive pole in a labile manner over the painful area.

If there be no pain, the positive galvanic is placed near, or over, the mastoid of the affected side while the negative pole is carried over all of the affected muscles. We use a current strength of 3 milliampères for five minutes. We do not make or break the current or we will cause the patient to see flashes of light.

After we have given the galvanic treatment, we should at the same sitting use the high frequency vacuum surface electrode and give this form of electricity for five minutes.



If there be any trouble with the eye of the affected side—such as drooping of the lower lid, or conjunctivitis—we should use the single-eye electrode for five minutes, employing the high frequency current.

This outline of treatment differs from the usual method advocated by electro-therapeutists. If we follow the method here described, we will cure our patients much more quickly.

If we have only a faradic battery, we may use the secondary faradic current in the same manner as the galvanic current. We should, however, remember that the faradic battery will be of no avail if R. D. be present.

**Musculo-spiral Paralysis.**—We here find a characteristic wrist-drop, with involvement of the triceps if the injury be high up. Pressure from a crutch, or from the weight of the head on the arm during sleep, is usually the cause of this form of paralysis. A history of alcoholism is often present.

Double wrist-drop may indicate lead poisoning. We should give a guarded prognosis, allowing ourselves at least four months if R. D. be present, and one month if R. D. be absent.

The combined current is indicated with the indifferent (the *anode*) electrode on the sternum or at the back of the neck, and the active electrode labile over the affected muscles. High frequency currents are very useful here.

**Serratus Magnus.**—Paralysis of this muscle is found after injury of the posterior thoracic nerve which comes from the fifth, sixth and seventh cervical cords. If we instruct the patient to hold his arms straight out before him we at once notice the “winged appearance” of the scapulæ. We should place the indifferent electrode—in this case it would be the *anode*—in the posterior triangle of the neck and use the active electrode labile over the affected muscles.

**Sterno-mastoid and Trapezius.**—Injury to the spinal accessory nerve will produce paralysis of these muscles. We find drooping of the shoulder on the affected side in paralysis of the trapezius. In a case of paralysis of the sterno-mastoid the muscle does not stand out prominently when the head is turned to the opposite side.

The treatment consists of the use of the constant current,

the anode being applied to the back of the neck and the cathode labile over the affected muscle. We may also use high frequency currents by means of a surface electrode.

**Ulnar Nerve.**—R. D. may be present. If found and the case be advanced, we will find the characteristic “claw hand” or “main en griffe;” and sensation will be lost in the little finger and in the ulnar half of the ring finger, together with the corresponding part of the palm.

*Treatment.*—We should use the combined current, the anode on the sternum and the cathode labile over the affected muscles. Good results will follow the use of high frequency currents.

**Peripheral Nerves.**—The value of electrical treatment in hastening recovery after injury or disease of the peripheral nerves is now known even to the laity. Of course, the nerve trunks superficially seated are the ones most commonly injured and hence treated. We may meet with any injury, from a slight one, which produces only numbness, to one which may cause complete loss of both motion and sensation. The shoulder and arm are both prone to injuries, though the lower extremity is by no means exempt. If the palsy result from a trauma, such as a blow or an incised wound, the wisdom of surgical intervention should first be considered. Having satisfied our minds that such intervention is not indicated, we should at once proceed to treatment by electricity.

The current to be used will depend entirely on the history of the case. If there be much pain, we should employ the constant galvanic current with the anode over the painful area. The high frequency currents act in a marvelous manner in helping to relieve the terrible pain met with in neuritis. Later we may use the sinusoidal current. As the pain diminishes and the paralysis improves, we may apply the secondary faradic current or, better still, the combined current—the secondary faradic and the constant galvanic at the same time. If the patient presents himself without pain, we may at once try the sinusoidal current, the secondary faradic, or the combined currents, any one of which may be employed with either slow or fast interruptions by using the automatic rheotome. Other

things equal, we should begin with that form of current which gives muscular contraction with the least pain—the sinusoidal current.

Neurites from septic or specific diseases, metallic poisons, injuries, gout, rheumatism, or alcohol are always benefited by electrical treatment, if the proper modality be used.

Peripheral paralyses are of different varieties so that even in different distributions of the same nerve we meet with different symptoms. These peripheral paralyses need not be considered in detail. Some of the principal nerves, however, require special mention.

**Median Nerve Paralysis.**—A similar plan of treatment is to be pursued as in treating ulnar palsy, a description of which was given on page 167.

**Musculo-spiral Paralysis.**—See Page 166.

**Prostate, Enlarged.**—The enlarged prostate has caused more anxiety, actual suffering and discomfort than any other condition in senile life. This is a distinctly surgical condition. However, the fact that it occurs in patients in whom senile and degenerative changes have become pronounced in blood-vessels, heart and kidneys, often causes the surgeon to hesitate before attempting a radical operation. Such cases are very properly treated by electrical methods. Bottini's operation, described elsewhere in this book (see page 107), offers some hope. Many patients object to any operation on the prostate and prefer to endure their existing discomforts, trusting for relief to the use of the catheter. It is in this class of patients that we should employ the high frequency currents. It has been recommended to use the Röntgen rays in treating the hypertrophied prostate, but the writer does not believe this to be good practice, as it is almost impossible to concentrate the rays on the prostate. The Morton wave-current or the high frequency currents are to be preferred. In applying the Morton wave-current we use a metallic electrode attached to the positive pole of the static machine, while the negative is grounded. About 250 interruptions per minute should be used. If the interruptions are too frequent, we cause the prostate to be held in a state of tonic contraction without permitting any interval of relaxation. Another

method is to ground the positive—not the negative as previously indicated—and then to use a vacuum glass electrode attached to the negative side of the machine.

Dr. Titus, of New York, deserves the credit for devising the very useful insulated vacuum electrode which is especially suited for treating the enlarged prostate. He recommends the following:—

“After the rectum has been emptied, the patient is placed in the Sims position, upon an insulated platform. This platform should be insulated by glass legs, not less than twelve inches in length, and be at least three feet distant from the machine. The vacuum tube, after being lubricated, is passed into the rectum and pressed against the prostate gland or seminal vesicles. The instrument is held in position by an ordinary tube-holder and stand. The ordinary connecting wire or rheophore is fastened to the electrode and to the negative side of the static machine. The strength of the current is determined by the length of the spark-gap between the balls of the sliding rods of the machine.”

He begins with a small spark-gap and gradually increases according to the effect produced and the tolerance of the patient. The treatment should never be painful.

*Treatment of Enlarged Prostate by High Frequency Currents.*—The patient is placed on a couch in the Sims position. The couch need not be insulated. Lubricate a Snow vacuum rectum electrode and pass it into the rectum, holding it firmly against the prostate gland. Treatment for ten minutes should be given every second day. We will find that under this treatment the number of night urinations will decrease so that the patient may not be required to get up more than once during the night. The general opinion now is that the Morton wave-current—using a metal electrode—is the more effective in the congestive type of prostate enlargement; the high frequency currents seem to do more good in that form which follow gonorrhoeal infection. We should remember to ground the positive and attach our electrode to the negative when we apply a *vacuum* rectum electrode to the prostate. We ground the negative and attach the electrode to the positive pole when we apply a *metal*

electrode to the enlarged prostate. It is not necessary to move the electrode about, as has often been advised. The great advantages of the electrical treatment of prostatic enlargement are that no ether is required and consequently there ensue no vomiting, no shock, no long convalescence with consequent loss of time from business, and no danger of infection.

**Sciatica.**—A great deal has been written of the electrical treatment of sciatica. The faradic current has been recommended by some and condemned by others. The first thing to learn, if it be possible, is the cause of the sciatica. As a rule we do not use any form of electricity until the sciatica has existed for at least four weeks. In the early stage, dependence must be placed on rest, medicines, and local applications.

The pain of sciatica may be greatest in that part of the nerve near the middle of the thigh or at the sciatica notch.

Sciatica may be due to anal fissure, hemorrhoids, or disease of the prostate, pressure of the fetal head, tumors of the uterus, and occasionally to hip-joint disease. The pain is then a referred pain, and the faradic brush or the high frequency current is indicated.

In using galvanism we place a large cathode against the iliac fossa and a smaller anode along the course of the nerve. It is necessary to use from 20 to 40 milliamperes on account of the depth of the nerve. The patient must be lying down, not standing, and the muscles should be relaxed, in order that the electricity may reach the nerve.

It is in the neuralgic sciaticas that we usually get our best results. In chronic cases, we may use the combined current, the sinusoidal, or even static applications. Usually only the mild cases of sciatica receive benefit from static applications. High frequency currents may be tried.

**Spasms and Tremors.**—Treatment here will depend upon the cause. We should first try sinusoidal currents; if we meet with failure, we should try the constant galvanic or high frequency currents.

**Varicose Ulcers.**—Much has been written about the treatment of varicose ulcers. Dusting powder, ointments, lotions, elevation of the leg, bandaging and elastic stockings have all

been used. The indication is to diminish the induration of the tissues so that the ulcer may heal. Of course many cases should be sent at once to the surgeon, for extirpation of the veins.

In the electrical treatment of this condition we should use either the Morton wave-current or the high frequency currents. In giving the Morton wave-current we place a piece of block-tin—a “block-tin” electrode is a roll of plastic sheet metal which resembles sheet lead—about 7 inches square, over the ulcer and hold it in position by means of an ordinary surgical bandage. We then ground the negative pole and connect the block tin with the positive. We should now, very slowly, separate the sliding rods. We will discover that the patient will not tolerate a separation of the prime conductors for a distance greater than  $\frac{3}{4}$  of an inch. Yet it will be found that, at every successive treatment we will be able to increase the distance until we are able to make the separation of the prime conductors as great as  $3\frac{1}{2}$  to 4 inches. In giving this treatment the patient should be placed upon the insulated platform, with the leg elevated.

The static-brush discharge is very useful, especially if preceded by a prolonged application of light, as recommended by Dr. Snow, of New York. Dr. Snow uses a bandage of crepe velpeau, which he thinks is more comfortable than the rubber bandage. He reports marvelous results in cases of phlebitis. It is well to remember that a prolonged light treatment will soften down the indurated edge, which may then be removed by means of the wave-current. We should always order artificial support, such as an elastic stocking.

**Vomiting of Pregnancy.**—Treatment by drugs should be used, and the bowels kept regulated. In many cases electricity is of advantage. We apply the induction coil of fine wire, placing the negative pole at the back and the other pole over the epigastrium so that the current is made to pass directly through the stomach. It seems hardly necessary to state that the current should be kept away from the neighborhood of the uterus.



Fig. 84.—Victor No. 1 massage outfit.

## CHAPTER XV.

### VIBRATORY MASSAGE.

---

RECENTLY the medical profession has had its attention forcibly drawn to electric massage against which there has been much prejudice; this was due chiefly to the poor machines used. It is well known that a machine-driven instrument can produce several effects not produced by the hand. The hand soon becomes tired, so that the latter part of a treatment by the hand is never the same as when the operator is fresh.

In a good vibratory massage machine there should be no jarring or knocking, the machine should be almost noiseless, and the vibrations should be uniform. A good vibrator should have high speed without noise and should impart no vibration to the hand of the operator. The patient, not the operator, needs the vibratory massage. The machine should be strong, yet simple of construction; it should be light, yet powerful; it should have a universal handle, with flexible shaft which will assume natural curves; it should connect with any electric lamp socket, and be so arranged that there is no possibility of receiving an electric shock; it should afford great range in variations of speed. A good vibrator should be able to produce thousands of oscillating movements per minute.

The therapeutic value of vibratory massage is shown by its successful use in the following conditions:—

Abdominal and pelvic inflammations.	Deafness.
Catarrh, whether in ear, nose or stomach.	Insomnia.
Constipation.	Locomotor Ataxia.
Contractures.	Lumbago.
	Muscular atrophy.
	Nervous headache.
	Neuralgia.



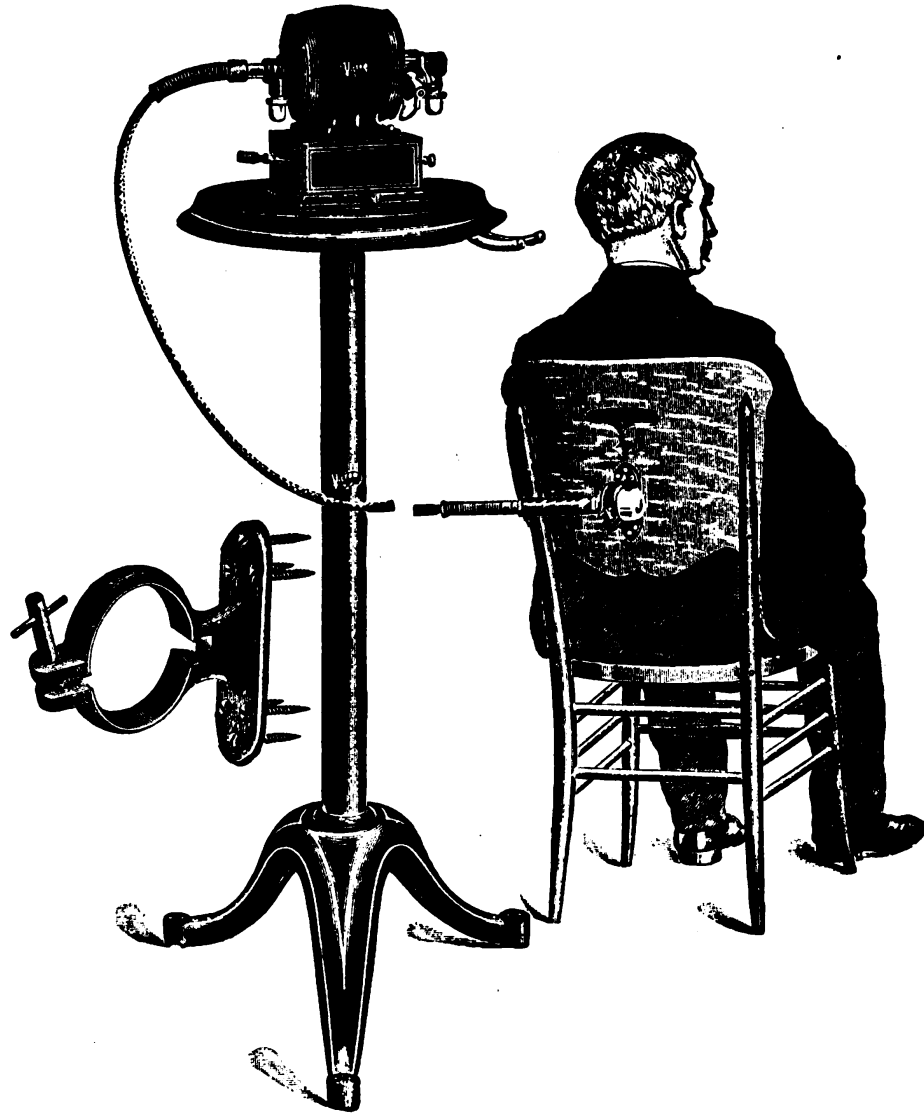

Fig. 85.—Victor chair and vibrator.

Rheumatism.  
 Sluggish circulation.  
 Stomach and intestines  
 —in atonic condi-  
 tions.

For weak and unde-  
 veloped children.  
 As a weight reducer in  
 obesity.

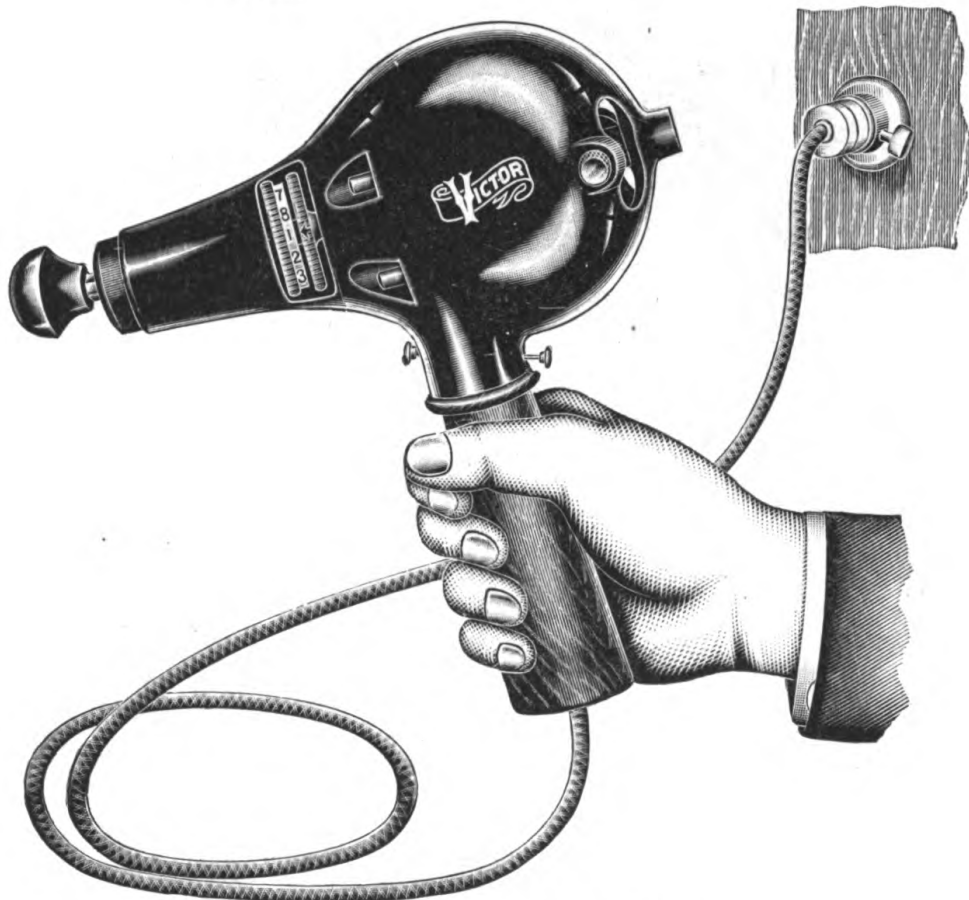

Fig. 86.—Victor portable vibrator.

Vibratory massage should not be employed in:—

Aneurysms.  
 Arteriosclerosis.  
 Acute inflammations.  
 Erysipelas.  
 Malignant tumors.

Pathologic changes in  
 the walls of the  
 blood-vessels.  
 Purulent local condi-  
 tions.  
 Tuberculosis.

It is impossible, save approximately, to state how many minutes a treatment should be continued. Usually five minutes is the proper length of time required in treating any group of muscles. A treatment over the whole body should be carried

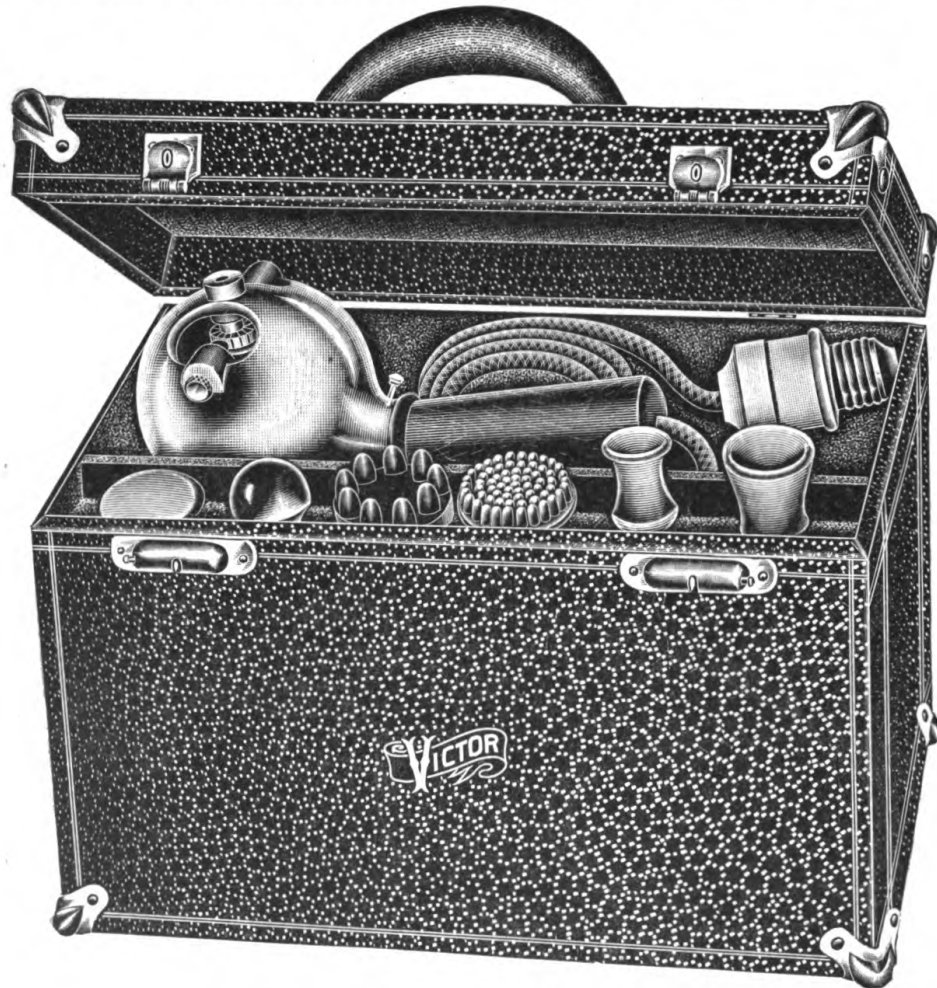

Fig. 87.—Victor vibrator in carrying case.

out in fifteen minutes. Large muscles require more time for proper treatment than do small muscles. As a rule, the treatment proves to be beneficial and has not been too prolonged if the patient feels invigorated. The operator should at once stop treatment on the first signs of fatigue shown by the patient. As in applying electricity itself we must study each individual case.

## CHAPTER XVI.

### LIGHT AND HEAT THERAPY.

---

THE fact is very well established that light as a therapeutic measure is of great importance. We now use light in some cases where electricity does not produce good results. We know that the different rays of the spectrum produce varying effects on the animal organism. Professor Finsen thought that the curative value of light was greatest at the ultra-violet end of the spectrum. The Finsen apparatus is arranged to gather a great number of ultra-violet rays and to eliminate the remaining rays of the spectrum. While we find the ultra-violet rays very useful in the treatment of disease, we must remember that the penetrating power of these rays is very limited. A thin layer of blood will absorb very many of the ultra-violet rays and leave but a small percentage of rays to penetrate the deeper tissues. The blue rays possess a greater power of penetration and the red and the infra-red a still greater power.

Physiologic processes are rapid under red light, somewhat slower under green, and much slower under the violet. Experiments on animals have shown that the animal seems to be comfortable under the red or orange light, not so much so under the green and has a desire for sleep under the violet. Parville claims that the red end of the spectrum is nerve irritating, while the violet end is nerve soothing.

Professor Schlager tried to quiet maniacs by placing them in a room which had blue glass windows. In some cases he succeeded after medicinal treatment had failed. (?)

The red rays carry the heat, which is so useful in treating deep-seated parts. Years ago it was known that small-pox would not pit if the patient were placed in a room, the windows of which were of red glass. It is now known that the good result

(181)

obtained is due to the exclusion of the other rays of the spectrum, which act as irritants in these cases. By eliminating all but the red rays we prevent pus formation and thus escape the secondary fever and the unsightly scars. As is well known, the spectrum, which is simply a zone of blended tints, is composed of violet, indigo, blue, green, yellow, orange and red. At each end of the spectrum we find more rays; beyond the red we have the infra-red rays; beyond the violet we have the ultra-violet rays.

Different colors have different wave lengths, accepting the theory of Huyghens. These lengths diminish from red to violet. Each color has its own rate of vibration. Red has the lowest and is least refracted; violet has the highest vibration, and is the most refracted or retarded.

In the spectrum the highest temperature is shown beyond the visible red rays. The actinic or chemical rays are found beyond the violet end. The actinic rays are employed in affecting changes in the skin and in the decomposition of the silver salts in photography.

We all know how plants turn toward light. This property is known as "Heliotropism." In 1877, Downes and Blunt demonstrated that bacteria are killed both by direct and diffused lights. Dieudonné in a series of experiments proved that bacteria are killed by direct sunlight, by diffused daylight, and by the light of the incandescent lamp. All bacteriologists now know that cultures allowed to remain in the direct sunlight are very soon destroyed. It is customary for bacteriologists to keep cultures in a dark compartment.

We should remember that the chemical intensity of light is not synonymous with the greatest optical brightness. The chemical action of the incandescent electric light is slight. This is because it has very few violet and blue rays, but many yellow, orange and red rays. By increasing the current strength, we are enabled to increase the violet and blue rays together with the optical brightness.

As the incandescent electric light contains almost no actinic or chemical rays, the only therapeutic effect that it has arises from the heat generated.

Practically the only sources of the actinic ray are the sun's rays and the energetic rays of the electric arc. The rays of the sun are of a threefold character—heat or thermic, light or luminous, and chemical or actinic.

The electric arc itself gives off violet or actinic rays. The carbon points, when heated to incandescence, give off thermic and luminous rays, so that the rays from an arc light are mixed. The electric arc contains more actinic rays than does sunlight having the same luminous power. The longer the arc, the larger the proportion of actinic rays. We lengthen the arc when we separate the ends of the carbons. The electro-therapeutist should know the difference between convective heat and radiant heat. When we apply convective heat, the blood is heated and passes onward to be replaced by blood of normal temperature. In this manner only the superficial structures are affected. When we apply radiant heat the effect is very different. The radiant energy becomes heat energy, only after it has been converted by coming in contact with the tissues. Radiant light passing through glass will not be converted into heat units until it has been absorbed by a body. We know from this that the depth of penetration into the tissues will depend entirely upon the volume and penetration of the radiations used.

**Actino-Therapy.**—This treatment was introduced by Finsen. By means of rock-crystal lenses, he concentrated the actinic light and at the same time, by means of pressure, removed from the injured part as much blood as possible. Finsen knew that blood prevents the passage of the actinic rays to the tissues.

At the present time there are on the market different makes of lamps which are patterned after the original Finsen lamp. The apparatus consists of the light, the cooling apparatus, and the light-concentrating apparatus.

It has been learned that the composition of the electrodes has much to do with the quantity of ultra-violet rays. There is now on the market a lamp in which iron electrodes, cooled by water, are used. These lamps give a large quantity of actinic rays with but a small amount of heat. They should be used only

in the treatment of superficial troubles, as the actinic rays are not penetrative in character.

The electric arc is the best means for producing the so-called Finsen rays. The combination of iron in the electric arc produces these rays in the greatest volume. Finsen concluded

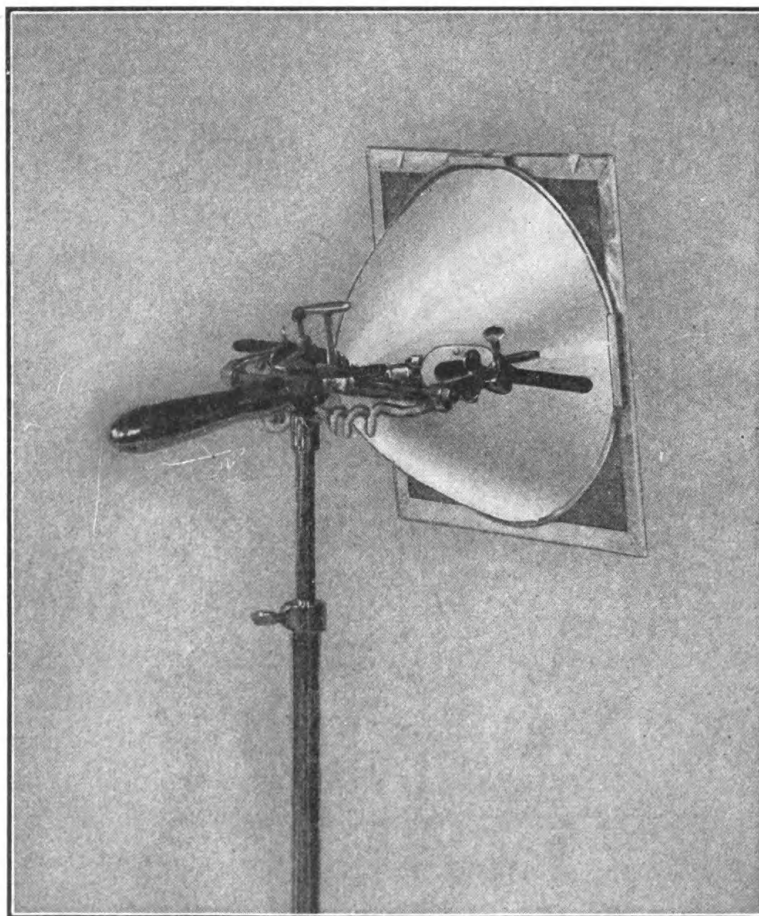

Fig. 88.—Modern Medicine Co.'s lamp.

that the germicidal power of light lies in the ultra-violet rays almost entirely. Later investigators have verified his conclusions.

The lamp described in this book is known as the Solar Therapeutic Arc Lamp, made by the Modern Medicine Co., of Battle Creek, Michigan.

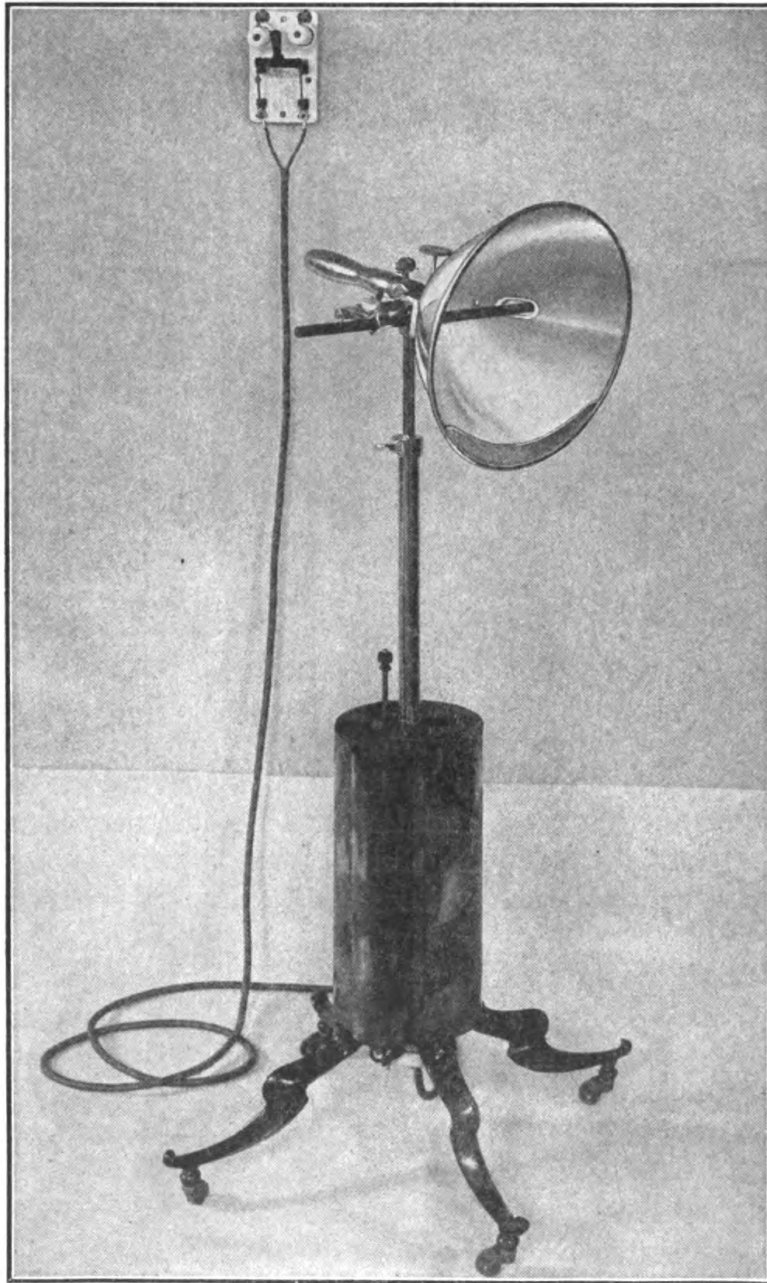

Fig. 89.—Modern Medicine Co.'s lamp (second view).



It has the following special advantages:—

1. *Efficiency.*—The deep parabolic reflector enables one to utilize four-fifths of the energy emitted by the electric arc. This is very important, as it is a matter both of economy and of convenience.

2. *Convenience.*—The method of mounting and holding the carbons is admirable, as the carbons may be adjusted either vertically or horizontally. The lamp may be adjusted to any height or angle.

3. *Power.*—The rheostat enables one to vary the power. We are enabled to obtain the effects of a powerful burning glass or to tone the power down to the warmth of moderate sunlight. The full rays of the arc light consist of a combination of heat, light, and chemical rays. We may cut out the actinic or chemical rays by using a red glass screen. When we especially wish to use the actinic rays and wish to eliminate the thermic rays, we use a violet glass screen.

4. *Actinic Rays.*—The rays are obtained with this lamp by such an adjustment of the carbons to the parabolic mirror as will bring about a separation of the chemical or violet rays obtained from the *central portion* of the arc from the thermic or luminous rays produced by the incandescent carbon points. By this arrangement the chemical rays are concentrated in one part of the field, while the thermic rays are sent to another, thus making it possible to utilize the chemical rays without the thermic.

**Violet Ray Therapeutic Lamp.**—This lamp, which has iron electrodes, gives a great volume of chemical rays and so produces powerful actinic effects. The iron electrodes are made of the same size and length as the ordinary carbons and they may be used in the lamp described above. The iron electrodes are hollow, tipped with steel points which are screwed in place. The electric arc is formed between these points, which are cooled by the circulation of water through the metal tube. The apparatus will stand a water pressure of 200 pounds to the square inch.

As a counter-irritant, the chemical ray has no equal. Fomentations, clay poultices, and the simple water poultice produce a hyperemia of the skin which gives but a temporary

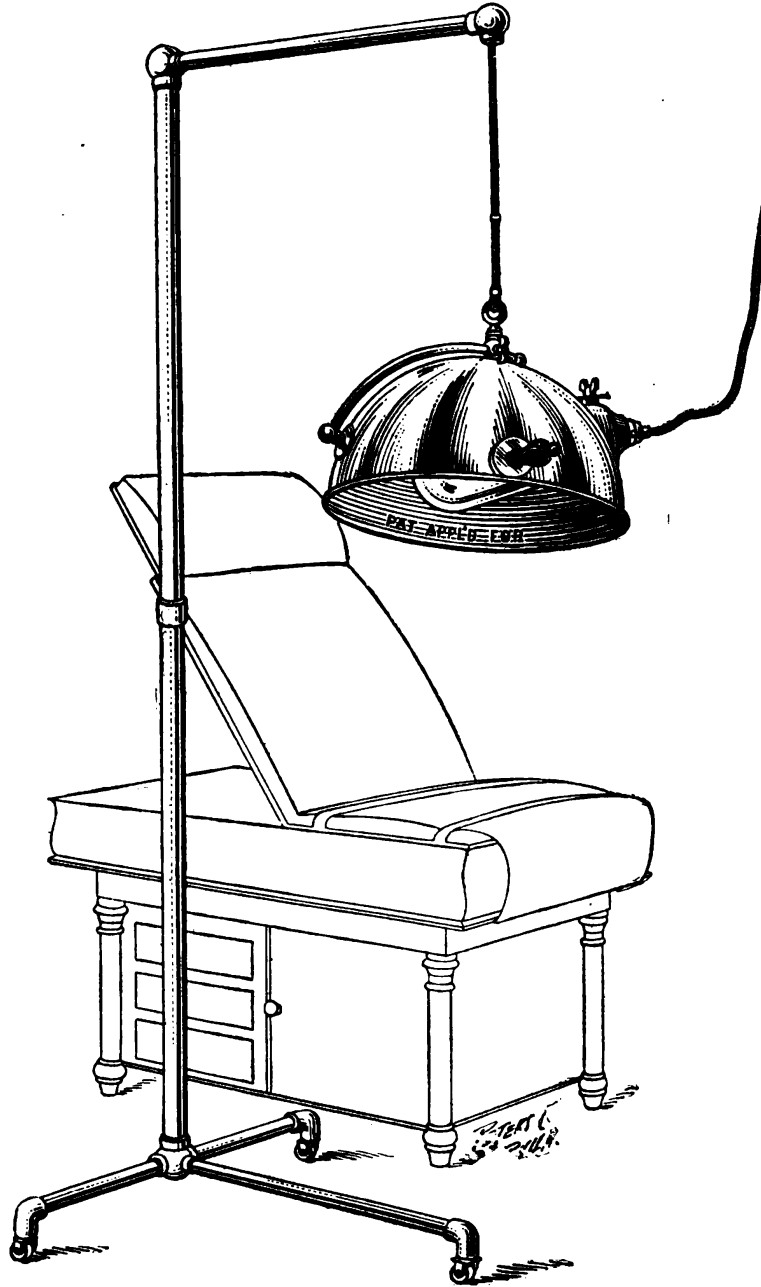

Fig. 90.—Incandescent lamp.

relief in visceral pain. The same is true of cupping or leeching. The chemical ray will produce an erythema which will produce all the good, but none of the bad effects of a mustard plaster or of a blister. This erythema appears a few hours after the application. If the burning is too severe, we should dust the part with powdered zinc oxide. The advantage of the erythema is that it usually lasts for some days and thus produces a more persistent effect. The method is very extensively used as a means of relieving visceral congestion and pain in cases of chronic gastric and hepatic disorders, in renal disease, in bronchial, gastric and intestinal catarrhs, and in various forms of muscular and neuralgic pains.

**The Incandescent Therapeutic Lamp.**—The source of light is a high candle-power, incandescent bulb which produces an exceedingly intense light, capable of producing powerful thermic effects. It should be clearly understood that this lamp does not produce actinic rays to any extent, so that we do not find the sunburn or solar erythema seen when the solar arc lamp is employed.

We should remember that at times we need the thermic rays instead of the chemical or actinic rays, and at such times we use the incandescent lamp rather than the solar arc lamp. Each lamp has its field of usefulness, and each lamp should be in the office of every electro-therapist. In cases of sciatica, lumbago, neuritis, and various forms of neuralgia, the powerful rays of the incandescent lamp often produce wonderful effects. In cases of chronic joint disease, this lamp is far superior to heat apparatus of different kinds and also to Bier's method. The object in using a bulb of high candle-power is to increase the distance the lamp is to be held from the patient.

The incandescent electric light is useful in treating anemia, arteriosclerosis, valvular heart disease, lumbago, neurasthenia, migraine, and in some cases of tuberculosis.

The incandescent therapeutic lamp here described is made by the Philadelphia Sanitarium Co., Philadelphia. The special advantages of this lamp are: 1. Its lightness and portability; 2. It is easily adjusted; 3. It can be focussed to give parallel rays, so that deep penetration may be produced from a distance

above the surface of the human body; 4. Owing to the construction of the reflector the outside of the reflector never becomes hot, although more heat than the patient will endure may be produced from the inside of the reflector. The explanation of this is found in the fact that inside the reflector the rays are reflected instead of being absorbed.

### SPECTRUM OF SUNLIGHT.

Infra-red	Red	Orange	Yellow	Green	Blue	Indigo	Violet	Ultra-violet
-----------	-----	--------	--------	-------	------	--------	--------	--------------

Fig. 91.—Diagram of Spectrum.

**Summary.**—From numerous investigations it is now believed that the violet and ultra-violet are bactericidal and antiseptic; the blue rays and the central portion of the spectrum are tonic, sedative, and penetrative; the red and infra-red are stimulative, slightly irritant, deeply penetrative, and thermal.

**Treatment of Smallpox by means of Red Light.**—Although the fact that pitting in smallpox might be prevented by keeping the patient in a room into which only red light is admitted, was known for hundreds of years, it remained for Finsen to explain this fact scientifically. Finsen proved that no actinic rays are contained in red light. He arrived at his conclusion after learning that, during an epidemic of smallpox, the patients who had been confined in a dungeon, and so were excluded from the daylight, recovered *more quickly* and had less scarring than did those who were exposed to daylight.

Finsen proved that the blue, indigo, violet and ultra-violet rays of the spectrum are the actinic or chemical rays. Finsen's experiment with earthworms is very interesting. Into a box, covered half with blue glass and half with red glass, he placed earthworms and watched the result. Under the red glass the worms lay quiet; under the blue glass they were very restless and exceedingly active. Under the red glass would be found heat or thermic rays; under the blue glass would be found actinic or chemical rays, which probably caused the restlessness and increased activity of the earthworms.

**Blue Light.**—There are many physicians to-day using the concentrated actinic rays in the treatment of lupus and chronic

ulcers. Recently, by the use of screens of blue glass, we have been enabled to employ the chemical frequencies of the spectrum. By the use of such screen we are enabled to shut out the ultra-violet portion of the spectrum on the one side and the green and red frequencies on the other side of the spectrum.

In the London Hospital, blue light as an anesthetic has been used with varying results. In the successful cases there were dilatation of the pupils, fixation of the eyes, and drooping of the eyelids; the patient seemed to be in a somnolent condition. No pain was felt during the operation, in the cases treated successfully in this manner. Minin, of St. Petersburg, states that the visible chemical frequencies of the spectrum from the blue to the ultra-violet, by acting on the vasomotor nerves, are sedative and analgesic in nature.

## APPENDIX.

### ON DEATH BY ELECTRICITY, AND ON RESUSCITATION OF PERSONS SHOCKED BY ELECTRICITY.

Much has been written lately about death in the electric chair. It has been said by some physicians that the victim is not killed but merely stunned by the electric current, only to die later by the pathologist's knife, or by the quicklime in which the bodies of murderers are buried when interment is under the direction of the prison authorities. The most noteworthy fact about the controversy is that the statements are sometimes made by men who know absolutely nothing about the action of the electric current on the human body; men who do not know the difference between a volt and an ampère. This latter fact is proved by the statement that a current of so many volts does or does not kill. We sometimes read of a man receiving in his body the "full charge"—as it is put—of 2300 volts and still living to tell the tale. As a matter of fact the man did not have 2300 volts pass through his body; he merely had such strength of current pass through some part of the body, such as a hand or a foot, and then, almost at once, the circuit was broken.

The ampèreage especially is to be considered when we are figuring as to the likelihood of death from an electric current. The ampèreage is found by dividing the voltage by the resistance

in ohms. This gives us  $C$  (current)  $= \frac{\text{Voltage}}{\text{Resistance}}$  or  $C = \frac{V}{R}$

Now the unit of current strength is the ampère; the unit of pressure or driving force, called also the voltage, is the volt; the unit of resistance is the ohm.

We have  $A$  (Ampères)  $= \frac{\text{Volts}}{\text{Ohms}}$ , *i.e.*,  $\frac{1800 \text{ volts}}{600 \text{ ohms}} = 3 \text{ ampères}$ .

Resistance does two things: it reduces ampèreage and it produces heat.

If a current is started at a power-house at Broad and Chestnut streets to be sent to Tenth and Chestnut streets, how much of this current will reach its destination? This will depend on what resistance is offered to the passage of the current. In the example cited, if a current of 1800 volts be started and meet a resistance of 600 ohms, we will have a current strength of 3

ampères for C (in ampères) equals  $\frac{\text{Voltage (1800)}}{\text{Resistance (600)}} = 3$

ampères. If a current of 2000 volts be applied to a human body whose resistance is 2000 ohms, we shall have a current strength of one ampère. It is now important to remember that the resistance of the human body varies very much, being usually from 3000 to 5000 ohms, with a 15-volt current, but in exophthalmic goitre the resistance has been found to be between 500 and 1500 ohms.

We should remember also that parts exposed to the atmospheric air offer a greater resistance than do those that are always covered; that a dry skin offers more resistance than a perspiring or moist skin; and that the epidermis offers a much greater resistance than do other parts of the body. So, we say the resistance of a man's body is the resistance of the epidermis. But the resistance decreases after the electrodes have been in position for a short time, a fact easily proved by applying the electrodes from a galvanic battery to the surface of the body. At first, the patient will say he feels no current, which simply means that the resistance of the epidermis has not yet been overcome. Suddenly, he will say that now he feels the electricity. When the electrodes of the electric chair are applied, the resistance of the human body must be reckoned with, and we must also remember that the ampèrage will become greater as soon as the resistance of the epidermis is overcome. The resistance of the epidermis may at first be as high as 100,000 ohms; but, after a short application of the current, the resistance falls to a point known as the constant minimum. When this constant minimum is reached, the resistance will not decrease, no matter how much longer the current flows.

The body resistance may be measured by means of a Wheatstone bridge, or by means of the substitution method, with the aid of a dead-beat galvanometer. The resistance of the epidermis is much more easily overcome by the faradic and by the static currents than by the galvanic.

It was shown, from the studies of d'Arsonval, that a current of very high intensity would cause death instantly either through the disruptive action of the current or through the sudden heat-production which causes tissue alteration and disintegration. A current of lower intensity would cause death by asphyxiation, due to paralysis of the respiratory centre in the medulla. There is a standing rule in nearly all power-houses and electric light stations to use artificial respiration for several hours in every case where a person has received a severe electric shock. Cunningham has shown by experiments on dogs that this respiratory failure following an electric shock is but a secondary development. He found that in all cases death was caused by fibrillation of the heart muscle, and that the respiratory paralysis was simply an inhibition which lasted only so long as the current was flowing.

If a current of very great electro-motive force be passed, even for a long time, only through the brain and upper cord, it is possible to revive the patient by means of artificial respiration. If, however, the heart be brought into circuit, artificial respiration will prove of no avail. When the heart is in circuit the blood-pressure is reduced immediately on the introduction of the current and will not be re-established when the current ceases to flow. In this case artificial respiration will cause respiratory movements to re-assert themselves, thus proving that the respiratory centre is intact; but these movements will continue for only a short time, when the respiratory centre will refuse to act because of the anemia produced by the stoppage of circulation.

So it may be safely said that those cases in which the current merely passes through the head without bringing the heart in circuit, offer a very good chance for the use of artificial respiration. In the case of accidents in a power-house or electric light station, we do not know whether the heart has been in circuit or not, so it behooves us to give the victim the benefit of



the doubt and continue artificial respiration for at least two hours.

It may be said from the experiments of Cunningham that when the head, the heart, and the whole body are in circuit we will have (1) paralysis of the heart, due to fibrillation of the heart muscle; (2) inhibition of respiration, due to action on the respiratory centre in the medulla; (3) anemia of the brain producing syncope; (4) death.

In executions by electricity death should be caused as quickly and as painlessly as possible. It has been found that alternating, intermittent, and coarsely pulsatory currents cause death much more rapidly than does the direct current. Electrocution by means of the electric chair is accomplished now by arranging the electrodes so that death is caused (1) by cardiac paralysis; (2) respiratory inhibition; (3) anemia of the brain; (4) molecular disintegration of the tissue.

This subject has been studied very carefully by expert electricians and physicians the most distinguished of whom is Professor E. A. Spitzka of the Jefferson Medical College, Philadelphia. The following detailed description of the methods pursued in electrocuting criminals is taken, with permission, from the article of Professor Spitzka in the Proceedings of the American Philosophical Society, Volume XLVII, 1908:—

“**Electrocution**—or more properly electrothanasia—compounded from ‘electro-execution,’ is the popular name for the infliction of the death penalty by passing through the body of the condemned a current of electricity of sufficient intensity to cause death. The method was first adopted by New York State in 1888, by a law which became effective on January 1, 1899, and which provides how many persons may witness the execution, that a post-mortem examination of the body of the convict be performed, and that the body, unless claimed by relatives, be interred in the prison cemetery with a sufficient quantity of quicklime to consume it.

“The apparatus consists of a stationary engine, an alternating dynamo capable of generating 2000 volts, a ‘death chair’ with adjustable head-rest, binding straps, and adjustable electrodes. At Trenton, a 2400-volt current is taken from the

public service wire and lowered to the desired tension by a rheostat.

“The voltmeter, ammeter, and switch-board controlling the current are located in the execution-room; the dynamo-room is communicated with by electric signals. Before each execution the apparatus is thoroughly tested. When everything is in readiness, the criminal is brought in unfettered and usually unassisted, and is seated in the chair. His head, chest, arms and legs are secured by broad straps; an electrode, thoroughly moistened with saturated salt-solution, is affixed to the head and another electrode is attached to the calf of one leg, both electrodes being molded so as to assure good contact. The head is not shaved, as is popularly thought.

“The application of the current is usually as follows: The contact is made with a high potential current—1,800 volts—for from five to seven seconds; the current is then reduced to from 200 hundred to 250 volts and there maintained for thirty seconds; the current is again raised to the high voltage for from three to five seconds, again reduced to the low voltage and maintained for sixty seconds, at the end of which time the current is raised to the high voltage for a few seconds and the contact is then broken. The ammeter usually shows that from 7 to 10 ampères of current have passed through the criminal’s body.

“A second or even a third brief contact is sometimes made, partly as a precautionary measure, but more to abolish completely the reflexes in the dead body.

“The physician in charge observes the respiratory movements of the prisoner and signals to the electrician at a moment when the lungs contain the minimum quantity of air. At the moment that the contact is made the criminal’s body stiffens in a state of tonic muscular spasm, restrained by the straps. This spasm abates somewhat as the voltage is reduced, again to attain its maximum with each raise of voltage. When the current is interrupted the body collapses completely. An examination by the physicians usually fails to elicit any signs of life. Occasionally, there is heard a turbulent, incoördinate, accelerated heart-beat, but apparently limited to the auricular chambers of the heart. In only two cases was there any respiratory effort and this

was limited to a single contraction of the thoracic respiratory muscles. An additional brief contact or two regularly abolished these reflex phenomena.

“The reason for making the contact at the moment that the convict has expired air from his lungs in the natural course of his breathing is this—and it will explain why certain witnesses of the first electrocution thought that life still existed in Kemmler’s body (William Kemmler, the first criminal to suffer the death penalty by electricity, was electrocuted on August 6, 1890, in Auburn Prison in New York State). It must be recalled that there is created a terrifically powerful spasmodic contraction of all muscles, including the sphincters and the glottis. The closure of the glottis confines whatever air may be in the lungs; upon interrupting the current the body becomes entirely limp, the glottis partly relaxes, the thorax collapses and the contained air rushes through the partly closed glottis. A sound resembling a sigh or half groan may be thus produced upon the body of any dead animal; a little mucus present augments the sound into a gurgle. It is no wonder that inexperienced persons then believe life still to be present.

“The death is undoubtedly painless and instantaneous. The vital mechanisms of life—circulation and respiration—cease with the first contact. Consciousness is blotted out instantly and the prolonged application of the current as it is usually practiced by Mr. E. F. Davis, the State Electrician, of New York, ensures the permanent derangement of the vital functions so that there could be no recovery of these. Post-mortem discoloration, or lividity, often appears during the first contact. The pupils of the eyes dilate instantly and remain dilated in death.”

#### COMPARISON OF THE NEW METHODS WITH THE OLD.

“The preparations for the execution were always swiftly conducted. Upon this point comparison favors neither method. But after the drop through the trap-door the ensuing seconds and even minutes bear a different tale. In nearly all cases the heart beats for about thirteen minutes. In no case could fracture

of a cervical vertebra or rupture of ligaments be determined in the ordinary examination.

“In one case only was there no movement of the body after the drop, although the heart beat the usual length of time. This prisoner, a Chinaman, apparently died in syncope or of apoplexy. In others the unconsciousness produced by the first shock of the drop appeared to abate and in several instances there were conscious—or at least semiconscious—efforts at respiration, efforts to reach the neck where the choking sensation was unbearable, efforts at reaching for a support for the feet manifested by such vigorous efforts that several witnesses fainted at the sight.

“They veritably ‘danced upon the air’ until the asphyxia (apnea) became so profound as to blot out consciousness, apparently after one or one and one-half minutes in some cases.

“The most commonly found lesion was an oblique opening of the sutures of the skull, so that one portion of the skull, represented by the occipital and temporal bones, becomes pulled aside from the other portion, represented by the facial part of the skull and the other temporal bone. The basilar suture in most cases was also disunited. The skulls all gave evidence of blood staining.

“This remarkable finding of evidence dating about 2,000 years back, prompted the writer to examine the head and neck bones of five individuals executed by hanging and sent to the Jefferson Medical College for dissection. In not a single instance could there be found a fractured cervical vertebra or a separation of any cranial suture. Death had ensued through strangulation.

“The Newgate Calendar and other criminal records are full of instances in which the rope broke and the condemned had to be re-hanged, and even cases where the head was severed from the body. Furthermore, there are not a few authentic cases of resuscitation and total recovery after hanging.”

Compared with hanging as well as other methods, electrocution is the most humane and scientific method of inflicting the death penalty because of its efficiency, quickness and painlessness, and it should be adopted by every State in the Union. The executions should take place in a building remote from the penitentiaries where other convicts, more or less susceptible to

reformation, are confined. The erection of scaffolds in prison corridors or the knowledge on the part of other convicts that an electrocution is in progress has a bad, even brutalizing effect upon them.

It is unscientific to draw a parallel between the case of a person who comes in accidental contact with a live wire, and a case of legal electrocution. In the first instance the electricity may have passed through the man's clothing, the skin may have been dry and thus offered greater resistance, or the contact may have been broken almost immediately as is proved by the fact that the victim is often at once thrown away from the wire. In the legal electrocution every effort is made to decrease the natural resistance of the human body. This is accomplished by using sponge electrodes that have been saturated with a saline solution. The electrodes are placed on the head and leg so as to bring the head, the heart and the whole body in circuit and so cause death as has been already explained.

#### METHODS OF ASSISTING PERSONS INJURED BY ELECTRICITY.

Before describing methods of resuscitation, it is well to speak of the strength of current encountered in different systems, and also to explain the manner in which electric shocks may be received. Not all wires carry the same amount of current. The writer gives approximately the strength of current carried by wires in the following systems:—

Incandescent lighting systems, 110 to 220 volts.

For mechanical work, 110 to 500 volts.

Trolley roads, 500 to 800 volts. (This includes the third-rail road.)

Telegraph and telephone systems use a weak current—4 to 30 volts—but we must remember that these wires may at any moment fall upon or touch heavily charged wires and thus cause great injury to anyone using the instrument.

We must also remember that electric companies sometimes cause electricity to be transmitted long distances, and that these currents may be from 10,000 to 70,000 volts. Usually apparatus

for carrying high-tension currents is indicated by some danger signal.

There are several ways of obtaining an electric shock, such as (1) by touching one pole of a "grounded" circuit; (2) by touching both poles of a circuit; (3) by receiving what is known as a "shunted" circuit, by touching a wire in two places while the person is insulated, or protected, from the floor; (4) by having currents of high tension jump across the intervening air-space and producing shock without the wires being actually touched. In (3) the current takes the path of least resistance—through the wire—and so does not, as a rule, cause much injury to the human body because of its natural high resistance.

It is well to remember that a wet floor is more dangerous than a dry one, and that the floor of cement in the modern steel-framed building is more dangerous than is the floor of wood in a wood-framed building. Moisture at the contacting portions of the body, as moisture on the hands or dampness on the floor, lessens the resistance of the human body to the flow of electricity and thus greatly increases the danger. We should remember that a metal-handle tool held in the hand will be more dangerous, if touched to a live wire, than if the hand alone were touched to the wire; the tool, in this case, will cause the current to pass into the body and so through the whole system.

If we find a person still in contact with a live wire, we should at once attempt to free him in one of the following ways: If possible, we should at once shut off the current by means of a switch; if this cannot be done, we may be able to break the circuit by breaking the wire by means of a piece of dry wood—as a cane without metal on it, or by throwing a dry rope over the wire and pulling the wire away from the body; or, the wire may be cut by using pliers, having insulated handles, or by handling the pliers with heavy rubber gloves. We should be very careful when we cut the wire as the severed ends sometimes produce an arc which may cause much damage to bystanders. In some cases the contact may be broken simply by pushing dry clothing under the victim's body with the aid of a dry stick of wood, or by lifting the victim's body from the ground. In attempting the latter method, we should remember to observe one of these

precautions: to pull on rubber boots or shoes; to wear rubber gloves; to stand on a dry board or on dry clothing; or, to wrap the hands in dry clothing. We should always grasp the victim's body by means of his clothing and never by the uncovered portions of his body. We should be careful, as we lift the body of the patient, not to carry it toward any metallic object while one part of the body is still in contact with the wire. As soon as the patient is freed from the current, we should place the head higher than the rest of the body and at once begin artificial respiration. Massage over the region of the heart and the faradic current—with one electrode over the heart and the other on the neck—help greatly in reviving the patient. Adrenalin, as a means of raising blood-pressure, has been warmly advocated by some and just as much condemned by other writers. Dr. Hare, of Jefferson Medical College, states that a rise of blood-pressure will follow the internal use of adrenalin owing to the stimulating effect on the vasomotor centre. Venesection, the application of the Leduc current—a direct but intermittent current of a duration of one-tenth of a second every two seconds, with a strength of 14 volts and with 110 alternations—and also lumbar puncture have all been highly recommended by different authorities.

The body of the patient should be examined for burns, arborescent tracings—produced by an effusion of blood as the electric current passes through the blood-vessels—fractures, or other physical injury.

We should not forget that patients apparently dead for hours, after an electric shock, have been revived by long continued treatment.

It may seem paradoxical to say that, in attempting to resuscitate persons who have been shocked by electricity, we should use electricity. We should use a strong faradic current applied as directed for artificial respiration and at the same time, when possible, have another physician use the high-frequency current from a glass vacuum surface electrode. We should not allow the surface electrode to touch the skin, as we wish to cause sparks, which will be produced by holding the vacuum electrode at a short distance.

We should not use galvanism. Recently the daily papers gave an account of a man who had been revived by means of the galvanic current after receiving the full force of a very heavily charged wire. Such a statement shows gross ignorance of the action of the galvanic current.

D'Arsonval states that criminals may be revived, after electrocution in the electric chair, by employing the following method:—

“One electrode from a faradic battery is placed over the phrenic nerve on the outer edge of the lower part of the sterno-mastoid muscle, a point straight down from the topmost point of the ear to meet a line one-half way between the larynx and the top of the clavicle; the other electrode at the insertion of the diaphragm into the thoracic cavity.

“Do not be afraid of having the current too strong. Make and break the contact, by means of a rheotome or by an interrupting handle twenty times per minute. If there is any possibility of resuscitating the patient, the above method will do it. One minute the diaphragm is tetanically contracted and at the next instant relaxed.”

The same method may also be used to produce respiration in cases of drowning, opium poisoning, asphyxia, and in the new-born infant.

It is well to remember that burns produced by electricity are due to chemical action and to heat. Their treatment is the same as that for burns from almost any cause, excepting that ointments are not well borne. It is also a fact that a moxa requires a longer time for healing than does any ordinary burn.

The sequelæ of an electric shock may be: quick recovery, gradual recovery, traumatic hysteria with all that this term implies, traumatic neurasthenia, partial or even complete paralysis which may become permanent, hysterical paralysis, blindness, and even insanity. The writer saw a case at Jefferson Hospital, in the service of Dr. Dercum, in which a shock from lightning was soon followed by amyotrophic lateral sclerosis.



**TABLE OF DIFFERENTIATION.**

The following table will aid in differentiating anterior poliomyelitis, a peripheral lesion, and a case of lead palsy. We should never rely on the electrical tests alone, but should get a complete history, as far as we are able, of the patient's previous condition. Of course, it is understood that many nervous diseases do not require an electrical examination to assist in arriving at a diagnosis; the accompanying table is shown merely to demonstrate that reaction of degeneration is present in all three cases, and so the electrical test alone would be of no value in forming a diagnosis. Sensory changes are present only in the case of peripheral lesion.

	HISTORY.	MUSCLES INVOLVED.	TROPHIC CHANGES.	R. D.	MUSCULAR ATROPHY.
LEAD PALSY.	Onset slow; blue line on the gums; lead exposure.	All the muscles except the Supinator Longus; usually bilateral.	Slight	Present	Present
ANTERIOR POLIOMYELITIS.	History of slight fever; onset sudden.	All of the muscles; usually bilateral.	Slight	Present	Present
PERIPHERAL LESION.	History of injury, or of pressure on a nerve; onset sudden.	All of the muscles; unilateral.	Marked	Present	Present

**TEST FOR DEATH.**

The electrical current affords a means of determining death. It is now known that the muscles, after cadaveric rigidity has set in, do not respond to electric stimuli. The faradic current will cause, when death has occurred, muscular contractions until a short time before post-mortem rigidity occurs. The faradic stimulus is lost first and the galvanic stimulus soon after. We may be enabled to approximate the time at which death occurred, for, if we find any response to either the faradic or the galvanic current, we know at once that post-mortem rigidity has not yet obtained. If we find no response to either current we may be positive that life is extinct.

No person should be buried as long as the muscles contract when stimulated by either the faradic or the galvanic current.

If the electrical test were always applied before a death certificate was signed, there would be absolutely no possibility of a person being buried alive and the public would soon lose the morbid fear of such an occurrence.

### FULGURATION.

Fulguration, from "fulgur" signifying lightning, really means a method in which the sparks come and go in the manner of lightning. It is well to remember that the disruptive electric spark has been known for at least one hundred and fifty years. Fulguration is but a new name for our old friend, the abrupt spark.

However, the use of the spark in the treatment of malignant tumors is of recent origin.

Much has been written lately concerning fulguration, or the electro-surgical method, for the treatment of malignant tumors. Some enthusiasts even go so far as to state that fulguration (which is essentially the projecting on the operative field of a shower of sparks from an alternating current of high tension and of high frequency) will entirely dispense with the knife of the surgeon. This, of course, is not true.

The unsuspecting public has had foisted upon it so many so-called cancer cures, that the laity as well as the medical profession must necessarily experience a feeling of scepticism when a new "cure" is advocated even by a physician.

In 1907 Dr. De Keating-Hart gave to the above method the name of fulguration.

The method should be carried out in two stages, one of which is the removal by the surgeon of every possible portion of the tumor, and the other of the fulguration or electric stage. The first stage is necessarily the more important stage although at one time some electro-therapists considered the surgical end of but secondary importance.

Fulguration accomplishes two things, first, the *immediate* destruction of any portions of the tumor left by the surgeon, and, secondly, the setting up of a *lasting reaction* in the surrounding tissues. This last is what constitutes the real value of the method.

The patient is placed on a poor conductor, such as a table without metal parts. Formerly a series of sparks were seen when the electrode was brought near to the patient's body, the length of these sparks being easily controlled by the operator.

The current employed is an alternating current of about three hundred thousand volts with a periodicity of one million per second.

It is now known, from the studies of Keating-Hart, that the heating action of the sparks should be avoided. This heating is prevented by using special electrodes, so arranged that the metallic electrode is placed in a tube through which passes cold, sterilized air.

Local or general anesthesia should be employed as fulguration is very painful. Chloroform is the best general anesthetic. We must not forget that ether vapors may catch fire from the electric sparks.

In the early stages where the surgeon is enabled to remove in one mass all that should be removed (as in an early case of cancer of a breast), fulguration should *not* be employed.

It is only in cases in which the surgeon is dubious about being able to remove the tumor except in fragments and in cases that the surgeon counts as inoperable, that fulguration is indicated.

In inoperable cases we have a fair chance of believing that fulguration will delay, for a time at least, the fatal issue. Fulguration is known to have a greater destructive action on the epithelial cells than on the connective tissue. It destroys epithelial cells, but cannot be said to have any special action on cancerous cells and shows no particular predilection for the tumor cells.

We would be practicing a cruel deception if we propose to patients the method of fulguration as an alternative for the classical treatment by means of the knife in early cases of cancer. Such deception not only gives the patient a false sense of security, but also delays the operation perhaps to such date when the operation is no longer feasible.

The most suitable cases for fulguration are the tumors of the breast and face, although cancer of the rectum and of the bladder have been treated with very gratifying results.

**The Results.**—1. Fulguration, through vaso-constriction, immediately causes cessation of surface hemorrhage.

2. Following fulguration there is poured out a profuse serous exudation which seems to have toxic properties.

3. Mortification of the tissues is found following fulguration. We should remember that, while destruction takes place immediately, this destruction is very superficial being only a few millimeters in thickness.

4. This layer of dead tissue will in a few days come away and leave underneath very active granulation. Fulguration also produces a subsequent anesthetic effect.

**Dangers of Fulguration.**—In considering the dangers of fulguration we should not forget that the cases usually treated by fulguration are often the cases already doomed beforehand—cases that have been refused by the surgeons.

Fulguration increases the time of operation; the wound cannot be united because of the tissue destroyed and also because the toxic lymph, which subsequently forms, must be allowed a free exit; infection sometimes is seen, probably from a current of germ-laden air being used to cool the electrode. Sparks applied to the thorax have been known to cause failure of respiration and later to stop the heart. We must not forget that the pneumogastric nerve should never be fulgurated. No physician should be misled into believing that fulguration is a harmless treatment.

Death has been seen to follow a few hours after fulguration, but this is usually seen after extensive operations on cachectic patients.

It seems to the author that, all things considered, Keating-Hart has devised a palliative treatment of cancer, which is second to surgical operation but is in advance of the treatments by X-ray and radium. The old, old formula—*an early diagnosis, an early and, as far as possible, a complete operation*—is still the best to employ with our present knowledge of cancer.

**ELECTRIC SLEEP.**

Much attention has been attracted lately—because of the novelty of the idea—by the articles published in the lay press on the employment of electricity to produce general or local anesthesia. It has been asserted that electricity is to supplant ether and chloroform in the production of general anesthesia.

Erb, in 1867, showed that electricity could be made to pass into the brain-substance and act on a galvanometer placed within the brain after the skull had been opened.

Fritsch and Hitzig at a later date showed the excitability of the brain to the electric current. Their experiments were, like those of Erb, carried on by first trephining the skull so the current might be applied directly to the brain-substance.

W. F. Hutchinson, in 1893, proposed the theory that anesthetic properties were possessed by induced current vibrations of extreme rapidity, but his views were not well received.

Monsieur Stéphane Leduc (PROFESSEUR DE PHYSIQUE A L'ÉCOLE DE MÉDECINE DE NANTES) produced in 1902 a condition to which he gave the name of "electric sleep," this condition being very similar to that of drug narcosis. Leduc found that the best method of electrical testing for muscular contraction was the employment of a current in which the interruption occurs one hundred times per second, and in which were produced waves lasting one one-thousandth of a second with a repose lasting nine one-thousandths of a second. From this discovery Leduc devised his method of producing electric sleep. He said that he had produced "instantaneously and without pain complete inhibition of the cerebral centers, leaving the respiratory and circulatory centers intact, thus causing a condition characterized by the loss of voluntary movements and the presence of general anesthesia." It should be remembered that Leduc was the first to demonstrate that the electric current will penetrate an intact cranial vault.

Leduc employed a wheel interrupter—such as has for years been employed in electrical work—arranged in such a manner that the brain received successive shocks. Each shock lasted for

but one one-thousandth of a second duration and was followed by a passive period of nine one-thousandths of a second.

Two brushes are placed directly opposite each other, one brush being fixed and the other movable on a scale. If the movable brush is placed at the point marked ten on the scale and we have the segments passing one hundred times each second we will have the current *active* one one-thousandth of a second and *passive* for nine one-thousandths of a second. By this means Leduc was enabled to deliver a series of successive shocks each second. The length of time of each shock and the time in which no current was passing were carefully regulated.

Since Leduc's work along these lines, several experiments have been carried on by employing the Leduc current on dogs, rabbits and even on man. While the experiments on dogs and rabbits have been to a certain extent successful (as has been shown by cutting down on the large nerve trunks and clamping them with hemostatic forceps) the same cannot be said of the experiments on man. Dudley Tait and Raymond Russ conducted a long series of experiments which prove the above statements to be true.

There can be no doubt but that the medical profession would gladly welcome electric anesthesia if the same could be easily and safely produced in the human being. When we remember that one investigator states that no physician is competent to practice electric anesthesia unless he has had two years' daily experience in this work, we may easily understand that very few physicians will qualify for the position. When we remember that special apparatus must be employed and that, even with such apparatus, any sudden and rapid deviation in current-strength may cause death, we need hardly hope at the present time to see electric anesthesia supplant ether and chloroform in our hospitals.

We should remember that electric anesthesia has its dangers as failure of respiration may quickly follow any sudden change in current-strength; if the electrodes are changed and placed so that the current passes transversely through the skull, vertigo will be produced.

The Leduc current is known to produce in animals anal-

gesia, epilepsy, respiratory and cardiac inhibition, and electrocution. We should not forget how closely these conditions may be related.

Experiments on animals have demonstrated that the Leduc current will at times cause rigidity and tremors of the rear limbs, increase of blood-pressure, absence of pupillary contraction and exaggeration of the superficial reflexes, none of which are found in the condition ordinarily described and accepted as sleep. It may also be said that none of these are seen in anesthesia produced by ether or chloroform.

The principle of electric anesthesia is this: The apparatus employed is the one perfected in 1908 by Gaiffe of Paris. This apparatus consists of a system for rapidly interrupting a current of low tension flowing in one direction, measuring the number of interruptions per minute and regulating the ratio of the current's active period to its passive period. The current passes from the battery to a wire rheostat. From the rheostat the *positive* current goes through an interrupter, is measured by a milliampèremeter and finally reaches the terminal *positive* electrode. It is now thought that better results follow the placing of the interrupter on the positive wire. The negative wire passes directly to the patient. A current is taken from a storage battery and passes through a metal wheel upon the rim of which are regularly recurring points of insulation. As the wheel rapidly revolves and the level conveying the current comes in contact with this rim, the current meets the alternating sections of metal and insulation and so becomes a broken current. Sometimes no voltmeter is employed, as such an instrument is not thought necessary, but from five to ten volts of current are said to be required to produce electrical anesthesia in animals and from fifty to eighty volts to produce the same condition in man.

A space on the head just above and between the eyes is denuded of hair; the same is done at a space on the back near the point where the nerve trunks to the hind legs emerge. If any abrasions are noticed, they should be covered with flexile collodion.

The positive wire is connected to the animal's head by means of a zinc or copper electrode, while the negative wire is connected to the electrode placed over the lumbar region. The electrodes should be covered with cotton and well moistened. The operator must watch the animal closely and at the least sign regulate the strength of current. It has been said that a fraction of a volt too much will cause the animal great pain, while a fraction too little may bring the animal back to full consciousness in an instant and in the very midst of an operation. One investigator states that animals under the influence of electric anesthesia have been known to raise the head, look about and then lie quiet until the completion of the operation. This evidently is to be interpreted to mean that the dog raised its head, looked about and (approving the method and manner of operating) quietly lay still until the operation was completed. The fact of raising its head while under electric anesthesia should be sufficient to provoke criticism of the method. Think of what might have happened if the dog (after raising its head and viewing the operation) had decided that a faulty technic was being employed! Imagine, if you can, an operation on the brain in which the patient was allowed to raise his head whenever he felt so inclined! Every physician knows that frequently ether or chloroform is administered in order to relax the muscles and to keep the patient from moving about. Our friends—the anti-vivisectionists—say that the animal suffers during experimentation because not properly anesthetized, but any sane person knows that no animal will lie quiet while being tortured. If the animal is not quiet and relaxed, no experiment could be performed.

Dr. Brewer found from experiments performed on dogs while under the influence of electric anesthesia, first, a period of excitement; second, a period of muscular spasm; third, often complete surgical anesthesia; and fourth, in a number of instances—death.

Tait and Russ say of electric anesthesia that its practical value in experimental animal surgery is almost *nil*.





## SUMMARY OF ELECTRICAL TREATMENT.

---

- Abscess.** Open abscess by means of galvanic acupuncture.
- Acne.** High frequency current—incandescent light—arc light.
- Adenitis.** Galvanic current—high frequency current.
- Adhesions, Pelvic.** Morton wave current—sinusoidal.
- After Pains.** Secondary faradic.
- Alopecia.** Static crown breeze—negative galvanic.
- Alopecia Areata.** High frequency current—ultra-violet light—arc light.
- Amenorrhoea.** Faradic current—galvanic to spine—electric light bath.
- Analgesia.** Dry faradization—static spark—high frequency current.
- Anemia.** Static electricity (Morton wave current and static spark)—spinal galvanization—Bachelet magnetic wave.
- Anemia, Cerebral.** Negative static head breeze.
- Aneurism.** Electrolysis.
- Angina Pectoris.** If there be high blood-pressure, high frequency current—Bachelet wave.
- Angioma.** Galvanic current—high frequency current.
- Ankylosis.** Negative galvanic—sinusoidal.
- Aphonia, Hysterical.** Faradism—high frequency current.
- Arterio-sclerosis.** High frequency current (auto-condensation). *Never* the static current.
- Arthritis, Acute.** Positive galvanic—high frequency current.
- Arthritis, Chronic.** Morton wave current—sinusoidal—electric massage.
- Asphyxia.** Faradism—high frequency vacuum electrode.
- Atrophy of Optic Nerve.** Negative galvanic current—high frequency vacuum eye electrode.
- Baldness.** See alopecia.
- Bronchitis.** Electric light bath—high frequency vacuum electrode.
- Callosities.** Static spark—high frequency vacuum electrode.
- Cancer.** Fulguration *following the surgeon's knife.*
- Carbuncle.** Positive galvanic with zinc needle—electro-cautery—pointed vacuum electrode with high frequency current.
- Catalepsy.** Faradism—high frequency vacuum electrode.
- Chalazion.** Electrolysis.

**Chancroid.** High frequency pointed vacuum electrode.

**Chilblains.** Foot in water connected to positive galvanic.

**Chloasma.** Negative galvanic to spots.

**Chlorosis.** High frequency vacuum electrode to spine—Bachelet wave.

**Chorea.** Bachelet wave current—Morton wave current—high frequency vacuum electrode down spine.

**Cicatrix.** Negative galvanic—sinusoidal.

**Colitis, Mucous.** Faradism—electric light bath—high frequency vacuum electrode to abdomen.

**Conjunctivitis.** Weak positive galvanic current—high frequency eye electrode.

**Constipation.** Morton wave current—sinusoidal—high frequency vacuum electrode—electric massage—electric light bath.

**Convalescence.** Electric light bath—static current—Bachelet wave.

**Coryza.** High frequency vacuum electrode—inhalations of ozone.

**Cramp, Writer's.** Sinusoidal current—high frequency vacuum electrode—Fränkel method for incoördination.

**Cystitis.** Bachelet wave.

**Delirium Tremens.** Bachelet wave.

**Diabetes Mellitus.** Sinusoidal—high frequency current—electric light bath.

**Diphtheria.** Galvanic and high frequency currents for resultant paralysis.

**Dysmenorrhea.** Infantile uterus—Faradism. Atresia or stenosis—negative galvanic. Membranous—negative galvanic. Congestive type—Morton wave current—Bachelet wave.

**Dyspepsia, Nervous.** Electric light bath—high frequency vacuum electrode over stomach and abdomen—Bachelet wave.

**Eczema.** High frequency vacuum electrode—arc light.

**Epilepsy.** Bachelet wave.

**Epithelioma.** Fulguration following knife.

**Fissure in Ano.** High frequency vacuum electrode.

**Freckles (Lentigo).** Negative galvanic—high frequency pointed vacuum electrode.

**Furuncle.** Electro-cautery—high frequency pointed vacuum electrode.

**Galactorrhea.** Positive galvanic, avoiding nipple.

**Gastritis, Chronic.** High frequency vacuum electrode over region of stomach—Bachelet wave.

**Glands, Tubercular.** Cataphoresis with iodine, by means of negative galvanic pole or the high frequency vacuum electrode. Arc light.

**Goitre, Simple.** Negative galvanic—Morton wave current.

**Goitre, Exophthalmic.** Cataphoresis, with iodine on negative galvanic pole—cataphoresis, with iodine on a cataphoric high frequency vacuum electrode.

**Gout.** Electric light baths—high frequency vacuum electrode to painful joint—Morton wave current.

**Herpes Zoster.** Positive galvanic—high frequency vacuum electrode.

**Hemiplegia.** See "Paralysis."

**Hiccough.** Faradism (secondary current); if hysterical in origin, use Bachelet magnetic wave current.

**Hypertrichosis.** Electrolysis (negative galvanic pole). Do not employ X-rays.

**Hysteria.** If there is high blood-pressure, use auto-condensation; if the blood-pressure is low, use static current.

**Incontinence of Urine.** Faradization.

**Insomnia.** High frequency vacuum electrode over head and spine—Bachelet wave.

**Keloid.** Negative galvanic pole.

**Laryngitis.** High frequency vacuum electrode—blue light treatment.

**Lentigo.** See freckles.

**Leucorrhœa.** High frequency vacuum electrode.

**Locomotor Ataxia.** Static electricity—high frequency surface electrode—electric light bath—Fränkel treatment.

**Lumbago.** Incandescent light—electric massage.

**Lupus.** Arc lamp (violet and ultra-violet rays).

**Melancholia.** Bachelet wave current.

**Menorrhagia.** Galvanism.

**Myalgia.** Electric light bath—high frequency vacuum electrode—electric massage.

**Nephritis.** Electric light bath—Bachelet wave current.

**Neuralgia.** High frequency vacuum electrode—Bachelet wave—positive galvanic—static current.

**Neurasthenia.** Same treatment as for hysteria, *q. v.*

**Neuritis.** Positive galvanic—high frequency vacuum electrode—cataphoresis by means of galvanic current.

**Ovarian pains.** If hysterical, use secondary faradic.

**Papillitis.** See atrophy of optic nerve.

**Paralysis Agitans.** Static current—sinusoidal—Bachelet wave—high frequency current.

**Paralysis, Diphtheritic.** Negative galvanic—high frequency vacuum electrode.

**Paralysis, Erb's.** Galvanic—combined current—high frequency—sinusoidal.

**Paralysis, Facial.** Galvanic current—sinusoidal current—faradic current—high frequency current—combined current—electric massage.

**Paralysis, Lead.** Same as facial—electric light bath.

**Pharyngitis, Acute.** Same as laryngitis.

**Pharyngitis, Follicular.** Electro-cautery—high frequency vacuum electrode.

**Poliomyelitis, Chronic Anterior.** Galvanic current—combined current—high frequency vacuum electrode—electric massage.

**Prostatic Hypertrophy.** Bottini's operation—static electricity—high frequency vacuum electrode.

**Pruritus.** Positive galvanic—faradic current—high frequency effleuve.

**Psoriasis.** Arc light—high frequency vacuum electrode.

**Pterygium.** Negative galvanic, about three m. a.

**Raynaud's Disease.** Galvanic—sinusoidal—high frequency vacuum electrode.

**Sarcoma.** See treatment for carcinoma and epithelioma.

**Sciatica.** Positive galvanic—faradic current—static current—high frequency current—incandescent lamp.

**Stricture of Urethra.** Negative galvanic, with olive-pointed electrode.

**Tattoo Marks.** Galvanic current (electrolysis).

**Tic Douloureux.** Galvanic current—high frequency vacuum electrode.

**Torticollis.** Galvanic current—electric massage—incandescent lamp—high frequency current.

**Trachoma.** Positive galvanic with copper electrode.

**Uvula, Elongation of.** Electro-cautery.

**Vomiting of Pregnancy.** Faradic current, avoiding region of the uterus.

**Warts.** Fulguration—cataphoresis of magnesium by means of the galvanic current.

## GLOSSARY.

---

**Activity, Unit of.** Rate of doing work. One unit of work, performed in one unit of time, equals one unit of activity.

In the C. G. S. (centimeter-gramme-second) system, the unit of activity equals one erg per second.

The practical unit in the same system is the watt, equal to one joule per second.

**Accumulator.** An apparatus for storing electricity, such as the Leyden jar or the storage battery.

**Adherence.** Steady attachment. Attraction of unlike magnetic or electrostatic charges.

**Ampère.** The unit of current strength.

**Ampèremeter or Ammeter.** An instrument for measuring current strength in ampères.

**Anelectrotonus.** See Electrotonus.

**Anion.** Ions are the elements into which a substance is divided by electrolysis. The *Anion* collects at the positive pole.

**Anode.** The positive pole; the way by which electricity enters.

**Annunciator.** An electro-magnetic indicating device.

**Armature.** An iron bar attached to the poles of a magnet to preserve its magnetism.

**Attraction, Magnetic.** The attraction which a magnet exerts over other bodies.

**Base.** The part of a battery upon which are fastened the coil, posts, and switches.

**Battery.** The complete electrical apparatus, although the cells are sometimes called the battery.

**Battery, Electric.** This is a general term given to the combination of two or more sources of electricity—two or more voltaic cells properly connected, two or more dynamos properly wired, or two or more Leyden jars joined so as to give one single and united electrical discharge.

**Battery, Constant or Circuit-Closed.** One which, when the circuit is closed, does not polarize very much.

**Battery, Dynamo.** Two or more dynamos properly connected.

**Battery, Gas.** One in which gases constitute the voltaic elements.

**Battery, Magnetic.** Several magnets connected.

(215)

**Battery, Plunge.** One in which the plates may be removed when not in use.

**Battery, Primary.** Several primary cells acting as one.

**Battery, Storage.** Several storage cells acting as one.

**Binding Posts.** Clamps for connecting the conducting wires with the electrical apparatus.

**B. W. G.** These initials stand for Birmingham Wire Gauge, the gauge used in England.

**Board, Switch.** A board so arranged with switches that the circuits may be closed, opened, or interchanged.

**Bobbin.** An insulated coil of wire for an electro-magnet.

**Box, Resistance.** A box containing a number of coils of wire whose resistance is known. Used in measuring resistance in circuits.

**Break.** "To break" is to open the circuit and thus stop the flow of electricity; "to break" is the opposite of "to make."

**Breaker, Circuit.** See Circuit Breaker.

**Bridge, Wheatstone.** Sometimes called an Electric Balance. An apparatus used in measuring resistance.

**B. and S.** B. and S. are the initials of Brown and Sharp, the American wire gauge.

**Brush, Dynamo.** Strips of metal which take off the current from the dynamo.

**Brush Lead.** Moving the brushes forward to prevent sparking.

**Buckling.** An irregular surface on the plates of storage cells caused by a too rapid discharge of current.

**Button, Push.** A circuit closer.

**Calibrate.** To determine the relative value of the scale of a galvanometer.

**Candle-Power.** Usually expressed as C. P. The measure of the intensity of light emitted from any luminous body, expressed in units each of which is equal to the light produced by one standard candle.

**C. P.** Abbreviation for candle-power.

**Candle, Standard.** A candle of definite composition which, with a given composition in a given time, will produce a light of a fixed and definite brightness.

**Carbon.** A non-metal used in forming a cell; also used in forming the light in an arc lamp.

**Catalysis.** A word introduced by Remak as a convenient term to designate a number of complex physical effects of the electric current. Under this term may be included cataphoresis, osmosis, electrolysis, the effect of the current on the circulation of the lymph and the blood, and the trophic influences of the current on the nerves.

**Cataphoresis.** The process of introducing medicaments into the body by the aid of electricity. It is sometimes termed electric osmosis. The name cataphoresis is derived from the fact that the liquid is carried down (*cata*, down; *pherein*, to bear) with the current, *i.e.*, more liquid passes by diffusion through the partition in the direction of the current than in the opposite direction. The process may be shown by using a weak solution of starch and a weak solution of iodine separated by a porous partition. The current, on passing from the iodine to the starch, will carry some of the former with it, thus coloring the starch by chemical reaction with the iodine.

**Catelectrotonus.** A term used to express that state of increased irritability of a nerve when the cathode, or negative pole, is placed near the nerve.

**Cathode.** The negative pole; the way by which electricity *leaves* a body.

**Cation.** The ion which collects at the cathode, or negative pole. The cation is the opposite of anion, *q. v.*

**Cautery.** The electric cautery, or, as it is often called, the galvano-cautery, is usually a platinum wire or blade heated by the aid of electricity and used to burn or cauterize the tissues of the human body.

**Cell.** The jar holding the elements and the exciting fluid necessary to produce electricity.

**C. G. S. Units.** Centimeter-gramme-second units which have been universally adopted by electricians. C. stands for Centimeter, the unit of length, which is the one-hundredth part of a meter and is equal to 0.3937, or about  $\frac{3}{8}$  of an English inch. G. stands for Gramme, the unit of weight, which is equal to 15.434 grains. S. stands for Second, the unit of time. Thus we speak of the centimeter-gramme-second system, or the C. G. S. system.

**Circuit.** The path traversed by the current.

**Circuit Breaker.** An apparatus for interrupting or breaking the circuit, so that the current is unable to flow.

**Clamps.** See Binding Posts.

**Coil, Induction.** See Induction Coil.

**Collecting Plate.** The element from which the positive current comes is usually spoken of as the collecting plate, because of the fact that the hydrogen collects about it.

**Condenser.** An apparatus for accumulating electricity on a small surface.

**Conductor.** A substance which will readily permit the passage of an electric current. Conductor is the opposite of Insulator.

**Conductors.** The electrodes and cords when joined to the battery.



**Contact Breaker.** A device causing an electric current to make and break its own circuit automatically.

**Contact, Metallic.** A contact of a metallic conductor produced by its coming into firm connection with another metallic conductor.

**Contractions, Closing.** Those produced at the moment of *closing* or *making* the circuit.

**Contractions, Opening.** Those produced at the moment of *opening* or *breaking* the circuit.

**Converter.** The inverted transformer or induction coil used on alternating current systems.

**Core.** A bundle of soft iron *wires* used as a magnet in the centre of a coil; it may also be a *bar* of soft iron, instead of wires.

**Coulomb.** The unit of quantity.

**Couple, Astatic.** Two magnets of equal strength suspended one over the other in the same vertical plane, with poles opposed so as completely to neutralize each other.

**Couple, Thermo-Electric.** Two dissimilar metals which, if joined at their ends only and connected to form a complete circuit, will produce an electric current when heated at the point of junction.

**Couple, Voltaic or Galvanic.** Two dissimilar metals in an electrolyte which are capable of producing an electric current.

**Cross, Electric.** Accidental contact between two or more conductors.

**Current, Alternate.** A current in which the direction is changed at regular intervals.

**Current, Ascending.** A current applied by placing the anode, or positive electrode, upon the periphery of a nerve, and the cathode, or negative electrode, at the nerve centre.

**Current Breaker.** A device for opening and closing the circuit.

**Current, Centrifugal.** A descending current.

**Current, Centripetal.** An ascending current.

**Current, Constant.** A current from a constant battery.

**Current Density.** The current which passes in any part of a circuit as compared with the area of cross-section of that part of the circuit.

**Current, Descending.** Antithesis of the ascending current in that the cathode is on the periphery and the anode at the centre.

**Current, Direct.** A non-alternating current.

**Current, Electric.** The quantity of electricity which passes per second through any conductor or circuit.

**Current, Faradic.** See Faradic Current.

**Current, Galvanic.** The direct current.

**Current, Induced.** The current produced in a conductor by cutting magnetic lines of force. When a charged body is brought near another, but not in contact with it, the latter becomes electrified or possesses an induced charge. The faradic current is often spoken of as the induced current.

**Current Reversor.** A pole changer.

**Current Selector.** A device for altering the strength of a current.

**Current Strength.** The product obtained by dividing the electro-motive force by the resistance. According to Ohm's law, the strength for a constant current is:

$$C. \text{ (current)} = \frac{E. \text{ (Electro-motive force)}}{R. \text{ (Resistance)}} \text{ or } C. = \frac{E.}{R.}$$

**Current, Transforming a.** Changing the electro-motive force of a current by its passage through a converter or transformer.

**Currents, Earth.** Electric currents flowing through the earth, caused by a difference of potential at different points.

**Currents, Eddy.** Useless currents produced in metallic masses such as pole pieces, armatures, and field magnet cores of dynamos and motors. They are caused either by motions through magnetic fields or by variations in the strength of the electric currents flowing near them.

**Currents, Oscillatory.** These currents flow periodically in opposite directions but not necessarily for the same length of time. The maximum values of successive waves change in a regular order. Oscillatory are alternating currents, while pulsatory are direct currents.

**Currents, Pulsatory.** These currents vary their potential in repeated cycles. They are direct currents.

**Currents, Simple Periodic.** Alternating currents. A current of such a nature that the continuous variation of the flow past any cross-section of the conductor, or the variation of its electro-motive force can be expressed by a simple periodic curve, such as a sine curve.

**Currents, Undulatory.** Currents, the duration and strength of whose flow gradually change.

**Cycle.** A period of time within which the same phenomena regularly recur in the same order.

**Damper.** A retarding device. A metallic cylinder surrounding the core of an induction coil for the purpose of varying the intensity of the induced currents.

**Damper, Arc-Lamp.** The dash-pot or other device offering resistance to quick motion.

**Daniell Cell.** See description of cells under Galvanism, in the general text.

**Dead-Beat.** This applies to the motion of a galvanometer needle that moves sharply over the scale from point to point, and comes quickly to rest, instead of swinging to and fro.

**Declination.** The dip of the needle.

**Demagnetization.** A process through which a body may be deprived of its magnetism.

**Density, Electric.** The quantity of free electricity on any unit of surface area.

**Density, Magnetic.** The magnetic strength as measured by the number of lines of force that pass through a unit of cross-section of the magnet.

**Depolarization.** Depriving a voltaic cell of its polarization. Removing the bubbles of gas which collect on the negative plate.

**Derivation Wire.** A wire connecting two points in a closed circuit.

**Derived Current.** A current drawn off by a derivation wire from the main current.

**Detector, Ground.** A device used in incandescent lighting. It is placed in the central station, and shows by the candle-power of the lamp the approximate location of a "ground" on the system.

**Diamagnetic.** Having the property of being repelled from both poles of a magnet, and tending to take a position with the larger axis across the line of magnetic force.

**Diamagnetic Bodies.** Bodies not susceptible of being magnetized.

**Dielectric.** A substance which permits induction to take place through its mass. A non-conductor. The glass of a Leyden jar is the dielectric.

**Diffusion of Current.** The power of a galvanic current to extend its influence in all directions, that power never being limited to the two electrodes.

**Dimmer.** An adjustable resistance used in electric lighting, such as theatre lighting, to regulate the brightness of the lamps.

**Dipping, Electro-Metallurgical.** A process for obtaining an electro-metallurgical deposit on a metallic surface by dipping it into a metallic salt solution.

**Disc, or Disk.** The thin sheets forming the core of a laminated armature.

**Disc, Arago's.** A non-magnetic metal disc, as of copper, which, when rotated rapidly under a freely supported magnetic needle, will cause the needle to be deflected or to rotate.

**Disc, Faraday's.** A non-magnetic metal disc fixed on an axis parallel to the direction of the magnetic field in which it is to move.

**Discharge.** The phenomenon which occurs in the equalization of the difference of potential between the terminals of a source of electricity when connected by a conductor.

**Discharge, Brush.** The faintly luminous brush-shaped discharge which occurs at the negative electrode of a static machine.

**Discharge, Disruptive.** A violent discharge which takes place across an intervening non-conductor.

**Discharge, Oscillating.** Successive discharges and recharges which occur on the disruptive discharge of a conductor.

**Discharger, Universal.** An apparatus for sending the discharge of a condenser in any desired direction.

**Distance, Explosive or Sparking.** The distance at which electrical sparks will pass through an intervening air space.

**Drop, Annunciator.** A movable shutter or signal operated by an electro-magnet. When it drops, it indicates the closing of the circuit indicated.

**Dynamic Electricity.** Electricity in motion. It is the opposite of static, which is electricity at rest.

**Dynamo.** A mechanically driven machine which furnishes electricity in either a direct or alternating current, or in both.

**Dynamo, Composite Field.** A dynamo where the field coils are in series and separately excited.

**Dynamometer.** A form of galvanometer. An apparatus for measuring the power given out or consumed by a machine.

**Dyne.** The unit of force.

**Ebonite.** A hard black substance composed of india rubber and sulphur, and used as an insulator. It possesses high powers of specific inductive capacity.

**Effect, Joule.** The heating effect produced by the passage of an electric current through a conductor.

**Effect, Peltier.** The heating effect produced by the passage of an electric current across a thermo-electric junction.

**Effect, Thermo-Electric.** The production of an electro-motive force at a thermo-electric junction by a difference of temperature.

**Effect, Voltaic.** A difference of potential at the point of contact of two dissimilar metals.

**Efficiency, Electric.** The useful electrical energy from any source divided by the total consumed energy.

**Efficiency, Real, of a Storage Battery.** The ratio of the number of watt-hours taken out of a storage battery, to the number of watt-hours put into the battery in charging it.

**Electric Aura.** A current of electrified air.

**Electric Brush.** An electrode in the form of a wire brush.

**Electric Force.** This is the force with which electricity tends to move matter, and is not to be confounded with E. M. F.

**Electricity.** The name given to that which causes all electrical phenomena. Electricity is a form of energy just as heat is. Electricity is always the same, by whatever means produced; there is but *one kind* of electricity.

**Electricity, Animal.** Free electricity in the body.

**Electricity, Atmospheric.** The free electricity in the air, which is generally positively charged, while the earth is negative. The atmospheric electricity is subject to perpetual changes and, occasionally, is negative.

**Electricity, Dynamic.** Electricity *in motion*.

**Electricity, Faradic.** See Faradic Current.

**Electricity, Galvanic.** See Galvanic Current.

**Electricity, Static.** Electricity *at rest*, nevertheless, while static electricity is described as electricity *at rest* it is really electricity in a state of tension.

**Electricity, Magneto-.** Electricity produced by magneto-electrical induction, as by a magneto machine. It is the same as every other current form.

**Electricity, Pyro-.** Electricity manifested in certain substances when they are unequally heated or cooled. Tourmaline, which is a mineral consisting of aluminum-boron silicate and occurs in elongated crystals, shows it strongly.

**Electricity, Thermo-.** Electricity produced by a difference of temperature at a junction of two metals.

**Electricity, Voltaic.** Electrical manifestations produced by the voltaic pile, cell, or battery. The current from an ordinary battery.

**Electric Moxa.** A burn on the skin from electricity.

**Electrizers.** Metal discs of copper and zinc, or of silver and zinc, applied to the surface of the body and connected with copper wire; they excite, with the perspiration of the body, a feeble galvanic current.

**Electrocution.** Capital punishment by means of electricity.

**Electrode.** Either of the terminals of a source of electricity, such as the poles of a battery; the instruments fastened to the conducting cords that are used in applying electricity.

**Electrode, Positive.** The electrode connected with the positive pole of a source of electricity.

**Electrode, Negative.** The electrode connected with the negative pole of a source of electricity.

**Electrode, Sponge.** An electrode to which is fastened a sponge that is moistened. The sponge electrode is used very much in electro-therapeutics.

**Electro-Diagnosis.** The diagnosticating of disease by means of electricity.

**Electrolysis.** Chemical decomposition caused by means of an electric current.

**Electrolyte.** The fluid contained in a galvanic cell.

**Electrolytic.** Relating to chemical decomposition produced by electricity.

**Electro-Magnet.** A mass of soft iron surrounded by a coil of wire.

**Electro-Magnetism.** The current from a magneto-electric machine.

**Electrometer.** An apparatus for measuring differences of potential.

**E. M. F.** Electro-motive-force; sometimes written simply E. It is the force that sets electricity in motion, or the difference of potential between two points, the transfer always taking place from the higher to the lower, *i.e.*, from positive to negative.

**Electrophorus.** An apparatus for the production of electricity by electro-static induction.

**Electro-Puncture.** The application of electricity by means of needles thrust into the tissues.

**Electroscope.** An instrument for detecting whether a body is electrified and whether the electrification is positive or negative.

**Electro-Tonic.** The name given to the changing state of the conducting wires while the current is forming or ceasing.

**Electrotonus.** The altered activity in a motor-nerve when subject to the action of electricity. (a) **Anelectrotonus.** The condition of *decreased* irritability which exists in that portion of a nerve nearest the positive pole after a current of electricity has been carried through it for some time. (b) **Catelectrotonus.** The state of *increased* irritability of a nerve near the *cathode*.

**Elements.** The metals, or carbon and metals, immersed in the battery fluid.

**Energy, Electric.** The power which electricity possesses of doing work. It is generally measured in rate of doing electric work. The current in ampères multiplied by the difference of potential in volts, divided by 746, equals the rate of doing work in horse-power. 746 volt-ampères, or watts,—for a watt equals one volt times one ampère—equals one horse-power.

**Energy, Electric, Transmission of.** The transmission of mechanical energy between two distinct points connected by an electric conductor, by converting the mechanical energy into electrical energy at one point, sending the current so produced through the conductor and reconvertng the electrical into mechanical energy at the other point.

**Energy, Kinetic.** Energy which is due to motion, in contradistinction to potential.

**Energy, Potential or Static.** Energy possessing the power of doing work, but not actually performing such work. Stored energy, or the power of doing work by a body at rest.

**Erg.** The unit of work.

**Essential Resistance.** The *internal* resistance within a battery cell.

**Explorer, Electric.** An apparatus used for the purpose of locating metallic substances in the body, often used as a bullet finder.

**Farad.** The unit of electrical capacity. The micro-farad—one-millionth of a farad—is the unit usually employed.

**Faradic Current.** The induced, interrupted or extra current. The current generated in a coil of wire by induction.

**Faradic Induction.** The excitement, by a current of electricity passing through a wire, of a wave of electricity in a second wire placed near and parallel with it, at the instant of opening and closing the circuit.

**Faradism.** The application of the faradic current to the treatment of disease.

**Faradization.** The application of the faradic current to a diseased part.

**Fault.** A failure in the proper working of a circuit.

**Fault, Localization of.** Determining the position of a fault by calculations based on the fall in potential at different points of the line, or by loss of charge.

**Field, Electro-Magnetic.** The space traversed by the lines of force around a magnet; the space around a conductor carrying a current which is pervaded by magnetic forces.

**Field, Electro-Static.** The region of electro-static influence surrounding a charged body.

**Field, Intensity of a.** The strength of a field as measured by the number of lines of force that pass through it per unit of cross section.

**Field, Magnetic.** The region of magnetic influence surrounding the poles of a magnet.

**Field, Magnetic Alternating.** The magnetic field produced by an alternating current.

**Filament.** In an incandescent lamp, the thread of wire or carbon which becomes luminous under the heating effect of an electric current passing through it.

**Finder, Wire.** A galvanometer used to locate the corresponding ends of different wires in a bunched cable.

**Fluorescence.** The property possessed by certain solids and liquids of becoming luminous under certain conditions. Under the

influence of X-rays, crystals of calcium tungstate become fluorescent.

**Flux, Magnetic.** The total number of lines in any field. The number of lines of force which pass through a magnetic field.

**Force, Coercive.** The power of resisting magnetization or demagnetization.

**Force, Electro-Motive.** The force starting, or tending to start, electricity in motion.

**Force, Electro-Motive, Absolute Unit of.** The one-hundred millionth part of a volt.

**Force, Counter Electro-Motive.** An opposing electro-motive force which tends to cause a current in the direction *opposite* to that actually produced by the source of electricity. In an electric motor, an electro-motive force contrary to that produced by the current which drives the motor and proportioned to the velocity attained by the motor.

**Force, Magnetic.** The force which causes the attractions or repulsions of magnetic poles.

**Franklinism.** Static electricity employed in medicine.

**Frictional Electricity.** Electricity produced by friction; also known as Static or Franklinic.

**Fulguration.** A term used to describe the removal of warts, etc., by means of the high frequency currents applied by a special electrode.

**Fuse, Safety.** A strip, bar, plate, or wire of lead or some fusible alloy, which automatically breaks the circuit, by fusing, on the passage of a certain amount of current such as would endanger the safety of other parts of the circuit.

**Fustigation, Electric.** The application of electricity by means of a metallic brush.

**Galvanic Action.** The corroding of plates and stays, supposed to be caused by currents of electricity being generated in a cell or jar. Termed, also, Voltaic Action.

**Galvanic Belt.** A series of small cells so arranged that there is produced a continuous application of galvanism.

**Galvanic Chain.** A chain, the links of which are composed alternately of zinc and copper. This chain is worn around the body next to the skin. The moisture of the body may possibly at infrequent intervals generate a mild galvanic current. At best, however, only the so-called "psychic influence" may be expected of it since the strength of current is practically nil! Its "curative" properties are purely imaginary.

**Galvanic Circle.** If we speak of a single circle, we mean one galvanic cell in action, *i.e.*, connected outside the electrolyte, or fluid; a compound circle would mean two or more single circles.



**Galvanic Contractility.** The contraction of muscles seen when we apply the galvanic current.

**Galvanic Current.** The current from a galvanic cell.

**Galvanic Discs.** Discs of zinc and copper arranged alternately so that the moisture of the human body produces a galvanic current.

**Galvanic Elements.** Zinc and copper, or zinc and carbon, used in a galvanic cell.

**Galvanism.** A term employed to express effects produced by galvanic or voltaic electricity; the form of electricity which is generated by chemical action; called also Voltaism.

**Galvano-Cautery.** A wire or plate of platinum used to cauterize the tissues by means of a galvanic current.

**Galvanometer.** An instrument used to detect and measure the electric current. The strength of current is calculated from the deflection of the needle.

**Galvanometer, Astatic.** One having two magnetic needles so arranged that the earth's magnetism has little or no effect on them.

**Galvanometer, Ballistic.** A form of galvanometer used to measure the strength of a current that lasts but for a moment. The current caused by the discharge from a condenser would be measured by it.

**Galvanometer, Dead-Beat.** In this form of galvanometer the needle comes to rest quickly, instead of swinging to and fro.

**Galvanometer, Marine.** A form of galvanometer used on ships where the motion of magnetized masses of iron would seriously disturb the needles of ordinary galvanometers.

**Galvanoscope.** An instrument used to show the direction of a galvanic current.

**Gap, Spark.** The space between the prime conductors, as in a static machine.

**General Electrization.** This means the application of an electric current to all parts of the human body. We may employ any of the currents—Galvanic, Faradic, Sinusoidal, etc.

**Generator, Pyro-Magnetic.** An apparatus that will produce electricity when heat is applied.

**Governor, Current.** A current regulator arranged to maintain a constant current-strength in a circuit.

**Graphite.** Lead pencils are made of graphite, which is a soft carbon; this was formerly used extensively on rheostats, but is *not* now used in the better rheostats, which obtain the resistance through the heating of wire.

**Gravity Batteries.** These are galvanic batteries containing two fluids which are separated by a difference in density; the elements are placed horizontally instead of perpendicularly.

**Ground.** The contact of an electric conductor and the earth.

**Heat.** An invisible radiation. Light, heat, and electricity are now thought to be different rates of motion and length of similar waves of energy.

**Henry.** The name given to the practical unit of self-induction.

**Hertzian Waves.** They were discovered by Dr. Hertz. They are a form of energy-waves travelling 186,400 miles per second.

**Horse-Power (written H. P.).** The commercial unit for power of doing work. This power consists of doing work equivalent to raising 33,000 pounds one foot per minute. An electrical horse-power equals 746 watts.

**Hydro-Electrization.** Application of electricity to the human body by using water as the electrode, as in a bath.

**Hydrostat.** Used to prevent the spilling of fluid from wet battery cells.

**Incandescence.** The degree of white light given out by a body when intensely heated, usually by the electric current.

**Inclination, Angle of.** The angle of magnetic dip.

**Inclination, Magnetic.** The deviation of a magnetic needle from a horizontal position.

**Induced Charge.** When a charged body is brought near to another, but not in actual contact, the latter will possess an induced charge.

**Induction.** When an object is brought near to, but not in actual contact with, a circuit through which a current is flowing, we find that the object becomes electrified. This process is known as induction.

**Induction Coil.** The coarse wire coil through which the primary current passes.

**Induction, Electro-Static.** The charge produced when a conductor enters an electro-static field.

**Induction, Self.** The induction of a current flowing in each portion of a circuit on neighboring convolutions of the same coil. When the current is started, stopped, or varied in any manner, the induction occurs.

**Initial Charge.** A charge excited on glass or rubber and conveyed to the plates of a static machine by contact.

**Insulation.** Non-conducting material, placed over or around a conductor, to prevent the escape of electricity.

**Insulator.** Any substance which hinders the passage of electricity. It is the opposite of a conductor. Insulators may be of glass, dry wood, oil, fibre, or hard rubber.

**Intensity.** The energy with which electricity acts.

**Interrupted Current.** A current that is alternately closed and opened.

**Inverse Current.** The ascending current.

**Ions.** The product of decomposition in electrolysis; the ion which collects at the positive pole is called the *Anion*, while that at the negative pole is the *Cation*, *quod vide*. Faraday called them "ions" or "travelers."

**Jar, Leyden.** A static condenser in the form of a glass jar. There must be both an outside and an inside coating of metal which reach to within three inches of the top. Through the cover of the jar there extends a brass rod with a knob at the upper end and a chain at the lower. The chain makes contact with the lower portion of the inner coating.

**Joule.** The practical unit of work in the C. G. S. system.

**K.** A symbol for electro-static capacity.

**K. W.** The initials of Kilowatt, which means one thousand watts.

**Kathion.** Another spelling of Cation.

**Kathode.** Another spelling of Cathode.

**Key, Discharge and Charge.** When we wish to pass the discharge from a condenser through a galvanometer for measurement, we use this form of key.

**Key, Telegraph.** A simple switch by means of which the hand is enabled to open and close the circuit of a telegraph line to produce the Morse alphabet.

**Key, Plug.** A metal plug inserted between two metal plates, to bring them into circuit.

**L.** The symbol for the co-efficient of induction.

**Labile Current.** The current is obtained by moving one or both electrodes over the surface to be treated. It is the opposite of stabile.

**Lamp, Arc.** The electric lamp which uses a pair of carbon sticks to produce light.

**Lamp, Inclosed Arc.** In this electric lamp a small glass globe encloses the ends of the carbons.

**Lamp, Incandescent.** A form of electric lamp using a glass globe from which nearly all the air has been exhausted. Inside the globe we find a filament of carbon, platinum, or tungsten, the heating of which to incandescence produces the light. The tungsten is the latest and best form of incandescent lamp, its only drawback being that the tungsten filament is very fragile and so easily broken. A curious feature of the tungsten filament is that, when heated, the lamp may be handled with less danger of breaking the filament.

**Latent Electricity.** Passive electricity.

**Leads.** The conductors used to distribute electricity.

**Leakage, Electric.** The loss of current due to poor insulation, or to induction.

**Leakage, Magnetic.** The dissipated lines of magnetic force which form what is known as a stray field.

**Light, Maxwell's Theory of.** This theory is that light and magnetism are produced by motion of ether waves. It is supposed that light is produced by oscillations, and electricity and magnetism by rotary motion.

**Lines of Magnetic Force.** The curved lines through which the force emanating from a magnet acts.

**Liquid, Electropon.** A liquid for a galvanic battery. The composition of this fluid is given, in the body of the text, under Galvanism.

**Lodestone.** Iron ore naturally magnetized.

**Loop, Drip.** A loop of electric wires just where they enter a building, and designed to prevent water following along the wires into the building.

**Loop, Electric.** A loop used to bridge a break in a main circuit.

**Magnet.** A bar of steel or iron possessing the quality, peculiar to the lodestone, of attracting or repelling other bodies.

**Magnet, Armature of a.** A bar of soft iron placed across the ends of a horseshoe-shaped magnet to prevent dissipation of the magnetism.

**Magnet, Electro-.** A body which is a magnet only while a current of electricity is being passed through it. See under Faradism in the general text.

**Magnet, Permanent.** Usually a piece of hardened steel which retains its magnetism for a long time.

**Magnetic Axis.** The line which joins the poles of a magnet.

**Magnetic Field.** The space around a magnet and included within its lines of force.

**Magnetism, Ampère's Theory of.** He assumed that the phenomena of magnetism are due to the presence of electric currents in the atoms of substances that are capable of being magnetized.

**Magneto-Electricity.** Electricity set free by the action of a magnet.

**Magnetometer.** A reflecting galvanometer, used to measure the intensity of the earth's field.

**Metallurgy, Electro-.** The science of the electrical treatment of metals.

**Micro-Farad.** The *practical* unit of capacity.

**Micrometer, Arc.** A micrometer used to measure the distance between the electrodes.

**Microphone.** A telephone instrument used to render slight sounds audible.

**Motor, Electric.** A machine which changes electrical power into mechanical power; it may be a direct current or an alternating current motor. The direct is more largely used.

**Motor-Points.** The points on the surface of the human body where the motor nerves may best be affected by electricity. The point on a muscle where a contraction may be produced by the minimum amount of electricity.

**Moxa.** See Electric Moxa.

**Multiple, or Multiple Arc.** We say cells are connected in multiple—or parallel—when all the positive poles are connected to form one positive pole, and all the negative poles to form one negative pole. This is the opposite of being connected *in series*.

**Negative.** The difference between negative *plate* and negative *pole* is fully explained in the chapter under Galvanism, in the general text.

**Negative Pole.** See Cathode.

**Ohm.** The unit of resistance.

**Ohm's Law.**  $\text{Ampères} = \frac{\text{Volts}}{\text{Resistance}} = A. = \frac{V.}{R.}$  Or it may be

expressed:  $\text{Current} = \frac{\text{E. M. F.}}{\text{Resistance}} = C. = \frac{E.}{R.}$

**Opening Contractions.** Muscular contractions produced on opening or breaking the circuit.

**Oscillation, Electric.** Henry discovered that the seemingly instantaneous discharge of a Leyden jar consists in reality in a series of oscillations at the rate of one million per *second*.

**Periodicity.** The rate at which the alternations of an electric current are made.

**Pile, Voltaic.** This consists of alternate discs of copper and zinc, or silver and zinc, separated by paper moistened with a dilute acid solution.

**Plug, Safety.** A metal plug which readily fuses when too large an amount of current passes.

**Polarity of Nerves.** See Anelectrotonus and Catelectrotonus. The condition is called *polarity of nerves*.

**Polarization.** The deposit of bubbles of hydrogen upon the carbon element in a galvanic cell. See Polarization, under chapter on Galvanism, in the general text.

**Polar Method.** In this method we place the *pole whose effect* we wish over the part to be treated; we place the other pole on some indifferent point, such as the sternum.

**Pole Changer.** A device for changing the polarity without removing the electrodes from the body.

**Positive.** See Anode.

**Post, Binding.** See under Binding Post.

**Potential.** A term, used in electricity, which is analogous to

temperature in heat. It means the power of an electric source to do work.

**Primary Coil.** The layers of coarse wire which form the inner coil.

**Primary Current.** The current from the primary coil.

**Regulator, Hand.** A resistance box operated by hand.

**Relay.** An electro-magnetic switch.

**Relay, Polarized.** A relay for telegraphic use.

**Resistance.** The opposition offered to the passage of electricity.

**Resistance, Unit of.** The ohm.

**Reverser, Current.** Same as pole changer, *quod vide*.

**Rheometer.** A galvanometer.

**Rheomotor.** An apparatus for originating an electric current, not to be confused with *rheometer*.

**Rheophore.** The conducting cord.

**Rheoscope.** A galvanoscope, *quod vide*.

**Rheostat.** A device for introducing resistance into a circuit. Some are made of graphite and others of wire, the wire rheostat being the better.

**Rheotome.** An automatic current breaker.

**Rotary Converter.** An apparatus for changing a direct to an alternating current.

**Ruhmkorff Coil.** The induction coil invented by Ruhmkorff.

**Secondary Battery.** A storage battery.

**Secondary Coil.** The coil of fine wire wound in many layers around the primary coil, in a faradic battery.

**Secondary Current.** The faradic current obtained from the secondary coil.

**Sensibility, Electro-Muscular.** The sensation produced on a muscle contracted by electricity.

**Separator.** An insulating substance placed between storage battery plates to prevent short-circuiting.

**Series.** The opposite of Multiple or Parallel, *quod vide*.

In connecting in *series*, we connect the *zinc* to *carbon*; in connecting in *multiple*, we connect *zinc* to *zinc*.

**Series, Thermo-Electric.** Metals so arranged, with reference to their thermo-electric properties, that each is electro-positive to any other following it.

**Shellac.** The resinous substance largely used as an insulator.

**Shield.** The tube used to separate the primary and secondary coils of a faradic battery.

**Shock.** A sudden discharge of electricity. The sensation experienced in the human body, by making or breaking the circuit, is also spoken of as a shock.

**Short Circuit.** A circuit completed before reaching the conductors or electrodes.

**Shunt.** An additional path established by connecting one conductor to another in such a way as to deprive the first of a part of its current. When two conductors are connected in multiple with a source of current-supply, each is said to be in *shunt* of the other. It is a tap.

**Solenoid.** A cylindrical coil of wire having a soft iron core.

**Sounder.** A resonator used in telegraphy, the Morse sounder being the one in general use.

**Source, Electric.** A device, like a battery or a dynamo, that will produce an electro-motive force.

**Stabile Current.** Produced when both electrodes are held stationary on the body. The opposite of *labile*, in which one electrode is kept in motion.

**Static Electricity.** Electricity under tension. Franklinic or frictional.

**Sulphating.** In storage batteries an inert sulphate of lead forms on the plates and so produces a loss of electricity; this is known as sulphating.

**Supply, Unit of Electric.** Known also as the Board of Trade Unit. It means 1000 watt-hours and is the unit used in charging for electricity supplied for lighting and heating. Ten ampères of a 100-volt current running for one hour would equal 1000 watt-hours — 10 a. times 100 v. = 1000 watts times 1 hr. = 1000 watt-hours.

**Switch.** A part of the battery accessories which is attached to the base of the instrument; switches are used as current reversers and current selectors.

**Switch, Knife.** A knife-edge switch by means of which a circuit may be opened or closed by contact between parallel contact plates. Used chiefly for circuits carrying heavy currents.

**Synchronism.** The simultaneous occurrence of vibrations, pulsations, and current reversals.

**System, Three-Wire.** A system, explained elsewhere in this book, invented by Edison. Two dynamos were formerly used; but, by a new method, the three-wire system is now operated by means of one dynamo.

**Tape, Insulating.** Some flexible material impregnated with rubber, arranged in ribbon form and used to cover wires and joints to insulate them.

**Tension.** The tendency of electricity to overcome resistance.

**Terminal.** The point where a current of electricity enters or leaves a source of electricity.

**Tetanzation.** The tetanic condition produced in a nerve or a muscle by electricity.

**Thermo-Electricity.** Two metals are soldered together so as to form a closed circuit. Unequal heating of one junction will produce thermo-electricity.

**Thermostat.** An instrument responsive to changes in temperature, used for controlling an electric current.

**Time Cut-Out, Automatic.** A device used with a storage battery to throw it in circuit or cut it out, at certain times.

**To-and-Fro Current.** The interrupted, or faradic current.

**Torque.** The mechanical twisting or rotary force which acts upon the armature of a dynamo or motor.

**Transformer.** A kind of induction coil. An apparatus used to *raise* or *lower* the voltage of an alternating electric current before distributing the current for lighting, and other uses.

**Transformer, Step-Down.** A transformer for converting a *small* current of *high voltage* into a *large* current of *low voltage*. The opposite of the *Step-Up Transformer*.

**Transformer, Step-Up.** A transformer for converting a *large* current of *low voltage* to a *small* current of *high voltage*.

**Transformer, Welding.** A kind of *step-down* transformer for converting a *light* current of *high* pressure into a *heavy* current of *low* pressure, suitable for electric welding.

**Trembler.** A vibrator.

**Two-Fluid Cell.** A cell containing two fluids, one for each element.

**Turn, Ampère.** One single turn in a coil of wire through which one ampère of current passes. We use this term to denote the electrical power which is being expended in producing magnetism. The "ampère turns" of an electro-magnet are the product of the number of turns of wire times the number of ampères flowing through the coil.

**Uninterrupted Current.** The galvanic, or direct current.

**Unit of Current** = The ampère.

**Unit of E.-M. Force** = The volt.

**Units, Practical.** The volt, ampère, ohm, coulomb and watt.

**Unit of Resistance** = The ohm.

**Vacuum.** A space from which the air has been partially exhausted.

**Vacuum Electrodes.** Hollow glass electrodes of different shapes from which the air has been more or less exhausted before the end of the electrode is sealed.

**Vitreous Electricity.** Produced by the friction of glass.

**Volt.** The unit of electro-motive force.

**Voltage.** The electro-motive force in a circuit.

**Voltaic Alternatives.** Term used to indicate a method in which a pole changer not only breaks the circuit but also changes the direction of the current at every break.



**Voltmeter.** An apparatus for measuring the strength of a galvanic current by its electrolytic action on some fluid.

**Volt-Ammeter.** A watt-meter. It is an instrument for measuring the energy of an electric current directly in watts.

**Voltmeter.** An instrument showing on a scale the number of volts.

**Watt.** The unit of electric power or activity. The watt is found by multiplying the number of ampères by the number of volts, *i.e.*, 10 ampères  $\times$  100 volts = 1000 watts. One watt equals  $\frac{1}{746}$  H. P.

**Wattmeter.** An instrument for measuring the work done.

**Welding, Electric.** Welding of metals by means of electricity.

**Wire, Dead.** A wire over which no current is passing at the time.

**Wire, Fuse.** A safety fuse wire placed in a safety catch, as a protection against an excess of current.

**Wire-Gauge.** A gauge with notches on its edge, or circumference, which are standards for the thickness of wire, sheet metal, etc. See B. W. G. and B. and S. in glossary.

**Wires, Leading-In.** The wires which conduct the current in and out of an incandescent lamp.

**Wire, Live.** A wire over which a current of electricity is passing.

**Wire, Negative.** The wire connected with the negative pole of a battery or dynamo.

**Wires, Pilot.** Wires leading directly to the central station, from distant points of a circuit, in incandescent lighting systems. By means of these wires the voltage at such points may be watched.

**Wire, Positive.** The wire connected with the positive pole.

**Wire, Return.** The wire by which a current returns to its source after completing the circuit.

**Wire, Span.** The wire used to hold up the wire for the trolley car.

**Wire, Trolley.** The overhead wire from which electricity is taken to operate the motors of trolley cars.

**Zinc, Amalgamation of.** Zinc covered with a thin coating of mercury.

## INDEX.

- Abscess, 211  
  of brain, 158  
Acne, 135, 211  
Actino-therapy, 183  
Adenitis, 211  
Adhesions, pelvic, 211  
After-pains, 211  
Alopecia, 211  
  areata, 211  
Amalgamation, 19  
  electrolyte, 18  
    directions for preparing solution, 19  
Amenorrhea, 211  
Ampère, 10, 11  
Anal fissure, 135  
Analgesia, 211  
Anemia, 211  
  cerebral, 211  
Anesthesia, 99, 158  
Aneurysm, 211  
Angina pectoris, 211  
Angioma, 211  
Ankylosis, 211  
Aphonia, hysterical, 211  
Appendix, 191  
Arteriosclerosis, 211  
Arthritis, acute, 211  
  chronic, 211  
  deformans, 135  
  rheumatoid, 135  
Asphyxia, 211  
Asthma, 135  
Atrophy of optic nerve, 211
- Bachelet, 147  
Bath, sinusoidal electric, 116  
  static electric, 52  
Baths, hydro-electric, 145  
  di-polar, 145  
  faradic, 146  
    effects of, 146  
  galvanic, 146
- Baths, galvanic, effects of, 146  
  mono-polar, 145  
  temperature of water in, 146  
Batteries, 16, 19  
  portable, 16  
  stationary, 16  
Battery arranged in series, diagram of, 23  
  formation of, 23  
Blue light, 189  
Blunt, 182  
Bordier, 122  
Bottini, 108  
Brewer, 209  
Bridge, Wheatstone, 193  
Bronchitis, 211  
"By-pass," 35
- Callosities, 211  
Cancer, 211  
Capacity, unit of, 13  
Carbuncle, 211  
Carcinoma, 135  
Cataplexy, 211  
Cataphoresis, 97  
  acids, 99  
  aconitine, 100  
  anemic, 102  
  anesthesia by, 99  
  bases, 98  
  carbolic acid, 101  
  chloroform, 100  
  citrate of lithium, 101  
  citric acid, 102  
  cocaine, 100, 102  
  electrodes for, 102  
  helleborine, 101  
  iodide of potassium, 97, 103  
  morphine, 99  
  quinine, 103  
  salicylic ion, 103  
  strychnine, 102  
  summary of uses of, 102

(235)

- Catarrh, nasal, 136  
 Caутery, electric, 104  
   arrangement of cells for, 105  
 Cell, best, for office use, Leclanché,  
   25  
   best kind for portable battery,  
   24  
   chloride of silver, electro-motive  
   force of, 9  
   copper-zinc, electro-motive force  
   of, 9  
   Daniell, electro-motive force of,  
   9  
   Leclanché, electro-motive force  
   of, 9  
   short-circuited, 19, 26  
   zinc-carbon, electro-motive force  
   of, 9  
 Cells, galvanic, kinds of, 14, 16  
   bichromate, 17  
     Grenet, 17  
   chromic acid, 17  
   double fluid, 14, 16  
     Bunsen, 16  
     Daniell, 16  
     Grove, 16  
   dry, 18  
   gravity, 17  
   Law, 17  
   Leclanché, 17  
   porous, 17  
   selenium, 17  
   silver chloride, 17  
   single fluid, 14, 17  
     Smee, 16  
     zinc-carbon, 17  
   table of different kinds of,  
   18  
   voltaic, 18  
     in multiple, 24  
     in parallel, 24  
 Cerebral diseases, 159  
 Chalazion, 212  
 Chancroid, 212  
 Chilblains, 212  
 Chloasma, 212  
 Chlorosis, 137, 212  
 Chorea, 159, 212  
 Cicatrix, 212  
 Circuit, 8  
   arc, multiple, 9  
     parallel, 9  
   broken, 9  
   closed, 9  
   complete, 9  
   definition, 8  
   Circuit, divided, 9  
     external, 9  
     factors, three, in, 9  
       current, 10  
       electro-motive force, 10  
       resistance, 10  
     internal, 9  
     open, 9  
     series, 9  
     shunt, 9  
 Colitis, mucous, 212  
 Conduction, 6  
   resistance, 6  
     insulators, 6  
     non-conductors, 6  
     table of, 6  
 Conductivity of liquids, 32  
 Conjunctivitis, 212  
 Constipation, 137, 212  
 Convalescence, 212  
 Coryza, 212  
 Coulomb, 10, 11  
 Couple, galvanic, 14  
 Cunningham, 193, 194  
 Current, alternating, 26  
   motor, 26  
   rectifier, 27  
   direct, 26  
     generator, 26  
   electric, effects of, 13  
     forms of, 15  
   electricity, 14  
     potential of, 52  
   galvanic, source of, 16  
   street, dangers of, 16  
   strength, 10  
     measuring, 11  
     Ohm's law, 10  
   unit of, ampère, 10, 12  
   unit of quantity consumed,  
     millicoulomb, 12  
   unit of quantity of, coulomb, 11  
   volume, unit of, milliampère, 12  
   within a cell, diagram of direc-  
     tion of, 20  
 Currents, high frequency, 119  
   application of, 129  
   discoverer of, 119  
   diseases and conditions in  
     which, do good, 135  
     acne, 135  
     anal fissure, 135  
     arthritis deformans, 135  
     arthritis, rheumatoid, 135  
     asthma, 135

- Currents, high frequency, diseases  
     and conditions in which,  
     do good, carcinoma, 135  
     catarrh, nasal, 136  
     chlorosis, 137  
     constipation, 137  
     deafness, 137  
     diabetes, 137  
     diagnosis, 137  
     dyspepsia, 137  
     eczema, 138  
     gleet, 138  
     goitre, exophthalmic, 138  
     gout, 138  
     headaches, 138  
     hemorrhoids, 139  
     hysteria, 139  
     indigestion, 139  
     intestinal, 139  
     insomnia, 139  
     laryngitis, chronic, 140  
     leucorrhœa, 140  
     locomotor ataxia, 140  
     lumbago, 140  
     moles, 140  
     neuralgia, 141  
     neurasthenia, 141  
     neuritis, 141  
     ozena, 137  
     rheumatism, acute, 141  
     rhinitis, atrophic, 137  
     sciatica, 141  
     stomach, 141  
     sycosis, 141  
     torticollis, 142  
     trachoma, 142  
     tubercular areas, 142  
     tubercular glands, 142  
     ulcers, 142  
     uterine diseases, 142  
     warts, 143  
     writer's cramp, 143  
     effects of, on human body, 123  
     generation of, 124  
     methods for, 124  
     glass vacuum electrodes used  
     with, 127  
     uses of, 132  
 Cystitis, 208  
  
 D'Arsonval, 113, 121, 123, 124,  
     193, 201  
 Davis, E. F., 196  
 Davy, Sir Humphry, 2  
 Deafness, 137  
 Death by electricity, 191  
     test for, 202  
 Degeneration, changes, qualita-  
     tive, 84  
     quantitative, 82  
     reaction of, 78  
     form of chart for use when  
     testing for, 89  
     method of testing for, 80  
     practical hints in testing for,  
     87  
     prognosis in, 89  
     where found, 87  
 DeKeating-Hart, 203  
 Delirium tremens, 212  
 Dercum, 201  
 Diabetes, 137  
     mellitus, 212  
 Diagnosis, 137  
     faradic current in, 73  
 Dieudonné, 182  
 Diphtheria, 212  
 Discharges, 49  
     conductive, 49  
     convective, 49  
     disruptive, 49  
 Downes, 182  
 Duchenne, 62, 65  
 Dysmenorrhœa, 212  
     congestive, 212  
     nervous, 212  
 Dyspepsia, 137, 212  
  
 Eczema, 138, 212  
 Electric cautery, 104  
     arrangement of cells for, 105  
 Electric sleep, 206  
 Electrical treatment, summary of,  
     93, 211  
 Electricity, 4  
     death by, 191  
     electrocution, 194  
     comparison of new methods  
     with the old, 196  
     definition of, 4  
     direction of flow of, 20  
     for medical purpose, production  
     of, 14  
     forms of, 4  
     continuous, 4  
     current, 5  
     production of, 5  
     d'Arsonval, 4  
     direct, 4

- Electricity, forms of, faradic, 4  
 definition of, 4  
 Franklinic, 4  
 frictional, 4  
 galvanic, 4  
 definition of, 4  
 high frequency, 4  
 indirect, 4  
 interrupted, 4  
 sinusoidal, 4  
 static, 4  
 definition of, 4  
 production of, 5  
 voltaic, 5  
 in surgery, 104  
 cautery, electric, 104  
 arrangement of cells for, 105  
 avoidance of ether with, 105  
 Bottini operation, 107  
 color of heated electrode, 105  
 conducting cords, length of, 106  
 use of platinum in, 106  
 uses of, 106  
 electroscopes, 104  
 in malignant tumors, 104  
 in the treatment of nevi, 110  
 removal of superfluous hair, 109  
 X-rays in, 110  
 Röntgen rays, 104  
 persons injured by, methods of assisting, 198  
 resuscitation of persons shocked by, 191
- Electrocution, 194  
 comparison of new methods with the old, 196
- Electrodes, 7
- Electrodynamics, 6  
 definition of, 6
- Electrolysis, 91  
 action of poles in, 92  
 adhesion of electrodes to tissues in, 95  
 definition, 91  
 element, electro-negative, 92  
 electro-positive, 92  
 in the treatment of aneurysm, 93  
 description of the wiring of, 94
- Electrolysis, in the treatment of disease, 92  
 by negative pole, 93  
 by positive pole, 92  
 in the treatment of strictures, 95  
 ions, 91  
 metallic, 95
- Electrolyte, 7
- Energy, electrical, sources of, 14
- Epilepsy, 212
- Epithelioma, 212
- Erb, 80, 206
- Erb's paralysis. See Paralysis
- Exophthalmic goitre. See Goitre, exophthalmic
- Farad, 13
- Faradic battery, 63  
 forms of, 69  
 skeleton of, 72  
 current, application of, 75  
 circuit, primary, 66  
 secondary, 67  
 core, the, 17  
 effects of, 63  
 physiologic, intensity of, 68  
 galvanic inducing force, 66  
 interrupter, the, 67  
 modes of action of, 65  
 interruptions, 65  
 use of, in diagnosis, 73
- electricity, 62  
 discoverer of, 62  
 investigations by Duchenne, 62
- electrodes, 69
- Faraday, 2, 62, 63, 91
- Finsen, 184  
 rays, 184
- Fissure in ano, 212
- Force, electric, 8  
 definition of, 8  
 electro-motive, 8  
 coulomb, 9  
 definition of, 8  
 ohm, 9  
 synonyms, 8  
 unit of measurement of, 9, 12  
 volt, 9, 12
- Franklin, 1
- Franklinization with direct sparks, 123

- Freckles, 212  
 Freudenburg, 107  
 Fritsch, 206  
 Fulguration, 203  
   dangers of, 205  
   results, 205  
 Furuncle, 212
- Gaiffe, 208  
 Galactorrhea, 212  
 Galvani, 1, 5  
 Galvanic battery, 7  
   cell, 7  
   elements usable in, 8  
   couple, 14  
   electricity, 4, 7  
   definition of, 4  
   electro-motive force of, 8  
   electrode, 34  
   electrolyte, 7  
 Galvanism, 16  
 Galvanometer, dead-beat, 193  
 Gastritis, chronic, 212  
 Gilbert, 1  
 Glands, tubercular, 142, 212  
 Glossary, 215  
 Goitre, 138, 213  
   exophthalmic, 138, 159, 213  
   reduced electrical resistance  
   in, 192  
 Gout, 138, 213  
 Gray, Stephen, 1  
 Guericke, Otto von, 43
- Hagedorn, 104  
 Hare, H. A., 94, 200  
 Headaches, 138  
 Hemiplegia, 160  
 Hemorrhoids, 139  
 Herpes zoster, 213  
 Hertzian franklinization, 123  
 Hiccough, 213  
 Hitzig, 206  
 Hutchinson, 206  
 Huyghens, 182  
 Hypertrichosis, 213  
 Hysteria, 139, 213
- Incontinence of urine, 213  
 Indigestion, 139  
   intestinal, 139  
 Insomnia, 139, 157, 213  
 Introduction, 1  
 Ions, 91
- Kellogg, J. H., 113  
 Keloid, 213  
 Kemmler, William, 192  
 Kilowatt, 13
- Laryngitis, 213  
   chronic, 140  
 Lead palsy, 202  
   differentiation of, 202  
 Leduc, Stéphane, 206  
 Lentigo. See Freckles  
 Lesion, peripheral, differentiation  
   of, 202  
 Leucorrhœa, 140, 213  
 Leyden jars, 47  
 Light and heat therapy. See  
   Therapy of light and  
   heat  
 Locomotor ataxia, 140, 161, 213  
 Lodge, Sir Oliver, 120  
 Lumbago, 140, 213  
 Lupus, 213
- Magnetic electricity, 62  
 Magnetism, 147  
   Ampère's theory of, 147  
   Bachelet's theory of, 147  
   conclusions in regard to, 149  
   electricity and, 147  
   magnetic wave, action of, 154  
   diseases treated by, 154  
   generators, 152  
   Bachelet, 152  
   method of treatment, 154  
   Maxwell's theory of, 147  
 Malignant tumors, fulguration  
   for, 203  
 Massage, vibratory, 177  
   contra-indications to, 179  
   therapeutic value of, 177  
 Melancholia, 163, 213  
 Menorrhagia, 213  
 Meralgia paræsthetica, 162  
 Meter, the, 33  
 Method, substitution, 193  
 Meyer, Willy, 107, 109  
 Milliampère, 12  
 Millicoulombs, 12  
 Minin, 190  
 Moles, 140  
 Mordhorst, 71  
 Morton, William J., 42, 44, 53, 56,  
   58, 59, 102, 119, 120,  
   121, 122  
 Myalgia, 213

- Nephritis, 213  
 Neuralgia, 141, 213  
     and neuritis, 160  
 Neurasthenia, 141, 213  
 Neuritis, 141, 213  
 Nevi, 110  
 Noë, 144
- Occupation spasm, 165  
 Ohm, G. S., 10  
 Ohm's law, 10, 12  
 Osmosis, electric, 97  
 Oudin, 122  
 Ovarian pains, 213  
 Ozena, 137
- Pains, after-, 211  
     ovarian, 213  
 Papillitis, 213  
 Paralysis, 166  
     agitans, 213  
     deltoid, 166  
     diphtheritic, 213  
     Erb's, 167, 214  
     facial, 167, 214  
     lead, 202, 214  
     musculo-spiral, 170  
     nerve, median, 172  
     ulnar, 171  
     nerves, peripheral, 171  
     serratus magnus, 170  
     sterno-mastoid and trapezius,  
     170  
 Pharyngitis, acute, 214  
     follicular, 214  
 Piffard, 71  
 Pile, the, 31  
 Polarity, tests for, 21  
 Polarization, 19  
 Poles, 7  
     effects of, on the tissues, 21  
 Poliomyelitis, anterior, 202  
     chronic anterior, 214  
     differentiation of, 202  
 Potential, 51  
 Power, electric, unit of, watt, 12  
 Poyret, 102  
 Pregnancy, vomiting of, 214  
 Prostate, enlarged, 172, 214  
     treatment of, by high frequency  
     currents, 173  
 Pruritus, 214  
 Psoriasis, 214  
 Pterygium, 214
- Raynaud's disease, 214  
 Reichenbach, Baron von, 149  
 Resistance, 10  
     decrease of, by metallic salts in  
     solution, 13  
     external, 11  
     high, 13  
     internal, 11  
     of human body, 13  
     total, 12  
     unit of, 11  
         ohm, 11, 12  
 Rheostat, 32, 34  
 Rheumatism, acute, 141  
 Rhinitis, atrophic, 137  
 Richardson, 102  
 Richman, 1  
 Ruhmkorff, induction coil of, 63  
 Russ, 210
- Sarcoma, 214  
 Sciatica, 141, 174, 214  
 Seebeck, 144  
 Sinusoidal current, 111  
     cycle, 111  
     definition of, 111  
     effects of, 112, 113  
     frequency, 111  
     methods of application of, 114  
         constipation, 115  
         diabetes, 114  
         muscles, atrophied, 115  
         paralysis, muscular. passive  
         exercise in, 114  
         neuralgia and neuritis, 115  
         obesity, 114  
         pelvic disease, 116  
         periodicity, 111  
         electric bath, 116  
 Sleep, electric, 206  
 Smallpox, treatment of, by means  
     of red light, 189  
 Snow, Dr., 54, 175  
 Spasms and tremors, 174  
 Special therapeutics. See Thera-  
     peutics, special  
 Spectrum, colors of, 182, 189  
 Spitzka, E. A., 194  
 Static electricity, 42  
     electro-motive force of, 8  
     high frequency current, 42  
     methods of applying, 52  
         electric bath, 52  
         electric spark, 53  
         electric spray, 52

- Static electricity, method of applying, Morton wave-current,**  
 53  
   static head breeze, 57  
   insulation, 57  
   Morton's static induced current, 42, 119  
   modifications of, 42  
   d'Arsonval, 42, 120  
   Oudin, 42, 120  
   Tesla, 42, 120  
   potential of, 52  
   properties of, 44  
   induced current, 58  
   method of employing, 59  
   direct spark, 60  
   induced spark, 60  
   multiple spray, 60  
   new spray, 61  
   pencil discharge, 61  
   roller massage, 60  
   single spray, 60  
   influence machine, 42, 43  
   machine, drying, 49  
   loss of charge in, 51  
   tests for polarity on, 50  
   machines, 43  
   electrodes for, 43  
   Holtz, 43  
   influence, 42, 43  
   Toepler, 43  
   Toepler-Holtz, 43  
   Voss, 43  
   Wimshurst, 43  
**Stomach,** 141  
**Stricture of urethra,** 214  
**Sycosis,** 141  
**System, three-wire,** 28  
  
**Tait,** 206  
**Tattoo marks,** 214  
**Tesla,** 121, 122, 123, 125  
**Therapeutics, special,** 158  
   abscess of brain, 158  
   anesthesia, 158. See also Cataphoresis  
   cerebral diseases, 159  
   chorea, 159  
   goitre, exophthalmic, 159  
   hemiplegia, 160  
   hysteria, 160  
   insomnia, 161  
   locomotor ataxia, 161  
  
**Therapeutics, special, melancholia,**  
 163  
   meralgia paræsthetica, 162  
   neuralgia and neuritis, 164  
   occupation spasm, 165  
   paralysis, 166  
   deltoid, 166  
   Erb's, 167  
   facial, 167  
   musculo-spiral, 170  
   serratus magnus, 170  
   sterno-mastoid and trapezius, 170  
   nerve, median, 172  
   ulnar, 171  
   nerves, peripheral, 171  
   prostate, enlarged, 172  
   treatment of, by high frequency currents, 173  
   sciatica, 174  
   spasms and tremors, 174  
   underlying principles, 158  
   varicose ulcers, 174  
   vomiting of pregnancy, 175  
**Therapy of light and heat,** 177  
   actinic rays, 178  
   sources of, 179  
   actino-therapy, 179  
   blue light, 185  
   effects of colored light, 177  
   Finsen apparatus, 177  
   incandescent electric light lamp, 184  
   rays, Finsen, 180  
   rays, sun's, 179  
   heat, 179  
   actinic, 179  
   chemical, 179  
   light, 179  
   luminous, 179  
   thermic, 179  
   summary, 185  
   treatment of smallpox by means of red light, 185  
   violet ray therapeutic lamp, 182  
  
**Thermo-electricity,** 144  
**Thermopile,** 144  
**Tic douloureux,** 214  
**Titus,** 169  
**Torticollis,** 142, 214  
**Trachoma,** 142, 214  
**Treatment, electrical, summary of,**  
 211



Units, systems of, 10  
 fundamental, 10  
 practical, 10  
   ampère, 10  
   ohm, 10  
   volt, 10  
   watt, 10

Ure, 2

Urine, incontinence of, 213

Uterine diseases, 142

Uvula, elongation of, 214

Varicose ulcers, 174

Vibratory massage. See Massage,  
 vibratory

Volta, 1, 5, 9

Voltage, 8

Voltaic electricity. See Galvanic  
 electricity

Vomiting of pregnancy, 175, 214

Warts, 143, 214

Watt, definition, 12  
 hour, 13

Wesley, Rev. John, 2

Writer's cramp, 143, 212















Original from  
UNIVERSITY OF MICHIGAN



