

## Bro. J. Ralston Skinner and the Great Pyramid measures.

[Cincinnati? 1887?]

<http://hdl.handle.net/2027/hvd.tz1s9u>

# HathiTrust

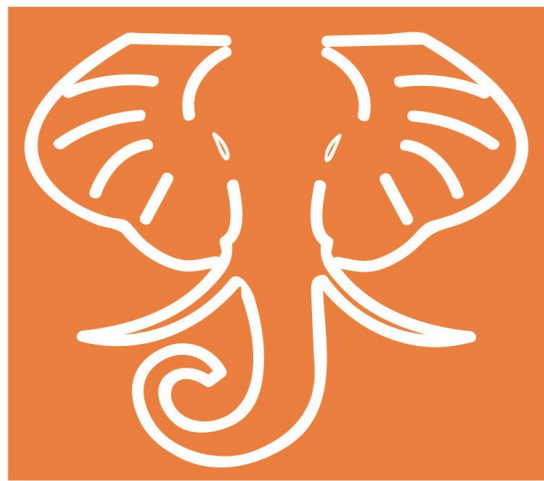

[www.hathitrust.org](http://www.hathitrust.org)

**Public Domain, Google-digitized**

[http://www.hathitrust.org/access\\_use#pd-google](http://www.hathitrust.org/access_use#pd-google)

We have determined this work to be in the public domain, meaning that it is not subject to copyright. Users are free to copy, use, and redistribute the work in part or in whole. It is possible that current copyright holders, heirs or the estate of the authors of individual portions of the work, such as illustrations or photographs, assert copyrights over these portions. Depending on the nature of subsequent use that is made, additional rights may need to be obtained independently of anything we can address. The digital images and OCR of this work were produced by Google, Inc. (indicated by a watermark on each page in the PageTurner). Google requests that the images and OCR not be re-hosted, redistributed or used commercially. The images are provided for educational, scholarly, non-commercial purposes.

TOZZER LIBRARY  
E 045 T 71

PYRAMID MEASURES.

Digitized by Google

Original from HARVARD UNIVERSITY

HARVARD UNIVERSITY



LIBRARY

OF THE

PEABODY MUSEUM OF AMERICAN  
ARCHAEOLOGY AND ETHNOLOGY

GIFT OF

Robert Clarke

Received June, 1887





2

[FROM THE MASONIC REVIEW for April, 1880]

LIBRARY OF THE  
PEABODY MUSEUM

ALSTON SKINNER, AND THE GREAT  
PYRAMID MEASURES.

"The International Standard," to which  
already referred. It is a handsome and  
Alston Skinner, whose researches  
with their results, have attracted  
the attention of the  
Academy of Sciences, Paris, and the  
Royal Society, London.

Alston Skinner  
J. R.  
Skinner J. R.

Prof. H. N. Putnam  
with regards of  
Robert Clarke.

J. R. Skinner

O.K

LIBRARY OF THE  
PEABODY MUSEUM

~~Famphlet~~

LIBRARY  
OF THE  
Peabody Museum of American Archæology and Ethnology  
IN CONNECTION WITH HARVARD UNIVERSITY  
PRESENTED BY  
*Robert Clark*  
Received *June, 1857*

**BRO. J. RALSTON SKINNER, AND THE GREAT  
PYRAMID MEASURES.**

The following is from "*The International Standard*," to which valuable magazine we have already referred. It is a handsome and honorable tribute to our Bro. J. Ralston Skinner, whose researches in Pyramid science and measures, with their results, have attracted the attention of the scientific world.

Through the kindness of Bro. Charles Lattimer, Editor of the *Standard*, we are privileged to present to our readers the *Diagram*, to which the article refers :

We present in this number a diagram giving the measures of the Great Pyramid. It is taken from a work by Mr. J. Ralston Skinner, of Cincinnati, entitled, "Crown Jewels of the Nations," a supplement to "Source of Measures." We desire to call the attention of our readers particularly to these books, because they so clearly show the British inch to be the foundation of the system of measures of the Great Pyramid, the measures which have been apparently miraculously preserved and transmitted through the Anglo-Saxon race.

Many Pyramid measurers claim that there is also a Pyramid inch which exceeds the British inch by one-thousandth. Mr. Skinner has always maintained that the British inch was the true measure.

If there is a Pyramid inch agreeing with the solar time measures, there must be a difference every year, as the solar year varies. According to Prof. Stockwell, this solar year 2170 B. C. was 365 days, 5 hours, 49 minutes, 7 26 seconds, or 20 seconds longer than the present. Now, if we say that the Pyramid inch agrees with the solar period as it was 2170 B. C., it would not agree with our solar year, therefore we must have some fixed unalterable measure from which to count. If it be the polar axis, will that polar axis always agree to the remotest fraction with the solar time? Prof. Stockwell asks: "Why not take the sidereal year, which is fixed, being by latest observations of Hanson, 365.2563582?" Who will answer?

We pass these questions for the present and give the diagram of Mr. Skinner for the purpose of eliciting discussion and of giving



H.D., Apr. N.E. SK 35  
 o. of Robert Cicca  
 Rec. Ex. 1227 2

SUPPLEMENT TO SOURCE OF MEASURES  
 INTERIOR WORKS OF GREAT PYRAMID OF EGYPT

J. R. S. March 15<sup>th</sup> 1870.  
 Measures in British Feet.

SCALE 350

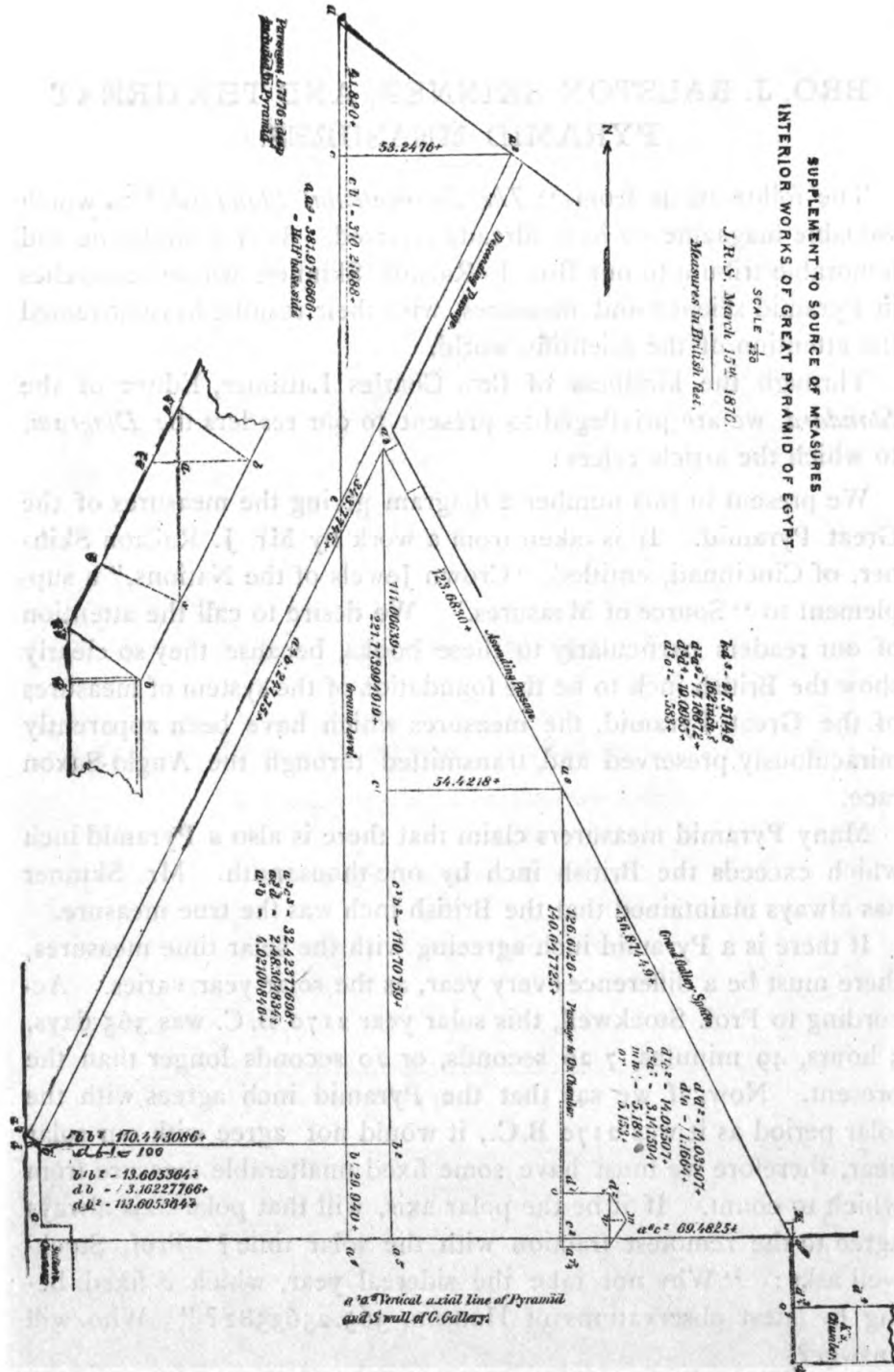

1278  
 111

credit where credit is due for the discovery of the main important fact that the British measures fit with the measures of the Pyramid, and are correlated with the circle of 360. There is one important point which is to be specially noted, namely, that although Mr. Skinner does not deny that the southeast socket is the terminal point of the base of the Pyramid, yet he maintains that there is also a base indicated which is represented by 2400 divided by  $\pi$  for feet, which would give the base length of Howard Vyse of about 9168 inches. The measures of Petrie make the base length of the S. E. socket 9139.871258, while Mr. Skinner's measures in inches give 9167.32 at the lower level. Of course this would be proportional and near to the other with the same slope of the Pyramid. It is for Pyramid students to compare the Pyramid chart and Mr. Skinner's diagram in British inches with subsequent discoveries to ascertain if it is possible for the base of the Pyramid to extend below the southeast socket. Whatever may be the conclusion in relation to that, the fact remains indisputable that the measures of the Pyramid given by Piazzzi Smyth and by all other reliable measures fit completely with the British measures in correlation with the circle of 360. The Pyramid chart published by the society was drawn by the advice of Mr. Skinner, to prove that the British measures were those primarily used by the architect, and we reproduce it here on a smaller scale.

He does not deny the existence of the Pyramid inch, but insists that the British measures were the foundation. Without his discovery we would yet have been groping in the dark. Nevertheless there is a Pyramid inch agreeing with time and sacred chronology and the British measures.



# To Obtain the Length of the Hypotenuse of a Right-Angle Triangle, its Sides Being Given, Without Extracting the Square Root.

By J. RALSTON SKINNER.

To the pure geometrical solution, that the square of the hypotenuse of a right angle triangle is equal to the sum of the squares of its remaining sides, for the object of obtaining the length of the hypotenuse by the process of extracting the square root, is added a tentative mode of calculation to finally get that length.

For, and in place of this mode, I offer the following, which has the property of clearly showing intermediate constructive processes of geometrical shapes, and also of showing at each step, the residual quantity, in geometrical shape or area, with its determined value, as a *plus* or *minus* quantity.

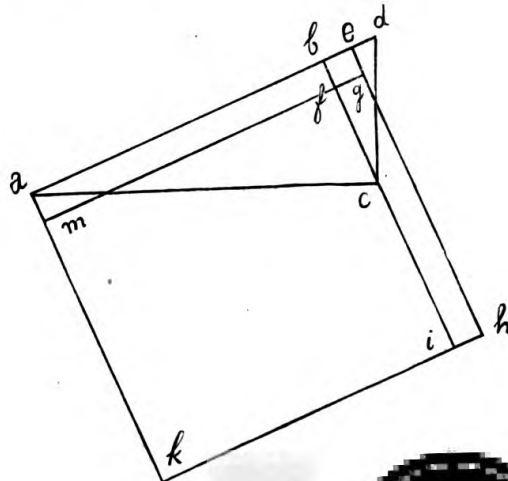

Let  $abc$  be a right angle triangle, whose sides  $ab$  and  $bc$ , are, respectively, 16 and 7 (or any other numbers), to find the length of the hypotenuse  $ac$  *without extracting the square root*;—by the Pythagorean Problem, the sum of the squares of 16 and 7, or 256 and 49, being equal to the square of the hypotenuse,  $ac$ , or 305.

The side  $bc$ , or 7, is a mean proportional, such, that  $16 : 7 :: 7 : 3.0625$ ,—represented by  $bd$ , the prolongation of  $ab$ . It is by the discovered use of this mean proportional that the problem is solvable. By this, as seen,  $3.0625 \times 16$ , the side  $ab$ , gives 49, or the square on  $bc$ ,—which area must be added to that of 16 square, or 256, to equal 305, the square on the hypotenuse:—consequently, the half of the area of 49, shown by a rectangle 16 long by 1.53125 wide. Divide  $bd$  in halves, or by 2, to equal the length  $be$ , or 1.53125, and add this as the continuation of  $ab$ , or 16, or  $ab + be = 16 + 1.53125$ , or 17.53125, and complete the squares  $ae hk$  and  $begf$ . Continue  $bf$  to  $i$ , and  $gf$  to  $m$ ; then we will have the interior square  $fmki$ , whose side is 16, and area 256,—the two rectangles  $abfm$  and  $fghi$ , each of which is 16 long by 1.53125 in width, containing, each, in area, 24.5, or, together, 49;—so that, these two rectangles, with the square  $fmki$ , will equal 305 in area, or the square on the hypotenuse. There will be left in the square  $ae hk$ , the small square  $begf$ , whose sides are, respectively, 1.53125 in length. With these elements the square  $ae hk$  is to be reduced in area until a square will result whose area is 305, or that of the square on the hypotenuse  $ac$ .

Determine the area of the square  $begf$ ; it will be 1.53125 squared, or 2.34472+. But this area is to be taken from the areas  $abfm$  and  $fghi$  (together 49). Therefore, divide 2.34472+ by  $16 \times 2 = 32$ , and a rectangle will result 32 in length by .0732727+ in width; so that the rectangles  $abfm$  and  $fghi$ , will be reduced in width *only*, and will now remain as, each, 16 long by  $1.53125 - .0732727$ , or 1.457977+ wide; and the sides  $ka$  and  $kh$ , will each have become 17.457977+ in length. The square  $begf$ , has now a filled area, taken from the large rectangles, of, as said, 2.34472+, which contains a smaller square of 1.457977+, for the length of its sides, with an area of 2.125697+, which last square can now be added to the rectangles  $abfm$  and  $fghi$ , to make a complete square, whose sides will be, each,  $16 + 1.457977+ = 17.457977+$  in length. But the area of this

smaller square, of  $1.457977+$  to the side, or  $2.12567+$  is less than that of  $be gf$ ;—or, there is an excess of area of  $be gf$  over the small square of  $2.34472+$  less  $2.125697+$  or  $.21902877+$  as shown by this diagram.

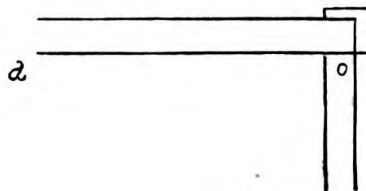

This excess of area, however, is part of the area of  $305$ , which must still be used to complete the perfect square on the hypotenuse  $ac$ ,—and as  $ab$ , or  $16$ , has now become  $ao$ , or  $16+1.457977+$  or  $17.457977+$ , this surplus area of  $.21902877+$ , is to be divided by this length multiplied by two, for a rectangle of area of this length, to be added to the general figure. So,  $.21902877+$  divided by  $17.457977 \times 2$  ( $=34.91595+$ ), will give a rectangle of this length, by  $.006274+$  in width, to be so added to the two sides of the great square that they will now be, for the side  $ak$  and  $kh$ , each,  $17.457977+$  plus  $.006274+$  or  $17.4642513+$ ;—which rectangles, thus added, will form a perfect square, *with the lack of a small square*, whose area must, again, be filled up as before, whose sides, respectively, are  $.006274+$  in length, as shown by the diagram.

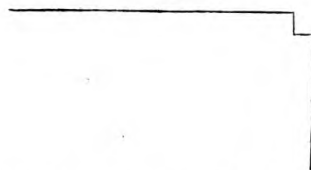

The *square root* of  $305$ , extracted by the usual process, is  $17.464249+$ , and, for comparison, the last determination, by the foregoing process, is  $17.464251+$ ; showing an excess at this stage, of *one* in the *fifth* decimal place, which illustrates the rapidity of the process. Of course the process can be continued on indefinitely. It will be observed that no step has been taken, in calculation, which is not terminable as a *vulgar fraction*, and, therefore, the process is *an integral one in this respect*; and, besides this, as said before, the resultant *excess* or *deficiency*, is always as exactly determined,—thus making the whole process *rational, limited*, and freed from *surd* expressions for square root.

Another display may be resorted to, to show reference to a common base of operation, viz., a common base of  $a b$ , or 16. The area 49, divided by 16, is 3.0625, giving one rectangle. The area 256 divided by 16 is 16 by 16 for the second rectangle. And 305 divided by 16 is 19.0625 or  $16 + 3.0625$ , for the third rectangle. These may be arranged on a common base of 16 to the side, and the square  $a e h k$  can be derived. Q, E, D.

The *rationale* of the above process is simple. The use of *the mean proportional* enables us to complete by figure the two rectangles  $a b f m$  and  $f g h i$ , whose area is, each, the half of the square of the altitude  $b c$ ; with the perfect square  $b e g f$  (the complement to make the perfect square  $a e h k$ ) as the known residual space to work with.

The whole process is *integral*, and not *irrational* or "surd," as the expression goes. For instance: —  $16 : 7 :: 7 : 3\frac{1}{8}$  or 3.0625. This  $3\frac{1}{8}$  squared is  $11\frac{1}{4} = \frac{45}{4}$ . This  $\frac{45}{4}$  squared is  $\frac{2025}{16} = 126.5625$ . So  $\frac{2025}{16}$  divided by  $3\frac{1}{8} = \frac{2025}{16} \div \frac{25}{8} = \frac{2025 \cdot 8}{16 \cdot 25} = \frac{16200}{400} = 40.5$ , and so on throughout. In other words, one need not have any decimal expression in the whole calculation.

No doubt there are other devices to be discovered by the newly found use of this mean proportional, in shape and value, and comparative relation, as simple of solution as the above, where hypotenuse and one of the sides are given; and, moreover, I am satisfied, there is just as simple a mode, to be discovered, by which the full and exact value of the hypotenuse is to be obtained.

*Corollary*,—to find the side of any square, its area being given, without extracting the square root. Find by trial of some even number a square area which the given area will contain, the larger the better. Deduct this area from the given area. Divide the remainder by the length of side of the assumed square multiplied by two, for the two rectangles  $a b f m$  and  $g h i f$  spoken of above. Then for length of side required, reduce as by the above process.

CINCINNATI, Sunday, Jan. 17, 1886.

[From the MASONIC REVIEW, July, 1885.]

### HEBREW METROLOGY.

By Bro. J. RALSTON SKINNER, (McMillan Lodge, No. 141.)

This article having reference to measures strictly, was prepared for the Anti-Metric Society, of Cleveland, and published in the International Standard. It is proper to state that the newly discovered mode of language, veiled under the words of the Sacred Text, so far from in any way impairing the idea of Divine power, obligation and inspiration as belonging to the Holy Bible, serves but to strengthen, re-inforce and confirm it.

The subject of Hebrew Metrology, as ordinarily thought of and accepted, is not to be touched on in this paper for want of space. It would at any rate, be but repetition of that which can be gleaned from many works.

Tentatively we have discovered that the *radius seconds* of the circle of 360 *degrees*, viz., 206,264.70+ seconds, practicalized in measure as 20.<sup>626470</sup> imperial British inches, was an ancient Egyptian *cubit* value—the so-called *Nilometer* cubit. But in the numerical value of a proportion is the natural outgrowth or development of, geometrically, a *pi* value, wherein the *pi* ratio is 20,612 for circumference of a circle, to 6,561 for diameter. The proportion is this: 20,612 : 6,561 :: 64,800 : 20,626<sup>470</sup>. And, indeed, 20,612 was utilized in like manner as a measure in the same standard (British inches), so that 20.<sup>612</sup> such inches made the length of another of the Egyptian cubit measures, the so called “Turin” cubit. By actual microscopical tests by Bidone and Plana (Seyffarth) the Turin cubit measured 20.<sup>61172</sup> British inches, and by Wilkinson the Nilometer cubit measured 20.<sup>625</sup> British inches.



The application of these cubic measures to the best reported measures of the Great Pyramid, proves that the cubits were derived from the above formula ; as to which the actual cubits referred to show so close an approximate.

The learning of the Egyptians was that of the Hebrews, and there is demonstration that the most sacred measure of the Hebrews was the Turin cubit and its derivative, the Nilometer cubit. From this proportion 20,612 to 6,561 (which was esteemed in Holy Writ as true  $\pi$ , and beyond doubt is\*) the modified form of 355 to 113 is to be obtained. (See 'Crown Jewels of the Nations are Their Measures.') From these two ratios, viz: 6,561 to 20,612 and 113 to 355, the entire system of sacred metrology of the Hebrews took its rise, as is found demonstrated in the Hebrew text of the Holy Bible, especially in Genesis and the five books of Moses. One may imagine how sacred these measures must have been esteemed, when it can be said that on the ratio 113 to 355 rested what is called in the Sacred Record the "*Man even Jehovah*" measure (Genesis iv : 1), and that this rested for its origin upon the radical one of 6,561 to 20,612.

The Old Egyptians used the archaic Coptic language which was a dialect of the Semitic; from which last the Hebrew also. Ancient Ethiopia extended on a parallel from the mouths of the Nile and head of the Red Sea across to the head of the Persian Gulf. The use of the Hebrew language is traceable as progressing up the Euphrates, from this gulf, and this language is a veil or cloak for the setting forth the same system of science which the Great Pyramid, on the bank of the Nile, contains builded in stone. Moreover, the esoteric use of the Hebrew language extended to the Pelasgians or archaic Greeks, and the Dardanians,—became the basis through the historical myth of the Trojan War, by Homer, of the highest ideal conceptions of Grecian civilization,—passed over to Rome,—and from all these down to the present day, preserved by means of pertinent and enduring landmarks.

The interior, or sacred metrology, was not open with the Hebrews any more than with the Egyptians. To illustrate this: as said, the Nilometer cubit is found to have been 20.<sup>626470</sup> British inches in

---

\*It may be interesting to those who are not aware of the fact to know that Professor Roche of Philadelphia, has by the simplest application of the rules of Euclid, shown geometrically the exact equality of a square for any given circle in area; and this shows essential error in what is called established  $\pi$ .

length; but if an Egyptian cubit stick of this length, or of the length of  $20.612$  of such inches was examined it would be found that no division of the same would show any relation whatever to the British inch, or any denomination of measure founded thereon, as the foot, etc. Thus the workman would be in complete ignorance of such relation as belonging to the measure he was using.

The secret, as we have empirically and tentatively discovered, lay in this, viz: the knowledge and use of the Imperial British inch, and the denominations based on it, existed as a knowledge separate and secret and sacred. Either of the cubits mentioned was known, to those possessing this secret; in its totality, to be the one  $20.612$  of such secret, sacred inches, and the other  $20.626470$  thereof; and from these, by the transference of certain uses of the cubits themselves into this new realm of measure, an especial interpretation, perfect in its coherences and applications, as, for instance, to astronomical times and cosmic distances, etc., was made.

As to metrology: Instead of a valuable adjunct to the Biblical system, having mentioned here and there in the Sacred Text, the entire text of the Holy Writ, in the Mosaic books, is not only replete with it, as a system, but the system itself is that very thing, *in esse*, on which, and out of which, and by the continuous interweaving use of which the very text of the Bible has been made to result, as its enunciation, from the beginning word of Genesis to the closing word of Deuteronomy. For instance, the narratives of the first day, of the six days, of the seventh day, of the making of Adam, male and female, of Adam in the Garden, of the Garden itself, of the formation of the woman out of the man, of the extension of the time to the flood with the genealogy, of Ararat, of the Ark, of Noah with his dove and raven, of the space and incidents of Abram's travel from Ur of the Chaldeans down into Egypt before Pharaoh, of Abram's life, of the three covenants, viz: with Noah, with Abram, and at Sinai, of the construction of the Tabernacle and the dwelling of Jehovah, of the famous 603,550 as the number of men capable of bearing arms who made, with their families, the exodus out of Egypt and the like—all are but so many modes of enunciation of this system of geometry, of applied number ratios, of measures and their various applications. This system, as said, embraces, for a part thereof, that same one which we find conclusively to be embraced in the structure of the Great Pyramid.

This system is a language in, of and by itself, which, moreover, embraces much which at first seems apart and separate from the discussions of exact science and astronomy, viz : for example, man in his various conditions and relations to what we call God, and also to nature, especially in the department of the exertion of the parturient energies. The reading of this language is an outgrowth from, in harmony with, and partly determined by, the visible and first face text. To the extent to which this language was known among the Jews, the learning and teaching thereof was called Cabalah.

In the narrative form man himself, as the Adam, the Archetypal Man, the Adam Kadmon, was taken as the grand representation and containment of this entire system. In himself he was considered as the reflection of the Component parts or nucleations out of the Willing, Intellectual, Unknown, Incomprehensible First Cause; and thus became, in substance, thought and conception, the exponent as to all that came within his knowledge of that First Cause as to the phenomena of its operations; Itself thus, in him, becoming personal out of the impersonal. Hence in and of himself he contained this very system, which became in the text of Holy Writ, expounded in its chief words of nomenclature through himself and his names. As the First Cause was utterly unknown and unnameable, such names as were adopted as most sacred, and commonly made applicable to the Divine Being, were, after all, not so, but were such manifestations of the First Cause, in a cosmic or natural sense, as could become known to man. Hence these names were not so sacred as commonly held, inasmuch as with all created things they themselves were but names or enunciations of things known, either by experience or revelation. The ratio to which belonged 20,612 and 20,626 were those from whence came literal and matter of fact measures, which, in turn, took names from the members of the man. Thus the Hebrew system of measures rested on the thumb's breadth, the digit, the palm, the span and the cubit. These measures were made, by a beautiful mode of construction, to coördinate measures of space with those of time. By the very fact that they borrowed from a man his members as a mode of nomenclature, so in the comprehensive term man himself, in the numbers of his name, viz : 113 was found a typical and subordinate source or mode of measures, peculiar to themselves, in use and application and intendment.

To somewhat explain this, let us refer to the canon of Vitruvius as to the rules or architectural modes of construction of temples to the immortal gods by the Greeks. Suppose the circle of the base of a column, for esoteric measures to have been taken from the form of a man stretched out on the ground looking upward, so that taking his navel as a center, the circumference line was made to touch the extremities of his outstretched fingers and toes. Now this man, thus occupying this space, might be held to be the typical or man measure of the base of this column, out of which and constructed with which should belong the attending circumstances of height, shape, capital, grooves or flutings, *et cetera*, of the column; and all this to grow out of the ideal and merely abstract number of his name, irrespective of whatever actual measures might be given to such a column, as so many cubits, palms, digits, or what not. Thus this column, irrespective of its actual measures, could be read in terms of its ideal abstract typical ones, as for instance: *Man* is 113; this is diameter to 355 for circumference, and 355 for one thing indicated the measure of the lunar year, (*Shanah*) in the natural measure of days, and at the same time was the proper name Pharaoh. So, also, 355 is the outgrowth of the use of the word *dove* in the flood narrative, for its value is 71, it is used five times and  $71 \times 5 = 355$ . Now, to resume, suppose that for height the base of the column, or man measure, should for this purpose be taken for the length of the foot of the man, and by a rule of construction the height of the column should be taken as six times the length of the foot. Thus, the base being 113 (for *man*) then the height would be  $113 \times 6 = 678$ ; and this is the value of the letters used for that other bird mentioned in the flood narrative in the expression or word, *āth-h' orebv* (*sic*, in the text, as connected by hyphen) "*and-the-raven*," the values of the letters of which give as their sum this same number 678. The diagram of this conception was a circle whose circumference was 355, it being the measure in days of the lunar year, and this number is the Hebrew word *Shanah*, the name of that year. The description in the Bible of the flight of the *raven* was that it went "*to and fro*," which expression determines the use of this number 678. For the diameter of this circle of 355 being 113 if 6 such diameter lines are used to divide this circle "*to and fro*," into equal parts, 678 accomplishes this result:—for  $113 \times 6$  equals 678: which simply shows a scheme of the division of the lunar year of 355 days into

12 parts or months. Thus one can see that running along with actual measures is a typical system and use of same. This raven use of the numbers 678 is of great significance and found in various places; for instance: We have it first as the prototype in the flood narrative. We also have it as the deepest underlying key to Grecian architecture in its inception, and, moreover, Rawlinson, in his 'Herodotus,' says that the word is that from whence the name Europe.\* We have it to-day, in such uses as causes the utmost amazement and surprise at the continued familiar use to some who must now be initiates of this kind of learning. But what is of the most interest to us is that the use crops out in the Great Pyramid. One of the most wonderful places in the structure is found in the attainment of the surface of the great step, where one arrives to the plane of the floor and open entrance to the Holy of Holies, or the king's chamber. The height of the grand gallery from the face of this step is 339 British inches. This is radius to a diameter of  $339 \times 2 = 678$  inches, or this very raven number. The radius is taken to show division into two parts, a favorite use, which are 1065 each. For the ratio 113 to 355 multiplied by 3 equals 339 to 1065. Now the numbers 1065 are the significant ones of Jehovah's name, viz: *jod, vav, hé*, or 10 and 6 and 5, which the rabbin's extol so beyond all other numbers and say that by their uses and permutations, under the law of *T' mura*, the knowledge of the entire universe may be had. The entire circumference will be  $1065 \times 2 = 2130$ , of which 213 is the factor with 10; and 213 is the first word in Genesis, viz: *Rash*, or *Head*, from whence the entire book. By one of the permitted changes 1065 becomes 1056, and in this we have the numbers of Mt. Sinai and those to show the descent thereon of Jehovah in a bush of fire, the chief object of the use of which numbers, so arranged and applied on the Mount, is to afford as a result the *exact* astronomical value of the lunar year, viz:  $354^{8670548}$  days—that is, in natural measure. Besides this, and what is most remarkable, is the fact that these same numbers, under the letters given, were introduced into China some twelve centuries prior to the Christian era, and taught by

\* The name Ionians signifies "The People of the Dove," applying to Greece and Asia Minor. The term was taken from the religious *culte* of the *Dove*, which afterward became invoven in the narratives of Christianity. The *West* or land of darkness, or of the setting sun, took its name from the Hebrew word for *raven*, for this word is o-r-bv, or Eu-r-bv, or Eu-r-pv, or finally Europe.

Wang, and quoted by Laouitz, the preceptor of Confucius, as the root and base of all knowledge, under the form of an enigma or riddle.

The distinction between the two branches of this general system, viz: between the actual measures from the ratio 6561 to 20612, and the ideal abstract *man* measures, from the ratio 113 to 355, gives rise to two great and well settled distinctions in the Mosaic Books. As a use, derivative and reduction from the first, we have the great God-word *Elohim*. The running characterizing small numbers of this name, in Hebrew, are 13514, which, placed on the bounds of a circle, will serve to give expression to the measure of the same; for they can be read as 31415, which is what we to-day call the value of  $\pi$ , and is so significant as to be used in astronomical tables as a *constant co-efficient*, that is, it is the numerical value of the circumference of a circle whose diameter is *one*; hence the Biblical expression by the rabbins: "His name is *Echod*," or *One*. This is the distinctive, so-called, *Elohistic* branch. As a distinctive use under the second, we have the "measure of a man," or 113, which also is significant of a  $\pi$  value, inasmuch as it is diameter of a circle to a circumference of 355. But in its Biblical origin, Genesis, chapter iv, verse 1, it is called the "Man Even Jehovah" measure; and this is obtained in this way, viz:  $113 \times 5 = 565$ , and the value 565 can be placed under the form of expression  $56.5 \times 10 = 565$ . Here the *man* number 113 becomes a factor of  $56.5 \times 10$ , and the reading of this last number expression is *jod hé vav hé*, or Jehovah. Hence this is the distinctive, so-called, *Jehovistic* branch of these books. The expansion of 565 into  $56.5 \times 10$  is purposed to show the *emanation* of the male (*jod*) from the female (*Eva*) principle; or so to speak, the birth of a male element from an immaculate source; in other words, an immaculate conception.

In Al-Chasari, by Hallevi, written in the twelfth century, the author clearly shows the distinction between the names *Elohim* and *Jehovah*, in this, viz: that the first is a generalized term, serving as a constant as entering into all created works and forms whatever, while the name *Jehovah* is a particular or discrete manifestation of most especial value to man because of His immediate intervention in and superintendence over man in all the most cherished details of his being, especially in the department of conception and birth, *i. e.* as the energizing activity.

I now assert that what has been said can be proven to demonstration from the holy books, and then reinforced and confirmed by a multitude of supporting facts, scattered all along down through history and tradition. It all goes to show that the world of thought and study, through these thousands of years, has, in accepting the Biblical record on its first face reading only, been taking the *shadow* for the *substance*; and hence the interminable difficulties and unending changes of exegesis.

And in view of this, let me close this contribution with two quotations—one from Schopenhauer and one from Ralph Waldo Emerson.

Schopenhauer, in 'World as Will and Idea,' says :

In the idea of perception, illusion may at moments take the place of the real, but in the sphere of abstract thoughts (such, for instance, as compose the religious philosophy and Biblical exegesis of our day) error may reign for a thousand years, impose its yoke upon whole nations, extend to the noblest impulses of humanity, and, by the help of its slaves and dupes, may chain and fetter those whom it cannot deceive.

Ralph Waldo Emerson says :

The religion that is to guide and fulfill the present and coming ages, whatever else it may be, must be intellectual. The scientific mind must have a faith which is a science, at first cold and naked, a babe in the manger again, the algebra and mathematics of ethical law, the church of men to come, without shawms, psaltry, or sackbut; but it will have heaven and earth for its beams and rafters, with science for its symbol and illustration; and it will fast enough gather beauty, music, pictures and poetry.

[From the MASONIC REVIEW for October, 1885.]

## The Doric, Ionic and Corinthian Columns

IN GRECIAN ARCHITECTURE.

By Bro. J. RALSTON SKINNER, (McMillan Lodge, No. 141.)

Vitruvius, who wrote in the time of the first Cæsars, gave to the world the rules of construction of the Grecian Temples to the immortal gods. One of his principal themes was the subject of measures; and part of this, by reason of ignorance, has been unfavorably criticised, though always commented on. Part of this one related to the proportions of *a man*,—as that *his height* was *six times* the length of *the foot*; whereas, as a general factor for the relation, *seven times* that length will be found to be very accurate. The form of man being considered as the reflection or image of the Divine Creator, it was taken in its proportions as the proper source from whence measures were to be derived,—as the digit, thumb's breadth, span, cubit, and so on. Then, since there should be harmonic coordination in all things, as being at last referable to One Creative Idea, man being the express image of the same, all conceptions of beauty, grandeur, rightness, holiness, and the like, should somehow be referable back as related and pertaining to that system of measures and their symbolic uses; precisely the same as Masonry teaches, under its own modes of measures and their symbolic applications.

In the article in the July number of the REVIEW, on Hebrew Metrology, reference is made to the use of the man (Man Even Johovah) measure 113, as being the diameter of a circle whose cir-



cumference is 355.—the use of which Vitruvius referred to in a veiled way, as carried along by intendment with the more ordinary measures of the cubit and its divisions. 335 being the number of days in the lunar year the significance of the use is astronomical; and that as seen upon the geometrical basis of the circle and its diameter. It was upon this use that Vitruvius gave his proportion of the height of a man to the length of his foot, about which much dissenting comment has been made. But he did this knowingly, as an adept or secret master, and for physical fact made the proper correction after the first proposed use. He says the height of the Doric column being *six* times its diameter, this was changed in converting the Doric into the Ionic by giving to the column a height of *seven* times its diameter; which may be taken as a general measure of great accuracy.

Let us give the construction, under the esoteric rules of Vitruvius, of the temple and its columns.

First: The temple in its greatest embracement should be an oblong of two squares, as *the invariable law*. This was the pattern of the King's Chamber of the Great Pyramid of Egypt, then next in point of time, of the Tabernacle of Moses, next of the Holy of Holies of the Temple, as divided by the wings of the Cherubim, as also of the porch of the same,—divided as to its length of 20 cubits into 3 equal spaces by the pillars Jachin and Boaz, the distance between them being diameter to a circle having a circumference, in Masonic feet, of 360 degrees. So the rule was not of Grecian invention but derived from the Hebrews; who, in turn, had the same in two lines of descent, one from the head of the Persian Gulf by way of Babylon, and one from Egypt. The succession of this rule by right of inheritance and practice belongs to-day to Freemasonry.

Second: As to the columns, they were after all, to be read by the ideal measures of *a man*, while constructed in terms of the real measures of the cubit and its parts. The first use was of a man lying on his back, with his limbs outstretched, so that, the navel being taken as a center, a circumference line would touch the extremities of his fingers and toes. It appears that Leonardo da Vinci made a study of this rule, and among his manuscripts there was lately found a drawing of this crucified, or crossified, man; a copy of which is to be met with in a late pamphlet by Dr. Fletcher, of Washington, on the true proportions of the human form.

This was the circular base of the column, as interpreted by symbolism and numbers from the form of *a man*; and the numerical proportions were to be had from the Hebrew term for man;—from whence the Grecian idea. As said, the word *man* in Hebrew, gives the small or characteristic numbers of the letters of the word as 113. Thus, the diameter being taken as that of a man, irrespective of its measures in cubits and part thereof, the circumference of the column would be 355, or the number of days in the lunar year.

This circle divided into twelve equal parts by six diameter lines of 113, each, (the going “*to and fro*” of the raven in the Noah description) would show division of this lunar year into twelve months, the aggregate value of the same lines being  $113 \times 6 = 678$ ;—which, as said, was the value of the description of the raven in the word “*and-the-raven*” in the Flood narrative.

By Vitruvius, the Doric column, representing the height of a man, should be six times the length of his foot, and its diameter being 113, six times this, taken as the length of the foot where the height comes in question, would be 678, or this very number. But as to this, Vitruvius goes still further to determine the matter in this way,—as follows:

The height of the Doric column being six times the length of the *foot*, he says this was changed in converting the Doric into the Ionic column, by making the height seven times this length,—and, after that, another change was made in the further conversion into the Corinthian, by making this last column eight times the length of the foot, or diameter; by which we see that he is making use, *seriatim*, of the numbers 6 and 7 and 8 to define the intended or proposed use of  $113 \times 6 = 678$ , in a matter wherein he could not speak plainly.

Third: But while following the precedent already set in the Mosaic books in the narrative of the dove and the raven of the Flood, for Grecian architecture, he does not stop here, but works the column constructively, by these veiled numbers, taken to show the ineffable name of the Hebrew Jehovah. He says, the column should have twenty flutings. From this, the circumference, or 355, is to be divided by 2, (20), which gives a circular value for each fluting of  $\frac{355}{20} = 17.75$ . At Mount Sinai there were 603550 offerings of a *bekah*, apiece, made to construct a house for Jehovah to reside in, in the midst and in the hearts of his people. 100 talents of this sum, or 600000 *bekahs*, were used for the “*sockets of the pillars*,”

and then, there being two bekahs to the shekel, it is said, "of the 1775 shekels remaining, were made the *joinings of the pillars*" of this residence. The measuring *man ratio* of 113 to 355, if multiplied by 5 will give 565 to 1775, or this very number in the last term, of which, as a circumference of a circle 565 is the diameter. But 565 can be placed under its equivalent form of  $56.5 + 10$ ,—and in this last form these numbers read *jod hé vav hē*, or the Hebrew name Jehovah:—and thus we read His name, and actually see Him as residing in the house of a circle as the numerical enunciation of its diameter line. Divide this circle into equal parts ( $355 + 5 = 1775$ ). Join the points of division by right lines and the *blazing star*, or the pentalpha, or seal of Solomon, (C. A. King's Gnostic Gems) will be produced; and this was probably its chief or first symbolic application.

So here, with the Greeks, by use of the same ratio, we find the same results produced by the flutings of the column, on the *man-measure*, for base and height, under the constructive rules of Vitruvius.

Fourth:—This column in its man-measure diameter reads 113, and this at its top as well as bottom. Above the top was the *capital*, with its ornamentation of *volute's*. If one will look into "The Landmarks of Freemasonry," by the Rev. Dr. Oliver, instead of a front view he will find a showing of the corner presentation of such a *capital*, where the ends of the volutes show the representation of the *horns of a ram*; and this was to indicate the sign of Aries in the constellations. The first sign preceding this was Pisces, or The Fishes. The Passover feast of the Hebrews was a movable one within certain fixed limits regulated by the lunar time of weeks and by the sun "entering into the head of the ram," or Aries (Al-Chasari); and this is the Easter feast of the Christians.

These two signs, so controlling through so many ages, were those of Pisces, or the Two Fishes, and Aries; and they have always represented the bursting forth of nature into the new spring of life, or the passing over from the darkness of Egypt or death unto a resurrection from the dead.

Now the sign of the Fishes is of Hebrew origin (Seyffarth says, not only so but that the Hebrew alphabet took its origin in the signs of the constellations). The Hebrew word for *fish* is N U N (our English *Nun*, a female devotee, and shown in the picture of Mary in the

“*Vesica Pisces*”), and the characterizing or small values of the letters of the word read 565 (or the basic values of the name Jehovah, out of Hauvah or Eva, as already given). Two Fishes then, or the sign of that constellation would be 565 multiplied by two, which would be 1130, or denoted by the number 113 (for the use of the cypher may be disregarded); and as seen 113 is read at the top of the column as the diameter thereof. The junction of the top of the column with the base of its *capital* served then to indicate that of the constellar signs Aries and Pisces.

The laws of architectural interpretation of the Grecian temple were borrowed from the Hebrew Biblical source; and the column so perfected read the Semitic story of the Dove and Raven of the Flood,—of the Hebrew Jehovah in His dwelling place, marked by the blazing star as to the joinings of the pillars,—and of the point in the constellations marking the Passover feast and Christian Easter, viz., that between Aries and the Two Fishes. As has already been said, the measure of time used as to this point was and is called the Metonic Cycle.

Seyffarth says that John the Baptist said of Christ, “He must increase but I must decrease;” by which it was signified that John was born on the 24th (22d) of June, while Christ was born on the 24th (22d) of December,—all which shows astronomical allusion to the sun passing the solstices.

The Dove, the Raven, the Fish, and the Man were very ancient Greek symbols. Two Doves from Egypt alighted on the sacred oak of Dodona in Epirus, and by oracular voice established the first theogony for Greece, by giving *names* to the gods. Here it was that Deucalion, the Greek Noah, descended from the ark of the Deluge and made sacrifice to God. His immediate descendant was Helen (or Hellen) the father of Ion, who gave the name of Ioneans, or Doves, to the Greeks. Helen is but a borrowed Grecian use of Hebrew letters, viz., *hê* (5); *lamed* (30 or 3) with a dagesh point to double the letter, and *nun* (50 or 5); which word or name carries in it the small or characterizing numbers 355—while if the *lamed* be doubled by dagesh, the word, or Hellen, will give 565, or the Eva or Jehovah numbers of the Hebrews. The son of Hellen was Ion or Iona, the Hebrew word for *Dove*. While these symbols stood at the source of the Grecian religious philosophy and mystery, they play the initiative part in the Christian. Jesus, the Hebrew word

for *man* and *fire* (the old Greek Iason, *physician* and *healer*), with the Greek suffix, stood in the water up to his head, thus becoming the type of the Fish-man. \*John (Dove) His baptiser said, "and I saw the Holy Spirit descending from Heaven like a Dove (John) and it abode upon him." John (Dove) the Evangelist, a disciple of that other John saw this. So there were three Johns (or Doves) who participated in this scene. See the three triangles on the chair above the head of the W. M. in the F. C. Degree. These are the representatives of the three Johns, or Doves, viz., 71 and 71 and 71, or together 213, the word *Head* in Hebrew *Râsh*, or 35.5×6; the diameter to compare with which is 11.3×6=678. These three Johns are derived from the 3 and 5 and 7 steps that are taken to attain to the presence of the W. M. "*in the East*." The sum of the small values of this *Head* of the W. M. are 2+1+3=6, each of his hands has 5 fingers, together 10,—so that, the representative of 10 and 5 and 6 and 5 in this symbolic picture he sits as Jehovah or Messiah, with the glory of the Doves as the Holy Spirit above him :—and herein was the voice (Bath-Col), audible through the vowels of the Ineffable Name.

---

\*The name John is but a use of the Hebrew word Ion or Ionah, Dove. The words Jonah—Ionah and John are one and the same.





[From the MASONIC REVIEW for September, 1885.]

## THE CABBALAH.

By BRO. J. RALSTON SKINNER (McMillan Lodge, No. 141).

No. I.

It is said in the article on Hebrew Metrology, in the July number of the REVIEW, that the system embracing it was a language, veiled under the Hebrew text of Scripture, and that "to the extent to which the language was known among the Jews, the learning and teaching thereof was called 'CABBALAH.'"

It is a fact that so little is known of Cabbalah that its existence has been denied. It has seemed to possess a like property with that of the existence of Prester John, namely, the more and further he was searched for the less he could be found and the more fabulous he became. After the same fashion, as very much was related of wonders connected with Prester John, so the most marvelous things are claimed for Cabbalah. The Cabalistic field is that in which astrologers, necromancers, black and white magicians, fortune tellers, chiromancers, and all the like, revel and make claims to supernaturalism *ad nauseam*. Claim is also made that it conceals a sublime divine philosophy, which has been attempted to be set forth in a most confused and not understandable way. The Christian, quarrying into its mass of mysticism, claims for it support and authority for that most perplexing of all problems the Holy Trinity, and the portrayed character of Christ. The good, pious, ignorant man picks up Cabbalah at will as a cheap, easy and veritable production, and at once, with the poorest smattering of starved ideas, gives forth to the world, as by authority, a devout jumble of stuff and nonsense. With equal assurance, but more effrontery the knave, in the name of Cabbalah, will sell amulets and charms, tell fortunes, draw horoscopes, and just as readily give specific rules, as in the case of that worthy Dr. Dee, for raising the dead, and actually—the devil.

No wonder then that the whole affair has been discredited and condemned by the rational and the wise.

Discovery has yet to be made of what Cabbalah really consists before any weight or authority can be given to the name. On that discovery will rest the question whether the name should be received as related to matters worthy of rational acknowledgment.

The writer claims that such a discovery has been made, and that



the same embraces rational science of sober and great worth. He claims that it will serve to clear up and away very much of the mysticism which up to this time has been an unexplainable part of religious systems,—especially the Hebrew or Jewish, and the Christian,—so much so that the supernatural in those systems will have to give place to the rational, to a very great extent. He claims that that sublime science upon which Masonry is based is, in fact, the substance of Cabbalah,—which last is the rational basis of the Hebrew text of Holy writ.

As Cabbalah is inseparably connected with the text of the Scriptures, as an exposition of the inner sense of the same, it is proposed, concisely as possible, to set forth a description of that Hebrew text and the history of the Old Testament,—before the Christian Era, and thereafter to the time of the Reformation. And this is to be done to show that what the Reformation really needed to perfect its great promise, and without which it had to be imperfect and incomplete, was the knowledge of Cabbalah as to its real teaching and containment. John Reuchlin did claim at the time that knowledge of the Cabbalah was necessary to a right and full understanding of the Sacred Text. But he saw vaguely, being taught in the same, only in a mystic phraseology which was a blind, and he did not come into possession of solid, rational grounds of the same which he could formulate and impart. For this reason, though he was right in his general assertion, his scheme failed, and his works in this regard, passed away from the common sense world, and have ever since lived only among the mystics and dreamers.

Like all other human productions of the kind, the Hebrew text of the Bible was in characters which could serve as sound signs for syllabic utterance, or for this purpose what are called letters. Now in the first place, these original character signs were also pictures, each one of them; and these pictures of themselves stood for ideas which could be communicated,—much like the original Chinese letters. Gustav Seyffarth shows that the Egyptian hieroglyphics numbered over six hundred picture characters, which embraced the modified use, syllabically, of the original number of letters of the Hebrew alphabet. The characters of the Hebrew text of the Sacred Scroll were divided into classes, in which the characters of each class were interchangeable; whereby one form might be exchanged for another to carry a modified signification, both by letter, and picture and number. Seyffarth shows the modified form of the very

ancient Hebrew alphabet in the old Coptic by this law of interchange of characters. This law of permitted interchange of letters is to be found quite fully set forth in the Hebrew dictionaries, such as Fuerst's and others. Though recognized and largely set forth it is very perplexing and hard to understand, because we have lost the specific use and power of such interchange. In the second place, these characters stood for *numbers*—to be used for numbers as we use specific number signs,—though, also, there is very much to prove that the old Hebrews were in possession of the so-called Arabic numerals, as we have them, from the straight line I to the *zero* character, together making  $1+9=10$ . The order of these number letters run from 1 to 9, then 10 to 90, then 100 and upward. In the third place, it is said, and it seems to be proven, that these characters stood for musical notes; so that for instance, the arrangement of the letters in the first chapter of Genesis, can be rendered musically, or by song. Another law of the Hebrew characters was that only the consonantal signs were characterized,—the vowels were not characterized, but were supplied. If one will try it he will find that a consonant of itself cannot be made vocal without the help of a vowel; therefore it was said that the consonants made the frame work of a word, but to give it life or utterance into the air, so as to impart the thought of the mind, and the feeling of the heart, the vowels had to be supplied. Thus the dead word of consonants became quickened into life by the breathing in of the Holy Spirit, or the vowels.

This being said then

First: The Holy or Sacred Text was written in consonants only, without any vowelizing, or signs of vowels.

Second: The letters were written one after the other at equal distances, without any separation whatever of distinct words, and without any punctuations whatever, such as commas, semi-colons, colons or periods.

It will be seen at once that a various reading of the text might be had in many places, both by differing arrangements of letters, and by a differing supplying of vowels. A very important difference of reading may be instanced in the first line of Genesis. It is made to be read "B'rashith bârâ Elohim," etc., "In the beginning God created the heavens and the earth"; wherein Elohim is a plural nominative to a verb in the third person singular. Nachmides called attention to the fact that the text might suffer the reading,

“B’rash ithbârâ Elohim,” etc. “In the head (source or beginning) created itself (or developed) Gods, the heavens and the earth,”—really a more grammatical rendering.

What the originally and intended right reading was who can tell? It may be surmised, however, that it was made to subserve a co-ordinating, symmetrical and harmonious working of the characters to unfold and develop their various uses;—as sound signs to frame a narrative,—as numbers to develop geometrical shapes and the numerical enunciations of their elements, comparisons and applications,—as pictures to show forth ideas in some accordance with the story told, and finally,—as musical sounds to give an appropriate song to embrace the whole. The whole compass was to embrace rational proofs, through operations in nature, of the existence of that Divine Contriving Willing Cause which we call God. But be this as it may there was no end of effort for thousands of years, by the best trained and most learned men of the Hebrews and Jews, to give and preserve what had to be decided upon by them as the right reading of the Sacred Text. This reading was certainly perfected as we have it, as early as the time of Ezra; and as to the various readings which offered, the present was perfected as the orthodox one,—or that one to be received by the profane vulgar.

It must be known that it is claimed for the Sacred Scroll, that no letter in it has ever been changed, and that even the marginal readings were part of the original text for a varied use thereof, in perfect accord with the object of its writing. Unlike the Christian Gospels, with the Hebrews and Jews, alike, the original text was sacredly precious as to its every and very letter, and had to be thus preserved. To the contrary of this, the Gospels can be changed in their reading to suit the currently changing ideas of what the same should be. The marks to indicate “*right reading*” were after the time of Ezra gradually made public, were called *Massorah*, and finally, edited by Ben Chajim, were published by Bomberg, in Venice, in the fifteenth century.

After this fashion and mode the books of the Old Testament were prepared and read by the Jews long before the time of the Christian era. They were thus accepted at that time; and afterward by the Christian World:—so that, to-day, we accept the record, as thus prepared by the ancient orthodox Jewish and Hebrew Church.

Whatever may have been the Jewish mode of complete interpretation of these books, the Christian Church has taken them *for what they show on their first face*,—and that only. As they may be read orally, so is their fullest meaning to be gathered from the oral reading; and by means of what the sound of the words may convey to the ear the full and complete intendment of meaning is to be had. The Christian Church has never attributed to these books any property beyond this; and herein has existed its great error.

[From the MASONIC REVIEW for November, 1885.]

## THE CABBALAH.

By BRO. J. RALSTON SKINNER (McMillan Lodge, No. 141).

No. II.

The present form of the books of the New Testament has come down to this time with little change, certainly from the beginning of the fourth century. How to account for the modes of construction of the manuscripts selected to compose this form is now, and as far back as known was, a problem. Agreeably to the laws of evidence for historical facts the existence of the blessed man, the Savior, Jesus, the Jew, is to be accepted as true; and it is this truth upon which the whole burden of the Gospels and the remaining books of the New Testament is made to rest. The record of His life is the portraiture of the *perfect man*, the Adam-Cadmon, the Archetypal Man, the express image of God in perfect holiness, our elder brother, friend and helper. From His time commenced the worldly tradition of the incidents of His life. This must have become widely spread, and through a sufficient length of time to cause those incidents to bear a various narration and a various connection. What appears to be singular with regard to this tradition is that so little, if any trace of it was ever derived as of and from the place of its source, Holy Land, and that its first appearance seems to have been clothed in the garb of the Greek language, perhaps of Alexandria, the seat of so much mystic philosophy. The lack of any trace of origin of tradition in the country about Jerusalem, in the language of that country is as strange as though a series of like occurrences had happened in and about London, of constantly growing popular interest for a space of fifty or one hundred years, the sole evidences of which were to be found only in the French language, with not a trace of record in the English.\* But be this as it may the books as we now have them show that they are the results of compilations upon compilations,—that the substance thereof embraced the development of a *system* requiring much

---

\*It was said of Eusebius that the original of the Book of Matthew was written in the Hebrew dialect, and every one translated it as he was able. But there are intrinsic evidences in the book itself that this could not have been the case, which if necessary could be pointed out.

change of circumstances and a considerable lapse of time after the destruction of the Temple. The subject matter being open and plastic there is no certainty as to what extent modification of recital, with even new matter, could have been worked in upon original tradition, during a formative period of from one to two and three hundreds of years when final results were reduced to a fixed and unalterable condition. Critical exegesis of these books touching such matters is very interesting. It is a singular fact that germs for much of the essential part of these books already were contained in the old Grecian theosophy, which in time had been derived from the old Hebrew books,—from whence, again, the New Testament claims its authoritative source

The life of the Blessed Savior, human in fact, but Divine in manifestations of character, is an unequalled and unparalleled one in all human annals and experiences, save one, and because so such a life history must have been through all time beyond the range of possible conception to any genius however exalted, or to any learning of human character however great or deep. The exception is this, viz., that His life record seems to be the combination or aggregate in one individual of a great number of fragmentary descriptions to be found throughout the Old Testament; and indeed, from the books Job, the Psalms, and the Prophets, can be drawn material sufficient to almost duplicate His history. The substance of such a life, *i. e.* the Divine truths taught in it, had to become, through the influence of a Divine source; and the causative thereof is distinctively to be found set forth in the Hebrew books. The parallels of the Old and New Testaments so abound as to embrace most of the substance of the latter,—and its detail to a large extent. He is styled the second Adam; as Noah went down into the Ark and was delivered therefrom, and as Jonah went into the belly of the fish and was rescued alive, so He went under the earth and came forth; as Moses the leader of the hosts through the waters and the wilderness was the precursor of Joshua who, only, could enter the promised land, so John the Baptist was in the wilderness the fore-runner of the second Joshua (for this is Jesus' name); Samson was His prototype as to breaking through the gates of Darkness and entering into the Spring-time life of the resurrection; and He was claimed in a spiritual sense as sitting by right in the seat and on the throne of His father David, in the restored Paradise of the second Eden. It

seems as if the salient features of the whole scope of the Old Testament had been epitomized in Him as a purposed novel mode of their exhibition, and republication in this new dress, for an unaccustomed part of the world.

The lapse of time, after the destruction of the Temple, through which the materials for the books of the New Testament might have undergone change by an insensible progress, or molding transition, to center them about a purposed fixed system,—such a long lapse of time opens these books to the criticisms of the Tubingen school of examination in a number of important regards.

In its teachings the New—may in great part be looked on as a modified form and a development out of the Old Testament. This being said, it is certainly the fact that by the Early Church Fathers the *outward form* was pronounced to be a garment, or cloak, or veil, for an inward hidden sense, a reading between the lines, having an esoteric meaning and intent. This view on the secular establishment of the Church as an arm of the Government, was suppressed. Thus it appears that as there has been assertion of a Cabbalistic mystic interpretation of the Old—among the Jews, so the Christian Early Fathers made like claim for the New Testament.

After Constantine, when the Church was made, as said, an arm of the Imperial Government, all right of private interpretation of the Sacred Text was taken away, and a fixed mode of reception of the same was enforced by the strong hand of the State or temporal power. The books of the Old Testament as prepared by Jewish learning and care, were adopted without question as to right reading. The Church held and enforced as the only acceptable mode of interpretation for the Old and New Testaments, that the visible text orally read conveyed all the meaning, or intent of meaning thereof; and by this the sole value of these books was made by force of Supreme physical authority to consist only in the open letter,—and this state or condition of acceptance and reception continued unquestioned down to the time of the German Reformation.



[From THE MASONIC REVIEW for December, 1885.]

### THE CABBALAH.—No. III.

By Bro. J. RALSTON SKINNER, (McMillan Lodge, No. 141.)

#### THE GERMAN REFORMATION AND JOHN REUCHLIN.

“It is the spirit of some single mind  
Makes that of multitudes take one direction,—  
As roll the waters to the breathing wind,  
Or roams the herd beneath the bull’s direction.”  
—*Barham on the Genius of John Reuchlin.*

The word “*protestant*” has reference to sifting evidence, separating true from false or vicious, and *protesting* against the alliance. This was the office and task of those who set in motion the Reformation in Germany.

Systems of religious government have the Bible as their base, because some element of the kind is necessary to fasten with firm, natural, unyielding hold upon the deepest feelings, hopes and aspirations of the human heart, in perfect purity.

But this done, then, almost always, this base, in alliance with a subtle, corrupted power, is made to sanction abuses of all sorts against common good, right and sense. Such abuses, especially those that arise out of a cultivated superstition, become enlarged on just in the measure of growth of sottishness and ignorance (by cause of that same superstition) of the population on which they are to be worked, without love, or pity, or limit. By a kind of natural process, such resulting condition reacts upon conspirators, reduces them to like low states; so, the current once set in direction, people, and teachers, and rulers, alike, sink into barbarisms of civil and religious life, more or less open, or more or less subtle, almost beyond recall, or even hope of recall. This was about the situation in Germany prior to 1348, the date of establishment of the first German University at Prague;—after which others were founded in the following order: Vienna, 1365; Heidelberg, 1386; Cologne, 1388; Erfurth, 1392; Leipsic, 1409; Rustuk, 1419; Griefswald, 1456; Freiburg, 1457; Treves, 1472; Ingolstadt, 1472; and so on. Nor was the situation much different for the better, in the interval from 1455, the date of the birth of John Reuchlin, to 1517, when Luther posted his ninety protesting propositions on the gates of Wittenberg. For it was one



thing to learn philosophy as it was then taught (poorly enough) and to treat on it, and entirely another thing to criticise a lame theosophy in any open, public way. "Theology had a certain circle beyond which inquiry dared not stir, for freedom of the teachers was limited by the strong arm of the Church and her ministers. \* \* \* Theology had long made philosophy her slave, and she was still enchained when the age in which Reuchlin was born and educated vigorously broke through the shackles." \* It was then, as if to-day, by supreme punishing power, the great geological epochs were made to be published in all books treating thereon, as limited within the space of six natural days, because the Church so interprets the reading of Genesis. In Germany, as elsewhere, at that time, simple truths of Holy Writ had been, by innocent ignorance and cunning deceit, warped and dressed up in false garbs to suit the purposes of power, playing upon a still lower state of ignorance, and a baser superstition; and, as we all know, the attempts at undressing the monster, so as to expose and set free real truths,—however just and equitable, in themselves, however necessary to advancement of humanity in freedom of individual knowledge,—before long, in partially accomplishing this, had to do it through hells of torment, oceans of blood, and convulsions of the nations. And all in and for the name of Christ! It is said "partially," because even after the Reformation the work of exposing truth and eliminating error was not by any means accomplished.

The Reformation, which was a result certain to attend the spread of intelligence, sooner or later, was precipitated upon the world not in and by virtue of itself, as a matter of primary investigation into theological questions, but as an incident, an objective point, worked towards by extraneous causes,—political and social, as well as religious. The country, in the masses of its people, which in England are called "yeomanry," and in this country "farmers" or "planters," but then, as now, "peasants," (a *caste* term for a low-down, degraded class,) was suffering under intolerable oppression of every kind. Little if any care was evinced for this part of community, which, as now, was, at bottom, that producing class on which all others rested for support, but which did not then, as now, in our own

---

\* Much of the substance of this article is taken from Barham's "Life of Reuchlin," and Köstlin's "Luther."

country, make itself felt as the very necessary and almost only intelligent saving bulwark to preserve the purity of government and the liberties of the whole people. This part of community suffered under crying wrongs. The burgher classes, even in the free cities, had little if any representative right in the councils of the nation. They were divided in interests and counsels; and were after all subordinated to the men-at-arms, who lorded it by the strong right hand. The heads of this last class were, the titled nobility, and the ecclesiastics,—removed to an immeasurable distance from the suffering, toiling, human body and heart, which supported them in their high estates. The indications of the extremes to which affairs had reached, were to be found in the “peasant insurrections” repeatedly made during the last half of the fifteenth, and that one arising in the first half of the sixteenth, century, as an outgrowth of the preparing Reformation. “Their grievances were the intolerable and ever-growing burdens laid upon them by the lay and clerical magnates, the taxes of all kinds squeezed from them by every ingenious device (very much as with us now), and the feudal service which they were bound to perform.” The grasping, cheating, robbing, strong or crafty hand was, as usual, at last over-reaching itself in the convulsive movements of outraged humanity. Like the overstrained earth, storm and tempest, and the upheaving earthquake threatened everywhere. Ready to make use of every offering pretext, the occasion of the sale of indulgences to raise means for constructing St. Peter’s, at Rome, by Leo X., was seized upon by intelligent men (especially Luther) to lay bare the jugglery made of things Divine, to humbug, and bamboozle, and oppress in every way. Every incisive blow at miserable false pretence thrilled through the whole people, as a blow does upon a steel bar, as a welcome harbinger of betterment from wrong. That the people at least thought that in Protestantism they had seized on the main solution of their troubles is found from the fact that “Before Protestantism was fifty years old, in spite of all difficulties, ninety per cent. of the population of Germany were protestant.” The Reformation was in a measure prepared for by the teachings of individual men, to some extent known,—but until the time stated, no opportunity had offered for presenting unquestionable truths to an aroused and fired popular hearing. “Individual great men had made immeasurable efforts for the benefit of the coming era of new light, and

many teachers, for instance, Huss and Jerome, of Prague, preceded by Conrad Stickna (1309), Johann Miliez (1374), and Math. v. Janon (1394), who, as deeper theologians, had prepared men's minds, and excited an inclination for better instruction." But that instruction was new, was surprising, and difficult to realize. So much so, that Luther, as to his experience, wrote Spalatin: "I have hitherto, unconsciously, taught everything that Huss taught, and so did John Staupitz; in short, we are all Hussites without knowing it;"—and long before this, in 1473. John Wessel, who was called "the light of the world," had made impression as novel as profound upon the youthful mind of John Reuchlin, eager for the newly offered learning, when he said: "The popes may be mistaken. All human satisfactions are a blasphemy against Christ, who has perfectly reconciled and justified mankind. To God alone pertains the power of granting entire absolution. It is not necessary to confess one's sins to the priests. There is no Purgatory except God himself, who is a consuming fire, purifying from every stain."

So bound, so stultified were the minds of the ablest men, that they received the plainest and simplest truths of freedom only by great effort, and as a surprise, as a shock, and as a trenchant subversive discovery. It resulted, that, after all, the Reformation involved only a partial clearing up of befogging mysteries;—and such only as lay under the very eyes, upon the upper surface of things.

The great preparation came with the "Revival of Learning" in Germany; which traveled that way *from the East*, by way of Italy, after the fall of Constantinople. That fine writer, Mrs. Jamieson, says: "The 15th century was a period perhaps the most remarkable in the whole history of mankind,—distinguished by the most extraordinary mental activity, by rapid improvement in the arts of life, by the first steady advance in philosophical inquiry, by the restoration of classical learning, and by two great events of which the results lie almost beyond the reach of calculation,—the invention of the art of printing, and the discovery of America. \* \* \* The fermenting activity of that century found its results in the extraordinary development of human intelligence in the commencement of the 16th century. We often hear in these days of 'the spirit of the age,' but in that wonderful age, three mighty spirits were stirring society to its depths: the spirit of bold investigation into *truths of*

*all kinds*, which led to the Reformation; the spirit of daring adventure, which led men in search of new worlds, beyond the eastern and western oceans; and the spirit of art through which men soared even to the seventh heaven of invention.”

The revival of art in Italy commenced with Cimabue, in the end of the 13th century, and culminated in the end of the 15th; and with this came the great revival of learning. Leonardo da Vinci was born 1452, John Reuchlin 1455, Michel Angelo 1474, Titian 1477, Albert Durer about the same time, Raphael and Martin Luther 1483, Carreggio 1493. Attendant upon the revival of study of the Hebrew, the Dominican outrages, headed by the grand inquisitor, Hoogstraaten, broke forth in 1509-10. They had their origin in the advice of a Christian Jew, John Pfefferkorn, to obtain an edict from the emperor to destroy all Hebrew literature with the exception of the Sacred Books, or Old Testament. These outrages in the prosecution of this most worthy and catholic enterprise, were breasted and overcome by John Reuchlin, but endured with all malice and bitterness till 1515. They prepared for and ushered in the Reformation;—and the Reformation itself, Martin Luther being its chiefest exponent, took place in 1517.

At fourteen years of age Luther was placed at school at Magdeburg, with the “Null” or “Noll” brethren,—laymen and clergymen. These brethren, otherwise called “Humanists,” were the chief originators of the great movement in Germany, at that time, for promoting intellectual culture, and reviving the treasures of ancient “Roman and Greek Literature,” which opened the mind to a contempt for the old Scholasticism, “or the theological and philosophical School Science of the Middle Ages, a system of thought and instruction, embracing, indeed, the highest questions of knowledge and existence but at the same time not venturing to strike into any independent paths, or to deviate an inch from tradition or dogmas or decrees of the Church.” Luther’s mind was from the start made free by the new classical learning. “It was the Greek and Latin poets, in particular, whose writings stirred the enthusiasm and emulation of the students. For refined expression and learned intercourse, the fluent and elegant Latin language was studied, as given in the works of classical writers. But far more important still was the free movement of thought, and the new world of ideas thus opened up. In proportion as these young disciples (Luther

being one) of antiquity learned to despise the barbarous Latin and insipidity of the monkish Scholastic education and jargon of the day, they began to revolt against Scholasticism, against the dogmas of faith propounded by the Church, and even against the religious opinions of Christendom in general. History shows us the different paths taken, in this respect, by the Humanists; and we shall come across them in another way, during the career of the Reformer (Luther), as having an important influence on the course of the Reformation."

John Reuchlin was at the head of the school of the Humanists. Of him it is said, in D'Aubigné's History of the Reformation: "To the triumph of truth it was before all things necessary that the arms with which she was to conquer should be drawn from the arsenals in which they had been laid aside for ages. Those arms were the sacred writings of the Old and New Testaments. It was necessary to revive in Christendom the love and the study of the sacred Greek and Hebrew literature. The man chosen by Providence of God for this task was named John Reuchlin." Luther's mind was opened, taught and stimulated toward thoughts, aspirations and gleams of light of freedom, preparing him for his course as reformer, through their teachings, Reuchlin being by him recognized as their head. This he fully acknowledges in a letter to Reuchlin himself, as follows:

#### LUTHER TO REUCHLIN.

"God be with thee, brave man. I give thanks for the mercy of God manifested in thee, in that thou has been able to stop the mouths of the blasphemers. Thou, though unconsciously, wert the instrument of the Divine Counsels, greatly desired by all friends of a purer theology. Thou and thy followers had thought to carry on the matter one way, but God turned it another. I always wished to show myself as *one of thine own*, but no opportunity presented itself, yet my prayers and my good wishes were ever with thee. What was then denied to me as thy ally, falls abundantly to my share *as thy successor*, for the fangs of this Behemoth fasten upon me, as if they would wipe out the disgrace which they endured in the quarrel with thee (that of Pfefferkorn, and the Dominican monks, headed by Hoogstraaten, the grand inquisitor). I also resist them, if with far less power of mind, yet with no less confidence than thou didst oppose to them, and whereby thou didst hurl them to the ground. They refuse to fight me, and will not answer, but press on with might and power; but Christ lives,

and I can lose nothing, for I possess nothing. Thy force has no little broken the horns of these beasts. By thee the Lord has brought it about that the tyranny of the Sophists has at last learnt to withstand the true friends of theology more prudently and mildly, and that Germany has begun to breathe again, after having been for so many centuries oppressed, nay, almost annihilated by the school theology. The beginning of better learning could only have been effected by a man of no small gifts, and as God did (if the comparison may be permitted) reduce into dust the greatest of all rocks, our Lord Christ, and afterward from this dust raised so many rocks, so wouldest thou have brought forth but little fruit, if thou hadst not also been killed and trodden into dust, (by the Dominicans,) whence now arise so many defenders of the Holy Scripture. \* \* \* This is the doing of my soul, which is bound to thee, which is intimate with thee, not only by memory, but also by studying thy works. \* \* \* Farewell, rejoice in the Lord, thou, my most honored teacher."

As John Reuchlin was the head and front and substance of the Humanist movement, which was attended by the consequent results of freedom of thought, and also of the Reformation, when the last was forced by the sale of indulgences, he obtained by right the title by which he has since been known,—

#### THE FATHER OF THE GERMAN REFORMATION.

The sum and substance of the Reformation, out of all kinds of opposition, was simply this: to afford to any individual the literal text of the Scriptures, in every language, with perfect freedom to study, comment upon and discover the real, essential meaning of the same, without terror of fanatical persecution for so doing; in which way, and this alone, the real merit of religions could become, as Guizot affirmed it ought to be, commonly acquired and accepted.\*

---

\*Guizot says: "What is the object of religion?—of *any* religion, true or false? It is to *govern the human passions*, the human will. All religion is a restraint, an authority, a government. It comes in the name of a divine law, to subdue, to mortify human nature. It is, then, to human liberty that it directly opposes itself. It is human liberty that resists it, and that it wishes to overcome. This is the grand object of religion, its mission, its hope.

But while it is with human liberty that all religions have to contend, while they aspire to reform the will of man, they have no means by which they can act upon him; they have no moral power over him, but through his own will, his liberty. When they make use of exterior means, when they resort to force, to seduction, in short, make use of means opposed to the free con-

Reuchlin, in his research into the original Hebrew language of the Old Testament, and into the literature pertaining thereto, became acquainted, by instruction, with the especial literature of the Cabalah, as a sacred divine teaching of the Old Testament. This, to the best of his ability, he gave to the learned and Christian world *as an essential part of the new learning and of true theology*; and, therefore, as part and parcel of that Reformation, John Reuchlin was right. The end and perfection of the Reformation could not be attained without reception of the Cabalah. But the time had not then come for its recognition and acceptance, because Reuchlin did not receive the keys for the proper interpretation of the Cabalah, though his instructors may have had them.

In publishing the fact of the existence of the philosophy of the Cabalah, Reuchlin opened up sources and fields for reformation far beyond the narrow confines within which the utmost capacities of Luther were necessarily limited by reason of the narrowness of his knowledge; and it is to these sources and fields that we will now turn our attention.

---

sent of man, they treat him as we treat water, wind, or any power entirely physical,—they fail in their object; they attain not their end; they do not react; they cannot govern the will. Before religions can really accomplish their task, it is necessary that they should be accepted by the free will of man; it is necessary that man should submit, but it must be willingly and freely, and that he still preserve his liberty in the midst of this submission. It is in this that resides the double problem which religions are called upon to resolve.

They have too often mistaken their object. They have regarded liberty as an obstacle and not as a means; they have forgotten the nature of the power to which they address themselves, and have conducted themselves toward the human soul as they would toward a material force. It is this error that has led them to range themselves on the side of power, on the side of despotism, against human liberty; regarding it as an adversary, they have endeavored to subjugate rather than protect it. Had religions but fairly considered their means of operation, had they not suffered themselves to be drawn away by a natural but deceitful bias, they would have seen that liberty is a condition, without which man cannot be morally governed; that religion neither has, nor ought to have, any means of influence not strictly moral. They would have respected the will of man in their attempt to govern it. They have too often forgotten this, and the issue has been that religions, power and liberty have suffered together.

# MASONIC REVIEW



WRIGHTSON & Co.  
Publishers,

CINCINNATI, OHIO,  
13 West Fourth St.

MASONIC JOURNAL, OF LOUISVILLE, KY.

VOL. 64.

CINCINNATI, OHIO, JANUARY, 1886.

No. 6.

## THE CABBALAH.—No. IV.

By Bro. J. RALSTON SKINNER, (McMillan Lodge, No. 141.)

### JOHN REUHLIN AND THE CABBALAH.

John Reuchlin is called by Ginsburg "the renowned scholar and revivor of oriental literature in Europe." It is said that he was led to the study of the Bible by John Wessel, the disciple of Thomas à Kempis, and that Wessel taught him the elements of the Hebrew language. In 1492 he was so far taught in Hebrew by Jekiel Loans, a learned and much respected Jew, that he was able to proceed with out further help; but still, in 1498, in Rome, he took daily lessons of Abdias Sphorno, or Obadiah Jacobson, another learned Jew. His great work, *Linguae Hebraicae Rudimenta*, the result of many years severe labor, first appeared in Pforzheim, in 1506, of which he says: "A work hitherto unheard of, which has cost me the greatest trouble, and a large portion of my fortune." Although he was not the first Hebrew grammarian, because Kimchi Michlol had already prepared a way for him, yet assisted by his work (*de Rud. Hebr.*) "people of all countries, but especially in Germany and Italy, cultivated the language," and the full credit of revival or rather introduction of Hebrew literature was given to Reuchlin. Barham says: "The greatest credit which Reuchlin obtained, and which none shared with him, was from the study of the Hebrew language, first by teaching it, and afterwards by his Hebrew grammar and dictionary. By means of this language he explored a



completely new field in literature, particularly in theology; for, in it also, this study had been unknown for almost a century; it was to be found only among the Jews, and here and there very rarely with individual Christian teachers. If the Greek language was then decried as leading to heresy, it was still worse with Hebrew:—according to what was said by the lovers of darkness, whoever learnt it was sure to become a Jew.”

He opened the way and means for Luther's translations into the vulgar tongue. But his great desire and aim was to afford the means of critical examination as to what the original Hebrew Bible itself did contain as a matter of fact, and of real scholarship; for, as to this, no one could without such helps pronounce; and the Church cared little, as ever, for anything but its then present existing orthodoxy,—nay, any show of awakening curiosity as to what the Hebrew Bible was, or might be, could only meet with disfavor from that highly conservative source.

Ginsburg and others tell us that already Raymond Lully and John Picus de Mirandola had acquired knowledge of the Hebrew and the Caballah. Mirandola studied Hebrew and Cabbalistic theology under Jochanan Aleman, who came to Italy from Constantinople, and—“found that there is more Christianity in the Cabbalah than Judaism; he discovered in it proof for the doctrine of the Trinity, the Incarnation, the Divinity of Christ, the heavenly Jerusalem, the fall of the angels, the order of the angels,” and so on, and so on. “In 1486, when only 24 years old, he published 900 *theses*, which were placarded in Rome, and which he undertook to defend in the presence of all European scholars, whom he invited to the Eternal City, promising to defray their traveling expenses. Among the theses was the following: ‘No science yields greater proof of the Divinity of Christ than magic and the Cabbalah.’”

Through Picus de Mirandola Reuchlin became aware of this phase of Hebrew philosophy or theosophy, as, by a school of the rabbins, a recognized appurtenant to the Hebrew Scriptures. He not only examined into the Cabbalah to satisfy his thirst for facts of literature, but, on investigation, became a convert to the system,—“within two years of beginning to learn the language, published (1494) his *De Verbo Mirifico*, and afterwards (1516) with more mature learning, his *De Arte Cabbalistica*.” And thus the joint efforts of Mirandola and Reuchlin established a field of literature,

the Cabbalah, which has always flourished, and will continue to flourish so long as our civilization shall last.\*

It is interesting and useful to place this great fact, but it is a matter of especially great weight and value that the knowledge of the Cabbalah was sprung upon the world of letters, with, and *as an essential part of* the Reformation itself. Not that the philosophy of the Cabbalah became engrafted into the study and development of Hebrew (and consequently Christian) theosophy;—for, because of lack of knowledge of what the Cabbalah really was, such could not be the case,—but it was entitled so to be, and the assertion of its existence as a real element of Scripture was, even then, so strongly and enduringly made, that, though an unknown quantity except by name, it has ever since stood firmly, and ready to have such claim made good:—with a vitality that has outworn four hundred years of patient waiting.

Of course there was a field of Jewish Cabbalistic literature,—not open, but confined, for the most part, as a kind of sacred mystery, within narrow and restricted limits, even among the Jews them

---

\*Mention ought not to be omitted as to the true standing of Reuchlin compared with that of Luther. It has already been said that the sale of indulgencies offered a pretext for some movement of a people already very much oppressed by wrongs, as much political as otherwise; and Luther became the exponent and leader of that movement, specializing it against Church action. Admitting, for the sake of the argument, that such a sale was an abuse against the people, in the way of getting their money from them without adequate exchange, it is hard to see what legitimate result or inference could be drawn from the fact itself, in any way affecting ultimate questions of theology or theosophy. Luther was led, step by step, to attack the Church itself, and he found there was no stopping place short of that which affected the very foundation of religious government as it was then exercised, viz., the "Authority of the Church" in matters of ecclesiastical discipline. To make the attack successfully, something had to be invented to take the place of such "*authority*," and he found it in the idea of "*faith*," or simple belief,—which, however, for obvious reasons, had to be a common one among the masses in order to keep a compact organization together, viz., the Church itself. A common faith, when based upon a simple abstraction, that is, without the intervention of a true rational process, would imply the ultimate necessity of a teacher, armed with as much influence to enforce such faith, as the Church already had to enforce its authority;—for which reason it is difficult to see in what respect Luther's invention had any essential superiority over that necessity which the Church had arrived at as the result of centuries of experience. In-

selves. It was of the same nature with what is called, to-day, The Speculative Philosophy of Free Masonry, an ever seemingly substantive embodiment out of surrounding shadowy mists and mental fogs, wherein a doubt always exists whether after all there is in the nebulous matter of the mist itself anything from whence substance may congeal; or, it may, for illustration, be compared to the city of King Arthur, before whose gate Gareth, standing, says: "But these my men—(your city moves so wierdly in the mist),—doubt if the King be King at all, or come from Fairy land; and whether this be built by magic, and by fairy kings and queens, or whether there be any city at all, or all a vision." It is necessary to make a brief mention of this literature with its sources; both that these may be known, and that a foundation may be laid for what is proposed to be stated as to the reality of Cabbalah, and its significance.

There is almost no teaching of the Cabbalah in the English language, except an Essay by Christian D. Ginsburg, LL. D., entitled "The Cabbalah, its Doctrines, Development and Literature"—to which the reader is referred for an extended treatise on a subject, as to which Dr. Ginsburg says: "A system of religious philosophy, or

---

deed, with Luther's daring to make an invention about so delicate and vital a matter, chaos sprung forth, with wildness of theories amounting to absolute insanity; until in the midst of it Luther himself was put to his wits end, and placed in despair. Communism even, in its worst form, became rampant as part of the result, and cropped out under the lead of Munzer, at Muhlhausen, and elsewhere. Zwingli had his favorite pet ideas, as did Melancthon, and Luther was put, strange as it may seem, to great perplexity as to the proposed polygamous marriage of Landgrave Philip to Margaret von der Saal, and so on, and so on.

Reuchlin, on the other hand, was an abiding Churchman, or Romanist, and took no stock in Luther's movements. He opened the field of true critical scholarship, and his unfolding of the Cabbalistic philosophy was part of that field, offered for study. It was a legitimate field of scholastic research, and as such it was received with delight by the heads of the Roman Catholic Church. "Aegidius, General of the Eremites, wrote to the holy Augustin, 'that Reuchlin had rendered him, as well as the rest of mankind, happy by his works, which had made known to all a thing hitherto unheard of.'" Philip Beroaldus, the younger, sent him word, "that Pope Leo X. had read his Pythagorean book greedily, as he did all good books; afterwards the Cardinal de Medici had done so, and he himself should soon enjoy it.'" He had laid open a field of inquiry as grateful and fascinating to Church—as to lay-intellects.

more properly, of theosophy, which has not only exercised for hundreds of years an extraordinary influence on the mental development of so shrewd a people as the Jews, but has captivated the minds of some of the greatest thinkers of Christendom in the sixteenth and seventeenth centuries, and which claims the greatest attention of both the philosopher and theologian."

It is faintly claimed that some statements applying to Cabbalah are to be found in the Talmud; but apart from this we have:—(1) The Commentary on the Ten Sephiroth, by R. Azariel ben Manachem (1160--1238), who was a pupil of Isaac the Blind, and master of the celebrated R. Moses Nachmanides, (2) The Book Sohar (Light), or Midrash, Let there be Light, claimed to have been a revelation from God, communicated through R. Simon ben Jochai, A. D. 70-110, to his select disciples. This book has been pronounced by the ablest critics to have been a pseudograph of the thirteenth century,—the composition of Moses de Leon, who lived in Spain; who, by the admission of his wife and daughter, after his death, first published and sold it as the production of R. Simon ben Jochai, and (3) The Book Jetzirah or Book of Creation,—of unknown age and authorship, but mentioned as early as the eleventh century in the Book Chazari, by R. Jehudah Ha Levi,—as the literary sources for the entire system and scope thereof, so far as disclosed. It is from these sources that the entire volume of Cabbalistic literature has had rise and development.

From these sources, and the numberless treatises and expositions thereon, the history of the subject matter and containment of Cabbalah is laid down as follows: It was first taught by God himself to a select company of angels. After the fall the angels taught it to Adam. From Adam it passed to Noah, thence to Abram, the friend of God, who carried it to Egypt. Moses, who was learned in all the wisdom of Egypt, was initiated into it in the land of his birth. He covertly laid down the principles of its doctrines in the first four books of the Pentateuch, but withheld them from Deuteronomy ("this constitutes the former the '*man*' and the latter the '*woman*'"). Moses initiated the seventy elders, and they again passed the sacred and secret doctrine down to the heads (continually imparting the same) of the Church of Israel. David and Solomon were adepts in it. No one dared to write it down till the suppositious Simon ben Jochai, who really lived and taught, as one of



the most celebrated doctors, at the time of the destruction of the second temple; and his teachings are claimed to constitute the Book of Sohar, published, as already said, by Moses de Leon of Valladolid, in Spain. But Ben Jochai, or whoever worked under his name, though he wrote and published, as said, covered the true doctrines by veils, so that no one but an initiate, or, as the saying runs, 'by the gift of God,' could penetrate behind them;—though the veils of the words still plainly held the secret doctrine, to those who could see. The Cabbalah, as an exposition to the Sacred Text of Holy Writ, was claimed to contain the Wisdom of God in every branch and department of His working,—and all terms and descriptions were exhausted to express the ineffable reward to him who might be permitted to penetrate behind the veil, either by initiation or 'by the gift of God;' satiating every function of enjoyment, and affording an indescribable bliss, in the ultimate possession of the Divine conceptions.

More definitely:—The exposition of the system treats of the Impersonal First Cause manifesting within the limits of the finite. "Before he gave any shape to this world, before he produced any form, he was alone, without a form and resemblance to anything else. Who, then, can comprehend him, how he was before the creation, since he was formless? Hence, it is forbidden to represent him by any form, similitude, or even by his sacred name, by a single letter or a single point; and to this, the words, 'Ye saw no manner of similitude on the day the Lord spake unto you' (Deut. iv. 15)—*i. e.*, ye have nor seen anything which you could represent by any form or likeness,—refer" (Sohar 42 b, 43 a, Sec. AB):—And this shows clearly enough that the supposed sacred names of Scripture do not have reference to the Impersonal First Cause, as its essential designations, but rather to its creations. \* \* Then—"The creation, or the universe, is simply the garment of God *woven from the Deity's own substance* (The Impersonal manifesting in the cosmos, in modes to be expressed by the sacred names and otherwise). For although, to reveal himself to us, the Concealed of all the Concealed, sent forth the *Ten Emanations* (the Ten Sephiroth) called the Form of God, Form of the *Heavenly-Man*, yet since even this luminous form was too dazzling for our vision, it had to assume another form, or had to put on another garment which consists of the *universe*. The universe, therefore, or the visible world, is a further expansion of

the Divine Substance, and is called in the Cabbalah, '*the Garment of God.*'" (Sohar i, 2 a)—“The whole universe, however, was incomplete, and did not receive its finishing stroke till *man* was formed, who is the *acme of the creation*, and the macrosocsm uniting in himself the totality of beings,— ‘the Heavenly Adam.’ *i. e.*, the Ten Sephiroth, who emanated from the highest primordial obscurity (The Impersonal First Cause), created the *earthly Adam.*” (Sohar ii, 70 b). This is more definitely expressed in another place, where it says:—“Jehovah (for which stands the letter *jod*, or *j* or *i*) descended on Sinai *in fire*,” the word for which is *a-sh* (שׁ-שׁ, fire). Let the *j*, or *i*, the signature for Jehovah, descend in the midst of this word, and one will have a *ish*, which is the Hebrew word for *man* (אִישׁ, man); thus *man* became out of the *Divine fire* — “Man is both the import and the highest degree of creation, for which reason he was formed on the sixth day. As soon as man was created every thing was complete, including the upper and nether world, for every thing *is comprised in man*. He unites in himself all forms.” (Sohar iii, 48 a)—“But after he created the form of the Heavenly Man, he used it as a chariot (Mercabah) (wheels, circles) wherein to descend, and wishes to be called by this form, which is the sacred name Jehovah.” (Sohar i, 42 b, 43 a, section A B.)

It is to be observed especially, as to the ground work of the Cabbalah, that the first manifestation was in the “*Ten Sephiroth*,” or Emanations, so called, out of which came the “*Heavenly Man*”;—and the human or earth man represented these Ten Sephiroth in himself. “The lower world is made after the pattern of the upper world; everything which exists in the upper world is to be found as it were in a copy on earth; still the whole is one.” (Sohar i, 20 a.)

Thus it is that the compass of the Cabbalah, by Sohar, is idealized in the form of a *man*. This man represented the combination of the Ten Sephiroth, or, as systematically called, *Emanations*, in which as a unity the whole cosmos existed in its segregated detail; and through which all knowledge thereof, physically, psychically and spiritually, was to be had, in passiveness and in activities;—and through which these activities, as of all potencies—as of angels and powers,—had their special existences. These Emanations had names of qualities, as Beauty, Strength, Wisdom, etc., etc., each

name being located upon one of nine parts marked out on the form of the man ; each of which was called a *Sephira*. The totality of the man being taken as *one*, this added to the nine made ten ; and as a number this was the letter *jod*, already spoken of. The locations of these Sephiroth (shown as circles) are united one with another, so that one Emanation may flow into another ; one into all, and all into one ;—and the 22 letters of the alphabet with the 10 vowel sounds, are found therein, or thereby ; and these are called the “*thirty two ways or canals of Wisdom*” ; and as these letters stood also for numbers, there is in this containment every possible mode of expression *by word and number*. The exposition of the Old Testament, especially the Thora, in the secret or esoteric way, is claimed under this statement ;—that is, by numbering the letters of words, and by their permutations and changes of positions ; so that this is one of the functions of the Emanations or Sephiroth ; and a mighty one for disclosing the Wisdom of God.

The Book *Jetzirah* deals especially with these letters and numbers : “*By thirty two paths of secret wisdom, the Eternal, the Lord of Hosts, the God of Israel, the living God, the King of the Universe, the Merciful and Gracious, the High and Exalted God, He who inhabiteth eternity, Glorious and Holy is His name, hath created the world by means of numbers, phonetic language and writing.*”

The Commentary on the Ten Sephiroth, by R. Azariel Ben Menachem, as its name implies, is directly in consonance with the *Sohar*.

As to the Book *Jetzirah*, Dr. Ginsburg says : “*The Book Jetzirah, which the Cabbalists claim is their oldest document, has really nothing in common with the cardinal doctrines of the Cabbalah. There is not a word in it bearing on the En Soph (Impersonal First Cause), the Archetypal Man,*” and so on, and so on. But here the doctor is at fault for this reason :—The word “*Sephiroth*” means “*Numbers,*” and the *Ten Sephiroth* means the Ten Numbers ; and in the Cabbalistic way these are composed out of a geometrical shape. The circle is the first *naught*, but out of this naught develops a straight vertical line, viz., the diameter of this circle. This is the first *One* ; and having a first one, from it comes 2 and 3 and 4 and 5 and 6 and 7 and 8 and 9,—the circle or naught and its diameter one, the embracement of all together, forming the comprehensive *Ten*, or Ten Numbers, Ten Sephiroth, Ten Emanations.

tions, The Heavenly Man, the great Jah, of the ineffable name. Hence the contents of the Book Jetzirah are of the very essence of the other two ; and all are one.

Now, as said, the substance of the Cabbalah is a rendering of the secret doctrine of the Old Testament, and this is not only asserted, but an argument is raised about the matter in the following set terms: "If the Law simply consisted of ordinary expressions and narratives, ex. gr., the words of Esau, Hagar, Laban, the ass of Balaam, or of Balaam himself, why should it be called the Law of Truth, the perfect law, the true witness of God? Each word contains a sublime source, each narrative points not only to the single instance in question, but also to generals." (Sohar iii, 149 b). "Woe be to the son of man who says that the Tora (Pentateuch) contains common sayings and ordinary narratives. \* \* There is the garment that every one can see, but those who have more understanding do not look at the garment but at the body beneath it; while the wisest, the servants of the Heavenly King, those who dwell at Mount Sinai, look at nothing else but the soul (i. e., the secret doctrine), which is the root of all the real Law." Sohar, iii, 152 a).

Now it is a strange thing, that in the quotations made by Dr. Ginsburg in his Essay, can be gleaned a series of data wherewith to arrange a philosophy of Cabbalistic teaching, covered by the names and remarks on the Ten Sephiroth. The "*trick of the thing*" lays plainly before the eyes in its development, and yet is perfectly concealed from unintelligent observation. In other words, the very text is laughing at the worthy doctor, while he is criticising it with an apparent aspect of superiority and authority. The same thing is to be found in the text of Plutarch's Morals, by C. W. King, and in many other texts where the like phenomenal mode is practiced. It in fact is said that the Cabbalah is evolved by "*hints scarcely perceptible*," and the cunning of the concealment is something to admire and laugh at. The description in Sohar of the mode of communication tends to explain what has been said:

"The opinion that the mysteries of the Cabbalah are to be found in the garment of the Pentateuch is still more systematically propounded in the following parable: 'Like a beautiful woman, concealed in the interior of her palace, who when her friend and beloved passes by, opens for a moment a secret window and is seen



by him alone, and then withdraws herself immediately and disappears for a long time, so the doctrine only shows herself to the chosen (i. e., to him who is devoted to her with body and soul); and even to him not always in the same manner. At first she simply beckons at the passer by with her hand, and it generally depends upon his understanding this gentle hint. This is the interpretation known by the name of *râmāz*. Afterwards she approaches him a little closer, lisps him a few words, but her form is still covered with a thick veil, which his looks cannot penetrate. This is the so-called *dārausch*. She then converses with him with her face covered by a thin veil; this is the enigmatic language of the *hāyadah*. After having thus become accustomed to her society, she at last shows herself face to face and entrusts him with the innermost secrets of her heart. This is the secret of the Law, *sāḏ*. He who is thus far initiated in the mysteries of the *Tora* will understand that all these profound secrets are based upon the simply literal sense, and are in harmony with it, and from this literal sense not a single iota is to be taken and nothing is to be added to it.'” (Sohar, ii, 99 )

The foregoing is a very general outlined sketch of the history and containment of “The Cabbalah.” For one so very imperfectly acquainted with the literature on this subject as the writer is,—for its chief part is stored away in the Hebrew, the Aramaic, and the *Lishon Chakamin*, or “Rabbinical Hebrew,” which requires a special study,—it would be foolish presumption for him to think of passing criticism on, either the reported system of the Cabbalah or its authority, as against, or in company with, the skillful adepts in its study, or the keen, cultivated, masterly spirits who have treated on the matter. Nor is such a thought entertained for a moment. But one may have come into the possession of some original mode of clearing the matter up, both for a system and authority for it, without entering on this vexed ground, or even touching upon it. Instead of dwelling upon the Cabbalah, as disclosed or treated on in the manner and by the means, recognized usually, and hereinabove somewhat set forth, let us turn our attention to the Sacred Text itself:—If it can be shown to set forth a like or similar esoteric teaching with that claimed in the written works on the Cabbalah, it will do away with all necessity of any nice, severe learning in this described literature; and will only need, to establish this literature (The Sohar, The Commentary on the Ten Sephiroth, and The Book

- Jetzirah) as completely authentic, a sufficient showing of sameness between the concealed learning of the Sacred Text and the said literature—with the claims made in it. If the Sacred Text can be shown to hold a systematic development of such esoteric tuition, the question will be set at rest; and we will have to admit as a result that the Bible *is* susceptible of a reading entirely novel, and different from that which appears upon its plain face, or, in its open letter.

The attempt will be made to show this to be the fact,—judgment thereon, of course, being left to the reader. The showing should be of interest to the student in Masonry,—for the burden of this secret doctrine, this Cabbalah, is of pure truth and right reason, for it is of geometry with applied proper numbers, of astronomy, and of a *system of measures*, viz., the Masonic Inch, the twenty-four inch guage (*or, the double foot*), the yard, and the mile. These were claimed to be of Divine revelation and impartation; by the possession and use of which, it could be said of Abram:—“Blessed of the Most High God be Abram, *measure* of heaven and earth!”

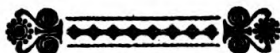



## THE CABBALAH.—No. V.

### MASONIC CABBALAH IN THE BIBLE.

By BRO. J. RALSTON SKINNER (McMillan Lodge, No. 141).

Cabbalah *is* of the essence of Masonry. Its study, therefore, instead of being an abstraction,—mere antiquarian lore, and speculative philosophy, is built from the ground upward, with a practical application to present uses. Our present system of exact science is made up, for its foundations, upon broken, unconnected fragments of this very ancient Cabbalah,—which was claimed to be a complete divine unity, within itself.

For the Mason, therefore, it is necessary, to an intense interest in the development of Cabbalah in the Holy Writ, to preface this work with certain formulations; and as preparatory thereto, an attentive reading of the article on Hebrew Metrology in the July number of this REVIEW, is bespoken. Let me also beg of the reader a careful, contemplative study of the connected statements which will hereinafter be made,—for, “*absque sudore et labore nullum opus perfectum est.*” The key of this disclosed Cabbalistic system rests on the discovered fitness and use of the Imperial British or Masonic Inch, as applied, under Mr. Parker’s discovery, to these ancient unfoldings. This, on first view, is so incredible, that the subterfuge so readily run to, in such matters, of accidental coinci-

Vol. 65.—No. 1.—1.

I

dence, would find ample apology for use here, were it not that the *denominations*, also, of the British measures, based on that inch, are found to be of equal fitting with the inch,—their standard unit. These systems,—of the ancient cubit measures, the old Roman measures, and the present British measures, are found to be coordinately, essentially and intimately interrelated, the one with the other,—in just application — to such a vast extent, that the idea of accidental coincidence is forbidden. Moreover,—it becomes a matter of compulsory, and in the writer's opinion, of overwhelming conviction, viz., that the origin of these systems cannot be, for a moment, ascribed to any artificial primordial human invention,—they must, *ab origine*, have rested in nature itself, and were developed out of nature into human use,—by whatever means, let us say by inspiration, or revelation by the Divine First Power who had created and made use of them;—who also created man, and placed him on this earth, whose (man's) construction and place, in the cosmos, was governed by these very systems of measures. In other words,—the question keeps forcing itself, whether we are not treating of the Divine,—the real essential Divine,—in the Scriptures; that part of them, in which the essential, rational or inductive testimony of the Divine, is to be found in, and in the place of, the “*thing in itself*.” And this is just as it should be; for without this, or some such ingredient in the Holy Scriptures, they must fall to the ground, lame productions as to their divine character and origin. Cabbalah seems to embrace this ingredient. Its development, as disclosed, the writer firmly believes, will, the more it is studied, give satisfaction as to the embracement of this quality; and, thus should be regarded as one of those really marvelous radical discoveries, which once made, must serve for the base of a radically new religious philosophy:—which, once found, must take rank as the substratum of right thought,—that is, of the Holy Temple.

(1.) The ratio of 20612 to 6561, was rediscovered by the late John A. Parker,—as the least and proper integral relation of circumference to diameter of a circle,—while the measuring uses thereof, were, happily and accidently, discovered by the writer. 20612, practicalized as 20.<sup>912</sup> British or Masonic Inches (this inch being the standard unit of measure), *was* an ancient Egyptian cubit:—as already said, the trial measure, microscopically taken, of the very perfect one in the Turin Museum, being 20.<sup>91172</sup> B.

inches. By multiplying part of this ratio (20612) by  $\frac{4}{3}$ , from the product Mr. Parker got a result from whence, as a *measure of time*, he obtained the exact time of a revolution of the moon;—which product, again multiplied by  $\frac{4}{3}$ , gave a result from whence he obtained the exact measure in time of the earth's passage around the sun (with this base, he also discovered a law of the secular variation of the magnetic needle, and other singular cosmic facts). But, in doing this, the other part of this ratio, viz.,  $6561 \times \frac{16}{9}$ , gives 11664; which, strange to say, recovers in 11<sup>664</sup> British or Masonic inches, the exact value of the old Roman Foot! (See researches of John Taylor, and Prof. Greaves, of Oxford).

(2.) Mr. Parker's ratio of 20612 for circumference of a circle, to its diameter of 6561, was based on an *area* computation, as follows:—In a square of 81 to the side, whose area will necessarily be 6561, the area of its inscribed circle will be 5153 (John A. Parker);—and, then, by a true geometrical process, if the numerical value of this area of 6561, be considered to measure the linear length of the diameter of a circle, then, the circumference of that circle will be  $5153 \times 4 = 20612$ :—these elements producing our measuring ratio of 20612 to 6561, as derived from this geometrical truism. Thus, the base of this measuring ratio is 5153 to 6561:—which, let the reader *keep in mind*, as this precise ratio is set forth in the history of Abram, in the Bible.

(3.) Let us now refer, again, to Mr. Parker's process for finding, from 20612 to 6561, the measure of the moon's and earth's times of lunar and annual revolutions. The second product, or  $\frac{20612}{6561} \times \frac{16}{9}$ , is

$$36643.555+ \text{ to } 11664$$

(wherein, 11<sup>664</sup> B. inches is, as said, the old Roman Foot). Now, ask the question: What will be the fourth proportional, in the statement

$$36643.555+ : 11664 :: 11664 : ?$$

The fourth term will be found to be

$$3712.76465+.$$

This is the use of a singularly beautiful proposition in geometry, viz.:—That where a line is dropped from the arc of a semi-circle, on to and perpendicular to its diameter line, such a line will be a *mean proportional* between the segments of the diameter line, so

divided;—therefore, the geometrical diagrammatic display of this proportion will be,—a semi-circle, having a base, or diameter, of 36643.555+3712.76465, or 40356.3202+, with a line, 11664 in length, perpendicular to and touching it, and also touching its arc.

(4.) But this last proportion of

$$11664 : 3712.76465+$$

is a very remarkable one:—For, divide it by 32.4, and the quotient will be

$$360 \text{ circumference, to } 114.5915+, \text{ diameter,}$$

or

360 circumference, to 57.295+, radius of a circle;— which last result is, what is called in geometry, the “*analytical unit of measure*,”—a formulation, laying at the base of plane and spherical trigonometry, the logarithmic tables, surveying, engineering, architecture, etc., etc.

(5.) Divide, however, this 11664 : 3712.76465 by 18, and we will have a quotient of

$$648 : 206.26470+,$$

or we may have the full proportion of

$$206^{12} : 65^{61} :: 648 : 206.26470 :—$$

which brings us to a most significant state of results;—For, whereas, 206<sup>12</sup>, as British (or Masonic) inches, is the recovery of *one* ancient Egyptian cubit measure, 20.626470 is (in fact!) the recovery of *another*, viz., the so-called “Nilometer Cubit,”—the trial restoration of which, by Wilkinson, was

$$20.625 \text{ B. Inches.}$$

(6.) This result, as the development of a measuring system, is nothing less than wonderful, when it is found to involve this further fact, viz.,

$$206264.70+ \text{ seconds}$$

is the *radius seconds* of the circle of 360 *degrees*! And further,—this is the known quantity, selected to enter into the modern equation, by astronomers, to find the angle of parallax, and the sun’s distance.

Hence, from our geometrical base of 206<sup>12</sup>, which as British inches, is 10 Turin (ancient Egyptian) cubits, we develop the fourth term of 206.26470, which is at the same time, *radius seconds*

of the circle of 360 *degrees* (time measure), and, in British or Masonic inches, 10 Nilometer (ancient Egyptian) cubits:—wherein we see we have a *co-ordinating measure* of Space and Time.

(7.) The number 10, the picture of the circle and its diameter line (one), was held as sacred, and in Hebrew was the letter *Jod* or *j* or *i*, the signature of the name Jehovah, by whom all things were created (and the Christ of the New—was the Jehovah of the Old—Testament). The two letters *j* or *i*, and *h*, or the numbers 10 and 5, composed the sacred name, *Jah*, for Jehovah, and together made the number 15. But these especial letters for these numbers, were so sacred that they were not permitted to be used to designate this value,—but other letters were substituted. In the Gospel according to St. John, Christ is called the “*Light*,” and the Light was the Word, or “*Logos*.” Now the Hebrew word *Light* was AOR, which triangular (because tri-literal) word, read on the bound of a circle, as will be shown, gives in numbers, this geometrical, measuring number 20612, which as 206.<sup>12</sup> British, or Masonic inches, was

10 Cubits:—

So that it was expressive of its geometrical and numerical, and measure origin, and at the same time, of its use of this sacred number 10 such cubits. The number 5 (the letter *h*) is its lowest factor; which, with its double, 10, makes the Ineffable Name, *Jah*. The Holy of Holies of the Great Pyramid, of the Tabernacle, and of the Temple with its Porch, was built by the originating factor of this 10 cubits;—and from the architectural were said to proceed, or develope, the “laws and ordinances” of the spiritual house not made with hands. Hence the number 10 cubits, in its original of 206.<sup>12</sup> Masonic inches, was esteemed as the

Sacred Foundation

for all manifestations, or incarnations of the Supreme Being, or Divine Architect;—which for this reason was considered—Most Holy. But because 10 such cubits pointed to the *two* interrelated cubits. viz., 206.<sup>12</sup> (Turin), and 206.<sup>26</sup> (Nilometer) cubits, the number

206,

the, in-common, expression for either or both thereof, was made use of, which would carry in *one word*, this geometrical, numerical, measuring, sacred idea, with reference to both the cubits. This



word was the Hebrew *Dabar*, or, in English, “*Word* ;” and, just as Jehovah became the Christ of the New Testament, so this Hebrew word, “*DaBaR*,” became the Greek “*Logos*,” or as we have it, “*The Word*,” viz.,—that “*Light*” by which all things became :—because the letters of this original word *DaBaR*, or דבַר, signified, in the sum of the values of its letters, R= 200, B= 2, and D= 4, together.

206,

or this 10 Divine cubits ; as derivative from the Light (AOR, or 20612), by which all things were made (—“*which, for us men, and our salvation, came down from heaven, and was made Man*”),—that is to say, again :—the, in-common, designation, in whole numbers, for 10 Turin cubits (206.12 inches) and 10 Nilometer cubits (206.25 inches) ;—so, that, the mysterious use of *DaBaR*, *Logos*, *Word*, lays in the number 206, as expressive of this fundamental fact of measure,—the same fact carrying with it, to one acquainted with the system as said, the familiar knowledge of all the above, with an infinite extension of the same, by way of development, besides. .

The use of this word *DaBaR*, is supplemented by the use of its plural, *DaBaRIM*, in the description of the Ark of the Covenant ;—by which what has been stated is both proven and explained.

(8.) If now we take the whole of this measuring proportion, viz. : 20612 : 6561 : : 64800 : 20626.47001 and multiply it twice by  $\frac{4}{8}$ , or once by  $\frac{1}{2}$ , we will have, as product : (1) The measuring uses, by Mr. Parker, of the times of the moon and the sun, (2) The Roman Foot in British inches, and (3) In the fourth term, the value

36669.2800309+,—

which, as British inches, was, and is, the measure of the length of the four sides of the base, between sockets, of The Great Pyramid of Egypt!—or, reduced to feet,

3055.7733359+,—

or, for each one, of the four base sides of the pyramid, between sockets,

763.9433339+ feet.

(9.) I speak here *by the card*,—because, by the exactest measures between the sockets of the pyramid, taken most carefully by various parties, especially the French engineers under Napoleon, and Col. Howard Vyse, of England, this line was found to be

9168 British Inches,—

while 763 943+ feet, are

9167.32+ British Inches !

In which regard, we may say, in passing, this same measure is justified, over and over again, constructively, throughout the pyramid,—as to which, we will give the following, but one out of many proofs thereof, viz. :—I found, constructively, that the floor line of The Descending Passage Way, into the Pyramid, was just 200 Nilometer cubits, or 2062.6470 British inches, multiplied by 2, or 4125.294 B. Inches ;—

As to which, Col. Vyse, carefully restoring and measuring that line, says :—

“ about 4126 inches ! ”

This is 343.7745+ feet, (but 3437.745+ *minutes*, is the *radius minutes* of the circle of 360 degrees!). Now, to 343.7745+ feet, add its  $\frac{1}{3}$ th, and we will have 343.7745+38 197166+ =

381.97166+ Feet,

or the half base side of the pyramid ;—or multiplied by 2, this gives the product of

763.943339+ Feet,

as above. That is,  $\frac{2}{3}$ ths the length of The Descending Passage Way, is the length of the base side, between sockets. To carry the matter a little further :—34.37745 feet, or 20 Nilometer cubits, is the length of the King's chamber, while the half of this, or 10 cubits, is the width of the King's chamber. These are the measures of the Holy of Holies of the Tabernacle and Temple. We may also add this :—343.7745+ is the diameter of a circle whose circumference is precisely 1080,—and 1080 is the sum, in time measure, of the three great circles of the year day values, viz., 355 the lunar year, 360 the calendar year, and 365 the solar year, or 355+360+365=1080; by which, the conversion into astronomical time measuring use is seen. To which may be added, that with the Jews, their least measure of time, was the division of the hour into 1080 chiliakim or scrupules.

(10.) Now John Taylor discovered that the *height* of the pyramid bore the relation to *twice* the side of its base, as diameter to circumference of a circle. Therefore for a *base side* of 381.971+  $\times 2$ , the *height* of the pyramid proper, would be 486.+ *feet* ; and group with these measures, this further, viz., that the length of this base side

would be 444. + *cubits* (all these being measures, in-common, for construction by either Turin or Nilometer cubits,—their difference, in application, showing in decimal expression). This group of measures is shown in the *names* of the three sons of Noah, as given in Holy Writ;—for place these names, or “Shem, Ham and Japhet,” in Hebrew, as follows:—

ד	ש
ד	ח
	,
ח	פ, —

and then place the characterizing small numbers of the letters of these names in the same relative order and positions, and we have

4	3	
4	8	
	1	
4	8	6

wherein, in the measure of *feet*,—381 is the half *base side*, and 486 is the *height*;—while 444 is the *cubit* measure of the full length of the base side, as said above.

Just as the word DaBaR, or 206. was the, in-common, designation for the two classes of cubits (either of which used carried the other use by intendment or implication), in their strict measure of 206.12 or 206.28 inches, for 10 Turin cubits or 10 Nilometer cubits, respectively, so I find in the Bible, 381 and 763, and other values, are used for a like implication of two connected, contrasted harmonic values, growing out of a common formulating base.

The reason why I have given these pyramid measures is to show a direct connection between them and the Masonic 24 inch gauge, as follows:—Take a circle, or clock face, whose circumference is exactly 24 inches, to indicate the scale of one inch to a hundred feet, its diameter will be

7.639433339+inches;

or, agreeably to the scale,

763.9433339+feet,—

or the exact measure of the base side of the pyramid, from which, as a base, or side of a square, the reproduction of the Egyptian Pyramid can be made by giving it a height proportioned as above, to this base. Hence, one can see the Masonic connection. What

seems to confirm this is, that these measures, as shown, involve the circle of 360 degrees,—but the circle of 360 degrees is also that of 24 hours, represented by the 24 inch guage used for a time measure, that is, one inch to the hour; and the diameter of this is 7.63943+, as said.

(12.) I must note it as a phenomenon of the Biblical measures, that as to the cubits, they are almost always used in the *double*, just as the Holy of Holies is a double cube, and the altars are double cubes. The apparent reason is, that the *double* is always made use of to signify, or follow out, the law of nature in its doubled aspects, or polarities,—as, man and woman, heat and cold, summer and winter, day and night, the sun and moon, etc., etc., as necessities of conflict, or crossing, for production. For, where these circular cubit measures are brought into use, as we will show further on, instead of 20612, they are to be found as 41224, or the *double* of this. There are some exceptions, as for instance,—in the 18th chapter of Genesis and 10th verse, where there is a symbolic picture of Abram and Sarah standing in the door of a tent (a pyramidal structure with a triangular opening) these words occur, as explaining the use of the picture:— $\text{H}' \text{ a h l} - \text{V}' \text{ H u a}$

והוא	האהל
1656	3515 ;

wherein, by the numbers of the letters of the words, we have the direct ratio of 5153 to 6561, given, or the Parker base of this entire system of geometry and measures. In this connection, the fact is exceedingly interesting, that the vertical height of the lip of the floor of the mouth of The Descending Passage Way into the Great Pyramid, above its base, was 51.53 feet;—which measures I also found were made use of in the Ark of the Covenant, as 5.153 feet, and 51.53 inches.

(13.) Thus we have: (1) The geometrical shape of a circle and its diameter line. (2) The numerical relation, or ratio, between that diameter line and the circumference of the circle, which, it is claimed, is the veritable and true integral relation; if for no other reason (and we have other good and sound ones) than because it is to be found as the base of a Divine system of measures in the Holy Bible. (3) This numerical value practicalized as a cubit measure, the standard unit being the precise length of the at present so-called

Imperial British Inch, by which, on application, reconstruction of The Great Egyptian Pyramid can be made so as to recover the architectural intent,—in which is involved the use of the 24 inch gauge ; thus marking the system, as, at the same time, the most ancient, and yet the most modern of the world. (4) The recovery of the source from whence, not only our measures, but a unit system in which this source is contained, which shows us that our present measures are directly connected with geometry,—in the elements of the circle called “*pi*,” the “*analytical unit of measure*,” and the “*circle of 360 degrees*,” with its various uses. (5) And, finally, this system seems to have been one of Divine use, out in the cosmos ; and to have been imparted by The First Intelligent Cause, as his gift, for his creatures uses and purposes.

From this, the whole scheme seems to be Divine in its very essence,—and this is the claim that Masonry makes for *its* foundations ; of like kind, application and import.

It now remains to be seen whether we can find this ratio of 20612 to 6561, used for measuring purposes in the Bible, as giving the cubit of 20.612 inches,—with its correlated one of 20.626470 + inches. If we can, then what I have claimed as to the Cabbalah, must be true.

I will now make a showing of this fact,—which is but partial, after all, and but one of a vast number of Cabbalistic readings of various nature. We know that this cubit value, in Masonic inches, was Egyptian, and if we find it also in the Bible, it but confirms this knowledge.

The first mentioned use of measures in the Bible is to be found in the narrative of the Flood, viz., in the description of the construction of the Ark or Theba.

There is a sort of preface preparatory to the use, in the alleged *distance of time* from Adam to the Flood. For, it is said that from Adam, whose primal location was in the center of the Garden of Eden, to the Flood, was 1656 years. Draw any right line, and write on it these numbers, in their order. They may be read *in the reverse order* as 6561,—and this is permissible by Cabbalah ; by which we have our 6561 diameter to a circumference of 20612. But 20.612 Masonic inches is shown to have been practicalized as one ancient Egyptian cubit ; and here, the geometrical ratio of its origin is seen to be implied in direct connection with the first narrative of

the Bible in which the cubit is made use of as a measure. These numbers are here placed as a *head line*,—as a determinative of the measuring use immediately to follow. For, from this place, commences the development in the text of the Hebrew Bible, of the measures of The Great Pyramid of Egypt. And it must be kept in mind that the learning of the Egyptians was the learning of the old Hebrews; or, rather, the reverse of this. For our present showing, we are to take up in order the three *covenants*, viz., with Noah, with Abram, and that of the Ark of the Covenant at Sinai.

(A.) After Noah leaves the ark, which was constructed in the measures of cubits, God makes a *covenant* with him. He gives him a *token*, or sign, of this covenant, viz., *the rainbow*. The diagrammatic display of this is a *semi-circle*, based on the *plane of the horizon* as its diameter. Thus, this displays the identical geometrical origin from whence, as related, was derived the cubit, in terms of the Masonic inch used as a unit of measure. Both are connected together, viz., the sign or *token*, and the *covenant*, and the terms are so chosen as to interrelate, the one with the other, so as to explain and develop *the purpose* of this covenant. The word *covenant* is *B'rith* (ברית) The characterizing small values of the letters of the words are:  $\aleph=4$ ,  $\iota=1$ ,  $\kappa=2$ , and  $\lambda=2$ , or, in order, 4122. The sum of these small values is  $4+1+2+2=9$ , and 9 is the root of 6561,—because  $9 \times 9=81$ , and  $81 \times 81=6561$ . But place the numbers in order on the bound of a circle, at equal intervals (let the reader try it for himself), and now read the numbers on the intervals of the circle:—We will commence with 4, and read from 4 to 1, from 1 to 2, from 2 to 2, and we now see that we have not covered the last space of the circle, nor can we do so until we have taken again in statement the initial number, or 4; and so, *to complete the spacing of the circle*, we must read 41224. But the token, or sign, was *the half of a circle*, so divide this 41224 by 2, and we have 20612, or the circumference of the circle, whose diameter is 6561; the origin of measures of the cubit, and the old Roman Foot, founded on the Masonic inch. We can now readily see the meaning of the use of the numbers 4122. They are so given that their use will bring out, in numbers, those very comparative elements of the circle, which they are designed to show forth, viz., diameter to circumference; for, their sum is 9, the root of 6561, while read on the bound of a circle, they will natu-

rally be extended to read 41224; which circle so read, will have a radius of 6561;—which, again, is diameter to a circumference of 20612, twice which is this 41224.

(B.) Let us now pass on to the *Covenant* with Abram. From the Flood to the time of Abram's going out of the land of Ur (or AOR, Light) of the Chaldeans, the interval is purposely divided into "from the Flood to Arphaxad 2 years," and from Arphaxad to that time "365 years,"—a total of 367 years. Now 367 reversed is 763, in Masonic feet the length of the base side of the Great Pyramid,—whose pattern is Mount Arrarat, around which these measures are made to play, while 365, in time measure, are the number of days in the solar year. Ararat (אררט for אררת) reads also 4221, as B'rith.

As in the Flood instance, so the narrative of the travels, and so on, of Abram, is prefaced by *head lines*,—expressive of the salient Cabbalistic features of his history. It is said of Abram that he went out of the "Land of the Chaldeans," but the more literal reading is, that he proceeded out of the "*Light* of the Constellations," that is, out of *Light*, for the word for "Land" is

AOR, or Light, that is Ur, Hebrew אור

Now. this word AOR, indicates a triangle, because it is a three letter word. Place a triangle, *point downward*, and place the Hebrew letters of the word, one at each corner, then make a circle pass through the points of the triangle (and you have that geometrical display from whence John A. Parker obtained his numerical elements of the circle, viz., 20612 : 6561, wholly unconscious and unwitting of this further parallel construction and use, for he was no Mason). Then read the *numbers* of these letters, around this circle, as follows:—A is 1, O is 6, and R is 200; begin with 200 and pass on to the 6, that is 206 (DaBaR, *Word*, or 10 cubits), then pass on to the 1, and read 206—1, then to complete the reading of the circle, the 2 of the 200 will have to be read again, making the total reading

20612

again. But take the small, or characterizing values of the letters, viz., 2 and 6 and 1; if we add them together we have  $2+6+1=9$ ; which is the *root* of 6561, the diameter of this circle.

Under this *head line* we will make the display of its use to develop this same system of proportions and cubits. But it is done

with *an advertisement*, to intensify the appreciation of the development, for which let us quote the Biblical title of Abram himself:—The ordinary reading of Genesis, c. 14, v. 19, is, “Blessed be Abram of the Most High God, *possessor* of heaven and earth.” This sentence is of such a construction that the Hebrew word translated “*possessor*,” may be used in apposition with either of the names, “Abram” or “God.” In Hebrew the word is KNH (קנה), which word means *measure*, and in its secondary or more derivative sense *possessor*. The sentence can, therefore, be read, much more literally,—

“Blessed of the Most High God be Abram, *measure* of heaven and earth.”

And, in fact, with the *head line* given, and with this advertisement, the name Abram, with the changes made on it, may be taken as the index of a *system of measures*, having this “*Light*” ratio, of 20612 to 6561, as its base. As said, the original (or Parker) ratio, of 5153 to 6561, is found in the 18th chapter of Genesis, in the 10th verse, in the words—“*in the tent and he*,” or האהל והוא, that is, 5153—6561.

The Lord said to Abram:—“I am the Lord, that brought thee out of the land of the Chaldeans (AOR of the Constellations) to give thee this land to inhabit it.” He promises him a son out of his own loins, but with *a condition*,—of *change* of his name from Abram to Abraham, and the performance of a *covenant* (“between thee and me”), viz., of *circumcision*. This circumcision was “*the token*” of the covenant; and it had this peculiar meaning, viz. :—prior to circumcision, the man was deemed to possess *a feminine* quality, impairing his manhood, which was removed by circumcision. In the affair with the Shechemites, the sons of Jacob say to them in relation to their being uncircumcised,—“for those having the prepuce are women to us,” the word *charaphah*, having a primary signification to which a feminine quality can be attached as the proper meaning in the connection, than the usually translated word “*reproach*.” And Lane, in his notes on the customs of the Arabs of the present day, says of the young lads about to be circumcised, that on the day of the ceremony, and just prior thereto, they are paraded around, dressed in girl’s clothes. (See Source of Measures, page 237).

So, the *token*, or *sign*, of the *covenant* with Abram, was the ring, or



*circle* of the prepuce, which as a feminine mark had to be taken from him, for his new name of *Abraham*, and for his power to become a father; and this token was a *circle* in this case, as was the *circle of the rainbow* with Noah. In both instances, the proceeding had for its object the explanation of the use of the same word, viz., *covenant*, or B'rith, or 4122. Here, as there, the sum of these numbers is 9, the root of 6561, while the same numbers, read on the bound of the circle, or token, will give 41224, or our  $\overline{20612 \times 2}$ .

Refer back to the formula

20612 to 6561 as 64800 to 20626. +

Multiply this by two, and we have

41224 to 13122 as 129600 to 41252.

In the first term of the last proportion we have our *covenant* reading, on a circle, of 41224. But, in this particular instance, the fourth term, or the Nilometer cubit value, multiplied by two, or 41252, *is to be involved* in the change of name of Abram to Abraham;—for which reason, the name or word Abram, itself, must involve the use of the same numbers with the word *covenant*, or B'rith; and they do so,—for the letters of the Hebrew word Abram, are אַבְרָם, and read by their characterizing small numbers, give us 4221. These numbers, in their sum, are 9, the root of 6561,—and read on the bound of a circle are 41224, as were those of the word B'rith. Thus the word Abram is chosen as a synonym, in this sense, with the word B'rith.

Now the word Abraham, אַבְרָהָם has the same letters, with one additional one, with Abram, אַבְרָם. The first name contains the numbers 45221, and the second 4122. But the use of this last, was to indicate the measure of a circle 41224, the first cubit term in the above proportion,—and behold!—we see that in 45221 we have the precise numbers of our fourth term of the same proportion, which reads 41252, with only the difference of arrangement. But this last value is that of *diameter* of a circle, and *is not* to be had by any reading *on a circle*; and this is provided for by the Cabbalistic law of *T'mura*, or change of position of the number letters of a word by *permutation*, as in our arithmetics;—and where a system is shown to be evolving by Cabbalistic development, and the numbers of the letters of a word show themselves to fit precisely as *the proper sequence* of such evolution, we have the right to make such a sequence by the permutations of such num-

bers,—that is, in this case, to support the Turin cubit value 41224 worked on Abram's name, a circumference of a circle value, we can work by permutation the "rearrangement" of 45221 of the name Abraham, to 41252,—the fourth term of the same proportion or Nilometer cubit value, raised on a *diameter* value as seen. As a fact, the *circle* has always been used as a feminine token, while the diameter straight line has, in like manner, been used to indicate the male.

Let us repeat a little. When treating of a subject, in which its parts manifestly refer to a like or common subject matter,—the aim of the use of such parts can be so taken; and there is a law of Cabalah called *T'murah*, or change of the order of letters (numbers) by permutation ("re-arrangement and re-uniting"), by which, if the arrangement will fit in a scheme being elaborated, one has the right to re arrange the numbers of Abraham's name, 45221 to 41252, to suit the manifest and determined intent. You can "halve it and syllable it"; you can "re-arrange and re-unite." Apart from this (parenthetically), the word Abraham may be read as a word, HRM-AB, or *Huram-Ab*, so that by a permitted change of the Hebrew letter *cheth* to *he*, he is the Hiram-Abi of the later books. By this little figure in the Hebrew text, the formation of the Nilometer cubit measure, (viz.,  $\overline{20626 \times 2} = 41252$ , Abraham) is raised from the use of the Turin cubit ( $\overline{20612 \times 2} = 41224$ );—the change being made from a feminine quality, the circle, to a masculine one, the arrow headed diameter line,—a *sharp pointed instrument*. And let us add, in closing this description of the covenant with Abram, the following :

The point from whence Abram sets out on his travel, that is, Ur (—that is, AOR, Light, or 20612), is marked by the 365 years, beginning with the 2 years after Arphaxad, closing on this point as that of his starting out. He travels down to Sichem, שכם, the sum of the values of the letters of which word is 360. And, then, he goes down into Egypt (Darkness) before Pharaoh (פרעה), the sum of the values of the letters of which name is 355. These, respectively, are the days of the *solar*, the *calendar*, and the *lunar* years;—and their sum is 1080, which is circumference of a circle whose diameter is  $343.7745 +$  :—and— $343.7745 +$  feet is, as has already been said, the length of The Descending Passage Way into the Great Egyptian Pyramid (while  $3437.745 +$  minutes, time mea-

sure, is the *radius minutes*, of the circle of 360 degrees), which leads from without, just as does Abram's travel, from the *outer light of the starry constellations*, down past the mouth of the Ascending Passage Way (which leads upward to the door of the Holy of Holies by 3 5 and 7 steps to the three Johns), Sichem, the *shoulder or turn*, down again, into *the blackness of darkness* (that is, Egypt). The measure, in Masonic Inches, of this Passage Way is 200 Nilometer cubits, — 343.7745+feet, or 41252.+ inches, — that is — ABRAHAM. Thus, from Adam to the Flood, to Abram, Abraham, and to Egypt before Pharoah, completes the embracement of the holy territory treated of in the Pentateuch. It would be taking too much space to go very much into detail, but this should be said:—The sum of the values of the letters of Abram's name is  $1+2+200+40=243$ ,—and this is the height of a pyramid whose base side would be 381+. Now 381+ is the, in-common, designation of the half base side of The Great Pyramid, just as the measures are taken from either of our two cubits, and both are always held to each other in connection by intendment. The Great Pyramid was 763 feet for its base side, or 444. cubits,—its half being 381 feet, with height for this last of 243. All which connects these measures, through Abraham, on the one side with "Egypt before Pharoah," and on the other with "*Shem, Ham, and Japhet*" (see *supra*), as also with the 367 (or 763) years from Noah to the point in the Land of AOR (20612); whence Abram started out to go down into the Darkness. And so we might go on, for quantity.

(C.) We may pass now to the *third* covenant, viz., that between the Lord and the people of Israel at Sinai. In this instance, the measures used, and the evidences of their use, are united immediately together in one figure, namely, in the description of the *Ark of the Covenant*, with its contents. The measures of this ark, as given, are: height  $1\frac{1}{2}$  cubits, and width  $1\frac{1}{2}$  cubits, that is, the breadth and height are, each, the half of *three* cubits, and the length  $2\frac{1}{2}$  cubits. In terms of 20.<sup>612</sup> British or Masonic inches to the cubit, 3 cubits are 5.<sup>153</sup> feet, and  $2\frac{1}{2}$  cubits are 51.<sup>53</sup> inches. The word *covenant*, as before, read on a circle, gives us 41224, while the sum of its digit numbers gives us 9, the root of 6561; and this 6561, which is, as said, diameter of a circle whose circumference is 20612, is also the *area* of a square, the area of whose inscribed circle is 5153 (or the numbers of these very measures); so that here, we have refe-

rence back to this geometrical truism. But more than that, we see that we have worked the measures so as to bring out this number, (5153), in *two denominations* of measure, viz., the Inch and the Foot. There is precisely a similar use made of the *coffer* in the King's chamber, or Holy of Holies, of the Great Pyramid. In the tables of measures, by Prof. Piazzzi Smythe, of this coffer, we will find, among others, these measures as given in his pains-taking trials:— outside width 39 inches, inside width 27 inches, inside length 78 inches, outside length 90 inches. The inside depth he gives, by trials, as 34.35+inches, and the outside in depth as 41.2+inches. Make these, respectively,  $34.\overset{37745}{3}+$  and  $41.\overset{252}{2}+$  inches, —and one will find that the construction is so made, by these chosen measures, that the inside cubic contents will be *precisely* one-half the outside cubic contents,—a marvel of constructive work, and one mode of *doubling the cube*. (These are in terms of the Nilometer cubit, whereas, as by the interrelated Turin cubit, these measures, for depths, would be  $34.\overset{353}{3}+$  and  $41.\overset{224}{2}+$  inches). But this is not all; for, the depth 34.37745+inches, is the measure of the length of the room in which the coffer is placed, *in feet*, while the same length is  $412.\overset{52}{5}+$  inches the outside depth of coffer being 41.252 inches in Nilometer cubits—thus bringing out these same denominations. In the *Craftsman*, page 154, will be found:—“The Ark, called the glory of Israel, which was seated in the middle of the holy place under the wings of the Cherubim, was a small chest or coffer, three feet nine inches long, two feet three inches wide, and three feet three inches high,”— that is 45 inches long (the half of 90 inches), 27 inches wide, and 39 inches high:— that is, the same dimensions are given as above for the pyramid coffer, to one who knows how to use the measures; for they are here purposely obscured and disarranged, — they should be 45 inches long (multiplied by 2 to double the cube), 39 inches outside width, and 27 inches inside width, with a supply of the key to the whole matter, viz., the measures of the depths,—which, for obvious reasons, have been omitted. In other Masonic works, the measures of this Ark are given as in the Bible text, showing that *Masonry has both measures*:—and we will now see that both sets flow together in one system.

And now to the Biblical Cabbalistic explanation of these measures of the Ark, as esoterically determined by the context. First,

it is said to be the Ark of the *Covenant*, (B'rith), from whence, as before said, can be had 20612 and 6561. But the matter is more especially particularized in order to make the monumentation exceedingly sacred. There is a *witness*. The ark is called the "Ark of the *Testimony*," and the testimony or, *witness*, was the *Words*, or Ten Commandments, which were placed in the ark. It is called "Aaron B'rith Jehovah," "the Ark of the *Covenant* of Jehovah." But this *covenant*, itself, was the Ten Commandments, or "*Words*," for it is said, in Exodus 24, 28: "And he wrote upon the *Tables* the *Words* of the covenant, the 10 *Words*";—therefore the *Words* stood for, and in place of, the covenant itself,—and the ark was that of the covenant, or *Words*. The Hebrew word for *Words* is

דְּבָרִים, DaBaRIM.

and the characterizing numbers for this word are

41224

in full, or without any supplying whatever. But these words were written upon *two tables of stone*, which signifies division of these words by *two*, just as with the covenant of Noah. So divide, and we have

20612,

or, that cubit value which yields in the given measures of the ark, 51.53 *inches*, and 5.153 *feet*; which 5153 multiplied by four, is 20612. It is by these tables of *stone* that these measures are connected with the proceedings had at Sinai. For the word stone is *abn*, or אֶבֶן, with the digit numbers of 125. There were *two* stones, by which we have the numbers 125, 125. If these numbers are used in the order 251152, this in whole numbers will be the *area* of a square whose *side* will be 5011506 (numbers re-arranged from those of Jehovah coming down on Sinai, or 1056501), which, in whole numbers, is, again, the *diagonal* of a square, whose side is 354.3670548+ or the precise value in the number of days and parts of a day, of the lunar year. That is, twice the square of this year value, is 251152.+;—the square root of which is 5011506, as above. Thus it is that the two tables of stone represent the measure of the lunar year, under the symbol of the stones themselves as containing a mode for the measure of this year. It was the same with the Christian Church, and shown by the phrase: - "Thou art Peter (*stone*) and on this stone (thus twice mentioned) I will build my Church." Therefore, the *Words* were written on *the measure of the lunar year*;—and the words contained the substance of the "Laws and Ordinances;" and the whole was contained in the Ark of the *Covenant*, or 20612 to 6561.

## THE CABBALAH.—No. VI.

---

Let us make digression for the purpose, of enforcing what has been said, of illustration, and of collateral teaching.

As has been said, the wise men who enunciated the Cabbalah dealt first with the fact of a *primal intelligence*, and its creation, or development, the cosmos. This intelligence, they declared, could not be comprehended at all,—could not be located,—could not be named, though the cause of all. They, therefore, designated it by a term of negation, and called it the Ain Soph,—the inscrutable, the unknowable, the unnameable.

Following this, they desired to place, by accurate limitation, *the manifestation* of this Ain Soph, as far as it could be brought within the possible embracement of human thought, or mental grasp. Close your eyes, and from your own consciousness of perception try and think outward to the extremest limits, in every direction. You will find that equal lines or rays of perception extend out evenly in all directions; so that the utmost effort of perception will terminate in *the vault of a sphere*. The limitation of this sphere will, of necessity, be a *great circle*, and the direct rays of thought in any and every direction must be *right line radii* of the circle. This, then, *must* be, humanly speaking, the extremest all-embracing conception of the Ain Soph *manifest*;—which formulates itself as a *geometrical figure*, viz: of a circle, with its elements, of curved circumference and right line diameter divided into radii. Hence, a geometrical



shape is the first recognizable mean of connection between the Ain Soph and the intelligence of man.

But mental perception, to become physical perception, must have the cosmic principle of *Light*:—and, by this, our mental circle must become visible through light; or, for its complete manifestation the circle must be that of physical visibility, or Light itself.

Such conceptions, thus formulated, became the ground-work of the philosophy of the Divine manifesting in the universe.

The first step was to so describe this circle as that it would, in its definition, apply to all circles, to the small as well as to the great;—and this was accomplished by finding a definite measure of proportion, or ratio, between the diameter and the circumference. *in numbers*; which ratio, once found, would be good for all

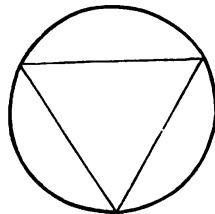

circles. This *ratio* was found through this figure, and was made the basis of all Divine mysteries, including those of the Hebrew Bible, especially the Books of Moses, and those of the Christian New Testament, or Covenant. Our word *mystery*, or *mistry*, is of Hebrew derivation. The word s-t-r, *sâtyr*, means to speak in a veiled way, in or by way of enigma. The hifil participle is mis-t-r, or *mystîr*, “causing to be set forth under a veil or enigma.” This ratio, thus found, was lost to the outer-world;—if, indeed, it was ever given to it,—and now that it has again (by the late John A. Parker) been discovered, Lo! on search, it is to be found most safely and carefully stowed away in the Sacred Records of the Hebrews, as its chief resting place of monumentation.

This ratio was called “Word (cabbalisticé, DBR, *dâbâr*. 206, or 10 cubits) of God (Alhim, or 31415 to 1).” This name of “God” was, in Hebrew, אלהים, whose letters denote the characterizing small numbers, in their order, as 41531; and this number word was selected to annotate one form of this first manifestation of the Ain Soph, in shape and number. For, place these

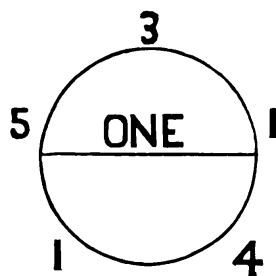

numbers on the bound of the defining circle, as, and it is at once to be seen, that as a “round robin,” they can be read as 31415; (“there shall be One God and his name One”); which reading we recognize as that of the ratio we have been speaking of, brought into prominent notice by use of the shape sought to be defined,

viz : of circumference of that circle whose diameter is *One* :—in all which beside, we recognize the foundation of Geometry, and of our modern higher mathematics,—which, in the *parlance* of the schools, is called Greek  $\pi$ , or *pi*. In Hebrew comments one will find curious remarks on the relative rank of god-names, such as, for instance : The name God (Alhim, Elohim) is not so high and exalted as that of Jehovah, though both are of the same nature. The first is like the Hebrew letters, which are the frame-work for sound or speech, but are dead without the use of the living vowels, or the Spirit, the Bath Col, or Daughter of the Voice. The one is the general law, as it were, while the other is the spiritual use (Al-Chazari). The first is less exalted than the second, and applies more to matter, the latter is the inbreathing of Life. The name Alhim is properly a mode of speech for “*men*,” nobles, princes, etc., while the other is the Divine Spirit actuating the Prophets. This looks like fine-spun metaphysical distinction until the veil is removed from the mystery, and common-sense takes the place. This meaning of “*men*” is made use of to insure, to emphasize and confirm a form of definition. The numbers of *Alhim* are used to secure the geometrical enunciation 31415 to *One*. But not to leave this as a bald postulate, care is taken to make the statement good by a collateral form of expression ; debasing the character of the expression to the word “*Men*.” This word, in Hebrew, is *Anâshim*, אנשים, the characterizing small numbers of which run 41351. Place these numbers on the bound of a circle, in their order, and like *Alhim*, they may be read 31415, or the same with Alhim. Hence the common quality,—and the “*Gods*” are “*Men*” and the men gods, interchangeably ; just as in the Gospel of St. John, God is Light, and Light is God,—that Light “by which all things were made,” so that, Light is very God,—and so on, and so on, to the end of the chapter. God (Alhim, 31415 to One) commanded by his Word (*dabar*, 206, ten cubits) and said Let Light (20612 to 6561) be. Here Either might issue the command to the other, to the same purport and effect. These exalted names are simply made use of to express definitely, so that there may be no room for discussion, man’s possible, proper, conception of the universe in its utmost possibility of embracement, by *shape and number*.

That ratio of this *pi* value, which was so used in the ancient divine mysteries, and was so lost, or never openly given out, was, as said, re-



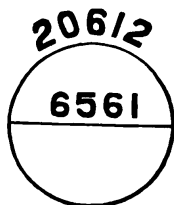
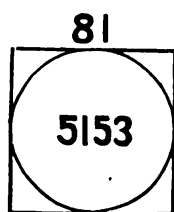

discovered by the late John A. Parker, and it is this: The area of a square whose side is 81, is 6561, and the area of its inscribed circle will be 5153. Now, by a geometrical trueism, such being the fact, if the value of this square area be taken as *the length* of a right line, then, that line will be the diameter of a circle whose circumference will be  $5153 \times 4 = 20612$ , or, by diagram, This is but repetition of that which has been heretofore stated in these articles;—but, as such, it will do no harm,—and, besides, it is now made to open up another field of cabbalistic showing.

As seen, here is a geometrical shape which is the exact sign or token of the extremest possible conception of the manifestation of the First Cause in the Cosmos; and attached to it is the numerical enunciation of the proportional values of the elements of its parts, in definite ratio, viz., 6561 to 5153 and 6561 to  $5153 \times 4 = 20612$ . On this the idea might be, and was conceived, to make use of this fundamental conception to frame on it a *system of measures*,—by giving to each unit of 20612 (the old Romans applied the same unit to 6561) a fixed value by some standard unit of length, which, in fact and in truth, is discovered to have been identically the same with the at present Imperial British, or better, the Masonic Inch;—so that 20612 such inches divided by 1000, should become a to be recognized large measure, viz., that which we call the *cubit*. Certainly nothing could be more symmetrical, of a higher ideal order of invention.

But, suppose attention to have been drawn to this and approval given. It might have been objected that as 20612 was the measure of *a curve*, it would not seem appropriate to apply it or its divisions to the measure of *right lines*,—to satisfy which, and at the same time to construct another system of measures, by a further geometrical process, it was proposed,—that 12 such *inches* should make *one foot*, in a higher denomination. Thus, to at once satisfy the two conditions, it was determined to transfer this value of *a circle*, 20612, onto the edges of *a cube*, a shape fitting to the want, having 12 edges. The result would be to transfer this value onto the edges of the cube, and to make division,

without change of the measure value, thus:—  
That is, the division of 20612 inches by 12, without change or value, would be to convert the *inches* of the *cubit* into the value of *feet*;—thus creating another *denomination* of measure:—and the value of this transfer would be the change of 20612 Imperial British Inches into

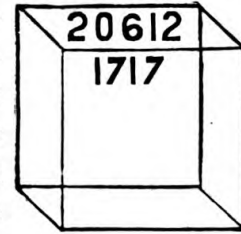

1717 British or Masonic Feet.

With this explanation of process, please observe the steps of shapes and numbers by which this has been accomplished:—

(1.) The *circle*, with its circumscribed *square*, having the ratio for *area* of

5153 to 6561.

(2.) The change from *area* to linear measure, by which 6561 becoming the length of diameter, the circumference of the circle will be 20612, or  $5153 \times 4$ ; thus changing the ratio to

6561 to 20612.



(3.) The transfer of this 20612 onto the 12 edges of a cube, to create a further denomination of measure, of *inches* to *feet* by a division by 12, or

$$20612 \div 12 = 1717 \text{ Feet.}$$

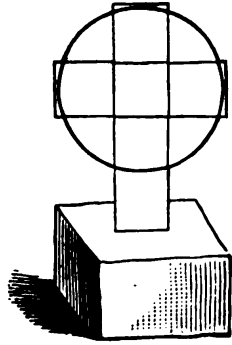
All this having been accomplished, suppose objection was made to *the disclosure* of so magnificent a system to the public,—to the profane vulgar,—and it was determined to preserve the system as a sacred secret to an *Order* and to *initiates*, alone and solely; the Order to embrace the monarch and his school of priests For this, it would be well to blazon the substance of the system by a coat-of-arms for the Order itself,—by some one grand figure which would in close compass set forth the facts and process. For this purpose, to see the whole, the *cube* was blazoned as *unfolded*, with the *circle* attached, as that from whence the cube was derived; the whole to be displayed as standing on a pedestal, that is on the cube to be unfolded by display, as thus:—The cube having six faces (the cabbalistic shape of the Garden of Eden, under the name *Par-dés*—Paradise—which word means *Pārād-samech*, the *division of or by 60 or 6*) is displayed unfolded under the form of a *cross*, to which the circle is attached, which should properly be in (and of itself) a *nimbus*, or glory of light. Place the entire show-



ing upon its pedestal, and we have by blazon, The Cross and Crown on the Rock of Ages, as the grand symbol of this system of cosmic Divine mensuration. The like display is made of the cube of the Garden of Eden,—that “*cubical city*” of the Revelations. That garden grew out of a central germ, viz., a *cubical man*, and the unfolding of this exhibited the blazon of a colossal cross with a man outstretched upon it. Thus, this symbol of the New—was borrowed from the Old—Testament.

With the Egyptians this symbol was given as  or , and by them called *ank* (*I. being, life*) being the same word with the Hebrew *anochi* (the personal pronoun *I*). As  the same was the sign of the goddess Venus. Under another presentation it has been modernized as the Fleur de Lys of the French, and the Irish trefoil. Underneath the geometry and the numbers and the measures was another co-ordinate exposition of the creation of animal life, so that the symbols stood as plainly and instructively for that of procreation as for mensuration, to apply as well to the evolution of man as of the cosmos;—and hence the Egyptian word *ank* was translated into the Greek as *anthropos* or *man*. When the idea of procreation came to be considered, the more general or abstract idea of Alhim (or 31415 to One) had to be brought down to a more definitely vitalizing form. It was found that the *phases of the moon* run so connectedly with the steps of growth of the embryo man, that it became specialized as the intelligent active *cause*. This circle (of the moon) was designated as 113 to 355;—113 being the Hebrew word *man*, and 355 being the Hebrew word for the *lunar year*, or, together, this active intelligent cause. This was the *Shechinah*, that power of Jehovah which made the barren woman to become the joyful mother of children, that holy 7th day and day of the *new moon*, as to the worship of which St. Paul enjoins: “Let no man therefore judge you for such worship.” It was this Jehovistic quality of Light and Alhim, which made the name, יהוה, so above all others endeared, cherished, and adored. This ratio of 113 to 355, called the “*man even Jehovah*” measure, was found to be contained in the name יהוה, and one and the chiefest use of

it numbers was to obtain the exact measure in days (the rising and setting of the sun) of this lunar year.

I have gone thus far into this mode and form of system and symbolization to show and to exemplify a Masonic usage as to the same mystery by one of its (Masonry's), own chosen peculiar modes of monumentation; — which is just as plain as the above when pointed out, though so obscure until attention has been directed to it, that the explanation of the same will most likely afford as much pleased interest and surprised attention, as has been aroused by the preceding articles on this most interesting subject.

#### THE MASONIC APPLICATION.

Many great events in the world's history have been monumented by "*Eras of Time*," and among others the supposed origin of Masonry, by and in that which is called the "*Era of Light*." This is, however, only a symbolical use and style, for Masonry has been accustomed to make use of the current years of other eras, as, for instance, of the Hebrew age of the world, of the Julian period, and of the Christian era, — to, in reality, monument certain salient facts of its occult philosophical or scientific system, while, apparently making use of a year date of an era, as such merely, or as vulgarly made use of. Let us explain this:—

The cycle of Masonry is, as said, called the Era of Light, the symbolism of which has already been referred to, and will be again. This being the case, let us take up a set of *famous traditional dates* in Masonry, — dates which have been largely and fruitlessly discussed, as to the truth of the ostensible tradition.

(1.) The date of the famous charter of Cologne is given as of the year

1535.

As to this, it is said:—"In the document called the Charter of Colne, the following account of the origin of the name of 'Freemasonry' is promulgated:—'It does not appear to us that before the year 1440 the society was known by any other name than that of *John's Brothers*.'"

(2.) It is said by legend, that in the year

1656

"Great Light was shed on Masonry *out of the East* (M—KDM, that is 144—4)."

(3.) A date most fruitful of discussion, even to causing bitterness of feeling, and a sense of injury and wrong to the Order, as belittling its essential worth by claim of such modern invention and origin, has been made—more famous than any other. It is this, viz., “That legitimate Masonry had its origin only as late as the year

1717,

in Great Britain.

Thus, these legends combine, in continuous order, the numbers 1440, 1535, 1656 and 1717.

If one will take up these various dates in the *Light* of symbolic Masonry, to be reënforced and emphasized by multitudes of other evidences of like kind, and in the light already thrown upon the uses of numbers, he will find that the “*Era of Light*” of Masonry, is derived from the Hebrew word AOR (Light), that illuminated province from whence Abram, “the Measure of heaven and earth;” that primordial light of the starry constellations. The symbol is this:—

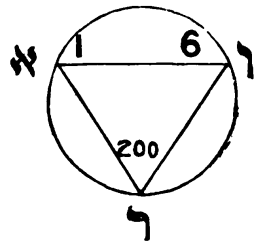

and as measuring a circle circumscribing a triangle, the numbers of the letters of the word serve to display (1) the number 9 ( $1+2+6=9$ ) which is the root of 6561,—and 20612 as read on the circle, as already described.

Such being the case, the dates selected for the promulgation of these legends, are such as contain the salient developments, in continuous order as they take place, of the geometrical foundation of the true philosophy of the Order;—as for example:—

144, is, at the same time, the Hebrew word Adam אדם, or 144, and “*East*,” KDM,\* קדם, or 144. This number is the square of 12, while 1440 is the measure, *in minutes*, of the sun-circle (light) of 24 hours, the measuring token of which is the 24 inch guage: and every 4 minutes of this measure is 15 degrees of the circle of 360 degrees, whose radius is the Nilometer cubit of 20.62647 inches derived from 206264.7 seconds of the radius. (2) The date of 1535 was selected as monumenting the number 5153, the area of a circle whose circumscribed square is 6561 in area, which last is the next date in order. Besides this 1535 is to monument the use of the

\* The Greek *Cadmus* who introduced letters and this sacred learning into Greece.

numbers 135 with the additional 5, as found in the construction of “*The Woman*” (5135) in the Garden, where the number 135 is found to be twice used so as to form the circular expression 531135, by the separation of which numbers the ratio 113 to 355 is to be had *in and by the same figure* with that of 5153 to 6561;—which last use will be found further on in the cabbalistic use of the *Sephiroth*. (3) The date 1656 is the same number with the Biblical space of time from Adam (144) to the Flood and Noah,—and was selected as monumenting the square area, above set forth, containing the circular area of 5153,—while (4) The date 1717 was selected to monument the *transfer of this 20612 onto the edges of a cube*, in such sort, that taken in Britain, as British Inches, this transfer will be reduction from the inches of ancient cubit values to the denomination of British Masonic Feet!

And all this is but a detail use of the symbol Light, or 20612 to 6561. The Hebrew word seems to agree with the Hindu use of the famous word *Aum*, which is characteristically set in a description of splendor or brilliant light.

We thus see that Masonry has a mode, peculiar to itself, of monumenting the land-marks of the same system to be found obscured in the “*Three Covenants*” already set forth. As to the Mosaic books—having thus found such pronounced instances of the use of the Turin and Nilometer cubits,—we can, with this help, find it quite plainly in the Flood picture around Mt. Ararat. From Adam to the Flood, was, as said, 1656 (years,—this word *years* is *shanah*, whose number is 355, showing how easily and yet simply and naturally, the Biblical adepts keep the combination of the two ratios of 355 to 113 and 5153 to 6561, as joined and connected, and yet, in another sense, separated and apart). This number as 6561 is radius of a circle whose circumference is 41224, and this is *Ararat read on a circle*,—while also it is the word DBRIM, Words, 41224, as used about the Ark of the Covenant,—and also in the description of the Sephiroth, to follow. The word is properly אַרְרַת, or 4221 (for אַרְרַט,—the authority for which use can be given), and this value read on the circle gives us the measure of this circle, whose radius is 6561, as the base of this mountain. On this mountain was the Ark, which, as to each of its measures, is but a use of the number 5153:—for, 300 cubits is 5.153 feet multiplied by 100,—50 cubits is 51.53 inches multiplied by 20,—and 30 cubits

is 5.153 feet multiplied by 10, and so on. The extra cubit in which the height was finished, brings out the height above the ground of the opening of the door or passage way into the Great Pyramid of Egypt. This Ark, with the Tabernacle, is again reproduced in Temple construction;—and more, as to its measures, is set forth in the genealogical table from *Adam to Noah*.

COMMENT ON THE SEPHIROTH.

The foundation of the mystic books of the Cabbalah, already spoken of, is made to rest upon the

Ten Sephiroth,

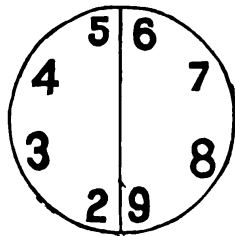

or the 10 Numbers, the picture of which is this: wherein the circle is the *naught*, its vertical diameter line is the first or primal *One*,—from which springs the 2, the 3, and so on to 9, the limit of the digits. This 10 is the first Divine Manifestation, which contains every possible power of

exact expression of proportion,—the sacred *Jod*. By this Cabbalah these Sephiroth were the *numbers* or emanations of the heavenly Light (20612 to 6561), they were the 10 Words, DBRIM, 41224, the light of which they were the flux was the Heavenly man, the Adam-KDM, (the 144—144); and the Light, by the New Testament or Covenant (41224), created God; just as by the Old Testament God (Alhim, 31415) creates Light (20612 to 6561). We find disquisitions as to this Light of various kinds, of which this is one:—There are three kinds of light:—(1) clear and penetrating, that of Jehovah,—(2) reflected light.—and (3) light *in the abstract*. This Light, abstractly taken, (in a metaphysical or symbolic sense) is Alhim (Elohim, God.) while the clear penetrating Light is Jehovah. The light of Alhim belongs to the world in general, in its allness and general fulness, but the light of Jehovah is that pertaining to the chiefest production, man, whom this light penetrated to and made.\* To the fulness of the world in general with its chiefest content, man, the term Elohim-Jehovah applies. In extracts from Sohar, the Rev. Dr. Cassel, to prove that the Cabbalah sets forth the

\* For the penetrating power of light and its effect, see Inman's *Ancient Faiths under Ancient Names*, Vol. 2, page 648. As to the pictures, the author says: "The *vesica piscis*, Mary, and the female emblem, copied from a Rosary of the blessed Virgin Mary, which was printed at Venice, 1542, with a license from the Inquisition, and consequently orthodox."

doctrine of the Trinity, among other things says: "Jehovah is Elohim(Alhim)." At times, he says, "wird das wort יהוה geschrieben, אלהים gelesen. Komm und siehe das Geheimniz des Wortes (Jehovah)! Es sind drei Stufen, deren jede für sich allein in Gott besteht, obgleich alle zusammen nur eine engverbundene, unzerrennbare Einheit bilden." That is,—by *three* steps God, (Alhim) and Jehovah became the same, and though separated, each and together they are of the same One. Now Light, as shown, is 20612 to 6561, as the proper enunciation of the integral numerical relation of diameter to circumference of a circle. God (Alhim, that is 31415 to One, a modified form of the above) is the reduction of this, so as to obtain a standard unite *One*, as the basis, in general, of all calculation and all mensuration. But for the production of animal life, and for especial *time measure*, or the lunar year, that influence which causes conception and embryotic development, the numbers of the Jehovah measure (the "*man even Jehovah*" measure), viz., 113 to 355, have to be specialized. But this last ratio is but a modified form of Light, or 20612 to 6561, as a *pi value*, being only a variation of the same (that is 20612 to 6561 is 31415 to one, and 355 to 113 is 31415 to one, or Alhim or God),—and in such manner that one can be made to flow into and be derived from the other:—and these are the three steps by which the *Unity* and sameness can be shown of the Divine names. That is, the two are but variations of a same ratio, viz., that of *pi*. The object of this comment is to show the same symbolic measuring use for the Cabbalah, as taught, with that of the Three Covenants of the Bible, and with that of Masonry as just noticed.

First, then, the Sephiroth are described as *Light*, that is, they themselves are a function of, indeed, the same as, the manifestation of the Ain Soph; and they are so from the fact that "*Light*" represents the ratio 20612 to 6561, as part of the "Words," DBRIM, 41224, or, as to the Word, Dabar, 206 (=10 cubits). "*Light*" is so much the burden of the Cabbalah as to explaining the Sephiroth, that the most famous book on the Cabbalah is called *Sohar*, or "*Light*." In this we find expressions of this kind: "The Infinite was entirely unknown and diffused no light before the luminous point violently broke through into vision"—"When He first assumed the form (of the crown, or the first Sephira,) He caused 9 splendid lights to emanate from it, which, shining through it, diffused a bright



light in all directions:”—that is, these 9 with his one (which was the origin, as above, of the 9), together, made the 10, that is  $\textcircled{1}$ , or  $\textcircled{\times}$ , or the sacred Ten (numbers, or Sephiroth), or *Jod*,—and these numbers were “*the Light*.” Just as in the Gospel of St. John, God (Alhim, 31415 to one) was that Light (20612 to 6561) by which (Light) all things were made.

The Cabbalistic book, the Sepher Jetzirah, that is the *Number of Creation*, opens with a statement of the hidden wisdom of God (Alhim), in *Sephrim*, (Sephiroth).

“In thirty and two paths, hidden wisdom, established Jah, IHVH, Tzbaoth, Elohi of Israel, Alhim of Life, El of Grace and Mercy,—exalted uplifted Dweller on high, and King of Everlasting, and His name,—Holy! in Three Sephrim, viz.,

B—S’ph-r, V—S’ph-r, V—Siph-o-r.”

This book Sepher Jetzirah, or “*Book*,” or more properly “*Number of Creation*,” is a hieroglyph throughout;—and it is well to understand from the start that the word s-ph-r, is our word “*to cypher* or *cipher*,” to calculate and state by figures or digits. There is a running comment on this particular passage in the Book Al-Chazari, by Jehuda-ha-Levi;—two very excellent translations of which are to be had in the German,—one by Dr. Hartwig Herschfeld, and one by Dr. David Cassel,—the last having the Hebrew, or modern Hebrew text.

This comment sets forth the “*hidden wisdom*” of this original text by hidden wisdom, that is, by the use of words carrying a special set of numbers and a special phraseology, which will set forth the very explanatory system which we find to fit so accurately in the Hebrew Bible and in the legends of Freemasonry. In setting forth his scheme, to enforce it, and to finish out his detailed exposition in a general postulate,—viz., the one word “*Sephrim*” (*Sephiroth*), of the Number Jetzirah, the author explains the separation of this word into three subordinate ones, a play upon a common word *s-ph-r*, or *number*.

The prince Al-Chazari says to the Rabbi: “I wish now that thou wouldst impart to me some of the chiefest or leading principles of *Natural Philosophy*, which, as thou sayst, were in former times worked out by them (the ancient wise ones);”—to which the Rabbi makes answer: “To such principles appertains the Number of Creation of our race-father Abraham” (that is Abram and

Abraham, or numbers 41224 and 41252). He then says that this book or number treats of teaching the “*Alhim-ness* and *One-ness* through (DBRIM)” viz., the numbers of the word “*Words*.” That is, it teaches the use of the ratio 31415 to One, through 41224, which last, in the description of the Ark of the Covenant, was divided into two parts by the *two* tables of stone on which these DBRIM, or 41224, were written or engraved,—or 20612×2. He then comments on these three subordinately used words, and takes care as to one of them to make the comment, “and *Alhim* (31415 to One) said let there be *Light* (20612 to 6561).”

The words as given in the text are—

ספר ספר סיפור

and the Rabbi, in commenting on them, says: “It teaches the *Alhim-ness* (31415) and *One-ness* (the diameter to *Alhim*), through *Words* (DBRIM=41224), by which on the one side there is infinite expression in heterogeneous creations, and on the other a final harmonic tendency to *One-ness*” (which, as every one knows, is the mathematical function of *pi* of the schools, which measures, weighs, and numbers the stars of heaven, and yet resolves them back into the final oneness of the Uni-verse)—“through *Words*. Their final accord perfects itself in that *One-ness* that ordains them, and which consists in

ספר ספר ספור”

that is, the Rabbi, in his first comment, leaves the *jod*, or *i*, out of one of the words, whereas afterward he restores it again. If we take the values of these subordinate words, we find them to be 340, 340 and 346;—together these are 1026, and the division of the general word into these has been to produce these numbers,—which, by T'mura, may be changed in various ways, for various purposes. One of these purposes is this:—the division of 1026 into halves, will give 513—513, which as 531 135, refers to the ratio 113 to 335, and to the origin or setting forth of this measure in the Garden of Eden. If the numbers be arranged as 1206, they can be read on a circle as 20612, which is a factor of the number of “*Words*,” DBRIM, or 41224, and as pointing to which this especial arrangement has been made. So “*the words*” under DBR-I as 206 and 1, which the Rabbi makes use of, exhibit the same numbers; and finally these numbers as 200 and 6 and 1 give us AOR, or that *Light*, again. But this word s-ph-o-r, or si-ph-o-r, is either

346 or 356, and as the Rabbi uses certain articles with the others, as H-s-ph-r making the same 345, we may see here that he is including a further or more ultimate teaching of his system, viz., in the values of the lunar (354) and the two kinds of solar (364 and 365) year, in days. As to the custom or use of *permutation*: in one place the Rabbi says: "Daraus ergibt sich, dass die körperliche Welt in einer Weise, welche dem Körperlichen entsprochen hat, durch der erhabenen geistigen Namen erschaffen wurde, der dem Körperlichen Namen Jhv, Jvh, Hvj, Hjv, Vjh, Vhj entspricht, aus deren jedem eine der Richtungen der Welt entstehen musste—es erstand die Sphäre." These are the letters Jod, hé, vav, or numbers 1065 of Jehovah's name, which as 1056, form the key to the descent on Sinai, and divided by 2 yield 528, the base in *feet* of the extreme of the British long measures and land measures,—for  $528 \times 10$  feet is one mile, and 8.25 feet is the half of one rod (in which the value is reversed as  $\cdot 528$  and 825); and an area of 5280 feet by 8.25 feet is *one acre*,—640 of which ( $320 \times 2$ ) is one square mile.\* As to the subject in hand, the Rabbi says: "Under s'ph-r is to be understood,—*calculation* and *weighing* of the created bodies. For the *calculation*, by means of which a body must be constructed in harmony or symmetry, by which it must be in construction rightly arranged and made to correspond to the object in design, consists at last in *number, extension, mass, weight*;—co ordinate relation of movements, then harmony of music, must consist altogether *by number*, that is s'ph-r. \* \* By Sippor (s'phor) is to be understood the words of Alhim (206—1 of 31415 to one), whereunto joins or adapts itself the design to the frame or form of construction; for example,—it was said 'Let Light be.' The work became as the *words* were spoken, that is, as the numbers of the work came forth. There is also s'ph-r, that is the *Writ*. The Writ of God, however, are his creations, the Word of God is his Writ, the Will of God is his Word."

By all this, there is manifestly to be gathered a peculiar setting forth of the system which we have shown develops in the Hebrew Bible and in Masonry.

#### COMMENTS ON THE MOON AND ITS PHASES.

In trying to get a clear insight into matters of antiquarian lore some very simple rules governing investigation are to be observed.

---

\* This mile measure has a very prominent embracing place in the Great Pyramid, and includes a co-ordinating *time-measure*.

Among these there may be stated :—(1) There was no mystery that had not at bottom some rational ground, probably quite simple, in place of being far off, and (2) A past age may have had familiar usages of thought and speculation which now, for the most part, have passed away.

One ancient usage was the observance of *times*, and this involved *astronomy*,—which we cultivate in a much modified form, and *astrology*,—which we have passed over as a proper vocation of charlatans,—inconsiderately, perhaps, giving it no credit. We are barely out of the time, not much over one hundred years, when astrology was an accepted science, receiving the countenance of the wisest, best, and most learned men. Now, if being orthodox, we refer to our Bible we find that Daniel, the most wonderful of all the prophets, told off God's providence by *set times*, and that the Book of Revelations works by set times, and speaks of a carefully measured *cubical* city descending out of the heavens. We will find that the *stars of heaven* fought for Sisera, that the sun and the moon and the planets were set in the expanse for *signs* and for seasons, and that the sun and the moon and the eleven stars made obeisance to Joseph the son of Jacob. By most ancient records, we will find that in the, then, far-past, the heavens had been mapped with a most singular mode of configuration, and made alive with animal forms, that the great circle of the heavens had been divided by the signs of the Zodiac,—a living belt,—as to which, it is averred, the tokens thereof were the character signs from whence the first alphabet,—and that a Semitic one (Seyffarth). This heavenly life bore down upon, and impressed itself upon all, to the least, lite on earth, and governed its growth and fixed its quality of condition. The compartments of the Zodiac were the Sons of God,—the B'nai Alhim. The powers of the angels of God resided there, as in mansions, and one of such powers would have been sooner with Daniel, “but the prince (of the air) of the kingdom of Persia withstood me one-and-twenty days” But the vitalizing power of heaven lay chiefly with *the moon*, and with all people this satellite was held in honor to a degree. In its vitalizing aspect, it was the Hebrew *יהוה*,—and St. Paul enjoins :—“Let no man judge you for your observance of the 7th day and the day of *new moon*,—*which are a shadow of things to come* ; but the body (or substance) is of Christ,” *i. e.*, Jehovah, — that function of this power that “made the

barren woman the joyful mother of children," — "for they are the gift of Jehovah,"—and which is "the desire of women": — which is a key to the objection which her husband made to the Shunamite as to her going to the man of God:—"for it is neither the 7th day nor the day of *new moon*." The living spiritual powers of the constellations had mighty wars marked by the movements and positions of the stars and planets, and especially as the result of the conjunction of the moon, earth and sun. Bentley comments on the Hindu "war between the gods and giants," as marked by the eclipse of the sun at the ascending node of the moon, 945 B. C., at which time was born, or produced from the sea, SRI (Sarai, S-r-i, the wife of the Hebrew Abram), who was the Venus-Aphroditus of the Westerns, emblem "of the luni-solar year, or the moon, the goddess of increase." By configuration the picture of this war, or the aspects of the stars, was "that all the planets, except Saturn, were on the same side of the heavens with the sun and moon." He says this was the same with the "war of the Titans by Hesiod;"—and by Drummond, the war of the kings in the vale of Siddim with Abraham, was of a like character;—who also says that the Ark of the Covenant was a like "symbol with the Tabernacle and the Temple," all being types "of the venerable system (of astronomy) of which Moses, who was learned in all the wisdom of the Egyptians, seems to have had a very distinct notion."

So, with the ancients, the starry heavens were living spiritual influences,—and the times of the sun, moon and planets, marked their especial aspects, favorable or unfavorable. But the phases of the moon, and her orbital periods of 7 days, 126 days (our Light numbers applied to birth), 210 and 280 days, had especial co-ordination with the steps of embryotic evolution, for which reason the *time of the moon* and the moon itself was worshiped and solicited as the guardian genius for the perpetuation and increase of the human race,—and also became the sacred basis for the computation of solar periods. Starting out with the new moon, viz., conjunction, or marriage with the sun, the natural cycle was their coming together again in the same place in the heavens, which would happen in 19 tropical years of the sun and 235 revolutions of the moon. As I will show hereafter, the grand monument and land-mark of the exact period of the lunar year and month, by which this cycle

could be calculated, was Mount Sinai,—the Lord Jehovah coming down thereon. And this kind of time, being then and there fixed, the regulation of the Hebrew Church as to *observations of time*, such as the Passover (the Christian Easter) and so on, was based on this especial lunar period and cycle. As to this very fact, that wonderful, grand, and good man, St. Paul, speaks as a mystagogue, when he says concerning the freed woman and bond woman of Abraham:—“For this Hagar (the bond woman of Abraham) is Mount Sinai in Arabia.” How could a woman be a mountain? and such a mountain! Yet, in one sense, she was, and in a very marvelously true one. Her name was Hagar, Hebrew **הַגָּר**, whose numbers read 235, or in exact measure, the very number of lunar months to equal 19 tropical years to complete this cycle, and make the likeness and similitude good; Mount Sinai being in the esoteric language of this wisdom, the monument of the exact time of the lunar year and month, by which this spiritual vitalizing cycle could be computed,—and which mountain, indeed, was called (Fuerst) “the Mountain of the Moon (Sin).” So, also, Sarai (SRI) the wife of Abram could have no child until her name was changed to Sarah, **שָׂרָה**, giving to her the property of this lunar influence;—for these numbers afford 532, which is the great lunar cycle in years, afterwards called the Easter-cycle or Dionysian-period, and 235, which is the measure of this fructifying influence in its lower or 19 year cycle.

It is the Church proper that still preserves to itself the substance of this astronomical system as the ground work of her ritual, *out of which* develops the “*laws and ordinances*,” as they did with the Israelites from the 10 Words, Numbers, or Sephiroth, on the *two tables of stone*, contained in the Ark of the Covenant. It is the lack of this feature that characterizes all sectarian denominations as incomplete, unfinished, ephemeral,—being subject to change and disappearance;—they have no bottom to stand on. If one will look at the Parliament Scrolls of Great Britain, holding the original of the Book of Common Prayer, he will find that the almanac is as much a Divine part of the same as the oral service. What is strange about the matter, however, is, that the course of the sun through his signs was erased from the parliamentary constituted religious code, leaving the procedure of the moon only and alone. Look in the preface of any Book of Common Prayer, and the tables

for finding the times of the Church service will be seen to have the lunar phases as their base. Let us give the explanation of this cycle. Ferguson, in his fine astronomy (because of his simple and plain mode of statement) says: "The cycle of the sun is a revolution of 28 years (founded on the week) in which time the days of the months return again to the same days of the week; the sun's place to the same signs and degrees of the ecliptic on the same months and days, so as not to differ one degree in 100 years. The *cycle of the moon*, commonly called 'The Golden Numbers,' is a revolution of 19 years; in which time the conjunctions, oppositions, and other aspects of the moon are within an hour-and-a-half of being the same as they were the same day of the month 19 years before. The year of our Savior's birth (that is, the year 0) according to the vulgar era, was the ninth of the solar cycle; and *the first year* of the lunar cycle. The *cycle of Easter*, also called the Dionysian Period, is a revolution of 532 years, found by multiplying the solar cycle 28 by the lunar cycle 19. This is for predicting what is called Easter Sunday (and could have been used for finding the Passover). By it the earliest Easter possible is the 22d of March, the latest the 25th of April. The first seven (7) letters of the alphabet are commonly placed in the annual almanac to show on *what days of the week* the days of the months fall throughout the year. And because one of the 7 letters must necessarily stand against *Sunday*, it is printed in a capital form and called the 'Dominical letter,' and so on. The measure is on trial so accurate, that by the correlative calculation of the lunar periods to close 1881 full years, for 99 periods of 19 years each, and 99 periods of 235 lunar months each, the close struck the actual observed fact of *new moon*, on the eve of the 31st day of December, (Friday evening) 1880, the eve before Saturday, the beginning of the Jewish Sabbath, the beginning of a new cycle starting out with New Year and New Moon, New Easter cycle, and a New Age; all which times, secular and Divine, for the first time within the knowledge of man *start out alike* in the signs of the Zodiac. Bishop Brownell, in his Commentary on The Common Prayer, says that the Christian tables for times were taken from the Pagan observances,—which, again, were intermediate, and borrowed, as all their learning, from the Semites. Brownell says:—"The Churches of Asia kept their Easter upon the same day on which the Jews celebrated their Passover, viz., on the 14th day of their month Nisan (which month be-

gan at the *new moon* next to the vernal equinox). This finally became a reproach in the Church, and Constantine " (born in the city of York, in commemoration of which the York Rite in Masonry) " procured a canon to be passed at the Great Council of Nice (year 235 ?) that Easter should be observed not on the day of the Jewish Passover, but upon the Sunday following. Also, the following paschal canons: (1) That the 21st day of March shall be accounted the vernal equinox, (2) That the Full Moon happening upon, or next after the 21st of March, shall be taken for the full moon of Nisan, (3) That the Lord's day, next following that full moon, be Easter day, and, finally, (4) But if full moon happen upon Sunday, Easter day shall be the Sunday after."\*

So great was the care to make the *Times* and the "*Laws and Ordinances*" run together or coalesce in observance.

All this pertains to and is a part of Cabbalah.

---

\* Seyffarth says as to the 14th Nisan (the lunar Nisan), that the Jews had also a civil, solar year, in which was a solar month Nisan. In general terms he is supported in this statement by the book Al-Chazari. He says that by the civil calendar, the 14th Nisan was our 19th Julian March. Which shows how astronomy and astrology enter into the Christian scheme of symbolizing. For counting from the 19th March 12 days, then 30, 31, 30, 31, 31, 30, 31, 30, for the following months, to December, then 24 days to the eve of December 25th, or Christ-birth, we have 280 days;—the period settled on by the highest medical authorities as that of gestation. Therefore, this 19th March (or Jewish 14th Nisan, Passover and crucifixion) commemorated *the date of conception* in the womb as well as of death. But, December 24th being the date of the *true winter solstice*, from March 19th adding three days brought the count to the period of astronomical *equinox*;—which shows emphatically the astronomical reason for the use of these three days. The 24th of December is that day on which by true solar movement we have the *end* of one and *birth* of another year, as that (following the Sun life) on which Christ was born. It is little thought of that owing to the eccentricity and obliquity of the earth's orbit, the true solstices and equinoxes do not fall with those astronomically named, the nearest being December 24th;—the others vary as far as to April 15th for equinox, June 14th summer solstice, and September 1 for fall equinox. (See Loomis' Treatise on Astronomy, 1874, page 72,—and also the *alema* on the ordinary terrestrial globes.





(7)

[From the MASONIC REVIEW for September, 1886.]

[From the Journal of The Cincinnati Society of Natural History, July, 1886.]

## **The Identification of the British Inch as the Unit of Measure of the Mound Builders of the Ohio Valley.**

Paper Contributed by J. RALSTON SKINNER, Dec. 1, 1885, to The Cincinnati Society of Natural History.

Very fortunate conditions seem to make the identification of the *unit of measure* of the Mound Builders of the Ohio Valley both simple and easy of demonstration. One may go further, and say *certain* of demonstration, because certainty rests upon but two matters of fact, which, on examination, will probably be pronounced established.

The first of these facts is this: That the measures of a great number of these mounds in the river valleys, and on the river terraces of the State of Ohio, as reported by E. G. Squier and E. H. Davis in their great and now somewhat famous work, "Ancient Monuments of the Mississippi Valley," published by the Smithsonian Institution in the year 1848, are to be relied on. It is but fair to say that they are reliable; both from the reiterated statements of these gentlemen and because the Smithsonian Institution gave the work place in its archives. Independently of these considerations the reported measures of these gentlemen contain intrinsic evidence that they were correctly taken, so strong, that we may adopt them as established data for the purposes of our investigation. When this evidence is coupled with (1) the character of the men reporting the measures, (2) the fact that their labors were approved of by and confirmed by Col. Charles Whittlesey, Topographical Engineer of the State of Ohio, whose surveys of these mounds were made officially, under an act of the State of Ohio, for geological and topographical surveys, and contributed as part of the work of these gentlemen, after they had, as to many, verified and confirmed them, and (3) the acceptance and approval of the institution named, it seems but reasonable to accept it as decisive of the matter. This intrinsic evidence will be quite elaborately given, with a number of quotations as to the character of the surveys, and as to the impressions of the surveyors, taken here and there from their descriptions.

The second of these facts is as follows: The key to this matter is a *stone measure* now in possession of The Cincinnati Society of Natural History. This stone was found in and dug out of the Sixth and Mound street mound in the City of Cincinnati at the

time of its removal, by Mr. C. P. Gridley, now of the City of Springfield, Ohio. He deposited it in the collection of The Western Academy of Natural Sciences, where it was labeled as contributed by him; the original label being now on the stone. The collection of The Western Academy of Natural Sciences, this stone being part of it, passed into the possession of the present society. This is fully verified by the statement of Mr. Gridley himself made to Dr. H. H. Hill, an officer of this society, December 5th, 1878, on the occasion of his (Mr. Gridley) coming to this city (Cincinnati) for the purpose of obtaining this stone. The statement is so important that it is made a part of this paper in Appendix A. The elliptical mound in which this stone was found is the same in which was recovered the "*Gest Tablet*" as to which so much has been said and written. (See Appendix C.)

The writer of this paper, while making investigation into the origin of our British measures, was amazed at the ancient universal use of like architectural symbols all over the world in all lands. Very especially at the almost identity of geometrical display of the Mound Builder's remains with that of the old Egyptian and Hebrews. While examining into this matter in the works of Squier and Davis, spoken of, he was astonished to find that the reported measures given in British feet were such in numbers that a system was disclosed in the general construction, which system could not have been disclosed had any other unit of measure than the British inch been used. So impressed was he with the fact, and yet so impossible did it seem, that in a work, entitled "Source of Measures," published in the year 1875, he made the following remark: "Mounds showing British measures. In searching in the works of Squier and Davis a great number of measures were found, and it was very observable that the English measures seemed so fitting that it was difficult to free the mind from dwelling on their use in the original construction. These measures seemed to be multiples of 3, 4, 6 and 12, and kept running toward the value 360. These facts were noted at the time as curious; but any possible connection seemed, even as it does now, but a wild freak of the imagination, and the matter, though noted, was dropped"

It happened fortunately, that Mr. R. B. Moore, a member of The Cincinnati Society of Natural History, and former President thereof, became interested in the various discoveries set forth in the

works of the writer as to the origin and ancient use of the British measures ; as also in the suggestion of their use in the construction of the Mound Builder remains. Having his attention turned that way, it occurred to him to take the measure of the Gridley stone, the outlines of which are here given :

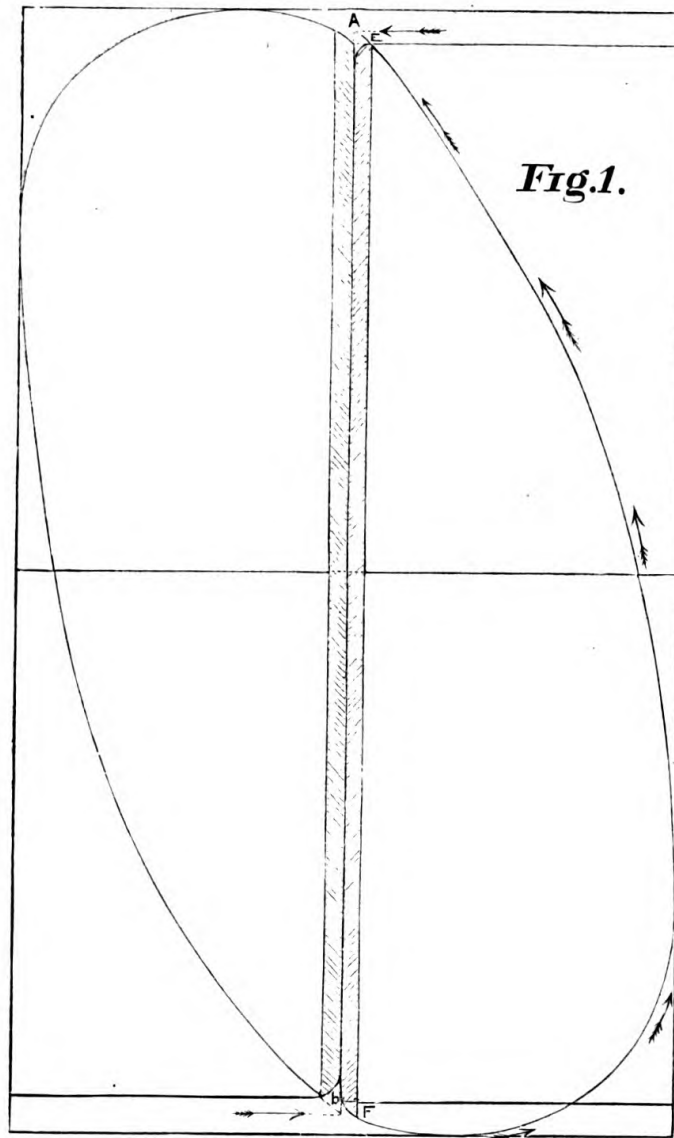

Fig. 1. Around the curve from  $b$  to  $A$  is 12 standard inches. The right line of the face from  $A$  to  $b$  is 9 inches. From  $E$  to  $F$  an unbroken right line is also 9 inches. The figure is reduced *one-half* from an exact *fac-simile*.

As seen it is the symmetrical half of a nearly perfectly proportioned ellipse, the straight edge or line being the diameter there-

of. On measuring the straight edge, or diameter line, Mr. Moore found it to be precisely nine (9) standard inches, and on measuring the curved edge, or half circumference of the ellipse, he found it to be exactly twelve (12) inches. That is, the measure was that of a folded "*two-foot rule*," but in such form of presentation that the foot, or 12 inches, inseparably connected itself with the measure of 9 inches. The extreme ingenuity of the device certainly does honor to the Mound Builders, for  $9 \times 12 = 108$ , while  $9 + 12 = 21$ , five times which is 105, and these two are the typical or key numbers of measures used in the construction of the great and most prominent works in the valley. In addition to this  $108 + 105 = 213$ , which is a circumference value of a circle whose diameter is 67.8, the  $\pi$  ratio being 355 to 113, to be found in the Dunlap works. So also  $9 \times 32 = 288$ , the number of the measure of that particular circle at Newark, on which Squier and Davis lay especial stress. This combination of measures, as will be seen, is used throughout the Ohio works, whether great or small, of whatever geometrical shape. Mr. Moore made a wooden copy of the stone which he gave the writer, telling him of the measures. But really the statement did not affect him, even to making a trial for the truth of the claim, merely because the fact was so extremely unlikely that it was without consideration rejected. It was not until some two or three years afterward, viz: in the fall of this year, 1882, that the writer's attention was again turned to this matter, from reading in Mr. Wilson's work, a description of the measures of the Gest Tablet, viz: length 5 inches, greatest width 3 inches, least width 2.6 inches. The fact that both were found in the same mound, and also the fact that Mr. Moore had told the writer that the elliptical stone measured "precisely 9 and 12 inches," coupled with this statement as to the Gest Tablet, determined him to make the measures of both. He spent the longer part of one afternoon, repeating the trial tests over and over again. A standard measure being used for reference, it was found that Mr. Moore had not exaggerated, but had stated a plain fair fact. The elliptical stone, on its straight edge did measure precisely 9 inches, and around its curved edge precisely 12 inches. The writer requested Mr. Joseph James to make the test also, who took the measures with the like showing. Since then it has been measured by various parties with the same results. Moreover, it was proved that the stone was approximately the symmetrical half

of an ellipse, because, by mapping it on paper, and then reversing it on its straight edge, the whole ellipse became produced. As to the "Gest Tablet," see Appendix C.

Even if the contriver of this stone had no idea of the particular unit of measure by which it would as to its straight edge measure 9 (nine) of these particular units, viz: British inches, and its circumference 12 (twelve) thereof, especially when the power and convenience of these numbers for particular architectural purposes is considered, it would seem impossible that he could have chanced on it. The fact that this unit of measure so fits in this exceedingly curious mode of making, showing and preserving a standard of measure, is proof of the general intention of the contriver. Couple this fact with another, viz: that the mound in which it was found was an elliptical one, "about 440 feet in circumference," a peculiar division of 5280 feet, (for  $5\frac{2}{1}\frac{8}{2}^0=440$ ), used much in Mound structure. Still further, connect with these the further facts which we will show, viz: that the use of this measure in the structure of the Mound Builder works, is confirmed in a great number of instances, nay universally; and that too, by an interchangeable play upon the numbers of the measures, as 12 and 21, 24 and 42, etc. Such being the condition of facts, and such is the condition of facts, one must seemingly come to the conclusion that the British inch and foot were used then just as one would have to now to recognize the measures and scale adopted in the construction of a multitude of rooms, passages, openings, etc., in any large and carefully constructed building of to-day.

This stone was found and placed in the museum before many of the surveys of Squier and Davis were made, and before any of them were given to the public. They probably never heard of, certainly they have never mentioned the stone. Its appearance is not calculated to draw attention, and so far as we can discover has never been commented on by any one save Mr. Moore. Beyond the facts, that its shape was peculiar, that it was worked, and that it was found in the mound, there was nothing about it to attract more than a passing glance. It was deposited by Mr. Gridley in the museum at the request of Mr. Carley, with some fragments of other pieces of stone found by Mr. Gridley, at the same time and place, and these are now in the collection of the Natural History Society, bearing the original labels.

To enforce what has been said as to the reliability of the reported

measures of Messrs. Squier and Davis, a number of statements made by them in their work, and bearing upon the matter, are quoted in Appendix B. They are of importance as a part of this paper, but are separated from the text that the actual measures of the works may stand out in clear relief. Premising that this inquiry is confined to what are denominated "The Sacred Enclosures," occupying the levels of the terraces as contra-distinguished from the "Fortifications," or military works, we will now proceed to the classification of the works, agreeably to certain prominent types of measures used. It will be seen that all the various types of measure are inter-related, the one with the other. While this is of the gist of this paper, it will also serve as a remarkable support to the accuracy and faithfulness of the measures reported.

#### GROUP I.

This group comprises the use of two circles, a greater and a lesser, in combination with an especial square. The square is identically the same in quite a number of instances, the identity being originally and first discovered, as asserted by Messrs. Squier and Davis, upon the compilation of work from the "Field Notes." The measure of the side of this typical square is 1080 feet. As an illustration, the plan of the works in Plate 20, page 56 of Squier and Davis surveys is given (Figure 2). This work is situated in Ross County, Ohio, eight miles south-east of Chillicothe.

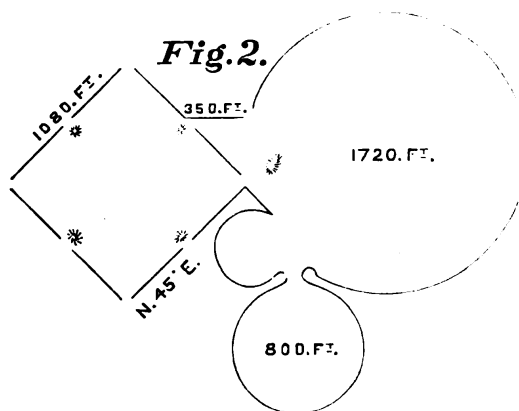

No. 1. The work just mentioned. As seen, the side of the square is 1080 feet. One circle has a diameter of 1720 feet, and the other of 800 feet. An embankment connecting between the square and the circle will be noticed, 350 feet long. 350 feet is 4200 inches, and one-fourth of this is 1050 inches. This relation

is significant, because the measure of 1050 feet is the second most conspicuous one in the mound works. So also, 350 is the reverse of 530, and 530 feet, as will be seen, is part of the side of a square forming the chord of a great circle, in the Hopeton works.

No. 2. Plate 21, page 57, (we quote from Squier and Davis work,) gives *four* works similar to No. 1, the square in each being 1080 feet to the side.

(a) A work on Paint Creek, a tributary to the Scioto River, 14 miles from Chillicothe.

(b) A work on "The Crossings of Paint Creek." The great circle is *about* 1687 feet in diameter, and contains an elliptical mound 140 feet long by 160 feet broad, and 30 feet high; also a small circle 250 feet in diameter. The length of the mound is to be noticed, for it is 1680 inches, a multiple of 42, which number, divided by 4, is 105.

(c) A work on the Scioto River, 1 mile south of Chillicothe. The great circle of this work has a diameter of about 1625 feet.

(d) A work at Frankfort, or Old Chillicothe, on the left bank of the North Fork of Paint Creek. The great circle of this work is about 1625 feet in diameter.

In addition to the works mentioned, we have as especially setting forth the measure of 1080 feet:—

(1) The great square connected with the cone and ellipse, at Marietta, on the Muskingum River. This square measures 1080 feet to the side. Plate 26, page 73.

(2) The great rectangle at Winchester, Indiana. This rectangle measures upon one side 1080 feet, upon the other 1320 feet, or just one-fourth of a mile. If we add the length of these sides, we have 2400. The number 24 is constantly being used in the works in connection or contrast with 42 its inverse.  $4\frac{1}{2}$  times 24 are 108, and 42 divided by 4 is 105. If we subtract 1080 from 1320 we have 240. Plate 33, page 93.

(3) The great rectangle at Hopeton, on the Scioto River, 4 miles above Chillicothe, connected with a great circle. One side of this rectangle is 10800 inches in length. The great circle is in diameter 1050 feet. Here the numbers 1050 and 1080 are brought immediately together.

(4) Two great rectangular enclosed parallels, each 750 feet long by 60 feet wide, or 9000 inches long, by 720 inches wide. The area of each is 45000 square feet, or together 90000 square feet. This is 10000 times 1296 square inches.



It is noteworthy that the play of the numbers used about these works is the same that is so familiar with us in our measures of space and time. 1296 square inches is one of our square yards, 4 of which, or 5184, multiplied by 1000 is the number of *thirds* in one solar day of 24 hours, measured on the circle of 360 degrees, as 15 degrees to the hour. That is, a circle of 360 degrees forming 24 hours, reduced to *minutes* and *seconds* and *thirds* gives 5184000''' as parts. It is the measure of time on such a circle that causes the transfer of the measure of right-lined shapes onto circular ones, by a fittingly chosen set of numbers, and the numbers 6, 12 and 36, have always, and with all nations, been used as the numbers for measures in common, for the two kinds of shapes, viz: rectangles and circles.  $360 \times 24$  is 8640. The half of 864 is 432, and the play upon this number is common among the nations, as 324, 243, etc. 324 is  $36 \times 9$ , as also  $108 \times 3$ , while 1080 divided by 3 is 360. The illustration on Plate 24, page 66, given hereafter, gives this as an area, viz: 90 feet by 360 feet, or 32400, with 240 by 360 which gives 86400. The use is singularly that of the very ancient Babylonians.

## GROUP II. A.

This group is characterized by a great circle, whose diameter is 1050 feet. The circle is connected with a rectangle. The illustra-

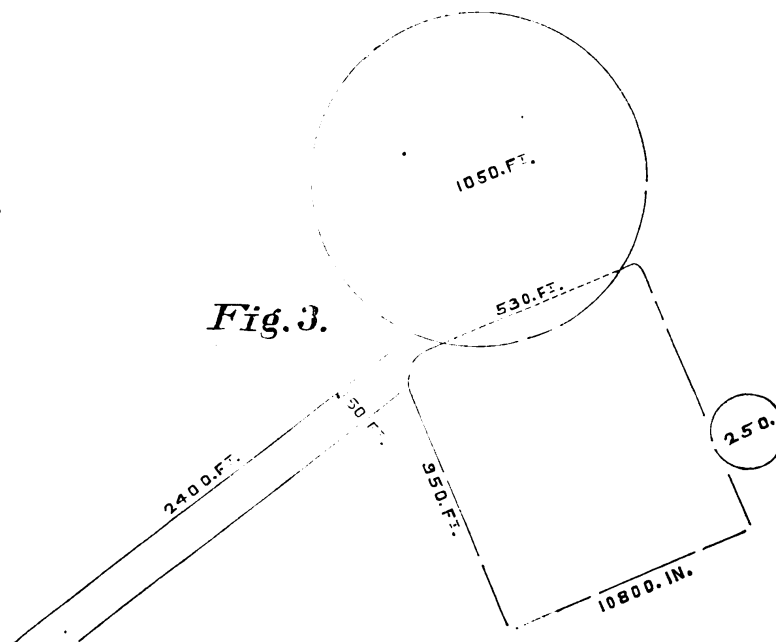

tion is the plan of the Hopeton works, Ross County, Ohio, situated on the east bank of the Scioto River, four miles above Chillicothe. Plate 17, page 51, of Squier and Davis.

No. 1. The Hopeton works. The great circle is 1050 feet in diameter. One side of the rectangle is 900 feet in length, or 10800 inches. The combination with Group I is at once manifest. The side of the rectangle makes a chord of the circle 530 feet long. 900 less 530 feet is 370 feet. Five times 370 is 1850 feet, and 1850 less 900 feet, one side of the rectangle gives 950 feet, the other side of the same.

No. 2. The High Bank works, on the Scioto River, five miles below Chillicothe, Plate 16, p. 50. Diameter of the great circle 1050 feet. This is connected with a great octagon 950 feet in diameter on a measured section.

No. 3. The Seal Township works, near the Scioto River, in Pike County, Ohio, Plate 24, p. 66. Diameter of the great circle 1050 feet. The great circle is connected by parallels 475 feet long by 100 feet wide, to a square of 800 feet to the side. As to the parallel: 475 feet is 5700 inches, and 100 feet is 1200 inches. The area is 10000 times 684 inches. 684 is but a play upon 648. Reduced one-half, 684 becomes 342, which number as said is remarkable in its various uses, as 243, 324, 432, and so on. They are all multiples of 6, as  $72 \times 6 = 432$ .  $54 \times 6 = 324$ .  $40.5 \times 6 = 243$ , and  $57 \times 6 = 342$ .

#### GROUP II. B.

Related in measure, this same number 1050 is found in the following works:

No. 1. The Cedar Bank works, Ross County, Ohio, near the Scioto River, five miles above Chillicothe, Plate 18, p. 52. They consist of a great rectangle, two and opposite sides of which measure, each, 1050 feet. The remaining sides measure 1400 feet each. At the centers of the sides of 1050 feet are entrances 60 feet wide. In the rectangle is a truncated rectangular pyramid, 250 feet long, by 150 feet broad, and 4 feet high, with graded ways leading on to it, 30 feet broad. Near the rectangle is an enclosed rectangular parallel, 870 by 70 feet. Near by is a group consisting of a square of 120 feet to the side, 9 feet high, and a circle 250 feet in diameter, having an entrance 30 feet in width. 250 feet less 30 is 220 feet, the characteristic measure of Group III.

1050 feet is 12,600 inches, the half of which is 6300. The number 63 feet is found on "*The Bird*" in the Newark Mounds and elsewhere. The third of 63 is 21, the inverse of 12, and  $21 \times 5 = 105$ , while  $12 \times 9 = 108$ .

No. 2. The Junction Group, Ross County, Ohio, on Paint Creek, two miles south-west of Chillicothe; Plate 22, page 61. This group, in the connection, is exceedingly noteworthy, as it shows a play upon the numbers 210 and 120, the sources respectively of 1050 and 1080. It consists chiefly of two circles which touch upon the opposite sides of a regular square, contained in a larger square, whose sides are much rounded, almost circular.— One circle is 120 feet in diameter, the regular square is 120 feet to the side, surrounded by a bank whose shape partakes of the nature of a square and a circle. The circle upon the opposite side is 210 feet in diameter, or  $105 \times 2$  feet; hence, the unit of measure is 105 feet. Near this last is another circle 210 feet in diameter. Off to one side, at some distance, is a regular square of 160 feet to the side, in a very symmetrical figure, 240 feet across, with sides much rounded, and which partakes of the shape of the circle and the square.

No. 3. The remarkable "Graded Way," near Piketon, Pike County, Ohio; Plate 31, p. 88. The measures of the "way," combine, in a special manner, those of Groups I and II. One section of this "way" is 1080 feet long. From this proceeds an embankment 1500 feet long, at the end of which a bank runs off at a slight angle, a length of 420 feet. In the side of the long line, and at right-angles to it a bank projects 212 feet, then an elbow runs parallel with the main line 420 feet, and from the extremity of this last, diverging from it at a slight angle, a bank runs in towards the main line a distance of 240 feet. Here is unmistakable evidence of the purposed combination of the characteristic measures, 1050 and 1080 feet, of Groups I and II. 24 feet is  $6 \times 4$ , while 42 feet is  $6 \times 7$ . The fourth part of 4200 is 1050, while  $180 \times 6 = 1080$  feet. So, also,  $212 \times 2.5 = 530$ , the chord of the circle in the Hopeton works, where 1080 is directly connected with 1050.

No. 4. The Portsmouth works in Kentucky, opposite to the old mouth of the Scioto River; Plate 28, p. 78. This work consists of two ways, or parallels, each 2100 by 210 feet, converging from opposite directions on a square of 800 feet to the side. The

unit of measure is evidently 105 feet; or 21 as the inverse of 12. So 105 feet is 1260 inches, and the number 126 is quite a famous one among the ancients, especially in Hebrew Cabbalah.

The fact is, these relations of measures so pervade the entire aggregate of the surveys in the work of Squier and Davis that it would be tiresome, and really unnecessary, to repeat almost all their labors simply to force attention by mere accumulation.

#### GROUP III.

This group is characterized by the use of the number 110, in combination with 1080 of Group I.

The number 110 is derived from the number 5280, which, *in feet*, is one mile in our measure. The divisions of this number give the controlling measures of this group. The number 24 and its inverse 42, gives rise to the numbers as measures, controlling the construction of the works in Groups I and II; and 5280 divided by 24 is 220, and the half of this is 110, which, with its multiples, make the prominent measures in this group.

The illustration, "Figure 4," is the rectangular ancient work near Winchester, Randolph County, Indiana; Plate 33, p. 93.

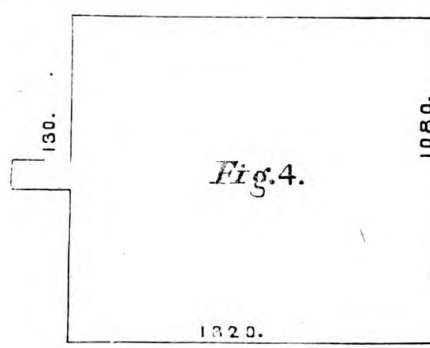

No. 1. This rectangle at Winchester. It is 1320 feet in length, on one side, by 1080 feet upon the other. 1320 feet is one fourth of one mile. 1080 feet as a measure, characterizes the works in Group I.  $1320 + 1080 = 2400$  feet. In the Newark elliptical work, the number 2400 feet is divided into 1250 and 1150 feet, to make the conjugate diameters. 1320 less 1080 shows the lack to make an exact square. The difference is 240 feet. 1320 is 12 times 110.

No. 2. Rectangle shown in Plate 32, p. 91. It is 220 feet long, by 120 broad.  $220 \times 120 = 26400$ , or  $13200 \times 2$ .

No. 3. Rectangle shown in Plate 29, p. 82. It is 550 feet long, by 630 feet broad. 550 is 10 times 5280 divided by 96. The difference between 630 and 550 is 80 feet, or 960 inches, in the digits of which number we have the divisor of 5280 to give the number 550.

No. 4. Plate 28, p. 78. The work is an oval 110 feet long, by 60 broad (the plans say 70, letter press 60). On the same plate is shown a mound 110 feet in diameter at its base.

No. 5. Plate 23, p. 63. This is a group of 7 circles. Three have a diameter, each, of 130 feet, one of 200 feet, one of 210 feet, and two of 110 feet, each.

No. 6. Plate 36, p. 98. The work is called in the text "The Greek Cross," and is given "Figure 5," because of a remarkable

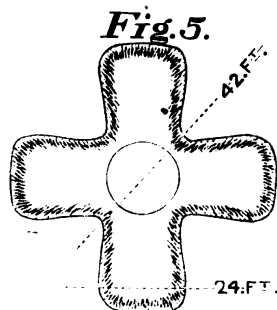

combination of the numbers 42, 24 and 12, and because the foregoing will almost justify the statement that a connection is intended to be shown with the number 1320 feet. The length of the Cross is 90 feet, or 1080 inches. The width of the end of the arm is 24 feet, while the diagonal of the body is 42 feet, one-fourth of which is 10 5 feet. The circle in the center is 10 feet, or 120 inches in diameter. But what is peculiar in this connection is, that if 42 be taken as the diameter of a circle, then the addition of less than  $\frac{8}{1000}$  of a foot, will give a circumference of 132 feet for the circle, which is the tenth part of a quarter of a mile. Of course, speculation is not allowable in a research of this kind, which is simply to tabulate measures given; yet, from the lesson of these three groups of measures, it becomes easy to imagine that this number 42, was intended to suggest connected relations of the three groups in one figure. This work is 3 feet, or 36 inches high.

With very few exceptions these three groups of measures are involved, in some way, in all the surveyed works of the ancient "Sacred Enclosures," given by Messrs. Squier and Davis. The

groupings themselves, show, by the extraordinary variety, yet perfect dependence, or rather inter-relation, the one upon or with the other, that the surveys *were actual*, and the measures correct as reported. The impression produced by the investigation of the reported measures of these works, is almost irresistible that they are constructions of to-day, made by use of our standard measures, in the familiar denominations thereof. So strong is this impression that unless fortified against proof to the contrary, it would appear that no reasonable man can believe the exact measures were correctly reported by Col. Charles Whittlesey, and by Messrs. Squier and Davis, and this even in the face of the high standing of these gentlemen, and their reiterated averments that their measures were carefully and minutely taken "with compass, line and rule," and were reliable.

I have tried, as far as possible, to make their own assertion as to their measures good, by intrinsic evidence, and judge that this has been done; for certainly no one could suspect them of purposely making so elaborate and coherent a system of inter-related measures, either when taking the surveys, or, as an after-thought, when the "field notes" were brought together. It would have been preposterous for them to have attempted such a thing, nor had they tried, could they, unless by notable perversions, and with very great labor and ingenuity, have fabricated with a different set of measures than used by the Builders, a fraud which would have borne the test of such an analysis as the above.

The discovery of a unit of measure, which exactly fits to the construction of all these works, showing so perfect a system, *as reported*, was the one thing wanting to justify the measures themselves as being rightly taken, and to perfectly satisfy the most skeptical. This discovery was made, as already stated, by Mr. R. B. Moore, in the elliptical stone in the treasures of the Natural History Society. It is simply our "*two foot*" rule over again, but connected with another unit of measure, which we do not possess, viz: that of 9 inches.  $9 \times 12 \text{ inches} = 108 \text{ inches}$ ,  $12 \times \frac{7}{8} = 10.5$ , or  $9 \div 12$  divided by 2 equals 10.5 inches, while  $12 \times 44 = 528 \text{ inches}$ . The application of these very simple grades of measure explains the base of the construction of all the ancient "Sacred Enclosures" of the Ohio Valley. Dr. Drake reported the measure of the elliptical mound in which the measuring stone was found, as about 440 feet in circumference.

(To be continued.)









[From THE MASONIC REVIEW for November, 1886.]

[From the Journal of The Cincinnati Society of Natural History, October, 1886.]

## The Identification of the British Inch as the Unit of Measure of the Mound Builders of the Ohio Valley.

Paper Contributed by J. RALSTON SKINNER, Dec. 1, 1885, to The Cincinnati Society of Natural History.

### GROUP IV.

Can we not admit, then, as established, that the Mound Builders possessed a standard unit of measure, which is to day known and used as our British inch? If so, they possessed a standard of 12 of these inches, combined on the same tablet with one of 9 inches, the tablet being of such a form that the 12 implied the use of 24 inches. This arises from the natural suggestion of completing the ellipse by doubling the curvature of the elliptical measuring stone or tablet. In making use of their tablet we find that they applied the same numbers interchangeably as designative of sides of squares, of rectangles, of lengths of long parallel ways, and as connected with circles (and ellipses), both to measure diameter and circumference lines. Indeed, the relation of square to circle, in terms, for measure of the general constructive numbers, or simpler, in terms of the number 6 and its multiples, is everywhere beyond contradiction manifest.

From this it becomes safe to say that this mode of construction rested upon a knowledge of the relation of a right line to the curved one of the circle, or of diameter to circumference of the circle; and consequently of the relations of circular and rectangular areas. The Mound Builders knew of the geometrical relations of these shapes, of their numerical ratios, and had the peculiar standard of measure mentioned to exhibit the numerical relations by application to the shapes themselves. We will try and show this from the works.

The exception is so rare to the use of the multiple of 6 feet, or to the numbers 210, 120, 420, 240, 1,080, 1,050, and the divisions of 5,280, that when found it is worthy of especial attention. Such an exception does take place as to the measures of one great and distinctive work, and one of the groups of works of the Scioto Valley, near Chillicothe. But while it is such an exception, nevertheless we do find its remarkable measures connected with *the combination* of the most prominent measures of the groups, viz., 1,080

and 1,050, so as to show the numerical relation of diameter to circumference of a circle. We will show this, but will first set forth one work, which directly and significantly shows the knowledge of the circle of 360, connected with the measure of 240 and 90 feet, or 1,080 inches. This work is part of the Seal Township Group, in Pike County, Ohio, near the Scioto River, Plate 24, p. 66. In this group are some of the most perfect figures of the circle inclosing a square, the diameter of the circle being 300 feet, and the side of the interior square 125 feet, and of the ellipse. As to the circle and square the authors say: "Nothing can surpass its symmetry," and further: "It will be remarked that we have here the square, the circle and the ellipse, separate and in combination—all of them constructed with geometric accuracy." As to the work to be shown, "Figure VI.," they say: "Its outlines beautifully distinct;" and they conclude: "It is impossible to resist the conviction that some significance attaches to these singular forms"

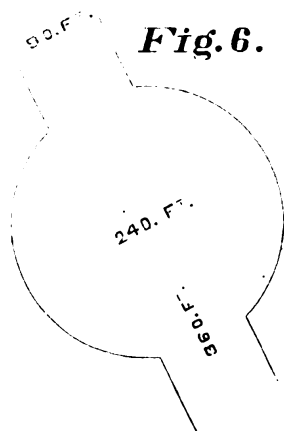

Here, in Figure VI., we have the circle of 240 feet in diameter  $240 \times 8\frac{1}{2} = 1050$ . The width of the passage way through the circle is 90 feet, or 1080 inches, 1080 divided by 3 is 360, and the length of the passage way is 360 feet. This is 4320 inches. The length of each arm of the passage way is 60 feet, or 360 inches multiplied by 2, 360 less 120 is 240 feet, the diameter of the circle, or 2880 inches, the circumference, in feet, of the famous Newark circle, which will be given in its place. 4320 less 2880 is 1440, 144 being the square of 12.  $432 \times .75 = 324$ , twice which is 648. These two numbers, viz.: 432 and 324, were especially used with

the Chaldeans and ancient Babylonians, or pre-Semites. With the Chaldeans, from the beginning to the deluge was 120 *sari* of 360 years each, or 43,200 years. In the very most ancient Babylonian account of the flood, taken by George Smith, from the cuneiform tablets of Nineveh, the use of this number with 1080 and 360 is made so as to bring out a play upon these numbers, 432 and 324. Khasisatra is relating to Ishdâbar (Semitic compound word, meaning “*Man-Word*”) the events of the deluge. He says, in regard to constructing the Ark, and furnishing it: “I poured on to the exterior 3 times 3600 (10800) measures of asphalt, and 3 times 3600 (10800) measures of asphalt within. 3 times 3600 (10800) men, porters, brought on their heads the chests of provision. I kept 3600 chests for the nourishment of my family, and the mariners divided among themselves 2 times 3600 (7200) chests,” that is, each porter had 2 chests. Here 10800 is used 3 times, making 32400, or our number 324. Add 3600 mentioned once and we have 36000, to which, if we add the remaining 7200, we have 43200, wherein, by the combination, we obtain the other of our numbers, 432. The intention to show the relation is obvious. These are the familiar numbers, with a like play upon them, in the Mound Builder works, but with the relation established as an interchangeable play upon geometric shapes and linear measures. The Chaldean account uses the numbers with relation to time and capacity measures, and men. The probably most important use of this number 432 with 234, was astronomical. Together, 432 and 234, make 666. We see that  $10800 \times 3 = 32400$  is a manifest play upon the number 432, and 32400 is the half of 64800. Let 64800 feet be the circumference of a circle, that is practically the circumference of the great Newark circle,  $2880 \times 22.5$ . The diameter of this circle will be 20626.4700+feet. But as *seconds* in *time* measure 20626.4700 *seconds* is the *radius* seconds of a circle whose circumference is 360 degrees, and this particular radius is made use of in the common astronomical formula of today for finding the sun’s distance. So, also, the ancient Egyptian cubit, “Nilometer,” has been measured as 20.625 British *inches* (Wilkinson). Use it as 20.62647 B. inches, a difference of .00147 of an inch in 20+inches, and the details of construction of the Great Egyptian Pyramid can be recovered, in the *actual measures* (British) made of those details by the most careful experts. Now,

20625 is, of itself, a most important number, and shows itself in the constructive frame-work of the *denominations* of the British measures which were used by the Mound Builders, as we see, and by the ancient Egyptians. So, that in these mound constructions, we not only have the peculiar play of numbers common to the old Chaldeans and Egyptians, but also the same numbers applicable with the same identical unit of measure, viz.: the British inch. Let us explain this. It is objected to the British measures that they are imperfect, because, in the make up of the *rod*, a fractional number of *yards* and *feet* is made use of. The objection is a very short-sighted one. 16.5 feet, or 5.5 yards make one *rod*. The *acre* is made by a rectangle 5280 feet, or one mile in length, by the half of one rod, or 8.25 feet, in width, and 640 of these rectangles make one square mile. It will be observed that the length of one mile is 528 feet multiplied by 10; also, that the half of one rod is 8.25 feet, which, as a *number* reads as the *reverse* or inverse of 528, indicating in feet the 10th of one mile. Is this peculiarity of inverse arrangement chance, or purposed? The latter, for they are changes derived from a common source, which, numerically, connects itself with the proportional elements of the circle, and those of the especial circle of 360 degrees alluded to. Divide 5280 by 256 and the quotient will be 20625, and divide 825 by 4 and the quotient will be 20625, the very number of the reported measure of the Nilometer Cubit. Thus, the number 20.625 in relation to our British mile is an essential part thereof as a common factor in the make up of its denominations of measure, while 20.625 B. inches is, as seen, measured as the recovery of the ancient Egyptian Nilometer Cubit. But the relation extends further. The late John A. Parker discovered the integral proportional relation, numerically, of circumference to a diameter of a circle to be 20612 to 6561, the latter being the square of 81, which is the square of 9, which is the square of 3. This 20612, as 20.612 B. inches, has been shown to be the recovery of another ancient Egyptian cubit, called the Turin cubit,\* out of which springs the other or Nilometer cubit, thus:— 20.612 B. inches : 6.561 : : 64 8 : 20 6264700 inches or the Nilometer cubit, in the last two terms of which proportion we recognize the numbers mentioned above.

\*This Egyptian cubit measure in the Turin Museum was measured with microscopic accuracy, by Bidone and Piana, and found to be .523524 of the French *me er*, or 20.61172 + British inches; evidently from a great number of tests and for convincing reasons, one of the two royal cubits, viz.: 20.612 inches, the other, as shown below, being 20.62647 inches.

Now, therefore, at the very center of a system of every variety and diversity of measures, we have *three* numbers *almost identical*, and each one a key to a variety or family of the system, viz : 20612, 20626.470017 and 20625. It was a part of ancient usage to obtain from simple numbers, easily carried in the memory, the use of fundamental ones. The number 20625 is easily had and easily discovered, and in our mound measures we have a key, viz. : 12 and 21 feet. 7 times 21 feet is 147 feet, and  $20625 + .0000147$  is 20626.4700, or one of the other numbers ; while 20625 less 13 (and in the mounds we have a number of instances of the use of 13, in one special instance, connected markedly with the numbers 110 and 210, pointing directly to this very use) is 20612, the third of the famous trio. Now, all these shapes, measures and numbers, are presented in the Mound Builders' constructions, and doubtless these very readings, were we sufficiently familiar with the use and relations of numbers, because the uses spring so easily and naturally from the abundance of measures afforded, as the same measures are related to each other in construction. Everything points to the fact that the Mound Builders not only knew the  $\pi$  relation, but also by use of the very numbers specified by their uses in measures.

But, moreover, and what is a most singular fact, they did set it forth quite distinctly in a secondary and derivative form, and one which the writer has found to be used in the self-same secondary way among the Asiatic ancients, which form is numerically, diameter 113, circumference 355.

This form is very ancient\* and yet very modern. It is to be found in our elementary works. The established  $\pi$  is 3.1415926, while this is 3.1415927

Such is what the writer judges to be justifiable comment upon Groups I and II and III, together with this remarkable work of Seal Township, Pike County, Ohio. And now to resume the direct line of investigation thus interrupted.

---

\*It is found used in the books of Moses as a modified form of the  $\pi$  ratio 6561 to 20612, and while the last is the base of a cubit measure, this one of 113 to 355, is used chiefly in matters of measures of time, especially in the symbolism of the scenes of Mt. Sinai. The multiple of this last ratio by 6 is 678 to 2130, which numbers are found in the Hebrew Bible as measures, (1) in the symbol of the circle of a "head" or the word RASH, whose numbers are 213—(2) in the hieroglyphic use of the "Dove" and "Raven," whose numbers as 135 are  $7 \times 5 = 355$ , and the word "and the raven," the sum of whose numbers is 678, and (3) in the Zodiacal sign of the "Two Fishes," the word "Fish" or *NUN* carrying the numbers 565, which multiplied by two equals 1130, and so on : which 2130 is the sum of 1080 and 1050, the measures found so typical and prominent in mound construction, in grouping different works, as seen.

As stated, the exceptions throughout the various works to the use of the typical numbers of measures is exceedingly rare ; and certainly one of the most noteworthy is to be found on Plate 23, p. 63. This exception embraces "The Dunlap Works, Ross County, Ohio." They lie within one mile of the Cedar Bank Works, and within two miles of the Hopeton Works, already cited, consequently they can be taken as partaking of the nature of, and as a connected branch of development of the works of the Scioto Valley, the Newark Works, the Marietta Works, and so on. They are situated on the right bank of the Scioto River, six miles above Chillicothe. The copy of the survey is given as Figure VII.

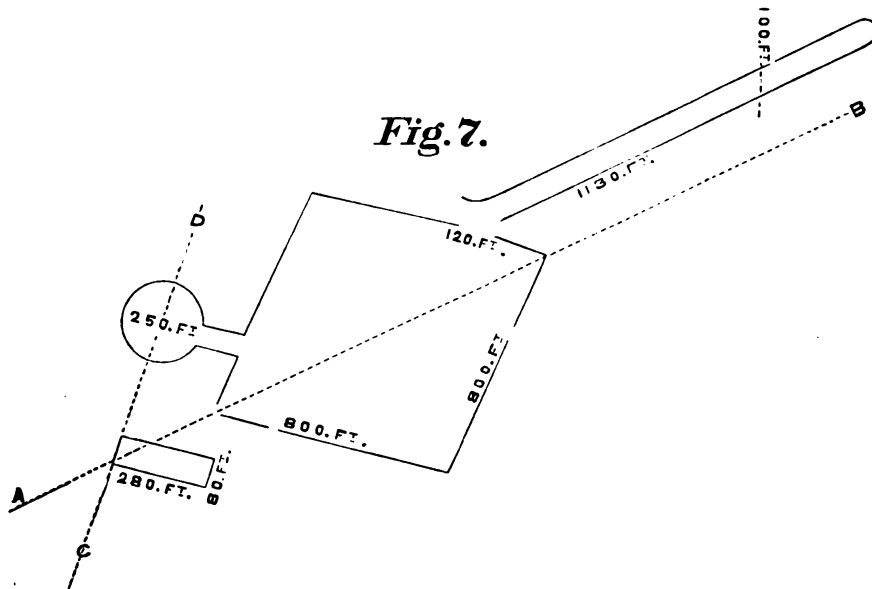

Upon examination of the original plan the construction is singular, though not noticed by the surveyors. A trial test line, *a b*, parallel to the long way, is the diagonal of the irregular square, and extended locates the corner of the rectangular out-work, whose long side is parallel to one side of the square. Constructing the rectangular out-work, the extension *c d* of its short side passes through the center point of, and as to a part, becomes the diameter line of the circle attached to the square. Thus the measuring numbers of these various parts become related to each other by geometrical construction.

On the long way of 1130 feet it will be observed the surveyors have shown a line 100 feet long, as its height (of breadth) vertical to the horizon. The rectangular out-work is 280 feet long by 80 feet broad, and its area is 22400 feet, the half of which is 11200 feet, to which, if 100 be added, the sum is 11300 feet, or 10 times the length of the long way. The same may be shown in this way: The height of 100 feet taken from 10 times the length of the long way, or 11300 feet, is 11200 feet, twice which, or 22400 feet, equals the area of the rectangular out-work. By this we are led to look to the divisions of the figures, or component parts thereof, by 2, and the use of such parts by means of additions and subtractions to show intended interrelations. So, also, we are taught by all the measures of the groups: (1) that the reverse or inverse reading of key numbers is used to produce as keys, other and controlling and correlating relations, such as, 24 may be used as 42, 528 as 825, 21 as 12; (2) that key numbers are divided into other parts to apply to differing geometrical shapes, as for instance, 2400 feet, the length of a long way, is divided into 1250 and 1150 feet, to show the conjugate diameters of an ellipse, and so on.

To show the application: Part of  $cd$  forms for, such purpose, the diameter line of the circle, which, is 250 feet long, and this naturally divides into halves of 125 feet each, to form the radii of the circle. By sympathy 280 feet the length of the out work, connected, as seen, with this circle, and with the long way, may be divided into halves of 140 feet each, so that from these parts we have the numbers of 140 and 125 thus desired. We see the number 8 used about the works as the digit of 80 and 800. Divide 1130 by 8, and we have 14125, which is the sum of the two numbers, 140 and 125, used as  $140 + 00125 = 14125$ . Such relations show a purpose of checking, using and emphasizing the measures and parts of measures of the various parts, by means of geometrical construction; but in this case all serve to concentrate upon and point to the number 1130.

But again take the measures and parts of measures of the out-work, located as a connecting constructive link between the 1130, and the 250 and 125 of the circle. 140 feet is 1680 inches, the eighth part of which is 210 inches, while 80 feet is 960 inches, the eighth part of which is 120 inches. Here we get the 21 and 12, which from the standard of 12 and 9 inches on the elliptical stone



produce 1050 and 1080, the key numbers of the work in general; for  $21 \times 5 = 105$ , and  $12 \times 9 = 108$ .

What can there be of significance about the combined use of these two numbers, 1050 and 1080, fitting them to the scheme of common measure, adapted interchangeably to differing geometrical shapes, as, for instance, squares and circles?

Add together 1050 and 1080, and we have 2130. Divide this number by 6 and we have 355. We all know that 355 is the peculiar number, which, related to 113, gives in integrals the closest approximate numerical relation of diameter to circumference of a circle ever discovered in modern times, until John A. Parker found that  $6561 : 20612$ . And this seems to be the intended teaching of this group of the Mound Works.\* It affords the numbers by which the geometrical relations of squares and circles can be interchangeably related or compared; while the other groups make such relations and comparisons, by the units of the standard practically adopted for actual measure. Which unit refers to a basis of numbers by which measures of space and time may be correlated on squares and circles. The whole scheme, so far as geometry and numbers are concerned, is one which would naturally develop with all or any parts of the human race, independently of location, climate or family. That which could not be so developed would be the same *practical unit of measure* adopted by which all relations might be shown in constructed works. We may adopt it as a truism that all people making use of this practical unit of measure must have derived it from a common source. The Mound Builders possessed it, so did the Old Egyptians, Hebrews, Romans, and, in modern times, the British people.

#### GROUP V.

This somewhat long and analytical investigation can now be appropriately closed with a description of the famous Newark Works, Licking County, Ohio, Plate 25, p. 67; upon the detailed measures of which the greatest pains were bestowed by Mr. Charles Whittlesey, Mr. E. G. Squier and Dr. E. H. Davis. As to the plate, it is

---

\*While 1130 denotes a diameter to a circumference of  $355 \times 10$ , if 1130 be taken as a circumference value, it will in whole numbers indicate (with a decimal expression) a diameter of 360. With the Egyptians the Hebrew term Pharaoh was the number 355, the lunar year; which year was with the Hebrews the word *Shemah*, which carried this numerical value in the value of the word, while with both Egyptians and Hebrews they had the year of 360 days. The smaller lunar year of 354 days was "Pharaoh's daughter."

said by the authors: "The map here given is from an original and very careful and minute survey made in 1836, by Charles Whittlesey, Esq., Topographical Engineer of the State of Ohio, corrected and verified by careful re-surveys and admeasurements by the authors. It may be relied upon as strictly correct." The chief object of giving this work is to show that the numbers of measures, viz., 24 feet, heretofore used on right lines, are transferred to designate the circumference of a circle. In the Hope-ton Works we have a parallel way 2400 feet in length, connected with the great circle whose diameter is 1050 feet, and with the great rectangle whose side is 1080×10 inches. The especial feature of the Newark Works is the great circle of  $24 \times 120 = 2880$

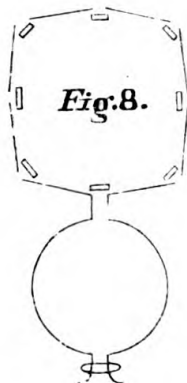
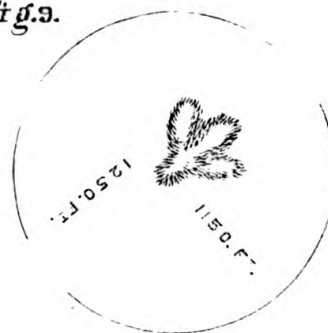

Fig. 9.



feet in circumference, and the great ellipse whose conjugate diameters are, respectively, 1250 and 1150 feet in length. It will be seen that the sum of these diameters is 2400 feet, 12 times which is 10 times 2880, the circumference of the great circle, while their difference is 100 feet, or 1200 inches; so that the ellipse is made to be related to the circle by the length of the sum of its conjugate diameters. The circle, as is seen, Figure VIII., has a circumference of 2880 feet. Of it the authors say: "Unlike the other circular work, *this is a true circle*, two thousand eight hundred and eighty feet, or upwards of half a mile in circumference." It is connected with the octagon by a passage way 300 feet long by 60 feet wide. Recess to "Crown Works" 100 feet, about. Length of mound across crown work 170 feet. Within the octagon there are 8 mounds, rectangular, truncated pyramids, each 100 feet long by 80 feet wide at base, and 5 feet high. Here, at once, the relation of these works within the octagon to the circumference

of the circle becomes manifest. 100 feet is 1200 inches, 80 feet is 960 inches, and 5 feet is 60 inches,  $960 \times 120 = 115200$ , the  $\frac{1}{40}$  of which is 2880 inches, the number, in feet, of the circumference of this circle. So, also, the octagon is a shape of 8 sides, and  $2880 \times 8 = 23040$  which is 11520, or the area of the base of one of the mounds in the octagon, multiplied by 2. Moreover, this relation is also extended to the conjugate diameters of the ellipse. The sum and difference of 1250 and 1150 are, respectively, 2400 and 100 feet, or 28800 and 1200 inches, and the sum of the sum and difference of these is 57600, two-tenths of which is 11520, and the  $\frac{1}{20}$  of which is 2880.

The ellipse is especially remarkable for the so-called "bird structure" which it contains, and its measures. As the circle is connected with an octagon, so the ellipse is connected with a square. The "bird mound," in the centre of the ellipse, affords, by reason of the measures of its various parts, a table of selected measures, the most of which are of familiar use throughout the groups in the valleys. It affords a table of typical measures. The description is as follows: "It can hardly be called a mound, but is rather a group of four, so arranged and connected as to constitute an unbroken outline. Denominating the figure, for the sake of distinction, a bird, the dimensions are as follows: Length of body 155 feet; of each wing 110 feet; (difference 45 feet); between the tips of the wings,\* measuring in a right line, 200 feet; width of body 63 feet; of wings in center, 45 feet; of the same next the body, 40 feet; height of mounds composing the body, 7 feet; of mounds composing the wings, 5 feet. The head of the bird points directly towards the entrance of the enclosure. The bearing of the body is S.  $65^\circ$  E." Seriatim, the same measures in inches are 1860, 1320, 2400, 756, 540, 480, 84, and 60 inches. Here are the roots of our typical measures:  $6^3 = 105$  and  $63 + 45 = 108$  110 is of itself one, and  $110 \times 12 = 1320$ , which is used; and  $1320 \times 4 =$

---

\*The use of *wings* calls to mind the Hebrew "*cherub*," which, in its great variety of forms, had one common feature, viz.: these "*wings*;" and these were certainly used as types of measure. (1) in the division of the length of the Ark of the Covenant, or 2.50 cubits, into two parts, viz.: 1.25, and 1.25 cubits, which division indicated the use of the two stones which were placed therein (*abu*, 125, *abu* 125). These were to indicate, in connection with the name Jehovah and Sinai, the measures of the lunar year, for the sum of the squares of the two sides of a square, the side being 354.3670548, the exact value of that year in days will be 521125, the square root of which will be 5011506, the diagonal of the square, a proposed change on the numbers of Jehovah's name and Sinai, to monument this astronomical value, and (2) in the division of the 20 cubits of the Holy of Holies by the wings of the cherubim. In the Hebrew Bible the ratio 113 to 355 is called "*The man* (113) *even Jehovah measure*."

5280.  $105+108=213$ , and  $2\frac{1}{8}^3=355$  which, with 113, measures the elements of the circle.

And now let us notice the fact of an identity of measures, by means of numbers of measures applied to geometrical relations, of these works with those of the Great Egyptian Pyramid. We have identity of idea, identity of interrelation as geometrical shapes by common numbers, and *identity of the unit of measure* to accomplish this; a strange combination when we think that this identity applies to works on two separate continents; to one structure called the "wonder of the world," the evidence of the height of civilization, removed back in time beyond history, and to others which belonged to a race removed in time far back of the Egyptians, a race whose bones in the valleys are so "very dry," as to have turned to powder, and a race which as yet had no tool to cut stone to build into their structures as the Egyptians did.

The diameter of a circle whose circumference is 2880 feet, is 916.7320+feet, and 2880 is a multiple of 24, for  $24 \times 120 = 2880$ . We have seen how intimately the numbers 1080 and 1050 are connected with 24 and 42, and how favorite a use the reversals of numbers are, as 12, 21, 24, 42; and so we might note it of 105 as 501, and 108 as 801.

Now the base side of the Great Egyptian Pyramid is 763.943+feet, or diameter of a circle whose circumference would be 2400 feet. 763.943+feet is 9167.320+inches, which number, divided by 10, is 916.7320, or in feet the diameter of the Newark Mound circle. But we can carry the connection further. The half base side of the Great Pyramid is 381.971+feet, and  $\frac{9}{10}$ ths of this is 343.7745+feet. This is the length of the Descending Passage Way in the Pyramid. But 343.7745+is the diameter of a circle whose circumference is 1080, and 3437.745+minutes, is radius minutes of the circle whose circumference is 360 degree. All the interior construction of the pyramid is built upon the use of the length of this passage way, which is 260 Nilometer cubits. So, also, the Hebrew divisions of time, the least and greatest, in the year, were embraced by the number 1080 (Basnage).\*

One word more and we will finish. The reversed use of numbers is a favorite one with the old Hebrews in their Sacred Records.

---

\*That is, with the Hebrews, their least measure of time was the division of the hour into 1080 *chiliakim* or scruples, while the sum of the measures of the great circles of time were 355 days for the lunar year, 360 days for the calendar year, and 365 days for the solar year, together  $355+360+365=1080$  days.

Here, with the Mound Builders, the writer finds it again, and these are the only instances of his finding it, with the one solitary exception of the measures of the rectangular area to make one British acre, wherein such area is  $528 \times 10 = 5280$  feet long by 8.25 feet in width, the numerical value 528 being reversed to 825 (8.25 feet being the half of one rod).

After the close of the above, the writer visited Col. Charles Whittlesey, in Cleveland, Ohio, who personally assured him of the accuracy of the measures of the mound works referred to in the foregoing. He also stated that he himself had a manuscript lately completed, his own independent attempt at finding the standard of measure of the Mound Builders. He obtained it by finding an even factor which would apply in common, with various multiples, to some eighty measures of the mounds, selected as within his own knowledge to be relied on as accurate. This manuscript he shortly after published, and as I now recollect, found upon measuring his "*factor measure*," that it was 30 British inches. By this it will be seen that two trials for such a standard, independent of each other, result in finding exact multiples of a common unit, viz.: the *British inch*.

#### APPENDIX A.

*The History of the "Gridley Measuring Stone," or the Elliptical Stone found in the Fifth and Mound Street Mound, in the City of Cincinnati.*

In the collections of Indian relics belonging to the Cincinnati Society of Natural History, is a small one, each member of which bears the printed form of label belonging to the old society called The Western Academy of Natural Sciences, formerly existing in the same city. The members of this small collection are labeled as follows. "No. 3, Indian relics, deposited by C. P. Gridley." "No. 5, Indian antiquities, deposited by C. P. Gridley." "No. 6, Mound relics, deposited by C. P. Gridley." "No. 7, Mound relics, deposited by C. P. Gridley." "No. 12, Mound, Fifth street, deposited by C. P. Gridley." "No. 13, Mound, Fifth street, deposited by C. P. Gridley." Of these the semi-elliptical stone measure of the text, the measures of which are there given by 9 and 12 inches, is the one labeled as "No. 5." This group, or small collection, passed, with the rest of the collections belonging to The Western Academy of Natural Sciences, into the posses-

sion of The Cincinnati Society of Natural History on its organization, and has been in that possession ever since to this date, February, 1883. This collection, so labeled, consists of three fragments and two entire specimens; the two that are entire, being, first, the semi elliptical stone measure, or the "Gridley Measure," and second, a fine slate relic, of a shape lately described by Mr. Gridley.

The current tradition relative to this group has been that it consists of relics which were found in the Fifth and Mound Street Mound. Little, if any, special attention has ever been paid to these relics. They have, to appearance, nothing to attract more than a passing glance, and seem valuable only in the general sense of being veritable Indian remains pertaining to our locality. Beyond this current report no certainty attached to them until December 5, 1878. On that day Mr. C. P. Gridley called upon Dr. H. H. Hill, of Cincinnati, a member of and an officer of the Cincinnati Society of Natural History. Mr. Gridley's object was to obtain possession again of the Mound Builder relics above mentioned, which he had loaned the Western Academy of Natural Sciences, and which, as said, had passed into the possession of the Cincinnati Society of Natural History. It seems that Mr. Gridley had moved to the city of Springfield some twenty-five years previously, where he had since lived, and where he now, at this present writing resides. Mr. Gridley made a statement to Dr. Hill as follows :

" CINCINNATI, December 5, 1878.

" Mr. C. P. Gridley, of Springfield, O., this day called on me and stated that he was for many years a resident of Cincinnati, but moved to Springfield twenty-five years ago. While living here, and during the time the mound known as the Sixth and Mound Street Mound was being cut down, he frequently dug in it to see what he could find. After it was cut through, exposing the bed of ashes, charcoal, etc., (described by others) in the bottom of the mound, he dug into the bank immediately over the center of the ash bed, 3 or 4 feet above the level of the surrounding earth, and found some flint arrow and spear heads, two stone chisels, one slate ornament with a hole through it, several fragments of flat stone, which he thought had been ornaments, and one flat stone with beveled straight edge, while the other was of an ovate form, wide at one end and

running to a point at the other ; length perhaps 10 inches ; material fine grit stone— might be sand stone. ‘ At the request of Mr. S. T. Carley I deposited the above described relics in the collection of the Western Academy of Sciences, with the understanding that I could have them at any time he (I) wished to take them away.’ He now wished to do so. After explaining to him how they were turned over to the Cincinnati Society of Natural History, and the difficulty of getting the matter satisfactorily before the parties concerned in the matter, he seemed to think it rather useless to attempt to get them. This interview was very satisfactory to me, as it settled in my mind the origin of the specimens, or in other words, the fact that they were taken out of the mound known as the Cincinnati or Sixth and Mound Street Mound.

(Signed)

“ H. H. HILL.”

While this statement was (as it is) of undoubted value as regards the relics, yet the exceedingly great value of the “Gridley Measure” as a discovered unit of measure belonging to the Mound Builders and the construction of the “Mound Works” of the Ohio Valley, made the writer collect all the facts possible with regard to it, and he wrote Mr. Gridley, receiving the following replies :

“ SPRINGFIELD, Clark Co., O., Jan. 29, 1883.

“ DEAR SIR :—Yours of the 18th is received. In answer to your inquiries I would say that at the time of the removal of the mound I was residing on Longworth street, near Mound street, and often dug in it to find what I could. The relics were about 4 feet above the base of the same, and over a bed of ashes and charcoal, in which were found several skeletons partly in the ashes. I found the stone of this shape , and one with a hole in it, 2 stone chisels, and rough stone used to sharpen chisels on, and a copper ring which was on an arm bone of a skeleton. It broke in two after I found it and before I left it with the Antiquarian Society. If you will refer to Mr. Carley’s antiquarian book you can find the day and date when deposited and the several items found. I believe they were found in the spring of ’46. If you will call on the man who owns the lot he may be able to inform you of the year. As to the Gest stone, I believe it was found after mine. I think I saw it. The earth was deposited on Columbia street or Second street—the mound earth. If I could see you I could give you a description of what I found ; but did not retain. I sold to Dr.

Shotwell two skulls of singular form. A Mr. Clark was with Mr. Carley when I left the relics with the Antiquarian Society.

“(Signed) C. P. GRIDLEY.”

The second reply is as follows :

“SPRINGFIELD, Clark Co., O., Feb. 8, 1883.

“DEAR SIR:—In answer to your request I would say that it was over the center of the mound that I found these relics, and over the bed of charcoal of this form lying north and south 4x10 feet. (Signed) C. P. GRIDLEY.”

Thus the location of the finding this measure stone was at a depth of about 26 feet below the top of the ancient mound, and at or near its center, and the location of the find saves the relic from any presumption of its belonging to a later, or what we call *intrusive* deposit. As described by Dr. Drake, this mound measured 440 feet in circumference. A reference for the history of the removal of this mound, and for all that is to be gleaned as describing it, and the finding of the “Gest Tablet” is made to a pamphlet entitled, “The Prehistoric Remains Which Were Found on the Site of the City of Cincinnati, O., with a Vindication of the Cincinnati (Gest) Tablet,” published by Robert Clarke, Esq., in 1876. The “Gest Tablet,” which must always hereafter be associated with the “Gridley Measure,” was, as per the descriptions in Mr. Clarke’s valuable pamphlet, found at the center of the mound and about 4 feet above its base, so that the places of deposit of the two stones must have been very near the one to the other.

Mr. Gridley having referred to Mr. S. T. Carley, who was a member of the Western Academy of Natural Sciences, and afterwards a member of the Cincinnati Society of Natural History, I ascertained that Mr. Carley was a resident of Mount Holly, Clermont County, Ohio, and wrote him touching these matters. I received from him in reply the two notes following :

“MT. HOLLY, Feb. 4, 1883.

“DEAR SIR:—Yours of January 31st received. I remember the circumstance of Mr. Gridley’s depositing in the collection of the Western Academy of N. S. a number of specimens of Indian relics subject to his demand. They were all labeled with his name. If the stone you allude to has his name attached to it, it is undoubtedly one of the lot he deposited at that time” (about thirty years ago). “At the time the Academy collection was transferred to



he Society of N. H. , nothing had been heard of Mr. Gridley for many years, so the specimens were thought of only as part of the collection. If Mr. Gridley should claim them, I have no doubt but the Society of Natural History will do what is right and just in the case. If the stone is of any special value, it will be worth more in a general collection than it could be in the hands of any single individual.

Respectfully,

“(Signed)

S. T. CARLEY.”

“ *Mt. Holly, Feb. 9, 1883.*

“DEAR SIR :—It is with pleasure I acknowledge yours of the 5th, as it enables me to understand your purpose. Such a book as is referred to by Mr. Gridley” (the ‘antiquarian book’) “does not exist, but the records of the Academy of N H. ought to contain an account of the transaction with Mr. Gridley, which must have occurred about the time you mention (’41). I remember the circumstances of the transaction distinctly, and I also remember the particular stone referred to. Mr. Gridley was in the habit of showing me his findings from the Fifth street mound, so I feel sure the specimens deposited in the collection by him were found in that mound. Mr. Gridley could have had no motive to deceive any one in regard to the place where the stone was found. Besides, he was too honest to have done so. I know he went very often to the mound in search of relics, and I sometimes went there with him, but I never found any implements, but I once found three human skeletons, each lying on the back, extended, and the skulls of all three were crushed in from back to front, which I consider an unusual and interesting fact.

“ Respectfully yours, ”

“(Signed)

S. T. CARLEY.”

*Fig. X.*

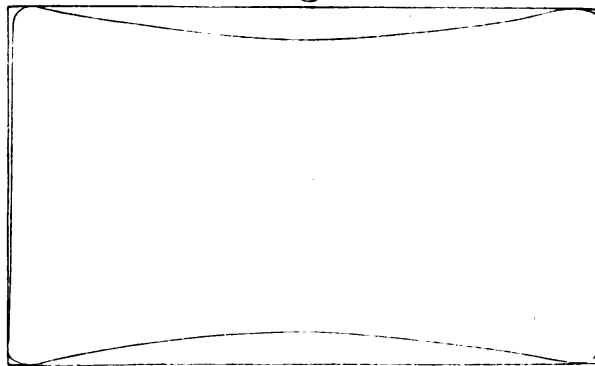

With this history of the Gridley Measure, we give Figure X, the actual measures of the Gest Tablet, *reduced to half size*, taken from the slab itself, as referred by try squares to a perfect rectangle. By calipers the measures of the stone are as follows; Extreme length 4.96-7 inches. Greatest width 2.99 inches. Least width 2.50 inches. Corrected by being referred to a perfect rectangle, its measures are: Extreme length exactly 5 inches. Greatest width 2.99 inches; least width 2.50 inches. Chord of shallow arc on each side 4.50 inches.

Since writing the foregoing, my attention has been called by Dr. Hunt, President of the Society of Natural History, to an article in the May number, 1843, of the "*American Pioneer*," published in Cincinnati. This article describes and figures the Gest tablet and the Gridley relics, those referred to in his letter above, which include the "*measuring stone*," the subject of our main article. It speaks of "Figure 1" (the Gest Tablet) as a carved stone, found at the bottom, and near the center of an ancient mound, "now being removed from Mound street, near Fifth, this city." The mound is described as about 25 feet high. From the place where this was found, "about ten feet distant in the mound, and nearly on the same level, were found parts of another skeleton, with a beautiful stone ornament four inches long, two inches wide, and nearly an inch thick (figured), also a stone instrument nine inches long and three wide (figured), this is about a fourth of an inch thick. The long, straight side has a diamond-shaped edge, as if it had been used for dressing leather. These (with others described) were discovered by and are in possession of Mr. Gridley of Longworth street." The article says the Gest Tablet was taken from the mound in 1841, and this, with Mr. Gridley's statement, fixes the date of the find of the "measuring stone."

#### APPENDIX B.

The following quotations are made from the Smithsonian Report of the Ancient Monuments of the Mississippi Valley, to establish as far as possible the facts: (1) Of care and accuracy in the measures of the mounds; (2) Of identities and correlations of groups and measures, such as to prove in the minds of the surveyors the possession by the Mound Builders of a standard of measure, and some means of taking angles correctly; also a scientific and

religious object in the construction of the works, and (3) Of a further proof of the correctness of the measures as surveyed.

As to taking and reporting the exact measures of the various works :

“ Indeed, no exertion was spared to insure entire accuracy, and compass, line and rule were alone relied upon in all matters where an approximate estimate might lead to erroneous conclusions.” Introduction, page 34.

“ These plans are all drawn from actual and minute, and in most instances personal survey, and are presented, unless otherwise specially noted, on a uniform scale of 500 feet to the inch. When there are interesting features, too minute to be satisfactorily indicated on so small a scale enlarged plans have been adopted. Sections and supplementary plans are given whenever it is supposed they may illustrate the description or assist the comprehension of the reader. The greatest care has in all cases been taken to secure perfect fidelity in all essential particulars.” (Page 10.)

“ To put all skepticism at rest, which might otherwise arise as to the regularity of the works, it should be stated that they were all carefully surveyed by the authors in person. Of course no difficulty existed in determining the perfect regularity of the squares. The method of procedure in respect to the circles was as follows : Flags were raised at regular and convenient intervals upon the embankments, representing stations. The compass was then placed alternately at these stations, and the bearing of the next flag ascertained. If the angles thus determined proved to be coincident, the regularity of the work was placed beyond doubt.” (Page 57.)

“ The square or rectangular works attending these large circles are of various dimensions. It has been observed, however, that certain groups are marked by a great uniformity of size. Five or six of these are noticed in the succeeding pages ; they are exact squares, each measuring 1080 feet to the side, a coincidence which could not possibly be accidental, and which must possess some significance. It certainly establishes the fact of some *standard of measure* among the ancient people, if not the possession of some means of determining angles.” (Page 48.)

As to the plan of the Newark Works, on foot note to page 71 :  
“ A number of plans of these works, as well as of those at Marietta,

have been published ; but they are all very defective, and fail to convey an accurate conception of the group. The map here given is from an original and very careful and minute survey made in 1836 by Charles Whittelsey, Esq., Topographical Engineer of the State of Ohio, corrected and verified by careful re-surveys and admeasurements by the authors. It may be relied on as strictly correct." A similar explanation is made on "page 73" as to the plan of the Marietta Works.

But apart from these statements of exactitude, there is a proof of it to be had from the measures themselves. The works consist of groups, in some instances separated from each other by many miles, yet on the compilation from the field notes it soon became manifest from the surveys that there was identity of groups and measures as stated. Thus besides the care taken in the admeasurements of individual groups, justification was found in the agreement of measures of these with other and similar groups, upon which equal care had been bestowed. This statement is made by the authors.

As to the coincidences of measures :

"It is not to be supposed that these numerous coincidences are the result of accident." (Page 71.) "Although in the progress of investigation singular coincidences were observed between these works, yet there was at the time no suspicion of the identity which subsequent comparison has shown to exist." (Page 56.) Again : "There is one deduction to be drawn from the fact that the figures entering into these works are of uniform dimensions, which is of considerable importance in its bearing upon the state of knowledge among the people who erected them. It is that the builder possessed a standard of measure, and had some means of determining angles. \* \* The coincidences observable between them could not have been the result of accident, and it is very manifest that they (the works) were erected for common purpose. What the purposes were the reader must judge. Without entering into any argument upon the subject, we may content ourselves with the simple expression of opinion that they were in some manner connected with the superstitions of the builders" (Page 62). As to a *unique* work in Seal Township, Pike County, Ohio, they say : "It is impossible to resist the conviction that some significance attaches to these singular forms." (Page 67). As to the Portsmouth works they say : "Whatever may have been the divinity of their belief, order, symmetry and design were among his attributes; if, as ap-

pears most likely, the works that most strongly exhibit these features were dedicated to religious purposes, and were symbolical in their design." (Page 82). As to the works in Montgomery County, Ohio: "It tends to confirm the impression produced by the other works that some significance attaches to the combination of the two circles and the square." (Page 83). As to the Newark works: "Several extraordinary coincidences are exhibited between the details of these works and some of those already described. The smaller circle F is nearly identical in size with that belonging to the "Hopeton Works," and with the one attached to the octagon in the High Bank group. (See plates xvi. and xvii). The works last named are situated upon the Scioto, seventy miles distant. The square has also the same area with the rectangle belonging to the Hopeton, and with the octagon attached to the High Bank works. The octagon, too, has the same area with the large irregular square at Marietta. The small circles, G, G, G, betray a coincidence with the works above mentioned, which ought not to be overlooked. It is not to be supposed that these numerous coincidences are the result of accident." (Page 71). So on page 66 they say: "It will be remarked that we have here the square, the circle, and the ellipse, separate and in combination, all of them constructed with geometric accuracy."

We have still another series of measures which go far to confirm the accuracy as to those given of the groups of works quoted. Many of the tumuli covered *altars*, so called, located generally on the ground level, and at the center of the mounds in which they were respectively built. These altars were curiously constructed. The shape was first marked out, and a portion of ground dug out to the depth required. This space was filled with sand, beaten down very compactly. Fire was used upon this until the substance of the altar become solidified to a mass, preserving its shape and substance as of a solid stone. Above this, quite often, another, and sometimes a third altar was constructed, of defined regular shape, followed by the same use. Over these finally the earth was heaped and the mound formed. By this the altar in its integrity would be preserved for any number of years. The measures of some of these altars, as they are stated in the article on "Sacrificial Mounds," commencing with page 144, are as follows: No. 1. A circular base 9 feet, or 108 inches in diameter, diameter of top 3 feet, or

36 inches, depth 9 inches. No. 2. Rectangular base 10 feet, or 120 inches long, 8 feet, or 96 inches broad. Top 6 feet, or 72 inches long, by 4 feet, or 48 inches broad, height 18 inches. No. 3. Square base 10 by 10 feet, top 6 by 6 feet, and a circular bowl in this of 4 feet in diameter. Depth of altar 22 inches, sinking a foot or more below the original surface of the ground. No. 4. Second and upper altar 8 feet by 8 feet." Here, the application of the small measures, in inches and feet, is as natural to us as if these units of measure had been used by the ancient builders, and seems to confirm the measures reported of the large works in the open.

The extreme antiquity of the works is marked by the frail decayed condition of the bony structure of the remains, and this is to be emphasized because of their perfect protection from chemical disintegration and other wear since the time of their deposit. To somewhat illustrate the duration of bony structure: Schlieman, at the Agora, in ancient Mycenae, found the tomb of Agamemnon containing several remains. The bodies had been carefully interred and protected partly by gold masks. "The bones and even the skulls had been preserved; but these latter had suffered so much from the moisture that none of them could be taken out entire." The Trojan war has been estimated at about 1700 B. C., or about 3600 years ago. The remains in the ancient mounds, such as those of the mound in question, are too much reduced to dust for preservation, save the jaw bones and teeth.

[To be Continued.]











*Identification of the British Inch as the Unit of Measure.* 231

From the Journal of the Cincinnati Society of Natural History, January, 1887.

THE IDENTIFICATION OF THE BRITISH INCH AS THE  
UNIT OF MEASURE OF THE MOUND BUILDERS OF  
THE OHIO VALLEY.

---

Continued from page 162.

---

APPENDIX C.

THE "RICHARDSON TABLET" THE "GEST TABLET" AND THE  
"CLARKE TABLET" AS RELATED TO AND CONNECTED WITH THE  
"GRIDLEY MEASURING STONE."

---

*Introductory remarks on the significance of the Richardson and  
Gest tablets.*

These tablets are pictures or ideographs. The pictures are phallic and through the phallic idea give rise to an expression of measures of time, as their chief function. These tablets are of very great archæological value, in the opinion of the writer, as affording a solution by their simple plainness of the much vexed question of the pre-historic intendment of the symbol of *the cross*. They afford an interpretation of the so frequent cross symbols of Central America; and by this help, these in turn almost assuredly interpret the more obscured Asiatic representations. No one after examining the Richardson Tablet need go astray in assigning a proper causative idea for the use of the emblem of the cross in prayers for rain in Central America. These tablets lead us to a comprehension in an important degree, quite satisfactory, of the Palenque Cross; and that in related connection with the old Mexican hieroglyphical manuscript cross of the M. de Ferjèrvàry manuscript at Budapesth Hungary, pictured in volume 22 of the Smithsonian Contributions to Knowledge. In this last the tree of life rises out of the yoni; under another meaning of the same symbolism life rising out of death; and this is part of the significance of the Palenque Cross. Having obtained a clear idea to some extent, of the symbolic interpretation of these, we become reassured as to a like significance attaching to the yoni and lingham symbols of the Hindus, and especially to the *asheras* or *groves*, as depicted by Dr. Inman in his "Ancient Faiths embodied in Ancient Names." Indeed the phallic creative or generative symbol seems radical as to all systems of religion, ancient and modern, pagan and Hebrew and Christian. So far from being ~~suited~~ to a rational

or philosophical view of the latter, this helps to even a more acceptable comprehension thereof. For in place of looking upon the Hebrew system as springing abruptly out from the world of thought, and the nations, as the first true revelation of a personal God to man, we become informed that this Hebrew system was a legitimate development of a world effort at formulating a mode of religious philosophy; out of material long before accumulated by the pre-semitic Old Babylonians and Egyptians, who can be traced for their origin in Asia to the head of the Persian Gulf and the mouth of the Nile, where the trace is lost, unless it be recovered in Central America, and thence from the Mound Builders. The old and pure ideas conveyed under symbols, became lost, and acceptance of these symbols was made merely for what the eye saw; consequently a degredation to the sensuous, and that inexpressible offensiveness to modern ideas, which so loath any possible connection or relation of such symbols with the high ideals of the teachings of the Hebrew and Christian sacred books. We may look upon the Hebrew religion as contained in the Sacred Text, as recognizing this ancient symbolic origin as the very source out of which it sprung, and the scaffolding or skeleton on which it was framed. But in doing this it reformed the abuse of gross interpretation and reverted to the true and ancient use of the phallic or nature symbols, as setting forth a mode of exact science, which should lay at the basis of religious worship. Out of natural science or knowledge the development of the true and pure went on evolving out of the ages, culminating in the Christian Dispensation, which to-day actuates the world.

The writer would refer to the very sensible temperate and judicious remarks on phallic pictures made by Mr. Charles Rau in Chap. iv, ("The Group of the Cross.") of his article on the Palenque Tablet, published in volume 22 of the Smithsonian Contributions spoken of; two of which it seems well to quote:

(a) "However, it will be evident to every one who has the faculty of divesting himself for a time from now prevailing ideas that the mysteries of generation must have powerfully acted upon the imagination of men in earlier ages, and must have led, in consequence of a tendency characteristic of a certain stage in human development, to the symbolization of that life-giving and life continuing agency. In the course of time the meaning of the emblem

became modified, though it always appears to relate in some sense to the creative energy of nature.”

That which proves Mr. Rau to be right is the fact that, among other things, the technical terms for these real images with the Hebrews, became in after times, and are to-day made use of in modern languages, to convey a modified and spiritual, in place of a real, significance.\* Again :

(b) “The pudency of Christian nations of our time is by no means an innate quality, but simply the result of long-continued training.”

This remark also is true. No one can carefully study the reach of phallic symbolization without, somewhat to his amazement, finding that one of the chief places for discovering multitudes of representations derived directly from it is in church ornamentation and dress. It seems the place especially devoted to this mode, slightly, and only slightly, obscured. The writer is led to make this comment from the idea that, though the remark of Mr. Rau is true in itself, Mr. Rau seems to have labored under a common misapprehension in making it, viz., that of attributing to the origin of the symbol, and its use, a gross, sensual, and truly degrading, because merely animal and sexual, conception. The writer considers that the use of the symbol was conceived of in the utmost purity of thought, as the very basis and radix of all the religious systems of worship, and of all theosophic philosophy, which the better world has ever possessed.

He would also call attention to a remarkable fact connected with the phallic literature. While the cross-bones and skull have ever been taken as emblems of mortality, the grave, and decay, they have been also taken as the emblems of femininity and its generative functions. In Hindoo representations, the skull and cross bones are placed over the pudenda, or door of life. The mountain top, gilded with light, presents the same type when con-

NOTE.—For an illustrative instance: The Hebrew Jehovah, in the most solemn passage of Exodus, gives his name as SaCR, which word means, in its first and essential signification, *membrum virile*. From the signification the word, passing over to the secondary meaning of *male-victim*, through the offering of which the Deity was *memorialized*, hence took the derived signification of “*memorial*.” “The making of, or placing the SaCR, or *memorial*, before the Lord,” was handed down, *idem sonans*, among the nations, and with the Roman priest became “SaCR-*facere*,” or afterward, with the English-speaking race, SaCR-*ficere*; thus showing that the latest modern usage points back to the ancient phallic usage as its essential element. To this can be added: The word *cherub* is, in Hebrew, a *participle* from the word CRB, the participle being CRUB (*cherub*). For the initial C use its kindred form SC, and we have SCRB, which, with the proper vowel and the Greek termination, gives us SCaRaB-*eus*, the *scarabeus*, or Egyptian beetle, emblem of divinity. The Egyptian hieroglyphical meaning of the *winged beetle* was, especially, *the flight of lunar time*; being sacred to the moon (Seyffarth); because of the moon's supposed generative influence.

trasted with glooms of deep recesses or valleys. While the phallus represented life giving or bearing energy, and the yoni passive receptivity, the contrasting ideas were paralleled with those of life and death. The woman represented the door of darkness or evening, into which the sun descended as into its grave, but out of which the new-born sun arose, or Horus was born of Osiris and Isis. With all her qualities of loveliness, fascination, and attraction, she was, by force of certain similes, represented as the insatiable monster craving for and swallowing up all life, and hence her extreme emblem, Death, or the Dragon, or most horrid monster of destruction. To quote the language of the Church, she was—" *Arma diaboli, via iniquitatis, scorpionis percussio, nocivum genus, sepulchri titulus.*" In this phase she was the type of death and destruction, hateful and devouring. In the Palenque Tablet and the Ferjèrvàry picture the phallus raises out of the yoni, which in turn rests upon the head of a devouring monster, or of a skull; either of which answers for the appropriate symbol intended.

#### THE RICHARDSON TABLET.

(See Figure xi.)

This Mound Builder relic was found by Mr. J. M. Richardson on the 31st day of January, 1879, in excavating a mound on the road leading from Wilmington, Ohio, to Harveysburg, known as the Wilmington and Waynesville Pike, about three and one-half miles from Wilmington. The bones with which the relic was found were decayed to a lime-like dust, but the teeth were yet preserved. The history of this find is contained in a pamphlet entitled "An Illustrated Description of Pre-historic Relics found near Wilmington, Ohio," published in 1879, by Dr. L. B. Welch and J. M. Richardson. This account was copied into the *American Antiquarian*, in the October number, 1881. The writer thinks there can be no doubt as to the genuineness of the Richardson Tablet. It is formed after the same general plan with the Gest Tablet, and serves to explain and interpret the latter. In it the picture is so plain that there can be no mistaking the key-fact intended to be displayed. Figure xi is a very exact reproduction of the tablet.

The picture is formed on a representation of the phallus, with testes, in the form of an inverted *Tau* cross. The testes form the base or bar of the cross. The left testis, as one looks at the repre-



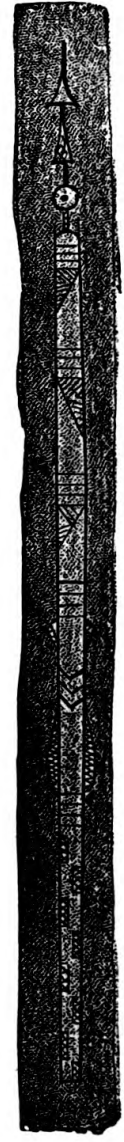

FIGURE II.—THE WILMINGTON TABLET.

sentation, has the form of the male human head, male because of the chin-beard, the right one has the form of a female human head, female because of the side locks or curls. Thus under this form *man* and *woman*, or male female, is represented in one figure. So, also, from the general character of the tablet, the male head, with its abundance of hair, represents the *sun*, heat, and dryness, or earth, while the female head represents the *moon*, coolness, and moisture, or water. The male expresses active vitalizing energy, the female expresses passive receptivity. A strand of hair from the male head distinctly lines out the body or shaft of the phallus, and doing so turns and then returns on a line parallel to the first, back to the head. From the space occupied by the female head a line extends up vertically through the length of the phallus, and issues out of its summit in *waves of water* to the right and left, forming the expanse of the firmament. The space intermediate between the testes or bar and the heavens is divided into four quarters. In the first, on the female side, and next to the head, is to be found a shape like the crescent new moon. In the second, or the next above and on the same side, is a shape as of the full moon. In the third, on the opposite side at the top, is to be found a shape as of the moon in her third quarter. And finally, in the fourth, or in the compartment next to the male head, is to be found no moon at all, or the dead quarter. It will be observed that the quarter next to the male head contains a great quantity of its hair, a fractional portion of which extends up into the quarter above. The opposite quarter next to the head of the woman contains the rough outlines of a duck. The quarter above this shows a dead, leafless branch; while the opposite quarter at the top has, beside the strand of hair, a patch like a garden, and also waved curved lines as perhaps of wind. It would thus seem that beside the four quarters of the moon the slab is intended to represent the four seasons of the year. Spring, with the germinating heat rays and garden patch, summer heats by the mass of hair or rays of the sun, autumn by the duck, and winter by the leafless branch. It seems, moreover, that the figure in the summer quarter formed by the strands of hair is intended rudely to show the head of the goat sucker inverted, with its wide mouth and very short beak, the mouth wide open, as it is to be seen in the summer heats when catching insects. This bird, or, as it is commonly called, the bull-bird, has very few species or varieties; it is almost alone, exceedingly characteristic, and markedly a bird of the summer heats.



The tablet has some very peculiar number markings at the top, set, one part to one side, and on the lower part, to the left as you look at it, of the upper line, and one part to the other side and on the upper part, to the right as you look at it, of a lower line. Commencing in the center, and counting as we proceed toward the left, the *spaces* are 1, 2, 3, 4, 5, 6, 7, 8, 9 and 10, or ten spaces, while the *projections* between the spaces are 1, 2, 3, 4, 5, 6, 7, 8 and 9, or nine projections. On the other side, counting as we proceed from the center to the right on the lower line, we have 1, 2, 3, 4, 5, 6, 7, 8, 9 and 10, or ten spaces to the turn of the row of spaces and projections downward on the side, then there are two more spaces down the side, or 11 and 12, thus making a separation of the 12 spaces into 10 spaces and 2 spaces. By a like counting the protuberances are 1, 2, 3, 4, 5, 6, 7, 8 and 9, or nine protuberances, distinctly to the turn at the corner down the side, then two more, or 10 and 11, making eleven protuberances separated into 9 and 2. The description of spaces and protuberances is conventional, for they may be taken either way, with the same numerical results. By this, we have *two sums*, which added give 18, and multiplied give 81: also 9 and 12 which added give 21, the reverse of 12, and multiplied give 108: also, 9 and 11, which added give 20: also  $9+10=19$ , and  $11+12=23$ . The sum of these is 42, and their difference 6, and so on.

This tablet is of Waverly sand stone  $3\frac{1}{8}$  inches wide,  $4\frac{1}{8}$  inches long and  $\frac{5}{8}$  inch thick. The reverse is unmarked save by 5 deep and 3 shallow grooves. It will at once be seen that the number forms which the markings are capable of forming, are singularly a repetition of the type measures, so much used in Mound Builder construction in the Ohio Valleys. Around the edge of the tablet, making of it an embracing cartouche, is to be found a long curiously wrought and armed arrow, or dart; and because of resemblance the writer is tempted to call attention to the Mexican ideograph or symbol of *Itz-co-atl*, or "Obsidian Serpent," pictured in Mr. Rau's Contribution in volume 22, of the Smithsonian Contributions, on page 51, as also to the explanatory text.

#### THE GEST TABLET.

(See Figure xii.)

This tablet is so remarkable as a work of advanced art that it can be ranked with those of Palenque and Copan. Examined carefully with those and it presents a likeness of artistic culture, a

*Identification of the British Inch as the Unit of Measure.* 237

sameness. So, too, it presents the same features which Mr. Rau notices as to the Palenque productions. He says: "Any one who examines the representation of the Smithsonian tablet will be struck with the want of symmetry of its sculptures and its incorrect (artistically) outline. \* This asymmetrical appearance of the slab, is not at all owing to its restoration, as might be imagined at first sight, but simply to a lack of precision on the part of the sculptor. \* \* Though the bas relief figures on it show a commendable finish, the total aspect of the sculpture is not that of a well executed work, at least not in our sense. The Palenque Cross shows some incongruities in the proportions of its parts, and the glyphic signs and ornaments, are not disposed in an absolutely harmonious order. \* \* \* The absence of accurateness in the execution of details observable at Palenque did not escape Morelet's critical judgment. 'The ruins of Palenque' he says 'have been perhaps too much eulogized. They are magnificent certainly in their antique boldness and strength, but I must say, without contesting their architectural merit, that they do not justify, in their details, all the enthusiasm of archæologists. The ornamental lines are wanting in regularity, the drawings in (modern artistic) symmetry, and the sculpture in finish.'" The artist had all the mental conceptions, but he lacked the perfect skill of the later Greek, or of our day, for the artistic perfection of his work. The work was "irregularly regular" to quote the apt expression of Mr. Gest; and so peculiarly so, as to confirm its genuineness. Perhaps the chief reason of all this was the lack of adequate instruments for working in hard stone. "Instruments of flint, or some other hard stone were much better suited for that purpose," says Mr. Rau, speaking of the obduracy of the stone of the Palenque Tablet. And, indeed, stone chisels were all the Mound Builders could have had for working the Gest tablet. Mr. Rau describes the tablet of the Palenque Cross as being  $3\frac{1}{4}$  inches thick, and consisting of a hard fine grained sand-stone of yellowish gray color; the relief of the sculpture being  $\frac{3}{8}$  of an inch.

As to material, the Gridley measure is likewise a hard fine grained sand-stone of yellowish gray color,  $\frac{1}{2}$ ths of an inch thick. The Gest tablet answers, for material, also to this description, though the grain of the stone may be a trifle coarser than that of the Gridley measure. The Gest tablet is  $\frac{5}{8}$ ths of an inch thick, and the relief of the sculpture is  $\frac{2}{8}$ ths of an inch, distinctly de-

fined even in detail, but not sharply. Had this tablet been found at Palenque it would have been taken as belonging to the Palenque material and style and culture.

On comparison, the general resemblance of the Richardson and Gest tablets will be at once seen. The Gest tablet, Figure xii like the Richardson, has the phallus and testes as the base of its representation, in the form of an inverted *Tau* cross. In place of the human heads for the testes those in the Gest tablet are represented by the labyrinths of ducts belonging to the organ, with a seed vesicle in the midst. These labyrinths unite by a ligament which continued forms the shaft of the phallus. At the summit a waved line or bar projects either way, in place of, and for, the waves of water in the Richardson slab. In the body of the phallus the seed vesicles are represented as developed to the stage of *embryo foetuses*, and these again, are projected forth, or over to the sides, and are represented as in a further stage, viz., that of *four weeks* growth, or 28 days. This is shown in Figure xiii by the sketch

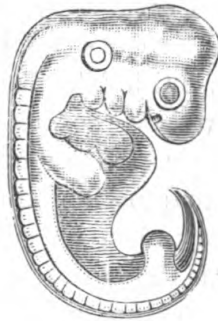

Figure xiii

of that period of development taken from a medical work. These projected foetuses are four in number, two on each side of the shaft, and are made to occupy the four quarters of the divided space, one to the quarter, in a similar manner with the occupancy of the like quarters, or compartments, on the Richardson slab, by the phases of the moon and the seasons of the year. It will be seen that the positions occupied by the foetuses, or the *men*, are always by contrast *reversed*.\* From the fact that the male or-

NOTE.—This reversal is evidently to signify the *double sex*. The same thing held in Hebrew esoterism,—for, the word for “*man*” contained the numbers 113 (diameter to a circumference of 355), the lunar year in days, whereas the word, or name, “*The-woman*” contained as the sum of its numbers 311, or the *reverse* of “*man*”:—the two, together, as 113–311, being the division or unfolding of the number 226, which last was the sum of the numbers of the letters of the Hebrew expression *Y’sod Olam*, or “*mystery of creation*”, which was the name given to the location of the number 9 on the genitals of the *cosmic man* of Cabbalah (Ginsburg).



FIGURE 12.—THE CININNATI TABLET.



gan is made to show the office or function of the womb, the whole emblem is androgyne; nor does there seem to be any distinctive mark of sex, or unequal power, or quality, used either on the right or left of the shaft, save the reversal of position.

This slab like the Richardson, has number markings, distinct and clear. At the base of the Tau cross there are 6 distinct spaces and 7 lines, the spaces being broad. Beneath this and on the edge of the stone are 23 distinct, but small, spaces and 24 lines. The position of these 23 spaces is such that groups of them seem to be marked by the lines of the larger spacing, viz., 3, 7, 13, and 20. At the top there are similar markings, viz., 7 spaces and 8 lines, and 24 small spaces and 25 lines. In these the groupings are: 13, emphasized, and 20. In the whole sculpture there are 16 round dots or small circles, of which two are in the testes. In the body of the phallus there are 4, and continuing the count over, toward the right and left, respectively, we have 5 additional on each side, making a count of 9 and 9.

For the broad spacing and lines we have  $6+7=13$ , and  $7+8=15$ , together 28; and 13, the number of Catamenia in the year, multiplied by 28 equal 364, or the week year, while  $28 \times 15 = 280 + 140 = 420$ . Of this 280 days is 40 weeks or the period of parturition, while 420 is  $210 \times 2$ , and 210 days is called the period of *viability*. So, also,  $6 \times 7 = 42$ , or  $21 \times 2$ , and the reverse of 21 is 12. Or, these spaces and lines being 6, 7, 7, and 8, are together equal to  $7 \times 4 = 28$ . The smaller spacing and lines give us  $23 + 24 = 47$ , with  $24 + 25 = 49$ , or together 96 (or  $24 \times 4$ , or  $12 \times 8$ ).

Thus we have the exact description of these tablets. The numbers shown on these are familiar as those used in the measures of the Mound Builder works in which the tablets were found; also as periods of lunar and solar time, and especially lunar time, as marking the natural periods of menstruation, quickening, viability, and gestation. The relationship becomes closer when we find that the Gest Tablet, as to its size, has special measures from the same unit or standard with the Gridley stone; they are: length, 5 inches; least breadth, 2.50 inches; greatest breadth, 3 (2.99) inches, with two chords of 4.50 inches each.

## THE CLARKE TABLET.

(See Figure xiv.)

Another and very late *find* is fortunate, timely, and of great value, as confirming the genuineness of the Richardson and Gest Tablets. It is what is to be known as the "Clarke" (or Waverly) "Tablet," now the property of Mr. Robert Clarke, of Cincinnati. It is presented in Fig. xiv. On the left side, as one looks at it, are to be seen the unmistakable *fac-similes* of the foetus images of the Gest Tablet, while on turning the plate, so as to have the top on the right hand and side, the presentation exhibits the *fac-similes* of the involved duct labyrinths of the *testes* in the same tablet. In this, however, the shaft seems to be changed to represent the yoni.

This tablet was discovered March 12, 1885, by Mr. J. P. MacLean, in the collection of Dr. W. R. Hurst, of Piketon, Ohio, was obtained of him and disposed of to Mr. Clarke. The tablet was broken in two pieces, which Mr. MacLean found, piece by piece, in the collection. The history of the tablet, as given by Dr. Hurst to Mr. MacLean, is as follows: "The tablet was taken from a mound on the farm of Abraham Cutlip, about one mile south of Waverly and about three and one-half miles north of Piketon, about March, 1872. It was found about three feet from the bottom of the mound, on the north side, by Abraham Cutlip and David Allen, who were cutting away the mound. Dr. Hurst obtained it from them while they were at work. The mound was on the second bottom of the river, had been fifteen to twenty feet high, but had from time to time been cut away, so that it was only about ten feet high at the time of this excavation. The mound was composed of clay. With the tablet were found 'darts, badges, and human bones.'"

There can be no doubt of its genuineness, and for this reason it is of very great value as corroborative of not only the authenticity, but also the reading of the Gest and Richardson Tablets.

If we now refer to the Gest Tablet for comparison, we will find that it is, in its main or essential features, the same with the Palenque Cross and the Ferjervary picture. In all cases we have the tree of life, with a human being (Androgyne) standing upon either side. In the Ferjervary picture the phallus rising out of the yoni, has seven branches on each side; the phallus at the top bifurcating into two branches (for water waves), extending out on



FIGURE 14.—THE WAVERLY TABLET.





either side, and these, again, are separated into further subdivisions, etc. In its frame, on the three sides thereof, we have for markings 3 twelves, or 36 in all, distinctly done. By reference, for similar pictures for similar showings, on the Asiatic Continent, to Dr. Inman's "Ancient Faiths embodied in Ancient Names," we will find identity of design. (See his illustrations in Vol. I. on the cover, and on pages 156 and 160, with his explanations.) In these illustrations notice the numbers of bunches of *flowers* to mark the catamenia, so arranged as to make 13 by a count of 6 plus 7, also the numbers 18 and 21. He himself notices the number 13. "This number suggests an explanation. At every lunar period the female has an affection which by its regularity has received the name of menses, or Catamenia, and there are 13 of these periods in the year." Notice also, in Vol. II., p. 648, the phallic and yoni symbols of the Christian Church. One of these represents a monk so marked as to show a man's head with a fish's body. There are 12 marks forming the fish. He holds a string of beads,  $7 \times 2$  or 14 of which are seen. She, standing in an alcove formed by the sun, the mouth of the vagina (*vesica piscis*), holds a string of beads 13 in number, and so arranged as to count 5 and 6 and 7. The rays of the sun are arranged so that 18 are seen, and these grouped to form 10, 3, and 5. There are two more but covered rays, making 20 in all. In Sharpe's Egypt one will find the tree of life, a woman in the branches pouring water. It is inverted, so that the roots are in place of the branches, the shaft projecting into the ground (Isis). All these refer to a like symbolization. The fact is, that having caught at the root ideas, or natural basis of symbolic language, our literature is full to repletion of scattered fragments, which can be gathered, collected, recognized, and referred to a whole, or perfect ancient mode of communication.

There is remarkable harmony between the number indications on these slabs with the mound measures and the Gridley standard of measure by which the mound works were constructed. But likewise there is such harmony between the measures of time indicated by these numbers and the calendar forms of the Mayas that attention is called to the fact. It is to some extent agreed on that there is connection between the Maya culture and that of the constructors of Palenque and Copan. Reference is now made to "The Maya Chronicle" by D. G. Brinton, M. D., Philadelphia, 1882. He says: "The Mayas had a mathematical turn, and

possessed a developed system of numeration. It counted by *units* and *scores*; in other words it was a *vigesmal* system." The cardinal numbers commenced with *one* and closed with *twenty*. From twenty upward the *scores* are used, as "one to the score equals 21," and so on. Now as to their calendar. Their year was divided into 18 months of 20 days each, or 360 days, to which, to make 365, *five* days called "days without names" were added. "But the calendar was not as simple as this. The days were not counted from 1 to 20, and then beginning at 1 again, and so on, but by periods of 13 days each," the 14th day beginning a new week. "28 of these weeks make 364 days, thus having 1 day to complete the tropical solar year. When the number of these odd days amounted to 13, in other words when 13 years had elapsed, this formed a period which was called 'a *katun* of days'. It will be readily observed by an inspection of the following table, that 4 of these indications, in other words, 52 years, will elapse before a 'year bearer' of the same name and number recommences a year. A cycle of 52 years was thus obtained in a manner almost identical with that of the Aztecs, Torascos, and other nations." "20 days were a month, and 20 years was a cycle *katun*.\* This *katun* was divided into 5 lesser divisions of 4 years each. They also had a *katun* of 24 years. They had a great cycle of  $13 \times 20 = 260$  years, called an *Ahau Katun*, or  $13 \times 24 = 312$  years. The Maya Chronicles make from the earliest time to the coming of the Spaniards 71 *katuns*, which equal either 1420 or 1704 years, according to the *katun* used of 20 or 24 years." It seems quite evident that the great cycle of 312 years was composed of 6 cycles of 52 years each.

The peculiar make up of these calendar data brings out in relief a series of numbers, which are so connected with the Mound Builder system of measures, and the tablets spoken of, that it may at least be suggested of them that they point to a common system of use.  $13 \times 28 = 364$  is the catamenial year, and 28 days would, because of being a catamenial period, be a holy week of 4 periods of 7 days each; the number 7 being "*holy*" because it was the base of so many periods of generative time, as, 28, 126, 210 and 280 days.\* It is thought this conclusion is justified by the showing of the phallic system every where among all nations of antiquity. We have  $6 + 7 = 13$  and  $6 + 7 + 7 + 8 = 28$ , on the Gest tablet. 28 is 4 times 7, and  $52 \times 7 = 364$ , showing a co-ordinating mode of

\*NOTE. It seems remarkable, that this word *Katun* for a small cycle is the same with the Hebrew *katon* or *little*. It is evident that, because the phases of the moon run so co-ordinately with the generative periods, it was supposed to be the *intelligent cause*, and was therefore worshiped.

counting time, especially in the priestly or sacerdotal way, founded on the idea of phallic creative growth by periods of 7, viz.,  $4 \times 7 = 28$ , of *menses*,  $7 \times 18 = 126$ , of *quickenings*,  $30 \times 7 = 210$ , of *viability*, and  $40 \times 7$  (or  $28 \times 10$ )  $= 280$ , of *gestation*, and  $52 \times 7 = 364$ , the holy, or week year. So, also, in the great characteristic measures of the Mound works, viz., 1050 and 1080, we find a mode of the use of a year cycle founded on  $52 \times 6 = 312$ , for,  $105 + 108 = 213$ , which is the reverse of 312 and indicates it by the Mound Builder custom of reversed numbers, and again, 213 of itself is 6 times 355 the numerical value of the lunar year in days.  $355 \times 6 = 213$ , and 312 is a great cycle of  $52 \times 6$ .

The writer considers himself very fortunate to be able to close this paper with a fact of discovery in Yucatan, by Dr. Augustus Le Plongeon and his estimable and brave wife, of Brooklyn, New York. When they made the remarkable discovery of the sepulchre of the royal Kan Coh, at Chichen-Itza, they found therein a great number of personal ornaments. These consisted of worked arrow and spear heads, of fine quartz and serpentine, with shell beads, and extraordinary ornaments in jade, of marvelous polish. The point of great interest as to these is this, that though the Mayas had arrived to the great advance in civilization of splendid stone cutting and mason work and sculpture, with an elaborate hieroglyphical alphabet—an advance parallel to that of the old Egyptians and Babylonians—yet their articles of personal ornamentation *were the same* (of the same kind, material, and design) *with those of the Mound Builders of the Ohio Valley*. The labors of Dr. and Mrs. Plongeon in Central America are the most valuable of all others, and their results are so surprising, and so promising of the discovery of “*missing links*,” that they should be furnished with material efficient support by the Government in the further prosecution of this wonderful field of their self-sacrificing personal investigation.

J. RALSTON SKINNER.

NOTE. *Erratum.* In a note to a former article 5011506 is said to be the square root of 51215, whereas it should be 251152.





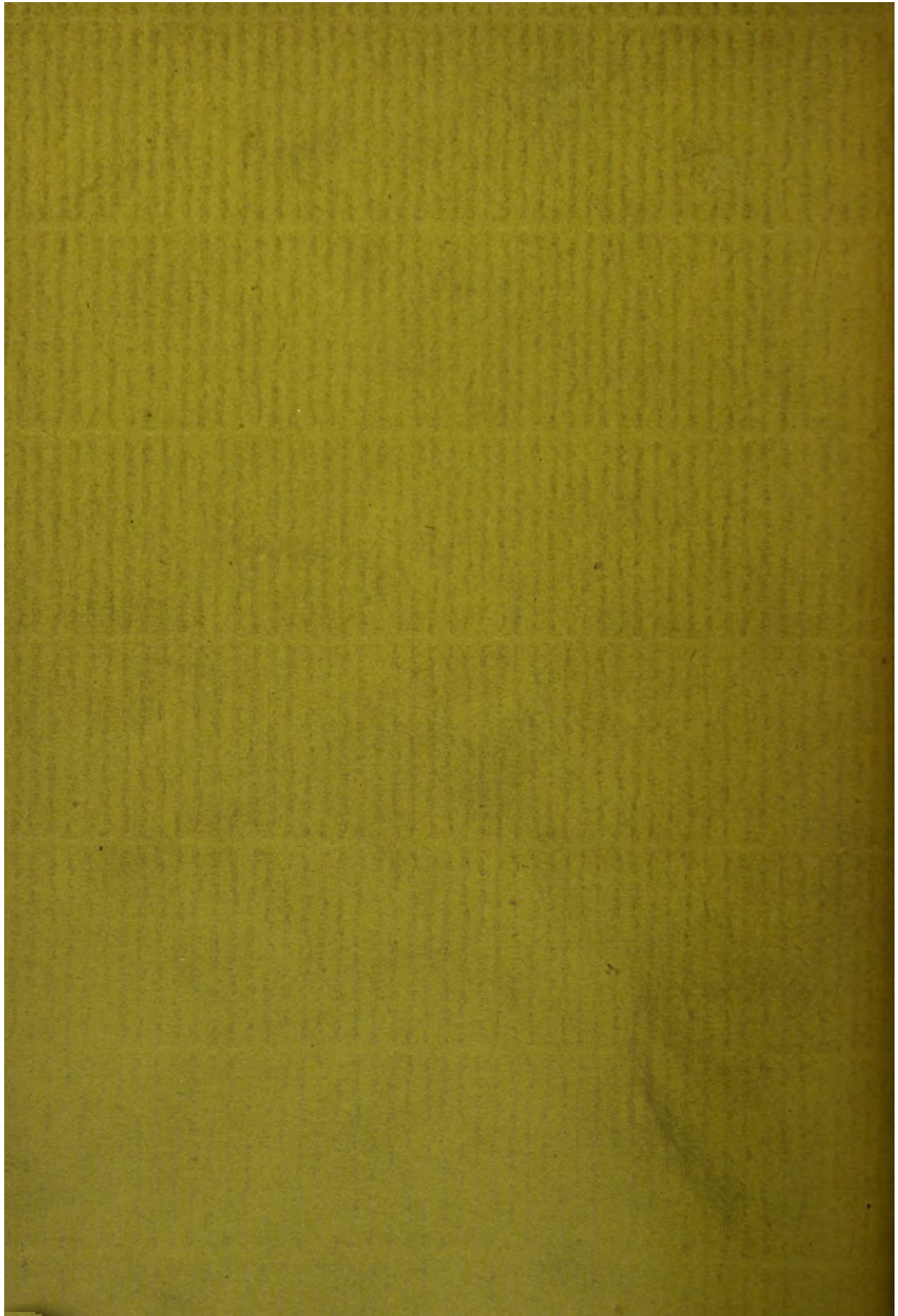





**AFR.N.E. Sk 35**

Bro. J. Ralston Skinner and the Gre

**Tozzer Library**

AWX6635



3 2044 043 274 323

**This book is not to be  
taken from the Library**

Digitized by **Google**

Original from  
**HARVARD UNIVERSITY**

