

Plant response as a means of physiological investigation, by Jagadis Chunder Bose.

Bose, Jagadis Chandra, Sir, 1858-1937.
London, Longmans, Green, 1906.

<http://hdl.handle.net/2027/nyp.33433007351111>

HathiTrust



www.hathitrust.org

**Public Domain in the United States,
Google-digitized**

http://www.hathitrust.org/access_use#pd-us-google

We have determined this work to be in the public domain in the United States of America. It may not be in the public domain in other countries. Copies are provided as a preservation service. Particularly outside of the United States, persons receiving copies should make appropriate efforts to determine the copyright status of the work in their country and use the work accordingly. It is possible that current copyright holders, heirs or the estate of the authors of individual portions of the work, such as illustrations or photographs, assert copyrights over these portions. Depending on the nature of subsequent use that is made, additional rights may need to be obtained independently of anything we can address. The digital images and OCR of this work were produced by Google, Inc. (indicated by a watermark on each page in the PageTurner). Google requests that the images and OCR not be re-hosted, redistributed or used commercially. The images are provided for educational, scholarly, non-commercial purposes.





Digitized by Google

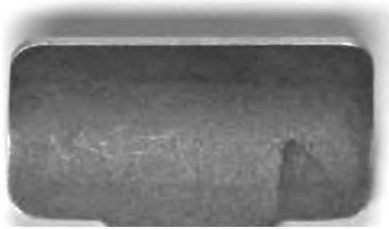

Original from
NEW YORK PUBLIC LIBRARY

PLANT RESPONSE

AS A MEANS OF

PHYSIOLOGICAL INVESTIGATION

+

BY

JAGADIS CHUNDER BOSE, M.A., D.Sc.

PROFESSOR, PRESIDENCY COLLEGE, CALCUTTA

WITH ILLUSTRATIONS

PLANT RESPONSE
JAGADIS CHUNDER BOSE
1906

LONGMANS, GREEN, AND CO.

39 PATERNOSTER ROW, LONDON

NEW YORK AND BOMBAY

1906

All rights reserved



मात्रे

1120
1121
1122
1123
1124
1125
1126
1127
1128
1129
1130
1131
1132
1133
1134
1135
1136
1137
1138
1139
1140
1141
1142
1143
1144
1145
1146
1147
1148
1149
1150
1151
1152
1153
1154
1155
1156
1157
1158
1159
1160
1161
1162
1163
1164
1165
1166
1167
1168
1169
1170
1171
1172
1173
1174
1175
1176
1177
1178
1179
1180
1181
1182
1183
1184
1185
1186
1187
1188
1189
1190
1191
1192
1193
1194
1195
1196
1197
1198
1199
1200

PREFACE

THE investigations described in the present volume have been an outcome of my work on the Similarity of Responsive Phenomena in Inorganic and Living Matter, first communicated as a Memoir to the Science Congress at Paris, in August 1900,¹ and subsequently expanded into greater detail in my book on 'Response in the Living and Non-Living.' The electrical responses described in the Memoir referred to, had been obtained by the method of conductivity variation. The same problem was next attacked by a different mode of investigation, response being now obtained by electromotive variation.² Believing in the continuity of responsive phenomena in the inorganic and organic, I undertook on that occasion to demonstrate by the same method the electrical response of ordinary plants, and to show that every plant, and every organ of every plant, was excitable. It was then generally believed that so-called 'sensitive' plants alone exhibited excitation by electrical response, and the proposition that ordinary plants also showed excitatory electrical response to mechanical stimulation, and that such response was appropriately modified under physiological changes, was much controverted. I have to thank Professor Sidney H. Vines,

¹ 'De la Généralité des Phénomènes Moléculaires produits par l'Electricité sur la Matière Inorganique et sur la Matière Vivante.' (*Travaux du Congrès International de Physique*. Paris, 1900.)

² Paper read before Royal Society, June 6, 1901. Also Friday Evening Discourse, Royal Institution, May 10, 1901.

at that time President, for the facilities which he then afforded me for the full publication of my results in the 'Journal' of the Linnean Society, and for the warm interest which he has manifested in my work, both then and later.

I next undertook to demonstrate that all the important characteristics of the responses exhibited by even the most highly differentiated animal tissues, were also to be found in those of the plant.¹

In my previous investigations I had shown that the tissues even of ordinary plants gave electrical signs of excitatory response. I now undertook an inquiry as to why they should not also exhibit response by mechanical indications; and I was surprised to discover that ordinary plants, usually regarded as insensitive, gave motile responses, which had hitherto passed unnoticed.

From the point of view of its movements a plant may be regarded in either of two ways: in the first place as a mysterious entity, with regard to whose working no law can be definitely predicated, or in the second place, simply as a machine, transforming the energy supplied to it, in ways more or less capable of mechanical explanation. Its movements are apparently so diverse that the former of these hypotheses might well seem to be the only alternative. Light, for example, induces sometimes positive curvature, sometimes negative. Gravitation, again, induces one movement in the root, and the opposite in the shoot. From these and other reactions it would appear as if the organism had been endowed with various specific sensibilities for its own advantage, and that a consistent mechanical explanation of its movements was therefore out of the question. In spite of this, however, I have attempted to show that the plant may nevertheless be regarded as a machine, and that its movements in response to external stimuli, though apparently

¹ Paper read before Royal Society, February 4, 1904.

so various, are ultimately reducible to a fundamental unity of reaction.

This demonstration has been the object of the present work, and not that treatment of known aspects of plant-movements which is to be found detailed together with the history of the subject, in standard books of reference on plant physiology, such as those of Sachs, Pfeffer, Strasburger, Darwin, Francis Darwin, Vines, and Detmer.

In analysing plant-movements the greatest complexity arises from the confusion of effects due to internal energy and external stimulus respectively. I have, however, been able to discriminate the characteristic expressions of these two factors, and thus to disentangle the complex phenomena which result from their combined action. Another very obscure problem is found in the nature of so-called 'spontaneous or autonomous' movements. By the discovery, however, of multiple response, and by the continuity which I have been able to establish, as existing between multiple and autonomous responses, it has been found possible to demonstrate that there are, strictly speaking, no 'spontaneous' movements, those known by this name being really due to external stimulus previously absorbed by the organism. Thus all the experiments have tended to show that the phenomenon of life does not, as such, connote any intrusion into the realm of the organic of a force which would interfere with that law of the Conservation of Energy which is known to hold good in the inorganic world.

The elucidation of the fact that such varied and obscure phenomena in the life-processes of the plant, as, for instance, growth and the ascent of sap, are fundamentally due to the same excitatory reactions as are seen otherwise exemplified in the simple mechanical response now familiar to us, constituted a further result which, at the outset of the investigation, was little to be foreseen.

It has been shown finally that there is no physiological response given by the most highly organised animal tissue that is not also to be met with in the plant. This was proved in detail in the case of the identical polar effects induced in both by electrical currents ; in the conduction of the excitatory impulse to a distance ; in the possibility of detecting the excitatory wave in transit and measuring its rate ; and in the appropriate modification of its velocity by different agencies, even in the case of ordinary plants ; in the passing of multiple into autonomous response in vegetable tissues ; in the light thrown by this phenomenon on the causes of rhythmicity in animal tissues ; in the similar effects of drugs on animal and vegetable tissues, and in the modifications introduced into these effects by the factor of individual 'constitution.' This identity of effects, indeed, as between the responses of plant and animal, is so deep and so extended, that it is to be anticipated that as several of the obscure problems of animal physiology have already been found elucidated by means of these researches carried out on plants, so others will be found capable of explanation by similar means in the near future.

In conclusion, I wish to say that from my assistant, Mr. J. Roy, and my pupils, Messrs. A. C. Basu, S. C. Acharya, S. Chakravarty, N. Roy, and S. Goswami, I have received able assistance at various periods during the course of these long and extended investigations.

J. C. BOSE.

PRESIDENCY COLLEGE, CALCUTTA :

July 1905.

CONTENTS

PART I.—SIMPLE RESPONSE

CHAPTER I

THE PLANT AS A MACHINE

	PAGE
Responsive movements in plants—Work done by plant—Plant as a machine—Indicator-diagrams—Physiological response-curves—Pulse-records—Cardiagrams—Modification of pulse by poison and other agencies—Automatic response in plants—Optical Lever Recorder—Effect of external agencies on automatic pulse-beat in plants	1

CHAPTER II

MECHANICAL RESPONSE TO STIMULUS

Molecular derangement caused by stimulus—Expression in change of form, contraction—Mechanical model—Myograph—Response by differential contraction in pulvinated plant-organs—Longitudinal response in plants—Response of plant to all forms of stimulus—Plant chamber—Practicable forms of graduated stimulus—Electro-thermic stimulator—Stimulation by condenser discharge—Response-recorder—Advantage of counterpoise—Response of <i>Biophytum</i> to thermal stimulation—Response to condenser discharge—Absolute measurements of motile effect and of work performed—Effect of load—Definite determination of threshold of response—Determination of variation of excitability by measurement of minimally effective stimulus	10
---	----

CHAPTER III

ON THE UNIVERSALITY OF SENSITIVENESS IN PLANTS AS DEMONSTRATED BY MEANS OF ELECTRICAL RESPONSE

Arbitrary classification of plants into sensitive and ordinary—Method of electro-motive variation for detecting state of excitation—Hydraulic model—Excitation of vegetable tissue, like that of animal tissue, induces galvanometric negativity—Methods of direct and transmitted excitation—Electrical and mechanical response alike record molecular derangement and recovery—Similarities in simultaneous record of mechanical	
--	--

	PAGE
and electrical response—True excitation has a concomitant negative turgidity-variation, negative mechanical response or fall, and galvanometric negativity—These are true physiological responses, and are abolished at death—Abnormal positive mechanical and electrical responses brought about by positive turgidity-variation—Direct and indirect effects of stimulation—Discrimination of differences of excitability by electric test—Excitability of plant-tissues in general—Responsive power characteristic of matter	29

CHAPTER IV

ON CONDITIONS FAVOURABLE TO THE CONSPICUOUS EXHIBITION OF MECHANICAL RESPONSE

Differences of degree of motile sensibility in sensitive plants so called—Response of anisotropic organ brought about by differential contraction—Production of response by artificial variation of turgidity—Variation and counter-variation of turgescence, causing two opposite responsive movements—Differences between hydrostatic and true excitatory effects—Distinction of plants as ordinary and sensitive, arbitrary—Sensitive plants may be excited, yet give no mechanical response—Certain conditions necessary to exhibition of differential response—Balanced action as result of diffuse stimulus on radial organ—Slight differential contraction of pulvinus magnified by long petiolar index	43
--	----

CHAPTER V

MECHANICAL RESPONSE IN ORDINARY LEAVES

Pulvinoid and pulvinus—Demonstration of mechanical response in ordinary leaves—Response of <i>Artocarpus</i> similar to that of <i>Biophytum</i> —Response to stimulus, even in old tissues, by expulsion of water—Localisation of motile organ in ordinary leaves—Conducting properties of various tissues—Lamina is not the perceptive organ—Response in ordinary leaves, though sluggish, yet comparable in extent to that of <i>Mimosa</i> —Peculiar phenomenon of fatigue-reversal seen in <i>Mimosa</i> observed also in ordinary plants—Periodic reversals	53
---	----

CHAPTER VI

LONGITUDINAL RESPONSE OF RADIAL ORGANS

Absence of lateral response movements in radial organs due to mutually antagonistic effects of equal contractions of diametrically opposite sides—Lateral response in radial stem of Walnut under unilateral stimulation—Also in pistil of <i>Musa</i> —Diffuse stimulation of radial organ causes longitudinal contraction—The 'Kunchangraph'—Longitudinal contraction of stamens of <i>Cyneria</i> not unique—Similar longitudinal responses	
--	--

	PAGE
obtained with stems, roots, tendrils, petioles, stamens, and styles of ordinary plants—Also in fungi—Responsive contraction in <i>Passiflora</i> , comparable in extent with that in <i>Cynerea</i> —Longitudinal response in plants modified by the physiological variations due to age, season, and chemical agencies	66

CHAPTER VII

RESPONSIVE CURVATURE OF MOLECULARLY ANISOTROPIC ORGAN

Molecular anisotropy artificially induced by one-sided cooling—Cooled side less responsive—Diffuse stimulation causes concavity of the uncooled, that being relatively the more excitable—Local fatigue diminishes excitability—Diffuse stimulation now causes concavity of the unstrained side—Similar anisotropy induced in plagiotropic organs, by unilateral action of light—The lower or shaded side of such organs relatively more excitable—Diffuse stimulation causes current of response from lower to upper, and also concavity of lower half—Responses of plagiotropic <i>Cucurbita</i> and <i>Convolvulus</i> —Differences in excitabilities of outer and inner surfaces of tubular organ—Complex response due to successive excitations of two antagonistic halves of an anisotropic organ—Response of spiral tendrils by uncurling—Response in certain cases by contraction of the spiral or curling—Writhing movement in spiral tendril under strong stimulation .	82
---	----

CHAPTER VIII

RELATION BETWEEN STIMULUS AND RESPONSE

Ineffective stimulus becomes effective by repetition—Two types of response in contractile animal tissues, cardiac and skeletal—Response of cardiac muscle on 'all or none' principle; parallel case in <i>Biophytum</i> —In skeletal muscle, increasing stimulus causes increasing response, which tends to reach a limit—Parallel results in longitudinal and electrical response of plants—Effect of superposition of stimuli—Tetanus	94
---	----

PART II.—MODIFICATION OF RESPONSE UNDER VARIOUS CONDITIONS

CHAPTER IX

ON THE UNIFORM, FATIGUE, AND STAIRCASE EFFECTS IN RESPONSE

Uniform response in plants—Staircase effect—Fatigue due to molecular strain—Fatigue in plant-responses—Periodic fatigue—Fatigue under continuous stimulation—Explanation of anomalous erection of leaf of	
---	--

	PAGE
<i>Mimosa</i> under continuous stimulation—Conductivity and excitability of tissue diminished through incomplete protoplasmic recovery—Relatively greater fatigue in a motile than conducting organ—Disappearance of the motile excitability earlier than conductivity—Refractory period—Absence of responsive effect when stimulus falls within refractory period . . .	103

CHAPTER X

THEORIES CONCERNING DIFFERENT TYPES OF RESPONSE

The chemical theory of response—Insufficiency of the theory of assimilation and dissimilation to explain fatigue and staircase effects—Similar responsive effects seen in inorganic substances—Molecular theory—When molecular recovery is complete, responses uniform : when incomplete, fatigue brought about by residual strain—Fatigue under continuous stimulation, in inorganic substance, in plant, and in muscle—Staircase effect brought about by increased molecular mobility : examples seen in inorganic substance, and in living tissues—No sharp line of demarcation in the borderland between physical and chemical phenomena—Molecular changes attended by changes of chemical activity—Unequal molecular strain gives rise to a secondary series of chemical actions—Volta-chemical effect and by-products—Supposition that response always disproportionately larger than stimulus, not justified—Existence of three types : (1) response proportionate to stimulus ; (2) response disproportionately greater than stimulus ; (3) response disproportionately less than stimulus—Instances of stimulus partially held latent : staircase and additive effects ; multiple response ; renewed growth	116
--	-----

CHAPTER XI

EFFECT OF ANÆSTHETICS, POISONS AND OTHER CHEMICAL REAGENTS ON LONGITUDINAL RESPONSE

Response modified by physiological change—Carbonic acid causes depression, and transitory exaltation as after-effect—Gradual abolition of response in hydrogen and restoration by access of air—Chemical agents cause contraction or relaxation of plant-tissue—Effect of alcohol causing temporary exaltation of response followed by depression and protracted period of recovery—Ether causes relaxation and temporary depression of response—Explanation of anomalous action of ether on stimulated <i>Mimosa</i> leaf—Abolition of response by hydrochloric acid—Response restored by timely application of ammonia—Abolition of response by poisonous reagent—Similarity of effect of chemical agents on the response of animal and vegetable tissues	129
---	-----

CHAPTER XII

EFFECT OF TEMPERATURE

	PAGE
Temperatures optimum, maximum, and minimum—Diminution of electrical response by cooling—Temporary or permanent abolition of response due to cold—Characteristic differences exhibited by different species—Mechanical response of <i>Biophytum</i> and autonomous response of <i>Desmodium</i> arrested by cold—Prolongation of latent period—Diminution of longitudinal mechanical response by cold—Diminution of electrical response of plants by rise of temperature—Similar diminution seen in longitudinal mechanical response—Increase of excitability due to cyclic variation of temperature	139

CHAPTER XIII

ON THE DEATH-SPASM IN PLANTS

Difficulty of determining exact moment of death—Various <i>post-mortem</i> symptoms afford no immediate indication—Ideal methods for determination of death-point—Realised in four different ways : (a) Determination by electrical method—(b) Determination by spasmodic lateral movement at moment of death—Experiments with <i>Mimosa</i> —Death-contraction a true physiological response—Continuity of fatigue and death—Death-point earlier in young tissues—Composite spasmodic movement—(b') Determination of death-point in tendril of <i>Passiflora</i> , by sudden movement of uncurling—(c) Determination of death-point by method of volumetric contraction of hollow organ, causing expulsion of contained water	148
--	-----

CHAPTER XIV

THE DETERMINATION OF THE CRITICAL POINT OF DEATH
BY INVERSION OF THE THERMO-MECHANICAL CURVE

Death-spasm in anisotropic organ due to differential longitudinal contraction—In radial organ the death-contraction is purely longitudinal—Death-point determined from point of inversion of a thermo-mechanical curve—The complete record thus constitutes a curve of life-and-death, the two being separated by the death-point—Characteristic thermo-mechanical curve as resultant of variation of temperature and variation of length—The necessity of specifying the rate of rise of temperature—The thermo-mechanical curve characterised by sharp and definite inversion at point of death—No inversion of thermo-mechanical curve after death of plant—Death-contraction under heat-rigor in plant analogous to similar phenomenon in animal—The <i>Morograph</i> , a perfected form of apparatus for determining critical point of death—Remarkable identity of thermo-mechanical curves obtained with two similar specimens—Death-point almost as definite as a physical constant—Vanishing of point of inversion with age—Determination of death-point under cold-rigor—Constancy of death-point	159
---	-----

CHAPTER XV

EFFECT OF VARIOUS AGENCIES ON DEATH-RESPONSE :
THERMOGRAPHS OF REGIONAL DEATH

	PAGE
Lowering of death-point by fatigue—Modification of characteristic thermo-mechanical curve by the action of chemical agents— <i>Comparison-Morograph</i> —Duplication of rigor-point—Death-response a physiological response and not due to coagulation—Death-movements of flowers—Approximate constancy of death-point of florets in a capitulum—Definite interval between death-point and discoloration-point—Translocation of discoloration-point by various agencies—Thermographs of regional death—Thermograph of local fatigue—Thermographic investigation of electrotonic excitation	176

PART III.—EXCITABILITY AND
CONDUCTIVITY

CHAPTER XVI

ON EXCITATORY POLAR EFFECTS OF CURRENTS

Hydro-mechanical theory of excitation in plants—Theory of protoplasmic change—Crucial tests applied by means of polar excitation—Mono-polar and Bi-polar methods of excitation—Advantages of study of polar excitation in plant-tissues as compared with animal—Effects of feeble E.M.F.—Effect of moderately high E.M.F.—Experiments with highly excitable tissues	189
---	-----

CHAPTER XVII

ON CONDITIONS OF REVERSAL OF NORMAL POLAR EFFECTS
IN LIVING TISSUES

Effect of high E.M.F.—Effects at two stages, <i>A</i> and <i>B</i> —Experimental verification of <i>A</i> stage effect—Similar effects seen in protozoa—Experimental verification of complete reversal at <i>B</i> stage—Law of polar effects under high E.M.F.—Investigation on polar effects by death-response—Reversal of polar effects as due to fatigue, or tissue-modification—Investigation of polar effects by glow-response of fireflies	200
---	-----

CHAPTER XVIII

ON CONDUCTIVITY AND EXCITABILITY

Receptive excitability, conductivity, and motile excitability—Molecular Model—Modification of motile excitability : (<i>a</i>) by anaesthetics—(<i>b</i>) by	
--	--

	PAGE
cold—(?) by fatigue—Variation of conductivity : (a) by cold—(b) by rise of temperature—(c) by fatigue—(d) by anæsthetics—Variation of receptive excitability by ether—Conductivity <i>versus</i> excitability—Abolition of motile excitability without abolition of conductivity—Hydro-mechanical theory of transmission of stimulus untenable . . .	216

CHAPTER XIX

ON ELECTROTONUS

The anode acts as a block to the transmission of stimulus—Opposite effect of kathode—Experiments on <i>Biophytum</i> , showing variations of conductivity by anode and kathode respectively—Experiments on <i>Mimosa</i> , showing increase of motile excitability at or near the kathode, and diminution of motile excitability at or near the anode—Curious ‘development’ of response, near the kathode	231
---	-----

CHAPTER XX

ON THE VELOCITY OF TRANSMISSION OF EXCITATORY WAVES
IN PLANTS

Difficulties in accurate determination of velocity of transmission, due to unknown variations of excitability arising from injury, and variations of conductivity through fatigue—A perfect method of obtaining accurate and consistent results—Relative advantages of studying conduction in plants as compared with animals—Determinations of velocity of transmission in centripetal and centrifugal directions—Preferential conductivity in centrifugal direction—Diminution of conductivity and excitability by fatigue—Within a certain critical interval, organ ‘refractory’ to further stimulus—Increased velocity of transmission with increasing stimulus—Measurement of diminution of conductivity by cold—Fibro-vascular elements the best conducting channels—Conductivity lengthwise greater than crosswise—Electric mode of determination of velocity of transmission—Indifferent parenchymatous tissues practically not transmitters of excitation—Comparative tables showing velocity of transmission in various plant and animal tissues	238
--	-----

CHAPTER XXI

ON DETECTION OF EXCITATORY PULSE DURING TRANSIT BY
ELECTROTACTILE AND ELECTROMOTIVE METHODS

Pfeffer’s experiment on expulsion of water from excited cells—Author’s experiment on a delicate method of detecting excitatory expulsion of cell-sap—Chemical method of determining velocity of transmission of excitation—Electrotactile detector—Demonstration of passage of excitatory a	
--	--

	PAGE
contractile wave by means of electro tactile method—Determination of velocity of transmission of excitation in ordinary plants by electromotive method—Excitatory <i>versus</i> hydro-mechanical movement of water . . .	254

CHAPTER XXII

THE LATENT PERIOD AND REFRACTORY PERIOD

The determination of the latent period in *Mimosa*—Experimental arrangements for obtaining automatic record—Prolongation of latent period by cold—Spark-record for determination of latent period—Prolongation of latent period by fatigue—Sluggishness of the response of *Philanthus urinaria*, also long latent period and very protracted period of recovery—Latent period reduced under strong stimulation—Response in *Biophytum* on the 'all or none' principle—Definite value of effective stimulus—Phenomenon of refractory period in *Biophytum*—Parallelism of responses in *Biophytum* and in cardiac muscle—Additive effects—Inappropriateness of term 'refractory period'—Energy in excess of effective stimulus held latent for subsequent manifestation

264

PART IV.—MULTIPLE AND AUTONOMOUS RESPONSE

CHAPTER XXIII

ON MULTIPLE RESPONSE

Multiple electromotive responses due to a single strong stimulus—Multiple electro tactile responses—Multiple mechanical responses in *Biophytum*—Cyclic variations in multiple responses—Multiple retinal excitations—Intermittent pulse in man and plant—Semi-automatism—Continuity of multiple and automatic response—Conversion of *Biophytum* into automatically responding plant; conversion of *Desmodium* into ordinarily responding plant—Similar polar effects of current in *Biophytum* and in *Desmodium* leaflet at standstill—Moderate stimulus in *Biophytum* and in *Desmodium* at standstill produces single response; and strong stimulus, multiple response

279

CHAPTER XXIV

AN INQUIRY INTO THE CAUSES OF AUTONOMOUS MOVEMENTS

Production of pulsatory movements as after-effect of energy absorbed—Physical analogue—Localisation of seat of automatic excitation in *Desmodium*—Demonstration of multiple response to a constant stimulus : (1) Chemical—(2) Electrical—(3) Stimulus of light—Multiple response

	PAGE
to constant stimulus of light, in : (a) retina—(b) <i>Biophytum</i> —(c) <i>Desmodium</i> —(4) Thermal—Induction of automatism in <i>Biophytum</i> at favourable temperature—(5) Of internal hydrostatic pressure—Absorption of external energy and its absorption by the plant in latent form—True meaning of 'tonic' condition—Cause of rhythmicity—After-effect, and its relative persistence	295

CHAPTER XXV

INFLUENCE OF VARIOUS CHEMICAL REAGENTS ON THE
AUTONOMOUS RESPONSE OF DESMODIUM GYRANS

The recorder and experimental chamber—Absolute measurement of period and amplitude of <i>Desmodium</i> -oscillation—Responsive significance of up and down movements deduced from (a) analogy with response of <i>Mimosa</i> ; (b) test of increased internal hydrostatic pressure—'Systolic' contraction and 'diastolic' expansion of <i>Desmodium pulvinus</i> —Mode of application of chemical reagents—Action of chemical reagents modified by: tonic condition of plants ; strength of solution ; and duration of application—Effect of anæsthetics—Effect of alcohol—Effect of carbonic acid—Effects of ammonia and of carbon disulphide—Effect of copper sulphate solution, either when applied externally, direct on the pulvinus, or internally—Spark-record of <i>Desmodium</i> -pulsation	315
--	-----

CHAPTER XXVI

EFFECTS OF TEMPERATURE ON AUTONOMOUS RESPONSES

Increase of frequency and diminution of amplitude of pulsation with rising temperature—Converse effect of fall of temperature—Similar effect in cardiac pulsation—Effect of the reduction of temperature to the thermo-tonic minimum—Explanation of diminution of amplitude of pulsation with rise of temperature—Anomalous use of the word 'relaxation'—Simple <i>versus</i> additive character of individual pulsation	329
--	-----

CHAPTER XXVII

SIMILARITIES OF RHYTHMIC RESPONSE IN VEGETABLE AND
ANIMAL TISSUES

The similarities, in their fundamental characteristics, of rhythmic tissues, animal and vegetable : (1) In responses—(2) In possession of long refractory periods—(3) In incapability of tetanus—Theories regarding the causation of heart-beat—The similarities of rhythmic tissues, animal and vegetable, as seen in : (1) The effects of internal hydrostatic pressure—(2) The effects of variation of temperature—(3) The periodic groupings	a 2
--	-----

a 2

	PAGE
of response—(4) The effect of barium salt—(5) The antagonistic actions of acid and alkali—Identity of rhythmic phenomena in animal and vegetable tissues	344

PART V.—ASCENT OF SAP

CHAPTER XXVIII

SUCTIONAL RESPONSE AND ASCENT OF SAP

Inadequacy of existing theories of ascent of sap—General considerations regarding cellular activity and resultant propulsion of water—The Shoshungraph—Balanced Shoshungraph for determining variations of suction—Hydrostatic and Hydraulic Methods of Balance	359
---	-----

CHAPTER XXIX

MODIFICATION OF SUCTIONAL RESPONSE

Effect of temperature on suction by three methods of inquiry: (1) Unbalanced method of Shoshungraph: (a) Action of cold—(b) Action of moderate rise of temperature—(2) Method of Hydrostatic Balance: (a) Action of cold—Reversal of normal direction of flow—(b) Action of warm water—(3) Method of Hydraulic Balance—(a) Action of cold—(b) Effect of warm water—Explanation of suction when the root is killed by boiling water—Stimulation renews suctional activity in plant whose suction has come to a standstill—Osmotic <i>versus</i> excitatory action—Abolition of suction by poison—Suctional activity continued until whole plant is killed by poison	372
--	-----

CHAPTER XXX

THE PHENOMENON OF PROPULSION OF SAP AND ITS VARIOUS EFFECTS

The mechanics of the ascent of sap: (a) Uni-directioned flow—(b) Initiation of multiple rhythmic excitations—Connection between conduction of excitation and conduction of sap—Rapidity of ascent of sap accounted for by stimulatory action—Positive and negative pressures due to one cause—(1) Positive pressure—(2) Negative pressure—(3) Irregular variations of pressure—Direct conduction and conduction by relays—Excretion of water—Excretion of nectar—Translocation of organic food-substances—Mechanical response to suctional activity—Effect of warmth—Effect of cold—Explanation of the drooping of leaves during frost—Explanation of response and recovery—Antagonistic actions of internal energy and external stimulus	389
---	-----

PART VI.—GROWTH

CHAPTER XXXI

THE RECORD OF GROWTH-RESPONSE

	PAGE
The simple Crescograph—The Balanced Crescograph—Rhythmic growth-response—Growth-response and excitatory response—Law of direct and indirect effects of excitation—Positive turgidity-variation as indirect effect of excitation—Mechanical test—Significance of 'inner stimuli' . . .	409

CHAPTER XXXII

THE EFFECTS ON GROWTH OF INTERNAL ENERGY
AND EXTERNAL STIMULUS

Characteristics common to growth and to other forms of rhythmic response :

(1) Periodic groupings—(2) Effect of external stimulus in renewal of growth when at temporary standstill—(3) Renewal of growth-pulsation by positive turgidity-variation—(4) Effect of increased internal hydrostatic pressure—(5) Effect of ascent of sap on growth—Effect of temperature on growth—Comparison of various types of multiple response—Effect of external tension on growth—Effect of direct application of stimulus on the growing region—Similarities between motile and growth responses—Direct and indirect effects of stimulus, and laws of growth . . .	424
--	-----

CHAPTER XXXIII

ON THE RELATION BETWEEN TEMPERATURE AND GROWTH,
AND THE ACCURATE DETERMINATION OF OPTIMUM AND
MAXIMUM POINTS

General consideration of difficulties of accurate determination of effects of temperature on growth—Four accurate methods : (1) Method of discontinuous observations—Accurate regulation of temperature by electrolytic rheostat—(2) Method of continuous observations—Thermo-crescent curve—Determination of the optimum point—(3) Method of balance—(4) Method of excitatory response—Translocation of the optimum point . . .

441

CHAPTER XXXIV

ON AN ATTEMPT TO DETECT AND MEASURE LATENT STIMULUS,
AND ON THE STUDY OF PERIODIC AFTER-EFFECTS

Positive and negative after-effects—Extreme delicacy of the Method of Balance—Detection of absorbed stimulus by negative after-effect—

	PAGE
Constancy of sum of direct and indirect after-effects—Latent component almost vanishing above the optimum—Variation of receptivity—Direct and indirect response of plant in sub-tonic condition—Table showing direct and indirect effects at different temperatures—Is the change induced by stimulus always of an explosive chemical character?—Relation between stimulus and response in different tonic conditions—After-effect—Factors which determine periodic after-effects: (1) Stimulus of light—(2) Temperature—(3) Chemical stimulus—(4) Turgidity—Continuous photographic record of the pulsations of <i>Desmodium</i> —Record of periodic variation of rate of growth—Continuous photographic record of periodic variations of transpiration—Continuous photographic record of the variation of the rate of growth—Annual rings and seasonal periodicity	456

CHAPTER XXXV

AN INVESTIGATION INTO THE DIFFERENT EFFECTS OF DRUGS ON PLANTS OF DIFFERENT 'CONSTITUTIONS'

General consideration of the problem—'Constitution' and the elements which determine it—Methods of investigation—Action of carbonic acid gas—Action of ether—Effect of solution of sodium carbonate—Effect of solution of sugar—Effect of alcohol—Effect of acids—Effect of alkali—Antagonistic action of alkalis and acids—Action of strong solution of sodium chloride—Effect of poisonous solution of copper sulphate—Opposite effects of the same dose on different constitutions—Opposite effects of large and small doses	477
---	-----

PART VII.—GEOTROPISM, CHEMOTROPISM, AND GALVANOTROPISM

CHAPTER XXXVI

THE RESPONSIVE CURVATURES CAUSED BY GRAVITY. NEGATIVE GEOTROPISM

Statement of the problem of apogeotropic response—Mode in which stimulation is brought about: radial-pressure theory, and theory of statoliths—Mechanics of responsive movement—Experiment demonstrating responsive curvature as brought about by unilateral pressure of particles—Record of curvature induced by gravitation—Record of different rates of curvature when specimen is held at angles of 45° and 135° to the vertical—Determination of the true character of apogeotropic response—Responsive curvature of acellular organs—Curvature of grass haulm under gravity—Growth of grass haulm on a klinostat	493
--	-----

CHAPTER XXXVII

THE RESPONSIVE PECULIARITIES OF THE TIPS OF GROWING ORGANS

	PAGE
Difference between shoot and root in their response to stimulus of gravity—Difference in character of response between tip and growing region of root—Scope of the investigation—Electrical investigation—Responsive results of: 1. Longitudinal transmission of effect of stimulus from tip; (a) Moderate unilateral stimulation; (b) effect of stronger unilateral stimulation—2. Direct unilateral stimulation of growing region—Moderately strong stimulus—3. Transverse transmission of effect of stimulus; (a) moderate stimulation; (b) stronger stimulation—Mechanical response inferred from observed electrical response—Tabular statement	512

CHAPTER XXXVIII

INQUIRY INTO THE LAWS OF RESPONSIVE GROWTH-CURVATURES

Scope of the investigation: 1. Mechanical response to unilateral stimulation of the tips of shoot and root: (a) Moderate stimulus—(b) Stronger stimulation—2. Effect of unilateral stimulus, applied at the responding growing region: (a) Moderate stimulus—(b) Strong or long-continued stimulus—Experiments on the direct and indirect effects of stimulus on <i>Mimosa</i> : (a) Direct stimulation—(b) Indirect stimulation, longitudinal transmission—(c) Indirect stimulation, transverse transmission—The curious response of <i>Arisæma</i> —Table showing responsive effects common to pulvini, pulvinoids, and growing organs—Laws of responsive growth-curvature	524
--	-----

CHAPTER XXXIX

INQUIRY INTO POSITIVE GEOTROPISM

No specific difference as regards their responses, between shoot and root—Darwinian curvature—Localisation of geotropic sensibility at the root-tip—Experiments as to whether amputation of root-tip abolishes excitability—The tip of the root the organ of gravi-perception—The perceptive <i>versus</i> the responding organ—True perceptive region	536
--	-----

CHAPTER XL

ON CHEMO-TROPISM AND GALVANO-TROPISM

General difficulties of the investigation—How to overcome these difficulties—Three distinct methods of testing results: (1) by variation of longitudinal	
--	--

	PAGE
growth ; (2) by responsive movement of pulvinus ; and (3) by growth-curvature—Method of application of chemical reagent—Effect of alkali—Effect of acid—Effect of copper sulphate—Action of sugar solution—Chemo-tactic movements—Explanation of anomalous osmotic or plasmolytic action—Excitatory <i>versus</i> plasmolytic reaction in pulvinus of <i>Mimosa</i> : (1) Favourable tonic condition—(2) Ordinary tonic condition—Polar effects of currents inducing growth-curvatures—Localised polar effects on pulvinus—Anodic and cathodic effects on longitudinal growth—Generalised law of polar excitation in plants—Galvano-tropic response—The indirect effect of polar excitation—The effect on growth of ‘electrification’ of soil	546

PART VIII.—HELIOTROPISM

CHAPTER XLI

FUNDAMENTAL RESPONSIVE ACTION OF PLANT-TISSUES TO STIMULUS OF LIGHT

Diversity of movements induced by light—Differentiation of responsive movements—Action of light on tissues in sub-tonic condition—Effect of light on pulvinated organs—Effect of diffuse stimulation of light on non-growing radial organs—Retarding effect of light on longitudinal growth—Phenomenon of oscillation under long-continued stimulation—Similarity of responsive reaction under light and under other forms of stimulation	565
---	-----

CHAPTER XLII

POSITIVE HELIOTROPISM

Introduction—Theory of de Candolle—Inadequacy of de Candolle’s theory—Definition of terms positive and negative—Darwin’s theory of modified circumnutation—Response of terminal leaflet of <i>Desmodium</i> —Extreme sensitiveness of some plant-organs to light—Merging of multiple in continuous response—Orientation induced by light—The perceptive region in the terminal leaflet of <i>Desmodium</i> —Heliotropic response in radial organ—Magnetically controlled recorder—Heliotropic response of hypocotyl of <i>Sinapis</i> —Recovery and theory of recti-petality.	579
---	-----

CHAPTER XLIII

NEGATIVE HELIOTROPISM

Incomplete parallelism between actions of light and of gravitation—Theoretical considerations—Recording microscope—Negative helio-	
--	--

	PAGE
tropic curvature induced by stimulation of the tips of root and shoot— Intermediate phases between positive and negative heliotropic response : (a) neutralisation by transverse transmission ; (b) neutralisation by transverse transmission, with multiple response—Localised sensitiveness to light and transmission of excitatory effect—Negative heliotropism of a radial organ—Gradual transition from positive to negative, through intermediate phase of neutrality—Apparent heliotropic insensitiveness of certain tendrils—Negative heliotropism of tendril of <i>Vitis</i>	597

CHAPTER XLIV

EFFECT OF INVISIBLE RADIATION AND EMANATIONS

Effect of temperature and its variations—Demonstration of fundamental effect of thermal radiation on growth—Response to successive uniform stimuli of thermal radiation—Effect of continuous unilateral stimulation —Effect of electrical waves on growth—Response of <i>Mimosa</i> to electric radiation—Action of high frequency Tesla current	614
--	-----

CHAPTER XLV

ON PHOTONASTIC PHENOMENA AND ON DIURNAL SLEEP

Photonasty and para-heliotropism—Response of <i>Tropaeolum majus</i> —Re- sponses of plagiotropic stems : (a) <i>Mimosa</i> —(b) <i>Ipomoea</i> —(c) <i>Cucurbita</i> — Daily periodic movements of plagiotropic stems—Responsive movements of pulvinated organs—Pulvinated organs showing positive heliotropic movement : (a) Response of terminal leaflet of <i>Desmodium</i> —(b) Response of leaflet of <i>Robinia</i> —(c) Responsive movements of leaflets of <i>Erythrina indica</i> and <i>Clitoria ternatea</i> —The negative heliotropic type of response : (a) Response of pulvinus of <i>Mimosa</i> —(b) Diurnal sleep of <i>Oxalis</i> —(c) Diurnal sleep of <i>Biophytum</i> —Directive <i>versus</i> non-directive action of light—General view of responsive curvatures induced in different organs by unilateral application of light	621
---	-----

CHAPTER XLVI

ON DIA-HELIO TROPISM AND DIA-GEOTROPISM

Difficulty of distinguishing between effect of light and other reactions— Theories of Frank and De Vries—Subsidiary factors : (1) Epinasty and hyponasty ; (2) Effect of gravity ; (3) Effect of suctional activity and of turgescence ; (4) Modification of effect by characteristic limits of flexibility—Discrimination of the part played by heliotropism in the movement of the leaf—Proof of absence of any specific dia-heliotropic tendency in leaves—The lamina not the perceptive organ—Principal types of the response of leaves to stimulus of light—Positive type of response : mango leaf—Negative type of response : leaf of <i>Artocarpus</i>	640
---	-----

CHAPTER XLVII

TORSIONAL RESPONSE TO HELIOTROPIC AND GEOTROPIC STIMULUS: AUTONOMOUS TORSION AND ITS VARIATIONS

	PAGE
Torsional effect—Method of recording torsional response—Torsional response under the lateral action of light—Torsional response to other forms of lateral stimulation—Torsional response of compound strip of ebonite and stretched india-rubber—Modification of torsional response by artificial variation of the relative excitabilities of the two halves—Laws of torsional response—Demonstration of differential geotropic excitation in a dorsi-ventral organ—Torsional response to lateral geotropic stimulation—Modification of torsional geotropic response by artificial variation of differential excitability—Autonomous torsion: Effect of temperature—Effect of light—Effect of electrical current—Effect of gravity—The twining of stems	656

CHAPTER XLVIII

NYCTITROPIC MOVEMENTS

Comparison between nyctitropic and autonomous pulsations—Diurnal movement of plagiotropic stem—Supposed distinction between nyctitropic and other movements of response to stimulus of light—Diurnal response of leaf of <i>Biophytum</i> —Diurnal response of primary petiole of <i>Mimosa</i> —Periodic impulses acting on the leaf—Periodic impulses contributed by the plant as a whole—Other modes of exhibition of diurnal periodicity of hydrostatic tension—Forced vibration and its periodic after-effects—Physical analogue—Impressed periodic vibrations in organ originally radial	676
--	-----

CHAPTER XLIX

ON PULSATORY RESPONSE AND SWIMMING MOVEMENTS AS INITIATED AND MODIFIED BY LIGHT AND OTHER FORMS OF STIMULUS

Investigations on the influence of light on the lateral leaflet of <i>Desmodium gyrans</i> : (a) in sub-tonic condition; (b) in normal tonic condition—Changes induced in existing anisotropy of <i>Desmodium</i> leaflets—Reversal under intense stimulation seen in all forms of response—The swimming movements of ciliated organisms—Fundamental resemblance between the swimming responses and the ordinary heliotropic responses in radial organs—Phototactic movements: (a) Two natural types of responsive movements; (b) Responsive movement positive, negative, or intermediate, according to intensity of stimulation—Directive action of light—Thermotaxis—Galvanotaxis—Chemotaxis	689
--	-----

PART IX.—GENERAL SURVEY AND CONCLUSION

CHAPTER L

REVIEW OF RESPONSE, SIMPLE AND MULTIPLE

	PAGE
Responsive contraction—Kunchangraphic records—Direct and indirect effects of stimulation—Various forms of responsive expression; (<i>a</i>) Lateral motile response by differential contraction; (<i>b</i>) Suctional response; (<i>c</i>) Growth-response; (<i>d</i>) Torsional response; (<i>e</i>) Death response; (<i>f</i>) Thermographs of regional death; (<i>g</i>) Electrical response—Different types of response: (<i>a</i>) Uniform response; (<i>b</i>) Fatigue; (<i>c</i>) Staircase response—Excitability—Conductivity—Polar effects of currents—Multiple response—Continuity of multiple and autonomous responses—The ascent of sap	703

CHAPTER LI

RESPONSIVE GROWTH-CURVATURES IN PLANTS

Longitudinal growth and its variations—Effect of temperature on growth—Responsive growth-curvature under unilateral stimulation:—1. Direct unilateral stimulus on the responding organ: (<i>a</i>) Positive response under moderate stimulation; (<i>b</i>) Intermediate or neutral response; (<i>c</i>) Negative response; (<i>d</i>) Dorsi-ventral positive response; (<i>e</i>) Dorsi-ventral response which may become negative—2. Indirect effect of unilateral stimulation: (<i>a</i>) Negative response; (<i>b</i>) Positive response—Responsive action under stimulus of gravity—Heliotropic action in radial organs—Heliotropic action in plagiotropic and dorsi-ventral organs—Phototactic movements—Nyctitropic movements	725
--	-----

CHAPTER LII

ON PHYSIOLOGICAL RESPONSE, AND ITS CONTINUITY IN PLANT AND ANIMAL

Vitalism—Fundamental unity of physiological response in plant and animal—Theory of Darwin—Variation as induced by external forces	740
CLASSIFIED LIST OF EXPERIMENTS	755
INDEX	765

ERRATUM

Page 409, line 1 of analytical contents, *for* Growth-Recorder *read* Crescograph.

ILLUSTRATIONS

FIG.	PAGE
1. Record of Healthy Adult and Senile Human Pulse (Broadbent) . . .	3
2. Effect of Muscarin in arresting Pulsation of Frog's Ventricle (Cushing)	4
3. Record of Human Pulse (Broadbent)	4
4. Demonstration Optical Pulse-Recorder	7
5. Death of Plant, and Arrest of Pulsation, by Poison	8
6. Death, and Arrest of Pulsation, in Leaflet of <i>Desmodium</i> by Strong Electric Shock	8
7. Response of India-rubber	12
8. Mechanical Lever Recorder	12
9. Series of Contractile Responses in Muscle	13
10. Photographic Record of Longitudinal Contractile Response in ordinary Stamens (<i>Brownea ariza</i>)	13
11. Differential Lateral Response of Compound Strip	13
12. Plant Chamber and Recorder	16
13. The Electro-thermic Stimulator	17
14. Diagram of Connections for Stimulation by Condenser Discharge .	18
15. Photographic Record of Response and Recovery of <i>Mimosa</i> , taken on a slowly moving drum	21
16. Photographic Record of Response in different specimen, taken on a faster-moving drum	21
17. Response of <i>Biophytum</i> to Thermal Stimulation	24
18. Response of <i>Biophytum</i> to Electric Stimulation	24
19. Effect of Load	25
20. The Spiral Spring-Recorder	26
21. Isometric Response of <i>Mimosa</i>	26
22. Hydraulic Model for Explanation of Electric Response	31
23. Electrical Response in Plant by Method of Block	32
24. Electric Response Recorder	33
25. Method of Transmitted Stimulation	33
26. Simultaneous Mechanical and Electrical Responses in <i>Biophytum</i> . .	34
27. The Abnormal Positive preceding the Normal Negative in Mechanical and Electrical Responses in <i>Biophytum</i>	37
28. Response of Selenium to the Stimulus of Light	39

FIG.		PAGE
29.	Response of Metal abolished by the action of 'Poison' (Oxalic Acid) .	40
30.	Responses of quickly reacting <i>Biophytum</i> , and sluggish <i>Philanthus urinaria</i> , under moderate and under stronger Stimulation . . .	44
31.	Artificial Hydraulic Response of <i>Mimosa</i>	46
32.	Response of Ordinary Leaf (<i>Artocarpus</i>)	56
33.	Response of Leaves of Ordinary Plants to Electric Stimulation . . .	64
34.	Alternate opposite-directioned Responses obtained by the successive Unilateral Stimulations of opposite sides of Pistil of <i>Musa</i> . . .	68
35.	The Kunchangraph	73
36.	Diagrammatic Representation of Apparatus for Periodic Stimulation of Plant	75
37.	Response of Stem of <i>Cuscuta</i> to Electric Stimulation	77
38.	Photographic Record of Responses of Style of <i>Datura alba</i> to Thermal Stimulation	78
39.	Responses of Plagiotropic Stem of <i>Cucurbita</i>	86
40.	Responses of Plagiotropic Stem of <i>Convolvulus</i>	86
41.	Response of Bifurcated <i>Allium</i> Tube by sudden Collapse	87
42.	Responses of Hooked Tendril of <i>Passiflora</i>	90
43.	Response by Coiling of spirally-cut <i>Allium</i> Peduncle	91
44.	Ineffective Stimulus made Effective by Repetition	95
45.	Additive Effect in Electrical Response	95
46.	Mechanical Responses to Stimuli increasing in Arithmetical Progression	96
47.	Curve showing Relation between Stimulus and Response	96
48.	Increased Electrical Response with Increasing Vibrational Stimuli (Cauliflower-stalk)	97
49.	Genesis of Tetanus in Muscle	98
50.	Photographic Record of Genesis of Tetanus in Mechanical Response of Plants (Style of <i>Datura alba</i>)	99
51.	Uniform Electrical Responses (Radish)	104
52.	Staircase Effect in Longitudinal Mechanical Response of Plant (Style of <i>Eucharis</i>)	104
53.	Fatigue in Longitudinal Mechanical Response of Plant (Style of <i>Datura</i>).	105
54.	Fatigue shown in Electrical Response, when sufficient Time is not allowed for Full Recovery	105
55.	Alternate Fatigue in Electrical Responses of Petiole of Cauliflower ; in Multiple Electric Responses of Peduncle of <i>Biophytum</i> ; in Multiple Mechanical Responses of Leaflet of <i>Biophytum</i> ; and in Autonomous Responses of <i>Desmodium</i>	106
56.	Rapid Fatigue under Continuous Stimulation in Muscle, and in Leafstalk of Celery	107
57.	Fatigue under long-continued Stimulation in the Contractile Response of Plants	108
58.	Photographic Record of Periodic Fatigue under Continuous Stimulation in Contractile Response (Filament of <i>Urclis</i> Lily)	108
59.	Photographic Records of Normal Response of <i>Mimosa</i> to Single Stimulus (upper figure), and to Continuous Stimulation (lower figure)	109

FIG.		PAGE
60.	Ineffectiveness of Stimuli, owing to Increasing Fatigue, in <i>Mimosa</i>	113
61.	Fatigue-Reversal in Arsenic, under Continuous Stimulation of Hertzian Radiation	119
62.	Automatic Record of Fatigue in the Contractile Response of India-rubber under Rapidly Succeeding Thermal Shocks	120
63.	Preliminary Staircase Increase, followed by Fatigue, in the Response of <i>Galena</i> to Hertzian Radiation	121
64.	Preliminary Staircase Increase, followed by Fatigue, in the Response of Style of <i>Eucharis</i>	121
65.	Preliminary Staircase, followed by Fatigue, in the Responses of Muscle (Brodie)	122
66.	Staircase Increase in Electrical Response of Petiole of <i>Bryophyllum</i> , rendered sluggish by cooling	122
67.	Mechanical Response in Tendril of <i>Passiflora</i> in which Growth was originally at Standstill	127
68.	Effect of Carbonic Acid Gas on Longitudinal Contractile Response	131
69.	Effect of Hydrogen Gas	132
70.	Photographic Record showing Effect of Carbon Disulphide in Abolishing Response	132
71.	Effect of Vapour of Alcohol	134
72.	Effect of Ether	135
73.	Effect of HCl Vapour	136
74.	Action of Chlorine	137
75.	Diminution of Response in <i>Eucharis</i> Lily by Lowering of Temperature	140
76.	After-effect of Cold on Ivy, Holly, and Eucharis	141
77.	Effect of Cold on Longitudinal Response	143
78.	Effect of Rise of Temperature on Electrical Response	144
79.	Effect of Rise of Temperature on Longitudinal Contractile Response of Plant	144
80.	Effect of Rising and Falling Temperature on the Electrical Response of Scotch Kale (stimulus constant)	145
81.	Effect of Cyclic Rise and Fall of Temperature on Longitudinal Mechanical Response in Plant	146
82.	Determination of Death-point in <i>Allium</i> Tube by Observation of Volumetric Contraction, causing sudden Expulsion of Water	157
83.	The Thermometric Spiral and Optic Lever of the Morograph	165
84.	The Morograph	167
85.	Thermo-mechanical Curve obtained Photographically (Coronal Filament of <i>Passiflora</i>)	168
86.	Thermo-mechanical Curve of Two Different Specimens of Style of <i>Datura alba</i> , obtained from Flowers of the same Plant	169
87.	Thermo-mechanical Records of Young Specimen of <i>Spirogyra</i> ; Older Specimen of same; and Style of <i>Datura alba</i>	170
88.	Thermo-mechanical Record of Leaf of <i>Mimosa</i>	172
89.	Diagrammatic Representation of Mono-polar Excitation	193
90.	Bi-polar Excitation of <i>Mimosa</i>	194
91.	Bi-polar Excitation of <i>Biophytum</i>	194
92.	Make-kathode and Break-anode Effects in <i>Biophytum</i>	195

FIG.		PAGE
93.	Record of Responses of Leaflet of <i>Biophytum</i> , showing Responses occurring at Kathode at Make and not at Break ; and at Anode at Break and not at Make	196
94.	Effects of Ascending and Descending Currents, on Highly Excitable Specimen of <i>Mimosa</i>	197
95.	Molecular Model Exhibiting Excitability at the Receptive Area ; Conductivity of Intervening Region ; and Mechanical Response of Terminal Responder	218
96.	Effect of Ether in the Abolition of Motile Excitability	220
97.	Experimental Demonstration of Effects of Cold and Anæsthetics in Abolishing Conductivity	222
98.	Diagrammatic Representation of Experiment on <i>Biophytum</i>	224
99.	Effect of Anode as Block	233
100.	Experiment showing the Transmission of Excitatory Wave through Kathodic Area, and its Stoppage by the Anode	233
101.	Demonstration of Simultaneous Opposite Effects of Anode and Kathode on Transmission of Excitation	234
102.	Diagrammatic Representation of Electrical Connections in <i>Mimosa</i> to Exhibit Variation of Motile Excitability, induced by Anode and Kathode	235
103.	'Developing' Action of Kathode	236
104.	Diagrammatic Representation of Electrical Connections for Determination of Velocities of Centrifugal and Centripetal Transmissions	242
105.	Curve showing Decline in Heights of Responses, with Diminishing Periods of Rest	246
106.	Electrotactile Method for Detection of Excitatory Wave during Transit	259
107.	Electrotactile Response in Stem of <i>Mimosa</i>	260
108.	Experimental Arrangements for Simultaneous Recording of Mechanical and Electrical Responses	261
109.	Apparatus for Automatic Record	266
110.	Photographic Record of Response of <i>Mimosa</i> , Exhibiting the Latent Period in its Variation	268
111.	Electric Spark Record, showing Increase of Latent Period by Fatigue, in Successive Responses of a Leaf of <i>Mimosa</i>	269
112.	Response of <i>Biophytum</i> ; Electrical Stimulus having been Applied at the Pulvinus of the Motile Leaflet	270
113.	Additive Effects seen in Responses of <i>Biophytum</i> to Stimuli which Fall outside the Refractory Period	274
114.	Multiple Electrical Responses due to Single Strong Stimulus	280
115.	Multiple Electrotactile Response in Stem of <i>Mimosa</i> , due to Single Strong Thermal Stimulus	280
116.	Multiple Mechanical Response of <i>Biophytum</i> , due to a Single Thermal Stimulus	283
117.	Multiple Response in <i>Biophytum</i>	285
118.	Multiple Response in <i>Biophytum</i>	285
119.	Multiple Response in <i>Biophytum</i> , showing Cyclic Groupings of Amplitude and Period	286

FIG.		PAGE
120.	Multiple Response in <i>Biophytum</i> , showing Cyclic Groupings	286
121.	Intermittent Human Pulse (Broadbent)	288
122.	Intermittence in Pulsation of <i>Biophytum</i>	289
123.	Multiple Response of <i>Biophytum</i> under the Continuous Action of Light	303
124.	Induction of Autonomous Response in <i>Biophytum</i> , at Moderately High Temperature of 35° C.	305
125.	Experimental Apparatus for Making Records of Pulsation of <i>Desmodium</i>	316
126.	Photographic Record of Pulsation of <i>Desmodium</i>	317
127.	Photographic Record of Uniform Pulsations in <i>Desmodium</i>	318
128.	Displacement of Mean Position of Vibration of <i>Desmodium</i> Leaflet by Increased Internal Hydrostatic Pressure	320
129.	Method of Application of Chemical Agent to Cut End of Petiole	321
130.	Photographic Record of Effect of Ether Vapour, Large Dose	324
131.	Photographic Record of Effect of Alcohol	325
132.	Photographic Record of Effect of Carbonic Acid Gas	325
133.	Photographic Record of Effect of Copper Sulphate Solution Applied on the Pulvinus	326
134.	Spark-record of Single Pulsation in Leaflet of <i>Desmodium</i>	327
135.	Photographic Records of Autonomous Pulsations in <i>Desmodium</i> , showing Increase of Amplitude and Decrease of Frequency, with Lowering of Temperature	332
136.	Effect of Lowering of Temperature in Producing Increase of Amplitude and Decrease of Frequency in Pulsation of Frog's Heart	333
137.	Photographic Record of Pulsations of <i>Desmodium</i> during Continuous Rise of Temperature	333
138.	Record of Pulsations of <i>Desmodium</i> at Different Temperatures	334
139.	Record of Pulsations of Frog's Heart at Different Temperatures (Pembrey and Phillips)	334
140.	Effect of Cooling to Thermo-tonic Minimum on Pulsation of <i>Desmodium</i>	335
141.	Effect of Rapid Cooling by Ice-cold Water	336
142.	Photographic Record of Pulsation of <i>Desmodium</i> , showing Sub-pulses during slower Up Movement, as Nodules	340
143.	Photographic Record of Cyclic Groupings in Autonomous Pulsations of <i>Desmodium</i> , showing Sub-pulses	341
144.	Photographic Record of Autonomous Pulsation of <i>Desmodium</i> , showing Hourly Period	341
145.	Record showing that Rhythmic Tissue of <i>Desmodium</i> is Incapable of being Tetanised	346
146.	Curve showing Relation between Temperature and Period of Pulsation in <i>Desmodium</i>	349
147.	Curve showing Relation between Temperature and Period of Pulsation in the Heart of a Frog	349
148.	Simple Alternation of Pulsation in <i>Desmodium</i>	350
149.	Periodic Groupings of Pulsation in <i>Desmodium</i>	350
150.	Simple Alternation of Pulsation in Frog's Heart (Pembrey and Phillips)	350

b

FIG.		PAGE
151.	Effect of Barium Chloride Solution on <i>Desmodium</i>	351
152.	Arrest of Beat of Ventricle of Frog at Diastole by Application of Acid	351
153.	Systolic Arrest of Heart-beat by Dilute NaHO Solution (Gaskell)	352
154.	Arrest of <i>Desmodium</i> Pulsation at 'Diastole' by Application of Acid	352
155.	Arrest of Pulsation of <i>Desmodium</i> at 'Systole' by Application of Dilute Alkali	353
156.	Diagrammatic Representation of the Shoshungraph	365
157.	Photograph of Shoshungraph	370
158.	Effect of Cold on Suction	374
159.	Curve showing Normal Suction at 23° C., Increased Suction at 35° C., and the After-effect persisting on Return to Normal Temperature	375
160.	Method of Hydrostatic Balance	375
161.	Record obtained by Method of Hydrostatic Balance of Successive Applications of Cold and Warm Water	378
162.	Record, obtained by Method of Hydraulic Balance, of Successive Effects of Cold and Warm Water	380
163.	Effect of Strong KNO ₃ Solution	384
164.	Effect of Strong NaCl Solution	384
165.	Effect of Copper Sulphate Solution	386
166.	Record showing Recovery to be Hastened by the Increase of Internal Activity which is caused by Application of Warm Water to the Roots	401
167.	Diagrammatic Representation of Balanced Crescograph	414
168.	Complete Apparatus for Crescographic Record under Ordinary and Balanced Conditions	416
169.	Multiple Growth-responses (Peduncle of <i>Crocus</i>)	417
170.	Responses of Leaf of <i>Artocarpus</i> to Thermal Stimulation	420
171.	Renewal of Growth-pulsation by Thermal Stimulus in <i>Tamarindus indica</i> originally at Standstill	425
172.	Initiation of Erectile Response in Leaf by Supply of Water to partially Drought-rigored <i>Mimosa</i>	426
173.	Initiation of Growth-pulsation by Small Supply of Water to Drought-rigored Seedling of <i>Cucurbita</i>	426
174.	Curve showing Relation between Internal Hydrostatic Pressure and Rate of Growth (<i>Crinum</i> Lily)	429
175.	Photographic Record showing the Slow Pulsations of Large Amplitude of <i>Desmodium</i> Leaflet at 30° C. to become very much Quickened and Reduced in Amplitude at 42° C.	431
176.	Growth-pulsation seen in Seedling of <i>Balsam</i>	432
177.	Photographic Record of Responses of Mature Style of <i>Datura alba</i> to External Thermal Stimulus	434
178.	Photographic Record of Responses of Style of <i>Datura alba</i> in which Growth had come to a Temporary Stop	435
179.	Photographic Record of Response of Growing Style of <i>Datura alba</i> to External Stimulus	436

ILLUSTRATIONS

XXXV

FIG.		PAGE
180.	Balanced Record of Response in Growing Peduncle of <i>Eucharis</i> Lily to Electrical Stimulation	436
181.	Semicircular Electrolytic Rheostat interposed in Heating Circuit	443
182.	Record of Growth in <i>Crinum</i> at Temperature of 34° C. and 35° C.	445
183.	Thermo-crescent Curve of Growth in <i>Crinum</i> Lily under Continuously Increasing Temperature	447
184.	Curve showing Relation between Temperature and Rate of Growth, as deduced from the Thermo-crescent Curve	449
185.	Series of Responses of Growing Organ of <i>Crinum</i> Lily, taken under Balanced Conditions at Three Different Temperatures	460
186.	Curve showing the Relation between Stimulus and Response in the same Organ, under the two different Tonic Conditions of 30° C. (upper curve) and 37° C. (lower curve).	467
187.	Continuous Photographic Record of Autonomous Pulsation of <i>Desmodium gyrans</i> from 6 P.M. to 6 A.M.	470
188.	Hydrometric Apparatus for Recording Continuous Variation of Rate of Growth	471
189.	Photographic Record showing Variation of Rate of Transpiration in <i>Cucurbita</i> , from 3 P.M. to 12 P.M.	472
190.	Continuous Photographic Record of Variation of Rate of Growth in Four Days' Old Seedling of <i>Oryza sativa</i> , from 3 P.M. till 9 A.M., that is during Eighteen Hours	473
191.	Continuous Photographic Record of Variation of Rate of Growth in Seedling of <i>Tamarindus indica</i> , a Fortnight Old, from 3 P.M. to 3 A.M.	474
192.	Effect of Carbonic Acid Gas on Growth	480
193.	Balanced Records of Effect of Ether on Growth	481
194.	Excitatory Effect of Dilute Solution of Sodium Carbonate on Growth	481
195.	Acceleration of Growth by Application of Solution of Sugar	482
196.	Spasmodic Alternations of Growth under Alcohol	483
197.	Unbalanced Record showing Action of Acid in Causing Relaxation and Ultimate Arrest of Growth	483
198.	Unbalanced Record showing the Action of Alkali, and the Antagonistic Action of Subsequent Application of Acid	484
199.	Effect of Strong Solution of NaCl on Rate of Growth, as Modified by Different Constitutions of Specimens	484
200.	The Effect of Different Constitutions in Determining the Resistance Offered to Poisons. The Action of 5 per Cent. Solution of Copper Sulphate	487
201.	The Effect of Favourable Induced Constitution in Enabling Plant to Shake off Result of Toxic Dose of Copper Sulphate	487
202.	Opposite Effects of Large and Small Doses of Poison	488
203.	Diagrammatic Representation showing Differential Effect of Weight on Lateral Walls of Cells	494
204.	Diagrammatic Representation of a Multicellular Organ	495

FIG.	PAGE
205. Diagrammatic Representation of Experiment showing Curvature Induced by Unilateral Pressure Exerted by Particles	497
206. Record of Responsive Curvature induced in <i>Crinum</i> under Experimental Conditions shown in fig. 205	498
207. Record of Apogeotropic Response in Scape of <i>Uriclis</i> Lily	500
208. Response Records showing Differences in Rate of Curvature according as Specimen is held at Angles of 45° and 135°	501
209. Diagrammatic Representation of Different Positions of a Single Cell, according as the Specimen is held at an Angle of 45° or 135°, showing Consequent Redistribution of Statoliths (after F. Darwin)	502
210. Effect on Apogeotropic Movement of Application of Ice-cold Water to Upper and Lower Surfaces alternately of a Horizontally laid <i>Crinum</i> Lily	504
211. Effect on Apogeotropic Movement of Temporary Applications of Cold alternately to Upper and Lower Surfaces of Horizontally laid Scape of <i>Uriclis</i> Lily	505
212. Experimental Connections for obtaining Electrical Response due to Direct and Indirect Effects of Stimulation	515
213. Record of Positive Electrical Variation, indicating Positive Turgidity-Variation (represented by Down Curve), induced in Growing Region by Moderate Stimulation on same side of Tip	517
214. Record showing Galvanometric Positivity subsequently Neutralised under Transmission of True Excitatory Effect, due to Continuance of Moderate Stimulation of the Tip	517
215. Record showing Neutralisation and Reversal of Electrical Response at Responding Region, under Strong Stimulation of Tip	518
216. Record showing Negative Electrical Response represented by Up Curve, indicating Negative Turgidity-Variation due to Direct Stimulation	518
217. Record showing Positive Electrical Variation indicating Positive Turgidity-Variation of Distal Point, under Moderate Stimulation of Proximal	519
218. The Relative Electrical and Turgidity Variations of two Diametrically Opposite Points when Strong and Long-continued Stimulus is applied	521
219. Mechanical Responses of Shoot and of Root to Unilateral Stimulus applied at the Tip	526
220. Mechanical Response of Root of Bindweed to very strong Unilateral Stimulation applied at the Tip	527
221. Mechanical Responses of Peduncle of <i>Crocus</i> and Root of Bindweed to Unilateral Thermal Stimulation at the Growing Region	527
222. Diagram showing the various Responsive Effects induced at the Growing Region	529
223. Experimental Arrangement for obtaining Records on Smoked Drum of Responses given to Direct and Indirect Stimulation by Leaf of <i>Mimosa</i>	530
224. Mechanical Responses of Leaf of <i>Mimosa</i>	531

ILLUSTRATIONS

xxxvii

FIG.		PAGE
225.	Erectile Response of Leaf of <i>Mimosa</i> due to Transmission of Indirect Effect to Distal Side, when Proximal is Stimulated	532
226.	Curious Response of <i>Arisama</i>	533
227.	Curves showing Effect of Amputation on Rate of Growth and Response in Root of Bindweed	541
228.	Response of Leaf of <i>Mimosa</i> in Favourable Tonic Condition to Chemical Stimulus of 3 per Cent. Salt Solution	551
229.	Response of Leaf of <i>Mimosa</i> in Ordinary Tonic Condition to the Chemical Stimulus of 10 per Cent. Solution of Salt	552
230.	Polar Effects of Currents due to Localised Application on Upper Half of Pulvinus of <i>Erythrina indica</i>	555
231.	Effects of Anode and Kathode on Variation of Rate of Growth in Root of Bindweed exhibited by Balanced Growth-record	557
232.	Responsive Curvature in Scape of <i>Crinum</i> Lily by Unilateral Application of Anode and Kathode	558
233.	Effect in Acceleration of Rate of Growth of Seedling of <i>Oryza sativa</i> of Current through the Soil	560
234.	Longitudinal Contraction and Retardation of Growth under Light in Hypocotyl of <i>Sinapis nigra</i>	572
235.	Balanced Record of Variation of Growth in Flower-bud of <i>Crinum</i> Lily under Diffuse Stimulation of Light	574
236.	Oscillatory Response of Arsenic acted on Continuously by Hertzian Radiation	575
237.	Multiple Response to Light of Terminal Leaflet of <i>Desmodium</i>	584
238.	Response of Terminal Leaflet of <i>Desmodium</i> to Strong Light from Above	586
239.	Response of Terminal Leaflet of <i>Desmodium</i> to Sunlight acting from Below	587
240.	Diagrammatic Representation of the Magnetically Controlled Recorder	589
241.	Heliotropic Chamber and Magnetically Controlled Recorder	591
242.	Heliotropic Response of <i>Sinapis</i>	593
243.	Heliotropic Response of <i>Sinapis</i> to Sunlight	593
244.	Microscope Recorder	599
245.	Record of Response of Root of <i>Sinapis nigra</i>	601
246.	Positive Heliotropic Movement of Terminal Leaflet of <i>Desmodium</i> Converted by Strong and too Long-continued Stimulus of Light into Oscillatory Movement	604
247.	Response of Hypocotyl of <i>Sinapis nigra</i>	609
248.	Responses to Successive Uniform Stimuli of Thermal Radiation in Pistil of <i>Musa</i>	616
249.	Response of Hypocotyl of <i>Tamarindus indica</i> to Continuous Stimulation of Thermal Radiation	617
250.	Effect of Electric Waves on Growth	618
251.	Response to Diurnal Light and Darkness of Plagiotropic Stem of <i>Ipomoea</i> held vertical	625
252.	Response to Daily Periodic Light and Darkness of Plagiotropic Stem of <i>Cucurbita maxima</i>	626

FIG.		PAGE
253.	Positive Heliotropic Response of Leaflet of <i>Robinia</i> to Sunlight Acting from Above	629
254.	Positive Heliotropic Response of Leaflets of <i>Erythrina indica</i>	629
255.	Responses of <i>Mimosa</i> to Sunlight of not too long Duration	631
256.	Response of Pulvinus of <i>Mimosa</i> to Action of Continuous Light from Above	632
257.	Responses of <i>Oxalis</i> to Sunlight	633
258.	Negative Multiple Response in <i>Biophytum</i> when Acted on from Above by Strong Sunlight	634
259.	Different Limits of Flexibility	647
260.	Movement of Terminal Leaflet of <i>Desmodium</i> placing itself Parallel to Incident Horizontal Light	649
261.	Curve showing Time-relations of the Responsive Angular Movement of Terminal Leaflet of <i>Desmodium</i> under Light, as represented in the last figure	649
262.	Record showing that Lamina is not the Perceptive Organ	651
263.	Positive Heliotropic Movement of Leaf of <i>Mangifera indica</i> under Sunlight acting from Above	653
264.	Negative Heliotropic Response of Leaves of <i>Artocarpus</i> under Sunlight acting from Above	654
265.	Torsional Response of Terminal Leaflet of <i>Desmodium</i> under the Action of Lateral Sunlight	657
266.	Torsion-recorder	658
267.	Torsional Response of Leaf of <i>Mimosa</i> when Laterally Stimulated by Sunlight	659
268.	Torsional Response of Leaf of <i>Mimosa</i> to Lateral Chemical Stimulus	660
269.	Torsional Response of Complex Strip of Ebonite and India-rubber under Lateral Action of Strong Radiation	660
270.	Records showing Modification of Torsional Response under Induced Variations of Differential Excitabilities in Pulvinus of <i>Mimosa</i>	662
271.	Records showing Torsional Response to Geotropic Stimulus and Induced Modifications in Terminal Leaflet of <i>Erythrina indica</i>	666
272.	Retardation and Reversal of Normal Torsional Movement by the unilateral Action of Light in <i>Porana paniculata</i>	670
273.	Photographic Record of Diurnal Movement of Petiole of <i>Biophytum</i> from 5 P.M. till 9 A.M.	680
274.	Continuous Records of the Diurnal Movement during Thirty-six Hours in Two Specimens of <i>Mimosa</i>	681
275.	Initiation of Multiple Response in Lateral Leaflet of <i>Desmodium</i> originally at Standstill	690
276.	Photographic Record of Autonomous Pulsations in Lateral Leaflet of <i>Desmodium gyrans</i> under Action of Sunlight, showing Periodic Reversals	692
277.	Model of an Artificial Plant	709
278.	Diagrammatic Representation of a Windmill with Attached Dynamo and Accumulator	742

PART I
SIMPLE RESPONSE

CHAPTER I

THE PLANT AS A MACHINE

Responsive movements in plants--Work done by plant—Plant as a machine
— Indicator-diagrams — Physiological response-curves—Pulse-records—Cardia-
grams—Modification of pulse by poison and other agencies—Automatic
response in plants—Optical Lever Recorder—Effect of external agencies on
automatic pulse-beat in plants.

FROM the moment when the germinating seedling bursts its seed-coat, a complex series of movements is initiated. The radicle turns downwards, the plumule up. Underground, the root gropes its way towards moist places, and contrives to avoid hard stones and obstacles. Above ground, the stem is seen to bend, as if in search of light. Tendrils twine about a support. These, amongst many visible movements, are striking enough, but within the unruffled exterior of the plant-body there are others, energetic and incessant, which escape our scrutiny.

Now all these activities are but so many expressions of the response of the plant to the various stimuli by which the living organism is constantly being excited. The plant-organ sometimes responds locally to the direct impact of stimulus, and at other times the effect is conveyed away by conducting elements analogous to nerves, and the responsive changes are manifested at a distance. Thus the most varied and important functions of plant-life are brought about by the power of the tissue to respond to stimulus, that is to say, by the irritability of the plant-cells.

In such fashion, work is performed continuously by the organism, as if by a machine, and the magnitude of the work performed is often very considerable, as is seen, for instance, when sprouting seedlings break through a pavement.

B

The few instances enumerated by no means exhaust the activities that go on in the living machine of the plant ; they only suffice to give us a glimpse into the complexity of its functions. We can arrive at a comprehensive idea of such multifarious and obscure phenomena only by coming to understand the machine itself, and trying to disentangle the processes by which the various stimuli supplied by the environment bring about the appropriate responsive movements in the organism. This is difficult to do, inasmuch as the intricate internal machinery is hidden from our view.

Indicator-diagrams.—Though the interior be thus concealed, however, it is still not impossible, by careful observation of external actions, to gain some conception of the hidden mechanism. Let us take, for example, the analogous case of a steam-engine. That we may be able to infer at any moment the efficiency of various hidden parts of the machine, we attach, to the moving piston, a recording apparatus, and from the diagram thus obtained we are able to judge of the working efficiency of the engine. The upstroke is followed by a downstroke, and a recording pen traces for us, on moving paper, the responsive movements. But an irregularity may suddenly take place in the curve. This is due to some internal obstruction. On removal of the cause, the amplitude of the record is restored, and the pulsating strokes resume their normal frequency.

In dealing with living machines also, we may use similar contrivances, in order to gain some indication of their efficiency ; and by means of indicator-diagrams, or 'response-curves,' thus obtained, we are able to gather much information as to the physiological perfection or imperfection of the living machine.

Pulse-records as indicators of physiological efficiency. We shall first take as an example that responsive pulsation with which we are most familiar, our own heart-beat. As in the steam-engine the energy of heat brings about the responsive movement of the piston, so in the heart, some internal stimulus brings about responsive pulsations. A

sudden contractile movement is followed by relaxation. By a series of these, the blood is forced in a pulsating manner through the arteries, and we perceive the pulsatory movement at the wrist. Physicians by feeling such pulse-throbbings are able to pronounce on the condition of a patient. Or the movements may be recorded by means of a lever-arrangement, in which the short arm of the lever rests on the throbbing pulse. Its longer arm, provided with a tracing point, records these pulsatory movements on a travelling band of paper which is moved by clock-work at a uniform rate. It is on this principle that the instruments known as sphygmographs are constructed, and the response-records, or sphygmograms, reveal the physiological condition of the individual at the time (figs. 1 and 3).

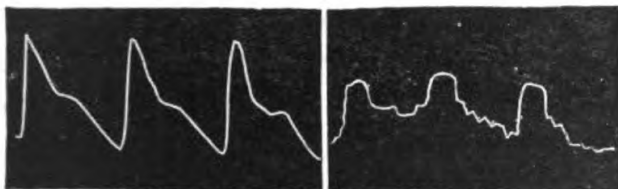

FIG. 1. Record of (a) Healthy Adult and (b) Senile Human Pulse (Broadbent)

The heart-record, however, has been still more directly obtained, in the case of the lower animals, by attaching one end of the lever to the apex of the heart itself. Each contraction and subsequent recovery is now recorded, in the manner which has been indicated. If we know the rate at which the recording surface is travelling, or if we make time-marks at regular intervals, we are able to determine the frequency of pulsation. The record also gives us the amplitude of each pulse.

If now these records are to furnish reliable indications of the internal condition of the living machine, then, any circumstance which affects this internal condition must reveal itself in the external record. And this is found to be the case. For example, the effects of age are seen in the accompanying record (fig. 1); and that of poison by

B 2

the gradual waning of pulsation, culminating in arrest at the moment of death (fig. 2). Similarly, changes of heat

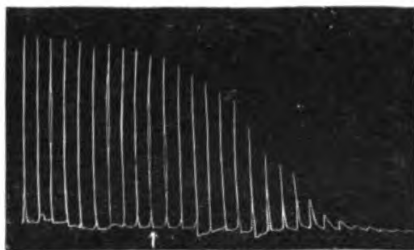

FIG. 2. Effect of Muscarin in arresting Pulsation of Frog's Ventricle (Cushing).

The arrow indicates the moment of application of reagent in this and following.

and cold, and the influence of various drugs (fig. 3), are all discernible from the modifications which they induce in the pulse-record.

For the purpose of studying the actions by which the plant responds to the various stimuli of its environment, I have been able to devise apparatus, by means of which records of its responsive pulsations may be

made. In the matter of automatic pulsations, we have in plants many instances which have not hitherto been recognised; but in one case which is well known, that of *Desmodium gyrans*—*Hedysarum gyrans*, the telegraph-plant—we observe pulsatory movements of its lateral leaflets, which, as I shall



FIG. 3. Record of Human Pulse

(a) before and (b) after Inhalation of Nitrite of Amyl. (Broadbent.)

elsewhere show, exhibit a resemblance to those of the animal heart, a resemblance which is not merely superficial, but is the result of causes fundamentally the same.

This telegraph-plant grows wild on the Gangetic plain, where its Indian name is *Bon Charal* or 'outcast of the forests,' and where the peasant belief is that it dances to the clapping of the hand. It is a papilionaceous plant with trifoliate leaves, of which the terminal leaflet is large, and the two lateral very small. Each of the latter is inserted on the petiole by means of a motile organ known as a pulvinus.

These lateral leaflets, when in normal condition, go on continuously, and apparently spontaneously, executing approximately up and down movements, each of which takes from two to four minutes to complete.

The great difficulty in recording the pulsatory movements of *Desmodium* arises from the extreme slenderness of these lateral leaflets. This is such that in attaching to them a recording lever, however light, its weight, and the friction of the writing-point, are sufficient to bring their movements to a stop. I have, however, succeeded in overcoming this difficulty by devising a recording Optical Lever.

This lever consists of a very light aluminium wire, or, which is still better, the stripped quill of a peacock's tail feather, this being extremely light, and sufficiently rigid for the purpose. The two arms of the lever are unequal. The fulcrum rod rests on frictionless supports of glass or agate. The same rod carries a light mirror. A thread of cocoon silk is stuck to the motile leaflet by a minute drop of shellac varnish. The far end of the thread is looped, and fixed at any suitable notch on the arm B of the lever. The other arm of the lever has a light sliding counterpoise. It will thus be seen that by gradually shifting the silk loop nearer the fulcrum, the magnification may be increased. When the automatically moving leaflet executes a downward movement, the arm B is pulled down, and there is a rotation of the fulcrum rod with its attached mirror. A spot of light reflected from the mirror is thus suddenly moved downwards from its original position. It will be observed that by moving the recording surface further away, the magnification may be still more enhanced. A wide latitude of magnification may thus be obtained, by changes in the effective length of arm of the lever, and by variation of the distance of the recording surface. Thus, for example, for purposes of demonstration, with a screen at a distance of five metres, it is easy to exhibit a pulsatory movement magnified to as much as one metre in amplitude. But in the case of the illustrations in the present book, it has not been found necessary to have any magnifica-

tion whatever, since the movement of the leaflet is itself considerable.

A very light counterpoise is used, as will be seen later, to exert a slight pull on the leaflet in an upward direction when necessary, the sliding arrangement enabling us to vary the amount of this tension. It will thus be seen that the leaflet is practically free from constraint, and any movement, however slight, is easily detected. When the leaflet falls, the spot of light moves, say downwards, and *vice versa*. The record of the entire response—down movement followed by up—may thus be made on a vertical revolving drum, whose speed is regulated by clock-work. The magnification of the record having been determined previously, and the speed of the drum being known, the response-curve gives the absolute movement and the time-relations of such movement.

Instead of using a vertical drum, it is more convenient to record on the revolving surface of a horizontal drum. The up and down movement of the spot of light may now be converted into lateral, or left and right movement, by means of a second mirror suitably inclined. The finer adjustment of the reflected spot of light may be brought about by means of a milled head with which the second mirror is provided. A photographic record may be obtained by wrapping over the drum surface a sensitised roll-film. But since these movements are comparatively slow, it is easy to obtain the record more simply by following the spot of light with a recording pen, which slides on a horizontal guide-bar, parallel with its movements.

These response-records can be traced on a large scale in the presence of an audience, by the use of the Demonstration Recorder, which consists of a twin-drum, over which is wrapped an endless band of paper to serve as the recording surface (fig. 4). Elastic bands pass over the two drums, one of which is kept revolving by clock-work. The excursion of the spot of light is now followed by means of a sliding ink-well, from which projects the ink-sponge. By this means, the tracing of the response-curve, and its various modifications under the

action of different influences, can be made visible to the whole audience. It is thus possible to obtain records of these pulsatory movements, by attaching the Optical Lever to the leaflet of an intact plant. Or we may detach a petiole,

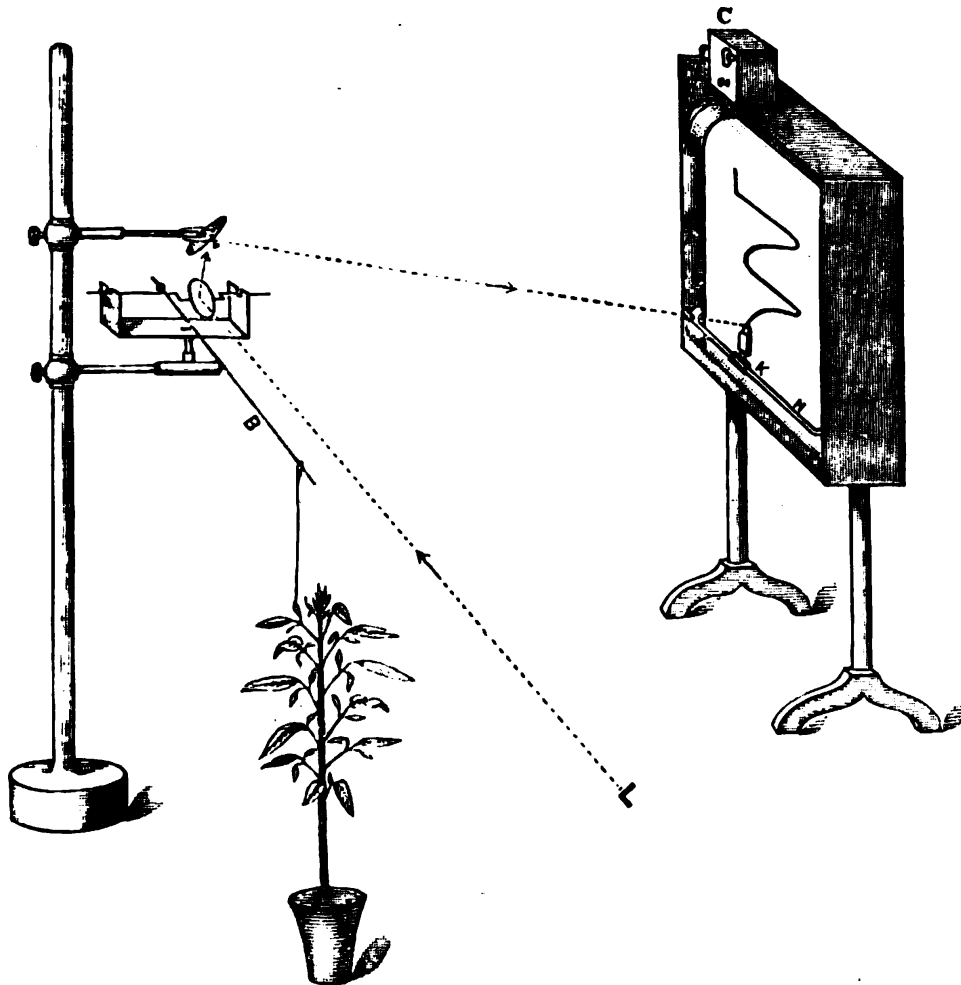

FIG. 4. Demonstration Optical Pulse-Recorder

B, Arm of Optical Lever, attached to moving leaflet ; L, Ray of light, which after two reflections from the two mirrors falls on the recorder ; C, Clock, which keeps twin-drum—on which is wrapped the recording paper—revolving ; H, Horizontal guide-bar ; K, Ink-well, with projecting sponge.

carrying the leaf, and place it in water, in which case it will remain alive as long as a couple of days, executing its accustomed pulsatory movements during a considerable time. The effect of any given agency, say poison, on the living

machinery may now be observed, as graphically indicated in the waning and final arrest of the pulse-record (fig. 5). Or the plant may be killed by passing through it excessively strong electric shocks, after which the occurrence of death will be indicated by the arrest of pulsation (fig. 6).

Thus we see not only the similarity between the pulsations of *Desmodium* and those of cardiac muscle, but also how similarly both are affected by external agencies, such as poison. Later, we shall study the effects of other physiological in-

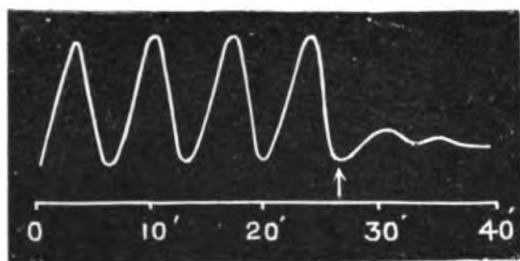

FIG. 5. Death of Plant, and Arrest of Pulsation, by Poison

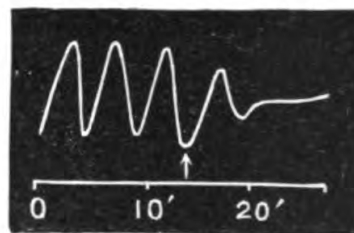

FIG. 6. Death, and Arrest of Pulsation, in Leaflet of *Desmodium* by Strong Electric Shock

fluences on both. In the present chapter, however, it has been my aim to show that these pulse-records give us a reliable indication of the very obscure modifications of the life-processes initiated in the living tissues by various external factors. Speaking generally, we may say that an exciting reagent exalts the pulse, a depressing reagent reduces the amplitude of pulsation, and a poison arrests it permanently, this arrest being death.

In the cases which we have chosen as examples, there is the advantage of a store of latent energy, which maintains the pulsation by providing an internal source of stimulus. This internal stimulation, as will be shown later, is really derived from external sources, the absorbed energy having been held latent in the plant. We shall in the next chapter take up a very much simpler case, in which the plant has no such reserve, but responds immediately to external stimulus.

SUMMARY

A plant, like a machine, responds either to the impact of external forces, or to energy that is latent within.

As the working efficiency of an engine is exhibited by indicator-diagrams, so the physiological efficiency of a living machine may be inferred from the character of its pulse-records.

Agencies which depress the physiological condition of a tissue, also depress its responsive pulsation. At the death of a tissue there is a permanent arrest of pulsation.

CHAPTER II

MECHANICAL RESPONSE TO STIMULUS

Molecular derangement caused by stimulus—Expression in change of form, contraction—Mechanical model—Myograph—Response by differential contraction in pulvinated plant-organs—Longitudinal response in plants—Response of plant to all forms of stimulus—Plant chamber—Practicable forms of graduated stimulus—Electro-thermic stimulator—Stimulation by condenser discharge—Response-recorder—Advantage of counterpoise—Response of *Biophytum* to thermal stimulation—Response to condenser discharge—Absolute measurements of motile effect and of work performed—Effect of load—Definite determination of threshold of response—Determination of variation of excitability by measurement of minimally effective stimulus.

FEW of the phenomena of plant-life are so striking as the conspicuous mechanical movements of certain plants, like *Mimosa*, commonly known as 'sensitive' in contradistinction to 'ordinary' plants. These movements take place in response to various forms of stimulation, such as is caused by mechanical touch or application of heat. It will be shown, however, in the course of the present book that this division of plants into sensitive and ordinary is arbitrary, since all plants are sensitive—that is to say, react to stimulus. The plant, throughout its life, is constantly responding to stimuli, external and internal. Some of its responses are manifested in mechanical movements which are too striking to be overlooked. Others, not so obvious, have passed hitherto unnoticed. But in both these cases changes of form occur in the tissue, in consequence of stimulation. In some instances, owing to conditions which will be explained later, these changes produce little visible effect. In others, the responsive change of form is displayed in a striking manner, owing to certain advantageous circumstances of structure, and to the possession of a magnifying arrangement.

The shock of stimulus causes molecular derangement in the tissue of the plant, and it is this fundamental molecular change that finds expression in mechanical movement. It finds independent expression also in electrical movement. For the conspicuous display of mechanical response certain peculiar structural arrangements are, as has been said, advantageous; but for the exhibition of electrical response, the molecular change itself, which is concomitant to excitation, is the only condition. This subject of the electrical response of plants, however, I treat in detail elsewhere.¹ For the present we are concerned only with the question of mechanical response to stimulus. We have not only to determine the existence of such response, but also to ascertain under what conditions it occurs, and by what means it is brought about.

The whole sequence of molecular events initiated by stimulus and expressed as mechanical response, may be very simply illustrated by means of an india-rubber model. We take a piece of stretched india-rubber, attached to a recording lever. The rubber is enclosed in a tube in which there is also enclosed a spiral of thin German-silver wire, by which the india-rubber may be subjected to the momentary action of heat. The quantity of heat generated is regulated by the strength and duration of an electrical current flowing through the heating wire. This application may be uniform for successive experiments, or increased at will.

Longitudinal response.—The thermal stimulus causes a molecular rearrangement in the substance of the india-rubber, in consequence of which the piece becomes shorter and broader. This sudden longitudinal shortening is recorded by the lever as the first half of the responsive movement. As the substance gradually recovers from the effect of the momentary stimulation, the molecules return to their normal position, with a concomitant restoration of the india-rubber to its original form. During this second half of the process, we

¹ Bose, *Response in the Living and Non-Living* (Messrs. Longmans, Green & Co.). Bose, *Electro-Physiology of Plants*.

obtain the curve of recovery.¹ If we apply similar stimuli successively, we obtain successive responses which are alike (fig. 7). But if stronger stimulus be applied, by means of stronger heating current, the amplitude of response will be correspondingly increased.

In the simple instance which we have considered, the response-record was obtained by taking advantage of the sudden contraction of the india-rubber. In the response of contractile animal muscle, we obtain response-records in exactly the same manner (fig. 8), and such records are known as myographs (fig. 9).

Similar contraction in length, or LONGITUDINAL RESPONSE under the action of stimulus, has been shown by Pfeffer to occur in the

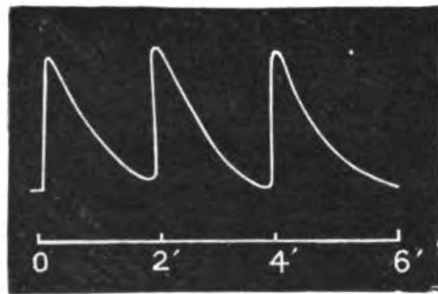

FIG. 7. Response of India-rubber
Thermal stimulus for 1 second at
intervals of two minutes.

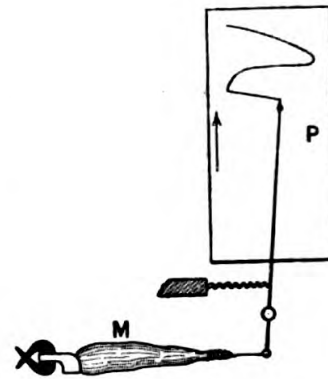

FIG. 8. Mechanical Lever
Recorder

The muscle *M* with the attached bone is securely held at one end, the other end being connected with the writing lever. Under the action of stimulus the contracting muscle pulls the lever, and moves the tracing point to the right over the travelling recording surface *P*. When the muscle recovers from contraction the tracing point returns to its original position. See on *P* the record of muscle-curve.

filament of the sensitive stamens of *Cynerea*. I shall, however, show in Chapter IV. that such longitudinal contraction under stimulus is not unique, but a phenomenon very extensively exhibited by plant-tissues, as seen in the series of uniform responses to stimulation, obtained from the stamen of an ordinary plant, which is here given (fig. 10).

¹ Such models made of catgut and stretched caoutchouc have been used by Engelmann for explaining muscle response.

Differential response.—But the responsive movement in plants is more generally produced by differential contractile movement, and a mechanical model again will clearly show how such movements are brought about. We take two equal strips of unequally contracting substances, which are glued together throughout their length. The two strips consist of ebonite and the relatively more contractile caoutchouc.



FIG. 9. Series of Contractile Responses in Muscle

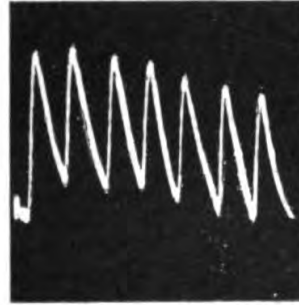

FIG. 10. * Photographic Record of Longitudinal Contractile Response in ordinary Stamens (*Brownia ariza*)

If such a compound strip be held horizontally, with the more contractile element below, and if we subject it to thermal stimulation in the manner described above, the result will be a responsive curvature downwards, the more contractile caoutchouc forming the concave surface. Thermal

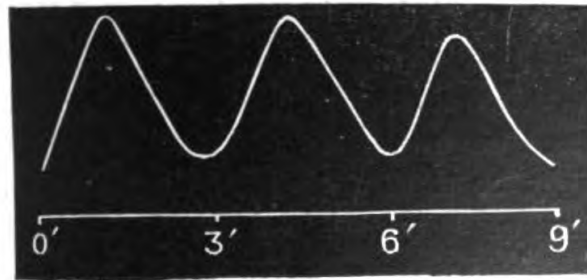

FIG. 11. Differential Lateral Response of Compound Strip
Thermal stimuli applied at intervals of three minutes.

stimulus may be applied, as in the last case, by sending a momentary heating current through an enclosing spiral of German-silver wire, the responses being recorded in the usual manner (fig. 11).

In such cases, where the upper and lower elements are

unequally contractile, we obtain a DIFFERENTIAL RESPONSE, the more contractile becoming concave; and it is evident that such movements must take place in a direction perpendicular to the plane of separation.

Typical cases of mechanical response in plants are obtained from pulvinated organs. A good example of this is found at the insertion of the petiole in *Mimosa pudica*. When such an organ is stimulated, it is the lower half that undergoes the greater contraction, and the leaf is depressed by the concavity thus produced. It is generally assumed that the upper half of the pulvinus is not excitable, but this, as I shall show later, is an error. The responsive movement, however, is due to the differential contraction of the two halves, and, as already explained, takes place in a direction perpendicular to the plane which separates them. Such differential response will be found characteristic of all organs possessing dorsi-ventral differentiation.

Whenever the plant is subjected to any sudden disturbance, the sensitive leaf reacts by a fall, which is brought about by the hinge-like mechanism at the pulvinus. The sudden disturbance which induces the fall constitutes the stimulus. The leaf responds when it is shaken, or cut, or when a prick is applied to it, or when a sudden variation of temperature is produced, as by touching it with a hot wire, or with ice, or when an electrical shock is passed through it, or if it be acted on by certain chemical reagents, or a beam of strong light be thrown on it. All these constitute the various forms of stimuli—mechanical, thermal, electrical, chemical, and photic.

We have next to study the relation between the intensity of the stimulus and the extent of response under varying conditions; that is to say, we have to determine the 'threshold of response,' in other words, the minimum intensity of stimulus that will be just sufficient to initiate reaction. We have then to observe the repeated response of the plant to repeated stimulation, whether uniform or gradually increasing. We have to detect the signs of fatigue if there be any, and

discover after what period of rest this disappears. We have also to record the exact time-relations of these phenomena. And further we have to study the effects of various external agencies in modifying the response.

In order to carry out these investigations, it will be necessary first to arrange for placing the plant under suitable conditions for experiment. The next point is the devising of facilities for applying a stimulus of known intensity, which can be repeated, or increased by definite amounts, at will. And, lastly, there must be some means of obtaining an exact record of the response, from which the absolute movement of the responding organ and its time-relations may be deduced.

Experimental plant chamber.—As regards the first of these, it is advisable to have a special plant chamber within which the specimen can be subjected to the necessary conditions. This chamber may consist of a base-board and a movable cover. The framework of the latter is of wood, with glass panes. In order to give easy access to the plant during experiment, one side of the cover has a hinged window. The recording Optical Lever is placed inside the chamber, and the glass cover protects the recorder from any accidental disturbance caused by air-currents.

In connection with this, it is also important to provide arrangements for producing changes of temperature, and maintaining the changed condition uniform, for the required length of time. This is most satisfactorily accomplished by means of a heating coil placed inside the chamber, the temperature being regulated by suitable adjustment of the electrical current, sent into the coil through proper electrodes. Other necessary accessories consist of appliances for the purpose of stimulation, and facilities by which a constant current can be made to flow through the tissue, in experiments on the effect of electric currents on the excitability of plants. Details regarding these will be given later. The plant may be maintained in favourable humid conditions by placing wet blotting-paper inside the chamber (fig. 12).

The most important question with regard to the application of suitable stimulus is, as has been said, that it should be capable of exact measurement, of uniform repetition, and of definite increase or decrease at will. Another point which must be borne in mind is that the application of stimulus should not, by causing injury, change the excitability of the organ. As, moreover, a magnified record of the responsive movement is to be made immediately after the application, any stimulus which causes the slightest jar must necessarily

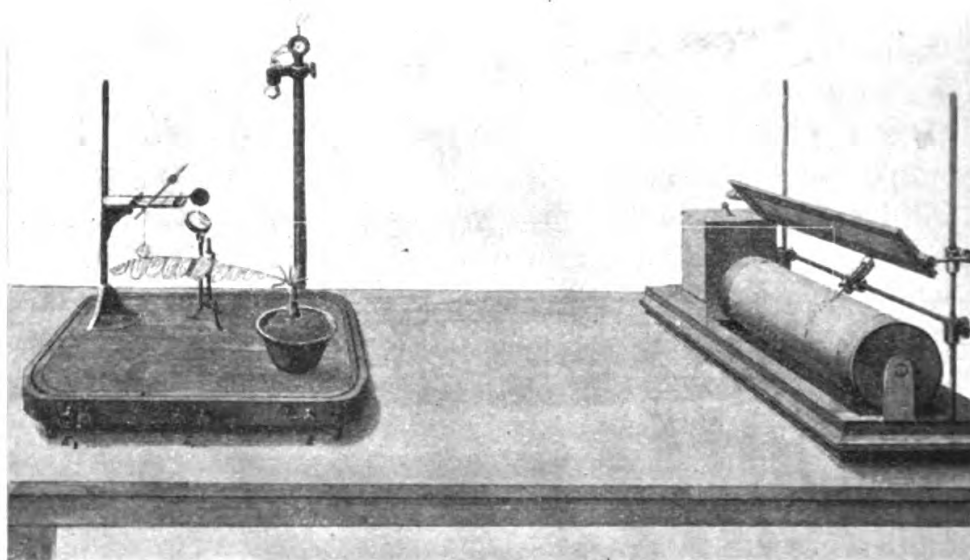

FIG. 12. Plant Chamber and Recorder
The glass cover is not shown.

be avoided. And for these reasons the mechanical form of stimulation is inappropriate to the investigation. The three most perfect modes of stimulation which I have been able to render practicable are, then, the thermal, the electrical, and the stimulus of light. The action of the last will be described in detail in another chapter, and we shall for the present confine our attention to the first two.

Electro-thermic stimulator.—Thermal stimulus may be applied very easily by touching the plant with a hot wire, but

it is difficult by this means to ensure the uniformity of successive stimuli, inasmuch as the wire cannot be heated repeatedly to the same temperature, or made to touch the same point, many times in succession, with an equally effective contact. This difficulty is removed by means of what I have named the ELECTRO-THERMIC STIMULATOR. This consists of a thin M-shaped wire of platinum, with thick copper leads. It is slipped over the petiole which carries the sensitive leaflets. By now sending through it a current of definite intensity and duration, we can raise its temperature to any point we wish, and thus secure the application of a known intensity of stimulus at will. The elasticity due to the peculiar form of the thermal stimulator gives a definite and constant pressure of contact (fig. 13).

The observer applies the stimulus with his left hand, by pressing a tapping-key which is interposed in an electric circuit, for a definite short time.

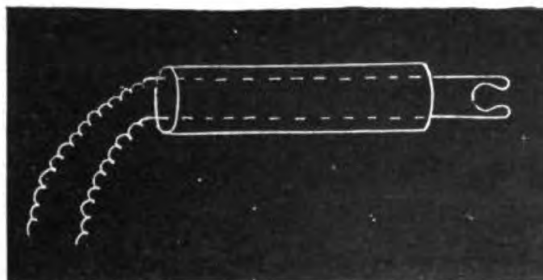

FIG. 13. The Electro-thermic Stimulator

With his right hand, he records on the revolving drum the exact moment of this application. This mode of thermic stimulation is, as will be shown presently, very efficient.

Electric stimulation.—I have been able, however, to employ a mode of stimulus still more perfect, that, namely, of the electrical discharge from a condenser. Other forms of electrical stimulation may be used, such as those given by means of constant or induction currents. But these are liable, not only to cause more or less permanent internal changes by polarisation, but also to induce fatigue of the tissue. It will be shown in a later chapter that, on making the circuit, excitation takes place at the point where the current leaves the tissue—that is to say, at the kathode—and not at the anode, or point of entrance. By appropriate connections shown in the diagram (fig. 14), the point to be excited can be made

C

kathode during 'charge,' when the key is pressed. When the key is released, the circuit is 'discharged,' and the current flows in the opposite direction.

The given point B is, as has been said, excited by being made kathode at the moment of charge. The immediately succeeding discharge produces no exciting effect, but it wipes off any residual polarisation effect caused by charge. The plant-tissue is thus maintained in as completely normal a

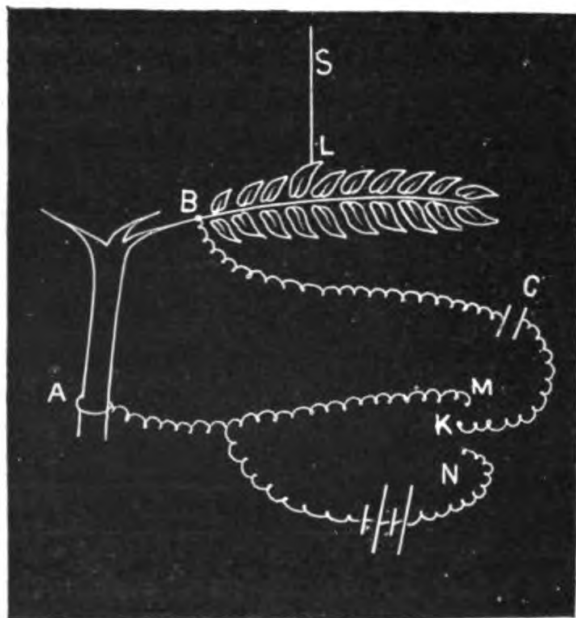

FIG. 14. Diagram of Connections for Stimulation by Condenser Discharge

Pressure of key K charges the condenser C through the plant. Release of key brings it in contact with M, discharging the condenser through the plant. L, responding leaflet attached to recording lever by thread S.

condition as possible. The excitation produced in the plant by current to or from the condenser, I shall, for simplicity, designate as 'stimulation by condenser discharge.'

In the course of the present chapter we shall study the response of the leaf of *Mimosa*, shown by its fall, and also that of other sensitive plants, exhibited by the closure of the leaflets, as in the case of *Biophytum sensitivum*. One difficulty encountered in obtaining successive responses, in these latter cases, was due to the fact that the responding

leaflets, after each downward response, would sometimes remain persistently closed, for an indefinite period, thus preventing the continuation of the experiment. In cases where the leaflets are completely closed, one naturally regards the position as one of fatigue, or complete insensitiveness, because no further mechanical response is then obtainable. This depressed position, however, may not be indicative of total want of sensibility, for the apparent absence of response may really be due to the fact that further closure of the leaflets is a mechanical impossibility. We may consider an analogous instance in the case of animal tissues, muscle floating in mercury for example. The tissue remains persistently contracted after a single stimulus, and further response is impossible. But if, again, the muscle be stimulated while under tension, it responds to each stimulation, the process of recovery being aided by the external tension.

Practical importance of counterpoise.—Acting on this idea, it appeared to me that if we applied an external tension, the restoration of the leaflet to the natural outspread position might be helped, and the difficulty solved of obtaining the uniform repetition of effects of successive stimuli at brief and regular intervals of time. I therefore placed a small sliding counterpoise on that arm of the lever which was not attached to the leaflet. This was found to fulfil its purpose. For in observing the effects of successive stimuli on different leaflets, I found that while neighbouring leaflets, not under tension, closed up after a few stimulations, and gave no further response, the leaflet which was attached to the lever, and which was under some slight tension, recovered its normal outspread position in the course of three to five minutes, and continued to respond in a normal manner to a long series of successive stimuli.

We shall now proceed to observe the actual responses obtained. The object here is not to investigate the peculiar or specific reaction of any one sensitive plant in particular, but the effects found universally among motile plant-organs. The occurrence of such effects in plants exhibiting all

c 2

degrees of mechanical sensibility—from those in which it is shown in an extreme degree, to others again in which it is apparently almost non-existent—will be demonstrated in this and succeeding chapters.

In order to study the responsive movements of plants, we may take either the leaflets or the main petiole of *Mimosa pudica*. The leaflets, however, in this case are so excessively sensitive that even the contact for experimental adjustment is sufficient to produce a closure from which they do not recover for a considerable time. The pulvinus of the main petiole, on the other hand, is considerably less sensitive. Of intermediate sensibility are the leaflets of *Biophytum sensitivum*, which on the whole furnish the most suitable specimens for the general purposes of these experiments. This plant, which is known to be sensitive, grows in a wild state near Calcutta, and is so common as to be considered a weed. It is a low-growing herb, with simply pinnate leaves, each bearing from ten to sixteen pairs of leaflets. A better specimen could hardly perhaps be found for the exhibition of some of the most important characteristics of mechanical response. It is not, under ordinary conditions, excessively sensitive. A gentle touch does not, as a rule, produce the closing effect, but under specially favourable circumstances its sensitiveness may equal, if not surpass, that of the *Mimosa* leaflets. The closing of the leaflets takes place not upwards as in *Mimosa*, but in the downward direction. I shall presently give details of the response obtained with *Biophytum*. But as this plant is not universally obtainable, and as it flourishes only for a short season, during and after our tropical rains, it may be best first to give an account of experiments made on the more generally accessible leaf of *Mimosa*.

Response of *Mimosa*.—As the responsive movement of the leaf of *Mimosa* is of considerable extent, no magnification is necessary for the record. Indeed, on the contrary, for the illustrations in the present work, the records had frequently to be taken on a reduced scale. This was accomplished

by attaching the leaf to the long arm of the recording Optic Lever, and shortening the distance of the recording surface. The records given in figs. 15 and 16 were automatically obtained by the impression of the moving spot of light on a sensitive film wrapped about the recording drum. The leaf was excited by a single strong induction-shock. In order to obtain the complete curve of response and recovery—the double process being accomplished in the course of about seven minutes—the first record was taken on a slowly moving drum. For the detailed study of the characteristic time-relations of the first part of the curve, again, two more records were obtained, one with a moderate (fig. 15) and the

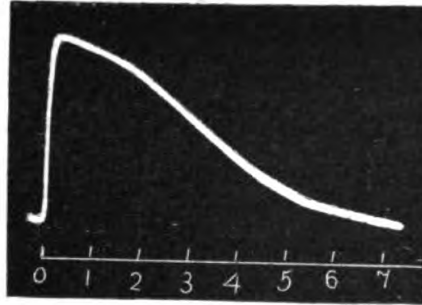

FIG. 15. Photographic Record of Response and Recovery of *Mimosa*, taken on a slowly moving drum. Record shows actual movement reduced to one-third.

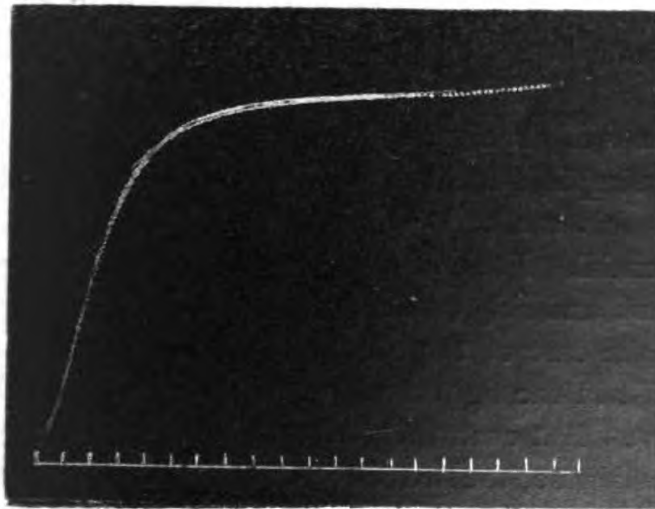

FIG. 16. Photographic Record of Response in different specimen, taken on a faster-moving drum, showing only first part of the curve. Each division of time-scale = $\frac{1}{5}$ second.

other with a rapid speed of drum (fig. 110). The last of these enables us to obtain time-measurements which are accurate to less than $\frac{1}{50}$ of a second. The method by

which these rapid records are obtained will be described in Chapter XXII.

From records obtained on a fast-moving drum, with a fairly average specimen of *Mimosa*, it is found that the leaf does not respond to stimulus immediately, there being a latent period of $\frac{2.4}{100}$ of a second before it begins to move. The maximum fall is attained in the course of 2 seconds after the shock. After attaining the position of maximum depression, the leaf remains in its contracted position for a further period of about thirty seconds. It then begins slowly to recover, and perfect recovery takes place in the further course of six minutes. The record given was obtained from the leaf of a plant which was one year old, and in the summer season. It will be remembered that these responsive curves are modified by the physiological condition of the plant ; thus, for example, the time taken by the leaf of a vigorous young plant for recovery may be as short as four minutes, whereas an older specimen in winter may require as long a period as eighteen minutes. We may thus obtain from the record an idea of the physiological condition of the specimen.

By means of photography the taking of the record is made extremely simple, but there are certain disadvantages inseparable from this method, which render the devising of other means essential. For example, the motile sensibility of plants like *Mimosa* and *Biophytum* is profoundly modified in darkness. In the case of the records given, the plants have been kept outside in the light, and brought in immediately before experiment. But even then, after remaining in the dark for half an hour or so, the leaves of *Mimosa* become abnormally erected, till it can hardly be believed that the plant is sensitive, for it often becomes irresponsive to the hardest blow. *Biophytum* leaflets, again, in the same circumstances undergo closure. For these reasons, long-continued experiments in a dark room are an impossibility. Various sensitive plants, again, flourish only for a short-lived season, and during that period some hundreds of experiments have to be carried out.

This necessitates some method of record more expeditious than that of photography.

Fortunately, the responsive movements of these sensitive organs are relatively slow, usually requiring several minutes for completion. And it is quite easy to follow the excursion of the responding spot of light, with the recording pen, on a horizontal drum. There are some few special investigations, such as those on exceedingly short latent periods, in which automatic records by photography are a necessity, but for the majority of the records the second method is all that is required. By the latter means, moreover, we overcome the serious difficulty occasioned by the variation of sensibility which the plant undergoes when kept long in a dark chamber. When the second method is employed, the specimen may be placed in a well-lighted and well-ventilated room, and under these conditions it is found to maintain its sensitiveness unchanged for a considerable length of time. The fact that the spot of light reflected on the drum becomes inconspicuous in the surrounding daylight is overcome by placing in front of the recording drum a special hood with a long horizontal slit. The back of this hood curves over the head of the observer, and the spot of light then appears very bright.

Response of *Biophytum*.—I shall next deal with the responses obtained from *Biophytum*. In fig. 17 are given two successive responses to two successive thermal stimuli. It will be noticed how uniform these responses are. The up-curve represents the fall of the leaflets, and the subsequent down-curve of the response exhibits its gradual return to the normal outspread horizontal position. An abnormal erectile twitch will be noticed at the beginning of each of these responses. This effect is usually present when a stimulus of whatever nature is applied at a distance from the responding leaflet. Its cause will be explained later. It should be stated here that stimulus was in this case applied at a distance of 35 mm. from the responsive leaflet, and that the true excitatory reaction, by the depression of the leaflet, took place fifteen seconds after the application. In

other words, the excitation travelled the intervening distance with a speed of 2.3 mm. per second. The abnormal erectile

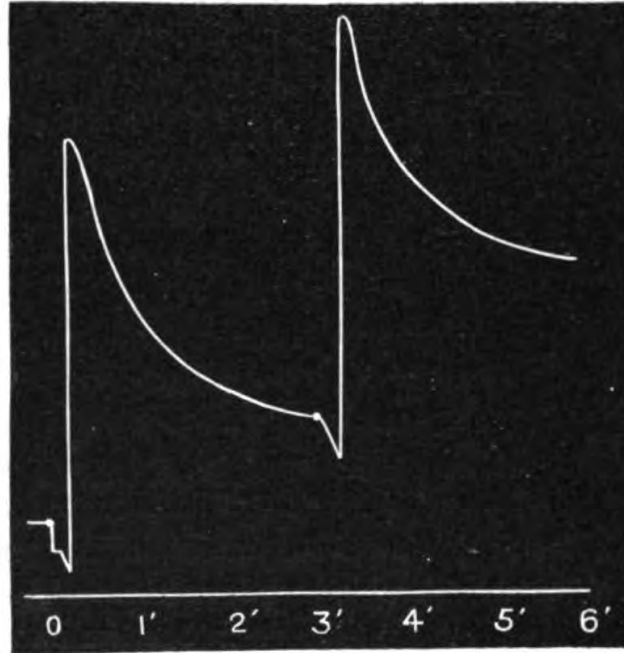

FIG. 17. Response of *Biophytum* to Thermal Stimulation
Stimulus was applied at some distance from the responding leaflet.
Thick dot represents moment of application of stimulus.

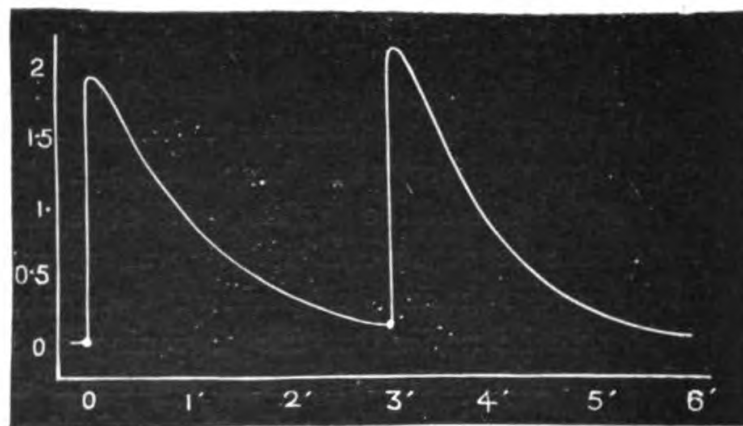

FIG. 18. Response of *Biophytum* to Electric Stimulation
Stimulus was applied directly on the pulvinus. Ordinate represents absolute
movement in mm.

effect, however—due, as will be explained later, to hydrostatic disturbance—took place almost instantaneously.

The next figure (fig. 18) gives successive responses of *Biophytum* to condenser discharge, the pulvinus of the leaflet being directly excited. It will be noticed that in this case of direct stimulation, no abnormal erectile twitch is present. From the magnification of the record the absolute value of the movement is known, and in the present case it was 1.88 mm. The force exerted by the leaflet during its responsive movement was found equivalent to that exerted by the weight of 17 milligrammes. The total work performed by the leaflet during each responsive movement is therefore nearly equal to 1,600 millimetre-milligrams.

Effect of load.—In order to observe the effect of load on the response-curve, I added a slight additional counterpoise to the other arm of the lever. The record (fig. 19, *a*) shows the response-curve when the acting load is the weight of the lever; (*b*) shows the effect of the additional load. It will be seen that while the height of the responses was diminished, yet the period of recovery was very much reduced, from five minutes to less than three, under the increased load.

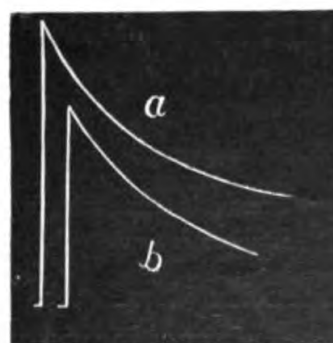

FIG. 19. Effect of Load (*a*) without, and (*b*) with, additional load

Isometric record.—The method of observing response employed in the foregoing results was that of recording the movement of the leaf. Similar methods are known in Animal Physiology as *isotonic*. There is, however, an interesting method corresponding to that known in Animal Physiology as the *isometric*—where, in obtaining records of responses, actual movement is almost abolished. The contraction of the more excitable half of the pulvinus exerts a certain tension, or pull. The object, under the isometric method of experiment, is to obtain records of varying responsive tensions of excited tissues, the physical movement being at the same time restrained. This I have been able to accomplish,

in the case of plant response, by the construction of a spiral spring-recorder, the movement of whose index is approxi-

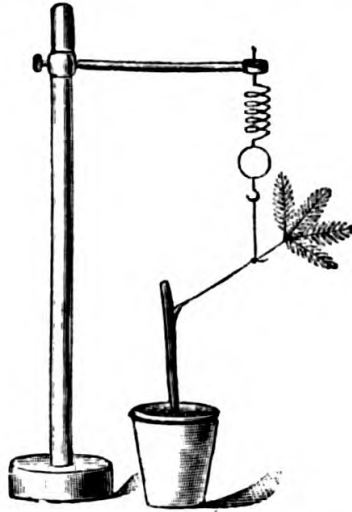

FIG. 20. The Spiral Spring-Recorder

The leaf is practically prevented from moving. The tension exerted by excited leaf causes rotation of index or mirror.

mately proportional to the tension. The recorder is constructed of a fine flattened spiral spring. Springs of this description have the peculiarity that, when they are stretched by tension, the free end of the spiral rotates round the axis of the spring. A slight rotation may be magnified by means of a mirror and reflected spot of light (fig. 20). This arrangement is specially appropriate to the leaf-stalk of *Mimosa*, where the pull exerted by the excited leaf is considerable. Fig. 21 gives the isometric response of *Mimosa*.

Minimally effective stimulus in *Biophytum*.—

It is well to mention here that at least in the case of *Biophytum* the minimal intensity of stimulus necessary to cause response

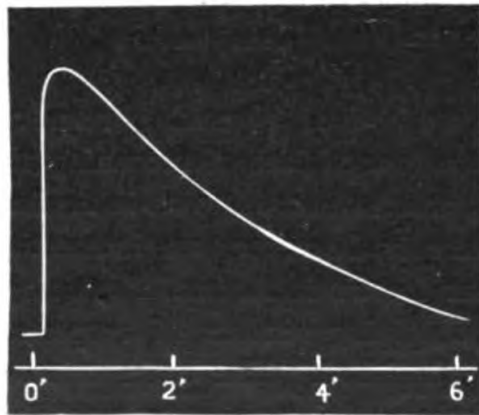

FIG. 21. Isometric Response of *Mimosa*

is very well defined. With a certain specimen for example, when the plant was excited by the discharge from a .01 microfarad condenser, charged to seven volts, there was no response. But when the condenser was charged to nine volts the discharge always produced a large and definite response.

Charging of the condenser to nine and seven volts alternately would in the one case produce response, and in the other none. If now, by the action of an external agency, the

excitability of the tissue be increased, the seven-volt condenser charge, before inadequate, will become adequate. Conversely, if by the action of an external agent the excitability of the tissue be depressed, the nine-volt charge, which was formerly effective, will become now ineffective. I find, for instance, that lowering of the temperature will, by increasing molecular sluggishness, reduce excitability. Hence a minimally effective stimulus becomes ineffective when the tissue is cooled. Conversely, a rise of temperature produces the reverse effect, namely, increase of excitability. This was seen in a particular experiment with *Biophytum*, where the minimally effective stimulus necessary at 30° C. was found to be reduced to two-thirds when the temperature was raised to 35° C.

Having thus obtained a reliable stimulus, whose value may be measured with precision, and which is capable of being repeated, and having also discovered an arrangement by which the effect of a given stimulus is invariably exhibited by a uniform response-record, we are now in a position to attack various physiological problems, as regards the influence of given external agencies on the conductivity and excitability of the plant-tissue.

SUMMARY

Longitudinal responses are given by radial organs.

A differential response, causing lateral movement, is given by an organ in which the excitability of one half is different from that of the other; and the movement takes place in a direction perpendicular to the plane of separation of the two halves. Such responses are characteristic of dorsal-ventral plant-organs.

In the responses of the sensitive organs of plants we notice: a short latent period; a period during which the excitatory movement attains its maximum; and a period of slow recovery.

When the stimulus is applied at a distance, a preliminary abnormal erectile twitch is occasionally observed, which is

due to hydrostatic disturbance. The true excitatory response takes place later.

Besides the isotonic response, obtained by recording the actual movements of the excited leaf, it is also possible to record the isometric response where the movement is restrained, and the variation of tension caused by the contraction of tissue is alone recorded.

The intensity of a minimally effective stimulus in the case of *Biophytum* is definite. This value undergoes appropriate variation with the variation of excitability of the organ.

CHAPTER III

ON THE UNIVERSALITY OF SENSITIVENESS IN PLANTS AS DEMONSTRATED BY MEANS OF ELECTRICAL RESPONSE

Arbitrary classification of plants into sensitive and ordinary—Method of electromotive variation for detecting state of excitation—Hydraulic model—Excitation of vegetable tissue, like that of animal tissue, induces galvanometric negativity—Methods of direct and transmitted excitation—Electrical and mechanical response alike record molecular derangement and recovery—Similarities in simultaneous record of mechanical and electrical response—True excitation has a concomitant negative turgidity-variation, negative mechanical response or fall, and galvanometric negativity—These are true physiological responses, and are abolished at death—Abnormal positive mechanical and electrical responses brought about by positive turgidity-variation—Direct and indirect effects of stimulation—Discrimination of differences of excitability by electric test—Excitability of plant-tissues in general—Responsive power characteristic of matter.

WE have seen that when stimulus is applied to a sensitive organ like the pulvinus of *Mimosa* there is a fall of the leaf, which fall is due to the excitatory contraction of the more excitable lower half of the pulvinus.

Ordinary plants are said to give no motile indications, hence they are usually regarded as insensitive.¹ It is difficult, however, to conceive that while the protoplasm of certain plants reacts to stimulus, that of others should not do so. On the other hand, it may be that the absence of mechanical response in these ordinary plants is not due to any want of excitability, but rather to the fact that conditions favourable to the conspicuous exhibition of motile effects do not in

¹ Vines has already drawn attention to the possibility of error here: We must be careful not to assume that irritability is restricted to growing and to motile organs. For all we know to the contrary, it is possessed by the protoplasm of all plant organs, and if in any case the action of a stimulus is not followed by a responsive movement, we must, before we assume the absence of irritability, assure ourselves that the structure of the organ is such that a movement is a mechanical possibility.—Vines, *Physiology of Plants*, 1886, p. 372.

such cases exist. What these conditions are will be detailed in the next chapter, where it will also be shown that excitation of an organ may take place, even where there is little mechanical indication of the fact, owing to antagonistic and balanced contractions.

Electrical response.—It is my intention, in the course of the present work, to offer a complete demonstration of all the phenomena of excitation in plants, by means of mechanical response alone. But the conclusions to which we shall be led by the study of this response will receive irrefragable support, if they can also be established independently by some mode of investigation altogether different. Such a mode of inquiry, namely the electrical, and the conclusions to which it leads, will be fully described in the companion volume to this work, on the *Electro-Physiology of Plants*. Meanwhile it is convenient in this place to enter upon a short elucidation of the principle of that method, in order that we may be able, while considering the results of mechanical response, to make casual references to confirmatory results of independent observations obtained by means of the electrical method.

It has been said that under the action of stimulus excited cells undergo contraction, and that owing to the consequent expulsion of water, the turgidity of the tissue is diminished. Thus one expression of the molecular change induced by stimulus is a negative variation of turgidity. But this molecular change may also be detected by means of other concomitant physical changes. For instance, the electrical level or potential of a given point may, owing to the excitatory molecular change, undergo variation, relatively to another point which is unexcited. A hydraulic model will serve to make this point clear (fig. 22).

Let us imagine a flexible pipe of india-rubber, with bent ends of glass-tube, filled with water, and held in the middle by a clamp C. It is also supported in the stable horizontal position by spiral springs. If a single blow, say upwards, be now given to the end A, the level of the pipe at that end will be raised, and there will be a resultant flow of water from

A to B, or away from the struck end. The intensity of the current is determined by the height to which the struck end A has been raised, and this again depends on the intensity of the blow. Hence the intensity of the current is a measure of the intensity of the stimulus or disturbance. The flow subsides with the return of the pipe to its equilibrium position. If the pipe had been disturbed throughout, the level would have been raised equally at both ends, and there would have been no flow. The object of the clamp is, therefore, to confine the disturbance to one side. If the blow had been

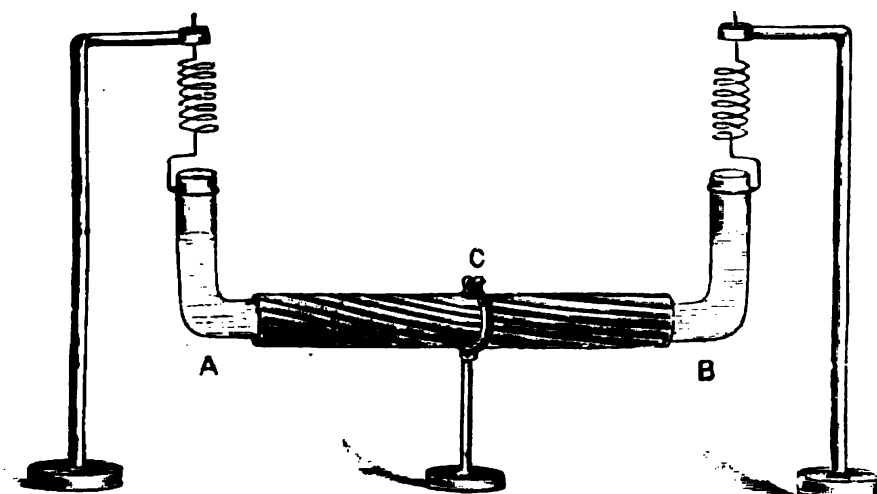

FIG. 22. Hydraulic Model for Explanation of Electric Response
When an upstroke is given to A, a responsive current flows from A to B,
and *vice versa*.

given on the B side, the direction of the responsive flow would have been reversed.

The principle of electromotive response in plants is exactly similar to this. The plant tissue is clamped at C (fig. 23), and a stimulus is given at one end, say A. The electrical level of that side is now found to be raised, it becomes electro-positive, or like the copper in a voltaic combination. The responsive current thus flows in the tissue from A to B, or away from the excited point. In the external circuit containing the galvanometer, it flows, of

course, in the opposite direction, that is from B to A.¹ The excited point A is thus electro-positive, but in physiological text-books it has been ambiguously termed negative. In order therefore to keep touch with the older terminology and yet avoid the implied error, I shall refer to the excited point as '*galvanometrically negative*.'

If the B end of the specimen be now excited, the direction of the responsive current will be reversed. With greater intensity of stimulus the electrical response will be found correspondingly increased. The record of such responses is

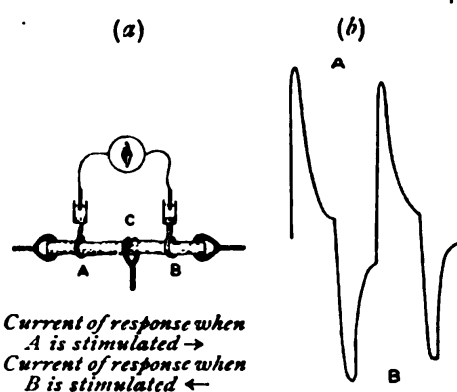

Current of response when A is stimulated →
Current of response when B is stimulated ←

FIG. 23. Electrical Response in Plant by Method of Block

- (a) The plant is clamped at C, between A and B.
(b) Responses obtained by alternately stimulating the two ends. Stimulation of A produces upward response, and that of B downward.

obtained on a revolving drum, by following the deflection of a spot of light reflected from the galvanometer mirror in a manner precisely similar to that employed with the Optic Lever (fig. 24).

Method of transmitted stimulation.—In the simple case just described, the tissue was stimulated directly and locally at the end A, say by torsional vibration. There is, however, another *transmitted* stimulus

which a stimulus,—say by application of cut, or hot wire or electrical shock,—is given at a point X some distance away, say to the right. The excitation now travels with a velocity characteristic of the specimen, and when it reaches the proximal electrode produces galvanometric negativity of that point. The interval of time which elapses between the application of stimulus and response will therefore depend on the velocity of transmission and the distance of the point

¹ The failure to understand this point clearly has been the source of many grave errors in some physiological text books. From the fact that the current in the external circuit is seen to flow in the direction of A, it has been erroneously supposed that that point is negative, or zinc-like. See Bose, *Response in the Living and Non-Living*.

of application. It will also be remembered that the state of excitation is attended by an expulsion of water, or negative turgidity-variation. After causing galvanometric negativity of the proximal contact, the excitation may reach the distal, and bring about reversal of response, thus constituting a

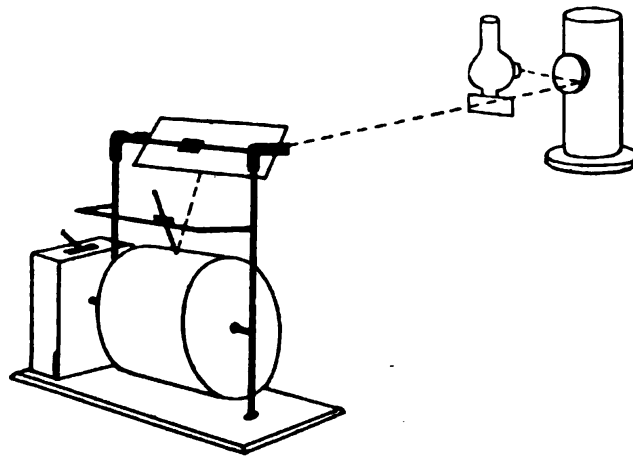

FIG. 24. Electric Response Recorder

diphasic variation. If, however, the distal point be very far, the excitation may by transmission through the long tract become so enfeebled as to produce practically no effect at

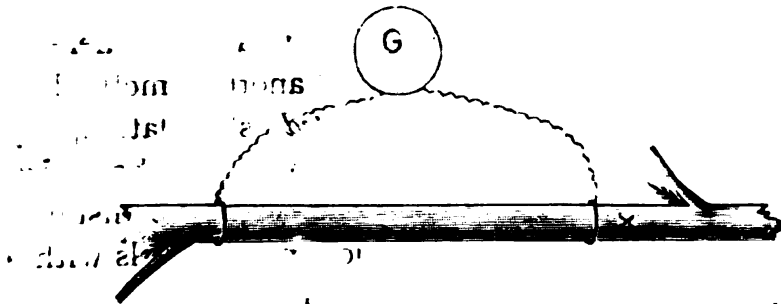

FIG. 25. Method of Transmitted Stimulation

Stimulus applied to the right at x. Excitation reaches right contact first, causing galvanometric negativity of the point.

that point, in which case we obtain only the monophasic response of the proximal point.

Simultaneous mechanical and electrical events, ensuing on excitation.—We may prove that these electrical responses are undoubtedly signs of excitation, by choosing

D

for the electrical experiment a plant in which the state of excitation is independently manifested by mechanical response. If now these electrical and mechanical responses be indeed only two different expressions of the same thing—that is to say, of a molecular disturbance and recovery which is concomitant to excitation and recovery from excitation—then we should expect that, on taking a simultaneous record, the two responses would be shown to be initiated at the same moment, and to bear some general resemblance to each other. In the following record it will be seen that this is found to be the case (fig. 26).

To recapitulate: let us take the concrete example of the *Mimosa* leaf. When the pulvinus is excited, owing to the

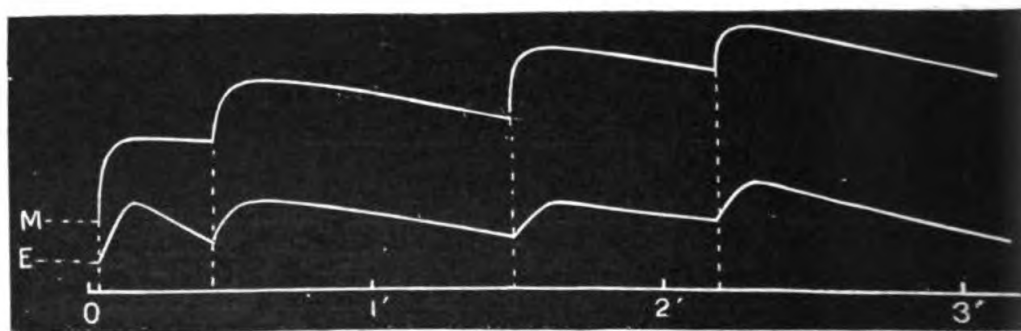

FIG. 26. Simultaneous Mechanical (M) and Electrical (E) Responses in *Biophytum*
These responses are seen to take place at the same moment.

molecular change induced by stimulus, there is an expulsion of water, or negative turgidity-variation, and in the absence of restraint this is attended by the normal negative mechanical response, or fall of the leaf. If, now, electrical connections have been made, one with the pulvinus, and the other with a distant point on the stem, it will be found that the excitatory change is attended by a strictly concomitant electrical change, the current of response flowing away from the excited point, which in other words becomes galvanometrically negative.

All these events will perhaps be more easily realised if we remember that excitation, in the typical case of *Mimosa*

gives rise simultaneously to (*a*) contraction of the cells, with concomitant negative turgidity-variation; (*b*) negative mechanical response, or fall of the leaf; and (*c*) galvanometric negative variation. Had the leaf been physically restrained by any means, the mechanical response would have been prevented, although the negative turgidity-variation concomitant to excitation would have taken place just the same. But this internal change would have been imperceptible, and in that case we could still have detected the effect of excitation by means of the electromotive response. As a matter of fact it is found that the electrical response always takes place in answer to effective stimulation, even in cases where the mechanical response is rendered impossible. We thus see that galvanometric negativity is a certain indication of the excitatory contraction of a cell, whether or not the effect of such contraction be outwardly manifested by mechanical movement. The detection of the state of excitation by the electric test is thus unailing, and of universal application. By the employment of this electric mode of investigation, I have shown that not sensitive plants alone, but every plant, and also every organ of every plant, is excitable.

True excitatory negative versus hydrostatic positive variation.—It has been supposed that the galvanometric negativity consequent on stimulation may be due to mechanical movement of water in the tissue. But I have shown that this cannot be the case. For while it is true that the production of water-movement by sudden forcing of water into a tissue does cause electrical variation, yet it must be noted that the sign of this electrical change is always one of galvanometric positivity, which is opposite to that of the true excitatory response. The intensity of the true negative electrical response, moreover, varies with the physiological activity of the tissue, and is abolished with its death. The electrical variation due to mere water-movement, however, may take place even in a dead tissue, and is, as has been said, of positive sign.

If a piece of living tissue be subjected to *direct* stimula-

tion—that is to say, be locally disturbed, say by torsional vibration—two effects will be produced: first, the negative turgidity-variation, which is the true excitatory effect, with its attendant negative electrical variation; and, second, the electrical effect due to hydrostatic disturbance or water-movement, which is positive. Of these two opposed electrical effects, the first, or true excitatory variation, is generally speaking much the stronger. It therefore completely masks the second, or effect of water-movement, and the resultant response is the normal negative variation. The water-movement effect may, however, be unmasked by killing the tissue, and then applying the same torsional vibration as before. The result is now a positive electrical response.

Or the positive effect may be made to exhibit itself separately, under favourable conditions in a living tissue, by the method of indirect stimulation, that is to say, by the application of stimulus at a distance. When such a distant point is stimulated, there is a sudden expulsion of water from that point, due to stimulation. This gives rise to a wave of increased hydrostatic pressure (with its attendant positive turgidity-variation), which travels with a relatively great velocity. The true excitatory variation, travelling at its slower rate, reaches any given distant point much later. The two effects ought thus to be divided from each other by some interval of time.

We should therefore expect on stimulation of a sensitive plant to find the hydrostatic disturbance, with its attendant positive turgidity-variation—reaching the distant motile organ the earlier of the two. And since the negative turgidity-variation due to excitation causes a fall of the leaf, the positive turgidity-variation due to hydrostatic disturbance should be expected to produce an abnormal positive or erectile movement, and the same positive turgidity-variation should also find a simultaneous electrical expression in the abnormal positive response. The true excitatory response—with its attendant negative turgidity-variation—should cause, later the normal negative mechanical response,

and also the normal negative electrical response. We have already seen, in fig. 17, an instance of this abnormal positive followed by the normal negative mechanical response, in experiments with *Biophytum*. This abnormal positive response, being a matter of the intensity of the blow delivered by the water-movement, can only exhibit itself under favourable conditions. It is thus possible in mechanical response to have either the normal response preceded by the abnormal, or the normal response alone. But whenever we have an abnormal mechanical response, due to positive turgidity-variation, we have also simultaneously an abnormal positive electrical response. In fig. 27 is shown a simultaneous record of the two, in which there is a preliminary abnormal positive mechanical response, and a synchronous positive electrical response, followed in both cases by the normal responses.¹ It should be stated here that this positive turgidity-variation, which is referred to as abnormal, is of very great importance, and will be seen in Chapter XXX. to be directly responsible for growth. It will be found

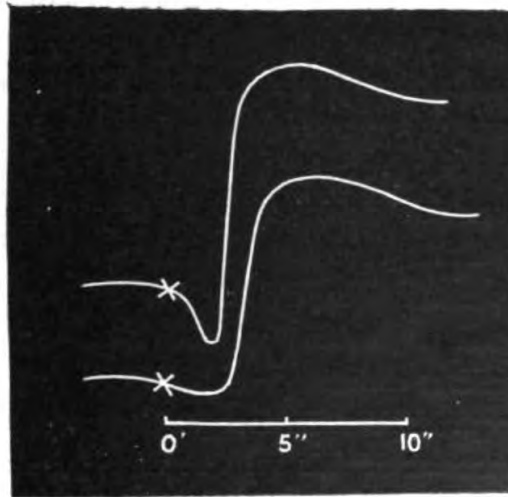

FIG. 27. The Abnormal Positive preceding the Normal Negative in Mechanical and Electrical Responses in *Biophytum*
 × represents the moment of application of stimulus. The upper is the mechanical and the lower the electrical record. The records downward indicate erection of the leaf or galvanometric positivity.

¹ It must be understood that this positive electrical response, being dependent on the excitatory expulsion of water at a distant point, is, in a certain sense, a physiological response. For it is the excitability of that distant point which determines the positive turgidity and concomitant positive electrical variation of the point under examination. The contraction of the excited point gives rise to a hydrostatic disturbance, by which a movement of water is brought about. Such a disturbance, then, will be indifferently designated as the hydrostatic, or hydraulic, wave.

helpful in the future if we uniformly distinguish (1) the true excitatory or normal as the *direct*, and (2) this positive or abnormal as the *indirect* effects of stimulation.

Discrimination of differences of excitability by electric test.—Not only does the electrical response enable us to detect the state of excitation, but I have been able further to devise an electrical test by which differences in the natural excitability of two points might be distinguished. The demonstration of the existence of two electrical responses, one of which alone, namely the negative, constitutes the true excitatory effect, is of much theoretical interest. For the hydraulic, or positive electrical effect, has been mistaken for the true excitatory response in plants. As the excitatory effect in animal tissues, moreover, was known to be negative, this fact was supposed to indicate a difference between the protoplasmic reactions of animal and vegetable. But the experiments which I have just described conclusively prove that such a difference does not exist, the sign of response in animal and vegetable being the same. They offer us an explanation, further, of the source of error. A more detailed account of this subject will be found in my forthcoming work on the Electro-Physiology of Plants.

Many of the motile phenomena of mechanical response which we shall have to study in the course of the present work are modified by differences of excitability at different parts of a tissue. In the case of the primary pulvinus of *Mimosa* for example, we can see how the responsive fall is brought about by the evidently greater excitability of the lower half of the pulvinus. But in organs which apparently exhibit little motility, it is impossible from inspection to know whether all parts of the tissue are equally excitable, and, if not, which parts exhibit the greater excitability. Such variation of excitability is often due to invisible molecular differentiation, and eludes visual scrutiny. Fortunately, as already said, I have been successful in devising a mode of electrical investigation by which this differentiation is detected with the greatest certainty. This method will be

found fully described elsewhere, but the results may be summarised as follows : On simultaneous excitation of two points, the current of response flows in the tissue from the more excitable point A to the less excitable point B ; conversely, if the direction of the responsive current is from A to B, the point A may be taken as the more excitable. By means of the unfailing discrimination of the differences of excitability in a tissue which this method renders possible, it will be shown in the course of the present work that many of the anomalies of growth-curvature receive a most complete and satisfactory explanation.

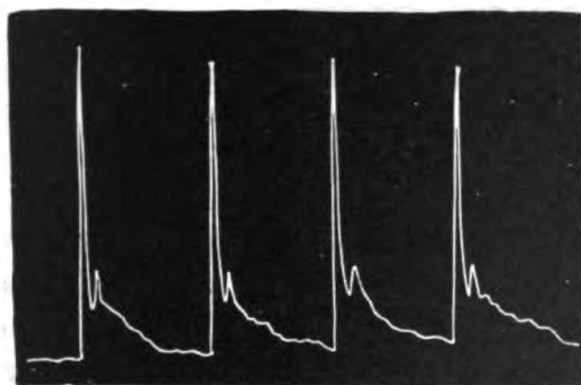

FIG. 28. Response of Selenium to the Stimulus of Light
(Conductivity variation method.)

The electrical response given by plant-tissues in general, as described in this chapter, is obtained by means of the difference of electrical potential or electromotive variation, induced as between the excited and unexcited portions of the tissue.

There is another method of detection by means of those changes of electrical conductivity which are concomitant to excitation in the substance under experiment.¹ It should be borne in mind that the various responses, obtained by the mechanical, by the electromotive, or by the conductivity-variation method, are merely different expressions of

¹ Bose, *Molecular Changes produced in Matter by Electric Waves*, Roy. Soc. Proc. 1 00.

that fundamental molecular change which underlies excitation, and which disappears on the restoration of molecular equilibrium.

Universality of responsiveness in matter.—If we take a plant-tissue and subject it to a sufficient degree of cold, its responsive power will be found to disappear. It reappears, however, on the return of the tissue to the normal temperature. The power of response is thus seen to depend on the molecular condition of the substance.

Now this irritability, or power of responding to stimulus, may be vaguely regarded as a characteristic property of

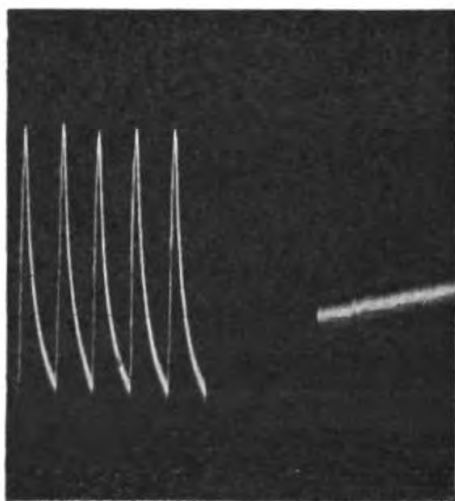

FIG. 29. Response of Metal abolished by the action of 'Poison' (Oxalic Acid)

The record to the left is the normal response, and the line to the right shows abolition of response on application.

living substances; and we may evade the difficulty of any attempt at a real explanation by describing it as a 'vital' phenomenon. But if we regard all such phenomena as due ultimately to physico-chemical actions, we cannot rest satisfied with what is, after all, a mere descriptive phrase. Progress can only be made in scientific inquiry by attempting gradually to discard all such assumptions of the working of mystical forces in favour of simpler and more rational explanations.

By following the electrical method of inquiry which has just been described, I have been able to prove that the power of responding to stimulus, and, under certain conditions, the arrest of this power, is the characteristic not of organic matter only, but of all matter, both organic and inorganic;¹ and that in general the various agencies which bring on the modifica-

¹ Bose, *Response in the Living and Non-Living*.

tion of response in one case—such as fatigue, temperature changes, stimulating or depressing chemical reagents—act in the same way in the other.

The capability of responding, so long regarded as the peculiar characteristic of the organic, is also found in the inorganic, and seems to depend in all cases, both qualitatively and quantitatively, on the condition of molecular mobility. In the course of the present work, then, the term 'physiological' is to be understood as a convenient expression for the phenomena of plant or animal tissues under investigation, and not as in any sense 'opposed to the word 'physical.'

SUMMARY

Stimulus causes molecular derangement in matter. The conditions of molecular upset and return to the state of equilibrium correspond to the state of excitation and recovery from that state.

The molecular disturbance is attended by various physico-chemical changes in the properties of the substance, among the most important of which in a living tissue may be mentioned (1) contraction of the excited cell, and expulsion of water; (2) electromotive variation; (3) conductivity-variation.

The true excitatory change causes negative variation of turgidity, with depression or negative mechanical response of the leaf, and galvanometric negativity. The intensity of these effects varies with the physiological condition, being totally abolished by those molecular changes which are concomitant with the death of the tissue.

By means of electrical response it is found that, not sensitive plants alone, but every plant and every organ of the plant is excitable.

Positive turgidity-variation, by whatever means produced, causes positive mechanical response—or, in the case of *Mimosa*, erection of the leaf—and galvanometric positivity.

A pulse of positive turgidity-variation is often propagated in consequence of the sudden expulsion of water from a stimulated point at a distance.

The laws of true electric response to excitation may be summarised as follows :

A. **The indirect effect of stimulation is a positive electrical variation, indicating a positive turgidity-variation.**

B. **The direct effect of stimulation causes negative turgidity-variation, concomitant with a negative electrical variation.**

- (1) **The direction of this responsive current in plant-tissues, as in animal, is from the more to the less excited portions of the tissue ; or, the excited point is galvanometrically negative.**
- (2) **On simultaneous excitation of two points, the current of response in the tissue is from the more to the less excitable.**
- (3) **Conversely, if the responsive current be from A to B, the point A may be taken as the more excitable.**

CHAPTER IV

ON CONDITIONS FAVOURABLE TO THE CONSPICUOUS EXHIBITION OF MECHANICAL RESPONSE

Differences of degree of motile sensibility in sensitive plants so called—Response of anisotropic organ brought about by differential contraction—Production of response by artificial variation of turgidity—Variation and counter-variation of turgescence, causing two opposite responsive movements—Differences between hydrostatic and true excitatory effects—Distinction of plants as ordinary and sensitive, arbitrary—Sensitive plants may be excited, yet give no mechanical response—Certain conditions necessary to exhibition of differential response—Balanced action as result of diffuse stimulus on radial organ—Slight differential contraction of pulvinus magnified by long petiolar index.

BY means of the electric mode of investigation detailed in the preceding chapter, I have shown that all vegetable organs, whether of ordinary or of sensitive plants, are excitable. Hence the supposed absence of motile indications, in ordinary plants, is not to be considered as due to want of sensitiveness, but to the lack of proper conditions for mechanical movement. What these conditions are will be described presently. But before entering upon such considerations, I first wish to demonstrate that even in the matter of the pulvinar motility itself there is no abrupt division, but a very gradual transition, from those plants in which it is scarcely perceptible, to others which exhibit it in a marked degree.

Range of sensitiveness in sensitive plants.—Three typical instances of plants possessing extremely sensitive, moderately sensitive, and almost insensitive leaflets, are: (1) *Mimosa pudica*, (2) *Biophytum sensitivum*, and (3) *Philanthus urinaria*. In *Philanthus* the small leaves borne on pulvini are arranged on two sides of the long twig or petiole, in a manner somewhat resembling the arrangement of leaflets in *Biophytum*. The plant appears on casual inspection to be

wholly insensitive, ordinary mechanical stimulation having no effect on its leaves. But if we apply strong thermal or electrical stimulus to the end of the twig bearing the leaves, then they begin to close very slowly, in serial succession. But whereas with *Biophytum* the response begins almost instantaneously, the maximum being reached in less than a second, and complete recovery attained in about four minutes, in the leaf of *Philanthus urinaria* the latent period, for moderate stimulus, is as long as three minutes, the maximum reached in not less than forty-five minutes, and complete

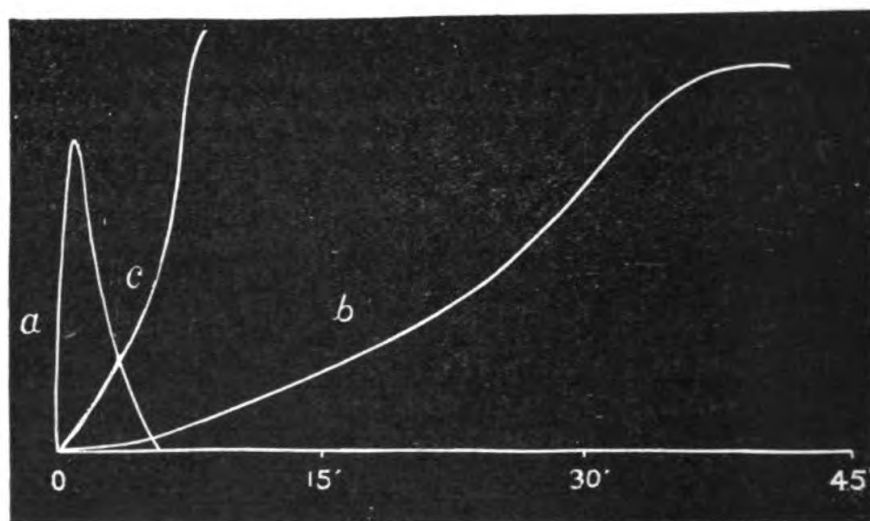

FIG. 30. Responses of (a) quickly reacting *Biophytum*, and (b) sluggish *Philanthus urinaria*, under moderate and (c) under stronger stimulation

recovery may require from two to three hours (fig. 30). It is seen, then, that even with regard to the so-called sensitive plants, there is a wide range of sensitiveness. In some, a slight shock produces quick reaction, in others a very intense stimulation is necessary to initiate response, and the reaction itself is very sluggish.

Anisotropy necessary to lateral response.—We shall now try to understand a little more of the mechanics which cause this responsive curvature. In these pulvinate organs, one thing that is noticeable is that the organ is not isotropic, that is to say, its properties are not the same in all directions.

The isotropic condition is seen in the case of radial organs, like cylindrical stems or peduncles. One way of showing this is to try to bend such a stem in all directions, when it will be found that equal forces produce equal bending in any direction. This, however, is not the case with dorsi-ventral organs, such as the pulvinus. This is more pliable in a vertical than in a lateral plane.

The mass of cells which constitute the lower half of the pulvinus, in *Mimosa* for example, is larger than that of the upper. The lower half is also the more excitable. The leaf remains in a balanced horizontal position, under the action of two opposing forces, the tensions of the opposite halves of the pulvinus, these tensions being modified by the turgidity of the cells. Pfeffer and Sachs have shown that under stimulation there is an expulsion of water from these excitable cells. This may be seen if we watch the cut end of a pulvinus very attentively after the disappearance of the excitation due to cut, and during the application of a new stimulus. The application of this stimulus is followed by a visible escape of water from the cut end. A more striking demonstration of this fact will be given in Chapter XXI.

Stimulus, then, induces diminution of the turgidity of the organ, by expulsion of water from the excited tissue, and I shall show by experiment how this negative variation of turgidity, owing to the dorsi-ventral inequality of the organ, causes the depression or fall of the leaf.

Response by artificial turgidity-variation.—We may fix air-tight the cut end of a branch of *Mimosa* bearing leaves in a U-tube filled with water. When this is done, a quantity of water is sucked up, and owing to this increase of turgidity the leaves will be forced to assume a highly erect or almost vertical position. After several hours this excessive turgidity will disappear, and the leaf will then assume a more or less horizontal position. The other end of the tube may now be connected alternately with a vacuum and with a force-pump, by means of which a diminution or increase of internal pressure may be induced at will. When connected with the

former, or vacuum-pump, water is sucked away, or expelled from the plant and its organs; when, on the contrary, the pressure is increased by connection with the force-pump, water is forced in. From the curve given below (fig. 31), it will be seen that the expulsion of water from the organ actually causes the fall of the leaf, and that the forcing of it back brings about erection. From the processes involved in this artificial response and recovery, we can see clearly how in the true response to stimulation we have a two-fold process of (1) the expulsion of water caused by stimulus, bringing about the depression of the leaf, and (2) the return

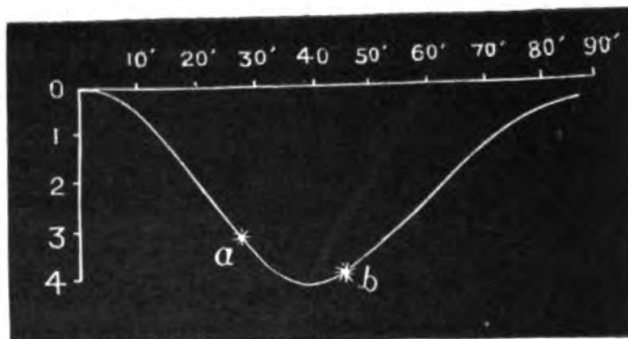

FIG. 31. Artificial Hydraulic Response of *Mimosa*

The plant was subjected to diminished pressure up to *a*, and to normal pressure to *b*, after which the pressure was increased. The effect of diminished pressure, in the depression of the leaf, continues for a while. The ordinate represents movement of tip of leaf in cm., abscissa represents time.

of water into the organ, bringing about the restoration of the leaf to its original position, or recovery. And since the lower half of the organ is the more contractile, it is evident that in this lower half there must be relatively greater expulsion and absorption during response and recovery.¹

Two possible types of response.—We must bear in mind that the entire response consists of these two alternating processes, and that the recovery, or restoration of turgidity,

¹ As a normal type I have taken the pulvinus of *Mimosa*, the excitability of the lower half of which is greater, and where the responsive movement is down. But there may be other cases. If the excitability of the upper half be relatively the greater, excitation will in such cases cause upward responsive movement. In what follows, unless the contrary be stated, I shall speak of the normal type.

is not a passive but an active process ; for when the tissue is killed it remains flaccid. Throughout the phenomenon of response, the essential factor is the variation of turgidity from, and its return to, the normal. This variation, as generally seen, consists of a fall below, and recovery to, the original level of turgescence. And this, as we have seen, is accompanied by the sequence of the fall and rise of the leaf. But theoretically it should be quite possible to bring about a responsive movement by means of the counter-variation, namely, an increase, followed by diminution of turgescence. In such a case the concomitant movement would be a rise and fall, instead of the opposite. Something of this kind will be observed in studying the daily periodic movements of the *Mimosa* leaf, where the rise and fall of the leaf will be found to synchronise with alternating increase and diminution of hydrostatic pressure.

Abnormal hydrostatic and true excitatory effects.— Certain effects due to the variation of turgor above and back to the normal, will be seen in growth-responses, to be treated later. For the present we may find an instance in the abnormal erectile twitch, which has already been noted, in certain responses of *Biophytum* (fig. 17). In that case, as was explained, the pulse of increased pressure, due to the expulsion of water from the distant stimulated point, was the first to reach the motile organ, causing erection. The true excitatory effect reached the same organ later, with the normal effect of depression. The abnormal erectile effect may be produced artificially, say by sudden forcing in of water. But, in the case mentioned, the pulse of increased pressure which brought about this effect was due to stimulation of a distant point. I shall henceforth, as stated before, distinguish the two effects as (*a*) the direct and (*b*) the indirect effects of stimulation. When a tissue is directly stimulated, there is produced a negative turgidity-variation ; normal negative mechanical response, or fall of the motile leaf ; and normal electric response of galvanometric negativity. The velocity of transmission of this excitation is

relatively slow, and, as has been said, definite, and characteristic of the plant under normal conditions. This velocity varies, as will be seen later, in the case of different plants, from a rate of about .5 to about 15 mm. per second. And this true excitatory response, mechanical or electrical, undergoes appropriate modifications, according to the physiological changes of the tissues, and is abolished at death.

The hydrostatic effect, on the other hand, may be seen, in the form of a preliminary twitch, when the specimen is indirectly stimulated—that is to say, when the stimulus is applied at a distance from the point where the responsive effect is observed. The hydrostatic effect gives rise to positive turgidity-variation ; abnormal positive or ' up ' mechanical response ; and abnormal galvanometric positivity. The velocity of transmission of this hydrostatic disturbance is relatively very great, being about several hundreds of mm. per second.

The conditions of exhibition of excitation by lateral response.—We shall next consider the question of that division of plants into sensitive and ordinary which has led to the impression that only the former are excitable. And, first, we shall study the conditions which are favourable to the exhibition of the motile effect, according to which it is customary to estimate the sensitiveness of the plant. We have seen that in plants like *Mimosa* it is the difference in excitability between the two halves of the motile organ which makes it possible for it to exhibit the state of excitation by means of lateral movement. If, then, through any circumstance, this difference of excitability as between the two halves of the organ be diminished or abolished, a plant which is undoubtedly sensitive will appear insensitive, as judged by the mechanical test. The *reductio ad absurdum* is reached when the same plant is sensitive and insensitive at the same time.

As an instance of this, we may take the plant *Biophytum*. In consequence of age, the differential excitability of the pulvini of the leaflets disappears. Hence, when an old leaf is excited, its leaflets give no motile indication, and we are

apt to consider it as insensitive. But on applying the test of electrical response, we discover that, though there is no mechanical indication, excitation is nevertheless present. Again, if the stimulus be sufficiently strong, the wave of excitation will pass through the old leaf, without producing any visible effect, and on reaching the younger will be manifested by the conspicuous motile response of their leaflets.

Again, we have seen that one of the conditions for the production of the responsive movement was the expulsion of water from the excited tissue. Hence, if this expulsion of water be in any way impeded, mechanical response may not take place. This may be seen in the following experiment: The cut end of a *Mimosa* stem is placed in water. A large amount of water is now found to be absorbed, and an abnormal turgidity is produced in the tissue, in consequence of which the leaves are erected almost vertically. If stimulus be now applied, there is no responsive movement owing to the difficulty of the expulsion of water from the gorged tissue. But the specimen is found to exhibit its state of excitation by electrical response, thus proving that not its sensitiveness, but its power of manifesting it mechanically, has been arrested.

We must bear in mind that, in these cases of differential response, the efficiency of the motile apparatus depends upon a delicacy of poise as between the two halves of the organ, which is capable of being easily upset, under the action of stimulus. This poise is determined by the antagonistic tissue-tensions of the two halves, and this again must be modified by the distribution of water, or the relative turgor-variations, in the two halves. Any deviation from the normal distribution of turgidity might, therefore, be expected to affect the exhibition of the motile effect. Thus, early in the morning, owing to excess of turgor-tension, the leaflets of *Biophytum* show hardly any response, and their motility disappears altogether, when the turgor is raised still higher, on wet days. But later in the day, when

E

the periodic turgor-tension characteristic of the morning has passed off, the plant exhibits normal mechanical responses. We have again seen that when the plant *Mimosa* is placed for a time in a dark room, and an abnormal condition of turgor—as seen in the erection of its leaves—is induced, the strongest blow will often produce no mechanical response.

It is thus clear that the fulfilment of certain conditions is necessary, in order that a plant may exhibit its state of excitation, by mechanical response. The absence of this response is therefore no proof of the insensitiveness of the plant. Having thus shown that sensitive plants so called may under certain conditions fail to give motile indications, we shall in the next chapter see whether, on the other hand, ordinary plants—commonly assumed to be insensitive—may not be found to exhibit mechanical response to excitation; such mechanical response having been hitherto overlooked, either in consequence of our own imperfect observation, or from the fact that in radial organs excitatory reactions would be likely to have a multi-radial character, which would cause them to balance each other.

Explanation of absence of lateral response in radial organs.—Taking first, then, the case of a radial stem, that is to say, one whose properties are the same in all directions, we shall find that a single stimulus applied simultaneously on all sides—in other words, a diffuse stimulus—would, even if it produced responsive contraction, result in no visible lateral movement like that seen in *Mimosa* leaf. This would be due to the fact that the contractions at various diametrically opposite points would be antagonistic, and balance each other. Though lateral movement would thus not take place in a radial organ, yet it is possible under favourable circumstances, as will be shown in the next chapter, to obtain longitudinal contraction as seen in muscle. Lateral movement in response to a diffuse stimulus can therefore take place only when there is some difference of excitability as between two opposite halves of an organ. The movement will then be

brought about by the greater contraction and resultant concavity of the more excitable.

Differential contraction effect in *Mimosa* magnified by the petiolar index.—We are impressed with the magnitude of the responsive movement of the *Mimosa* leaf. It is worth while to remember, however, that the fundamental differential contraction of the organ by which this is brought about is very inconspicuous. If the petiole be amputated, we shall hardly notice the responsive action of the pulvinus. But the petiole, with its attached secondary petioles, acts as a long index, by which the curvature produced at the pulvinus on excitation is highly magnified. Many plant-movements, which now pass unnoticed, would have arrested our attention had there been in their case any such magnifying index.

SUMMARY

An anisotropic organ is unequally excitable on its two differentiated sides.

In a dorsi-ventral organ, like the pulvinus of *Mimosa*, lateral response is brought about by the differential contraction of the two halves.

In such dorsi-ventral organs, owing to the differentiation of the two halves, an increase of turgidity causes erection, and a diminution the depression, of the leaf.

Hence two opposite kinds of responses are possible, (*a*) that which is usually seen, due to the negative variation of turgidity, followed by recovery to the normal ; and (*b*) the counter-variation, that is to say, a variation of turgidity above the normal—causing abnormal erectile response—and recovery.

The ordinary mechanical response of dorsi-ventral organs being dependent on (*a*) the difference in excitability of the two halves, and (*b*) on the expulsion of water from the excited organ, it follows that any condition which diminishes or abolishes this difference, or prevents the expulsion of water, will render the mechanical response impossible. A

plant may thus be sensitive, and yet fail to exhibit mechanical response. Hence the absence of mechanical response is no indication of the plant's insensibility.

In a radial organ under diffuse stimulation there can be no lateral response, owing to the balanced and mutually antagonistic character of the contractions produced.

The excitatory differential contraction in *Mimosa* would be inconspicuous but for the magnification produced by the long petiolar index.

CHAPTER V

MECHANICAL RESPONSE IN ORDINARY LEAVES

Pulvinoid and pulvinus -Demonstration of mechanical response in ordinary leaves—Response of *Artocarpus* similar to that of *Biophytum*—Response to stimulus, even in old tissues, by expulsion of water—Localisation of motile organ in ordinary leaves—Conducting properties of various tissues—Lamina is not the perceptive organ—Response in ordinary leaves, though sluggish, yet comparable in extent to that of *Mimosa*—Peculiar phenomenon of fatigue-reversal seen in *Mimosa* observed also in ordinary plants—Periodic reversals.

WE have seen, in the course of the last chapter, that even a sensitive plant will fail, under certain conditions, to give any mechanical indication of its state of excitation. We shall now proceed to determine whether, on the other hand, motile response may not be detected in the case of ordinary plants.

It has already been said that the popular division of plants into sensitive and ordinary is purely arbitrary. It is the erroneous impression consequent on the use of these terms which is responsible for the fact that inquirers have accepted without hesitation the assumption on which the classification rests. Had such not been the case, it must long ago have been discovered that the leaves of even ordinary plants respond to stimulus by mechanical movements, in precisely the same manner as do those of sensitive plants.

We have seen that the condition necessary for the production of lateral responsive movement is, that the organ be anisotropic ; that is to say, there must be a differentiation as between the upper and lower halves. The petioles of

ordinary leaves are obviously anisotropic, their upper and lower halves being quite unlike. We might, therefore, expect to find in them the exhibition of differential response. There is, however, some difficulty in detecting these responsive movements of ordinary leaves in an unmistakable manner, inasmuch as flexibility is not so great in ordinary petioles as in those which are provided with a pulvinus. Moderate stimulus therefore causes in these relatively smaller movements, and unless some form of stimulation can be used which brings about no mechanical disturbance of the plant itself, it is impossible to discriminate the true responsive movement. I have, however, described modes of stimulation, by the electro-thermic stimulator and by electric shocks, by means of which this difficulty is overcome. By the use of the Optic Lever, further, a magnified record of the responsive movement and its time-relations may be obtained.

Pulvini proper and pulvinoids.—We have seen that the responsive effect is caused by the turgidity-variation due to stimulus. Such motile indications can occur with facility only in tissues which are not yet hardened. We may therefore expect to find motile effects throughout the anisotropic petiole and its prolongations, especially in young leaves. After a certain time, in many instances, it is only portions of the petiole, such as those at the junctions of the petiole with the stem and lamina, that remain flexible. These flexible points are sometimes rather swollen or cushion-like, and may be seen—though in a much less developed condition than in *Mimosa*—in the leaves of many ordinary plants. But such areas, in ordinary leaves, are usually regarded as non-motile, and therefore functionally distinct from the true pulvini in sensitive plants. I shall therefore, for the sake of convenience, distinguish between *pulvini* proper and these *pulvinoids*. But I shall show presently that, contrary to the usual belief, these pulvinoids also are fully sensitive. Functionally, then, we have in young leaves a diffuse pulvinoid, which is capable of mechanical motility, throughout the length of the petiole.

Later, we find the pulvinoid localised at one or two points only, such as the stem and laminal junctions, the motile function persisting here for some considerable period. And finally, in the markedly motile pulvini of the so-called 'sensitive' plants, we have the property of motility manifested throughout a still greater length of time. It will thus be seen that we can scarcely draw any sharp line of demarcation between *pulvini* proper and the *pulvinoids* of ordinary plants. And when the leaves are old, both alike cease to be motile.

Mechanical response of *Artocarpus*.—I shall now describe the method by which I have obtained records of these mechanical responses in ordinary leaves. For this purpose I took a pot-grown specimen of *Artocarpus integrifolia*, or Jack-fruit plant, the leaves of which are stiff and, as far as the eye can judge, singularly inappropriate for the exhibition of motile effects, and selected for my investigation the third leaf from the top of a stem, this being neither too young nor too old. I have said that in an anisotropic petiole the response ought to take place by the induced concavity of the more excitable half, whether upper or lower. In this case it was impossible to know from inspection which was the more excitable. But I have described, in the last chapter, an electrical method by which differences of excitability, arising from molecular or anatomical differentiation, can be distinguished. It was there explained that the electrical current of response flows from the relatively more to the relatively less excitable. And on repeating the electric experiment, in the present case, I found the responsive current to flow from below upwards. This proved that in *Artocarpus* the lower surface of the petiole was, as in the case of *Mimosa*, the more excitable of the two. Hence, if we should obtain the mechanical response from this apparently non-sensitive leaf, we might expect that it would be downwards. In order to produce stimulation, I used the electro-thermic stimulator, in the manner already described. The stimulus was first applied at a point on the petiole 3 mm. from the laminal

junction. From the record given below (fig. 32), it will be seen that the responses are similar, even in minute details, to those obtained with sensitive *Biophytum* leaflets.

It will be seen that we have first the abnormal erectile twitch, due to transmitted hydrostatic disturbance, which takes place almost instantaneously. The true responsive effect is found to follow, after an interval of four seconds. From this we obtain the velocity of transmission as .75 mm.

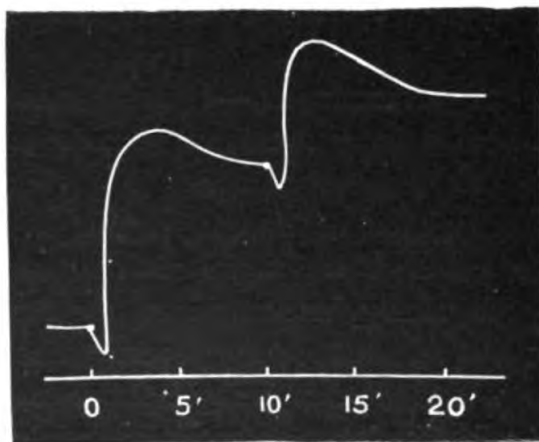

FIG. 32. Response of Ordinary Leaf (*Artocarpus*)
Note preliminary erectile twitch.

per second, that is to say, about one-third the rate found in *Biophytum*. A somewhat incomplete recovery took place in the course of ten minutes. The successive responses are found to be nearly uniform; but if only shorter intervening periods of rest be allowed, they exhibit marked fatigue. That the motile region is somewhere near the junction of the lamina with the petiole, was proved by the fact that on bringing the stimulator nearer to, or further away from, this point, the responses underwent corresponding increase or diminution.

I obtained similar responses by subjecting the lower pulvinoid, that, namely, at the junction of the petiole with the stem, to similar stimulus, which was now applied on the adjacent stem. In the preceding experiment the Optic Lever was attached to the lamina, but in this case, in order to avoid possible complications from the responses of two pulvinoids in succession, I tied a thin stiff wire to the intervening portion of the petiole, and the Optic Lever was attached to this wire, instead of to the lamina. By this means the response of the lower pulvinoid alone was recorded.

per second, that is to say, about one-third the rate found in *Biophytum*. A somewhat incomplete recovery took place in the course of ten minutes. The successive responses are found to be nearly uniform; but if only shorter intervening periods of rest be allowed, they exhibit marked fatigue. That the motile region is

Excitatory reaction in older tissues.—One very important and hitherto undecided question, which is answered by this experiment, is as to whether all tissues, even the old, give contractile response by expulsion of water, or by negative turgidity-variation. In the pulvinus such an effect is made evident by the differential contractile movement produced. In young tissues it will be shown that we have effects exactly similar. But in older tissues no such movement is observable. Of this fact, two alternative explanations are possible: (1) there may be no excitatory expulsion of water in old tissue; (2) such expulsion may occur, while movement is at the same time rendered impossible, by the inflexible condition of the tissue. We have already seen how, whenever there is negative turgidity-variation due to excitation, there is also a simultaneous galvanometric negativity. Conversely, induced galvanometric negativity may be taken as an indication of the excitatory expulsion of water. And from this indication the conclusion is arrived at that, even in relatively old tissues, this excitatory expulsion occurs, since these tissues on excitation exhibit galvanometric negativity.

I was desirous, however, to obtain additional proof of this excitatory expulsion of water in the older tissues, and from the preliminary positive twitch seen in the mechanical response (fig. 32) the existence of such action is clearly proved. For the preliminary erectile twitch observed in the leaf, when the rigid part of the petiole—or of the stem at a distance beyond the petiolar junction—is excited, can only be explained by a pulse of increased pressure towards the motile area, initiated by water expelled from the stimulated point. Independent experiments, carried out by other methods, also tend to show that, though the power of excitatory contraction undergoes diminution with age, it does not, generally speaking, disappear entirely.

We saw in *Biophytum* that when stimulus was applied at a distance, the hydrostatic disturbance produced the preliminary erectile twitch. But no such effect was observed

when the pulvinus was directly stimulated, the result now being the true excitatory fall alone. In the case of *Artocarpus* I obtained the same result. Direct stimulation was here applied, at the motile region, by electric induction shocks, the electrical connections being made on two sides of the pulvinoid, by means of thin flexible spirals of tinsel which did not offer any obstruction to the free movement of the responding leaf. The response thus obtained was normal, and unattended by any preliminary positive twitch.

The motile responsiveness of *Artocarpus*, then, is seen to follow that of *Biophytum* or *Mimosa*, even in details. An instance of this is found in the fact that in all three cases abnormal increase of turgidity is unfavourable to the manifestation of mechanical response. Thus, just after the rainy season, the *Artocarpus* is highly turgid, and response not easily obtainable. But in November, when the turgor has become moderate, its motile indications are once more made conspicuous.

If the motile region be extended, or diffuse, the responsive action when the stimulus is applied at any single point becomes very complicated. For we have, first, the preliminary hydrostatic pulse, travelling along the whole length of the motile organ, and producing a somewhat long-continued erectile effect, which is, therefore, unlike the quickly exhausted erectile twitch that took place during the short passage of the hydrostatic pulse through the restricted pulvinoid. And, secondly, follows, in the wake of this, a wave of negative turgidity-variation concomitant to the passage of true excitation. Such complicated effects may be avoided, however, by applying electrical stimulus simultaneously throughout the whole area. The electrical form of stimulation has therefore certain advantages, but it is apt to bring on quick fatigue of the tissue.

Localisation of motile areas.—I shall now deal with some further difficult points, in connection with the motile response of the leaf. And first comes the question of localising

the motile area itself. Next comes that of the possibility of excitation reaching the motile organ from a distance, through certain specific tissues, and the determination of the nature of such tissues. By using the experimental methods which I have described, it is possible to determine these important points. But, before doing this, it will be well to enter upon the theoretical considerations in connection with the subject.

As regards the first point, it has been shown that any flexible anisotropic organ is capable of lateral response owing to differential action. In the leaf, when young, the power of movement extends throughout the length of the petiole and its prolongation, the midrib. But when older, as has been said, the motile power becomes localised at the pulvinoids or pulvini. This conclusion is verified by experiment. The young petiole is found motile throughout its length, but when older the existence of certain specialised areas is made evident by the fact of the strong response obtained, when stimulus is applied on such areas, and its rapid diminution on application at gradually increasing distances. For example, in the case of *Artocarpus* leaf, when this distance from the pulvinoid is increased to 1 cm. the normal response to moderate stimulus disappears altogether. In this connection it is well to bear in mind the fact, which will be fully demonstrated later, that the distance to which the effect of stimulus is transmitted depends not only on the conductivity of the tissue, but also on the intensity of the stimulus. A moderate intensity of stimulus is only effective in producing motile indications when the application is on, or very near, the pulvinoid. We thus see, as regards motile organs, that there is a strict continuity between those cases in which the property of motility is diffused through a large area, and others in which it is contracted to one or more definite points, this last form culminating in the maximum flexibility of pulvini proper.

The petiole of the leaf of *Biophytum* itself gives an excellent example of a diffuse pulvinoid. It is not provided with any specialised pulvinus, such as that of *Mimosa*, or of its own

leaflets. But if this petiole be subjected to any form of stimulus, it responds by a depression of the leaf as a whole. On the cessation of stimulus there is the usual recovery. In a subsequent chapter I shall describe in detail the responses of the petiole of *Biophytum* to different forms of stimulation.

Conducting properties of various tissues.—With regard to the next point, this is to say, the transmission of excitation to a distance, it will be shown in Chapter XX. that the transmission of the excitatory state is brought about by the propagation of protoplasmic changes from point to point. We may therefore expect that tissues in which there is more or less uninterrupted protoplasmic continuity will be those which will, other things being equal, show the greatest power of transmitting stimulus. Even in such cases it will be understood that the transmission becomes enfeebled with distance. Now the tissues in which this continuity is most uninterrupted are the fibro-vascular elements. Hence, stimulus applied on the petiole, or its prolongation, will reach the motile organ, with the greater intensity, the nearer the point of application is to the motile region. We should expect, on the other hand, that indifferent tissues, like leaf parenchyma proper, would prove to be, owing to the more or less complete cellular partitions, incapable of transmitting stimulus to a distance. These considerations I have been able to verify experimentally by means of electric response. I shall here, however, describe experiments in which the same conclusions are established by the method of mechanical response.

Moderately strong electrical stimulus from an induction coil was applied on the petiole of *Artocarpus* at points increasingly far from the laminal pulvinoid; these produced motile responses which diminished rapidly with distance, as was described in the last experiment. But when such stimulus was applied on the lamina, at a point relatively near the pulvinoid, there was no response. This shows that the lamina is not to any extent the perceptive organ, and that stimulus received on such an area does not cause movement of the leaf as a whole.

It will thus be seen that the petiole when young is both the motile and the transmitting organ. With increasing age, certain areas become inflexible, and the power of motility is narrowed to the still remaining points of flexibility—the pulvinoids. But the inflexible petiolar portion still retains the power of transmitting stimulus. Using the language of Animal Physiology, we might say, therefore, that a young petiole is, functionally, nerve and muscle combined. Later there is a differentiation into motile pulvinoids, corresponding to muscle, and the rest corresponding to conducting nerve. The pulvinoid, however, has still the power of transmitting stimulus.

To serve the purpose of a concrete example, I have taken as a typical case the *Artocarpus* leaf. I shall now, however, show that responsive motile effects are obtainable from the leaves of plants in general. In the record given (fig. 32) I applied only moderate stimulus, in order that the magnified response might be brought within the limited space of record. From this, it might be supposed that the extent of responsive movement in ordinary leaves is relatively much smaller than what is obtained with the sensitive *Mimosa*. But this is by no means the case. By using stronger stimulus a response is obtained, in the case of many ordinary leaves, which in its extent is strictly comparable with that of *Mimosa*. Of this, I shall here proceed to give examples. But, before doing so, we must remind ourselves that the promptitude of mechanical response is a matter of the delicacy of poise of the motile apparatus. In the case of *Philanthus*, which is provided with distinct pulvini, we found that response took place very sluggishly, and was evoked only by relatively strong stimulus. The difference between the response in this case and in that of *Mimosa* is, however, not of kind, but of degree.

Response of ordinary leaves comparable with that of *Mimosa*.—When we come to the response of ordinary leaves, we find, under strong stimulation, considerable extents of movement, even rivalling those of *Mimosa*, but taking place

with a comparative sluggishness which, generally speaking, is not so great as that of *Philanthus*. In the following experiments various leaves were excited by strong electric shocks, sent through the entire length of the petiole, and responsive movements were, as a rule, observed, the leaves in these instances falling downwards from their normal more or less horizontal position. Of these I shall give only three instances. A particular leaf of *Bryophyllum calycinum*, which is unprovided with a pulvinoid, was 5 cm. in length. After tetanic shocks of three minutes, the leaf fell, the distance traversed by the tip being 2.1 cm. A leaf of *Canna indica*, again, unprovided with any pulvinoid and not too young, was 20 cm. in length. On the application of tetanic shocks for one minute, the leaf fell, the distance traversed by the tip being as much as 14 cm. The third instance is a leaf of *Ficus religiosa*, 14 cm. in length. After three minutes of continuous stimulation, the leaf fell, the tip passing through a distance of 12 cm. It will thus be seen that the movement caused by stimulation in ordinary leaves is quite considerable.

It may, however, be objected that the fall of the leaf is really due simply to its weight, acting on the petiole when rendered flaccid. Even in this case the flaccidity would be directly due to stimulation, and the movement of the *Mimosa* leaf itself must be regarded as being of a similar nature. But in order to prove that the movement of the leaf is mainly due to the active differential contraction of the upper and lower halves, and in order to eliminate completely the effect of weight, I arranged the experiments as follows: The plant was held with the leaf directed vertically downwards. The movement due to the greater contraction of the lower half of the organ, in consequence of the true excitatory effect, ought now to raise the leaf against the force of gravity. And this, as will be seen from the records (fig. 33), was found to be the case.

In order to compare the angular movements of some ordinary leaves, and their time-relations, with those of *Mimosa*, when subjected to strong electric shocks, I took

records of such movements in these different cases on the same revolving drum. And with the purpose of making the angular movements, in the various instances of long and short leaves, comparable, I rendered the virtual length the same in all cases, by attaching longer or shorter indicators, as was necessary, and the movement of the tip of the indicator or its projection was then recorded on the drum. The longest leaf experimented on in this series was *Mimosa*, having a length of 5 cm. In this case no additional indicator was attached; and in other cases the indicator-lengths which were added made each leaf have a virtual length of 5 cm.

Fatigue-reversals in ordinary leaves, as in *Mimosa*.—

In comparing the response-records of various specimens, it is necessary to understand one peculiarity which is observed in certain responses under long-continued stimulation. In order to do this, I must anticipate a certain characteristic of *Mimosa* response, which will be more fully described in Chapter IX. It is found that the leaf of *Mimosa* gives immediate response to stimulus, by a fall or contraction of the lower half. But when the stimulus is long continued, the leaf rises gradually to its original position, or even, sometimes, beyond this. This position is, however, only apparently normal, being really a posture of fatigue. For whereas, while the leaf is fresh, it responds to stimulus by depression, it is now, though it occupies the same position, entirely insusceptible of excitatory depression. In exhibiting the effect of long-continued stimulation on ordinary leaves, I shall be able to show that they resemble *Mimosa*, not only in the extent of their responses, but also, in certain cases, even with regard to this specific characteristic.

In the records given (fig. 33) the first curve is of *Mimosa* leaf. It should be remembered that the experiments in all these cases were carried out with the leaves held perpendicularly downwards, the excitatory movement being produced by strong and continuous tetanic shocks. The excitatory effect recorded, therefore, is due to the differential contraction of the two halves of the motile organ, lifting the leaf against

gravity. In the specimen of *Mimosa* (*a*) the maximum responsive deviation of 25° was reached in a little more than one second, after which occurred the peculiar reversal already referred to. This, which was due to fatigue, was completed in seven and a half seconds. The next curve (*b*) was obtained from the young leaf of *Citrus decumana*. It will be observed that here we have a practical duplication of the curve of *Mimosa*, the only difference lying in the longer period necessary for the completion of its different parts. The responsive deviation in this case is 30° , that is to

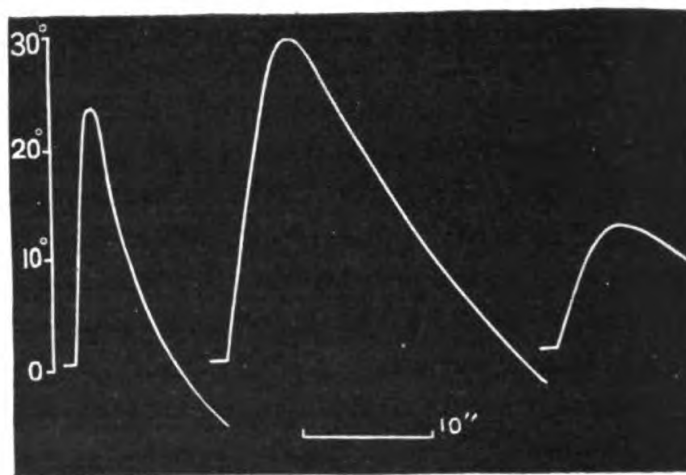

FIG. 33. Response of Leaves of Ordinary Plants to Electric Stimulation
The ordinate represents the angular movement in degrees.

say, even greater than that of *Mimosa*. This was attained in eleven seconds, and reversal completed in twenty five seconds. The extent of these responsive movements, being due to differences of excitability as between the two halves, will, it is easy to understand, be modified by the age of the leaf. This fact is illustrated by the next curve (*c*), obtained with an older leaf of the same plant. Here the responsive movement takes place through only 10° , and there is only a partial reversal.

The instances given may be considered as typical, the responses obtained with specimens of other plants being simply variations of these. For example, while some leaves

under continuous stimulation exhibit complete, and some partial, reversals, there are again other species of plants whose leaves do not exhibit any reversal at all. Still others, again, exhibit periodic reversals. The effects produced are thus seen to depend on the species of the plant, on the age of the leaf, and on the intensity and duration of the stimulus.

It will thus be seen that an anisotropic organ like the petiole responds to stimulus by differential contraction of its upper and lower halves, and that the mechanics of such movements in the case of ordinary leaves are precisely the same as in those of the leaves of sensitive plants such as *Mimosa*. In the next chapter I hope to show that even radial organs are not insensitive, but exhibit responsive contractile movements.

SUMMARY

The motile organs of ordinary leaves, owing to dorso-ventral differentiation, give mechanical response by differential contraction, in a manner precisely the same as does the motile organ of *Mimosa*.

In a young leaf, the petiole and its prolongation act as a diffuse pulvinoid; later, the motile area becomes restricted to certain points, generally speaking, the junctions of petiole and stem, and petiole and lamina. There is no sharp line of demarcation between *pulvinoids* and *pulvini* proper.

Even in relatively old and rigid tissues, response to stimulus is by excitatory expulsion of water.

Responsive movements take place in ordinary leaves, when the stimulus is applied at or near the motile organ.

The lamina is not, generally speaking, the perceptive organ. The effect of stimulus remains in this case localised, and is not transmitted to a distance.

Organs like the petiole, which contain fibro-vascular elements, are capable of conducting stimulus to a distance.

Under continuous stimulation there may be reversal due to fatigue in ordinary leaves as in *Mimosa*. In some cases, periodic reversals are also observed.

F

.

CHAPTER VI

LONGITUDINAL RESPONSE OF RADIAL ORGANS

Absence of lateral response movements in radial organs due to mutually antagonistic effects of equal contractions of diametrically opposite sides—Lateral response in radial stem of Walnut under unilateral stimulation—Also in pistil of *Musa*—Diffuse stimulation of radial organ causes longitudinal contraction—The 'Kunchangraph'—Longitudinal contraction of stamens of *Cynereæ* not unique—Similar longitudinal responses obtained with stems, roots, tendrils, petioles, stamens, and styles of ordinary plants—Also in fungi—Responsive contraction in *Passiflora*, comparable in extent with that in *Cynereæ*—Longitudinal response in plants modified by the physiological variations due to age, season, and chemical agencies.

WE have now considered the phenomenon of responsive lateral curvature in plant-organs such as leaves, and have seen that it is brought about by the differential contraction of two unequally excited halves. But in the case of radial organs, under diffuse stimulus, such responsive movements are not usually noticeable, hence these organs have generally been regarded as insensitive.

It is, however, conceivable, as already said, that this absence of responsive movement might be due to the occurrence of simultaneous contractions in diametrically opposite sides, which would balance each other, and thus permit of no lateral movement. The correctness of this supposition might be tested in either of two ways. We might, for instance, apply a unilateral instead of a diffuse stimulus, and so bring about a lateral contraction. Or we might use a diffuse stimulus, and look for the contraction in length of the specimen as a whole.

Experiments showing equal and opposite reactions of radial organs.—If we apply local and unilateral stimulus,

we may expect contraction of the acted side alone. The stimulated side should thus become concave. I have been able to verify this by experimenting with, amongst others, the radial stem of a young Walnut plant ; stimulus was applied in a region about 4 cm. from the tip, this being a plastic area, just below the zone of growth. There are practical difficulties in the application of unilateral stimulus, which might easily be overcome by the use of photic stimulus. In the present chapter, however, I intend to deal with forms of stimulation other than that of light. In the experiment on Walnut, therefore, I made use of the stimulus of electric shocks from an induction coil. The electrical connections were made with one side only of the radial stem. Small quantities of kaolin paste, moistened with normal saline solution, were placed on the stem at two points, at a distance of 2 cm. one above the other, and these were connected with the terminals of the induction coil by means of flexible spirals of tinsel. Electrical excitation was now produced by tetanising shocks for the requisite length of time. With regard to this, it must be pointed out that excitation given by such means cannot be strictly confined to one side of the organ alone, since the current will pass through the further side also ; but as most of it will take the shortest path, excitation will be relatively greater on the side of the electric connections. The responses were recorded as usual, by attaching the stem to the Optic Lever.

Strong electrical shocks being now applied during a period of five seconds on one side of the stem, a responsive concavity of that side was produced, the amplitude of the response being eight divisions. The effect attained its maximum in forty seconds, after which the recovery was partially completed, in six minutes. On now exciting the opposite side of the same stem, a response which was practically the same—*i.e.* 7.5 divisions—was obtained, the curvature being now in the opposite direction. Hence it is clear from these two experiments, that when a radial organ is simultaneously excited on all sides, there can be no lateral

curvature, owing to the fact that opposite reactions neutralise each other.

I succeeded in obtaining a singularly perfect demonstration of the response of a radial organ to local and unilateral stimulation, by paying special attention to the selection of the specimen and mode of stimulation. I took a pistil of *Musa paradisiaca*, in which I was able to localise with great distinctness the zone of growth, in this particular case of not greater extent than 2 mm. The stimulation, which was thermal, was effected by placing on one side of the selected area, but not in actual contact with

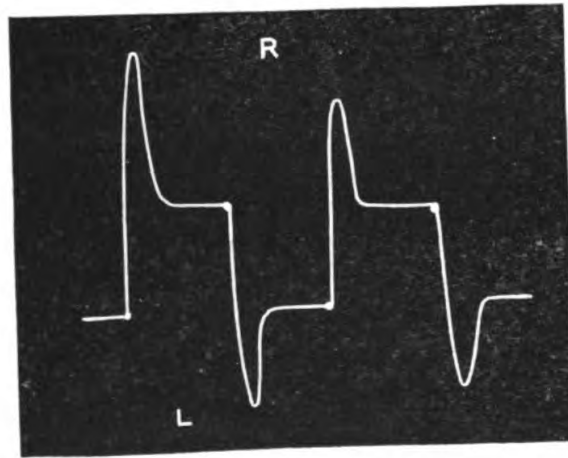

FIG. 34. Alternate opposite-directioned Responses obtained by the successive Unilateral Stimulations of opposite sides of Pistil of *Musa*

R, responses of right side, upwards; L, responses of left side, downwards.

it, the outer point of a small V-shaped piece of platinum wire which could be put in circuit with a battery. An exactly similar arrangement was made on the other side of the organ, at the diametrically opposite point. By sending a heating current from the battery through either of the platinum pieces for a definite length of time, the tissue in that region is stimulated locally by thermal radiation. In this manner two opposite points of the tissue may be alternately subjected to equal stimulation. The accompanying figure (fig. 34) gives the record of such an experiment. The up-responses here represent the concavity produced by stimulating on one side, say the right, and the down-responses the same on the left. It will thus be seen that equal and opposite responses were obtained, equal alternate stimulation of the two sides. The recovery, it will be noticed, is not complete, the curvature caused by

it, the outer point of a small V-shaped piece of platinum wire which could be put in circuit with a battery. An exactly similar arrangement was made on the other side of the organ, at the diametrically opposite point. By sending a heating current from the battery through either of the platinum pieces for a definite length of time,

stimulus being partially fixed by growth. The responses, moreover, afford some slight indication of fatigue.

But though there is thus no lateral movement, owing to the antagonistic character of the simultaneous longitudinal contractions on all sides, we might nevertheless hope to detect some responsive contraction in the length of the organ as a whole. And perhaps it will be well to consider at this point what would be the most favourable condition for the exhibition of such contraction. Taking the parallel instance of contractile animal tissue, namely muscle, we can easily see that if this were attached throughout its length to a rigid structure such as bone, contractile movement would have been an impossibility. Similarly, contractile vegetable tissues when attached to hard elements, such as wood, must be prevented from exhibiting contractile movements. The vegetable tissues, therefore, which ought to be best fitted to exhibit this effect, will be comparatively deficient in hardened fibro-vascular elements, and will consist largely of prosenchymatous cells, relatively longer in one direction, and very elastic and highly extended by turgidity. The diminution of this turgidity by stimulus might then be expected to produce a relatively large degree of longitudinal contraction.¹

Excitatory contractions in *Cynereæ*.—This shortening in length is most strikingly exhibited by the filaments of the stamens of *Cynereæ*. This subject has been specially studied by Pfeffer, and the account which I give here is epitomised from Sachs' 'Physiology of Plants.'² The filaments of the stamens of *Centaurea jacea* are free from each other, but the anthers cohere, forming a tube. The stamens are, in the unexcited state, strongly curved convexly outwards. If now the filaments are all excited simultaneously, say by mechanical touch, there is produced a downward withdrawal of the

¹ I have shown that galvanometric negativity is an unmistakable indication of the excitatory contraction of a vegetable tissue. Employing this test, I find that all living vegetable tissues are excitable. But the mechanical contraction produced will, other things being equal, be very marked only in long prosenchymatous tissues, and in a mass of parenchyma relatively less marked.

² Sachs' *Physiology of Plants*, Engl. ed. 1887, pp. 651-2.

anther-tube, in consequence of the general shortening. After a few minutes the filaments again elongate, returning to their original arched position. They are now once more irritable. Again, if one of the filaments be freed, and stimulation be applied to its outer surface, this convex surface becomes concave, returning to the original convex form during recovery. But if the inside of the filament be touched the reverse action takes place, that is to say, the inner side now becomes strongly concave. On excitation, the expelled water passes from the excited cells into the intercellular spaces. This excitatorily expelled water was observed by Pfeffer to well forth from the cut end of the filament. He also studied the contractile shortening, using a magnification of one to two hundred diameters, and found it to amount in various cases to from 8 to 22 per cent. of the original length.

It will be seen that in this case of *Cynerea* we find those conditions of extensibility and elasticity which are so characteristic of muscle, to be present, though not in an extreme degree. In muscles, contraction is brought about by redistribution of fluid, as between the constituent isotropic and anisotropic elements. In *Cynerea*, also, the phenomenon is not altogether different, for here it is known to be brought about by a redistribution of water as between the cells and intercellular spaces. It will be well to remember here that the effect of stimulus acting on an organ from without is, in general, to force the expelled water inwards, whence it may be driven, through intercellular spaces and fibro-vascular elements, out of the excited region, into the interior, or the rest, of the plant. On the cessation of stimulus, the water, thus expelled under tension, returns into the contracted cells, and this fact aids the process of recovery.

I have already demonstrated in the beginning of this chapter the contraction and concavity of the excited side of an organ, in response to unilateral stimulus. The responsive concavity of either side of the filament of *Cynerea* when excited, as observed by various investigators, is simply an instance of this.

The filaments of *Cynerea* cannot be regarded as, strictly speaking, radial organs, for their tangential diameters are nearly twice as much as the radial, hence their response cannot be considered as entirely unaffected by differential action on the two sides.

I shall now proceed to demonstrate that the radial organs of plants exhibit response by longitudinal contraction, just as muscle is seen to contract under stimulus, and that such contraction, so far from being distinctive of any specific plant, or of any organ of such plant, is characteristic of all radial organs of plants in general. It will also be shown that the lateral response of anisotropic organs is to be regarded as an instance of differential longitudinal contraction.

The Kunchangraph.—But it is here necessary to give a full account of the experimental arrangements by means of which this demonstration has been rendered possible, and to show that the results thereby obtained are reliable, consistent, and capable of the highest quantitative exactitude. In this ‘Kunchangraph,’¹ which records the contractile response of the plant, as the Myograph that of the animal, we have, first, the plant chamber proper, which is made small, in order that the conditions, and variations of conditions, whose effects are to be studied, may be easily and rapidly changed. The lower end of the organ, securely held by means of a cork, is immersed in a small test-tube containing water, and fixed in the middle of the base-board. The upper end of the organ is connected with one arm of the Optic Lever by means of a thread. The fulcrum-rod, carrying the reflecting mirror, projects outside the chamber. A thin glass cylinder, not shown in the figure, may be used to cover the projected portion of the fulcrum-rod, thus protecting the mirror from the disturbance caused by air-currents.

One important condition which I find essential to the maintenance of uniformity of sensitiveness is that the plant shall be surrounded by a moist atmosphere, whose humidity is constant. An air-bag is kept under suitable pressure, and

¹ From the Sanskrit *kunchan* = contraction. The *u* is here pronounced as in *full*.

air, bubbling through water, is made to enter the chamber through an entrance-pipe. The exit-pipe is connected with an aspirator. By proper manipulation of the stop-cocks of the air-bag and the aspirator, a gentle stream of humid air is kept in constant circulation through the chamber. A modification of this arrangement enables us to study the effect of various gases and vapours on the excitability of the organ. A series of responses is first taken, under normal conditions, that is to say, when the plant is surrounded simply by a moist atmosphere. By now turning a three-way tap in a given direction, the water-vapour can be made to pass through a vessel filled with a given gas, before reaching the plant chamber. Or the pure gas can be introduced alone. The series of responses now obtained shows both the preliminary and the permanent effects of the gas. For it is now easy, by means of the three-way cock, to shut off the gas, and to re-establish the first or normal condition. The responses next given afford an indication of the after-effect of the gaseous reagent. It will be seen that by this means the effects of various gases and vapours can be studied with the greatest ease (fig. 35).

The next point to be dealt with is that of the mode of application of a uniform or graduated stimulus. For electrical stimulation we may use induction currents. For this purpose, a sliding induction coil of Du Bois-Reymond's pattern is used. The intensity of the shock is here graduated, by bringing the primary coil nearer and nearer to the secondary. Non-polarisable electrodes make suitable connections with the upper and lower ends of the organ. Electrical stimulation is often preferable on the whole, but unless vigorous specimens are used, it is apt when strong to induce fatigue. This may be avoided by the use of moderate stimulus and high magnification. Or we may, if desired, use thermal stimulus, which is effected by means of heat generated in a continuous length of thin German-silver wire which surrounds the whole length of the specimen, in the form of a cylindrical cage. This wire cylinder is fixed appropriately

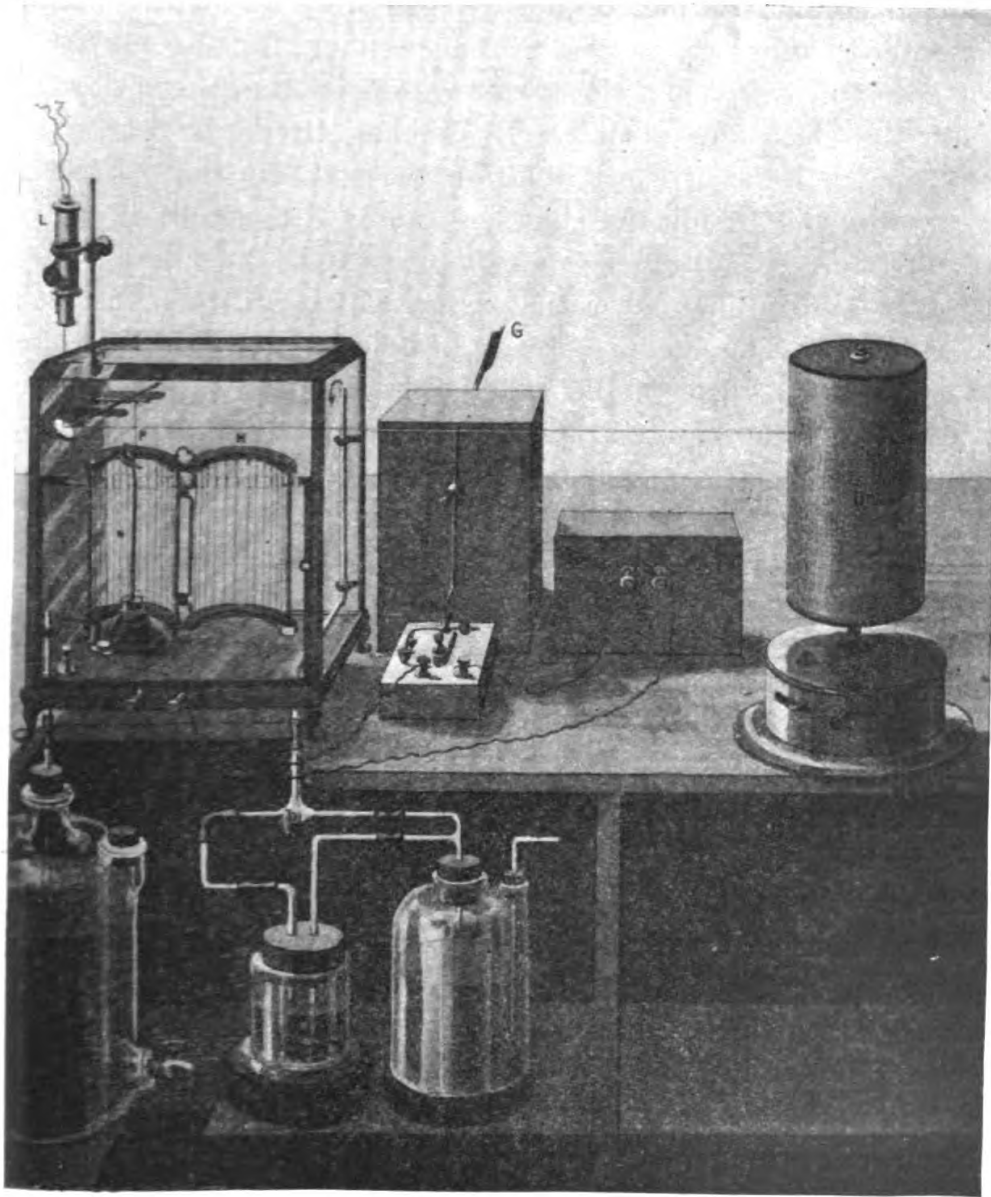

FIG. 35. The Kunchangraph

P, The plant enclosed in semi-cylindrical wire heating cage, H, seen open. The plant is attached to the Optic Lever. Light proceeding from focussing tube, L, after reflection from optical mirror, M, falls on the recording drum, D. Stimulation is periodically effected on closure of electrical circuit, containing storage-battery, S, by the rotating rod, R. Air from bag not shown is passed through water-vessel to right, and circulated through plant chamber. The vessel to left is the aspirator. The middle vessel contains ether or other chemical substance, which is made to displace air in plant chamber, by manipulation of stop-cock. G, the clock-governor.

in wooden or ebonite forms, which are made in halves and hinged, so that one half of the cylinder may be swung back in order to afford easy access to the specimen, for the purpose of adjustment. When closed, the wire is in complete circuit with the electrodes outside. By sending through this wire a strong current of short duration, the sudden rise of temperature generated in the chamber causes the stimulation of the tissue. This heat is quickly dissipated, again, by the stream of air charged with vapour, which is in constant circulation. The effectiveness of stimulation will depend on the range, and also on the suddenness, of the temperature-variation. The required thermal stimulus is thus most easily effected by electrical means, the degree of rise of temperature being determined by the strength of the current acting on the heating circuit, and the requisite suddenness of variation being the result of temporary completions of the circuit of definite and short duration. This mode of stimulation, I shall, for convenience, designate as stimulation by thermal shocks.

It is very difficult, using only the hand, to attain the necessary precision in making these brief and equal completions of the circuit several times in succession. Hence, the stimulus not being strictly uniform, the responses are apt to become unequal. I have overcome this difficulty, however, by the construction of a closing key regulated by clock-work, which enables successive stimuli, of equal intensity and duration, to be applied automatically, at predetermined intervals. This is accomplished by means of a clockwork arrangement, which enables uniform and successive electrical or thermal shocks to be applied, while at the same time the intervening periods between successive shocks may be so adjusted as to allow for complete recovery. A radial arm, carried on the axle-rod of the clock, at each complete revolution strikes against a balanced key, which completes the electric circuit. The intervals of successive stimulation may be determined by regulating the speed of the clock. This may be done by suitably inclining the

blades of the air-vane governor (fig. 36). The diagram shows the mode of making successive closures of the electric circuit for giving thermal shocks. And the same arrangement serves to close the primary of the induction coil. The duration of stimulus, depending upon that of the closure of circuit, may be adjusted by varying the length of the radial arm. The effective intensity of stimulation may be increased by applying three or four shocks in rapid

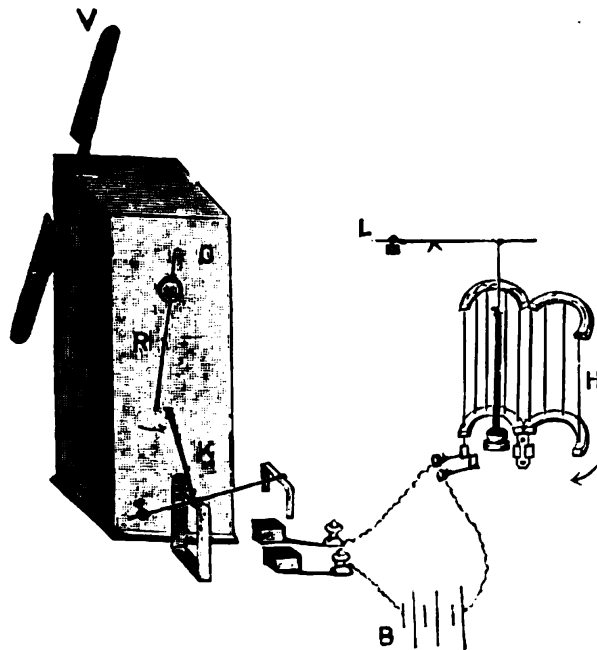

FIG. 36. Diagrammatic Representation of Apparatus for Periodic Stimulation of Plant

H, the wire cylinder made in hinged halves, periodically heated when the electric circuit is closed by tilting over of balanced key, K, when pressed by rod, R. V, air-vane of clock, by which period of rotation is adjusted.

succession, instead of one. For this purpose the radial arm carries at its end a small plate, of which the margin is divided into three or four teeth as the case may be. It is thus possible to produce a stimulation which consists of the requisite number of summated shocks. Or, instead of the clock, we might, for the purpose of producing brief and definite closures, have a metronome. But this is a less perfect arrangement than that of the clock.

By wrapping a sensitive film round the recording drum, all these response-records may be obtained photographically. Thus the whole process of stimulation and its record may be rendered automatic. The records given in this and succeeding chapters have been obtained sometimes by photography, and sometimes by employing the simpler process of following the spot of light with a recording pen.

From a knowledge of the magnification produced by the Optic Lever, and the height of the responses, it is easy to calculate the actual contraction produced by the stimulus. From the length of the specimen experimented on we can also determine the *coefficient* of responsive contraction—that is to say, the absolute contraction for unit length. When the magnification of the lever, the length of various specimens, and the strength of the stimulus are all kept constant, then the heights of the responses in different cases will be found to afford us a measure of the mechanical excitabilities of the different specimens.

Demonstration of universality of excitatory longitudinal contraction in radial organs.—I shall now describe my experiments on the longitudinal contraction of various radial organs. The first of these was performed on a straight radial *internode* of *Cuscuta*, which was attached to the recording Optical Lever in the usual manner. Tetanising shocks were given for twenty-five seconds at a time, from an induction coil, and the successive responses were obtained, at intervals of two minutes (fig. 37). The contractile effect persisted, even after the cessation of stimulation, for a period of five seconds, after which there was recovery, which was completed in a period of ninety seconds. It will be seen from the record that the successive responses were uniform.

I obtained similar responses from the *root* of a water-growing plant of the Bindweed family. Successive responses were obtained at intervals of two minutes, the stimulus in each case consisting of tetanising shocks of forty-five seconds. The maximum contraction was attained fifteen seconds after

the cessation of stimulus ; and recovery was completed after a further period of one minute. In this case the responses exhibited fatigue. It may be stated here that, speaking generally, the period required for recovery is dependent on the strength of stimulus. With moderate intensity of stimulation, recovery is complete within a comparatively short period. But it is protracted, or indefinitely delayed, when the stimulus is strong. Again, if successive stimuli be applied, before recovery is complete, the responses will be found to be additive.

In order to convey some idea of the amount of contraction produced by stimulus, I shall here give a detailed account of an experiment on longitudinal contraction, the specimen

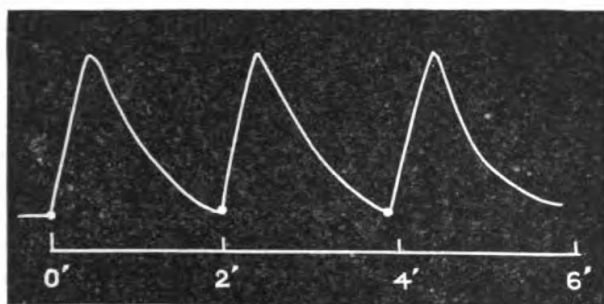

FIG. 37. Response of Stem of *Cuscuta* to Electric Stimulation

used being a young *stem* of the species of Bindweed (*Convolvulus*) already referred to. The length experimented on was 5 cm. On passing through this tetanising shocks of five seconds' duration, a maximum contraction was found to occur in the course of two minutes. The magnification used for record was fifty times, and the extent of contractile response recorded was 7.5 cm. Hence, the actual contraction was 1.5 mm., in a stem whose length was 50 mm. The contraction produced is thus 3 per cent. of the original length.

Similar contractile response may be obtained with other forms of stimulation, and I shall now describe that induced by thermal stimulus, the specimen used being the radial

style of *Datura alba*. Experimenting with the style has the special theoretical advantage that, owing to the soft nature of the tissue, the effect recorded is purely of longitudinal contraction. In specimens which have not this characteristic to the same extent, and which may be anisotropic, like the filaments of *Cynereæ*, the contraction is not always purely longitudinal. There is a tendency, owing to differential contraction, to the production of curvature.



FIG. 38. Photographic Record of Responses of Style of *Datura alba* to Thermal Stimulation

For these reasons, a limp and thread-like style fulfils the ideal requirements of an experiment for obtaining true longitudinal contraction. With this specimen of *Datura* I applied thermal stimulus at intervals of two minutes, in the manner already described. The records show how extremely uniform the responses are (fig. 38). The same longitudinal contraction may also be obtained from plants other than phanerogams. On applying electrical stimulus to the stalk of the fungus *Agaricus* I obtained a contraction of 2 per cent. of the original length.

Remarkable extent of contraction in coronal filaments of *Passiflora*.—There are some plants, again, in which the extent of the excitatory contraction is very great. For instance, the filamentous corona of *Passiflora quadrangularis* often gives a contraction of as much as 20 per cent.

It will thus be seen that not only is the phenomenon of longitudinal excitatory contraction present in all plants, but that such excitatory movements in some which are supposed to be insensitive, rival in extent those of the typically sensitive filaments of *Cynereæ*, which are said to exhibit a contraction of from 8 to 22 per cent.

In order to obtain a suitable record a magnification of only twenty to thirty times is necessary in the case of the highly excitable tissue of the corona of *Passiflora*. In less excitable specimens, a magnification of 100 would be enough. The advantage of relatively high magnifications in general

lies in the fact that they necessitate only moderate intensities of stimulation, which have the advantage of not fatiguing the tissue.

Modification of excitatory contraction by physiological conditions.—That these contractions are the expressions of true excitatory response is proved by the fact that they are modified by whatever affects the physiological condition of the tissue. Thus, for example, they undergo a temporary abolition under the action of anæsthetics, and a permanent abolition under the action of poisons. This will be demonstrated in more detail in a later chapter. They also exhibit very interesting modifications, according to the age of the specimen and the season of the year, as might theoretically have been expected. In experiments on this subject, undertaken with the filamentous corona of *Passiflora*, stimulation was produced by tetanising electric shocks, and the maximum contraction was measured by means of a micrometer. The following results show, in condensed form, the effect of age on excitatory contraction.

TABLE SHOWING EFFECT OF AGE ON EXCITATORY CONTRACTION
(Coronal filaments of *Passiflora q.*)

[Length of specimens, 21 mm. Time, February, *i.e.* end of winter.]

Age of Specimen.	Absolute contraction.	Mean contraction.	Percentage of contraction.
Flower already opened	$\left\{ \begin{array}{l} (a) \text{ 1.6 mm.} \\ (b) \text{ 1.5 mm.} \\ (c) \text{ 1.45 mm.} \end{array} \right.$	1.51 mm.	7.2 per cent.
One day before opening	$\left\{ \begin{array}{l} (a) \text{ 1.8 mm.} \\ (b) \text{ 1.7 mm.} \\ (c) \text{ 1.65 mm.} \end{array} \right.$	1.71 mm.	8.1 per cent.
Bud . . .	$\left\{ \begin{array}{l} (a) \text{ 1.65 mm.} \\ (b) \text{ 1.6 mm.} \\ (c) \text{ 1.5 mm.} \end{array} \right.$	1.6 mm.	7.6 per cent.

It will thus be seen that when the physiological activity of the specimen is at its greatest, that is to say, just before

the opening of the flower, the excitatory contraction is also at its maximum.

In order next to determine the effect of season on the excitatory contraction, we shall compare the mean percentage of contraction in winter with that obtained in spring, in the month of April. The average contraction in winter may be taken as 7.6 per cent. But in spring I obtained (1) with a specimen 12 mm. long, a contraction of 1.7 mm., *i.e.* 14 per cent. ; and (2) with a second specimen 10 mm. long, a contraction of 2 mm., *i.e.* of 20 per cent. The mean of these, 17 per cent., representing the contraction in spring, is thus seen to be about two and a half times that obtained in winter.

We have now ascertained the universal occurrence of longitudinal contraction in the organs of plants, and we have seen that lateral response cannot take place under diffuse stimulation in a strictly radial organ, owing to the antagonistic character of the equal and simultaneous responsive contractions on diametrically opposite sides.

Lateral response, however, as we have seen, will take place in a radial organ when stimulus is not diffuse, but unilateral. Such lateral response is only possible under diffuse stimulus, when the excitability of the two opposite halves is different, that is to say, when the organ is anisotropic. In such cases, as in the petioles of leaves, for example, the very striking lateral movement is simply the result of differential longitudinal contraction. The differentiation of the upper and lower halves is anatomically evident in the case of dorso-ventral organs. But the anisotropy may often be undistinguishable to the eye. For an organ, originally radial, may become molecularly bilateral, owing to the unequal action of external forces on diametrically opposite sides. It will be shown in the next chapter that such molecular differentiation gives rise to physiological differentiation, and there I shall be able to trace a continuity between the longitudinal response of radial organs and the lateral response of dorso-ventral organs through intermediate types.

SUMMARY

In a radial organ, unilateral stimulation causes contraction, and consequent concavity of the acted side.

Under diffuse stimulation there is no resultant lateral response, owing to the balanced and mutually antagonistic character of the contractions.

A radial organ under diffuse stimulation exhibits longitudinal contraction.

Longitudinal contractions are observed in the radial organs of all plants.

Such responsive contractions as seen in some 'ordinary' plants are strictly comparable in extent to those which are known to occur in the sensitive filaments of *Cynereæ*.

These excitatory responses are modified by all those agencies which affect the physiological condition of the plant.

G

CHAPTER VII

RESPONSIVE CURVATURE OF MOLECULARLY ANISOTROPIC ORGAN

Molecular anisotropy artificially induced by one-sided cooling—Cooled side less responsive—Diffuse stimulation causes concavity of the uncooled, that being relatively the more excitable—Local fatigue diminishes excitability—Diffuse stimulation now causes concavity of the unstrained side—Similar anisotropy induced in plagiotropic organs, by unilateral action of light—The lower, or shaded side of such organs relatively more excitable—Diffuse stimulation causes current of response from lower to upper, and also concavity of lower half—Responses of plagiotropic *Cucurbita* and *Convolvulus*—Differences in excitabilities of outer and inner surfaces of tubular organ—Complex response due to successive excitations of two antagonistic halves of an anisotropic organ—Response of spiral tendrils by uncurling—Response in certain cases by contraction of the spiral or curling—Writhing movement in spiral tendril under strong stimulation.

WE have seen that in a radial organ, owing to balanced actions, there is no lateral response to diffuse stimulus; and that in dorsi-ventral organs, where there is pronounced anisotropy—as seen in anatomical differentiation—lateral movement is produced by means of differential action. I am now about to demonstrate the fact that these phenomena are not sharply divided, but merge gradually one into the other, through intermediate types.

Molecular anisotropy induced by unilateral application of cold or of excessive stimulation.—If we take a hollow radial petiole of Gourd (*Cucurbita maxima*) growing erect, we shall find, on application of diffuse stimulus, that it gives no responsive curvature, but exhibits the simple longitudinal contraction of a radial organ. We may now take this petiole, and split it into two equal halves, throughout almost its entire length. We have now a single specimen bifurcated, the forked divisions being equal in every respect. One fork,

say A, is now immersed in ice-water, the other being dipped in water at the ordinary temperature. The two halves are next taken out of the water and bound together, from their free ends upwards, so as to make once more a single tube. The petiole is now held by the uncut part vertically, with a long index projecting downwards from its lower end. The petiole was, as will be remembered, originally radial; but now, by the local application of cold to one half, a certain molecular differentiation has been induced, and the particles in the cooled, or A half, are now therefore more sluggish and irresponsive than those of the B side. This induced molecular differentiation, moreover, is invisible to the eye, and had we not observed the process by which it was brought about, it would have been impossible, from mere visual inspection, to know which side had been subjected to cold. The application of diffuse stimulus, however, reveals it at once; for on passing electrical shocks along the length of the specimen, the relatively more excitable, or uncooled B half, becomes concave. It is clear, then, that at this moment the B half is the more excitable, and stimulus acts on it preferentially. But after long-continued stimulation, the B half becomes overstrained, and its excitability undergoes diminution or fatigue. At the same time, by means of repeated shocks, the sluggishness of the A half has been gradually made to disappear; that side now regains its excitability; and, the excitation of A becoming thus relatively greater, the curvature of the specimen is reversed.

I have said that excitability is diminished under the molecular strain caused by over-stimulation. I shall now demonstrate this by another and independent experiment. A new specimen, slit like the last, is taken, and one half, say A, is alone subjected to strong excitation, by sending electric shocks along its length. The two halves are again brought together, and on now subjecting the whole petiole to electric stimulation, it is found that the fresh, or previously unexcited, half is that which becomes concave, thus proving that the fresh half is the more excitable, and that strong or

long-continued stimulation diminishes the excitability of a tissue.

From these two experiments it will be seen that loss of excitability may be produced in, amongst others, two different ways. First, there is the molecular *sluggishness*, induced, as we have seen, by cooling, which is, however, only temporary, the original sensitiveness being restored on warming. Secondly, we may have loss of sensibility due to *overstrain*, owing to strong or long-continued stimulation. This strain-effect, with its attendant loss of excitability, may, if excessive, prove more or less permanent. It will thus be seen that in consequence of unilateral stimulation, a molecular differentiation is produced, in consequence of which an organ originally radial becomes physiologically anisotropic. The unstimulated portion of the organ is now the relatively more excitable, and on diffuse stimulation becomes concave.

Molecular anisotropy induced under natural conditions.—We shall next observe the induction of such molecular anisotropy under natural conditions. The stem of a young Gourd is at first erect and strictly radial ; but later it bends over, and then assumes a creeping habit. Under these conditions, its upper surface is subjected to the unilateral action of vertical light, the lower half being shaded and protected. The organ is no longer radial, then, but plagiotropic, and from what has been said already, we shall expect its upper or exposed surface, in consequence of the prolonged action of stimulus of sunlight, to be less excitable than the lower or shaded surface. This inference I have been able to verify by means of the electric mode of investigation. I find that on simultaneously exciting both sides of such a stem, a current of response flows from the lower to the upper surface ; hence it will be seen, according to the third law of electrical response, as enunciated at the end of Chapter III., that this lower side is the more excitable, and ought to become concave under diffuse stimulation.

Such induced concavity in response to diffuse stimulation I have found in the case of various plagiotropic stems, for

example, in those of *Cucurbita* and *Convolvulus*. In order to demonstrate the greater contraction of the shaded side—which is seen as responsive curvature—while eliminating the effect of gravity, I have employed two different modes of experiment. In the first, stems are held with their tips vertically downwards, and electric shocks are passed through them; a curvature is then produced by the greater contraction of the shaded side, in consequence of which the free end of the stem is lifted up against the force of gravity. The second method consists in supporting the stem horizontally in such a way that the plane which divides the previously shaded and unshaded sides is vertical: on strong stimulation, the stem now moves in the horizontal plane, in a definite direction which is determined by the induced concavity of the shaded and more excitable side. Here we see the plagiotropic stem behaving like the pulvinus of *Mimosa*, the more excitable side becoming concave under diffuse stimulation in both.

Response of plagiotropic stems.—In order to obtain a series of responses, made from plagiotropic stems, demonstrating their similarity to those obtained from the pulvini of sensitive plants like *Mimosa*, we may use specimens of *Cucurbita* or *Convolvulus*, selecting the last internode of the stem as the most sensitive. The cut ends of the specimens are placed in water, and the abnormal turgidity thus produced may sometimes at first cause erratic responses; but after a while these become very regular. Stimulation is produced by thermal shocks, the specimen being held erect, within an inclosing spiral of heating wire, in the manner already described. The responses are now given in the form of lateral movements, which are recorded by the use of a magnetically controlled horizontal recorder, fully described in a subsequent chapter. The responses might easily have been recorded also by the use of the Optic Lever, which was employed in the case of *Mimosa*. But my object in the present case was to eliminate as far as possible the effect of gravity, and this could not have been done by

holding the specimen horizontally, as would be necessary in using the Optic Lever.

In the records obtained with *Cucurbita* (fig. 39), it will be noticed that the recovery was not very complete, even though an interval of five minutes elapsed between successive

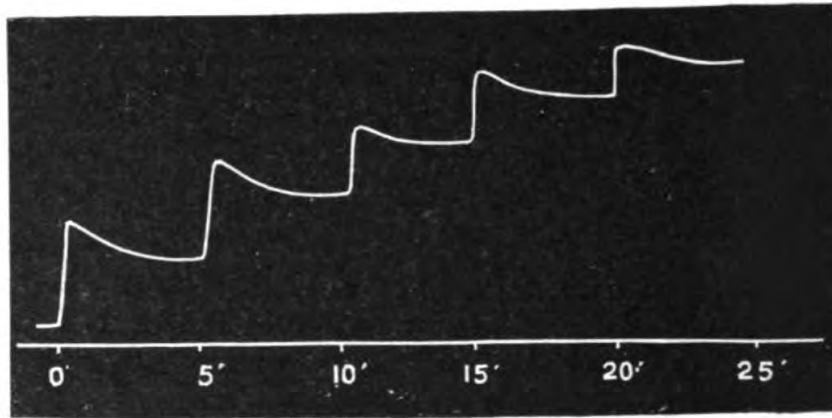

FIG. 39. Responses of Plagiotropic Stem of *Cucurbita*

stimuli. In the case of *Convolvulus* (fig. 40), however, the recovery was almost complete in two minutes. But of the two, *Cucurbita* was the more sensitive, *Convolvulus* requiring a stimulus about four times as great, in order to produce the

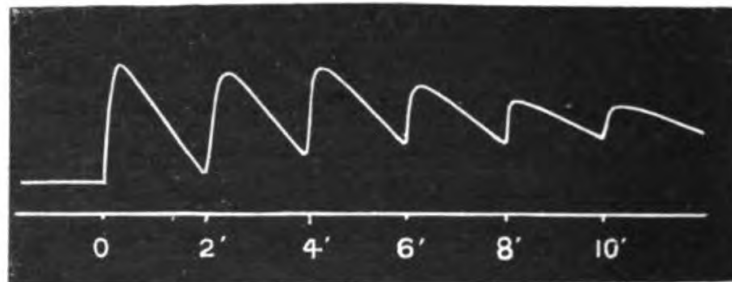

FIG. 40. Responses of Plagiotropic Stem of *Convolvulus*

same amplitude of response. Both records show evidence of fatigue.

Response by collapse of divergent halves of *Allium peduncle*.—The effect of the anisotropy thus induced by the unilateral action of light may also be exhibited by taking

the hollow petiole of *Cucurbita* or the peduncle of *Allium*. Of these two specimens, the latter is the more sensitive, and reacts far more quickly. It will be observed that the outside of such tubular organs growing erect has been long exposed to light, whereas the inside has been protected from it. If we now split the specimen for a few centimetres of its length, then the freed halves, owing to the differences of

tension as between the outside and inside, will be found to curve outwards, that is to say, the inner side becomes convex. In the previous experiments, where the two halves were rejoined, anisotropy having been induced, we observed the effect of the relatively greater contraction of one of the two halves. But we are now about to study natural differences of excitability as between the inner and outer surfaces of each half. As the outer surface has already been exposed to the continuous action of stimulus of light,

we should expect the inner or protected side to be relatively the more excitable. The effect of diffuse stimulus should then be to straighten the curled halves, by producing a greater contraction of the more excitable inner side, which is at present convex. The experiment is carried out by dipping the freed ends in a beaker of water, the undivided portion being held in a clamp (fig. 41). Electrical connections are made with the upper part, and with the water in the beaker in which the free ends of the specimen are dipped. After passing a few shocks from an induction coil

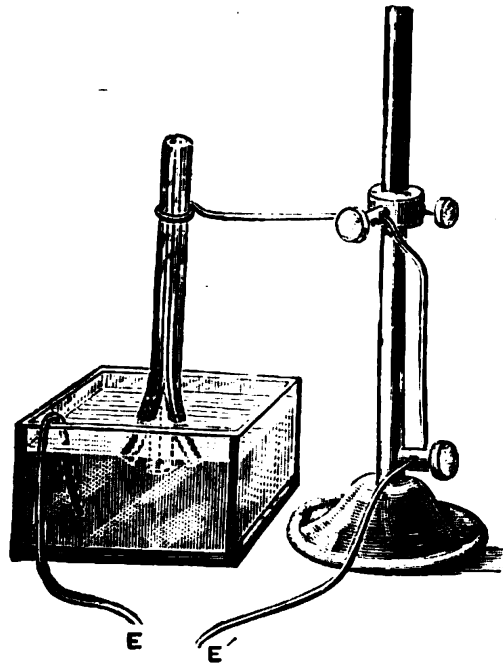

FIG. 41. Response of Bifurcated *Allium* Tube by sudden Collapse
E and E' are connected with induction coil, by means of which the plant is stimulated electrically.

through the specimen, the divergent curled portions are seen to fall together, the observed effect being very like the sudden collapse of the divergent leaves of a gold-leaf electroscope. The experiment described becomes very striking when magnified by optical projection.

In the response-phenomena of anisotropic organs we meet with instances in which the continuous action of stimulus gives rise to alternate movements up and down. One factor of this obscure phenomenon may be determined by a modification of the experiment just described. Since we have seen that in a typically anisotropic or dorsi-ventral organ the excitabilities of the two halves are different, there must also exist a difference of time-relations as between their responses; that is to say, the beginning of response, the attainment of the maximum, and so on, will take place earlier in the one half than in the other. The response of the organ as a whole will thus be the resultant of the curves of response of its constituent halves; and since these latter differ, in amplitude and phase, we are in a position to understand how we may have great variations in the resultant effect. In order to show the difference of phase I shall take a simple case of induced anisotropy. One half of the bifurcated peduncle is cooled by immersion for a time in ice-water. The two halves are now dipped in a vessel of water, as in the last experiment, and electric shocks are passed through the peduncle as a whole. It will now be found that we obtain successive, instead of simultaneous, excitations of the two halves. For the uncooled half responds at once, whereas the cooled half only begins to respond after ten or more seconds. It is thus clear that had the two halves been joined to form a single organ, the observed response would have been a compound of these two constituent responses. The first part of this response would be due to the active contraction of the uncooled half, but, later, the contraction of the cooled half would reverse this first movement.

Response by uncurling.—Having now studied the anisotropy, and consequent differences of excitability, caused

by the unilateral stimulus of light, we shall next proceed to consider the similar effects induced by unilateral mechanical stimulation. We shall find, if we touch a tendril unilaterally, that it responds to this one-sided stimulus by the concavity of the excited side, and we obtain a curvature. After a more or less prolonged contact, this curvature becomes fairly permanent. Thus, by means of unilateral excitation, the originally radial tendril—like the unilaterally excited plagiotropic organ—has been made to become bilateral and anisotropic, and the excited concave surface should now be relatively less excitable than the convex.

A tendril of *Passiflora* was taken, in which a curvature of half a spiral had been induced by stimulus of unilateral contact. The straight lower end of the tendril was now fixed in a clamp, the hooked end being attached to the Optic Lever. A spiral of tinsel made one of the electrical contacts at the hooked end, the other being made at the clamp. An electrical shock of moderate intensity was now passed through the length of the tendril. From what has been said already, we should expect that diffuse excitation would now produce concavity of the more excitable, or convex, side of the hooked tendril. We should expect, in other words, that the electric stimulation would have the effect of undoing the existing curvature, or straightening out the curved tendril. Such a responsive uncurling would, if it occurred, relax the tension on the Lever, and cause a concomitant movement upwards of the spot of light. On the cessation of stimulus, again provided this have been not too strong, there should be a restoration of the tendril to its original curvature. Greater intensity of stimulus, or stimulus of longer duration, should, other things being equal, produce greater responsive movement. And the recovery from such stronger stimulation would require a relatively longer time.

All these theoretical considerations are found fully verified in the record given below (fig. 42). It will there be seen that a stimulus of moderate electric shock, lasting fifteen seconds, produced a correspondingly moderate response of fourteen

divisions, and the recovery was completed in eight minutes. Stimulus of longer duration, that is to say, of twenty seconds, was next applied, and the response was correspondingly greater, that is to say, twenty-one divisions, recovery taking place in the longer period of eleven minutes; and finally, stimulus was applied for a still longer period, that is to say, thirty seconds, the response, of thirty-five divisions, being now

correspondingly great, and recovery requiring sixteen minutes.

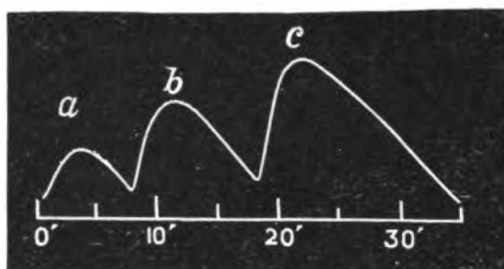

FIG. 42. Responses of Hooked Tendril of *Passiflora*

(a) Response to electric shock of fifteen seconds duration; (b) of twenty seconds; (c) of thirty seconds. Note increase in height of response and lengthening of period of recovery with increasing stimulus.

It will be noticed that in this case the amplitude of response and the period of recovery varied almost in direct proportion with the duration, determining the effective intensity of the stimulus. Thus the restoration to the original position of equilibrium takes place quickly when

the stimulus is feeble; but the period is prolonged, when stimulus is strong; or recovery may even be postponed indefinitely, after very strong stimulation. Recovery, when it does occur in such a case, may only be partial, a permanent after-effect being left.

The effects here described are obtained most easily by direct stimulation of the organ. But similar results may nevertheless be exhibited by means of transmitted stimulation. To show this, we may take a spiral of *Passiflora* tendril, and apply strong electric stimulation through two points at its lower end. The transmitted stimulus, reaching the free spiral end, causes response by uncurling, and variation of the twist.

Response by curling.—In the case of the experiments just described, stimulus has been found to produce uncoiling of the spiral. From this, however, it must not be too hastily concluded that similar effects will ensue in every case. The

fundamental phenomenon to be kept in mind is the greater contraction of the more excitable side. This might give rise to curling or uncurling, according to individual circumstances. I shall now describe an experiment which illustrates the opposite, or curling, action of this particular form of response.

If we cut a petiole of *Cucurbita* or a peduncle of *Allium* corkscrew-wise, so as to form a spiral strip, and pass electric shocks through this prepared specimen, the index at its lower end shows very energetic movement, but of *coiling*. Here we must bear in mind that the inside of the spiral of *Passiflora* has been formed by the stimulus of contact, and is thus the less excitable. Diffuse stimulation in such a case, therefore, will cause the contraction of the convex surface, with the result of uncoiling. But in this spiral preparation of *Allium* or *Cucurbita*, it is the outside which has been long acted on by light, and it is the inner or concave side, therefore, which remains the more excitable. Hence, under stimulus, it is this more excitable inner side which becomes still more concave with the result of coiling (fig. 43).

Writhing movements of excited spiral tendril.—The most striking of this series of results were obtained, however, with long spiral tendrils of *Passiflora*, which were not too old. Very strong stimuli of electric shocks were sent through the entire length of these spirals, with results so striking and unmistakable as to furnish a final refutation of the popular assumption which distinguishes between animal and vegetable tissues as relatively motile and non-motile. These

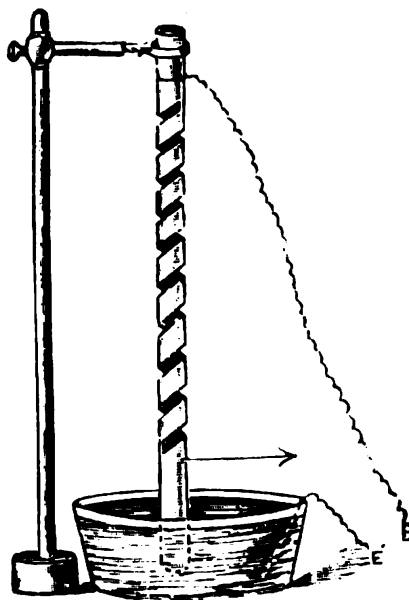

FIG. 43. Response by Coiling of spirally-cut *Allium* Peduncle
Through E and E' are passed electrical shocks from an induction coil.

spiral tendrils, on receiving electric stimulation, began instantly to uncurl—their free ends, as they did so, sweeping through large arcs—and then straightened themselves out. Startling as this was, however, it was not all. I have already alluded to the phenomena of successive excitations and alternating fatigue, of the different sides of an anisotropic organ, under continuous stimulation. Often, owing to this peculiarity, the tendrils after their first uncoiling action showed, though with less vigour, the movement of recurling. These violent contortions were strongly suggestive of the writhing of a worm under torture.

Though the response to the stimulus of strong electrical shock is the most vigorous, yet this responsive movement of uncoiling can also be obtained by other forms of stimulation, such as the thermal and chemical. For this purpose we may dip the spiral tendril into hot water, or into dilute sulphuric acid. The differential contractile response may then be observed.

We have thus traced out in unbroken continuity the various types of mechanical response as seen in plants. To begin with, we have observed the responsive longitudinal contraction, pure and simple, of a strictly radial organ. Next, in the case of plagiotropic stems, the same longitudinal contraction, but acting differentially, produced lateral movement, the differential action being the result of induced molecular anisotropy and consequent difference in the excitabilities of the two halves, as a result of which, a plagiotropic stem functions as a diffuse pulvinoid. From this we pass to the anatomical anisotropy, which may be observed in the dorsi-ventral petioles of ordinary leaves. Here we find a tendency in the diffuse pulvinoid to become contracted to certain definite areas; and the responsive movement, in such cases, also, is brought about by differential longitudinal contraction of the upper and lower halves. And, finally, we discover the culminating type of such differentiation for the purpose of motile efficiency, in the pulvinus of the so-called 'sensitive' plants, where also responsive movement is brought about by differential longitudinal contraction.

It has thus been clearly established that there is no specific sensibility of the dorsi-ventral organ which is in any way distinct from that of radial organs—the responsive lateral movements of leaves being merely a special or differential form of the longitudinal contraction which has thus been found to be widely prevalent.

SUMMARY

When the two sides of an organ become unequally excitable by reason of molecular differentiation, a resultant lateral response, due to differential longitudinal contraction, is obtained, the more excitable side becoming concave. This molecular differentiation may be induced artificially by unilateral application of cold, or of strong stimulation.

This molecular differentiation occurs under natural conditions in plagiotropic stems, the upper surface being acted on by stimulus of vertical sun-light.

In a hollow tubular organ, such as the petiole of *Cucurbita*, or the peduncle of *Allium*, the outer surface, which is constantly acted on by light, is found to be less excitable than the inner surface.

The spiral formed, by unilateral stimulus of contact, in such tendrils as that of *Passiflora* is less excitable on the already stimulated, or concave, than on the outer, or convex, side; diffuse stimulation, causing greater contraction of the more excitable convex side, gives rise here by differential contraction to the responsive movement of uncurling.

Molecular anisotropy culminates in dorsi-ventral inequality, as seen in the petioles or in the pulvini of leaves. Here, too, diffuse stimulation causes lateral response, by inducing concavity of the more excitable half.

Dorsi-ventral organs do not possess any specific sensibility different from that of radial organs, the lateral responsive movement being the result of the differential longitudinal contraction of two unequally excitable halves.

The universal law of responsive movement is : **Mechanical response takes place by the concavity of the more excited side.**

CHAPTER VIII

RELATION BETWEEN STIMULUS AND RESPONSE

Ineffective stimulus becomes effective by repetition—Two types of response in contractile animal tissues, cardiac and skeletal—Response of cardiac muscle on 'all or none' principle; parallel case in *Biophytum*—In skeletal muscle, increasing stimulus causes increasing response, which tends to reach a limit --Parallel results in longitudinal and electrical response of plants—Effect of superposition of stimuli—Tetanus.

THE application of stimulus to a tissue initiates a series of events which culminates in the contraction of the excited cells. It is easily seen that a certain minimum intensity of stimulus is necessary in order to bring the excitatory condition of the tissue to the threshold of response. In the case of the electrical stimulation of *Biophytum*, we found this minimum stimulus-intensity to be of a very definite order. In the production of longitudinal response also a certain minimum amount of stimulus, either electrical or thermal, is necessary in order to evoke response.

Additive effect.—A thermal shock which is singly ineffective, may become effective by repetition. Below is given a record which shows this. A single shock produced by the closure for one second of an electrical circuit, acted on by six volts, was found to be ineffective in inducing mechanical response. But when the same stimulus was repeated six times in succession, it gave rise to a moderately large response (fig. 44). This additive effect I also find in the electric response of plants (fig. 45). And it is well known in the case of animal tissues.

In the case of contractile animal tissues, again, we have two distinct types of response. The first is that of cardiac muscle, which is said to be on the 'all or none' principle. That is to say, on applying a gradually increasing stimulus,

we presently arrive at the threshold of response, where the response becomes at once the maximal possible. In this case, then, the minimal response is also maximal. We shall



FIG. 44. Ineffective Stimulus made Effective by Repetition

The line to the left shows that single stimulus produced no mechanical response. The curve to the right shows the effect produced when stimulus had been repeated six times.

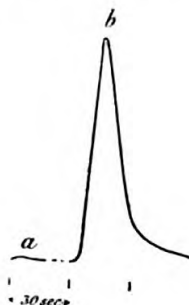

FIG. 45. Additive Effect in Electrical Response

(a) A single stimulus of 3° vibration produced little or no effect, but the same stimulus when rapidly superposed thirty times produced the large effect (b). Leaf stalk of turnip.

find, in Chapter XXII., that an exactly similar type of response is afforded by *Biophytum*, where the minimally effective stimulus suddenly produces maximal effect.

Relation between stimulus and response in animal and vegetable.—The second type of contractile response is shown by skeletal muscle. Here, after reaching the threshold of response, increasing stimulus causes increasing response, which, however, tends to reach a limit. Exactly parallel effects are seen in the case of plants, in the longitudinal responses exhibited by different radial organs.

The experimental method by which this is demonstrated is as follows: The intensity of thermal stimulus may be appropriately increased, as has been explained, by increasing the value of the heating current, the circuit being always closed for a certain definite time, say one second. The resistance of the heating coil being kept constant, the thermal effect is proportional to the square of the current. If, then, we use currents which increase as the square root of the natural numbers, the successive thermal effects will be increased in arithmetical progression. The currents to be used are previously adjusted, by means of an ammeter, and

suitable external resistances. In this way I have obtained successive responses to thermal stimuli, which increased in

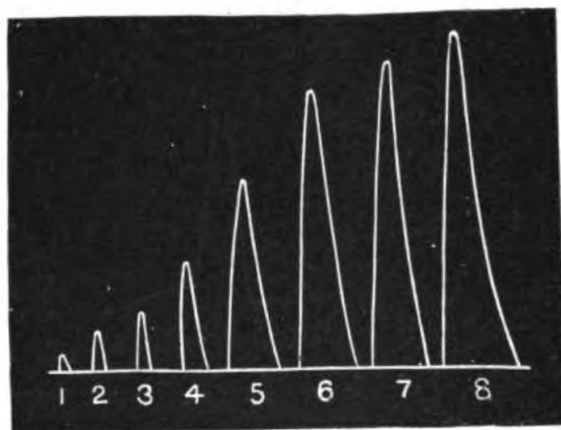

FIG. 46. Mechanical Responses to Stimuli increasing in Arithmetical Progression

arithmetical progression. And we see from the records in what manner the corresponding responses undergo an increase (fig. 46).

It will be seen from this figure that with a stimulus represented by unity, the response was 1.5 division. With a stimulus twice as great, the corresponding response was slightly greater than twice as much, that is to say, it was 3.5.

The intensity of response went on increasing, but with special acceleration when the stimuli were four and five.

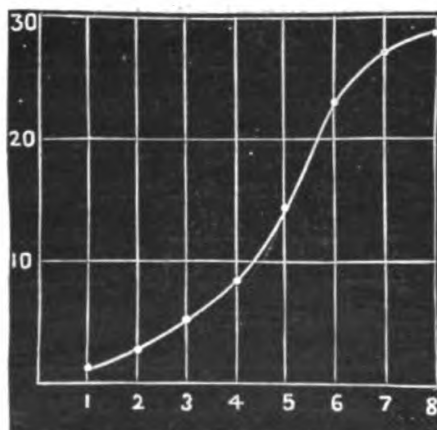

FIG. 47. Curve showing Relation between Stimulus and Response

The abscissa represents the stimulus, and ordinate the height of response.

After the stimulus of six there was a tendency for the response to approach a limit. The subjoined curve (fig. 47) shows the relation between the increasing stimuli and the corresponding responses.

Another interesting feature of these response-curves is one which has already been referred to, the prolongation of the period of recovery with increasing stimulus. In the present case, with the stimulus of unit-intensity, the recovery was completed in forty seconds. With an intensity twice as great, it required fifty-six seconds for the restoration of equilibrium. And this increase in the period of recovery

continued progressively, until, with the stimulus-intensity of eight, the time required for restoration to the original condition was as much as 4 minutes 40 seconds, or exactly seven times that necessitated by unit-stimulus.

All these peculiarities are observable in the electrical responses of plants, as will be seen from the record in fig. 48. The stimulus applied was vibrational, and was increased in amplitude in successive experiments, from $2\frac{1}{2}^\circ$ to $7\frac{1}{2}^\circ$ to 10° to $12\frac{1}{2}^\circ$. It will be seen that here also as in the case

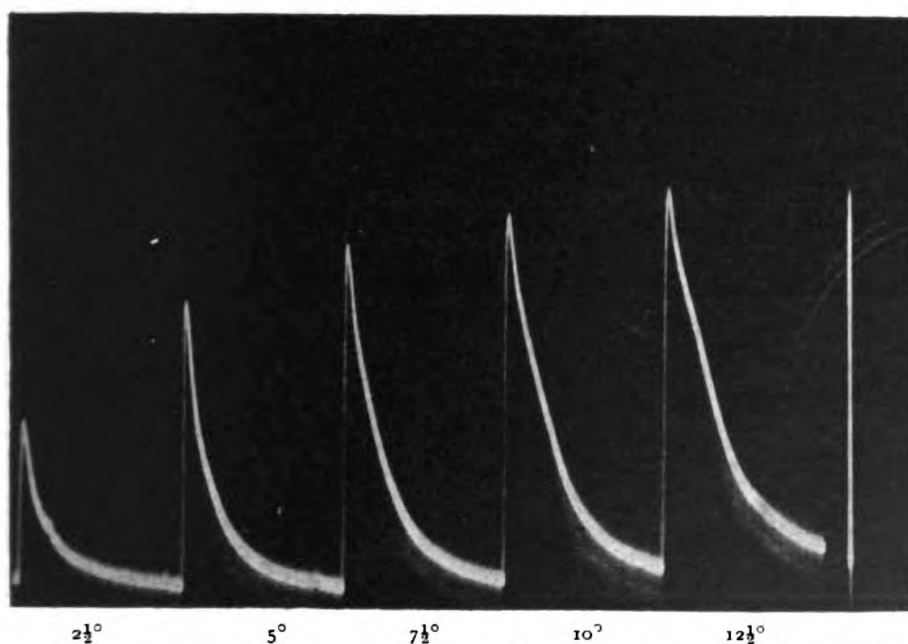

FIG. 48. Increased Electrical Response with Increasing Vibrational Stimuli (Cauliflower-stalk)

Vertical line to right = .1 volt. Stimuli applied at intervals of three minutes.

of the response of skeletal muscle, and the longitudinal response of plants, the amplitude of response increasing with increasing stimulus tends to approach a limit. These curves also show the increase in the period required for complete recovery, but in a manner different from that of fig. 46. In fig. 46 the time-intervals were suitably increased, to allow of complete recovery. In the case of the electrical responses, however, stimuli were applied at equal intervals of time throughout. This was enough to bring about complete

H

recovery in the case of the first two responses. But afterwards it was not sufficient, so that recovery in the last three instances was more and more incomplete, as seen by the tilting upwards of the base-line of the responses (fig. 47).

TABLE SHOWING THE INCREASED E.M. VARIATION PRODUCED BY INCREASING STIMULUS¹

Angle of vibration.	Electromotive response
2.5°	.044 volt.
5°	.075 "
7.5°	.090 "
10°	.100 "
12.5°	.106 "

Tetanus.—Having now observed the effect produced by single stimuli, we shall proceed to study the effects of similar

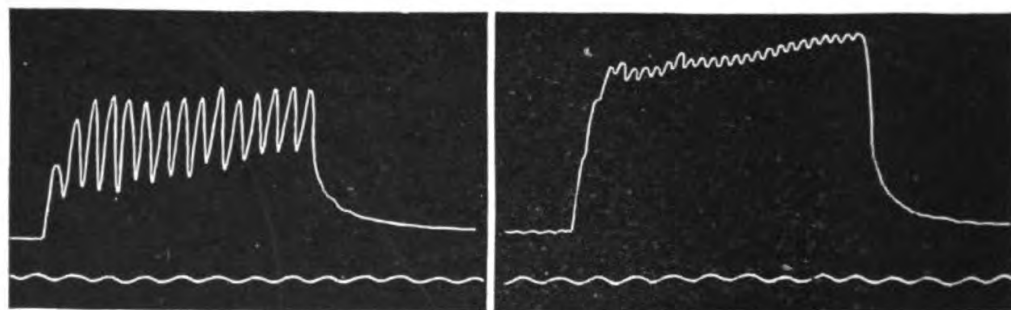

FIG. 49. Genesis of Tetanus in Muscle

Record to left shows incomplete tetanus, with moderate frequency of stimulation. Record to right shows tetanus more complete, with greater frequency of stimulation (Brodie).

stimuli when superposed. In muscle, we find that when stimuli succeed each other with great rapidity, the effect of the second stimulus becomes superposed on that of the first, which has not had time to disappear. The result is a fusion of effects, more or less complete. With moderate frequency of stimulation we thus obtain incomplete tetanus, which, with

¹ Bose, *Response in the Living and Non-Living*, p. 53.

increasing frequency of stimulation, becomes more and more complete (fig. 49).

As regards the mechanical response of plants, I obtained similar tetanic effects with the longitudinal contractions of the pistil of *Datura alba* (fig. 50). Stimuli were here applied at intervals of ten seconds, which was too short an interval, when compared with the natural period of recovery, lasting about two minutes. Hence we obtained incomplete tetanus. This incomplete tetanus became more complete when the stimulation-frequency was increased, successive stimuli being now applied at intervals of five seconds. It may be noted here that, in the tetanus both of muscle and of plant, the effects of individual stimuli, when rapidly succeeding, become so merged as to appear continuous. It is only after the maximum effect has been attained, that the individual effects of stimuli sometimes become distinguishable by slight oscillatory movements of the curve. In the case of rhythmic cardiac muscle, however, there is no tetanus; and similarly, as described in Chapter XXVII., we find no tetanus in the rhythmic vegetable tissue of *Desmodium*.



FIG. 50. Photographic Record of Genesis of Tetanus in Mechanical Response of Plants (Style of *Datura alba*)

SUMMARY

There is a minimal intensity of stimulus necessary to initiate response.

A stimulus, singly ineffective, becomes effective on repetition.

Increasing intensity of stimulus produces increasing response, which, however, tends to approach a limit.

The effects of rapidly succeeding stimuli in plant-tissues, as in animal, become fused, individual effects being then indistinguishable. A maximum contractile effect is then produced depending on the intensity of stimulus.

H 2

In all the above respects, we find that the responses of plants in general exhibit the closest parallel to the responses of skeletal muscle in animals.

But in the animal a different type of response is exhibited by certain rhythmic tissues like cardiac muscle. The response here is on the 'all or none' principle, and such a tissue cannot be tetanised. In the parallel instances of rhythmic vegetable tissues, the same characteristics are present; that is to say, the responses are on the 'all or none' principle, and there is no tetanus.

PART II
MODIFICATION OF RESPONSE UNDER
VARIOUS CONDITIONS

CHAPTER IX

ON THE UNIFORM, FATIGUE, AND STAIRCASE EFFECTS IN RESPONSE

Uniform response in plants—Staircase effect—Fatigue due to molecular strain—Fatigue in plant-responses—Periodic fatigue—Fatigue under continuous stimulation—Explanation of anomalous erection of leaf of *Mimosa* under continuous stimulation—Conductivity and excitability of tissue diminished through incomplete protoplasmic recovery—Relatively greater fatigue in a motile than conducting organ—Disappearance of the motile excitability earlier than conductivity—Refractory period—Absence of responsive effect when stimulus falls within refractory period.

THE mechanical response of plants is fundamentally due, as we have seen, to those molecular changes which are the result of stimulus. These changes bring about contractions of the excited cells, in consequence of which water is expelled, and we obtain longitudinal response in radial organs, or lateral movement in dorsi-ventral organs, the latter being simply a special case of differential longitudinal contraction. On the cessation of stimulus the expelled water is reabsorbed, and the organ resumes its original position. In the case, for example, of the leaves of *Mimosa*, this position of equilibrium is, approxin. speaking, at an angle of 45° above the horizon, and this, for convenience, may be called the erect position. After a period of rest, then, molecular equilibrium being re-established, the protoplasm recovers its original properties, of which excitability is one, and response takes place on stimulation as before. This resumption by the leaf of its original position may thus be taken as a rough indication of the restoration of its original protoplasmic properties. But this is only true in a general way, for there may be cases, as we shall see, in which the apparent return of the leaf

to its original position is deceptive, and does not really indicate a complete protoplasmic recovery.

Uniform responses.—If the motile organ, however, be restored, by an appropriate period of rest, to exactly its original molecular condition, and therefore to its original condition of excitability, it is clear that we ought to be

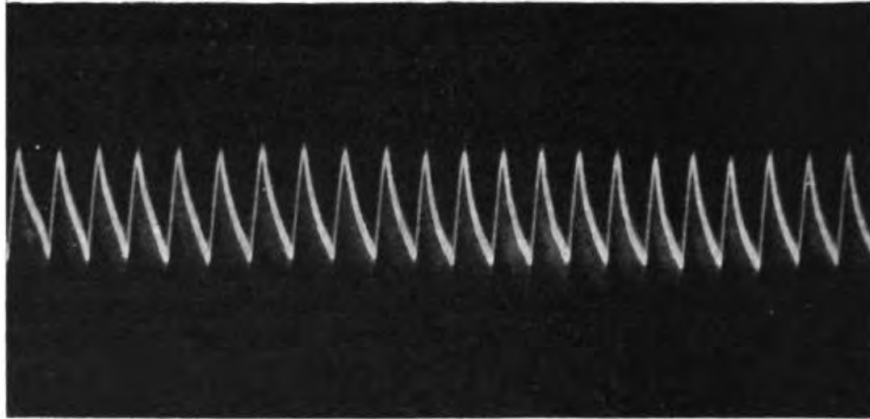

FIG. 51. Uniform Electrical Responses (Radish)

able to obtain uniform responses to uniform stimuli. That this is true has been shown to be the case, with regard to the responses of the leaflet of *Biophytum*, and the longitudinal contractions of various radial organs (figs. 18 and 38). By taking electromotive instead of mechanical responses, I obtained a similar result, of uniform responses to uniform

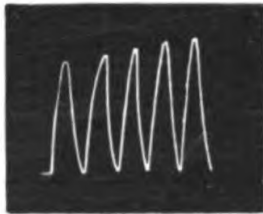

FIG. 52. Staircase Effect in Longitudinal Mechanical Response of Plant (Style of *Eucharis*)

stimuli, from various species of plants (fig. 51). In the case of muscle, also, the responses are found to be uniform, if intervening periods of rest be allowed, sufficient for full recovery (fig. 9).

'Staircase' effect.—It is sometimes found that a tissue falls into a sluggish condition, and successive stimuli, by increasing molecular mobility, have the effect of gradually enhancing the responses, which are seen to increase in a 'staircase' manner. I give here an instance of this effect (fig. 52) in the case of longitudinal response, obtained with a style of *Eucharis* Lily.

Fatigue.—It has been said that, when sufficient time is allowed for protoplasmic recovery, the responses are uniform, but that, if sufficient time be not allowed, molecular recovery will be incomplete, and the tissue will remain in a strained condition. Under these circumstances, it is obvious that there will not be a complete restoration of the original protoplasmic excitability, hence successive responses will exhibit a diminution or fatigue. The following record (fig. 53) shows this in the case of longitudinal response. Uniform stimuli were first applied at intervals of one minute, by which time the recovery was complete; and these responses of twenty divisions are seen to be large and uniform.



FIG. 53. Fatigue in Longitudinal Mechanical Response of Plant (Style of *Datura*)

In the case of the first pair of responses, a sufficient interval for recovery, namely one minute, was allowed. When the period allowed for recovery was reduced to half a minute, there was rapid fatigue; the second pair of responses shows this immediate effect; the third pair of responses are to the tenth and eleventh stimuli.

The stimuli were next applied at intervals of half a minute, and the response at once fell to eleven divisions. Now, owing to the effect of cumulative strain, the succeeding responses at this interval underwent continuous diminution, and had fallen as low as to five divisions at the tenth stimulus. In the next figure (fig. 54), fatigue is shown in the electrical responses of plants under the same conditions, sufficient time for recovery, that is to say, not being allowed. Similar instances of fatigue are well known in the case of muscle.

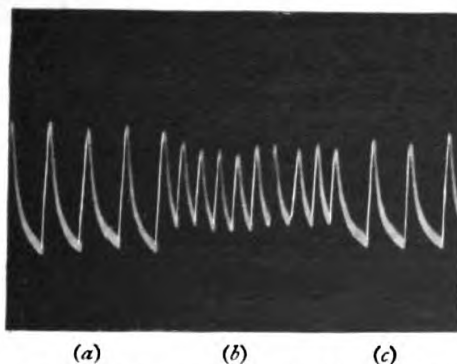

FIG. 54. Fatigue shown in Electrical Response, when sufficient Time is not allowed for Full Recovery

In (a) stimuli were applied at intervals of one minute; in (b) the intervals were reduced to half a minute; this caused a diminution of response. In (c) the original rhythm is restored, and the response is found to be enhanced to nearly its original value (Radish).

Fatigue being principally due to residual strain, it is to be expected that, other things being equal, strain will be more persistent with stronger stimulus, as has been shown in the last chapter. It was there shown also that the period required for recovery from a strong was more protracted than from a moderate stimulus. From this it follows that the stimulation-frequency which will exactly allow for complete recovery, and so give rise to uniform responses, in the case of a moderate stimulus, will not be sufficient for stronger stimulus. Hence, keeping the intervals constant, we may

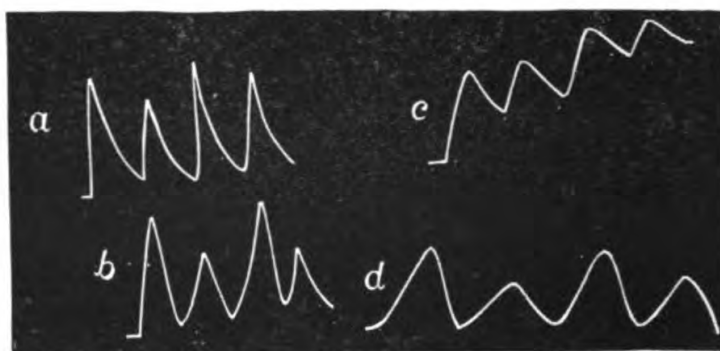

FIG. 55. Alternate Fatigue (a) in Electrical Responses of Petiole of Cauliflower ; (b) in Multiple Electric Responses of Peduncle of *Biophytum* ; (c) in Multiple Mechanical Responses of Leaflet of *Biophytum* ; and (d) in Autonomous Responses of *Desmodium*

obtain uniform responses to moderate, and diminished or fatigue-responses to strong stimulus.

There is another curious phenomenon, of alternate or periodic fatigue, which I have often observed in the response of plants. The simplest type of such periodic fatigue is that in which responses wax and wane, in regular alternation. Such alternate fatigue is sometimes seen in the electrical response of plants, the multiple response of *Biophytum*, and also in the autonomous response of *Desmodium* (fig. 55). Curiously enough, I have sometimes obtained similar alternate responses with the compound strip of ebonite and india-rubber, previously described. There are other cases of response in plants, where the variations are cyclic in type, that

is to say, they consist of groups of responses, which wax and wane alternately.

Fatigue under continuous stimulation.—In connection with the induction of fatigue under long-continued stimulation, I shall now anticipate certain results regarding the character of the responses given by matter universally—results to be described in detail in the next chapter. It will there be shown that if we represent a given molecular change, caused by stimulus, as positive, the continuation of stimulus will at first increase that change, until it has attained a maximum, after which, under the still continued action of the same stimulus, there will be a reversal or change to the negative. In a living tissue, then, where the incidence of stimulus causes contraction, we may be prepared to find that the same stimulus, long continued, will bring about a reversal of this effect, or, that is to say, a relaxation.

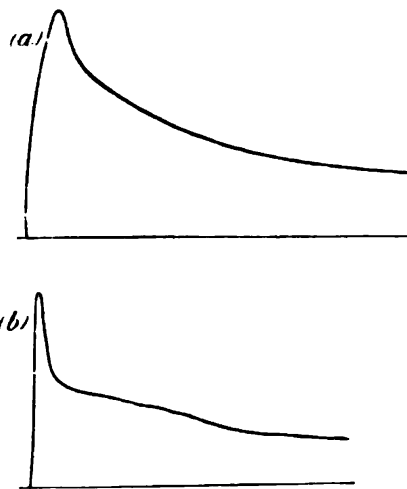

FIG. 56. Rapid Fatigue under Continuous Stimulation in (a) Muscle; (b) Leaf-stalk of Celery (Electrical Response)

In any case, such a reversal is illustrated in the corresponding phenomenon in contractile muscle. It is there found that, whereas the first effect of stimulus is contraction, the same stimulus, when too long continued, brings about relaxation to the original form. In the electrical response of plants under continuous stimulation, I also find this peculiar fatigue-reversal (fig. 56).

I have also obtained similar fatigue-reversals in the longitudinal response of radial organs. In fig. 56, (a), a series of tetanic electric shocks was continuously applied during a period of four minutes. The maximum contraction was attained in the course of one minute, after which there was a reversal, or relaxation. Under this condition of fatigue-

reversal, the tissue is incapable of the normal excitatory contraction, but after a period of rest of about seven minutes it

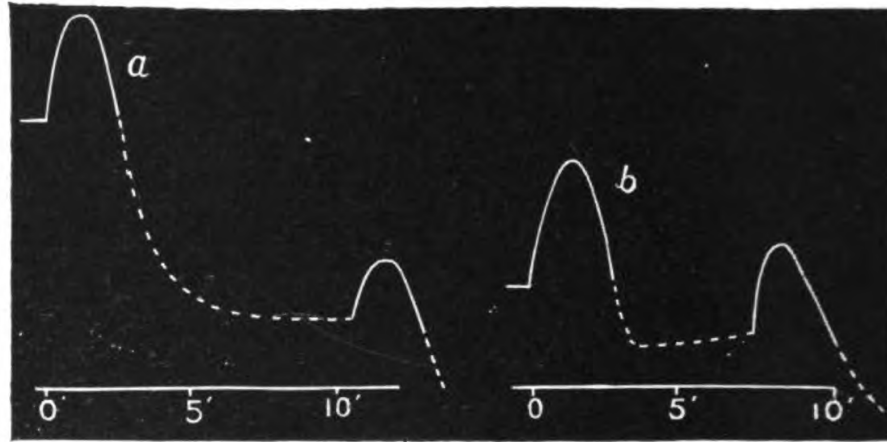

FIG. 57. Fatigue under long-continued Stimulation in the Contractile Response of Plants

(a) Stimulation by tetanising electric shocks; (b) stimulation by rapidly succeeding thermal shocks. Continuous lines represent action during stimulation; dotted lines represent after-effect (coronal filament of *Passiflora*, magnification forty times).

again gives response, which is at first normal, and then, after reaching a maximum, becomes reversed. The second response is, however, seen to be smaller than the first.

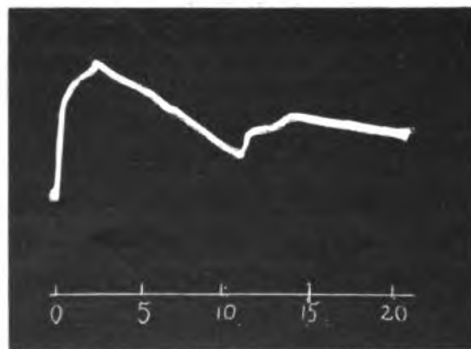

FIG. 58. Photographic Record of Periodic Fatigue under Continuous Stimulation in Contractile Response (Filament of *Uriclis* Lily)

I obtained parallel results under the action of rapidly succeeding thermal shocks (fig. 57, b).

I have already described curious instances of alternating fatigue exhibited in successive single responses to single stimuli (fig. 54). A very curious and interesting effect of this nature occurring under continuous electric stimulation, is shown in the accompanying photographic record (fig. 58) of responses given by the filament of *Uriclis* Lily. It will

there be noticed that the maximum contraction is attained in the course of three minutes, after which there is a fatigue-relaxation, which continues up to the eleventh minute. There then occurs a second, though much feebler, response, after which comes a slow and continuous reversal action.

So-called 'anomalous' response in *Mimosa*.—In connection with the subject of fatigue, I shall here enter upon the explanation of certain well-known responsive effects in the case of *Mimosa* which have hitherto been regarded as anomalous. It is generally found that an erect leaf of this plant is sensitive, that is to say, when stimulated it becomes depressed. In this depressed position it is apparently insensitive, hence we are apt to assume that the erect posture is one of sensitiveness, depression indicating the reverse. It will be found, however, that if a *Mimosa* leaf be continuously stimulated by successive blows or taps, in the manner of Pfeffer's experiment, the leaf will at first fall. But, though the blows be continued, the petiole will, after a time, return to its normal erect position. In this erect posture, however, further blows prove to have no effect upon it, the leaf being now insensitive.

I give above a photographic record of this effect in *Mimosa* (lower record, fig. 59), continuous stimulation in this case having been produced by tetanic electric shocks. It will be noticed that after its responsive fall the leaf returns to the erect position, in spite of the fact that stimulus is

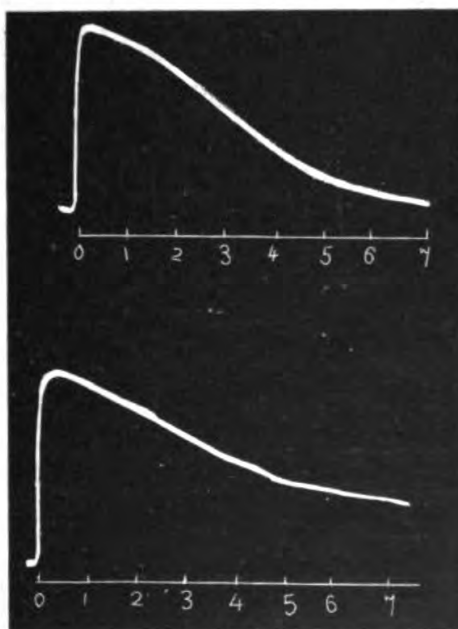

FIG. 59. Photographic Records of Normal Response of *Mimosa* to Single Stimulus (upper figure), and to Continuous Stimulation (lower figure)

In the latter case the leaf is erected in spite of continuous stimulation.

being continued. It is important to note that the two records were taken with the same specimen, and in immediate succession to each other. The first, or upper, records the response of the leaf to a single stimulus and its recovery; the lower gives the response to continuous stimulation. In appearance the two records are singularly alike. But though the leaf at the end of each response occupies the same position, the molecular conditions in the two cases are, as will be shown presently, entirely different, inasmuch as in the first, renewed response was immediately obtained, thus showing its sensitive condition; while in the second, the organ was insensitive, and could give no response until after a period of rest of about ten minutes.

The explanation of this apparent anomaly is quite clear from the experiments which have already been described, showing that under continuous stimulation the normal longitudinal contraction undergoes reversal and passes into relaxation, as is also the case with continuously excited muscle, the motile response of *Mimosa* being only an instance of differential longitudinal contraction. We obtain here also the usual sequence of first, normal contraction, and second, the fatigue-relaxation, or posture of erection.

To sum up, then, it is clear that our association of the erect position with sensitiveness is not always correct, for the leaf may assume this posture as the result of fatigue. That its position in this case, however, though outwardly imitating that of sensitiveness, is profoundly different, is at once revealed on application of stimulus. The leaf is now irresponsive. But if we allow it a period of rest—of some eight or nine minutes in summer, or double that time in winter—the internal molecular equilibrium is re-established. But of this internal readjustment the leaf gives no visible indication. It remains in the same unchangingly erect position. During the course of the cycle, then, it has passed from the normal erect to the normal depressed, and thence to the abnormal erect position. It next passes, without any outward change, from this abnormal erect to the normal erect position, after

a period of repose. And this return of the leaf to its normal condition is testified by its once more responding to stimulus.

Fatigue of conductivity and excitability.—It has already been pointed out that the protoplasmic properties of a tissue cannot be restored to their original condition after stimulation, without the intervention of a suitable period for the re-establishment of molecular equilibrium. This fact I shall now demonstrate by additional experiments.

The restoration of the normal protoplasmic condition in a tissue may be tested by observing the recovery of some of those properties which are capable of measurement. One of these is its conductivity, measured by determining the speed with which excitation travels through the tissue, the method of which determination will be fully described in Chapter XX. Under normal conditions this velocity is constant. If we excite the tissue, and measure the rate at which the excitation travels, and if we then allow a sufficient interval of rest for complete protoplasmic recovery and again determine this velocity, we shall find that the two are the same. But, if the necessary resting interval be not allowed, recovery being incomplete, there will remain a residual strain. The velocity of transmission of excitation will, under these circumstances, be found to be reduced.

Another protoplasmic property which is capable of measurement is the excitatory contraction seen in motile organs, measurable by the amplitude of response. We have seen that this amplitude is constant under normal conditions, and when sufficient intervening periods of rest are allowed. But diminution of the intervening resting period produces diminution of the amplitude of response.

From what has been said it follows that, if the intervening resting periods of a tissue be continuously diminished, there will be a continuously increasing residual strain, and this might be detected by the consequent continuous decrease of conductivity and motile excitability. I have been able to verify this deduction by an experiment on a leaf of *Biophytum*, the details of which will be found in Chapter XX.

It will there be seen that, as the resting period was gradually shortened to half a minute, the conductivity underwent diminution from the normal 1.88 mm. to 1.54 mm. per second, that is to say, by 18 per cent. The reduction of motile excitability was found, however, to be still more marked, the height of response being reduced from the normal thirty-four to one division, that is to say, by as much as 97 per cent. On still further reducing the period of rest, from half a minute to ten seconds, it was found that there was no motile response whatever. The tissue is thus seen to be altogether incapable of response during a certain refractory period. The time-value of this refractory period not only differs in different plants, but also varies with the physiological condition. In *Biophytum*, normally speaking, it is ten seconds, and in *Mimosa* about one minute.

Earlier abolition of motile excitability than of conductivity.—We have seen in the last experiment, that while the conductivity of the petiole was reduced by 18 per cent. the motile excitability of the attached leaflet underwent a diminution of 97 per cent. This shows that motile excitability disappears earlier than conductivity. The reason will be apparent if we consider the difference between the two expressions of protoplasmic excitation. We have, in the conduction of the state of excitation from point to point, a direct expression of the transmission of the molecular change initiated by stimulus. The motile response, however, is a somewhat remote consequence of the series of events which follows on the fundamental molecular change. Intermediate occurrences are the permeability variation and the contraction, in this case differential, which it produces. The movement of the leaf is a result of all of these, and depends for its complete fulfilment on certain favourable circumstances. In any case, there are mechanical obstacles which have to be overcome in forcing the expelled water through channels of escape. That this must involve some degree of waste of force is partly seen in the fact that all excitations do not produce response, it being necessary that the stimulus should

exceed a certain minimum value in order to produce any movement at all. If, again, the escape of water should be resisted, owing to the peculiar condition of the tissue, which has already been described (p. 49), then even a strong stimulus would be unable to bring about movement.

Analysis of the different phases in the response of *Mimosa* under continuous stimulation.—Having now considered in detail some of those changes of protoplasmic properties which are brought about by the action of stimulus, we are enabled to study the effect of long-continued stimulation

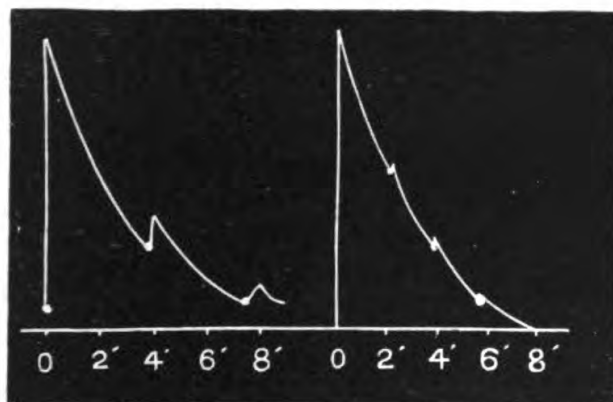

FIG. 60. Ineffectiveness of Stimuli, owing to Increasing Fatigue, in *Mimosa*

In the left-hand figure stimuli were applied at intervals of 3.5 minutes. These evoked feeble responses. In the right-hand figure stimuli were applied at intervals of two minutes. Response now became inconspicuous. Where stimuli were applied at intervals of one minute no effect was produced. The leaf was refractory.

from a somewhat different point of view. We saw that with incomplete recovery, protoplasmic excitability was progressively diminished. In order to demonstrate this, in the case of *Mimosa*, I obtained responses at intervals of 3.5 minutes, the uniform stimulus of condenser discharge being employed. The responses, which had been uniform, when stimulus was applied after complete recovery, at intervals of about eight minutes, were now found to be very much reduced (fig. 60). In a second series of experiments on the same specimen, the intervening periods of rest were still further

I

reduced, to two minutes ; and it will be noticed that, owing to increasing incompleteness of recovery, the responses were here reduced to the merest indications of twitches. When the intervening periods were still further shortened to less than one minute, the stimuli fell within the refractory period of the tissue, and produced no indication whatsoever of their effect. As an extreme instance, we have the effect of continuous stimulation, already described on p. 109. To be precise, we must remember that in this gradual abolition of response, under quickening stimulation, we not only see the action of diminished excitability, but also of diminished conductivity.

The erection of the leaf of *Mimosa*, by the relaxing action of fatigue, may also be assisted by the later contraction of the upper half of the pulvinus. For we have seen that in an anisotropic organ, the less excitable half responds subsequently to the more excitable. The contraction of the upper half of the pulvinus in *Mimosa* would produce erection of the leaf, and that this might sometimes happen appears probable from the fact that in the erection of the leaf under continuous stimulation it is occasionally found to be lifted above its normal position.

SUMMARY

Stimulus, by causing molecular derangement, brings about mechanical response ; and by molecular transmission of disturbance from point to point, the excitation is conducted to a distance. Excitatory mechanical response and conduction of excitation are different expressions of the effect of stimulus

After a period of rest from the action of stimulus, there is a restoration of molecular equilibrium. The protoplasmic properties of excitability and conductivity are then completely restored. Under such normal conditions responses are uniform.

A tissue in a sluggish condition has its molecular mobility increased by the action of successive stimuli. This produces the 'staircase' effect, of gradually enhanced responses.

When sufficient time is not allowed, there is a residual

molecular strain. The conductivity and excitability of an organ are thus diminished, and the responses undergo diminution, in consequence of cumulative residual strain.

Fatigue is greater in a motile than in a conducting organ. Motile excitability disappears earlier than conductivity.

The anomalous erection of the *Mimosa* leaf is brought about by the combined effects of diminution of conductivity, abolition of excitability, and possibly, in some instances, by the subsequent excitation of the upper half of the pulvinus also.

CHAPTER X

THEORIES CONCERNING DIFFERENT TYPES OF RESPONSE

The chemical theory of response—Insufficiency of the theory of assimilation and dissimilation to explain fatigue and staircase effects—Similar responsive effects seen in inorganic substances—Molecular theory—When molecular recovery is complete, responses uniform : when incomplete, fatigue brought about by residual strain—Fatigue under continuous stimulation, in inorganic substance, in plant, and in muscle—Staircase effect brought about by increased molecular mobility : examples seen in inorganic substance, and in living tissues—No sharp line of demarcation in the borderland between physical and chemical phenomena—Molecular changes attended by changes of chemical activity—Unequal molecular strain gives rise to a secondary series of chemical actions—Volta-chemical effect and by-products—Supposition that response always disproportionately larger than stimulus, not justified—Existence of three types : (1) response proportionate to stimulus ; (2) response disproportionately greater than stimulus ; (3) response disproportionately less than stimulus—Instances of stimulus partially held latent : staircase and additive effects ; multiple response ; renewed growth.

It has already been shown, in previous chapters, that the various types of response met with in animal tissues are exactly paralleled, even in detail, in the response of plants ; and numerous further instances of this fact will be met with in the course of the present work. It would thus appear that the theoretical explanation of either class of responses must be applicable to the other also. Existing theories regarding animal response, however, have not yet been found sufficient to meet all the difficulties of the case, and it is probable that the larger data now made available by the inclusion of response in plants, may go far to throw light on certain obscurities which are at present regarded as perplexing.

Chemical theory of assimilation and dissimilation.—The theory which is generally accepted at present may be referred to briefly as chemical. According to it, living matter

is maintained in a state of equilibrium by the two opposed chemical processes of building up or assimilation, and break-down or dissimilation. Stimulus causes a down or dissimilatory change, which is again compensated, during recovery, by the building up, or assimilative change. In the case of uniform responses, the two processes exactly balance each other. But on occasions when the down change is the greater of the two, the potential energy of the system falls below par, for the building-up process cannot then sufficiently repair the chemical depreciation caused by the downward change. Hence occurs diminution of response, or fatigue, which is supposed to be further accentuated by the production and accumulation of deleterious 'fatigue-stuffs.' The disappearance of fatigue, after a period of rest, is explained by the renovating action of the blood supply, which is also regarded as the means of carrying away the fatigue-stuffs.

A serious objection to these explanations, however, lies in the fact that even excised and bloodless muscles exhibit recovery from fatigue, after a period of rest. In isolated vegetable tissues, again, where there is no active circulation of renovating material, the same effect, and its removal after a period of rest, are observed.

Thus the difficulties met with in explaining fatigue according to a purely chemical theory are great enough. But still greater are those which we encounter when we come to deal with the staircase effect—typically shown in cardiac muscle—in which successive responses to uniform stimuli exhibit a gradual enhancement of amplitude. Here the result obtained is in direct opposition to the theory described; for in this particular case, we have to assume that the same stimulus which is usually supposed to cause a chemical break-down becomes efficient to produce an effect exactly the reverse. It is true that the heart, usually speaking, is charged with blood; but this particular staircase increment of response, under uniform stimulation, is observed even in the initial twitches of bloodless muscle (fig. 64), and here there can be no question of a supply of renovating blood.

Parallel types of response in living organic, and in inorganic matter.—Such being the difficulties involved in the explanation of a single class of phenomena, on the chemical hypothesis of assimilation and dissimilation, it may be well next to turn our attention to the conclusions suggested by the observation of response in matter generally. And for this purpose it is best to take the responses obtained from inorganic matter in particular, the hypothetical assimilation and dissimilation being in that case out of the question. With regard to the mode of observation, I have already explained how the molecular derangement consequent on stimulus may be studied, either (1) by recording the change of form ; or (2) by recording the variation of conductivity ; or (3) by recording the electromotive variation.

As an example in the first place of responsive contraction in inorganic matter, we may select for our investigation the response of india-rubber, under thermal stimulation. In this case, chemical changes, either up or down, are impossible. The second, or conductivity variation method, may be used in the case of metallic powders, the stimulus being that of Hertzian radiation. In this case also chemical action may be excluded, the experimental material being usually placed in naphtha. In the third case, again, where response is obtained by means of the electromotive variation, under mechanical stimulus, the substance used is platinum, the most chemically inactive of metals, electrolytic contacts being made by water.¹ The possibility of chemical action is thus reduced to a minimum, and the assimilatory change entirely excluded.

It will be found, however, that in all these cases of inorganic response, in which substances, physically and chemically widely unlike, are subjected to diverse forms of stimulation, and have their responses tested and recorded by absolutely different methods, the results obtained are exactly parallel. All alike, when sufficient intervening periods of rest are

¹ For details of these investigations and results, see Bose, *Response in the Living and Non-Living*.

allowed, give uniform responses to uniform stimuli. And when the period of rest is shortened, all alike exhibit fatigue.

From the conditions of experiment it is clear that these effects are physical or molecular. The molecular derangement caused by stimulus is thus gauged by the amplitude of response. Recovery is brought about by the restoration of molecular equilibrium, and for this purpose it has now become evident that the process of assimilation is not essential. When sufficient time, however, is not allowed for recovery, we have a residual molecular strain, and a substance in this strained condition is less responsive, as seen in the diminished height of its response. Fatigue is thus due to molecular strain, and its cumulative effects. But when the fatigued substance is allowed sufficient time for the strain to disappear, its subsequent responses exhibit the normal amplitude.

It was explained in the last chapter that in the case of *Mimosa*, as in that of muscle, a complete reversal of response is brought about by extreme fatigue, under continuous stimulation.

The following record shows a similar reversal in Arsenic, under the continuous stimulation of electric radiation (fig. 61). It was only after a sufficient interval of rest that this substance gave renewed normal response. It may be added that these fatigue-reversals, as in the longitudinal response of the *Uriclis Lily*, are sometimes found to be recurrent.

This curve of fatigue-reversal in Arsenic under continuous stimulation was obtained by recording the changes of electric conductivity in the substance. A still more striking analogy with the mechanical records of fatigue in plants and animals is afforded, however, by the automatic record given in fig. 62 of contractile responses in india-rubber. When this substance is excited by rapidly succeeding thermal shocks, we obtain

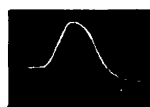

FIG. 61. Fatigue-Reversal in Arsenic, under Continuous Stimulation of Hertzian Radiation.

The horizontal line represents the duration of stimulation. Curve obtained by conductivity variation method.

first, the normal contractile effect, and secondly, the relaxation due to fatigue, in a manner exactly similar to that which characterises the fatigue-reversals of *Mimosa* and of skeletal muscles. In the present case, the india-rubber attained its maximum contraction in the course of two minutes, after which there was a continuous relaxation.

In this response of india-rubber, and in its fatigue-reversal, we have an analogy with the response of living animal tissues,

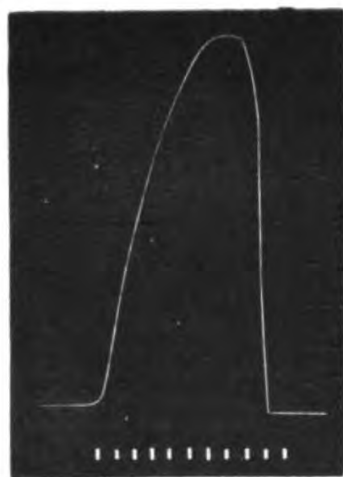

FIG. 62. Automatic Record of Fatigue in the Contractile Response of India-rubber under Rapidly Succeeding Thermal Shocks

The first effect of stimulus is contraction, but this passes into relaxation under continued stimulation. The time-marks represent intervals of half a minute.

such as muscle, so close as to compel us to the conclusion that both alike are phenomena of molecular response. A mere contraction of the india-rubber might have been supposed to be due to the specific action of heat on that substance. And had this been all, successive thermal shocks would have had the effect of continuously increasing the contraction, till a limit was reached. But if, on the other hand, molecular excitability be a factor in the process of response, we might then expect, under certain conditions of fatigue, a loss of molecular excitability. That

this is actually the case is shown by the fatigue-reversal, attended with relaxation, which is seen in the figure.

A muscle, again, in this condition of fatigue-relaxation, after a period of rest—during which the molecules have time for recovery from their state of strain—becomes once more excitable without any visible change. We found a like phenomenon occurring in the case of fatigued and relaxed *Mimosa*, under continuous stimulation. In that case it was, as we saw, a period of rest of about eight or ten

minutes, which made the fatigued *Mimosa* once more contractile. Returning to india-rubber, we find that here also a period of rest of ten minutes enables it to recover its excitability, and once more exhibit its responsive contraction.

From these facts it would appear that in order to explain the phenomenon of response, and its various modifications by fatigue and other factors, we have no option but to regard it as an expression of the molecular responsiveness of matter in general.

We next turn to the converse phenomenon of staircase response. Since response is an expression of molecular

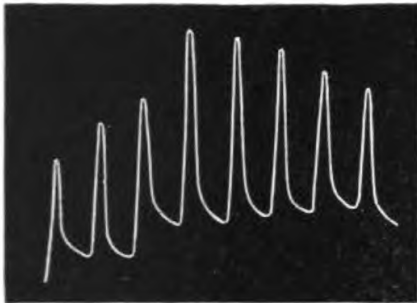

FIG. 63. Preliminary Staircase Increase, followed by Fatigue, in the Response of *Galena* to Hertzian Radiation
(Conductivity variation method)



FIG. 64. Preliminary Staircase Increase, followed by Fatigue, in the Response of Style of *Eucharis*

derangement, it follows that its extent will, other things being equal, depend on the degree of molecular mobility. This being so, it is conceivable that a substance, at first in a sluggish condition, may, by the impact of successive stimuli, have its molecular mobility gradually increased, with a corresponding enhancement of its response. In fig. 63 we have an example of this staircase effect, in the responses of *Galena*. It is to be noticed that this effect occurs at the beginning of the series of responses, as we should expect. After the attainment of maximum mobility, the phenomenon of overstrain is seen, with its accompanying diminution of response, or fatigue. I have obtained similar results in the longitudinal

response of plants (fig. 64). It need only be mentioned, further, that exactly the same preliminary staircase effect, reaching a maximum, and followed by fatigue, is found in the responses of muscle (fig. 65).

The inference that the occurrence of the staircase effect is due to the gradual removal of molecular sluggishness, receives further support from the following experiment on a plant where sluggishness is brought on artificially, and made to disappear gradually. Sluggishness may be induced in a tissue by cooling, this condition being made to disappear, by the gradual return of the substance to the ordinary temperature of the room. On carrying out such an experiment,

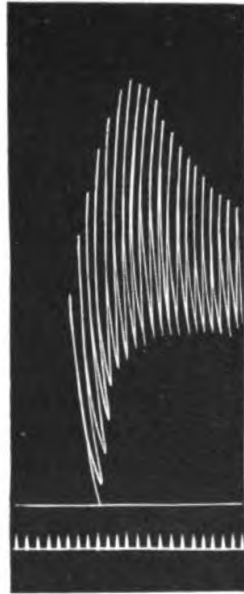

FIG. 65. Preliminary Staircase, followed by Fatigue, in the Responses of Muscle (Brodie)

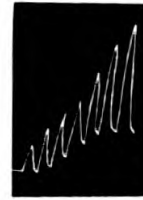

FIG. 66. Staircase Increase in Electrical Response of Petiole of *Bryophyllum*, rendered sluggish by cooling

and recording the successive electrical responses to successive uniform stimuli, I obtained, as I had expected, a marked staircase effect (fig. 66).

Merging of physical into chemical phenomena.—

I have explained that responsive phenomena are primarily due to the molecular distortion caused by stimulus, that is to say, they are of a physical character. Fatigue has also been shown to be primarily due to residual strain. But it must be borne in mind that in the borderland between physics and chemistry there is no sharp line of demarcation. For example, yellow phosphorus under the stimulus of light is

converted into the molecular red, or allotropic variety. This molecular change, however, is also attended by a concomitant change in the chemical activity, phosphorus in the red condition being less active chemically than in the yellow.

Under certain circumstances, further, it is possible to have a secondary series of chemical events following upon a condition of unequal molecular strain. We have seen that a homogeneous living tissue, when unstimulated, is iso-electric. When stimulated, however, an electromotive difference is induced, as between the more and the less acted parts of the tissue. The result is an electrical current attended by chemical changes. As a consequence of such volta-chemical action, when prolonged, by-products (fatigue-stuffs?) may be accumulated, and these may have a depressing effect on the activity of the tissue. Hence, just as after very prolonged activity of a voltaic element it is necessary to renew the active element and change the electrolyte surcharged with by-products, so, after sustained activity of a living tissue, the process of renewal, or renovation, will be necessary. Thus we see how, upon the fundamental molecular derangement, a chain of very various chemical events may follow as its after-effect. And it is only by going in this way to the very root of the phenomenon, that we can avoid the many contradictions with which we are confronted by the chemical theory.

I have therefore aimed at demonstrating the universal existence in matter of the property of responsiveness, and by taking the simplest cases and excluding as many complicating factors as possible, have attempted to show further how this power of response is modified by those conditions which occasion fatigue, or its converse, the staircase effect. Having thus cleared the ground, it is possible to take up cases of greater complexity.

Different modes of transformation of stimulus.—It has been assumed that response is brought about by a sudden explosive chemical change, the stimulus acting as if on a trigger, for the release and run-down of potential chemical

energy. This implies that response is disproportionately greater than stimulus, and that the responsive change is attended by an evolution of heat and chemical by-products. It would follow, however, from such rapid depreciation, that fatigue must be the invariable consequence of any series of responses. But it is notorious that in the responses of nerve, not only is there no fatigue, but neither is there any evolution of heat, nor occurrence of chemical change, that can be detected.

As the simplest case, we have hitherto considered the substance acted on to be neutral in its character, that is to say, not active in the sense of being able to absorb stimulus and hold it latent. But if we regard the living organism as a machine, three different cases are conceivable. These are : first, that in which the responding substance simply converts the energy received as stimulus into response ; secondly, that in which the responding substance possesses a large amount of energy, some of which is set free by the action of the stimulus ; and lastly, that in which the responding substance is capable of absorbing and holding latent, to a greater or less extent, the stimulus which it receives.

(1) *Response proportionate to stimulus.*—The first of these types may be illustrated by a responding circuit which contains a magnetic motor—say a galvanometer—translating current into motion. The source of stimulus may be an external battery periodically closed by a tapping key. The waste of energy by the production of heat may be supposed to be brought down to a minimum in this circuit by using a feeble current and reducing the resistance. Uniform stimuli will now cause uniform responses of the responder. Response will be proportionate to stimulus, and there will be no chemical, and no appreciable thermal, change in the responder. This is a state of things which may be said to approximate closely to the responsive peculiarities of the nerve.

(2) *Response disproportionately greater than stimulus : responding substance reduced below par.*—As an example of the second type, we have to imagine a responding system which

contains a large amount of energy. We may suppose it to consist of a storage battery and a galvanometer, the circuit being normally incomplete. External stimulus may, by some easily arranged mechanism, close the responding circuit periodically. In this case, the responses might be made disproportionately larger than the stimulus. There will then be a progressive run-down of the latent energy of the system, and the responses will show diminution, or true fatigue. The system, at the end of the experiment, will be found to be below par. This case may be paralleled by that of highly excitable tissue which is wasted under excessive and long-continued stimulation.

(3) *Stimulus wholly or partially absorbed.*—The third type of substance we have supposed to be one which is capable of absorbing and holding latent, to a greater or less extent, the stimulus which it receives, and under this we may have several important sub-cases.

(a) *Staircase and additive effects.*—The absorbed stimulus may gradually enhance the molecular mobility, with gradual enhancement of response. This is seen exemplified in the staircase effect. Another example of the same thing is probably to be found in the singly ineffective stimulus which becomes effective on repetition. Evidently in this case, the energy of the first few stimuli is held latent in the tissue and added up until it reaches the threshold of response.

(b) *Multiple response.*—We can next see the possibility of a very interesting case of stimulus becoming latent. A spring which is immersed in a viscid fluid may, on receiving a feeble blow, give a single vibrational response. But if the blow be powerful, this single strong stimulus will give rise to a multiple series of vibrational responses. Again, a phosphorescent substance acted on by light absorbs it, and, on the cessation of incident stimulus, continues to give up the excess of latent energy thus acquired in the form of luminous vibration. A selenium cell again, when acted on by a single strong flash of light, I have found to give what may be regarded as two responses, one strong and the other feeble.

From certain metallic particles, again, when exposed to a single strong flash of electric radiation, I have obtained pulsatory responses. From the consideration of all these cases, I was led to investigate the question whether a plant-tissue, when acted on by a single strong stimulus, could be found to give similar repeated responses. From this I was led to the discovery of Multiple Response in plants, a phenomenon which I find to be very prevalent, and which I shall describe fully in Chapter XX.

(c) *Response disproportionately less than stimulus: responding substance raised above par.*—It is the last of these sub-cases, however, which we could least easily have foreseen. It is as if here the active expression of the incident stimulus were bifurcated. Returning once more to the mechanical model, we may imagine the responding portion of the system to contain, besides the mechanically responding galvanometer, two plates of lead, immersed in dilute sulphuric acid, by which the energy of the stimulating current is partially stored up. The external stimulating current has now to do two things, first, to cause mechanical response in the galvanometer, and secondly, to store up an increasing amount of latent energy in the second part of the responding system. It is evident here that, owing to increasing storage, the mechanical response of the galvanometer may become progressively less. We are, perhaps, too apt to ascribe to 'fatigue' all cases of diminution of responses. For in this case we shall have an appearance of fatigue which is not due to the run-down of energy, but to its actual increase, in the responding system.

I have been able to discover a parallel case to this in the response of plants, a case, that is to say, in which the response is disproportionately smaller than stimulus, successive stimuli nevertheless causing an increase of the energy of the system. I took for my experiment a straight tendril of *Passiflora* in which growth had undergone arrest. It may be pointed out here that a certain tonic condition is necessary to the continuation of growth. This tonic condition is determined, as

will be shown later, by the sum total of energy latent in the tissue. From the curve of response given in fig. 67, it will be seen that at the beginning of the experiment, the length of the tendril being constant, the first part of the record was horizontal, instead of descending, as would have been the case had the tendril been growing. The contractile shortening brought about by stimulus is here represented upwards. The stimulus of induction shock was now applied at intervals of one minute, and the record shows that the recovery, instead of stopping short at the level of the horizontal line, has proceeded beneath, thus indicating that stimulus has been effective not only in producing contractile response, but also in afterwards initiating growth! (Cf. fig. 178.)

And further, as the stimulus goes on causing not only mechanical response, but also accelerated growth, we see that the successive mechanical responses are undergoing diminution. The application of stimulus ceased at the end of the fourth response, and we observe active growth proceeding from this point as a result of the energy absorbed from the previous stimuli. We have thus demonstrated the very curious case in which the building up process is attended by an actual diminution of response, and where, after stimulation, the energy of the responding organ, instead of being reduced, is raised above par. This experiment explains why an athlete in constant practice does not waste away, but actually increases, muscle.

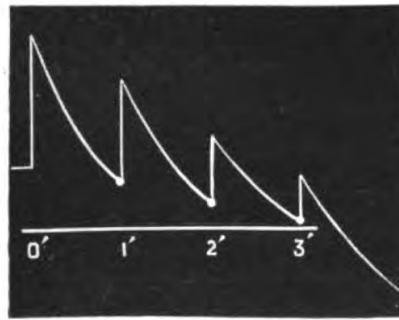

FIG. 67. Mechanical Response shown upwards in Tendril of *Passiflora* in which Growth was originally at Standstill

Stimulation, besides producing mechanical response, initiated the opposite movement of growth, as shown by the slope of the base-line downwards.

SUMMARY

The principal types of response seen in animal tissues are found also in the responses of plants and of inorganic substances.

Three types of responses are possible : (1) that in which response is proportionate to stimulus ; (2) that in which response is disproportionately greater than stimulus ; and (3) that in which all or part of the stimulus is, for a longer or shorter time, absorbed by the tissue and held latent.

The subsequent effect of stimulus which is held latent may sometimes be seen in singly ineffective stimulus which becomes effective on repetition ; or in the staircase response, consequent on the enhancing of molecular mobility by the partial absorption of previous stimulus.

The fact that stimulus may be held latent for a time, and subsequently find expression, is strikingly shown in the occurrence of multiple response, in answer to a single strong stimulus.

It is also possible for the incident stimulus to become divided in its expression, part of it finding an outlet directly in mechanical response, and part becoming latent, and causing accelerated growth. The gradual augmentation of the latter of these may cause a corresponding diminution of the former. An appearance of fatigue is thus brought about, which is misleading, as the decrease of mechanical response is in this case due, not to a diminution, but to an increase of latent energy in the responding substance, as shown by its capacity for renewed growth.

CHAPTER XI

EFFECT OF ANÆSTHETICS, POISONS AND OTHER CHEMICAL REAGENTS ON LONGITUDINAL RESPONSE

Response modified by physiological change—Carbonic acid causes depression, and transitory exaltation as after-effect—Gradual abolition of response in hydrogen and restoration by access of air—Chemical agents cause contraction or relaxation of plant-tissue—Effect of alcohol causing temporary exaltation of response followed by depression and protracted period of recovery—Ether causes relaxation and temporary depression of response—Explanation of anomalous action of ether on stimulated *Mimosa* leaf—Abolition of response by hydrochloric acid—Response restored by timely application of ammonia—Abolition of response by poisonous reagent—Similarity of effect of chemical agents on the response of animal and vegetable tissues.

THE subject of our inquiry, in this and succeeding chapters, will be the determination of those influences which bring about the variation of conductivity and excitability in plant-tissues. The variation of excitability induced in a tissue by chemical reagents, may be studied through the consequent modifications of the responses. Various forms of response which may be used for this investigation are (1) electrical, (2) autonomous, (3) growth, and (4) the simple mechanical response about to be described. A description of the modifications induced in electrical response under the action of chemical reagents will be found on pp. 73–80 of my book, 'Response in the Living and Non-Living.' The effects of chemical reagents on autonomous pulsation and on growth are given in detail in Chapters XXV, XXVII, and XXXV of the present work. But it may be said here, that the results obtained by all these different methods are concordant, and that the simple method of mechanical response now to be detailed is to be regarded as an additional corroboration. It should also be borne in mind that the

K

effects of chemical reagents are subject to modification, as is fully explained later (pp. 322 and 477), by the tonic condition of the specimen.

The method of procedure consists in first obtaining a series of responses to uniform stimuli under normal conditions, and then a similar series after the application of the reagent. The uniform individual stimuli in both series are applied at intervals which allow of complete recovery. The intensity of stimulus, and the time-intervals, are kept constant throughout the experiment. The chemical agent may take the form of gas or vapour, or it may consist of a liquid. In the former case, by the turning of the three-way stop-cock described on p. 72, water-vapour is passed through the plant chamber, and the responses thus obtained are taken as the normal. By a quick manipulation of the stop-cock, the gaseous or vaporous reagent is next introduced, and the responses now obtained exhibit the physiological modification induced by it. The effect produced by some agents is permanent, by others transitory. This difference may be demonstrated by turning the three-way cock once more, so as to allow water-vapour to replace the specific gaseous medium. The responses now obtained exhibit the after-effect.

The difficulty in this investigation lies in the selection of specimens which exhibit complete recovery, together with uniformity of successive responses. For this purpose we may take any radial organ, one of the most excitable, and therefore suitable, of these being the filament of the corona of *Passiflora*. In this case high magnification is not necessary, and very moderate stimulus is sufficient. Failing *Passiflora*, I have frequently used with success the staminal filaments of the *Uriclis* Lily, and *Brownea ariza*, and the styles of *Datura* and *Eucharis* Lily. It should be borne in mind that the excitability of the tissue is to a certain extent influenced by seasonal conditions, being different under different circumstances of time and weather.

It is best to choose specimens from flowers which are already open, and in which growth has just ceased. Although,

as already stated, this is not the most excitable period for the tissue, yet it affords us the advantage of simplified conditions, inasmuch as, owing to cessation of growth, the line of record before stimulation, or the base-line, now remains horizontal. Stimulation, producing contraction, is represented by up movements of response, and the recovery brings the curve back to the base-line.

Effect of carbonic acid gas.—I shall now proceed to describe a few typical experiments, on the modification of response by chemical reagents, out of a large number, which were performed on the radial organs of plants of various kinds, in the course of the season. And first we shall take the effect of carbonic acid.

The effect of this gas, after the lapse of about half an hour, is one of considerable depression. By this time the responses are reduced to about half their normal value, and this depression, though slow, is continuous. This may be looked for as the general effect, after a certain length of time, of the action of carbonic acid

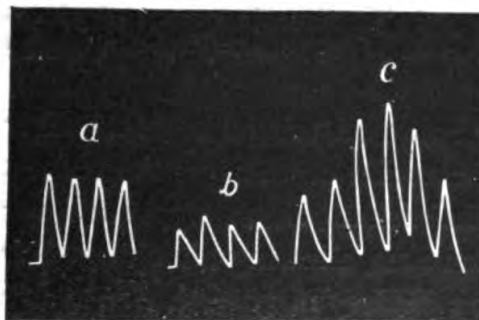

FIG. 68. Effect of Carbonic Acid Gas on Longitudinal Contractile Response

(a) Normal response; (b) after exposure to carbonic acid; (c) transient exaltation after readmission of air.

gas. The immediate result of the sudden introduction of an abnormal factor may, however, be slightly different in different cases, according to the tonic condition of the tissue. This immediate effect is sometimes one of brief depression followed by equally brief exaltation, to be succeeded by the true depression. Or there may be a short exaltation, followed by the true depression. The restoration of the normal condition, however, is generally followed in the case of carbonic acid gas by a gradually increasing exaltation of the response, which may culminate in double its ordinary height, and after this it again attains the normal (fig. 68).

Effect of hydrogen gas.—We next investigate the

K 2

effect of hydrogen gas. The characteristic effect of depression occurs in this case after a much longer interval than is required by carbonic acid. The immediate result of application is very erratic and various. There may sometimes be an exaltation, or even the contrary, a reversal, of

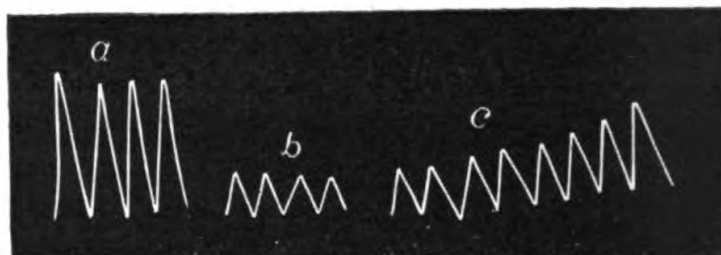

FIG. 69. Effect of Hydrogen Gas .

(a) Normal response ; (b) after twelve hours' exposure to H. ;
(c) slow revival of response after readmission of air.

the normal response. But after a twelve hours' exposure to the action of this gas the responses of the tissue are so much diminished as to approach very near abolition. On now, however, allowing air charged with water-vapour to displace the hydrogen gas, the responses undergo a steady revival (fig. 69). There is here no sudden exaltation, such as is the general after-effect of carbonic acid gas.

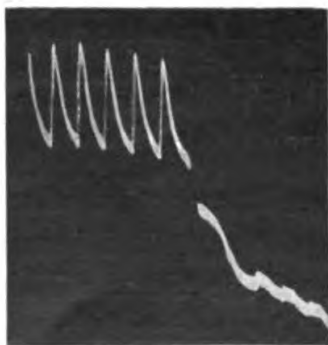

FIG. 70. Photographic Record showing Effect of Carbon Disulphide in Abolishing Response

Normal response, seen to left, abolished by introduction of vapour of CS_2 .

with greater rapidity. Such an agent may be found in the vapour of carbon disulphide (fig. 70).

Effect of carbon disulphide.—

We have seen that the depressing effect of hydrogen takes place very slowly. This is owing to the fact that this gas acts here rather as an agent for cutting off that supply of oxygen that is necessary to the maintenance of the normal life of the plant, than as a direct poison. But we have other gases which are actively toxic, and in such cases the diminution or abolition of response takes place

I may here draw attention to the great advantage offered by the study of the variation of longitudinal response, in determining the nature of the action of various chemical agents. The modifications which these agents produce in the lateral response of the pulvini of sensitive plants are not so simple, inasmuch as we have to deal in these cases with differential action. In radial organs, on the other hand, the response-record gives us indications of the specific action of each modifying agent. In the response itself there are, it must be remembered, two factors which have to be distinguished, namely, contraction in response to stimulus, and the power of recovery from contraction, or relaxation. The diminution and final abolition of response may be brought about, then, in two different ways. The effect of a given agent may be to diminish the normal relaxation which brings on recovery. Successive stimuli will in that case produce a cumulative residual contraction, which places the tissue in a state of strain, in consequence of which subsequent responses become enfeebled. We may, on the other hand, have an agent whose effect is to produce abnormal relaxation. The contractile impulse due to stimulus is in this case opposed by the abnormal relaxation induced by the agent, and we have, in this case also, an enfeeblement and abolition of response.

The comparison of the time-relations of the normal and modified curves, together with the trend of the base-line up or down, will show the nature of the reaction, in an unmistakable manner. All these facts are clearly demonstrated in the experiments and curves given below.

Effect of alcohol.—I shall next describe the action of the vapour of alcohol. Generally speaking, the immediate effect in this case is one of exaltation, though individual idiosyncrasies may sometimes be present, which cause depression from the very beginning. The general effect of this reagent, however, appears to be a prolongation of the period of recovery. So what is gained by brief exaltation is lost again by induced sluggishness. Thus, from the result

recorded on a fast-moving drum, using the style of *Datura alba*, I find that the height of the normal response was eleven divisions, and complete recovery took place in one minute and a quarter. During the first period of exaltation, after the application of alcohol, the height of the response was increased to sixteen divisions, that is, practically half as much again. But the period of recovery was protracted to four and a half minutes, or nearly three times the period of normal recovery. These considerations will fully explain the series of responses under the continued action of alcohol-vapour, given in fig. 71, where (a) shows normal response, (b) the immediate and transitory exaltation, and (c)—which

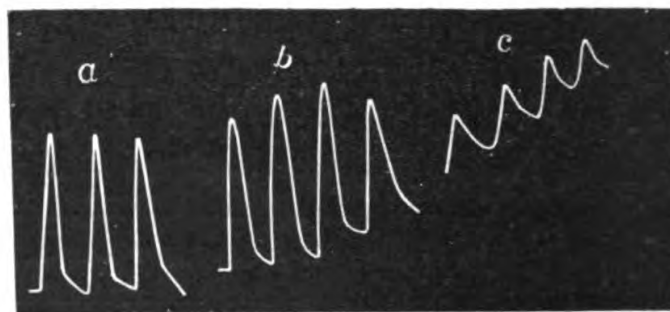

FIG. 71. Effect of Vapour of Alcohol
(a) Normal response ; (b) immediate temporary exaltation on introduction of alcohol ; (c) subsequent depression.

was taken after fifteen minutes' further application—the diminished responses in which the contraction remainders are a marked feature. On blowing off the alcohol-vapour, however, and substituting fresh air, the tissue is found to recover slowly its normal excitability. If, instead of alcohol-vapour, dilute alcoholic solution be applied, the depressing effect is immediate and very great.

Effect of ether.—We now pass on to the question of the action of the anæsthetic agent, ether. This produces a relaxation so great as to be incapable of proper representations within the limits of the diagram (fig. 72), where it is merely indicated by the dotted line. It is to be remembered that contraction is shown by lines upward, and recovery, or

relaxation, by lines downward. Owing to the predominance of this relaxing tendency, it will be seen that true contractile movement is here very much diminished. Even after the relaxation has attained its maximum, the responses remain insignificant. When the specimen is not too long etherised, the blowing in of fresh air brings on gradual restoration. It may be mentioned here that ether also produces relaxation of animal tissue.

Explanation of anomalous effect of ether on Mimosa.—

This experiment on the effect of ether affords a very satisfactory explanation of a phenomenon in the recovery of *Mimosa*, which has hitherto been regarded as anomalous. The outspread position of the leaflets is generally regarded as one of sensitiveness; but, when they have just closed, in consequence of stimulation, if they be subjected to ether-vapour, they open out. Though now, however, mimicking the appearance of sensitiveness, they are in fact over-relaxed, a condition which is one of relative insensitiveness. The explanation may be gathered from the record in fig. 72. It is necessary here to give specific meanings to certain terms which have been used somewhat indefinitely. We know that stimulation causes the fall of the leaf, by differential contraction, and that the organ recovers, or 'relaxes,' into its original form after a period of rest. This term 'relaxation,' then, may be properly used as the converse of 'contraction.' But, in consequence of the expulsion of water from the organ after stimulation, it becomes flaccid, and this condition also is sometimes vaguely described as 'relaxed.' In my own use of the word, however, I shall confine myself to denoting by it that process which is the

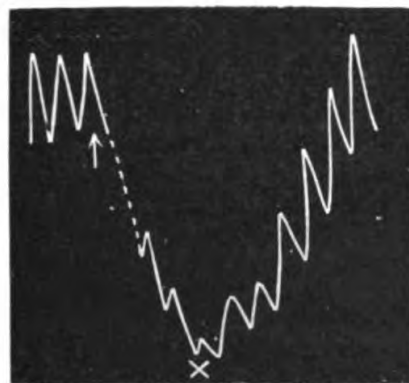

FIG. 72. Effect of Ether

Arrow marks moment of application. This produced relaxation and depression of response. Air substituted at x, and there is subsequent recovery of response.

opposite of contraction, and which therefore brings about a position contrary to that effected by stimulus.

We have seen that ether produces a relaxing effect which is more rapid than the process of relaxation that brings about recovery. And we have seen how, in consequence of this excessive relaxation, excitatory contraction is diminished or abolished. Hence, we see how a stimulated *Mimosa* leaflet under ether relaxes into an outspread position, which nevertheless is indicative of no renewed sensitiveness such as accompanies true recovery.

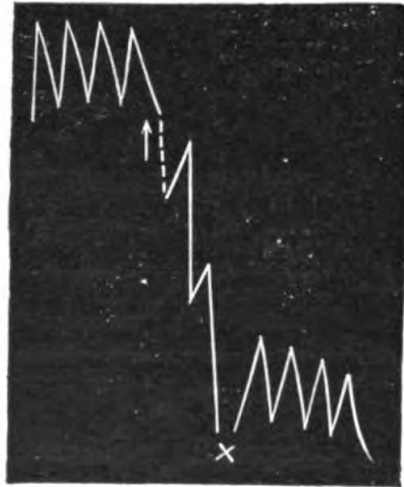

FIG. 73. Effect of HCl Vapour
Arrow indicates moment of application. Depressing effect neutralised by antagonistic action of NH_3 at x.

Effect of vapour of hydrochloric acid.—I shall now deal with the case of strongly poisonous agents, of which hydrochloric acid may be taken as typical. On passing the vapour of hydrochloric acid into the plant chamber there was produced a great relaxation, and the responses underwent a rapid diminution which ended in abolition. The effect of this poison is so persistent that the blowing-in of fresh air did

nothing to revive the response. But the timely application of vapour of ammonia is found to act as an antidote, restoring the response (fig. 73).

Effect of chlorine gas.—This gas also produces a marked depression of excitability, which, under long-continued action, brings about the permanent abolition of response. The accompanying photographic record (fig. 74) shows the effect very clearly. The normal responses to the left are seen to be very rapidly diminished after the application of this gas, the response being reduced to one-eighth of its original value in the course of nine minutes. There are other important considerations in connection with this question, of relaxation

or contraction as the direct effects of chemical agents, which it would be out of place to treat in detail here. It need only be stated that these effects, which can be very accurately and continuously recorded by the arrangement of the Optic Lever, are very suggestive. They are found to be modified by the tonic condition of the tissue, the strength of the agent, and the duration of application. Thus, an effect of relaxation may, after a time, pass into the opposite, of contraction. And since these relaxations or contractions of the tissue have a modifying influence on the response, much light on the obscure subject of the effect of drugs becomes possible through this study. I have been able already to obtain several curious and interesting results, of which I may here refer to one, in which two drugs, either of which when applied singly would abolish response, and produce death, are made, when applied in succession, to act as antidotes to each other. It is my intention to show in the course of this book that all the physiological phenomena of the animal have the closest correspondence with similar phenomena in the plant, and this being so, an investigation carried out on the lines indicated, with plants, is likely to be of very great importance, practically as well as theoretically.

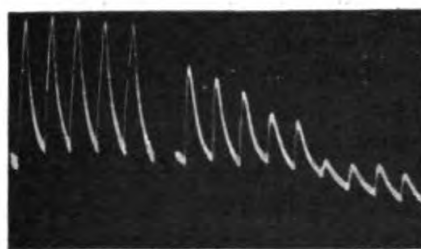

FIG. 74. Action of Chlorine
Photographic record, showing normal effect to the left, depressed and almost abolished after introduction of the gas.

SUMMARY

The responsive contractions of an organ afford a reliable indication of the excitability of the tissue.

The physiological changes induced in plant-tissues by the action of chemical reagents are outwardly manifested by modification of response.

Certain agents, producing great relaxation, reduce the

power of responsive contraction. Others produce the opposite effect, thus protracting the natural period of recovery.

Hydrogen gas produces a gradual diminution of response, which is restored to its original value on the readmission of air.

Carbonic acid causes depression, but the restoration to normal conditions is generally followed by temporary exaltation above the normal.

Vapour of alcohol causes gradual, and solution of alcohol rapid, depression. This action may be preceded by temporary exaltation. The recovery-period is very much protracted.

As in the animal, so also in the plant-tissue, ether causes marked relaxation. The depression of response increases progressively with the exposure; on blowing off the vapour, response is not only restored but may even show an exaltation. The opening of the *Mimosa* leaflets under ether is not indicative of true recovery but of over-relaxation.

A poisonous reagent, like hydrochloric acid or chlorine, permanently abolishes the response.

Reagents which individually abolish response may, by their antagonistic character, act as antidotes to one another.

CHAPTER XII

EFFECT OF TEMPERATURE

Temperatures optimum, maximum, and minimum—Diminution of electrical response by cooling—Temporary or permanent abolition of response due to cold—Characteristic differences exhibited by different species—Mechanical response of *Biophytum* and autonomous response of *Desmodium* arrested by cold—Prolongation of latent period—Diminution of longitudinal mechanical response by cold—Diminution of electrical response of plants by rise of temperature—Similar diminution seen in longitudinal mechanical response—Increase of excitability due to cyclic variation of temperature.

ONE of the factors which modify response in plants is temperature. It is known in a general way that certain temperatures are favourable, and others unfavourable, to physiological activity. It is generally understood further that there is a certain optimum, in the case of each species, above or below which the excitability of the plant undergoes diminution. After this, on reaching a certain maximum or minimum temperature, as the case may be, excitability is abolished, and if these unfavourable conditions be long maintained the plant is apt to be killed. But the problem of the precise determination of such points has hitherto offered insuperable difficulties.

Effects of cold : (a) *Diminution or abolition of electrical response.*—Already, however, by adopting the electrical mode of investigation, I had been able to overcome these difficulties ; for I had found that the amplitude of the electrical responses, under different temperature-conditions, afforded a means of measuring the excitability of a tissue at the respective points. And now, by the use of mechanical response, I am enabled again to investigate the same problem by new and independent means. From the results obtained it will be seen that

each method furnishes a remarkable corroboration of the other. I shall now proceed to describe these various results.

As an effect of low temperature I have found, by the use of the electrical method, that response undergoes a very great diminution. For example, the subjecting of a petiole of *Eucharis* Lily to a temperature of -2° C. almost abolished its excitability (fig. 75).

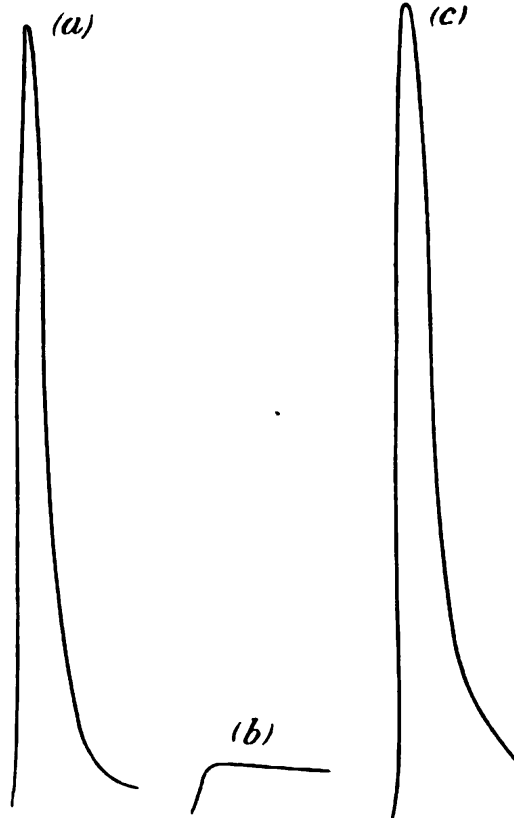

FIG. 75. Diminution of Response in *Eucharis* Lily by Lowering of Temperature

- (a) Normal response at 17° C.
 (b) The response almost disappears when plant is subjected to -2° C. for fifteen minutes.
 (c) Revival of response on warming to 20° C.

on being subsequently restored to its normal temperature, gives no sign of revival by response; whereas the hardier Holly and Ivy, when subjected to the same treatment, do exhibit signs of renewed life (fig. 76).

(b) *Prolongation of latent period, or abolition of lateral and autonomous responses.*—Turning now to mechanical

When the specimen, however, was restored to the normal temperature the original response reappeared, and sometimes with even greater amplitude than at first.

When the plant is maintained at a very low temperature for a considerable length of time, the normal electrical response disappears altogether, and the specimen undergoes permanent death. In this respect, different species of plants have characteristic powers of resistance. For example, the tropical plant, *Eucharis* Lily, after an exposure of twenty-four hours to a temperature of 0° C.,

response, I find in the case of the plant *Biophytum* that the effect of too great cold, or of long-continued exposure to low temperature, is the abolition of its lateral response. But when the temperature is, relatively speaking, only slightly lowered, induced sluggishness is shown in a very interesting manner. Whereas, at the normal temperature, say 23° C., the response of the leaflet of *Biophytum* takes place immediately, after moderate cooling, on the contrary, the latent

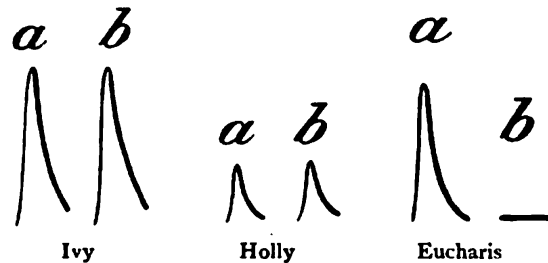

FIG. 76. After-effect of Cold on Ivy, Holly, and Eucharis
(a) Normal response ; (b) response after subjection to freezing temperature for twenty-four hours.

period is increased, and response does not begin to take place until from one to two seconds after the application of stimulus. Lowering of temperature also abolishes the autonomous response of *Desmodium*.

(c) *Diminution of longitudinal response.*—With regard to longitudinal response, I have been able to demonstrate the effect of cold, by taking a specimen of the coronal filament of *Passiflora*. The specimen was kept for fifteen minutes in ice, after which electrical stimulus was applied with no immediate contractile effect. Control specimens, on the other hand, exhibited considerable contraction. These contractions were measured in both cases by means of a micrometer. The specimens taken for experiment were all 21 mm. in length. The average contraction of the control specimens was 1.5 mm. The cooled specimen, as said before, exhibited no immediate response. But on continuing stimulation for two minutes, contraction began to take place slowly, reaching a maximum of only .5 mm. It must be borne in mind

that the specimen was all this time undergoing gradual warming by the temperature of the room.

Another way of demonstrating the effect of cold on the longitudinal response of this corona, is to take three filaments ; of these (*a*) has been subjected to cold, (*b*) is normal, and (*c*) has been killed by immersion in hot water at 60° C. The right-hand ends of the filaments are so arranged as to lie perfectly even, and a moist cotton thread touches these ends. A brass spring presses against the left-hand ends. The thread and the brass spring serve the purpose of two electrodes, by which shocks can be sent through the three specimens at the same time.

The right-hand end of the object, so arranged, is placed within the field of a microscope of low magnifying power which has a micrometer eye-piece. At the beginning the ends of the specimens lie in a straight line, but after the passage of a shock for a period of a few seconds it is found that, while the normal (*b*) shows the maximum contraction, the cooled (*a*) exhibits very little, and the killed (*c*) none at all.

The difficulty in conducting experiments on cooling, lies in the fact that the inertness due to cold is liable to disappear with more or less rapidity when the specimen, for experimental purposes, is exposed to the temperature of the room, which is about 23° C. It cannot be kept immersed in ice-cold water, as the exciting current will then to a great extent pass through the conducting water itself. The only practicable way, therefore, is to subject the specimen to prolonged cold, and make a rapid observation afterwards.

I next attempted to obtain a series of responses, when the temperature of the space in which the specimen was placed was very gradually lowered. As recovery from the stimulus of electrical shock constitutes a very prolonged process, I had to use thermal stimulation. But this introduced the difficulty of itself raising to a certain extent the temperature of the space. I had been fortunate enough, however, to secure a few specimens of the style of *Datura*

which were extremely sensitive to cold, and thus, notwithstanding the disadvantages incidental to the experiment, I was able to obtain the very interesting records shown below. The experiment was carried out as follows:

The specimen was mounted in the special plant chamber. By proper manipulation of the stop-cocks it was possible to send at will through the chamber, first, air at the ordinary temperature—under which conditions the normal responses were taken—and, secondly, air which had been cooled by ice, reducing the temperature of the chamber by several degrees. The responses then obtained showed the effect of cooling. And, lastly, ordinary air was re-introduced, and the responses at this temperature again recorded. Fig. 77 shows that while the amplitude of the normal responses was eight divisions, that of the responses at reduced temperature was only three, and that, on the restoration of normal conditions, the responses increased in a staircase manner tending to return to their original value.



FIG. 77. Effect of Cold on Longitudinal Response

(a) Normal response; (b) after cooling; (c) during gradual restoration to normal temperature.

Effect of rise of temperature: (a) *on electrical response.*—So much for the results of cooling; we have now to study the effect of rise of temperature. And, first, I shall refer to observations made by means of electric responses. It may be said that the optimum degree of temperature for the excitability of the plant must be understood to vary with different species. In several cases, however, I have found it to lie at about 22° C. But it must be premised that this optimum of response refers to passive tissues only, that is to say, to those in which there is no growth. The optimum temperature for growth may be different. In the ordinary response of passive tissues, heat has only to bring about a condition favourable to mobility. In the case of growing tissues, however, something addi-

tional has to be effected, namely, the acceleration of growth. We may therefore expect that the optimum temperature for growth will be relatively higher than that of simple response. And this I generally find to be the case. When the temperature is much raised, the electrical response of a plant is seen to undergo diminution (fig. 78). It is to be noted that the temperatures referred to are dry, or atmospheric only. This explains why, even when the temperature was raised to 65° C., which is above the fatal point, response was still

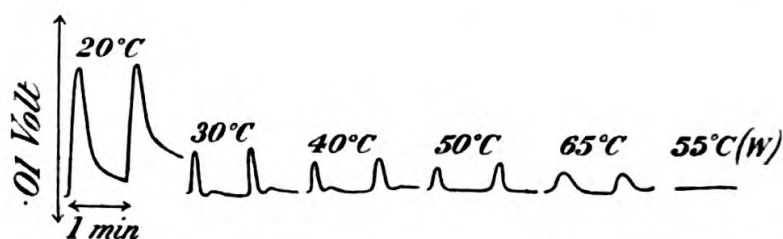

FIG. 78. Effect of Rise of Temperature on Electrical Response

observed. Owing to the relative non-conductivity of the plant, and the evaporation from its surface, the tissue does not actually attain the temperature of the surrounding air. When, however, it was subjected for some time to a water-temperature of 55° C. response disappeared, by the death of the specimen.

(b) *On longitudinal mechanical response.*—I give next (fig. 79) the effect of rise of temperature on longitudinal me-



FIG. 79. Effect of Rise of Temperature on Longitudinal Contractile Response of Plant

chanical response. The specimen was a filament of the corona of *Passiflora*, the stimulus used being thermal. In order to subject the plant to definite temperature conditions, the adjustments were made by means of a subsidiary heating coil, placed inside

the chamber. Any given temperature above the normal could thus be maintained constant, for the required length of time, by simple adjustment of the strength of the heating current. The results thus obtained in mechanical response

will be seen to be exactly parallel to those already given in electrical response.

The responses are seen to be very much diminished at 35° C., and almost to disappear at 55° C., which, as will be shown later, is near the death-point. Heat-rigor began to manifest itself a few degrees above this point, in the contracting of the specimen as a whole. This last phenomenon will be treated at greater length in a subsequent chapter. I have already alluded to the experiment in which, when the plant is killed by excessively high temperature, the response disappears altogether.

Effects of cyclic variation of temperature: (a) *on electrical response.*—I detected another very curious result

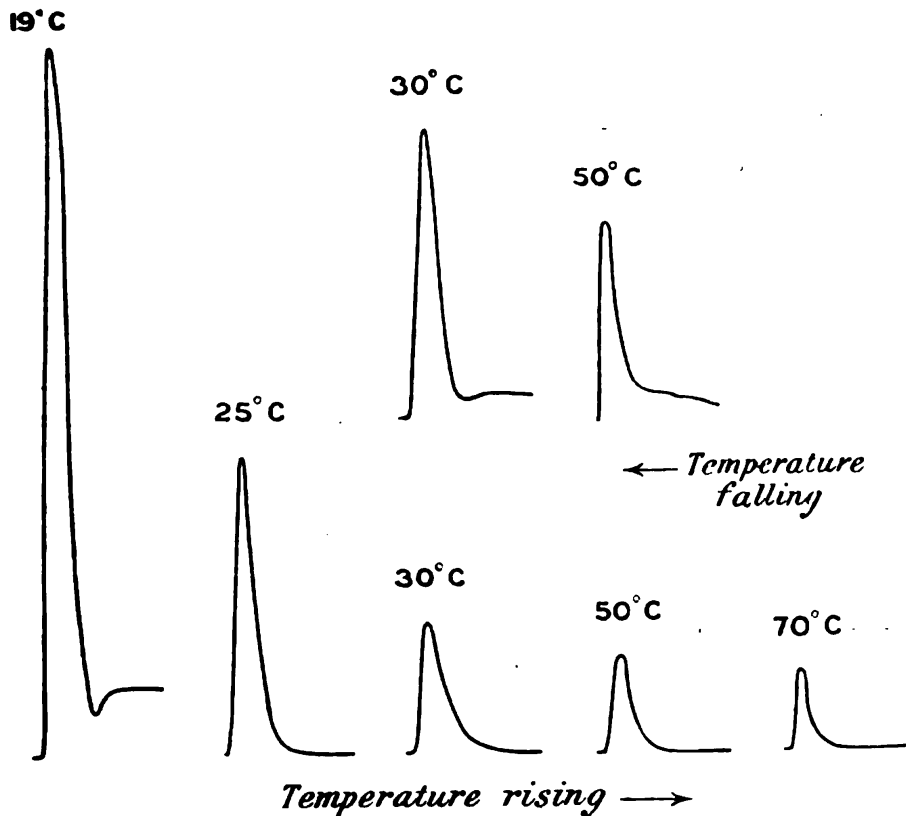

FIG. 80. Effect of Rising and Falling Temperature on the Electrical Response of Scotch Kale (stimulus constant)

in the course of my investigations on the effect of temperature by means of electrical response. This was, a marked increase

L

of sensitiveness, which often appears as the after-effect of a preceding cyclic variation of temperature. That is to say, if we take a series of responses while the temperature is rising, and afterwards a similar series while the temperature is falling, it is found that during the process of cooling, the responses are markedly enhanced in amplitude, as compared with those given at the corresponding temperatures during heating. This is seen in a very clear manner in fig. 80.

(b) *On longitudinal mechanical response.*—I have observed a very similar phenomenon in the longitudinal mechanical response of, for example, the coronal filaments of *Passiflora*. An ascending series of responses was taken at

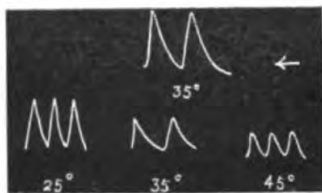

FIG. 81. Effect of Cyclic Rise and Fall of Temperature on Longitudinal Mechanical Response in Plant

temperatures of 25°, 35°, and 45° C. They exhibited a regular decrease, as has already been explained. On now, however, taking records of responses during cooling, it was found that the response at 35° C. was 50 per cent. greater than it had been when the temperature was ascending (fig. 81).

I have already explained that response is found to be abolished when the plant is killed, by raising the temperature above a certain maximum point. The exact determination of this point has hitherto been a matter of great uncertainty. I shall in the next two chapters, however, explain several methods by which this investigation may be carried out with great precision.

SUMMARY

The electrical and mechanical responses of plants undergo diminution under the influence of cold.

The latent period of response is prolonged by lowering of temperature.

When the temperature is raised above an optimum, the

responses, both electrical and mechanical, undergo a diminution.

Prolonged exposure to excessive cold or heat brings on abolition of response. Owing to cold or heat-rigor this abolition may become permanent, indicating the death of the plant.

CHAPTER XIII

ON THE DEATH-SPASM IN PLANTS

Difficulty of determining exact moment of death—Various *post-mortem* symptoms afford no immediate indication—Ideal methods for determination of death-point—Realised in four different ways: (a) Determination by electrical method—(b) Determination by spasmodic lateral movement at moment of death—Experiments with *Mimosa*—Death-contraction a true physiological response—Continuity of fatigue and death—Death-point earlier in young tissues—Composite spasmodic movement—(b') Determination of death-point in tendril of *Passiflora*, by sudden movement of uncurling—(c) Determination of death-point by method of volumetric contraction of hollow organ, causing expulsion of contained water.

IT is known that when the temperature to which it is subjected is raised above a certain maximum, a plant is killed. But it is very difficult to determine at what exact temperature this takes place. One reason of the difficulty lies in the fact that hitherto a sure criterion of death, which would give an *immediate* and reliable indication of its occurrence, has not been generally available. Its various symptoms, such as drooping, withering, discoloration, and the escape of coloured cell-sap, do not manifest themselves at the moment of death, but at some time indeterminately later. Even when a plant has been subjected to a temperature in excess of the fatal degree, it continues to appear fresh and living, and it is not till after some greater or less interval that the death-symptoms are seen. Various investigators have taken up different indications as the criteria of death, and this fact accounts for discordance in the results, which would already have been sufficiently uncertain even had a common standard been decided upon.

Exact methods of determination of death-point.—A good method for the determination of the death-point would

consist in watching the waning of a given effect, characteristic of the living condition. Still better would be the discovery of some effect suddenly and strikingly manifested at death. But the ideal method would be found, if some effect could be detected which at the moment of death would undergo sudden reversal to its opposite. In this last case, there would not be even that minor degree of uncertainty which is incidental to the determination of the exact vanishing-point of a waning effect. I have been successful in devising four distinct means, by which the death-point might be detected with precision, and it will be shown that all these different modes of investigation enable results to be obtained which corroborate each other in a remarkable manner. The four means are: (*a*) the method of electrical response; (*b*) that method by which the point of death is determined from the occurrence of a spasmodic movement, in a dorsi-ventral or anisotropic organ; (*c*) that method which depends on the sudden expulsion of water at the moment of death from a hollow organ, previously filled with liquid; and (*d*) the method in which the death-point is determined from the sudden reversal of a thermo-mechanical response-curve. I shall, in the course of the present chapter, describe the first three of these, leaving the fourth method to be treated in the next chapter.

(*a*) *Determination of the death-point by electrical response.*—As regards the electrical method, I have shown elsewhere¹ that the response of normal galvanometric negativity is characteristic of the living condition of a plant-tissue. When the plant is killed, by any means whatsoever, this normal response disappears. At the moment of death from rise of temperature, therefore, we shall have the abolition of the normal negative excitatory response. But at or beyond this point, on the other hand, we may have the positive response of hydrostatic disturbance replacing the true excitatory effect. By this electrical mode of investigation, I have been able to determine the death-points of different plants. In the following table, for

¹ Bose, *Response in the Living and Non-Living*, p. 62.

example, the specimens tested were radishes, and the experiment was conducted during the winter season in England. It would appear from the results given, that in these six cases response begins to be abolished at temperatures varying from 35° to 55° C. It will be shown later that the death-point depends on the season, being a few degrees lower in winter than in summer.

TABLE SHOWING EFFECT OF HIGH TEMPERATURE IN ABOLITION OF RESPONSE AND DEATH OF PLANT

Temperature	Galvanometric response of specimen at given temp.	Temperature	Galvanometric response of specimen at given temp.
(1) { 17° C.	70 dns.	(4) { 17° C.	80 dns.
53° C.	4 ,,	55° C.	0 ,,
(2) { 17° C. ..	160 ,,	(5) { 17° C.	40 ,,
53° C.	1 ,,	60° C.	0 ,,
(3) { 17° C.	100 ,,	(6) { 17° C.	60 ,,
50° C.	2 ,,	55° C.	0 ,,

(b) *By observation of the spasmodic movement of lateral response.*—I now turn to the second of the four methods which I have named, that in which a spasmodic lateral movement is looked for, in a dorsi-ventral or anisotropic organ, at the moment of death. It has been shown that when an electric shock of moderate intensity is applied to an anisotropic organ, say the leaf of *Mimosa*, response occurs, in consequence of molecular derangement, and recovery takes place on restoration of molecular equilibrium. If the shock, however, be excessive, response occurs, it is true, but there is no subsequent recovery, owing to the fact that the molecular derangement has passed beyond the point where restoration was possible. There is thus a permanent, irreversible 'set,' and the organ is now said to be killed.

At death, then, a sudden irreversible molecular derange-

ment is produced. It follows that if we could bring on very gradually those conditions which cause death, then, on arrival at the critical point, we might expect the irreversible molecular derangement to occur abruptly. If, further, throughout this process, the organ could be protected from stimulation, we might expect that this sudden molecular derangement would also be attended by a correspondingly sudden evidence of excitation, which would in this case, however, be at once the first indication of excitation and the last sign of life. This spasmodic movement we shall designate as the death-response.

As regards the protection of the experimental organ from accidental stimulation, it is to be remembered that excitation under ordinary circumstances depends upon some sudden variation of environmental conditions. A sudden change of temperature may thus act as a stimulating agent and produce depression of the leaf. But a gradual change will not act as a stimulus. The effect of such a gradual variation, on the contrary, as will be shown presently, is to produce no excitatory contraction whatsoever.

If now we take a specimen of *Mimosa* and place it suddenly in warm water, say at 35° C., a responsive collapse of the leaves will at once occur. But if the plant be placed in water at the ordinary temperature of the room, and the temperature gradually raised—say at a rate of 1° per one minute and a half, or thereabouts—there will be no responsive downward movement whatsoever. On the contrary, owing to absorption of water by the organ, and also to the relaxing physiological action of heat, a delicate method of record will show a slight and continuous movement upwards. This proceeds till we reach a degree of temperature which proves to be the death-point. For example, in the case of a particular experiment in summer, with a young leaf of *Mimosa*, when the temperature of 59° C. was reached, there was a sudden spasmodic movement of the leaf downwards. This was, in fact, the death-throe of the plant. In winter, after a spell of cold weather, when the physiological condition

of the tissue was somewhat depressed, this spasmodic movement was found to take place at 53° C., which exactly agrees with that of radish, under similar conditions. That this was the true death-point of the *Mimosa* specimen was proved when, on trying the electrical test, it was found that the normal electrical response had disappeared. If, again, one branch of *Mimosa* on the intact plant be bent over, and subjected in the manner described to the death-temperature, we find, on examination after a considerable lapse of time, that whereas the leaves of the rest of the plant are still fresh and healthy, reacting to stimulus, those of this branch may be seen, from their dried and shrivelled condition, to be quite dead.

Death-response a true physiological response.—It will be shown that this death-response is a true physiological response. Under normal conditions, it will be found to be extremely definite, even in different plants. But, under physiological modification, it varies appropriately with the season, age, condition of freshness or fatigue, and the action of chemical reagents. I shall first, then, demonstrate the effect of age on the death-point. Thus, on immersing a branch of *Mimosa* in water whose temperature is raised continuously, we find that the spasmodic movement of death occurs earlier in the young leaves than in the old. Young seedlings, again, have a lower death-point than mature plants. The following table gives results bearing on this fact. The death-points of different plants in the same season and of the same age are, however, so definite as to be almost like a physical constant. This will appear from the following tabular results, and also from results given in the next chapter. A fact which will be explained later must be stated here. In these experiments with continuously rising temperature, it is found that the first spasmodic movement downwards is succeeded by a later, upwards, by which time the temperature has risen a few degrees. The temperatures of both movements are given in the accompanying table, corresponding to their occurrence in two leaves, one old and

one young, of each plant tested. These experiments were carried out at the beginning of spring.

TABLE SHOWING DEATH-POINTS IN OLD AND YOUNG LEAVES OF DIFFERENT SPECIMENS OF MIMOSA

Specimen	Young Leaf-organ		Old Leaf-organ	
	Temperature corresponding to fall	Temperature corresponding to later erection	Temperature corresponding to fall	Temperature corresponding to later erection
I.	C. 59.5°	C. 61.5°	C. 60.8°	C. 62°
II.	59°	61.5°	61°	63°
III.	60°	62	61.2°	63.6°
Mean .	59.5°	61.7°	61°	62.9°

From these results it will be seen that there is a mean difference of 1.5° C. between the death-responses of old and young leaves. It would thus appear that the age of a cell must be the occasion of a certain amount of protoplasmic change, as manifested in the retardation of death-response. We may also infer that sudden change to unfavourable physiological circumstances—before the plant has accommodated itself to the changed condition—will tend to lower the death-point. This fact I found illustrated during the prevalence of an extraordinary wave of cold, which supervened recently, during the progress of these experiments. I then found that the mean death-point, in the case of various plants, was reduced by several degrees. In *Mimosa* it fell from the average of 59° C. to 55° C., *i.e.* as much as 4° C. We have thus seen that the physiological differentiation concomitant on protoplasmic change is attended by variation of death-point.

Explanation of the subsequent erection.—In animal tissues, the contraction produced by *rigor mortis* is succeeded by a relaxation. The contractile death-spasm in a plant is, similarly, followed by the relaxation seen in the subsequent

erection of the leaf. There is another and very interesting point of view, from which we may see in this phenomenon the continuity of fatigue with death. In the curve of reversal, due to fatigue, in *Mimosa*, we saw that the first contraction, induced by strong and long-continued stimulation, passed into subsequent relaxation. In this latter state, the molecular condition was such that responsiveness was abolished. It was as if, in other words, the tissue had passed into a temporary state of death. It is true that, if the stimulation had not been excessive, the organ would recover its sensitiveness, after a period of rest. But this transient would pass imperceptibly into the permanent condition of death if, on the other hand, stimulation had been excessive. In that case, after the fatigue-reversal, the tissue would remain permanently irresponsive.

I have already said that the death-spasm is an instance of excitatory response to intense stimulation, and we should therefore expect the same kind of effect to be produced as is caused by excessive stimulation, that is to say, a preliminary contraction, followed by relaxation, after which there is no recovery. Again, we saw that in the fatigue-reversal of *Mimosa*, the subsequent erection of the leaf, mainly due as it was to relaxation, was possibly also aided by the later contraction of the less excitable upper half of the pulvinus. Similarly, it might be expected that the death-contraction of the less excitable upper, would take place slightly later than that of the lower, half of the pulvinus. We have also seen that the excitability of a tissue declines with age, and this decline would naturally be greater in the more excitable half. Thus the difference of excitability as between the two halves would at the same time tend to disappear. As, then, this spasmodic movement in dorsi-ventral organs is a true instance of differential excitatory response, it would appear that the younger the organ, the greater is the excitatory spasm caused by death, and in experimenting with *Mimosa* I have found that at the death-point hardly any spasmodic movement is shown by old leaves. These considerations will also explain

why older leaves give less motile indication than the young, in response to stimulus in general.

(b') *By observation of spasmodic movement of uncurling.*— I shall now proceed to demonstrate that the death-movement which we have seen in *Mimosa* is in its essentials characteristic of anisotropic response in general; and this may be shown by taking a spiral tendril of *Passiflora* which has become anisotropic by curling. In order to detect and measure with ease the responsive movements of uncurling and curling the experiment is arranged as follows: a light index is attached to the tip of the spiral, and the whole is immersed co-axially in a glass cylinder filled with water. A strip of paper, marked with degrees, is wrapped round the outside of the cylinder on the plane of the index. The temperature of the water is now raised very gradually, and the responsive excursion of the index is read on the graduated circle formed by the paper.

It is to be borne in mind that the true excitatory response of the tendril is given by uncurling, which here corresponds to the fall of the leaf of *Mimosa*; thus the movement of erection would be represented by that of curling. In the case of *Mimosa* we saw that the first effect during rise of temperature (due to absorption of water and relaxation) was slow and gradual erection. On the arrival of the death-point of the organ, however, this preliminary rise was succeeded by a sudden responsive fall. The subsequent relaxation of death then produced an opposite movement, of erection. Similarly, in the death-response of the spiral tendril of *Passiflora*, we observe parallel phases. There was first a slow and continuous movement of curling, during the preliminary stages of warming. But this movement ceased when a temperature of 57° C. was reached, and the tendril remained stationary for a time. At 59° C., however, there was produced a sudden excitatory response of death by an uncurling, executed with great rapidity, an angular movement of 360 degrees being described by the index during the course of the next few degrees of rise in temperature. With regard

to the short stationary period, it is to be borne in mind that the death-point depends on the age of the tissue, and in the tendril we have different parts in different stages of growth. Hence while the uncurling movement of death was being initiated in younger portions, older parts of the tendril were still moving in an opposite direction. The outcome of these antagonistic movements was a resultant pause, which only lasted for a little while, and was followed by the vigorous movement of uncurling, caused by the death-contraction of the whole tissue. After the completion of the uncurling movement, there followed the opposite, namely, the movement of *post mortem* relaxation. In a second experiment with a younger specimen of tendril, I obtained results almost identical. Here the uncurling response of death began at one degree of temperature earlier, namely at 58° C., and the index moved through 150 degrees of the circular scale.

On the subject of the death-contraction of the radial organs of ordinary plants, I shall speak in some detail in the next chapter, and shall there describe the perfected apparatus by which the thermo-mechanical response can be continuously recorded, the curve exhibiting the death-point with great precision.

(c) *By observation of volumetric contraction, causing sudden expulsion of water.*—For the present I shall describe only the third of those methods which I have enumerated for the determination of the death-point, that namely which depends on the sudden expulsion of water, at the moment of death, from the hollow organ of an ordinary plant, previously filled with liquid. The specimen used for the present demonstration will be the peduncle of *Allium*, although there are many tubular organs of various species of plants which are more or less suitable for these experiments.

We cut a length of about 10 cm. from the middle of a peduncle of *Allium*, rejecting the too young and too old portions at top and bottom. As the presence of air-bubbles is likely to be disturbing to the experiment, the water used must have been previously boiled. The specimen is placed in

a vessel of this water, and as a further precaution against air-bubbles clinging to the interior of the tube, the whole may be put inside the receiver of an air-pump and subjected to a repeated partial vacuum. The removal of air-bubbles may also be effected by rinsing the tube of *Allium* in water containing a small quantity of ether, and immediately afterwards washing with ordinary water. This must be done, however, with caution, as the presence of an appreciable quantity of ether would be likely to affect the excitability of the tissue. Before commencing the experiment, it is advisable to allow the specimen to remain immersed in water for about half an hour, by which time it becomes fully turgid.

The lower end of the *Allium* tube filled with water is closed by a piece of solid glass rod, and the upper end is also closed with a piece of glass tube, having a capillary bore. A graduated scale is placed behind this latter, so as to measure the movement of the water-index, or this movement may be continuously recorded on a revolving drum (fig. 156). The *Allium* preparation is now placed in a vessel of water, and subjected to a gradual rise of temperature in the manner already described.

If, at the temperature corresponding to death, there should now be a sudden excitatory contraction of the *Allium* tissue, the volumetric change thus produced will force out the contained water, and we shall observe a relatively rapid expulsive movement of the water-index. From the curves given above in fig. 82, it will be seen that this occurs at a temperature of 59° C. in a younger, and at 63° C. in an older specimen. Previous to this, there was an inward movement of the water-column corresponding to the gradual

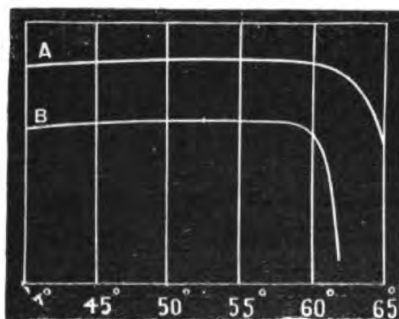

FIG. 82. Determination of Death-point in *Allium* Tube by Observation of Volumetric Contraction, causing sudden Expulsion of Water

A, record given by older specimen ; death-point 63° C. B, record of younger specimen ; death-point 59° C.

preliminary rise of the *Mimosa* leaf or curling of the *Passiflora* tendril. But at the death-point this movement was at first arrested, and then reversed with accelerated speed. The condition of this particular specimen was afterwards tested by the electrical method, when it was found that, while a portion of the peduncle previously cut off gave the normal response of living tissue, the specimen which had been subjected to the death-temperature gave no response.

SUMMARY

The death-point of a plant, under heat-rigor, is concomitant to the disappearance of the true excitatory response of galvanometric negativity. After this point is passed, hydrostatic disturbance generally gives rise to the reverse positive response.

When an anisotropic organ like the pulvinus of *Mimosa* is gradually raised in temperature, then, at a certain critical temperature, a spasmodic movement is produced which proves to be the death-response of the organ. This is a true excitatory response. The critical death-points of similar specimens are very definite and practically identical.

The death-point is modified by the physiological condition of the tissue. Other things being equal, death occurs earlier with a young than with a mature tissue.

The death-response of an anisotropic organ is composite. In *Mimosa* it consists of a down, followed by an up, movement. This is due to the death-contraction being followed later by the *post-mortem* relaxation of the organ.

In the spiral tendril of *Passiflora*, the death-response is given at the critical point by a sudden uncurling.

In the case of the hollow peduncle of *Allium*, the death-response is exhibited by volumetric contraction, producing sudden expulsion of contained water.

CHAPTER XIV

THE DETERMINATION OF THE CRITICAL POINT OF DEATH BY INVERSION OF THE THERMO-MECHANICAL CURVE

Death-spasm in anisotropic organ due to differential longitudinal contraction—In radial organ the death-contraction is purely longitudinal—Death-point determined from point of inversion of a thermo-mechanical curve—The complete record thus constitutes a curve of life-and-death, the two being separated by the death-point—Characteristic thermo-mechanical curve as resultant of variation of temperature and variation of length—The necessity of specifying the rate of rise of temperature—The thermo-mechanical curve characterised by sharp and definite inversion at point of death—No inversion of thermo-mechanical curve after death of plant—Death-contraction under heat-rigor in plant analogous to similar phenomenon in animal—The *Morograph*, a perfected form of apparatus for determining critical point of death—Remarkable identity of thermo-mechanical curves obtained with two similar specimens—Death-point almost as definite as a physical constant—Vanishing of point of inversion with age—Determination of death-point under cold-rigor—Constancy of death-point.

WE have seen how the death-point can be determined in anisotropic organs, by the occurrence of a spasmodic lateral movement. We have also seen that this death-movement is an excitatory response, at once initiated and terminated at the point of death. It has been shown further that the anisotropic is simply an instance of differential longitudinal response. It follows that if the death-spasm in the anisotropic organ be indeed caused by true excitation, then from a radial organ, at the moment of death, we should obtain a purely longitudinal contraction. We may look upon this phenomenon, again, from a purely molecular standpoint. We can then see that if death be brought about by a sudden molecular change, such an event might be expected to exhibit itself in a correspondingly sudden change of form. Let us

then take a radial tissue, and subject it to a gradual rise of temperature, taking a continuous record of its variation in length. From what has already been said it will be understood that, the variation being gradual, no responsive contractile effect will be induced during the process, but, on the contrary, some relaxation. At the death-point, however, a sudden inversion of the curve, due to death-contraction, may be expected to appear, and thus the whole record will constitute a curve of life-and-death, this point of inversion separating the two. Should the inversion prove to be very abrupt, the turning-point will afford us a means of determining the temperature at which death occurs, with very great accuracy.

In order to prove, further, that this specific response is definitive, we may, after passing the death-point, bring the tissue back to its original temperature once more, and repeat the process. The record ought now to show no inversion characteristic of a transition from life to death.

Means of obtaining thermo-mechanical record.—I shall now proceed to describe the manner in which I have obtained this thermo-mechanical record. I took a specimen of a radial organ, in this case the long style of *Datura*, and fixed it to a small glass rod which in its turn was fastened to a weight, the whole being placed in a vessel of water. The free end of the style was attached to one arm of the Optic Lever. The bath was now warmed gradually, a thermometer indicating the rise of temperature. Variations of length corresponding to the rise of temperature were progressively recorded, from the movement of the spot of light. For this purpose the mode of procedure was as follows: The vertical movement of the spot of light—occasioned by the variation of length of the specimen—was converted into lateral, by reflection from a second mirror. The paper wrapped about the recording drum was divided into millimetres. It was required that the abscissa of the thermo-mechanical curve should represent temperature, and the ordinate the corresponding length. The position of the spot of light, at any given temperature, was marked on the drum. At each rise of temperature of

1° C. the drum was rotated, say, through a distance of 2 mm., and the position of the spot recorded. In this way, by connecting the recorded points, a curve was obtained, in which the length corresponding to each temperature was known. In this curve an abrupt inversion, due to sudden death-contraction, was found to occur at about 59° C. The curve thus obtained, however, though the successive points recorded were very near each other, is the result of intermittent observations. Again, two observers were required, one to read the temperature, and the other to take the record. It was therefore subject to error of thermometric reading.

Means of obtaining automatic record.—For this reason I was desirous of obtaining a curve which should be continuous and practically automatic, the plant itself being made to record its own variations of length, and its own death-point. The problem resolves itself into that of making the reflected spot of light partake of two motions simultaneously, namely, a horizontal movement proportional to the change of temperature, and a vertical movement proportional to change of length. The horizontal, or thermometric, component of the movement I secured as follows: I constructed a thermo-electric element of iron and nickel, one junction of which was placed in melting ice, and the other junction in the vessel of water containing the specimen whose temperature was being subjected to change. This element was placed in circuit with a resistance box and a sensitive reflecting galvanometer. The amount of the movement of the galvanometer spot of light could now, by interposing suitable resistance, be brought to any appropriate value. In my experiments, with a particular galvanometer, the movement of this spot of light, for each degree of rise of temperature, was 2.5 mm.—*i.e.* one-tenth of an inch—when the recording surface was at a distance of 125 cm. from the galvanometer. This extent of movement was quite sufficient for the purposes of the experiment, as it enabled estimates to be made with ease, correct to one-fifth of a degree. By interposing smaller resistances, however, one-twentieth of a degree could easily be discriminated. The excursion of the spot of

M

light was now found to be strictly proportional to the rise of temperature.

In order to combine this horizontal thermometric movement with that vertical movement occasioned by the variation in length of the specimen, the vertically moving spot of light from the Optic Lever was thrown on the galvanometer-mirror. The apparatus, it should be mentioned, was so arranged that the two mirrors were as close together as possible. The spot of light now, having been reflected from two mirrors, directly described a curve in which the abscissa gave temperature-variation, and the ordinate, variation of length. When the source of light is a point, that is to say, a pinhole with electric light behind—the excursion of the reflected ray upon a photographic plate will produce an automatic record. Or the movement of the light may be followed continuously with a pen.

Conditions for securing accurate death-point.—Here I must point out certain conditions which must be kept in view if we are to obtain a very definite death-point. We know that if a plant be placed in an unfavourable environment, or in a temperature much above the optimum, for a prolonged period, death will ultimately ensue. But inasmuch as these temperatures would only cause the death of the plant by indirect and cumulative action through progressive derangement of the several functions, they cannot in themselves be said to constitute death-points. To be scientifically precise in such a determination it is necessary that we should discover a temperature which is of itself efficient to initiate sudden death. On the other hand, again, as the contraction of death is a phenomenon of response, we see that it must have a certain latent period. Some interval elapses, moreover, during which the tissue is attaining the temperature of the bath in which it is placed. Now if the rate of rise of temperature be too rapid, then, owing to the lag caused by these last two factors, by the time the death-response commences, the recorded temperature may have gone beyond the actual death-point.

We thus arrive at two conditions which must be regarded as mutually somewhat antagonistic. In the first place, in order to obtain the immediate point of death, it is essential that the plant undergo an exposure which is not too prolonged. In order, on the other hand, to make due allowance for the latent period and for attainment of the surrounding temperature, the rate of rise must be gradual and definite. In the case of tissues which are not too thick, the latter of these conditions is amply fulfilled by a rate of 1° C. per minute and a half. We see, therefore, that in precise determinations of the death-point, the rate of rise must always be specified.

With thick stems, however, owing to relative want of thermal conductivity, the attainment of surrounding temperature and occurrence of death throughout the whole of the organ is a very protracted process. The experiments which I shall describe were made with specimens which were not too thick, death at the fatal point being ensured, when the rate of rise of temperature was that prescribed, namely, 1° C. per every minute and a half.

This definite rate of rise may be secured by using an electric heating apparatus, such as is commonly employed for boiling a tea-kettle. The current from the street-mains, which is 220 volts, heats water too rapidly. But the desired rate may be obtained by interposing an electrolytic rheostat of copper sulphate, the current being brought to a suitable value, by separation of the two electrodes through which the current enters and leaves the electrolyte.

In this case, when placing the specimen in the experimental bath, it is advisable to secure it to a bent glass rod, which rests outside. For if it is placed in the metallic vessel itself, the record will be subject to a certain disturbance, owing to the expansion of the supporting metal while heating. The expansion of the glass rod is so small as to be negligible. In this way, using for experiment a filament of the corona of *Passiflora*, I obtained a record, showing a very abrupt inversion, corresponding to the death-point, which was

M 2

between 59° and 60° C. I shall presently have occasion to describe in detail the various characteristics of this curve.

Having described the apparatus with which these curves were recorded, it is necessary to point out the difficulties which were encountered in working with it. It must be remembered that the excursion of the spot of light, in this case, represented a high magnification of the actual movements involved. The spot of light, moreover, was reflected from two separate instruments, and was liable to be disturbed by the slightest jar or tremor in either of them. Though the instruments were placed on a steady stone pedestal, even this precaution could not be made wholly effective, in the heavy traffic of a town. It was only, therefore, in intervals of quiet that approximately perfect results could be obtained. This difficulty led me to the devising of a much simpler and more perfect instrument, which I shall designate as the *Morograph*.¹ This is a small and portable apparatus, self-contained, in which the necessity of a galvanometer is obviated. By its means, moreover, the record is unaffected by any earth-vibration.

The Morograph.—The thermometric record is produced by means of the curling and uncurling of a spiral compound strip, of two metals, having different coefficients of expansion. In order to give strength and steadiness, this helix, which is about 2.5 cm. in diameter, is made of somewhat thick strips of brass and tinned iron, soldered together. By increasing the number of turns in this spiral, the extent of movement per degree in the thermometric record may be increased at will. In my own *Morograph*, a helix of three circles was found to answer all requirements. The last half-circle of the lower end of the spiral is fixed to a heavy circular stand of brass, 3 cm. in diameter. The topmost half-circle, on the other hand, has had the tinned-iron strip cut off, and therefore consists of brass alone. It will thus be understood that a line drawn diametrically across this last half-circle

¹ This word is derived from the Sanskrit root *mri*, Latin *mors*, death.

would rotate round a vertical axis passing through the centre of the spiral, under the influence of the differential expansion or contraction produced in the compound strip of metal by rise or fall of the temperature. When the outside of the circumference of the spiral consists of the more expansible metal, brass, then a rise of temperature will produce the movement of curling. The difficulty in the construction of this part of the apparatus lies in securing equal angular rotation of the diameter about the axis, with every equal rise of temperature. These indications were at first extremely irregular. I was able, however, to remove all traces of irregularity by careful and repeated annealing. In any case the thermometric indications of the compound helix may be previously calibrated.

The axis of the Optic Lever—one arm of which is attached to the plant-specimen, and which is to give the record of its variation in length with rise of temperature—is now supported on the diameter of this last half-circle of the helix and is thus rotated bodily, with rise of temperature (fig. 83). And it will thus be seen that the motion of the spot of light, reflected from the single mirror of the Optic Lever, is a resultant of two movements, which take place at right angles to each other—namely, the horizontal movement, due to thermometric variation and the corresponding vertical movement, due to the changes of length of the experimental plant-tissue. Owing to the fact that the spot of light in this apparatus is reflected only once, it is extremely bright.

I shall now proceed to describe the manner in which the plant is mounted, and other accessories of the apparatus.

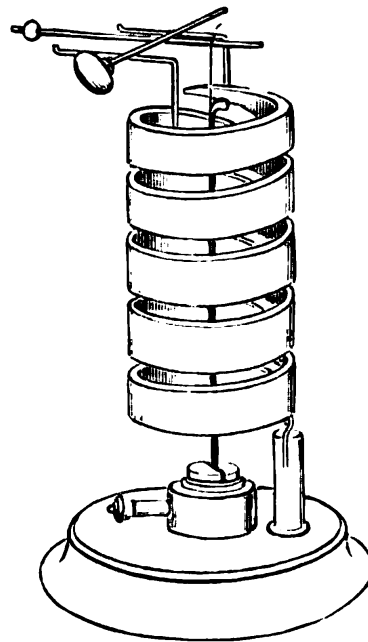

FIG. 83. The Thermometric Spiral and Optic Lever of the Morograph

The circular brass stand on which the helix is mounted has at the centre a small tube, in which the lower part of the specimen is clamped. The plant-organ thus occupies the vertical axis of the spiral, its upper end being connected by a thread with the short arm of the Optic Lever. It may be pointed out here, as is better explained in the diagram, that in order to give room to the specimen, the axis of the Lever is made to rest upon T-pieces, which are erected at the two ends of the diameter of the helix. The plant-organ being thus placed at the centre, the inclosing spiral thermometer gives an accurate indication of the temperature to which it is exposed.

The circular stand, supporting both the specimen and the recording apparatus, is placed in what I shall describe as the inner thermal cylinder, within the circumference of which the base fits exactly, while the helix is free, to the extent of 25 cm. all round. This internal cylinder is made of copper, coated with silver. It is filled with water and placed inside an outer, or heating, cylinder of brass, which is also filled with water. Heat is applied, by means of a spirit-lamp, to the bottom of the outer cylinder; thus the water in the inner vessel is subjected to equal heat, on all sides at the same time. Had the heat been applied directly to the inner cylinder, convection-currents would have caused great disturbance of the recording spot. With these precautions, however, there is no trace of such disturbance.

The whole apparatus is supported on a steady stand. Below it is the spirit-lamp, which may be raised or lowered till a distance is found which gives us the standard rate of rise of temperature, that is to say, 1° C. per minute and a half. Above the apparatus and on a sliding holder is the electric lamp, with focussing lens; the light from this falls vertically on the mirror of the Optic Lever, which is inclined at an angle of 45° to the horizon. The horizontally reflected light is then thrown on a screen, which carries either semi-transparent recording paper or a photographic plate. In the former case the observer, standing behind the screen,

- traces the movement of the spot of light with a pencil. The whole recording apparatus and the source of light being thus placed on the same stand, any ordinary disturbance will affect all equally, and cause no irregularity therefore in the movement of the recording spot (fig. 84).

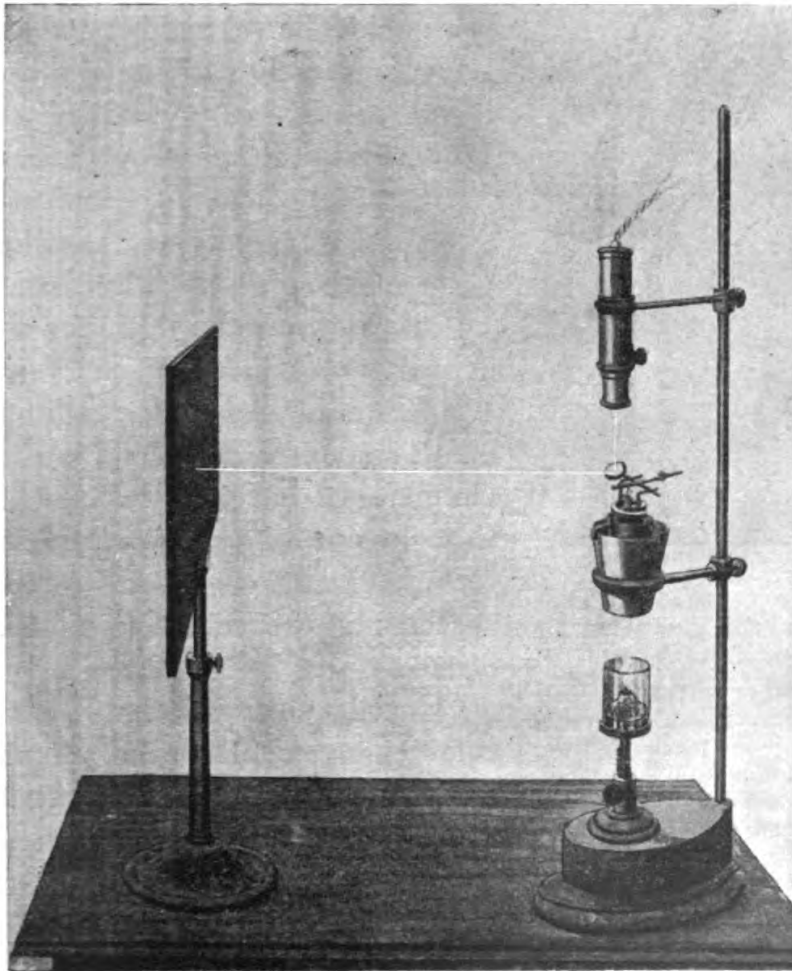

FIG. 84. The Morograph

Record may be taken by following excursion of spot of light on screen to the left.
For photographic record, plate-holder is substituted for screen.

I have given a great deal of space to the description of these details, because on them depends the accuracy and perfection of the results. The record may now be made on any scale of magnification, without misgiving. In fact

I have obtained very perfect records even when the passing traffic was at its thickest. How true this is may be seen from the photographic record of a thermo-mechanical curve, given in fig. 85.

It will be noticed from the curve that, as the temperature rose, there was a continuous preliminary elongation, which



FIG. 85. Thermo-mechanical Curve obtained Photographically (Coronal Filament of *Passiflora*)

The first or down part of the curve shows relaxation, but on reaching death-point, at 59.6° C., there is a sudden inversion of the curve, due to spasmodic death-contraction.

was suddenly reversed by the excitatory contraction at the death-point, found in this case to be 59.6° C. If desired, the photographic curve itself may be made to indicate the different temperatures at different parts of the curve. This is secured by interrupting the light for a time at, say, every half degree of rise of temperature. As in the anisotropic death-responses, described in the last chapter, we have in this case also, though not shown in the present record, the *post-mortem* relaxation succeeding the contraction of *rigor mortis*.

In order to show that the molecular change which occurred at the point of inversion was indeed the irreversible death-change, I took the curve once more, after allowing the specimen to return to its original temperature. The curve now obtained showed no reversal-point.

Remarkable agreement between thermo-mechanical curves of similar specimens.—It was pointed out in the last chapter that the death-point is almost as definite as a physical constant. And not only is this true of the death-point, which I find in different phanerogamous specimens, under normal conditions, to be almost invariably close upon 60° C., but it is also more or less true of the whole curve, those given by similar specimens being almost identical. In this way

the thermo-mechanical curve is, in a sense, characteristic of the plant in a given condition. This is well seen in the two records which I have obtained from the styles of two flowers—both on the point of opening—of a single plant of *Datura alba* (fig. 86). These two curves are so extraordinarily similar in all their parts, that I was obliged, in printing them, to raise the origin of one slightly above that of the other. If the point of origin had been allowed to remain the same in both, one would have been superposed upon the other, so as to prove almost indistinguishable. On minute examination, however, I find that the death-point of one differs from that of the other by about $\frac{1}{10}$ of a degree.

The possibility of securing such uniformity of results, enables us to attempt an investigation on the influence of various agencies. For any deviation from the standard characteristic curve will then form an indication of the action of such agents.

Standardisation of curves.—Different plants, again, will exhibit differences in their characteristic curves, and in order to render these strictly comparable with one another, we must know the absolute value of relaxation or contraction in each part of the curve. By absolute value, is here meant the amount of relaxation or contraction per unit-length of the specimen. This is rendered simpler if we adopt a uniform standard for all specimens; that is to say, the horizontal distances representing temperature may in the standard curves be $\cdot 1$ inch (2.5 mm.) per degree. Vertical distances, again, of $\cdot 1$ inch may be made to represent a relaxation or contraction of one part in a thousand. The standardisation is carried out in the following way: first, the recording surface is moved,

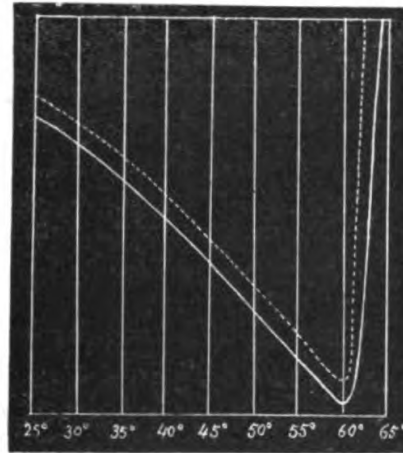

FIG. 86. Thermo-mechanical Curve of Two Different Specimens of Style of *Datura alba*, obtained from Flowers of the same Plant

till one degree of rise of temperature produces a horizontal movement equal to .1 inch. After this, keeping the distance of the recording surface constant, the length of the short arm of the Lever, to which the plant is attached, is so adjusted that the vertical magnification is two hundred times. The length of specimen used, unless the contrary is stated, is

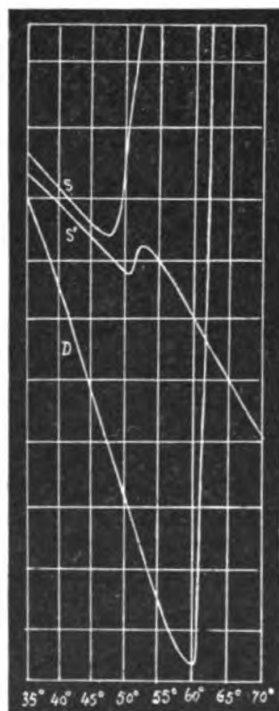

FIG. 87. Thermo-mechanical Records of *s*, Young Specimen of *Spirogyra*; *s'* Older Specimen of same; and *D*, Style of *Datura alba*

The distance between two horizontal lines represents a contraction or relaxation of 1 per cent.

always 5 cm. A movement of the light-spot through a vertical distance of one division (.1 inch) will then represent an expansion or contraction of one part in two hundred of a specimen whose length is 5 cm., that is to say, one part in a thousand of a specimen whose length is one centimetre. In fig. 86, the original record has been reduced to one-fourth. The distance between two horizontal lines represents a contraction or relaxation of 1 per cent.

In order to exhibit the differences in the characteristic curves of different specimens, or of the same specimen at different ages, I append three records taken under the same standard conditions: (*D*) that of the style of *Datura alba*; (*s*) of a young specimen of *Spirogyra*; and (*s'*) of an older specimen of the same (fig. 87). In these three experiments, the rate of rise of temperature and other circumstances having been the same, it is

instructive to compare the different parts of the different curves.

Taking first the curve of *Datura*, we find its death-point to occur at 60° C. The relaxation undergone by the specimen during the rise of temperature from 35° C. to the death-point, was at the mean rate of 2.1 parts per thousand per degree for the

unit-length. This, for convenience, we shall call the coefficient of relaxation. But after the death-point, the sign of response undergoes an abrupt change to the negative, that is, contraction, the coefficient of contraction being fifty per thousand, or nearly twenty-four times the coefficient of relaxation.

The next specimen whose curve (s) is given was young *Spirogyra* of light-greenish colour. From the slight differentiation of these simple algal forms, and from their lack at this young stage of any efficient protecting envelope, we should expect them to offer but feeble resistance to the effect of heat, and we find the death-point lowered to 47° , that is to say, 13° below that of the phanerogam *Datura*. Along with this, we find also a difference in the coefficients of relaxation and contraction. The mean coefficient of relaxation was in this case '001, and that of contraction '007.

Vanishing of point of inversion with age.—The older specimen of *Spirogyra* (s'), taken from the same place, had its point of inversion raised by 4° , the death-point being therefore at 51° C. There is a further and interesting difference as between curves for young and old specimens. In the younger specimen there was produced a very considerable contraction due to rigor, and this was followed after a time by the usual *post-mortem* relaxation. But in the older specimen the rigor was relatively slight and the subsequent relaxation took place much earlier. We thus see that there is a great loss of contractile power in old tissues. In still older specimens the contraction tends to vanish altogether, and we have no line of demarcation to mark the moment of transition from life into death. In connection with this, it is interesting to note that, whereas the death-spasm in young leaves of *Mimosa* is very vigorous, old leaves exhibit little or no spasmodic lateral movement at death.

Cold-rigor.—Turning from the effect caused by continuous rise of temperature, I shall now proceed to the consideration of the effect produced by the reverse process of continuous fall to the minimum temperature. Here also, as in the case of the curve for rising temperature, there is a

Sudden inversion at a definite minimum point of temperature. That is to say, just as we observe a sudden contraction when the point of heat-rigor is reached, so also we obtain a similar sudden contraction at a point corresponding to the cold-rigor. For example, with the style of *Eucharis* Lily, which is very susceptible of depression by cold, I found the death-point to be at about 1° C. The experimental difficulties for the determination of cold-rigor are, however, very great, owing to the fact that facilities do not exist for continuous lowering of temperature to zero or below.

Thermo-mechanical record of Mimosa.—At the beginning of this chapter it was stated that the death-spasm in an

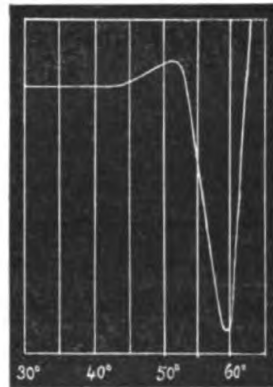

FIG. 88. Thermo-mechanical Record of Leaf of *Mimosa*

The spasmodic contraction shown here as downward movement took place at 54° C., the normal death-point being lowered by 5° owing to prevailing cold. Subsequent erectile movement took place at 60° C.

anisotropic organ, such as that of the pulvinus of *Mimosa*, was an instance of differential longitudinal excitatory contraction. The accompanying curve (fig. 88) was obtained by means of the *Morograph*. We must remember that in this case we are dealing with a differential action. In the first part of the curve, therefore, we do not obtain such marked relaxation as in radial organs, where we obtain non antagonised and direct change of form. But when we reach a temperature which corresponds to the death-point, that is to say, 54° C., there is a sudden downward movement. It must be remembered that this particular experiment was carried

out just after the spell of cold weather, when the death-points of plant-organs were found to be lowered by several degrees. After the downward movement, which commences at 54° C., we see that there is an equally abrupt upward movement, beginning at 59° C., due to *post-mortem* relaxation aided by the later contraction of the upper half of the leaf.

A few words may be said here with regard to these successive movements. As in animals the *rigor mortis* is succeeded by relaxation, so also in radial organs, as has been said, we see relaxation succeeding the death-contraction. It may then be asked whether the second half of the present curve, in fig. 87, giving the rise of the leaf, does not simply represent a similar relaxation, in the case of the pulvinus of *Mimosa*. But we have to notice that, in taking records with the Lever, the weight of the Lever ensures the indication of any passive relaxation of the specimen. If we inspect a *Mimosa* leaf, however, during the death-spasm, the leaf being free, *i.e.* unconnected with the Lever, we find that it, after its first fall, becomes again almost vertically erected, evidently in consequence, at least to some extent, of some process of active contraction, which must be that of the upper half of the organ. Had there merely been a general relaxation of the whole pulvinus, caused by death, then the weight of the leaf might have caused it to fall.

The slope of the curve of relaxation, again, is, generally speaking, relatively gentle. Its comparative steepness, in the case of *Mimosa*, after the passing of the death-point, seems to indicate that the movement of relaxation was partially aided by later contraction of the upper half of the pulvinus.

Constancy of death-point.—Before concluding the present chapter, I must refer to the remarkable fixity of the death-point in all the phanerogamous plants which have come under my observation in normal conditions. Thus, on repeating my experiments at the end of spring, by the perfected method of a morographic record, I invariably found that the point of inversion was at, or within $\frac{1}{10}$ of a degree of, 60° C. Other and less perfect modes of investigation, such as the spasmodic lateral movement of a dorsi-ventral organ, the movement of uncurling, the sudden expulsion of water, and those opening and closing movements of flowers which are to be described in the next chapter, enabled us to obtain death-points which were not very different from this. I give below

a tabular statement which makes it possible to see at a glance how concordant these results are.

TABLE SHOWING DEATH-POINTS OBTAINED BY DIFFERENT METHODS

Specimens	Method	Death-point
1-6 { Coronal filament of <i>Passiflora</i> . [Six specimens used. Each gave]	Morograph.	C. 60°
7-10 { Style of <i>Hibiscus</i> [Four specimens. Each gave]	"	60°
11-14 { Style of <i>Datura</i> [Four specimens. Each gave]	"	60°
15. Pulvinus of <i>Mimosa</i> . Young .	Spasmodic lateral movement.	59°-60°
16. Spiral tendril of <i>Passiflora</i> .	Movement of uncurling.	59°
17. Peduncle of <i>Allium</i> . Young .	Expulsion of contained water.	59°
18. Flower of French Marigold .	Opening or closing of flower.	59°
19. Flower of <i>Ipomœa</i>	" " "	62°

It will thus be seen that, using very diverse methods and specimens, we nevertheless always obtain a death-point which is very near 60° C.

SUMMARY

In radial organs, the death-contraction due to heat-rigor is abrupt, and takes place at a definite temperature, which is to be regarded as the death-point.

In the thermo-mechanical curve given by the Morograph, the point of inversion is the death-point.

When death has taken place, a repetition of the experiment shows no inversion.

The death-point, due to heat-rigor, in phanerogamous plants, under normal conditions, is found, though obtained by various methods, to be very close on 60° C.

Under the action of continuous lowering of temperature there is produced, at a definite minimum degree, a spasmodic contraction, due to cold-rigor.

The death-contraction in plants is in every respect similar to the same phenomenon in the animal, and is an instance of true excitatory effect. As in the animal, so also

in the plant, this rigor of death is succeeded, after a time, by passive relaxation of the tissue.

The thermo-mechanical curves of two similar specimens—that is to say, two specimens of the same plant, having the same previous history—are found to be practically identical.

Different plants have different characteristic curves. The curve of the same plant also exhibits a variation of its characteristics under changed conditions of age, experiment, and previous history.

CHAPTER XV

EFFECT OF VARIOUS AGENCIES ON DEATH-RESPONSE : THERMOGRAPHS OF REGIONAL DEATH

Lowering of death-point by fatigue—Modification of characteristic thermo-mechanical curve by the action of chemical agents—*Comparison-Morograph*—Duplication of rigor-point—Death-response a physiological response and not due to coagulation—Death-movement of flowers—Approximate constancy of death-point of florets in a capitulum—Definite interval between death-point and discoloration-point—Translocation of discoloration-point by various agencies—Thermographs of regional death—Thermograph of local fatigue—Thermographic investigation of electrotonic excitation.

I HAVE shown that the death-contraction is a phenomenon of excitatory response. We might expect from this that various conditions which affect the excitability of a plant would also have a modifying influence upon the characteristic thermo-mechanical curve of death-response. One such modification would lie in the translocation of the point of inversion, or, in other words, in the displacement of the death-point. In order to test this inference we might subject the plant to the influence of various agents which modify the physiological condition, and observe the consequent modification of the death-response. We have already seen how the physiological modification induced by age causes displacement of the death-point. We have seen, further, how unfavourable seasonal conditions, such as sudden prevalence of cold, will lower the death-point by several degrees. We shall now study the effect of other agencies, such as fatigue, and the action of chemical reagents, in producing displacement of the death-point.

Effect of fatigue.—In the course of these experiments, fatigue was produced by means of tetanising electric shocks,

care being taken that these should not be strong enough to kill the plant. I have carried out experiments on this subject with two different classes of specimens: first, with anisotropic pulvinated organs, like that of *Mimosa*, where the death-spasm is shown by lateral movement; and secondly, with radial organs, like the style of *Datura*, where the death-point is determined by thermo-mechanical inversion. In experimenting on *Mimosa*, I took a batch of young leaves of the same age, whose death-point was found to be at, or close upon, 59° C. After fatigue caused by moderate stimulation, however, the death-point was found to be at 56° C., that is to say, it had been lowered by 3° .

Working with *Datura* pistil, the death-point of which was never normally lower than 60° C., it was found when fatigued to be at 41° C. The lowering in this case was therefore about 19° . It will thus be seen that fatigue does lower the death-point of a plant, the degree to which it does so depending on the extent of the fatigue. In the course of the present chapter, I shall be able to demonstrate once more the lowering of the death-point through fatigue, by means of an altogether different mode of investigation.

Effect of chemical reagents.—Similarly I find that death-response is modified by the action of various chemical reagents. We have seen how characteristic is the thermo-mechanical curve of each plant, under definite conditions. We found, for example, that two styles of two different flowers on the same plant, having had the same previous history, gave curves which were practically identical. Specimens thus resembling each other are not difficult to obtain in spring, when there is no sudden variation of weather conditions, or from plants grown under glass, in an unchanging environment. The characteristics of the thermo-mechanical curve being so constant, the effect of a given agent will then be indicated by certain variations from the normal. Thus, on taking a thermo-mechanical curve—the specimen used being the style of *Datura*, subjected to the action of a 2.5 solution of copper sulphate—I found that the form of the curve was much

N

modified in contrast with the normal curve. The most striking difference lay in the lowering of the death point by 3° C.

Comparison-Morograph.—In order to facilitate the investigation into the modification of the curve, by various agents, I have devised a *Comparison-Morograph*, by means of which the thermo-mechanical curves of two similar specimens, one under normal and the other under modified conditions, can be taken simultaneously. We use here two recording Optic Levers, supported on a single thermometric helix. The normal specimen is placed in the internal cylinder in the ordinary way and attached to one of the Optic Levers. The second specimen, contained in a small cylindrical tube, filled with the given chemical reagent, is also placed inside the helix and the plant is attached to the second Lever. The spots of light are so adjusted that one lies immediately above the other. The two specimens are thus subjected to the same temperature-variations, and the variation of the second curve from the standard exhibits the effect of the reagent.

I can here barely indicate the very extended line of inquiry thus opened out. With regard to the general effect of drugs on death-response, it may be said that the displacement of the rigor-point varies with the tonic condition of the tissue, the nature of the drug, and the strength of the solution. Out of several possible cases, I shall here give only a few simple instances.

Duplication of rigor-points.—One very curious effect of certain chemical reagents, such as ether, lies in the exhibition of two distinct points of rigor, instead, as normally, of one. This effect is very easily seen, in the spasmodic death response of *Mimosa*. We take a specimen, and subject it to continuous rise of temperature, in water, which contains a small quantity of ether. It will be remembered that, under normal conditions, the first down movement of the single composite spasm of death-response took place in young leaves at an average temperature of 59.5° C., the second

upward movement being at 61.7° C. Under ether, however, we have the peculiar phenomenon of two composite spasms separated by an average interval of about 27° C. This effect will be understood from the following table, which gives the results obtained with two different specimens, B and C, the specimen A being heated in water without ether, and thus constituted a standard.

TABLE SHOWING DUPLICATION OF RIGOR BY ETHER

Specimen	Preliminary Spasm		Final Spasm	
	Fall	Erection	Fall	Erection
Under normal conditions A { Leaf (1) young . Leaf (2) older .	Absent Absent	Absent Absent	59° C. 60° C.	61.5° C. 62° C.
After application of ether B { Leaf (1) young . Leaf (2) older .	31° C. 32° C.	37° C. 38° C.	59.5° C. 60° C.	61.5° C. 62.5° C.
After application of ether C { Leaf (1) young . Leaf (2) older .	32° C. 33° C.	39° C. 40° C.	58.5° C. 59° C.	62.5° C. 64° C.

Another table is here given, showing the results obtained when the water contained a small quantity of hydrochloric acid.

EFFECT OF HYDROCHLORIC ACID

Specimen	Preliminary Spasm		Final Spasm	
	Fall	Erection	Fall	Erection
Leaf (1) . . .	29.5° C.	31° C.	63° C.	66.2° C.
Leaf (2) . . .	29.8° C.	31.5° C.	63° C.	66.8° C.

From these results several interesting observations arise, the most striking of which is the occurrence of the preliminary spasm itself, separated by so large an interval from the final death-response. This duplication of the rigor-point

is not a distinctive effect of the action of anæsthetics as such, since hydrochloric acid and various other chemical reagents give a similar result. It would be premature to pronounce on the significance of this very suggestive phenomenon.

A plausible suggestion, which offers itself, is that the approach of molecular rigidity concomitant with death, which here appears imminent by the action of the reagent, as seen in the preliminary spasm, is tided over, or counteracted, by the molecular mobility conferred on the tissue, through the rising temperature of the bath. Should this inference prove to be correct, these experiments might throw an interesting light on an ancient practice, still current in India amongst an old class of quack-doctors, by which cases of snake-bite are said to be cured, under a treatment whose essential feature is the application of hot water and steam, with accessory incantations! The same principle may also be the basis of the alleged hot-water and steam cures of more modern practitioners.

The duplication of the rigor-point by the action of ether is also noticeable in the thermo-mechanical curve given by a radial organ. Thus, in a curve given by the style of *Datura*, the preliminary rigor-point was found to be at 36.5° C., the second being at 53° C.

As has been said, the effect produced by various poisonous reagents depends on the tonic condition of the tissue, as well as on the nature of the drug. In those cases in which the rigor is not duplicated, there is a translocation of the death-point, which, as far as I have yet seen, is invariably lowered. Thus, in an experiment already described with the style of *Datura*, I found this translocation, under the action of dilute copper sulphate solution, to be from the normal 60° to 57° C.

Death-response not due to coagulation.—From the experiments which have been described, it is evident that the death-response, like other modes of excitatory response, is appropriately modified by all those influences which affect

the physiological condition of the tissue. The rigor of spasmodic contraction at death is, therefore, not to be regarded as due to any coagulative action. And, indeed, the theory of a connection between rigor and coagulation is now generally discredited.¹

By the methods described, then, it is possible to study the effect of various agencies in the modification of death-response : in the case of anisotropic organs, by observation of their lateral responsive movements, and in that of radial organs, by the translocation of the point of inversion. I was next desirous of discovering some still simpler means of determining the effects of various conditions in a qualitative manner. This might be accomplished if we had a number of organs exactly similar to one another, which would give some unmistakable sign of death-response, at the point of occurrence, either immediately, or at some definite interval afterwards. A certain number of these organs might then be taken as standard, and the others subjected to the action of various modifying influences. Any differences between the temperatures concomitant with *post-mortem* symptoms would now indicate the modifications produced by these agents.

In a certain sense, such an experiment may be carried out with a number of leaves on the same plant of *Mimosa*. But in such a case the organs to be compared are not very numerous, and different leaves of exactly the same age cannot be secured.

Death-response in flowers.—This led me to investigate whether, amongst flowers, specimens could be obtained which would exhibit a death-movement at the critical temperature.

¹ 'The causes which determine the varying resistance of different plants to heat are quite unknown. The fact that a temperature of from 20° C. to 40° C. kills certain plants, shows that in their case death is not the result of coagulation of the plant-albumin. Further, some plants grow at 75° C., *i.e.* above the temperature at which egg-albumin coagulates. Coagulation need not always occur, for we must remember that the acid and alkali albumins are not coagulated by heat.'—Pfeffer, *Physiology of Plants*, English edition, 1903, vol. ii. p. 230.

And I found that many flowers did so in a marked degree. Thus, for example, in two different specimens of *Convolvulus*, both full-blown, the flower being subjected to rising temperature, the corolla-bell folded up at exactly 62.5° C.

We thus see the possibility of obtaining flowers which, having had the same previous history, are likely to exhibit the death-movement more or less at the same point. I thought that such a collection of similar specimens might probably be obtained in a small space, from the capitulum of a composite flower, and as a matter of fact I succeeded in finding several. The nature of the movement, whether up or down, and its more or less pronounced character, appeared to depend in these cases on the age of the flower.

In connection with this question, we must remember that in flowers, as in leaves, we may have in a single specimen alternating hyponastic and epinastic growths. It is therefore conceivable that the death-movements of old and young flowers may take place in different directions, and that at some stages there may be little or no motion of any kind. However this may be, I have found that in the double Indian marigold at the temperature of 62.5° C. the florets arranged themselves in two groups, the outer and lower whorls turning down, and the younger or central whorls rising up, at the critical temperature. In the case of some of the large garden daisies, yellow and white, I found the critical temperatures to lie between 61.5° C. and 63° C., the death-movement consisting of a folding up in some cases, and a curving down in others. If the flower have been subjected to uniform illumination on all sides, then the movement of all the florets will take place within a degree or so. In the French marigold, grown in India, the florets of the ray fold up, at from 59° C. to 60° C. From these experiments we see that, the death-point for all the flowers on the same capitulum being about the same, it might be possible to treat one-half of the florets of a single flower-head as normal or standard, while using the rest for comparative study on the influence of various agencies.

Method of thermographs of regional death.—But I have found out another and distinct method for detecting the effects of various agencies. And this method is not only very interesting in itself, but it enables other obscure problems to be attacked in a satisfactory manner. It depends on the taking of Thermographs of Regional Death.

It is known that amongst the symptoms which occur at some indefinite interval after death is that of discoloration. Although this phenomenon is not concomitant with death, yet the temperature-interval between the two can in many cases be rendered definite. Thus for example, when the blue *Convolvulus* is subjected to rising temperature at the normal rate, it shows death-movement at 62.5° C. But there is as yet no sign of discoloration. When the temperature, however, rises to 70° C. the heating water begins to undergo discoloration from the escaping cell sap. It would appear probable, from various experiments which I have carried out, that discoloration does not begin at the point of death-contraction, but occurs at or about the point of the subsequent relaxation. But in the case of *Convolvulus* there is no striking change seen in the flower itself, for the loss of colouring matter is gradual. In the style of *Datura alba*, however, we have a more definite change of colour. This organ, from being milk-white, becomes brown at a temperature of 64° C., that is to say, 4° above the death-point, when the temperature of the bath is rising at the ordinary rate. In the petals of *Sesbania coccineum*, again, under similar conditions, the change of colour is very striking. Rich crimson here turns into pale blue, at a fairly definite temperature of 67° C. The most marked and easily observed of all these changes is seen, however, in the mauve petals of *Passiflora quadrangularis*, which normally becomes colourless at a temperature of 70° C. The filamentous corona of the same flower again, in which the filaments are barred by purple rings at intervals, loses its colour normally at 68° C. The death-point of these filaments is, it should be remembered, 60° C. We thus find on raising the temperature

in each of these cases, at the standard rate of 1° per 1.5 minute, that not only is there a definite death-point, evidenced by sudden contraction, but that the discoloration-point is separated from this, by a definite temperature-interval. And since we have found the death-point to be translocated by the influence of various agencies, we may expect the discoloration-point also to be displaced, in a similar manner, under the same conditions.

Development of thermographs.—This being so, it ought to be possible to 'develop' images of local death. We take a coloured petal, say of *Passiflora*, and placing two circular electrodes diametrically opposite to each other, with the petal between, pass tetanising shocks, which are of sufficient intensity to fatigue, but not to kill, the tissue. When the electrodes are removed, there is nothing by which the eye may distinguish the zone of fatigue. In order now to develop this invisible picture, we have simply to subject the specimen to the ordinary bath, with rising temperature. For we have seen, from experiments already described, that the power of the tissue to resist death is lowered by fatigue. In the case of the present specimen, therefore, the fatigued area will die, and undergo subsequent discoloration, earlier than the rest of the petal. In carrying out this experiment, the area of fatigue was found developed as a white image on a purple background, at a temperature of 45° C. It should be remembered that, as said before, the lowering of the death-point varies with the amount of the fatigue; hence the point of discoloration may be found as low as 40° C. or as high as 50° C. and upwards. If the petal be removed from the bath as soon as development begins, the image will remain. But if it be maintained under the rising temperature, the thermograph will vanish, with the death and discoloration of the background.

Again, I took two similar styles of *Datura*. One of these I kept as standard, and passed tetanising shocks through the other. On subjecting both to rising temperature in a single

bath, the fatigued style underwent the change from white to brown at 56° C., whereas the test specimen was not discoloured until 64° C.

Determination by thermographic method of relative excitatory effects of anode and kathode.—This thermographic method also enables us to attempt the solution of other recondite problems, such as that of the relative excitatory effects of the anode and kathode. It will be shown in the next chapter that when the electromotive force is not too excessive, it is the kathode which causes excitation when the circuit is made or completed. This fact will be demonstrated there by experiments undertaken with sensitive plants, in which the excitatory effect is indicated by the mechanical response of the motile leaflets. No such means is available, however, in the case of ordinary, or so-called non-sensitive, tissues. In such cases, therefore, I shall undertake to demonstrate the same fact, but by means of death-response.

We have seen that a tissue which has already been excited, is more fatigued than one which has not, and a fatigued tissue is, as we have seen, subject to death, and subsequent discoloration, at lower temperatures than the unfatigued. Hence, if excitation be caused in the cathodic region at make, death-discoloration ought to occur there earlier than in the anodic. This I have been able to demonstrate in the following manner: I took two similar petals, or two halves of the same petal, of *Passiflora*. The two were held side by side in a glass vessel full of water, at a distance of 3 cm. from each other, the temperature being gradually raised. When the temperature is about 50° C. a current is sent from a battery so that it enters by one petal, and leaves by the other. It is now found that the discoloration of death takes place earlier at the kathode than at the anode. The value of the difference is about 4° C. I carried out this experiment on the petals of the crimson *Sesbania coccineum* also.

TABLE SHOWING EFFECT OF ELECTROTONUS ON DEATH-POINT

Specimen	Temperature of Discoloration	
	Anode	Kathode
1. Petal of <i>Passiflora</i>	63° C.	59° C.
2. Filament of <i>Passiflora</i>	60° C.	56° C.
3. Petal of <i>Sesbania</i>	64° C.	61 °C.

The effect here described takes place, as has been said, where the electromotive force is not excessive. Under these conditions, it is the kathode which is the more excitable. I have, however, discovered a very curious case of inversion of excitation which occurs when the E.M.F. exceeds a certain value. With high electromotive force, then, it is the anode which excites at make of the circuit. The demonstration of this fact by means of mechanical response, and subsidiary proof by means of death-response, will be given in detail in a subsequent chapter.

SUMMARY

The death-point is lowered by fatigue, the amount of lowering depending on the intensity of fatigue.

The characteristic thermo-mechanical curve is modified and the point of inversion translocated by the action of chemical reagents.

Certain reagents produce a duplication of the rigor-point.

The death-point is translocated to a temperature lower than normal by the action of poisonous reagents.

Under standard conditions, there is a definite interval between the death point and discoloration-point of vegetable tissue.

Hence it is possible to obtain thermographs of localised effects of various agents.

The excitatory effect of kathode is demonstrated by the earlier discoloration produced there.

PART III
EXCITABILITY AND CONDUCTIVITY

CHAPTER XVI

ON EXCITATORY POLAR EFFECTS OF CURRENTS

Hydro-mechanical theory of excitation in plants—Theory of protoplasmic change—Crucial tests applied by means of polar excitation—Mono-polar and Bi-polar methods of excitation—Advantages of study of polar excitation in plant-tissues as compared with animal—Effects of feeble E. M. F.—Effect of moderately high E. M. F.—Experiments with highly excitable tissues.

HAVING observed, by means of mechanical responses, the various excitatory effects which are caused in plants by stimulation, and the influence of different agencies in modifying these excitatory effects, it is now desirable to make an inquiry into the manner in which excitation takes place, and into the method by which it is transmitted to a distance. There has been a great deal of uncertainty regarding this subject, and the prevailing view is that which holds the transmission of excitation to be due to the propagation of hydrostatic disturbance.

Mechanical theory.—According to this theory, it is supposed that stimulus causes a mechanical disturbance, bringing about an alteration of the hydrostatic equilibrium. The propagation of excitation in plants is thus regarded as nothing more than the transmission of this hydro-mechanical disturbance.

We know, however, that the transmission of hydrostatic disturbance takes place with relatively great rapidity, while these excitatory effects in the case of plants travel sometimes as slowly as 1 mm. or less per second. I have shown, moreover, that its responses, both mechanical and electrical, are profoundly modified by the physiological condition of the plant. There is, for example, an optimum temperature at which response is at a maximum, any change, whether above

or below, inducing depression. Anæsthetics, moreover, temporarily, and poisons permanently, abolish response. It will be shown further, in Chapter XVIII, that the transmission of excitation may be very much diminished, or even arrested, by the application of cold or ether.

Theory of protoplasmic change.—It is thus seen that the hydro-mechanical theory is incapable of explaining the facts of the case. I shall now, therefore, proceed to demonstrate that the excitatory change in plants is brought about in the same manner as in animals, and that the transmission of excitation depends upon the propagation of protoplasmic changes, in the one case as in the other. This may be determined by a crucial experiment as to whether vegetable tissue exhibits those peculiar polar effects of the electric current on excitability, which are seen in the protoplasm of animal tissues. In the animal tissue, for example, it is the kathode that, under normal conditions, produces excitation, the effect of the anode being the reverse. In the case of animal tissues, again, the anode will even act as a block to the transmission of stimulus.

Crucial tests applied by means of polar excitation.—Such effects are incapable of explanation by the hydro-mechanical theory, and if we succeed in discovering similar phenomena in the case of vegetable tissues, we shall establish the existence of a fundamental property of protoplasm common to the animal and vegetable alike. With this end in view I have carried out numerous experiments on plants, both sensitive and ordinary. As specimens of the former class, I used *Biophytum*, *Mimosa*, and *Averrhoa*. The investigation resolves itself into the determination of the differences of excitatory effects, at the anode and kathode, both at make when the circuit is completed, and at break when it is interrupted. The presence of the excitatory effect is indicated in the case of 'sensitive' plants by the mechanical responses of the motile organ. In order to separate the effects of the anode and kathode, we may use the *Mono-polar* method, *i.e.* have one electrode near a motile organ, and the

other very distant from it (fig. 89). If the plant is not very excitable the effect produced at the distant point will not reach the motile organ, and we shall obtain the isolated effect of a particular electrode. Again, if we wish to observe the effects at both the electrodes simultaneously, we may employ the *Bi-polar* method, in which both electrodes will be placed at or near the motile organs. The most suitable means for the application of electrical stimulus will be either a constant electrical current from a voltaic battery, or the discharge from a charged condenser.

We have again to study the respective effects of feeble, moderate, and excessively strong electromotive forces.

In experimenting on polar excitation in animal tissues, a nerve-and-muscle preparation is generally used, the excitation of the nerve being studied by means of the indication given by the terminal motile organ, the muscle. On the other hand, experimenting on *Biophytum* for instance, the petiole acts as the conductor of stimulus, and is provided with—not a single terminal motile organ, but—a number of lateral motile organs, viz. the ‘sensitive’ lateral leaflets. The analogous case in animal tissue would be a hypothetical nerve, provided with a hypothetical series of contractile muscles attached to it laterally. The relative advantage possessed by such a vegetable organ is, that the changes in the excitabilities, throughout every portion of the excitable conducting tissue, are visibly manifested.

I experimented altogether on some hundreds of specimens. Some of these were very sensitive; others only moderately so. The results under normal conditions were perfectly consistent. As it would entail much mere repetition to relate every one of these experiments, I shall here give only typical instances in detail. While I was studying the effect of the establishment or cessation of a constant current I made a practice—whenever the leaves or leaflets recovered within a moderate time from the effects of the stimulus of a current flowing in one direction—of trying a second experiment on the same plant, by reversing the direction of the current, so

that in the reversal experiment, what was formerly anode became kathode, and *vice versa*.

In this way corroborative reversal effects were obtained. In experiments with condensers it was not necessary, in order to reverse the electrodes, to reverse the battery connection, for owing to the special arrangements of the electric circuit (fig. 14) the anode at 'charge' became kathode at 'discharge.'

In studying the effects of increasing intensity, in the case of constant current, I simply add to the number of storage cells, and in this way obtain increasing voltage. The strength of the condenser discharge is increased by increasing the voltage of the charging circuit. With the same tissue, where the resistance is constant, the current increases with the acting E.M.F. Hence, increasing E.M.F. here connotes also increasing current. But we may have a very high E.M.F. and, owing to high resistance of the tissue, only a feeble current. From the trend of the various experiments that I have carried out, it would appear that the characteristic polar effects are determined more by the intensity of the E.M.F. than by that of the current. In the case of the present investigation, as we must also bear in mind, the experiments were performed with many different specimens, the excitability of some being greater than that of others.

Effect of feeble E.M.F.—The first experiments of this series were carried out by the method of mono-polar excitation. The first specimen employed was *Mimosa*, one electrode, the kathode, being connected with the pulvinus, and the anode, at some distance, with the main stem. The electromotive force used was ten volts. The leaf-stalk fell at make of the circuit. The leaf was found to recover, after a due interval, during the continuation of the current. The current was now broken, but this produced no responsive effect whatsoever. The current was next reversed, the pulvinus being made anode. But this anode-make did not produce any excitatory effect, neither did the succeeding anode-break. From these experiments we see (*a*) that a feeble E.M.F. excites at the kathode at make; (*b*) that the excitation takes

place during the variation of current, but not when the current has attained a constant value ; and (c) that there is no excitation at either kathode-break or anode-make or break.

I next used a specimen of *Biophytum*, the E.M.F. employed being eight volts. The kathode was at first at the lower end of the leaflets, the anode being on the main stem (fig. 89). At make there was an excitatory wave at the kathode. This travelled outwards and produced depression of four pairs of leaflets. On reversing the current, the new anode did not produce any effect at make, nor did its break produce any excitation. It will be shown presently that it is necessary to have a certain moderate intensity of current in order that the anode-break may cause excitation.

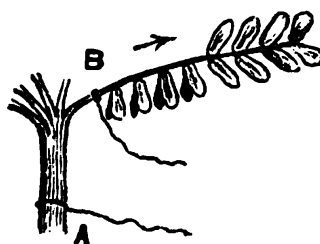

FIG. 89. Diagrammatic representation of Mono-polar Excitation

B was kathode, which at make gave rise to excitatory wave, causing depression of four pairs of leaflets. The electric connections are always made with non-polarisable electrodes.

The effect on *Biophytum* of a continuous current at the kathode is to bring about a more or less prolonged 'contraction,' the period of recovery being thereby much protracted. With the leaf-stalks of *Mimosa*, however, the effect is not so marked. With this plant, nevertheless, I have been able to observe certain antagonistic effects of anodic and cathodic actions ; that is to say, while there is slow recovery from cathodic contraction, on reversing the current, there is often an impulse of relaxation, the recovery being thereby suddenly hastened. But it must be understood that these particular effects are liable to modification, being dependent on the physiological condition of the tissue.

I next repeated these experiments on the effect of feeble E.M.F. producing excitation by means of condenser discharge. The results obtained were precisely the same as with constant current. That is to say, with relatively feeble charge, the excitation took place at the kathode at make, and not at the anode. The great advantage of excitation by the method of condenser discharge is, that the total

O

quantity of electricity passing through the tissue is very small, and the changes produced in the substance of the specimen are therefore slight.

The next group of experiments was carried out by the bi-polar method of excitation, which enables us to make simultaneous observations of the effects at anode and kathode. As

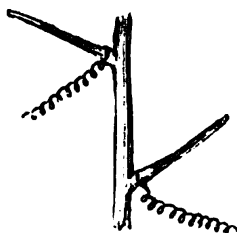

FIG. 90. Bi-polar Excitation of *Mimosa*

in the previous cases, the specimen used for the first experiment was *Mimosa*, the E.M.F. employed being twelve volts. Connections were made with the pulvini of two neighbouring leaves (fig. 90). On make, the kathodic leaf-stalk fell; there was no action at the anode. At break, there was no action. On now reversing the electrodes and making the anode kathode, the leaf-stalk which had not previously responded fell under kathodic excitation. There was no effect on the anodic leaf-stalk, nor was there any effect on either at break.

For the succeeding experiment I used a leaf of *Biophytum* and an E.M.F. of eight volts, the electrical connections being as shown in the diagram (fig. 91). On

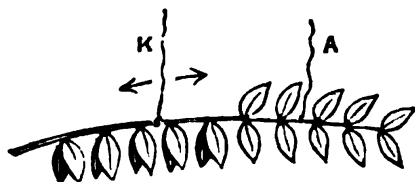

FIG. 91. Bi-polar Excitation of *Biophytum*

At make an excitatory wave proceeded in two directions from kathode, but none from anode.

completing the circuit, the excitation was discharged at the kathode, and the wave proceeded in both directions from the kathodic point, three pairs of leaflets being depressed towards the stem and two in the interpolar region.

There was no effect at break at either electrode. On reversal, the new kathode, formerly the anode, became the point of excitation, as evidenced by the depression of contiguous leaflets.

Similar results were obtained when excitation was produced by condenser discharge. Thus with a condenser having a capacity of .01 microfarad, charged to eight volts,

response was observed at the kathode at charge. The excitatory wave travelled in both directions, and five pairs of leaflets were depressed. There was no effect at the anode. At discharge, the former anode became kathode, and there was a responsive movement of the leaflets near that point.

In the following table, the characteristic polar effects of feeble E.M.F. may be seen at a glance.

TABLE SHOWING THE POLAR EFFECTS OF FEEBLE E.M.F.

Kathode		Anode	
Make	Break	Make	Break
Response	No response	No response	No response

Effects of moderate E.M.F.—From this point onwards it will be found sufficient to describe the results obtained by means of the bi-polar method of excitation, this mode of investigation being more complete than the mono-polar.

With regard to the first of these, a number of experiments were performed on a single specimen of *Biophytum*, using an E.M.F. of 24 volts. The excitatory wave at make was found to be initiated at kathode, and to travel in both directions, causing the depression of nine pairs of

leaflets. The forward half of this wave of excitation only stopped at one pair of leaflets before the anode (fig. 92). This,

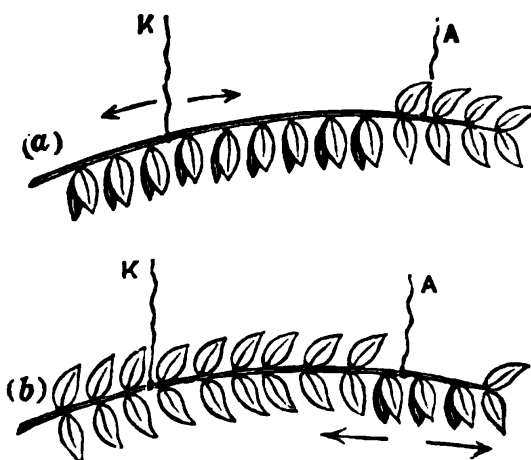

FIG. 92. Make-kathode and Break-anode Effects in *Biophytum*

(a) Shows effect at make, excitation being produced at kathode; (b) shows effect at break, excitation being now produced at anode.

as will be seen later, is due to the depressing action of a strong anode. There was no action at the anode itself at make ; at break, there was no action near the kathode, but there was excitation at the anode, as was shown by the fall of three contiguous pairs of leaflets. The direction of the current was now changed, the poles being thus reversed, and eight pairs of leaflets fell at the new kathode, in and out. There was, however, no effect at the new anode at make ; but at break, the reverse was the case, leaflets falling near the anode, and no response occurring at the kathode. This experiment was repeated three times on the same specimen, and the results were in every case similar. I give (fig. 93) a pair of records

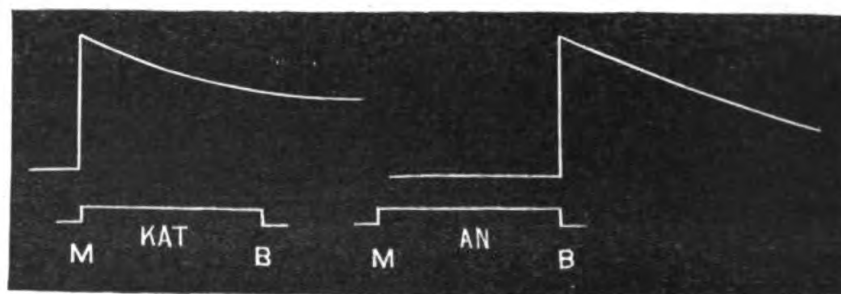

FIG. 93. Records of Responses of Leaflet of *Biophytum*, showing Responses occurring at Kathode at Make and not at Break ; and at Anode at Break and not at Make

in *Biophytum* leaflet, showing the opposite character of the effects of make and break at the anode and kathode respectively. The E.M.F. used in this particular experiment was sixteen volts.

In the former series of experiments, it was seen that there was no break-anode effect when the E.M.F. was feeble. The present experiments show us that the break-anode is effective when the E.M.F. is moderately strong.

I obtained similar effects when stimulation was produced by means of condenser discharge, the experiments being carried out on *Biophytum*.

From the investigation just described, it will be seen that with moderate E.M.F. we obtain response from the

kathode at make, and from anode at break. The following tabular statement exhibits these various effects in a concise form.

TABLE SHOWING EFFECTS OF MODERATE E.M.F.

Kathode		Anode	
Make	Break	Make	Break
Response	No response	No response	Response

Experiments with highly excitable tissues.—In experimenting on the polar excitation of animal tissues, using a nerve-and-muscle preparation, it is found that when the proximal end of the nerve is made kathode, that is to say,

when the current is ascending, the indicating muscle shows response. This is due to the make action of the kathode. At break also response occurs; but this is due to the transmitted action of the break excitation of the distant anode. When the current is reversed, that is to say, made to descend, there is also response, due to the make excitation of the distant kathode.

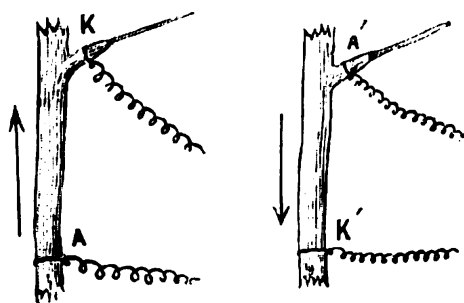

FIG. 94. Effects of Ascending and Descending Currents, on Highly Excitable Specimen of *Mimosa*

In the figure to the left, the anode is below and kathode above, and current ascending. In the figure to the right, the kathode below, anode above, and current descending.

When the current is broken, response takes place again, in consequence of the break of the proximal anode. All these cases are rendered possible by the high conducting power of the intervening tissue, the nerve.

I have been able to obtain precisely similar results, by selecting very highly excitable specimens of *Mimosa*. One electrode was placed at the junction of stem and petiole, the

second being at a distance of about 3 cm. lower on the stem. In this case the stem, or certain of its elements, acted as the conducting nerve, the leaf serving as the terminal indicator (fig. 94). With such an arrangement, using a plant of exceptionally high excitability, and E.M.F. of moderate intensity, I have obtained the following results :

1. *Current ascending (a)*.—At make, the leaf-stalk fell. This was due to the direct make action at the kathode (*b*). At break there was also a response. This was due to the transmitted break-anode excitation reaching the leaf-stalk.

2. *Current descending (a)*.—At make, the excitation of the distant kathode reached the leaf-stalk, the current at the anode not being sufficiently strong to act as an effective block. (*b*) At the stoppage of the current, there was another response of the leaf-stalk. This was due to the break effect of the anode in the immediate vicinity.

The following tabular statement shows at a glance the effects which are apparent at the terminal organ :

TABLE SHOWING THE EFFECT OF MODERATE E.M.F. ON HIGHLY EXCITABLE MIMOSA

Ascending		Descending	
Make	Break	Make	Break
Response	Response	Response	Response

The experiments described above show that the excitation produced in plant-tissues by an electrical current is not indiscriminate, but selective, or polar, in its action. The effects seen here are of precisely the same nature as those observed in animal tissues. The exhibition of such polar effects completely disproves the hydro-mechanical theory of excitation in plants. They point unmistakably, on the other hand, to the existence of some fundamental property of protoplasm, common to animal and vegetable alike, which under normal conditions finds an identical expression in the two, of cathodic excitation at make, and anodic at break.

SUMMARY

Polar effects are observed in plants in every way similar to those obtained from animal tissues. The laws of polar excitation in plants are as follows :

A. **With feeble E.M.F. the kathode excites at make, and not at break. The anode excites at neither make nor break.**

B. **With moderately strong E.M.F. the kathode excites at make, and not at break. The anode excites at break, and not at make.**

CHAPTER XVII

ON CONDITIONS OF REVERSAL OF NORMAL POLAR EFFECTS IN LIVING TISSUES

Effect of high E.M.F.—Effects at two stages, *A* and *B*—Experimental verification of *A* stage effect—Similar effects seen in protozoa—Experimental verification of complete reversal at *B* stage—Law of polar effects under high E. M. F.—Investigation on polar effects by death-response—Reversal of polar effects as due to fatigue, or tissue-modification—Investigation of polar effects by glow-response of fireflies.

THE phenomena of polar excitation which have been observed in animal tissues are summarised in the formula which is known as Pflüger's Law, viz. that excitation takes place at the kathode at make, and the anode at break. It has been found, however, by Kühne, Verworn, and others, that in the case of the protozoa the polar effects are exactly the opposite; that is to say, in these instances, it is the anode which excites at make. The inference has hence been drawn, that Pflüger's law was inapplicable in the case of unfibrillated protoplasm.

That this assumption, however, is incorrect, I have already shown, by the fact that the undifferentiated protoplasm of the plant-body gives rise to polar effects which are in every way identical with the normal polar effects seen in animal tissues.

It occurred to me that the study of polar effects in plants might throw some light on this anomaly, and that I might thus be able to trace out the stages by which the one effect was gradually transformed into the other, determining further the conditions which were effective in predisposing a tissue towards this reversal.

Effect of high E.M.F.—In carrying out this investigation,

I soon discovered that the value of the acting electromotive force had an important influence on polar excitation. I found that under an increasing E.M.F. the excitation produced at the kathode underwent, first an increase, and then, on reaching a maximum, a decrease, which might even become negative. The changes produced at the same time at the anode were exactly the opposite. There was thus a progressive variation, resulting in an exchange of the excitatory properties of the anode and kathode.

My first observation with regard to this question was made in the course of my investigations on the determination of the velocity of transmission of excitation (Chapter XX.), and on the effect of increasing intensity of stimulation on this velocity. I found that, using for instance thermal stimulation, when this was strong, it was transmitted with a greater velocity than when it was feeble. Hence the speed with which the effect of stimulus travels in a given tissue may be held to afford a measure of the effective intensity of the stimulus. In order, however, to apply a stimulus which might be increased by known amounts, I next tried the electric mode of stimulation, expecting to produce an increasingly effective intensity of stimulus by increasing the E.M.F., excitation being produced at the kathode at make. In the course of a particular experiment, on a leaf of *Biophytum*, I found that as the E.M.F. was augmented from eight to thirty-two volts, the excitatory value of kathode at make was also increased, as shown by the fact that the velocity of the transmission of excitation was raised from 3.27 mm. per second, in the former case, to 3.83 mm. in the latter, an increase, that is to say, of 17 per cent.

But on raising the E.M.F. still higher, I found that the velocity of transmission from this point underwent a progressive decrease. From this it would appear that the excitatory effect of the kathode at make had an optimum value, in this case of thirty-two volts, beyond which there was a decline. This optimum value would naturally undergo a certain variation with the nature and condition of the tissue. Now, as the

excitatory power of the kathode at make is seen to undergo a gradual diminution, beyond this optimum, it follows that at some certain high E.M.F. the excitation produced by it would be zero. In other words, the kathode would cease to excite.

Possibility of two distinct stages of reversal, *A* and *B*.

Further, since the effects at anode and kathode are, generally speaking, contrary in character, we might expect a corresponding change, but of opposite nature, to make its appearance progressively at the anode. In other words, it might happen that at a certain stage in the raising of the E.M.F. the exciting value of the kathode would be considerably diminished, and that the anode would begin to show excitatory effect. This might be designated as the *A* stage.

On still further raising the E.M.F. the same contrary-directioned change might be expected to continue progressively at the anode and kathode, and to reach a stage at and beyond which it would be the anode which excited at make, while the kathode produced either no excitation or actual depression. This might be designated as the *B* stage. We should then have a complete reversal of the normal polar effects.

If we exhibit these inferences, as to the relative excitatory powers of anode and kathode with increasing E.M.F., by means of curves, whose abscissæ represent the E.M.F. while their ordinates give the corresponding excitatory values, the kathode curve would first rise to a maximum, and then fall continuously, till, reaching the zero line, it might even proceed still further in the negative direction, thus representing depression. The anodic curve, on the contrary, would at first descend in the negative direction, thus indicating increasing depression of excitability, until it reached a negative maximum, after which there would be a reversal, and it would begin to ascend and reach the zero-line. Here the anode would cease to depress. After this it would proceed upwards in the positive direction, indicating a continuously increasing power of excitation. The anodic and cathodic curves in the course of this ascent would cross at a

certain point, indicating that both of them now excited in about equal degrees. This would constitute the *A* stage. Beyond this would be the *B* stage, where the anode alone would excite.

I now proceeded to subject these theoretical inferences to the experimental test. The special difficulty of this investigation lies in the fact that it is necessary to discriminate the direct from the transmitted effect at the two electrodes, with absolute certainty. For if the two points be not at a sufficient distance, and if the conductivity of the intervening tissue be great, the true effect of one electrode may be rapidly transmitted, and appear at the other. For these reasons, the plant *Biophytum* is not in this case a very suitable subject for experiment, its conductivity being great, and its opposite leaves not at a sufficient distance from each other. *Mimosa*, however, may be made to serve the purpose, for, though its conductivity is great, it is possible to select two leaves on different branches of the same plant which are very far apart. The plant *Averrhoa* is also appropriate, its conducting power being relatively slight. Electrical connections may, in this case, also be made with opposite leaves widely apart. In the case of *Mimosa* the excitatory effect is made visible by the fall of the leaf, in the case of *Averrhoa* by the depression of the leaflets. It is thus possible to render the effect of the two electrodes mutually distinct. It is also possible to distinguish the transmitted excitation, if any, by the serial depression of the intervening leaves or leaflets during the passage of the wave of excitation.

As these excitatory effects are dependent on the physiological condition of the tissue, we should expect that the E.M.F. which produces reversal would vary with different plants and their physiological conditions. The highest constant E.M.F. available for my own investigations was 220 volts, that being the pressure in the street-mains. I therefore hoped that I might be fortunate enough to find plants in a state to exhibit the expected reversal within this value. I shall now proceed to describe actual experiments with various

plants, and first I shall take those in which the *A* stage was exhibited, that is to say, those in which the anode as well as the kathode showed excitation at make.

Experimental verification of *A* stage effects.—With the plant *Biophytum*, I have always found, without exception, that up to thirty-two volts, or thereabouts, the polar effect was normal ; that is to say, excitation was produced at the kathode at make and not at the anode. On using an E.M.F. of forty-eight volts, however, with a certain specimen, I obtained excitatory response at make, at both anode and kathode. That this anodic effect was not due to transmission of excitation from the kathode, was seen in the fact that some of the interpolar leaflets were not affected, as all would have been had the wave of excitation passed from kathode to anode.

I shall next describe experiments made on *Mimosa*, in which, as has been said, the two electrodes can be separated by a longer tract of tissue. In the case of this plant, the value of the E.M.F. which is required to bring on the *A* stage effect, is much higher than in *Biophytum*. I have occasionally obtained it with 110, but more usually with 220 volts. In order to show how at this stage the anodic and cathodic effects tend to become interchangeable, I shall describe three experiments.

In the first of these, an E.M.F. of 110 volts was used. At make, the cathodic leaflets fell energetically, while the anodic fell but slightly, and after a little delay. Here we see that though reversal is setting in, yet the normal cathodic effect is relatively predominant.

In the second of these experiments, I used 220 volts. The anodic fall now took place slightly earlier than the cathodic. The current was maintained till the leaflets recovered. On now breaking the circuit, there was a slight anode-break excitation, but none at the kathode. In this case, though from the slight priority of the anodic excitation we infer some predominance of the anode, yet the fact that the effect at break is normal shows that we are still in the

transition stage. In the next experiment, the tendency to reversal will be shown to have become predominant.

In this third experiment with another specimen, an E.M.F. of 220 volts was again used. At make, there was an immediate energetic fall of the anodic leaflet, while that at the kathode was slight, and delayed for some time. At break, moreover, there was no effect on the anode, and a slight and delayed excitatory effect was distinctly perceptible at the kathode. From this we see that the anode is now appropriating the normal action of the kathode, and *vice versa*, reversal having set in unmistakably.

Reversed action in protozoa.—These experiments will probably be found to explain the assumed anomaly in the case of protozoa. In experimenting on *Actinosphaerium*, for example, Verworn found that 'at closure of the current in the first place, the pseudopodia, both on the anodic and kathodic side of the globular body, become varicose and begin to contract. If the circuit be opened the pseudopods on the kathodic side become varicose in about the same degree as had taken place immediately after the closure of the circuit.'¹ In this experiment, where both anode and kathode exhibit excitation at make and only the kathode at break, we have a case exactly parallel to that of the third experiment with *Mimosa*, which has just been described. That, as in the case of plant-tissues, a fairly high E.M.F. was instrumental in producing reversal appears probable, from the fact that it is specially mentioned in the account of the experiment, that 'in consequence of the high resistance in the circuit, a comparatively high E.M.F. had to be used.'

Experimental verification of B stage effect.—I could not obtain with *Mimosa* at 220 volts complete cessation of excitation at the kathode at make, but I succeeded in doing so with *Averrhoa*, in the autumn and winter seasons. With this plant, I observed all these A stage effects, which have already been described in the case of *Mimosa*; and that of completed reversal, or the B stage effect, was obtained in

¹ Biedermann, *Electro-Physiology*, English edition, 1896, vol. i. p. 302.

more than a dozen instances, out of which I shall give an account of two.

In the first of these, the two electric contacts were made on the same leaf, at a distance of 5 cm. from each other. At make, using an E.M.F. of 220 volts, excitation was produced at the anode only, and the depression of successive leaflets proceeded towards the kathode, but was arrested at one pair in advance of that point, the kathode apparently acting here as a depressor.

In the second experiment, the electric contacts were made at a great distance from each other, with middle points of two opposite leaves. At make, excitation was produced at the anode only. At break, however, it took place at the kathode and not at the anode. We have here a complete reversal of the normal polar effects under the action of very high E.M.F.

The following tabular statements show at a glance the polar effects at both *A* and *B* stages, under a high E.M.F. :

TABLE SHOWING EFFECT OF HIGH E.M.F.—*A* Stage.

Kathode		Anode	
Make	Break	Make	Break
Moderate response	Occasional response	Moderate response	Occasional response

TABLE SHOWING EFFECT OF EXCESSIVELY HIGH E.M.F.—*B* Stage.

Kathode		Anode	
Make	Break	Make	Break
No response	Response	Strong response	No response

Law of polar effects under high E.M.F.—We have now traced out that process of continuous change by which under a gradually increasing E.M.F. there is produced a reversal of normal polar effects, and we thus arrive at the following law of polar excitation :

Under high E.M.F.—at the *A* stage—both anode and kathode excite at make; at break there is occasional excitation at either anode or kathode. Under excessively high E.M.F.—at the *B* stage—the anode excites at make and the kathode at break.

Without this addition the law of polar excitation is incomplete; and I shall have occasion, in my work on the Electro-Physiology of Plants, to show its application in explaining certain excitatory electromotive phenomena which would otherwise have remained obscure.

Investigation on polar effects by death-response.—I have already explained in Chapter XV. that the death-point of an excited tissue is lowered below the normal. This made it possible to devise a test by whose means it might be determined which of the two electrodes produced excitation. Thus, on taking two similar petals of *Passiflora*, and making one anode and the other kathode, it was found with a moderate E.M.F. that death-discoloration took place at the kathode, at a temperature of 4° C. lower than at the anode (p. 185), thus proving that under these conditions it was the kathode which produced excitation. I was now desirous of finding out whether the same test could not be applied to the demonstration of the reversed effect due to high E.M.F., and in this connection I shall give an account of an experiment on the coloured petals of *Sesbania coccineum*, the death-discoloration of which occurs normally at 65.5° C. Taking two similar petals, and using the high E.M.F. of 220 volts, I found on sending a current that death-discoloration took place at the anode, at 60° C., that is at 6½° below the normal. The discoloration point of the kathode was also lowered, but only slightly, being 2½° below the normal. We thus see that with a high E.M.F. it is the anode which is more excitable at make. It is clear from this that the reversal of the normal polar effect has set in, the anodic excitation being considerably predominant.

Reversal of polar effects as due to fatigue or tissue-modification.—It has now been demonstrated that an excessively strong E.M.F. is one of the conditions by which the

reversal of normal polar effects may be brought about. We shall next study other circumstances which may also be efficient to induce this reversal. This subject assumes the greater importance from the difference of opinion which exists among investigators in animal physiology as to the possibility of such reversal. The question has not yet, as far as I am aware, been definitely settled. Thus, 'Aeby thought he had proved that under certain conditions, more particularly with progressive fatigue of the preparation, the normal reaction—in which the excitatory action of the kathode far exceeds that of the anode—was exactly reversed. Aeby's experiments, however, are by no means unimpeachable, as both Engelmann and Hering pointed out later. Engelmann, also, came to the conclusion later, that such a complete reversal of phenomena (*i.e.* of the law of polar excitation) might take place. But until it has been determined by unexceptional experiments, there must be great scepticism in regard to such statements.'¹

We now turn our attention to that of the changed condition of the tissue by which the normal polar response may become reversed, and in this regard the experiments which I shall describe are very instructive, as these changes are there seen to occur progressively. I took a specimen of *Mimosa* and carried out on it five consecutive experiments. The two electrodes were attached to the pulvini of different leaves on the same stem, and the E.M.F. used was fifty volts; an interval of about seven minutes was allowed in each case for recovery. For easy inspection, the results are given in somewhat tabular form.

(1) *At make*—Leaves fell both at kathode and anode. The kathodic fall was earlier and more energetic.

At break—No decisive effect observed at either electrode.

(2) *At make*—The kathodic leaf fell, and the anodic fall was slight.

At break—No action at kathode, but energetic fall

¹ Biedermann, *Electro-Physiology*, English translation, 1898, vol. i. p. 271.

at anode. The action of anode-break was here much stronger than that of kathode-make.

(3) *At make*—Fall of kathodic leaf ; no action at anode.

At break—No action at kathode ; response at anode.

(4) *At make*—Kathodic action became feeble, and anode-fall, though at make, the more pronounced of the two.

At break—No action at either electrode.

(5) *At make*—No action at kathode ; feeble action at anode.

At break—No action at either electrode.

In tracing out the changes which are here taking place at each electrode, we are struck by their progressive character. If we fix our attention first on the kathode, we find that the normal effect in the first of the series is gradually diminished, till it disappears in the last. Again taking the anode, we find a still more remarkable change, of a periodic character. In the first experiment, we observe the most pronounced abnormality, or reversal of the series, inasmuch as there was response at make and none at break. In the second, the response is tending towards normal, the anode-make effect being feeble, and the break strong. In the third, the anodic response has become normal, for there is no action at make, but excitation at break. In the fourth, we again see a tendency towards reversal, inasmuch as again there is response at make and none at break. The same state of things, though in a less degree, occurs in the fifth experiment.

We have thus observed two different conditions, each of which may contribute to produce this reversal of polar effects. These are, firstly, the influence of a high E.M.F., which, at or beyond a certain critical value, will produce reversal ; and, secondly, certain tissue-modifications similar to those which we have observed during the progress of fatigue. It is clear that with slight tissue-modification the critical value of the E.M.F. at which, under normal conditions, reversal of polar effects would take place, will be lowered. This, the experiments on *Mimosa* just described clearly show ; for in them we see that reversal has set in at the relatively low E.M.F. of

P

fifty volts, whereas normally in *Mimosa* the critical value is considerably above a hundred volts. These tissue-modifications sometimes proceed so far that I have occasionally observed reversal in the case of this plant even with a moderate E.M.F.

I was next desirous of determining whether these different types of polar effects—normal, transitional, and reversed—could not be demonstrated in some novel and striking manner, in the case of animal tissues. It occurred to me that the intermittent flashes of light emitted by the firefly might be simple expressions of rhythmic excitation, a subject which will be dealt with in detail in Chapter XXIII. The emission of light, or an increased intensity of emission on the part of the insect, would in that case be indicative of the state of excitation, and this mode of excitatory expression I shall designate as glow-response.

Investigation of polar excitation by glow-response.— I may here state in anticipation that I have succeeded in demonstrating, by means of this glow-response, all the principal characteristic effects of (*a*) normal response, due to moderate electromotive force; (*b*) the reversed effect due to high electromotive force; and (*c*) the reversed effect due to a modified condition of the tissue. It may be pointed out further, that some specimens gave the normal, and others, owing to a modified condition of the tissue, the reversed effect; but that the results obtained from any given individual were always consistent and characteristic.

I shall first describe certain results which were frequently observed, and which are entirely analogous to those described in a previous chapter as given by a nerve-and-muscle preparation, and highly excitable tissue of *Mimosa* (p. 197). We there saw that while the current was ascending, the excitation exhibited by the terminal organ at make was due to direct action of the proximal kathode. Excitation was also produced at break, and this was due to the transmission of the distal anode-break effect. Again, when the current was reversed, excitation was exhibited in a corresponding manner,

through the action of the distal kathode make and the proximal anode-break.

The firefly under natural conditions emits flashes of light at intervals of about three seconds, from two discs, situated on the ventral surface of its tail.

We select a specimen and make suitable electrical connections, one with the head, and the other with the luminous disc. The natural luminescence of the insect is moderate and intermittent; but on now passing through it a descending current from a battery having an E.M.F. of twelve volts, the light at once becomes persistent and very brilliant. We must bear in mind that the luminous discs stand here in the place of the terminal motile indicator, of the nerve-and-muscle or *Mimosa* preparation, and that the state of excitation is indicated in them by the increase of luminescence instead of by an excitatory movement. This glow-response, then, is due to the action of the proximal kathode-make. The induced brilliance slowly dies down, and in the course of a minute and a half becomes very feeble. If the circuit be now broken, a single intense flash is produced, due to the excitation of the distal anode-break. The insect now recovers from the state of induced excitation, and begins once more to exhibit its natural intermittent flashes. We next pass the current in the reverse, that is to say ascending, direction. The light again becomes persistent and brilliant, owing to the excitatory action of the distal kathode-make. During the continuation of the current, the light wanes and becomes feeble. But when the circuit is broken, there is once more seen a single flash of intense light, due to the action of the proximal anode-break.

In order to ensure a simpler condition for experiment by eliminating the nervous conduction of excitation, I next isolated the double disc, and found that the detached organ maintained its excitability for a couple of hours or more. The discs now emitted a light which was somewhat feeble but not intermittent. Electrical connections were then made with the two discs, by means of fine cotton threads, moistened with saline solution, and an E.M.F. of sixteen volts was used.

At make the cathodic disc was found to become very brilliant, and there was no effect on the anodic. In some instances, indeed, the anode became dimmer than usual, thus showing the depressing influence of the anode. At other times, again, the luminous excitation of the kathode irradiated and encroached upon the anodic region. At break it was the anode which flashed out, showing excitation. These results, as will be seen, are entirely normal. I shall next describe experiments which illustrate the reversed effect sometimes observed with excessively high E.M.F., and at other times due to a modified condition of the tissue.

With regard to the production of the reversed effect under a high E.M.F., some difficulty is encountered owing to the proximity of the two discs of the luminous organ. The effect of one electrode is thus liable to encroach on the region of the other. But specimens are occasionally obtained in which, the conducting power of the tissue being feeble, each effect is practically confined to its own area, though the excitatory E.M.F. may be high.

In the following investigation it is to be noted that successive experiments were carried out on the same specimen, without disturbing the electrodes. By proper manipulation of the key, the current was made to flow now in one direction, then in another, or the acting E.M.F. was changed from low to high at will. The differences of the results observed must therefore have been due, either in the first case to the reversal of anode and kathode, or in the second case to the difference in intensity of the E.M.F.

A specimen was taken of the detached luminous organ, and electrical connections were made with the two discs, by means of moistened threads. An E.M.F. of ten volts was first used, and the effect at make was a brilliant illumination of the kathode-disc. During the continuation of the current this gradually waned, but at the break of the circuit a brilliant flash appeared at the anode. Thus we have, in the present case, the normal effect with moderate E.M.F. I next used with the same specimen the high E.M.F. of fifty volts.

The luminescence at make now took place at the anode, and at break at the kathode. On reversing the current, the new anode, formerly kathode, gave responsive illumination, and at break the new kathode responded. In these results, therefore, it will be seen that we have an instance of reversal of polar effects, under excessively high E.M.F.

These reversed effects are usually observed with a high E.M.F. ; but sometimes, as has been said, owing to a modified condition of the tissue, they may be obtained, under the action of even a moderate E.M.F. I shall now give a very interesting example in which we can trace the process of reversal owing to the modification induced by fatigue, in a manner somewhat similar to the last experiment described in the case of *Mimosa* (p. 209).

I took a fresh specimen of the detached organ, and carried out four successive experiments on it, observing the effects at both make and break, the E.M.F. used being twenty volts. In order to present these results at a glance, I shall again put them in a somewhat tabular form.

(1) *At make*—Luminous response at kathode, which irradiates slightly towards anode.

At break—Little effect at anode, but natural luminosity of the kathode falls below par. This shows the depressing action of kathode-break.

(2) *At make*—Luminous response at both anode and kathode.

At break—Luminous response at kathode only. These effects, especially that of break-excitation at kathode, show that the condition of reversal has set in. This will become still more pronounced in the succeeding experiments.

(3) *At make*—Luminous response appears at anode and irradiates slowly towards kathode.

(It will be seen that we have here a complete reversal of the effects observed in (1) at make.)

At break—No immediate effect is at first observed ; later, a flash passes from anode to kathode.

(4) *At make*—Luminous response at anode.

At break—No effect at anode, but feeble augmentation of luminosity at kathode.

These results afford us some insight into that obscure phenomenon of the modified condition of tissue by which reversal of response is brought about.

We have seen that in the case of *Biophytum*, the polar effects are always found to be normal, within rather a wide range of E.M.F., that is to say, up to about thirty volts. The kathode here excites at make, and the anode at break. I have carried out several hundreds of experiments with this plant, but have not once come across any deviation from this normal action.

As the E.M.F. was progressively increased, however, we found in this and other plants a tendency towards the reversal of these normal polar effects. During the first, or *A*, stage of this reversal, the excitatory value of the kathode was seen to undergo a diminution, and the anode, which normally had a depressing influence, was observed to have its property reversed, and to produce excitation. The result during this stage, therefore, was the exhibition of excitation at both kathode and anode at make.

With still higher E.M.F. the *B* stage was reached, and here there was a complete reversal of the normal polar effects. It was then found that the anode produced excitation at make, and the kathode at break. This reversal of polar effects under a high E.M.F. was further demonstrated by means of Death-response in plants, and Glow-response in animals.

We have also seen that in consequence of progressive molecular change induced by fatigue, the normal polar effect tended to be reversed, and we have been able to trace the successive stages of such a reversal, in experiments on the plant *Mimosa* and on the firefly.

And, finally, specimens are occasionally found which, owing to molecular modifications of their tissues—modifications that a knowledge of their previous history could

alone enable us to explain—tend to exhibit abnormal polar effects.

SUMMARY

Under high E.M.F. the normal polar excitation tends to be reversed. In the *A* stage, both the anode and kathode excite at make, and either kathode or anode at break; in the *B* stage—that is, with excessively high E.M.F.—it is the anode which excites at make, and the kathode at break.

The firefly under excitation exhibits glow-response. Under moderate E.M.F. it shows normal polar effects. Under a high E.M.F. it, like the plant, exhibits a reversal of these polar effects. Under fatigue, or other tissue-modification, normal polar effects tend to undergo reversal.

CHAPTER XVIII

ON CONDUCTIVITY AND EXCITABILITY

Receptive excitability, conductivity, and motile excitability—Molecular model—Modification of motile excitability : (a) by anæsthetics—(b) by cold—(c) by fatigue—Variation of conductivity : (a) by cold—(b) by rise of temperature—(c) by fatigue—(d) by anæsthetics—Variation of receptive excitability by ether—Conductivity *versus* excitability—Abolition of motile excitability without abolition of conductivity—Hydro-mechanical theory of transmission of stimulus untenable.

HITHERTO we have been concerned mainly with the peculiarities of the responding organ, by which the state of excitation is outwardly manifested. Very often, the responding organ is not directly stimulated, but a distant point is acted on by stimulus, and the state of excitation is transmitted through the intervening distance, by the conducting power of the tissue. In the actual life of a plant it is frequently the case that the stimulus impinging on a receptive area is transmitted along conducting channels, and is manifested, on reaching some responsive organ. The whole cycle of events is something like a telegraphic circuit, in which the message taken at a transmitting station is sent to a distance along conducting wires, and produces a signal at the distant or responding station.

In our experiments, for example, on *Biophytum*, as given in the previous chapter, the stimulus was applied at the petiole, and was conducted along certain channels. On reaching the specialised motile organ—the pulvinus—this transmitted stimulus caused a responsive depression of the leaflet. The petiole, during conduction of stimulus, was excited, but there was no conspicuous external evidence of this, because, first, the contractility of the tissue was relatively feeble, and

second, the differential excitability, on which responsive curvature depends, was also slight. It is only at the pulvinated organ that the state of excitation is conspicuously exhibited by motile response.

In the case of the plant, therefore, we have to study the excitable property of the receptive area, the conducting property of the transmitting tissue, and that property of the responding organ by which the excitatory effect is outwardly manifested. It will be convenient to distinguish the excitability at the point of application of stimulus from that of the motor region, by using a specific term for the former. I shall therefore designate it as *receptive excitability*, or merely as *receptivity*, whereas the excitability of the motor region will be described simply as *excitability*. At the point of application, the stimulus comes from outside, and produces internal changes. In the motile region, the internal excitatory disturbances are manifested outwards. In the physiological study of excitation, some confusion is apt to arise from the failure to discriminate between these three factors. And this confusion becomes greater in those cases in which the area of motile excitability coincides with that of receptivity.

Molecular model.—The state of excitation being ultimately due to molecular upset from the position of equilibrium, we can understand that such a disturbance is propagated from molecule to molecule, till it reaches the responding organ. We may, perhaps, be enabled to visualise this better by means of a mechanical model. The individual molecules in our model should hold a position of stable equilibrium. When disturbed from this stable poise, they should return automatically to the equilibrium position; and further, the derangement of one molecule should cause a subsequent disturbance of the next, and this disturbance should be transmitted from point to point.

These conditions are realised in the case of the following model, which consists of a row of small suspended spheres of cork, within each of which is placed a magnetic needle. Each

sphere is now in stable equilibrium, under the directive action of the earth, and the mutual action of the needles ; hence the north pole of each needle, represented by the arrow-head, points to the north, which is, say, to the left. The disturbance of any individual sphere, say E, brings about the disturbance of its neighbour, and, owing to the mutual magnetic action between contiguous north and south poles, a derangement initiated in this way is transmitted onwards. Such a disturbance may be initiated by means, for instance, of

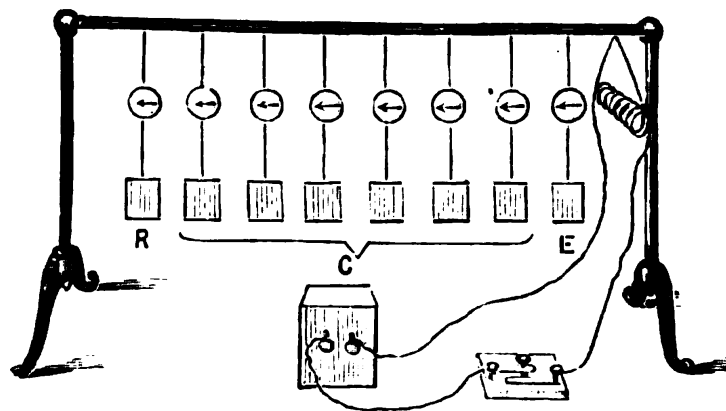

FIG. 95. Molecular Model Exhibiting (a) Excitability at the Receptive Area ; (b) Conductivity of Intervening Region ; and (c) Mechanical Response of Terminal Responder

Disturbance is initiated at the sphere connected with E, by the magnetic action of the electro-magnet seen to the right. This disturbance is conducted by the intervening spheres and reaches the terminal responder, R. Molecular viscosity is increased by immersion of attached dampers in viscous fluid.

a small electro-magnet, placed at right angles to the molecular magnet in E. This electro-magnet is magnetised for a short time by the tapping of a key, which closes an electric current, causing a rotation of the sphere E. The intensity of this disturbing force, the stimulus, may be increased at will, by appropriate exaltation of the strength of the magnetising current (fig. 95).

In such a row of molecules, then, that to the extreme right, E, is the point at which we shall initiate molecular disturbance. That is to say, it corresponds to the receptive

point. The intermediate row, C, is the conductor of disturbance; and the last molecule, R, which may be provided with an index, or a reflecting mirror, by means of which the disturbance can be made conspicuous, represents the motile responder.

We shall next observe how the extent of the distortion of each of the molecules from the position of equilibrium by a given force—that is to say, the amplitude of its response—is modified by the factor of molecular mobility. Under the action of certain agencies the freedom of molecular movement may be retarded, by variation of elasticity or of viscosity. We may, with our model, imitate the resultant molecular sluggishness, by means of dampers, which are seen in the diagram, attached to each sphere. The extent of damping is capable of increase by immersion of the damper in a viscous fluid. The response-curve of this particular sphere may now be taken by the usual method of a reflected spot of light. The curves thus obtained will show, firstly, that, the disturbing force remaining the same, diminished molecular mobility is attended by diminution of amplitude of response; secondly, that this diminution may become so marked that visible response may disappear; thirdly, that though, with a given moderate disturbance, response may thus be in abeyance, yet it may be restored if the disturbing force be made sufficiently strong; and fourthly, that the sluggishness thus induced may also be exhibited by delay in the initiation of response, that is to say, by the prolongation of the latent period.

From such considerations, it is clear that if an agency which reduces molecular mobility be applied on the receptive area, then, inasmuch as the initiation of excitation is prevented, there will be no response exhibited by the motile organ, although the conducting power of the intervening tissue, and the motility of the responding organ, remain unchanged. Again, if the intervening conducting tissue be subjected to loss of molecular mobility by any means, the power of conduction will be either very much retarded, or abolished, the receptivity and excitability of the terminal points

remaining unaffected. And, finally, the excitability of the motor region may be depressed by certain agencies, and the stimulation, initiated at the receptive point, and transmitted through the intervening conducting channels, will nevertheless fail to find expression. We shall next proceed to demonstrate experimentally the influence of various agencies on the receptivity, on the conductivity, and on the excitability of the tissue.

Variation of motile excitability : (a) Under anæsthetics.—

First we shall take the variation of excitability in the motor region. Let us then select a leaf of *Biophytum* and apply ether to the two terminal pairs of leaflets beyond D. Thermal stimulus is then applied at x, by touching with a



FIG. 96. Effect of Ether in the Abolition of Motile Excitability

Ether is applied to the two pairs of leaflets to the right of D; stimulus is applied at x. Excitation travels up to D, and cannot pass beyond.

hot wire (fig. 96). As the receptivity of the point of application, and the conductivity of the intervening tissue, remain unimpaired, the excitatory disturbance proceeds in the normal manner to the point D, a fact seen by the successive

depressions of the leaflets. Owing, however, to the abolition of their excitability, the last two pairs remain unaffected.

A similar loss of excitability, due to the action of ether, may be demonstrated in *Mimosa*. On taking a stem provided with three motile leaves, A, B, and C, the pulvinus of B is touched with ether, and thermal stimulus is applied between A and B. The excitation is transmitted in both directions, up and down, as seen by the fall of the leaves A and C. But the intermediate leaf B fails to respond, showing that its excitability has been abolished by the ether.

(b) *By effect of cold.*—The prolonged application of cold, also, will produce, as would be expected, molecular sluggishness, with consequent loss of motor excitability. This may be shown by touching the small pulvinus of a leaflet of *Biophytum* with ice-water. If stimulus now be

applied on the petiole, it will be found that this particular leaflet will not respond. This loss of excitability will, however, be temporary, disappearing as the leaflet returns to its ordinary temperature, when it will be found to respond as usual.

A moderate application of cold does not altogether abolish the response, but the molecular sluggishness induced is shown in the prolongation of the latent period of response. It was found, for example, in an experiment on *Biophytum* that the latent period was sometimes prolonged by several seconds (p. 268).

(c) *By effect of fatigue.*—We have already seen (p. 113) how the motile excitability of the plant-tissue is diminished by fatigue, as shown in the diminution of successive responses, when the intervening periods of rest are not sufficient for complete recovery. We have seen, too, that under strong and long-continued excitation the motile excitability is abolished; and that it can be restored after the lapse of a sufficiently long resting period.

Variation of conductivity.—We shall next examine how the transmission of stimulus from point to point is affected by various external agencies. And, first, we shall refer back to the mechanical model (fig. 95). We there saw how the sluggishness, induced in the intermediate molecules by plunging the dampers to a greater or less depth in a viscous liquid, retarded the transmission of disturbance through them. When this induced sluggishness is slight, the propagation will merely be slowed below the normal; but when the sluggishness induced is great, the disturbance will not reach the responder R.

(a) *By effect of cold.*—We shall now proceed to investigate the effect of induced molecular sluggishness on the conductivity of a plant-tissue; and for this purpose we shall first observe the influence of cold. In an experiment on *Biophytum*, I found that the normal velocity of transmission, depending on the conductivity, was 3.7 mm. per second; but on subjecting the tissue to moderate cold, the

velocity of transmission was reduced to 1.3 mm. per second, or nearly to one-third of its original value (p. 249); a still greater application of cold produces a temporary abolition of conductivity. This may be shown by touching

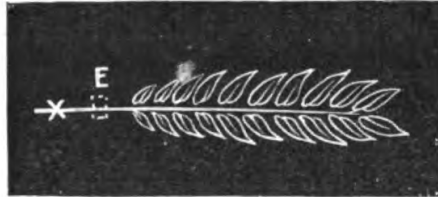

FIG. 97. Experimental Demonstration of Effects of Cold and Anæsthetics in Abolishing Conductivity.

Cold or ether applied at E; stimulus at X cannot be transmitted across E, and there is no effect on the motile leaflets.

a given portion, E, of the petiole with ice, when moderate stimulus applied below such a point will not be transmitted across the lethargic area, and the motile leaflets beyond will remain unaffected. The normal conductivity will, however, be restored when the tissue regains the temperature of the surrounding atmosphere, and a second similar

application of stimulus will then be found to be conducted to the motile leaflets, producing successive depressions (fig. 97).

(b) *By rise of temperature.*—We have seen how, in consequence of the molecular sluggishness induced by cold, the conductivity of the tissue is lowered. A rise of temperature might therefore be expected, by increasing molecular mobility, to enhance the conducting power. That this is the case is shown in detail in Chapter XX. In a leaf of *Biophytum*, for instance, it was found that a velocity of 3.7 mm. per second at 30° C. was increased at 35° C. to 7.4 mm., and at 37° C. to 9.1 mm. per second. Thus, by a rise of temperature of from 30° C. to 37° C. the conductivity of the tissue was increased to nearly three times its initial value.

(c) *By effect of fatigue.*—We have already seen (p. 111) that motile response, and the transmission of excitation, are both alike expressions of the protoplasmic changes induced by stimulus. We there saw also that just as fatigue of motile excitability was exhibited by diminished motile response, so too a diminished speed of transmission exhibits fatigue of conductivity. An experiment will be described

later (p. 245), which shows that in that case, under moderate fatigue, conductivity was diminished by 18 per cent. of its normal value.

The following experiments give us a further and striking demonstration of the diminution or abolition of conductivity under fatigue. If we take a leaf of *Mimosa*, and excite it, by snipping off a terminal leaflet, borne on one of the four sub-petioles, the stimulus, transmitted along the narrow conducting channel of that sub-petiole, and passing through the large channel of the petiole, will, on reaching the pulvinus, cause the fall of the leaf. After a suitable period of rest, the leaf will re-erect itself. If now the operation be several times repeated, by stimulating the same sub-petiole, it will be found eventually that the leaf no longer responds. That this is due to the fatigue in conductivity of the sub-petiole may be proved, by snipping a leaflet off a second sub-petiole, which will be found to conduct the stimulus, and produce depression of the leaf, as did the first sub-petiole when fresh. It will be noticed here that the excitation which abolished the conductivity of the first sub-petiole, did not abolish that of the main petiole. This is due to the fact that the somewhat enfeebled stimulus on reaching the petiole is spread over a larger channel, and therefore the strain-effect which it produces there is relatively much less.

(d) *By effect of anæsthetics.*—We shall now study the effect of anæsthetics on conductivity. This may be shown by the local application of ether to the petiole, in the intermediate portion of a *Biophytum* leaf, beyond, say, the first three pairs of leaflets. Stimulus applied below this area will be conducted to it, as seen by the fall of intervening leaflets, but its further passage will be blocked, and neither the leaflets of the etherised area, nor those beyond, will show response. That this abolition of conductivity, however, is only temporary, is seen when the stimulus is repeated after blowing off the ether vapour. All the leaflets, from first to last, will now be found to respond. If etherisation, however, be carried too far, the abolition of conductivity persists for a long time,

and its restoration may not take place for one or more hours.

An interesting experiment, on the abolition of conductivity under ether, was performed with a specimen of *Biophytum* having eight leaves of fairly equal sensitiveness. Of these, four, taken alternately, had ether applied on those portions of their petioles which were next to the stem. On now applying strong thermal stimulus on the stem, the state

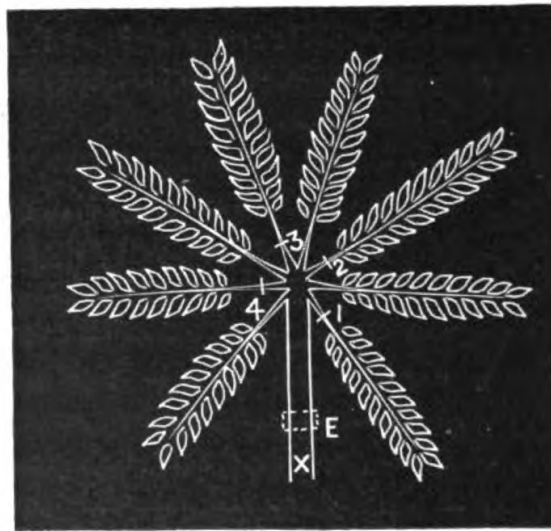

FIG. 98. Diagrammatic Representation of Experiment on *Biophytum*

Ether was applied on the alternate petioles marked 1, 2, 3, 4. Stimulus at \times is prevented from acting on the leaflets of these leaves.

The same diagram also represents the subsequent experiment on variation of receptive excitability. Ether is applied at E instead of on the petioles. Stimulus applied at E now produces no excitation.

of excitation radiated to all the leaves. But the passage of stimulus through the four etherised petioles was blocked, and no effect was produced on their leaflets. The leaflets of the non-etherised leaves, however, promptly responded, falling one after another from the centre outwards (fig. 98).

Variation of receptivity by anæsthetics.—Lastly, we shall inquire into the variation of excitability at the point of application of stimulus, that is to say, into the modification of the plant's receptivity, under the action of an external agent. It is to be borne in mind that stimulus coming from

without directly affects the outer layer of the tissue, and the excitation may then proceed inwards and in lateral directions, by conduction.

The effect of ether in diminishing receptive excitability may be demonstrated by taking, as in the last case, a specimen of *Biophytum*. We first test the specimen by applying a moderate stimulus on the stem at E. The excitation thus initiated at the receptive area is transmitted to the leaves, and causes depression of their leaflets. When these have recovered, ether is applied locally on the area E. On now repeating the stimulation, we find that none of the leaflets respond. Since the conductivity of the intervening tissue and the excitability of the motile organs have remained unaffected, it is clear that the failure to respond is in this case due to the depression of receptive excitability by ether.

A tissue, however, whose superficial excitability is depressed in this way, may still retain the power of conduction. This is shown by applying stimulus on the stem, as in the last experiment, but at \times , below the etherised ring E. The stimulus is now shown to be transmitted, by the fall of the motile leaflets. The explanation of this difference probably lies in the fact that the molecular torpidity induced by the etherisation does not extend very deep, unless it has been excessive and long-continued. In that case, the internal layer of the tissue, remaining unaffected, would serve as the channel of conduction. This view is supported by the fact which I have noticed, that it is much easier to produce a complete block to the passage of stimulation, when a relatively thin tissue, such as the petiole of a leaf, is etherised. It is much more difficult, on the other hand, to do this with a thick stem.

We saw from the molecular model (fig. 94) that though when the molecules were sluggish no response could be obtained to moderate stimulus, yet when the stimulus was very strong response could be brought about. Similarly, in experimenting on plants, I have found it possible, by careful graduation of etherisation, to arrange matters in such a way

Q

that while moderate intensity of stimulus, applied on the etherised area, failed to evoke a responsive movement of the distant leaflet, a powerful stimulus was able to do so.

Receptivity versus motile excitability.—At the beginning of the present chapter, I drew attention to the necessity of discriminating between the functions of receptivity and motile excitability. It is only by carefully distinguishing these that we can possibly come to an understanding of certain apparent contradictions. Let us suppose that stimulus is applied on a motile organ, say the pulvinus of *Mimosa*. In this particular case, the areas of receptivity and motile excitability are coincident. By the reception of stimulus the motile machinery is eventually set in motion. The mobility of the superficial particles will thus determine the receptivity and the inner mechanism of the organ, the motile excitability. The motile excitability is measured by the amplitude of response. Receptivity, on the other hand, may be partially discriminated by (1) the length of the latent period, and (2) the value of the minimally effective stimulus.

When a tissue is cooled, say to 7° C. or lower, its receptivity and motile excitability both undergo diminution. Hence the latent period is prolonged (p. 268), and the stimulus which was formerly effective becomes ineffective. In such a case, where the two factors conspire, it is difficult to distinguish between the relative effects of receptivity and motile excitability. But when, on the other hand, the temperature is raised, say to 35° C., the amplitude of contractile response, by which we are in the habit of gauging the motile excitability, is generally speaking diminished (fig. 79). Hence we are apt to infer that excitability in general is decreased at 35° C.

But if we test this question by means of the minimally effective stimulus, we arrive at a very different conclusion. For example, taking a specimen of *Biophytum* at 30° C., I found that the minimally effective stimulus was given by a condenser charged to twenty-two volts, whereas when the temperature was raised to 35° C. the minimally effective stimulus was a charge of fourteen volts. It is clear from

this that the excitability at 35° C. is higher than at 30° C.¹ Hence we arrive at two conclusions directly opposed to each other.

This apparent anomaly completely disappears, however, in the light of the distinction between the receptive and motile excitabilities; for it was said that it was the mobility of the superficial particles which determined the receptivity, and this is evidently enhanced by rise of temperature. The amplitude of mechanical response, however, by which we measure the motile excitability, is not solely dependent on molecular mobility. This mechanical response is, as we have seen, brought about by diminution of turgor, and any agent which produced increase of turgor would act antagonistically, and thus diminish the motile expression of excitation. For example, we have seen that a pulvinus of *Mimosa*, when highly turgid, failed to show any motile response, though excited (p. 49). Now, it will be shown (p. 400), that rise of temperature has the effect of increasing turgor. Hence the diminution of mechanical response with increasing temperature does not indicate diminution of excitability in general, but rather the setting in of an antagonistic force, whose influence will be to increase the force of recovery from molecular distortion. It should be mentioned, however, that there is a limit to the enhancement of excitability by rise of temperature; for the molecular disturbance caused by heat will when excessive be detrimental to response.

Excitability versus conductivity.—The same considerations which have thus enabled us to distinguish between receptivity and motile excitability, will also enable us to see the difference between motile excitability and conductivity. We have seen, for example, that at 35° C. the conductivity in a given specimen of *Biophytum* was almost three times as great as at 30° C. in spite of the fact that, as just explained, contractile response is considerably diminished at high

¹ It will be found in Chapter XXX. that growth, which is a phenomenon of excitatory response, is, in the case of many plants, at its maximum at or near 35° C.

temperatures. This distinction between the effects of conductivity and of excitability is especially important, since by its means we are enabled to explain certain facts apparently anomalous, which seem at first sight to lend support to the hydro-mechanical theory of excitation. I have shown that, under normal conditions, the intensity of excitation must exceed a certain value before it can be manifested as mechanical response. I have also shown that under unfavourable circumstances, motile excitability is abolished earlier than conductivity. An excited tissue may thus conduct stimulus, without itself exhibiting any motile indication. Numerous examples of such a state of things may be cited. It must be borne in mind that the mechanical indication of the state of excitation can be afforded by a pulvinate organ, only when there is some difference of excitability as between its upper and lower halves. If this difference of excitability be in any manner reduced or diminished, there will be a failure of the mechanical response. In old leaves of *Biophytum*, for example, not only is the general excitability diminished, but the differential excitability also has disappeared. Hence, excitation of such leaves gives rise to no local excitatory response of the leaflets. But that the leaf is still nevertheless excitable, and can transmit that state of excitation, is shown by the fact that on stimulating it strongly, the leaflets of younger leaves at a distance are, after a time, seen to be depressed in serial succession. This proves that, though unable itself to give the motile indication, the leaf was capable of receiving and transmitting the state of excitation. Similarly, it may be shown that a tissue whose motile excitability is temporarily abolished, by, say, the application of ether, may, nevertheless, be the conductor of stimulation.

In order to demonstrate this, let us take a plant of *Biophytum*, and expose some of the leaflets of a particular leaf to ether-vapour. Strong stimulation of that portion of the petiole which bears them, will now fail to induce movement of the leaflet in the etherised region ; but the excitation

is found to be conducted through the anæsthetised area, and to produce responsive depression, not only of the leaflets beyond, but also of those of other leaves.

This experiment is important in its relation to the theory of the mode of transmission of excitation. I have already adduced conclusive proofs that the conduction of stimulus is dependent, not on the mere mechanical transmission of hydrostatic disturbance, but on the propagation of protoplasmic changes. Strong support has been lent to the hydro-mechanical theory by a classical experiment in which the pulvinus of a leaf of *Mimosa* was chloroformed. On then strongly exciting the leaflets of this leaf, the excitation was found to be conducted across the anæsthetised pulvinus and to produce depression of leaves beyond. At first sight it was natural to suppose that, as the motile excitability of the pulvinus was abolished by chloroform, the conductivity must also have been abolished. It was therefore inferred that, unlike the conduction of stimulus in animal tissues, where such transmission takes place by the propagation of protoplasmic changes, the conduction of excitation in the plant was purely mechanical. It will be seen, however, that the assumption on which this conclusion is based—that conduction must necessarily be abolished, with the abolition of motor excitability—has been invalidated by the experiments which I have just described.

In the present chapter, then, it has been shown that those agencies which, like cold, anæsthetics, and fatigue, diminish molecular mobility, also diminish the excitability and conductivity of the plant-tissue. I shall in the next chapter describe a series of experiments on the profound excitatory changes, of opposite character, which are induced in the experimental tissue, by the passage of an electrical current, the nature of such changes being dependent on the question whether the current enters or leaves the tissue at a given point. It must be added that this series of observations will be found to offer a further disproof of the hydro-mechanical theory of conduction of stimulus.

SUMMARY

Motile excitability is temporarily abolished by anæsthetics.

Strong application of cold produces a temporary abolition of motile excitability. Moderate application of cold prolongs the latent period.

Similarly, fatigue produces a diminution or abolition of motile excitability; and this is restored, after a sufficient period of rest.

Conductivity, similarly, undergoes diminution as the effect of cold, anæsthetics, and fatigue.

Receptive excitability, again, undergoes diminution or abolition by the action of similar agencies.

Conductivity may persist even after the abolition of motile excitability. Hence a strong stimulus may be conducted through a region which exhibits [no motile excitability.

CHAPTER XIX

ON ELECTROTONUS

The anode acts as a block to the transmission of stimulus—Opposite effect of kathode—Experiments on *Biophytum*, showing variations of conductivity by anode and kathode respectively—Experiments on *Mimosa*, showing increase of motile excitability at or near the kathode, and diminution of motile excitability at or near the anode—Curious ‘development’ of response, near the kathode.

WE have seen in the last chapter that on account of the diminished molecular mobility caused by physical and chemical agents, the response underwent a diminution. It was also seen that this reduction of molecular mobility found expression in the diminution of conductivity and excitability. External agents, like cold and ether, produce a temporary reduction of mobility, after which there is a revival to the original condition on the removal of the depressing agents. But certain other agents, such as poisons, produce permanent immobility, from which there is no recovery of response. The tissue is then said to be ‘killed.’

Returning now to the molecular model, described in the last chapter, we see that while stimulus causes molecular upset, yet, at the same time, the force which restores the molecule to its equilibrium position, or, in other words, that which determines its stability, resists such an upset. Let us then first imagine the molecular model to be under the moderate directive action of the earth’s magnetism. The stability of the individual molecule will thus be neither too great nor too small, and we shall call this, for convenience, the normal stability. This stability may further be increased by increasing the external directive force with the help of an auxiliary magnet, arranged in a suitable manner. Or it may

be decreased, below the normal, by the action of an external magnet which reduces the earth's directive force.

On now obtaining responses to a uniform disturbing force, under these three conditions of normal, increased, and diminished stability, we shall find that while in the first case we get moderate response, in the second the response is very much diminished (and may even disappear entirely, when the stability is very great), and in the third it becomes exalted.

An-electrotonus and kat-electrotonus.—I shall now proceed to show the opposite effects of the anode and kathode on molecular responsiveness, during the passage of an electrical current through a plant-tissue. This change, induced by an electrical current, is known as electrotonus, and the effect due to the kathode is distinguished as kat-electrotonus, while that due to the anode is known as an-electrotonus. It is probable that here, also, the variation of sensibility is brought about by the variation of molecular mobility, and that this is induced by an increase or diminution in the conditions of stability, as in the model. These opposite variations of the susceptibility to excitation, due to the anode and kathode respectively, will be demonstrated by the changes which they induce in the conductivity and excitability of the tissue.

In the chapter on the Excitatory Polar Effects of Currents, the intensity of the E.M.F. used was such that the excitation caused by the kathode was visibly manifested in the motile effects to which it gave rise. In the present chapter, however, we shall have to deal with latent excitatory effects, the E.M.F. used not being sufficient to give rise to any immediate external reaction. In the cases referred to, again, the distinctive action of the anode could not be demonstrated inasmuch as under ordinary conditions it could not give rise to any motile indication. It will now, however, be shown that the effect of the anode is one of depression, or the opposite of that of the kathode. In studying variations of conductivity we have to remember that when the conductivity of a tissue is great, the state of excitation is transmitted

either with greater velocity or to a greater distance ; but if conductivity be in any way diminished, the distance to which the excitatory disturbance will be transmitted, will be correspondingly reduced.

The anodic block.—In order to demonstrate the depressing action of the anode, I took a leaf of *Biophytum*, and sent a current through portions of it, entering at A, the anode, and leaving at K, or kathode (fig. 99). The E.M.F. used was two volts, and was thus insufficient to cause responsive action.

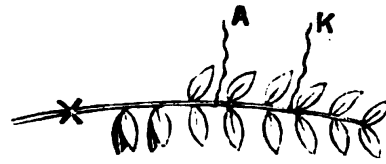

FIG. 99. Effect of Anode as Block.
A, Anode ; K, Kathode

The progressive wave of excitation, initiated at x, stopped by anode, one pair of leaflets to its left.

In this and the following experiments, it will be understood, unless the contrary is stated, that the intensity of the electrotonic currents was not such as to create any direct action at the kathode. Thermal stimulus was now applied at x, and the excitatory wave was found to be stopped at a distance of one pair of leaflets to the left of A. This shows that the depressing effect of the anode acts as a block to the passage of stimulus, and that such depressing action extends to some distance beyond the anode itself.

Experiments showing differences of anode and kathode.—In order to show that the kathode acts differently from the anode, not offering a block, but rather facilitating the passage of stimulation, I performed another experiment on a leaf similar to the last. In that case, the anode was near the point of application of stimulus. I now made the nearer electrode kathode.

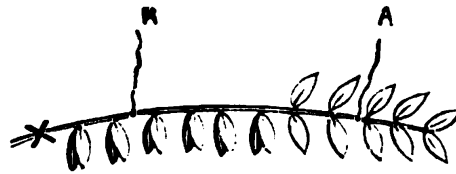

FIG. 100. Experiment showing the Transmission of Excitatory Wave through Kathodic Area, and its Stoppage by the Anode

Stimulus was applied at x.

On next applying the usual stimulus, the excitatory wave passed on through the kathodic area, producing successive

fall of leaflets, and was only stopped by the depressing action of the anode, which this time extended to a distance of two pairs of leaflets to the left of A (fig. 100).

The next experiment was devised to show the opposite effects of anode and kathode simultaneously. For this, the

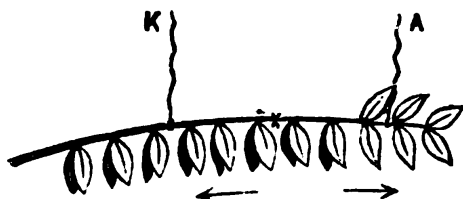

FIG. 101. Demonstration of Simultaneous Opposite Effects of Anode and Kathode on Transmission of Excitation

Stimulus applied in interpolar region at x. Excitation is transmitted through great distances in the kathodic region, but limited in the anodic.

stimulus was applied in the interpolar region, half-way between the two. Two wave-systems were found to start from the excited point in opposite directions. That towards K not only reached K, but passed beyond it, causing the depression of all the leaflets, six pairs in number,

on that side. But the excitatory wave that travelled towards A passed through only two pairs of leaflets, and was stopped at a point one pair to the left of the anode (fig. 101).

Electrotonic variation of motile excitability.—We have seen that protoplasmic excitability finds expression in, among other things, the conductivity and motile response of the tissue. We have seen also how the former, that is to say, the conductivity, is modified in opposite ways by the influence of the anode and kathode. I shall now proceed to describe experiments in which the opposite character of the effects at anode and kathode is still more strikingly demonstrated by the exaltation at kathode, and depression at anode, of the motile excitability.

I used two pairs of electrodes, the first pair, KA, for the purpose of producing stimulation; and the second pair, K'A', in order to produce variation of excitability, through electrotonus (fig. 102); or *vice versa*. The first pair was applied on the stem, the kathode K being in contact with the pulvinus of the lateral leaf. K'A' were applied on the petiole of that leaf.

The plant was very sensitive, and in order that there should be no responsive fall, by the direct and unaided

excitatory action of K, the current due to an E.M.F. of two volts was reduced, by separating A from K, and thus interposing a greater resistance. A distance was thus found—*i.e.* 10 cm.—such that, on completing the AK circuit, the excitation was not sufficient to produce response of the leaf.

The AK circuit was now opened, and adjustments made with the second circuit A'K', with an E.M.F. of two volts, in such a way that, on completing that circuit alone, there was no response of the leaf. Owing to the shorter length of petiole available—*i.e.* 3 cm.—the current could not be reduced to the requisite amount by simply increasing the interpolar distance. An external resistance had therefore to be added, in order to attain the desired condition. Thus either circuit, acting alone, was ineffective.

Kat-electrotonic increase of excitability.—Now, in order to show the increase of excitability in the pulvinus at K, as induced by the neighbourhood of kathode K', we first complete the A'K' circuit. This, as has been said, is ineffective. But now, on making the AK circuit, its previously ineffective stimulus becomes effective, and the leaf responds. From this it will be seen that during the passage of a current through the A'K' circuit, a point in the neighbourhood of the kathode K', that is to say, the pulvinus, is rendered more excitable.

This experiment may be varied by first making the AK, which is now the electrotonic, circuit, and then completing A'K'

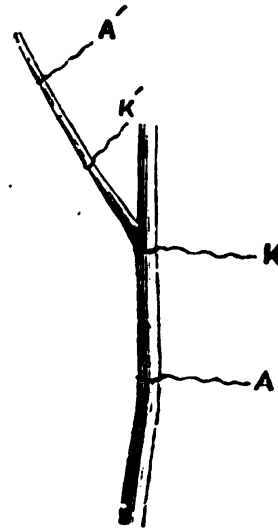

FIG. 102. Diagrammatic Representation of Electrical Connections in *Mimosa* to Exhibit Variation of Motile Excitability, induced by Anode and Kathode

In the first of these experiments, the A'K' circuit is electrotonic and the AK circuit excitatory. In the second and third experiments the AK circuit is made electrotonic, and A'K' excitatory. In the third experiment, A and K are reversed.

for the purpose of stimulation. It is then found that the hitherto ineffective stimulus of A'K' is thus rendered effective.

An-electrotonic depression of excitability.—The depressing action of the anode has been already demonstrated in the case of *Biophytum* (p. 234). The following experiment exhibits the same effect in a different manner in the case of *Mimosa*. In this instance, I used an E.M.F. of four volts in each of the two circuits AK and A'K'. When each circuit was made separately, the leaf responded by depression. At make, then, of one of the circuits the leaf responds, but as the stimulus is only effective at make, the leaf recovers during the continuation of the current. After this, on the second circuit being completed, the excitement at make again caused response.

The experiment was now modified in the following way. The AK circuit was reversed, the pulvinus becoming anode. The excitation of the distant kathode, however, was still strong enough to cause response of the leaf. The current was kept on till the leaf recovered. On now making the A'K' circuit, the leaf did not respond. Thus the stimulus of A'K' at make, which was formerly effective, now became ineffective, by the depressing action of A.

Developing action of kathode.—Another experiment, showing the latent excitatory action of the kathode, is very

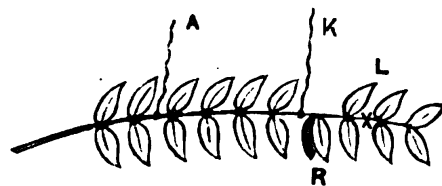

FIG. 103. 'Developing' Action of Kathode

A subminimal stimulus applied at x, ineffective to produce excitation of nearer leaflets, becomes effective in the neighbourhood of kathode.

striking. This experiment, however, is somewhat difficult, as it requires a very delicate adjustment of the stimulus. The specimen used was a leaf of *Biophytum*. A current insufficient to produce any direct excitation was kept flowing through the circuit AK (fig. 101). The

point of special difficulty was to apply a stimulus of exactly subminimal intensity at x, so as not to excite the adjacent leaflet. I have sometimes succeeded in obtaining this condition.

The effect of this imperceptible stimulus, then, which passed through the nearer pair of leaflets, without giving any sign of its presence, became suddenly 'developed' on reaching the further pair of leaflets, R (fig. 103), which were rendered more excitable by the neighbourhood of the kathode.

These peculiar variations, of excitability, induced by the action of the anode and kathode, as well as those caused by other physical and chemical agencies, are exactly similar to what are observed in animal tissues under the same influences. They bring out, further, the essential unity of physiological response, as seen in the highly differentiated protoplasm of the animal and the undifferentiated protoplasm of plant tissue.

SUMMARY

The anode acts as a block to the transmission of stimulus.

The effect of the kathode is opposite to that of the anode.

Motile excitability is diminished at or near the anode, so that previously effective stimulus becomes ineffective.

Motile excitability is exalted at or near the kathode. Stimulus previously ineffective here becomes effective.

CHAPTER XX

ON THE VELOCITY OF TRANSMISSION OF EXCITATORY WAVES IN PLANTS

Difficulties in accurate determination of velocity of transmission, due to unknown variations of excitability arising from injury, and variations of conductivity through fatigue—A perfect method of obtaining accurate and consistent results—Relative advantages of studying conduction in plants as compared with animals—Determinations of velocity of transmission in centripetal and centrifugal directions—Preferential conductivity in centrifugal direction—Diminution of conductivity and excitability by fatigue—Within a certain critical interval, organ 'refractory' to further stimulus—Increased velocity of transmission with increasing stimulus—Measurement of diminution of conductivity by cold—Fibrovascular elements the best conducting channels—Conductivity lengthwise greater than crosswise—Electric mode of determination of velocity of transmission—Indifferent parenchymatous tissues do not transmit stimulation—Comparative tables showing velocity of transmission in various plant and animal tissues.

IN the last two chapters the effects of various agencies on the power of conduction were demonstrated qualitatively. It is important, however, to obtain, if possible, the quantitative values of this conductivity and its variations. The absolute value of conduction can be obtained from the determination of the velocity of transmission of excitation through the tissue. This determination of velocity may be made roughly, by observing the time taken for the application of a stimulus, say by cut or hot wire contact at a given point, to produce motile effects on a leaflet at a known distance.

A result thus obtained, however, would, for reasons to be given presently, prove very indefinite, and no two such results in succession could be trusted to agree. In order to ascertain the exact quantitative effects of various agencies on conductivity, we must first be completely assured that our determinations of velocity under normal conditions are trustworthy.

Difficulties in exact determination of velocity of transmission of excitation.—In the course of the investigation carried out on this subject, I have found that the discrepancies between the velocities, determined in the way described, are largely to be accounted for, first, by indefinite changes of excitability at the point of application, due to the injury caused by excessive stimulation ; and, second, to the changes of conductivity, caused by fatigue, in the rest of the tissue. I have also found that the velocity of transmission is only a determinate quantity when the intensity of stimulus is constant. It undergoes variation, with changes in the stimulation-intensity.

These difficulties are met by using a stimulus which does not cause injury, and which can be repeated at uniform intensity. Such a stimulus is given by means of the condenser discharge. As regards the changes of conductivity due to fatigue, I have found that fatigue is removed, and conductivity fully restored, after a definite period of rest, which, in the case of *Biophytum*, is about four to five minutes.

The next difficulty to be overcome is concerned with the question of recording the exact moment of application of stimulus, and that of the initiation of response at a distant leaflet. A further source of uncertainty in the last respect, lies in the existence of an unknown latent period of the leaflet, which may delay the visible response, even after the effect of stimulus has reached the point at the base of the leaflet.

It is evident that the times of application of such rude modes of stimulation as cut, or contact of hot wire, cannot be accurately determined, and the exact moment of the *beginning* of the responsive movement of the motile leaflet is equally difficult to ascertain by the unaided eye. These difficulties are, however, removed, if we use the discharge from a condenser as our mode of stimulation, and the magnified movement of the spot of light from the Optic Lever, as the indicator of the commencement of response. The observer, following the spot of light from the Optic Lever, makes two

marks on the revolving drum—one when the discharge-key is pressed, at the moment of application of stimulus, and another when the spot begins to move, that is to say, at the commencement of response. It is then easy, knowing the rate of movement of the drum and the distance between the two marks, to determine the exact time-interval between the two.

There then remains only the question of allowing for the loss of time due to the latent period of the responding organ. This is accomplished by means of a separate experiment, in which the stimulus is directly applied at the base of the motile organ. The latent period thus ascertained is subtracted from the time-interval already determined, and we have thus the true time of transmission of excitation through the given distance ; from this the velocity, or rate of transmission per second, may be deduced.

Exact determination of velocity.—I now give an account of an actual experiment for the determination of the velocity of transmission of excitation in the petiole of *Biophytum*. The two points A and B are connected in the circuit of a condenser through the usual non-polarisable electrodes (fig. 14). An indicating leaflet, L, is attached to the Optic Lever, by which the exact moment of its response may be recorded on the revolving drum. If now we make B kathode, during the charge of condenser, an excitatory wave will start from B and travel inwards towards L, in this particular case in a centripetal direction, *i.e.* towards the main stem. A mark is made, as already explained, on the revolving drum, at the exact moment when the tapping-key excites the plant. In this case, the capacity of the condenser was 01 microfarad, and E.M.F. twelve volts. The time of the stimulus reaching L, as indicated by the movement of the spot of light, is also marked, as explained, on the revolving drum. As has been said before, the time-interval is accurately determined from the speed of the revolving drum. As an additional precaution, the same time-interval is taken by means of a stop-watch.

From a separate experiment, by direct stimulation of the base of the petiolule, it was found that the latent period of the leaflet was so small a fraction of a second, as, for our present purpose, to be negligible. In this way, in my first experiment, I found the time taken by the excitation to travel the distance of 27 mm. between B and L to be 14·3 seconds. I allowed the plant a period of rest of three minutes, and again performed the experiment under similar conditions. The time taken was found to be 14·5 seconds, which is practically the same, within experimental error, as the result first obtained. The slight difference was due to the residual effect of fatigue. In any case, the extreme difference between the two results amounts to less than 1·4 per cent.—or 7 per cent. from the mean value of 14·4. From this we find that in the particular plant under experiment the velocity of transmission in a centripetal direction was 1·88 mm. per second. In order to show how consistent successive results are, I give successive time-intervals taken by stimulus in two different cases, to travel the intervening distances.

Case 1.		Time-interval in first experiment	12·6	seconds.
	„	second	„	12·9 „
Case 2.	„	first	„	14·8 „
	„	second	„	15 „

In all these cases, the second experiment was undertaken after an interval of rest of three minutes. The slight retardation uniformly observed is due, as already explained, to residual fatigue. It is, however, so small as to be negligible. At any rate, making allowance for all possible sources of uncertainty, the variation of these determinations will be less than 2 per cent.

We have to remember that, owing to the slow velocity of transmission of impulses in plants, and also to the comparatively great length of tissue, that can, when necessary, be brought under examination, the total interval of time that has to be observed may be made as large as twenty to forty seconds. In such periods, a mean error of even 2 second

R

would hardly produce an inaccuracy of 1 per cent. in the result. This would compare favourably with the determinations that have been made of the velocity of transmission of nervous impulses in animals. In a frog's nerve, for example, owing to the high velocity and comparatively short length of nerve available for experiment, the total interval of time which has to be observed is of the order of some thousandths of a second. To obtain an accuracy within 1 per cent here, would mean the recording and measuring of an interval of something like the $\frac{1}{20000}$ part of a second.

The velocity of transmission in a given plant is found, under normal conditions, to be constant. It varies in different species, and even in the same species the value changes with the season of the year and the physiological condition of the specimen. A velocity determined in winter under less favourable physiological conditions, is very much lower than the velocity of transmission in the same plant in summer.

The exact determination of the velocity of nervous impulses in animals has, therefore, been a matter of some uncertainty. For example,

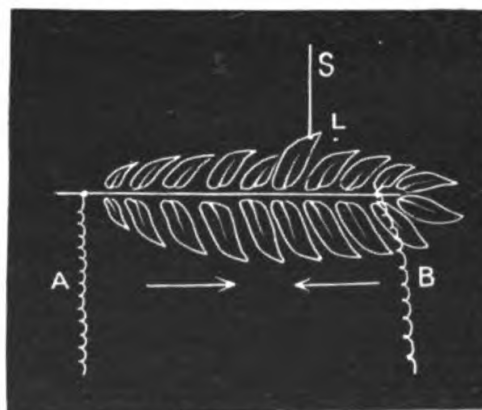

FIG. 104. Diagrammatic Representation of Electrical Connections for Determination of Velocities of Centrifugal and Centripetal Transmissions

A and B are the electrodes, and L the indicating leaflet.

Helmholtz found this velocity in man to be about thirty-three metres per second. Some recent determinations, again, give a value twice as great. Owing, moreover, to the difficulty in exactly discriminating the rising part of the curve, the same record may be interpreted to give results which differ from each other by as much as 20 per cent.¹

Preferential conductivity.—I shall next pass to the consideration of the very curious and interesting pheno-

¹ *Nature*, 1903, pp. 105, 151.

menon of preferential conductivity, by which it is seen that the state of excitation travels through a tissue with greater facility in one direction than in the opposite. For the purpose of this demonstration, I took a fresh leaf of *Biophytum*. The two condenser connections (capacity .01 microfarad charged to twelve volts) were made at A and B (fig. 104). The indicating leaflet L was situated somewhere between. On charge, B became the kathode, and an excitatory wave was started in a centripetal direction. On the abatement of this wave, the condenser was discharged; A now became the kathode, and an excitatory wave was transmitted in a centrifugal direction. From these two successive experiments, we are now able to determine the two velocities in opposite directions in the same leaf.

The following table exhibits the results obtained in this manner with two different specimens :

SPECIMEN I

Direction	Distance	Time	Velocity
Centripetal (B)	22.5 mm.	11.2 seconds.	2 mm. per second.
Centrifugal (AL).	45 mm.	15.2 „	2.9 mm. „

SPECIMEN II

Direction	Distance	Time	Velocity
Centripetal (BL).	28 mm.	15.2 seconds.	1.84 mm. per second.
Centrifugal (AL).	39.5 mm.	17.5 „	2.2 mm. „

Excitatory discharge preferentially directed.—These two observations show that the velocity is greater in the centrifugal direction. In some instances I have found the centrifugal velocity to be nearly twice as great as the centripetal. These experiments seem to indicate that under certain conditions, excitatory discharges will take place preferentially in one direction only. We may imagine any intermediate point in the midrib of the leaf, to be acted on locally by a gradually increasing or accumulating stimulus from

R 2

external sources. Immediately on this reaching the threshold of response, it will give rise to an excitatory discharge. And it is clear that this excitation will be transmitted preferentially along the line of least resistance, that is to say, in the direction of the greatest conductivity, or outwards. I have been able to obtain further experimental verification of this conclusion, by applying a gradually increasing stimulus of condenser discharge to an intermediate point on a petiole of *Biophytum*. When this stimulus had reached a certain value, it was found that while excitation, as indicated by the fall of the leaflets, travelled through a great distance forwards, or outwards, its transmission backwards was extremely limited. Could we have adjusted the stimulus, so as to have been slightly above the threshold of response, there would have been no transmission backwards. When stimulus, on the other hand, is excessive, the entire excitatory effect cannot be carried forward; there is an overflow backwards; and under these conditions excitatory movements take place in both directions.

Effect of fatigue on velocity of transmission. — We shall next deal with the modification of the velocity of transmission by fatigue. Specimens of *Biophytum* were used for the purposes of this investigation, and experiments were performed by ascertaining the times taken for the transmission of a repeated uniform stimulus, through the same distance, under shortening periods of rest.

A stimulus was given to a leaf of *Biophytum*, and the record of time taken—the transmission being in a centripetal direction. The plant was now given an interval of rest of three minutes. Stimulus was again applied, and the time-records obtained in the usual manner. The next stimulus was applied after a resting-interval of two minutes, the following after one, and the last after half a minute, the time of transmission and the records of response being taken throughout. From the results given below, it will be seen how regular is the decrease in velocity with the increase of fatigue. The distance to be traversed, 27 mm., was kept the same in all cases. The time taken at the beginning, when the plant was

fresh, to traverse this distance was 14.3 seconds. In the next experiment, when the stimulus was applied after three minutes, there was a slight residual fatigue, and this prolonged the time to 14.5 seconds. On the third occasion, a still shorter time, namely two minutes, was allowed for rest, and the rate of transmission became slower, the time being now 15.7 seconds. The next interval of rest was still further shortened, to one minute, and the time of transmission was correspondingly increased to 16.4 seconds. And lastly, when the stimulus was given after an interval of only half a minute, the velocity was still further retarded, the time now taken being 17.5 seconds.

The following table gives the different velocities under increasing fatigue, and the heights of the corresponding responses. It has already been said that the distance through which the stimulus was transmitted was in all cases the same, namely 27 mm.

TABLE SHOWING VARIATIONS OF VELOCITY OF TRANSMISSION AND OF AMPLITUDE OF RESPONSE IN BIOPHYTUM, WITH INCREASING FATIGUE

Intervals of rest	Time	Height of response	Velocity
The plant fresh	14.3 seconds	34 dns.	1.88 mm. per second
3 minutes	14.5 "	20 "	1.86 " "
2 minutes	15.7 "	14.5 "	1.72 " "
1 minute	16.4 "	2.5 "	1.64 " "
$\frac{1}{2}$ minute	17.5 "	1.0 "	1.54 " "

It will be seen from this table that, while the variation of velocity due to the difference of conductivity between three minutes' rest and an indefinitely longer period is slight, there is a considerable diminution of this velocity when the resting-periods are still further shortened. It will be noted, moreover, that increasing fatigue is shown not only by a regular decrement in the speed of transmission, but also in an independent and still more striking manner by a steady diminution in the heights of the responses themselves.

The following curve (fig. 105) shows the variation of

motile excitability under shortened periods of rest. This curve when produced will cut the abscissa. Such a point would mark the time-interval between two successive stimuli,

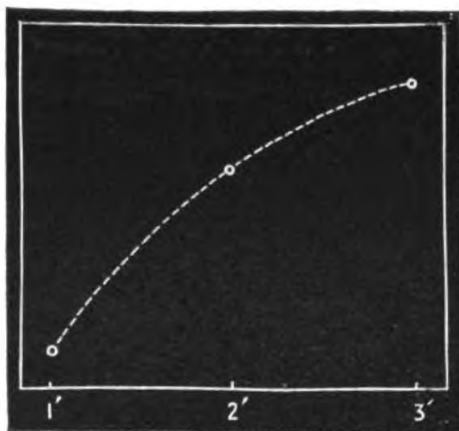

FIG. 105. Curve showing Decline in Heights of Responses, with Diminishing Periods of Rest

Abscissa represents resting-periods, and ordinate heights of response

at which the response would be zero, that is to say, the motile excitability would be abolished. In other words, the leaf would, when the resting-interval was shortened to this period, prove refractory to stimulus. In Chapter XXII the existence of this theoretical refractory period will be demonstrated by experiment.

It is thus seen that owing to imperfect protoplasmic recovery, or, in other words, to residual molecular strain, not only is the conductivity of the tissue gradually diminished, but the excitability also. Thus we obtain some idea of the processes by which fatigue is brought about.

Effect of intensity of stimulus on velocity.—We have next to study the variation in the velocity of transmission of the excitatory condition, with increasing strength of stimulus. In the case of animal nerve, it has been ascertained by different observers (Helmholtz, Vintschgau, and Fick) that the velocity of transmission of the nervous impulse is not independent of the strength of stimulus, but increases with increasing intensity. The experimental verification of this with conducting animal tissue is, however, extremely difficult, owing principally to the shortness of time involved.

I have carried out an investigation on this subject with vegetable tissues, which shows in an unmistakable manner that velocity does undergo an increase, with increasing stimulus. These experiments were carried out with leaves of *Biophytum*. I first demonstrated this in a qualitative manner,

by using thermal stimulation. It was thus found that the excitation caused by a strong, would travel with a greater velocity than that due to feeble stimulus, the one being sometimes double the other. I next tried to obtain quantitative results, by using a form of stimulus which was measurable, and could be increased in a graduated manner. For this I employed the method of stimulation by condenser discharge, the stimulus being increased by increasing the E.M.F. that charged the condenser (·01 microfarad).

In one series, with a stimulus of eight-volt charge, the velocity found was 1·8 mm. per second. When the stimulus was increased by charging the condenser to twelve volts, there was an increase of velocity to 1·9 mm. per second. And finally, with a sixteen-volt charge, the velocity was found to be 2·1 mm. per second. These velocities referred to centripetal transmission. In the next series, the experiments were carried out on a much more excitable leaf, and the velocity was determined in a centrifugal direction; with a charge of eight volts, the velocity was 3·27 mm. per second; with sixteen volts, it rose to 3·76 mm.; and with thirty-two volts, it became 3·83 mm. per second. The two following tables exhibit these results of increasing velocity with increasing stimulus:

TABLES SHOWING INCREASE OF VELOCITY WITH INCREASING STIMULUS

*Specimen I.—Centripetal transmission.**The distance traversed by stimulus was 27 mm.*

Stimulus	Time	Velocity
·01 microfarad charged to 8 volts	14·9 seconds	1·8 mm. per second
" " 12 "	14·4 "	1·9 mm. "
" " 16 "	12·8 "	2·1 mm. "

*Specimen II.—Centrifugal transmission.**Distance traversed by stimulus was 38 mm.*

Stimulus	Time	Velocity
·01 microfarad charged to 8 volts	11·6 seconds	3·27 mm. per second
" " 16 "	10·2 "	3·72 mm. "
" " 24 "	10·1 "	3·76 mm. "
" " 32 "	9·9 "	3·83 mm. "

The stimulus, it is to be remembered, is increased by increasing the voltage. But, on an undue increase of this charging voltage, to about forty volts or upwards, I have often found that the velocity undergoes an actual diminution. This is to be ascribed to the fact, which was demonstrated in the chapter on Polar Effects of Currents, that the excitatory value of the kathode reaches a limit, with a certain E.M.F., and that if the E.M.F. be carried far beyond this, the excitatory effect is reversed, that is to say, it is now the anode that excites (p. 206). We have then the curious case of a negative direction, as it were, of transmission. For whereas, with moderate voltage, the excitatory disturbance travels in the interpolar region from kathode to anode, it now, with excessive voltage, travels in the opposite direction, from the anode towards the kathode.

We can now see with what great accuracy it is possible to measure these changes of velocity, from which we can deduce the variations of conductivity, not merely qualitatively, but also quantitatively. This opens out to us the further possibility of studying the quantitative effects of various external agencies in modifying conductivity. I shall here relate a simple experiment which affords an example of the method to be followed in such an investigation.

Effect of lowering of temperature on velocity of transmission.—In order to study the effect of lowered temperature on conductivity, I applied ice-cold water over an area of 10 mm. of the conducting petiole in *Biophytum*. The length of the conducting tissue experimented upon was 38 mm., and the time taken for the stimulus of a condenser-discharge (ten volts and 0.1 microfarad) under normal conditions, *i.e.* before the application of ice-cold water, to traverse this length, was 10.1 seconds, giving a velocity of 3.76 mm. per second. But after the application of ice-cold water, the conductivity was so diminished that the stimulus did not produce any response. The stimulus was then applied allowing the temperature of the petiole to rise with leaves of to rise a few degrees, the stimulus was again applied and

but the velocity of transmission was now found to be much reduced. Instead of 10·1 seconds being necessary for transmission through the entire length, it was now found to take 14·8 seconds. The difference of 4·7 seconds here, represents the additional time taken for transmission through the 10 mm. length of cooled tissue. In other words, whereas transmission through 10 mm. of normal tissue had taken about 2·6 seconds, it now took about $2·6 + 4·7$, or 7·3 seconds; that is to say, the conductivity was reduced by cooling to nearly one-third.

Effect of rise of temperature on velocity.—It has been proved that conductivity is reduced by lowering of temperature. We should therefore expect that a rise of temperature would produce the opposite, namely, an increase of conductivity. That this is the case was shown by an experiment on a leaf of *Biophytum*. Care was taken that the leaf should not be too young, since, as will be shown later, the effect of a rise of temperature on a young leaf is to initiate automatic response. I found that in this specimen excitation travelled a distance of 41 mm. in a centrifugal direction in 11 seconds, the temperature being 30° C. The velocity at this temperature was therefore 3·7 mm. per second. On now raising the temperature to 35° C. the time taken for transmission was reduced to half, *i.e.* 5·5 seconds. The temperature was next raised to 37° C., and the time was now found to be further reduced to 4·5 seconds, the velocity being thus 9·1 mm. per second, or nearly three times as great as at 30° C.

TABLE SHOWING EFFECT OF RISE OF TEMPERATURE ON VELOCITY OF TRANSMISSION IN BIOPHYTUM

Temperature	Distance	Time	Velocity
C.	41 mm.	11 seconds	3·7 mm. per sec.
"	41 mm.	5·5 seconds	7·4 mm. per sec.
"	41 mm.	4·5 seconds	9·1 mm. per sec.

Channels for conduction of effect of stimulus.—Before concluding this chapter, it is important to consider the channels through which stimulus is conducted with the greatest facility. Since the conduction of stimulus is due to the transmission of protoplasmic change, it is clear, as already said in a previous chapter (p. 60), that such changes will be conducted most easily along those paths in which there is least interruption of protoplasmic continuity. It is evident, therefore, that certain elements in the fibro-vascular bundles will furnish the best conducting medium for the transmission of stimulus. It also follows that in the fibro-vascular tissue itself, the conduction along the length would be more rapid and complete than across.

On the other hand, the cells of indifferent tissue, such as the parenchyma of the leaf, are divided from each other by more or less complete septa, the fine filaments by which neighbouring cells may be protoplasmically connected being so minute that the conduction of stimulus through such imperfect channels must be exceedingly feeble.

These theoretical conclusions I have been able to verify by direct measurement of conductivity in different kinds of tissue. In this investigation, as motile tests of the state of excitability were not available, I devised an electrical method—to be referred to briefly in the next chapter, and described more fully elsewhere—by which to attack the problem.

Using this method of investigation, I found that plant-organs which contained fibro-vascular elements, such as the stem, peduncle, and petiole, were the best conductors of the state of excitation, and that conduction in such organs is much greater along the length than across it; in the peduncle of *Musa*, for example, the conductivity lengthwise is three times as great as that crosswise; and finally I found that though indifferent tissues like the parenchyma are directly excitable, yet there is practically no transmission of that state of excitation through such tissue.

From anatomical and other considerations, Dutrochet and Haberlandt came to the conclusion, that it was certain ele-

ments in the fibro-vascular bundle which were concerned in transmitting the disturbance in *Mimosa*. This transmission was, however, regarded rather as a hydro-mechanical than as a true excitatory propagation. Such a conclusion, as we have already seen, appeared at one time to be probable in the light of the experiment on the transmission of excitation through a narcotised area. I have, however, already shown on p. 229, that abolition of motile excitability need not always imply the abolition of conductivity. Haberlandt describes an experiment according to which the excitation in *Mimosa* is said to have been propagated over *dead* tracts of the petiole, these portions having been destroyed by scalding. But it is extremely difficult to ensure the death of interior tissue by such means as superficial scalding. I have found that a portion of a plant-tissue when subjected locally to the action of boiling water, afterwards exhibited signs of true excitatory electric response. It is only by prolonged immersion in boiling water that one can be quite sure that the interior tissue is really killed by scalding, and unless this is done thoroughly it is easy to see that the inner cells may conduct the stimulus.

There is, moreover, another possibility, that of *pseudo-conduction*, by which the effect of stimulus might appear to be transmitted across dead areas. My meaning will perhaps be clearer if we imagine two isolated muscle-preparations, one of which is attached to a striking lever, under which is the second. Supposing stimulus to be applied to the first of these, we can see that it would cause the lever to strike the second muscle, thus causing excitation. In this way, the effect of a stimulus applied to the first muscle would appear to have been transmitted to the second, completely isolated from it. In reality, however, this was not a case of true, but of pseudo-conduction, the excitation of the second muscle being started *de novo* by the blow of the lever, itself only a secondary effect of the excitation of the first.

Similarly, we may have, in Haberlandt's experiment, two living tissues isolated from each other by an intervening area

of dead tissue. A strong stimulus applied to the first of these will now cause an excitatory expulsion of water, which will be transmitted across the dead area, and impart a mechanical blow to the second living tissue, thus setting up excitation *de novo* in that portion of the petiole.

Velocities of transmission in various plant and animal tissues.—I give below a number of determinations of velocities of transmission made with different plants, both ordinary and sensitive, the electrical method of determination having been used in the case of the former; and with this, for purposes of comparison, a series of values that have been determined in the case of animal tissues. The respective values given in the table refer to the maximum velocities obtained. In this connection, it should be remembered that the velocity of transmission depends on the intensity of stimulus. The intensity of stimulus, again, is diminished in the course of transmission through a long tract. Hence the velocity near the point of application of stimulus is relatively great, and becomes less the further the stimulus travels. In order, therefore, to make the different results comparable, my experiments have been made on equal lengths of tissue, namely, 7.5 cm. in each case, the stimulus applied being also the same.

TABLES GIVING VELOCITIES OF TRANSMISSION OF EXCITATORY WAVE

(a) *Animal*

Subject	Velocity
Nerve of <i>Anodon</i>	10 mm. per second
Nerve of <i>Eledone</i> (observed by Uexküll)	5 to 1 mm. per second

(b) *Sensitive Plants*

Subject	Velocity
<i>Mimosa pudica</i> : Petiole	14 mm. per second
<i>Neptunia oleracea</i> : Petiole	1.1 mm. ,,
<i>Biophytum sensitivum</i> :	
Petiole of direction centripetal	2.1 mm. ,,
Petiole of direction centrifugal	3.8 mm. ,,
Peduncle of	3.7 mm. ,,

(c) Ordinary Plants

Subject	Velocity
<i>Ficus religiosa</i> : Stem	9.4 mm. per second
<i>Cucurbita</i> : Tendril	5 mm. ,,
Jute : Stem	3.5 mm. ,,
<i>Artocarpus</i> : Petiole54 mm. ,,

It will thus be seen that the velocity of transmission in conducting plant-tissue is not very different from that in the conducting tissue of certain animals.

SUMMARY

Successive determinations of velocity of transmission are consistent when the stimuli are uniform, and when intervening periods of rest, sufficient for complete protoplasmic recovery, are allowed.

Velocities of transmission are not the same in centripetal and centrifugal directions. In *Biophytum*, for example, the centrifugal velocity is greater than the centripetal.

When a given point in a plant-tissue is gradually raised in excitability, the consequent excitatory discharge takes place preferentially in one direction.

Conductivity and excitability are both diminished by the increasing fatigue consequent on shortened intervals of rest. When the resting-period is shortened below a certain critical interval, the motile organ proves 'refractory' to further stimulus.

The velocity of transmission is not the same for all intensities, but increases with increasing stimulation.

The velocity of transmission is diminished by lowering, and increased by raising, of temperature.

The fibro-vascular elements are the best channels for conduction of stimulus: in them, the transmission lengthwise is greater than crosswise. Indifferent parenchymatous tissue has little or no power of conducting stimulus.

The velocity of transmission in plants is not of an altogether different order of magnitude from that in certain animal tissues.

CHAPTER XXI

ON DETECTION OF EXCITATORY PULSE DURING TRANSIT BY ELECTROTACTILE AND ELECTROMOTIVE METHODS

Pfeffer's experiment on expulsion of water from excited cells—Author's experiment on a delicate method of detecting excitatory expulsion of cell-sap—Chemical method of determining velocity of transmission of excitation—Electrotactile detector—Demonstration of passage of excitatory contractile wave by means of electrotactile method—Determination of velocity of transmission of excitation in ordinary plants by electromotive method—Excitatory *versus* hydro-mechanical movement of water.

THE fact that the excitatory wave is propagated with a constant and measurable velocity was demonstrated, with regard to sensitive plants, in the last chapter, the arrival of the wave from a distance at the motile organ being detected by means of mechanical response. As ordinary plants, on the other hand, do not possess such efficient motile indicators, some other method, more universally applicable, is necessary in order to show that in these also the state of excitation is transmitted from point to point.

Before describing the two methods which I have devised for this purpose, I shall give an account of a very interesting experiment, depending on chemical reaction, by which I have been able not only to demonstrate in a striking manner the expulsion of water from excited cells, but also to make a rough determination of the velocity of transmission. It was shown by Pfeffer that on exciting the lower side of a pulvinus, water oozes out from the cut end. On taking a detached pulvinus, and stimulating the lower surface with a blunt needle, he found that the organ curved downwards, and a drop of water was seen to escape from the cut end.

Chemical method of detecting excitatory expulsion of cell-sap.—My own experiment differs from this in several particulars. Since there is a general impression that certain specialised tissues in the pulvinus are alone excitable, it was my object to show that cells which do not exhibit any motility will also give rise to the expulsion of water by excitatory contraction, and I desired further to utilise this effect for the determination of the velocity of transmission of excitation in that tissue. The essentials to this purpose were : some means of detection of the excitatory expulsion at the exact moment of its occurrence ; some means of marking accurately the moment of application of stimulus ; and, lastly, the use of a fairly long tract of tissue, in order that the interval between application of stimulus at one end, and the manifestation of its reaction at the other, might be of a duration capable of exact measurement. For this purpose I took petioles of *Mimosa* and the non-motile stems of the same plant, and placed their cut ends in very dilute solution of sodium chloride. So dilute a solution of salt does not, as I find, appreciably affect the excitability of the tissue. Selecting one of the specimens, say a petiole, I adjusted the electrothermic stimulator at a distance of, say, 4 cm. from its lower or cut end, the specimen being held vertical by means of a clamp. The vessel of salt solution in which it had hitherto been placed was now removed. The end of the petiole was carefully rinsed, to remove all traces of salt from the outside, and a small beaker of very dilute silver nitrate solution was substituted. At this point it became necessary to finish the experiment rapidly, as silver nitrate solution is likely after a time to affect the excitability of the tissue. Momentary thermal stimulus was given by brief closure of the electric circuit. The excitation then travelled through the intervening 4 cm. of tissue, with a velocity characteristic of the plant. When it reached the cut end, the excitatory contraction produced an expulsion of cell-sap containing the salt solution previously absorbed. This expulsion was instantly made visible by the formation of a dense white precipitate

of silver chloride. This was sometimes seen to be projected as a white vortex ring. The interval between the application of stimulus and this projection was found to be three seconds.

It is thus clear that the excitatory wave is not one of hydrostatic disturbance, for such a disturbance would be transmitted with very much greater velocity. The velocity of transmission in this petiole is seen to have been 13 mm. per second, or practically the same as that obtained by a separate experiment on the fall of the leaf with similar specimens.

In a similar manner I determined the velocity of transmission through the stem. The stimulus was applied at a distance of 5 cm. from the cut end, and the chemical precipitation was observed, after an interval of five seconds. The velocity in the stem is thus seen to be 10 mm. per second. A repetition of this experiment with another piece of stem from the same plant gave similar results.

It is thus seen that cells through which excitation is proceeding undergo excitatory contraction, in consequence of which there is an expulsion of water forwards, in the direction of propagation. And this effect is produced, not in pulvinate organs alone, but in others which are not usually regarded as motile. This result is also arrived at independently by the method of electrical response.

The electrostatic method.—I shall next give an account of the much more delicate methods which I have succeeded in devising for the detection of the excitatory impulse during transit, the first of which is the electrostatic method. It is easy to understand that while the wave of excitation is passing through any given section of tissue, it must produce there certain form-changes, infinitesimal though they may be. Had our sense of touch been more delicate, we might perhaps have been able to perceive this pulse. It occurred to me, however, that it might be possible, if it existed, to obtain its indication by means of an electrical method of detection, the sensitiveness of which could be exalted at will.

As regards the pulse of form-changes we can see that two

different effects are possible. For example, in the case of muscle with parallel fibres, the wave of excitation will travel onwards from the excited point, the contraction produced giving rise to expansion of the muscle in a direction at right angles to that of propagation. In the intestinal muscle, however, owing to a different distribution of the fibres, the propagated wave is one of constriction. Now, it is clear that these two kinds of muscle, placed within enclosing contacts, will give rise, during the passage of excitatory waves, in the one case to an increase of pressure, and in the other to its diminution.

We are thus prepared to see that if similar contractile waves pass through a vegetable tissue, they may be detected by means of a concomitant variation of pressure—a variation which may prove to be either an increase, or a diminution, according to the particular disposition of the contractile elements in the tissue. If the tissue, again, should happen to be anisotropic, the same wave of contraction may appear to give rise to a diminution of pressure in one direction, and an increase in that at right angles. In any case the excitatory wave, in the course of its transmission through any given area, might be expected to produce *variation* of pressure, as between two diametrically opposite leading-points.

I am now about to describe the electrical device which I have used for the detection of such transient pressure-variations, concomitant to the passage of excitation through vegetable tissues. It is known that the electrical resistance of contact varies with pressure, and on this principle depends the construction of the microphone. But a loose contact, such as would be favourable for microphonic use, is unsuitable for our present purpose, by reason of the disturbance to which it is subject from atmospheric vibration. The necessity to be met, therefore, is that of the adjustment of an electric contact, which shall not be subject to resistance-variation from atmospheric disturbance, and which shall, at the same time, be sensitive to the pressure-variation effected by the excited tissue.

S

I overcame the difficulty regarding extraneous disturbance by using, instead of a loose, a steady pressure-contact, capable of the finest adjustment, by means of a micrometer screw. The next problem lay in choosing contact material of great sensitiveness. For this purpose I used different materials, the sensitiveness of some being very great, while that of others was moderate. Carbon contacts belonged to the latter class, but had the advantage of being easily adjustable. Various metallic powders, however, such as that of bronze, were considerably more sensitive, but at the same time required greater care for adjustment.

The most important factor in the arrangements, by which the sensitiveness of the contact may be exalted to a very high degree, lies in the proper adjustment of the electromotive force acting on the contact circuit. The sensitiveness to pressure-variation increases with increasing electromotive force, being greatest when this is just short of a certain critical value, after which the electric contact is observed to become unstable, and give rise to spontaneous oscillatory variations. For the purpose of easy adjustment of the electromotive force I use a sliding potentiometer. The tissue, say a stem of *Mimosa*, is placed between points, A and B, and by means of the micrometer screw, S, it is pressed against the spring B. The electric contact, say of carbon points, is between B and C, which are in circuit with a galvanometer, and the potentiometer. The pressure is so adjusted that a feeble current flows through the galvanometer. In order to increase the sensitiveness of the detector, the electromotive force may be gradually increased, by proper adjustment of the potentiometer, short of the critical point (fig. 106). The deflected spot of light from the galvanometer will remain steady, provided the adjustments have been properly made.

The tissue is now stimulated at a distant point, care being taken that it is not in any way jarred mechanically. Stimulation without jar is effected, however, without difficulty

by the use of the electrothermic stimulator. In any case, it is easy to discriminate between the effect of any such extraneous disturbance and the true excitatory effect in transit for which we are looking; for the effect of the former, if it

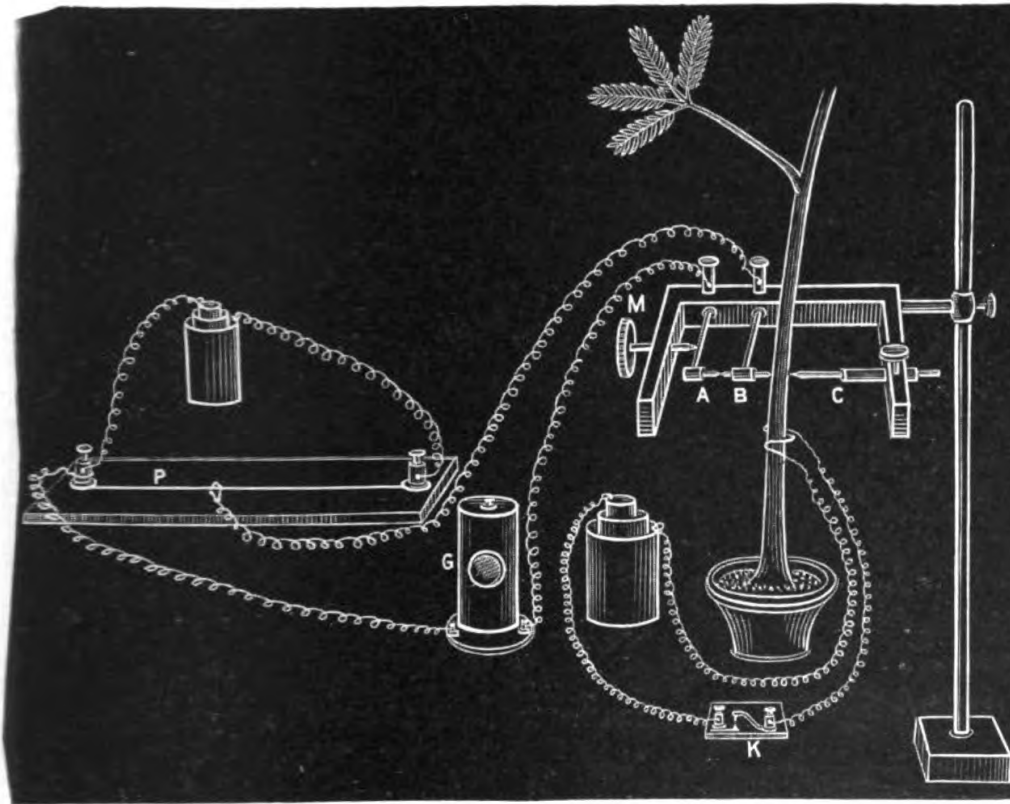

FIG. 106. Electrotactile Method for Detection of Excitatory Wave during Transit

Stem placed under light pressure between B and sliding rod C. A, B, electric contact points, the pressure of which is delicately adjusted by micrometer screw, M. A moderate current flows round the circuit, including the contact points, A B, and the galvanometer, G, the E. M. F. being suitably adjusted by the potentiometer slide, P. Stimulation of stem effected by momentary closure of key, K, in circuit with electrothermic stimulator. Excitatory wave reaching the zone B, C, causes pressure-variation, with concomitant galvanometric response.

occurs, is immediate, whereas that due to excitation takes place after a definite interval from the application of stimulus. In the experiment of which the record is given in fig. 107, stimulus was applied at a distance of 4 cm. The excitatory wave reached the experimental zone after an interval of five

S 2

seconds, and indicated its presence by a diminution of pressure on the contact (fig. 107), resulting in sudden diminution of current. After the passage of the excitatory wave the tissue was restored to its original condition, as shown by its once more exerting its normal pressure. This process of response and recovery by variation of pressure is exhibited by the galvanometer record. The recovery is usually found to be attained in the course of a half to one minute, according to the intensity of stimulus. As the result of this experiment, we find the velocity in this particular

stem to be 8 mm. per second, which is very near the determination already made by other methods, with different specimens of stem of *Mimosa*.

Frequently as I have obtained this response during transit by diminution of pressure, its opposite, that is to say, response by increase of pressure, is by no means uncommon. I have already explained how it is possible for excitatory contraction to give rise to two such opposed effects, in consequence either of different dispositions of the contractile elements in the tissue, or by the presence of anisotropy in the organ. By means of the electro tactile method, then, we are able to demon-

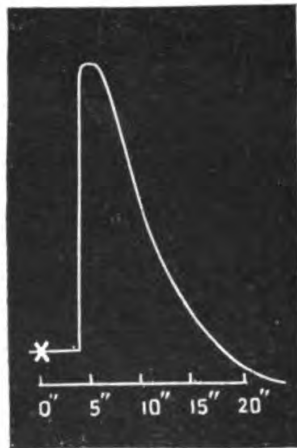

FIG. 107. Electrotactile Response in Stem of *Mimosa*

Stimulus applied at the moment \times , at a distance of 4 cm. below the detector.

strate the passage of the excitatory wave, and also to measure its velocity, in tissues which are not motile.

The electromotive method.—I shall now describe the second, or electromotive, method which I have used for the detection of the excitatory wave during its passage through a vegetable tissue. I have already explained that when the plant-tissue is directly excited, the state of excitation is invariably accompanied by an electromotive variation, the excited point becoming galvanometrically negative (p. 32). Hence, when an excitatory wave is transmitted through the

tissue in any direction, from the stimulated point, there must always be an electromotive wave as its strict concomitant. The moment, therefore, when the excitation reaches a given point may be determined by observing the arrival of this excitatory electrical disturbance of galvanometric negativity, and for the detection of such an excitatory wave the galvanometer takes the place of the motile leaflet.

In order to prove that the excitatory mechanical and electrical effects are strictly concomitant, it is only necessary

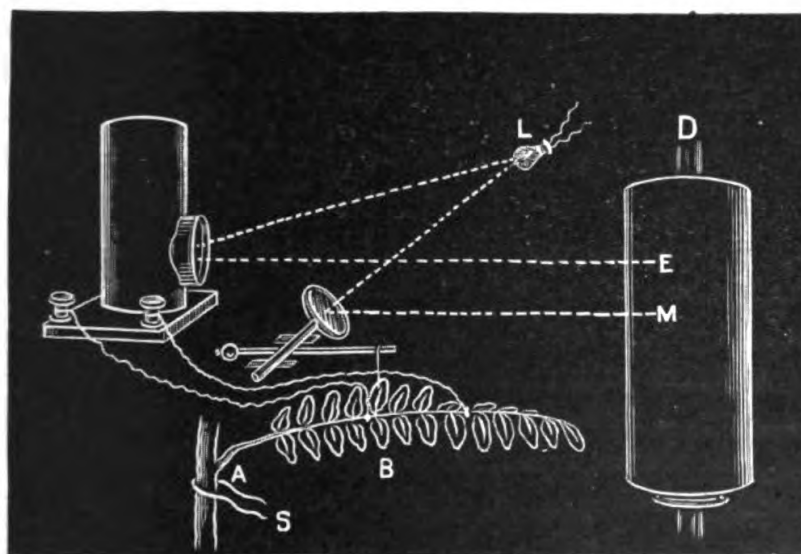

FIG. 108. Experimental Arrangements for Simultaneous Recording of Mechanical and Electrical Responses

Stimulus applied by thermo-electric stimulator, *s*, at *A*. Excitation reaching *B* causes mechanical response of leaflet, which is recorded by optical lever on drum at *M*. Simultaneous galvanometric negativity recorded at *E*.

to perform an experiment on a plant, such as *Biophytum*, which is provided with motile leaflets. We attach one of the indicating leaflets to the Optic Lever, and connect its base *B* with one of the electrodes of the galvanometer, the second electrode of which is connected with a distant point of the leaf (fig. 108). The two spots of light, one from the Optic Lever indicating mechanical, and the other from the galvanometer indicating electrical, response are adjusted to lie

one above the other on the same revolving drum. On applying a stimulus, say thermal, at A, it will be found, after the lapse of a definite interval, that both spots of light are deflected simultaneously, proving the concomitance of the mechanical and electrical effects. Such a record has been given already, in fig. 26. If we make a mark on the revolving drum at the moment of the application of stimulus, and a second mark when the electrical (and, in this particular case, also the mechanical) response is initiated, we can, with the previous knowledge of the speed of the drum, determine the time taken by the excitation to travel from A to B, and thus find the velocity of transmission for that specimen by electrical means.

A further refinement of this method lies in the use of two galvanometers instead of one, the slight lag of response, caused by galvanometric inertia, being in this way eliminated. Particulars regarding this will be found elsewhere.

It will be seen, then, that in the electromotive method we have a second means by which to determine the velocity of transmission of excitation in what are known as ordinary plants. I shall now describe experiments performed by this method. The peduncle of *Biophytum* is leafless. That it does transmit stimulus is seen nevertheless when we excite it at any point. Excitation will then be found transmitted through it to the main stem, from which it travels outwards to different leaves, a fact evidenced by the serial fall of leaflets in a centrifugal order. In such a peduncle I have determined the velocity of transmission by the electromotive method. The distance between the points A and B was 4.6 cm.; the time taken for transmission was 12.7 seconds. The velocity is thus found to be 3.7 mm. per second.

Similarly, in the stem of *Ficus religiosa*, I found velocity of transmission to be 9.4 mm. per second, which is almost the same as that in the stem of the so-called 'sensitive' plant *Mimosa*.

From the experiments carried out on the electrotactile method it will be seen that excitation is conducted along a plant-tissue from cell to cell, as a contractile wave. We

have also seen that water is expelled from an excited and therefore contracted cell. It is further clear that when an excitatory wave is proceeding in any direction, this cell-to-cell passage of excitation will give rise to a cell-to-cell contraction, the result of which will be a forward movement of water, which will have the velocity, not of hydrostatic transmission, but of the excitatory wave. The hydrostatic disturbance is quite distinct, being transmitted with great rapidity, and its presence has been shown in the preliminary abnormal response of erection in leaflets of *Biophytum* (p. 24). But that propulsion of water which is concomitant to the passage of true excitation is very much slower, having the same speed as that of excitation itself.

SUMMARY

The direct effect of stimulus is not transmitted by means of hydrostatic disturbance, but by a cell-to-cell propagation of excitation.

This transmission of excitation from cell to cell is attended by a cell-to-cell contraction.

The passage of such a contractile wave may be detected by the electrotactile method, which thus enables us to determine the velocity of transmission of excitation, even in tissues which are not motile.

In consequence of the concomitance of the excitatory wave with cellular contraction, water is moved forward progressively, with a velocity and in a direction the same as that of excitation.

This movement of water is not brought about by any hydro-mechanical action, but is the direct effect of the contractile wave due to excitation. The hydrostatic disturbance, when present, is transmitted with very great velocity, and its effect is seen in the abnormal preliminary response of erection, exhibited, for example, by the leaflets of *Biophytum*.

The velocity of transmission of excitation in ordinary plants may also be found by determining the velocity of the concomitant electromotive wave.

CHAPTER XXII

THE LATENT PERIOD AND REFRACTORY PERIOD

The determination of the latent period in *Mimosa*—Experimental arrangements for obtaining automatic record—Prolongation of latent period by cold—Spark-record for determination of latent period—Prolongation of latent period by fatigue—Sluggishness of the response of *Philanthus uriniaria*, also long latent period and very protracted period of recovery—Latent period reduced under strong stimulation—Response in *Biophytum* on the 'all or none' principle—Definite value of effective stimulus—Phenomenon of refractory period in *Biophytum*—Parallelism of responses in *Biophytum* and in cardiac muscle—Additive effects—Inappropriateness of term 'refractory period'—Energy in excess of effective stimulus held latent for subsequent manifestation.

HAVING explained the means by which it is possible to apply a quantitative stimulus of uniform or increasing intensity, and also how the responsive effect and its time-relations are accurately recorded, we shall next turn to the study of the various characteristics of the response itself, as given for example by the plant *Mimosa* or *Biophytum*. In order that we may inspect different parts of the response-curve in greater detail, it will be necessary to take the record on a fast-moving drum, so that the curve may be drawn out, and its several features more easily distinguished. As we wish, moreover, to study the excitatory effect on the motile organ, stimulus will be applied directly on the pulvinus.

Automatic method of record.—As it will be necessary in the course of the following investigation to measure the times of reaction accurately, to small fractions of a second, the record must be obtained automatically. It is to be remembered that, as said before, response in vegetable tissues is relatively more sluggish than in animal, and it is superfluous to arrange for measurements of time up to more than

hundredths of a second. The experimental method that I am about to describe would, however, enable us, if necessary, to make determination of time-intervals of one-tenth this magnitude, the question being only one of using a recording drum with the requisite increased speed. The drum used for these experiments was one constructed by Verdin, and provided with a very perfect governor. Some little time elapses after starting the drum before it acquires uniform speed, which it afterwards maintains, however—at least during the short time required for the experiment—with great perfection. The record is not taken until this uniform condition is attained. The mirror of the Optic Lever throws a spot of light upon a sensitive photographic film, wrapped round the revolving drum. In order to produce records of the required rapidity, I employ sunlight, proceeding from a pinhole, which after reflection from the mirror of the Optic Lever falls on the drum, appropriately focussed by means of a condensing lens placed at the end of a focussing tube, as seen in the figure. It is understood that, the record to be obtained being photographic, this experiment is carried out in a dark room, the sunlight required for the record being directed upon the pinhole by a heliostat outside.

The stimulus consists of a single strong break-shock, from a Ruhmkorff's coil, one electrode of which, by means of non-polarisable connections, is attached to the pulvinus of a leaf, and the other to the main stem lower down, of a specimen of *Mimosa*. The shock is applied by the recording drum itself, at a particular moment in the course of its revolution; and at the same instant the curve of response begins to record itself automatically. These two acts—of imparting stimulus, and of opening a shutter by which the recording ray of light is allowed to fall upon the moving film—are performed simultaneously; and both alike are initiated by the stroke of a rod which is fixed to the axis of the drum underneath.

This rod, which I shall designate as the striker, at a certain period in the revolution of the drum, impinges upon a balanced

electric key, κ_1 , thus closing an electro-magnetic circuit, and so releasing the shutter s , which is immediately in front of the pinhole, by which sunlight is admitted. This drop of the shutter, simultaneously producing a break of the Ruhmkorff's coil circuit, gives an excitatory electrical shock to the plant.

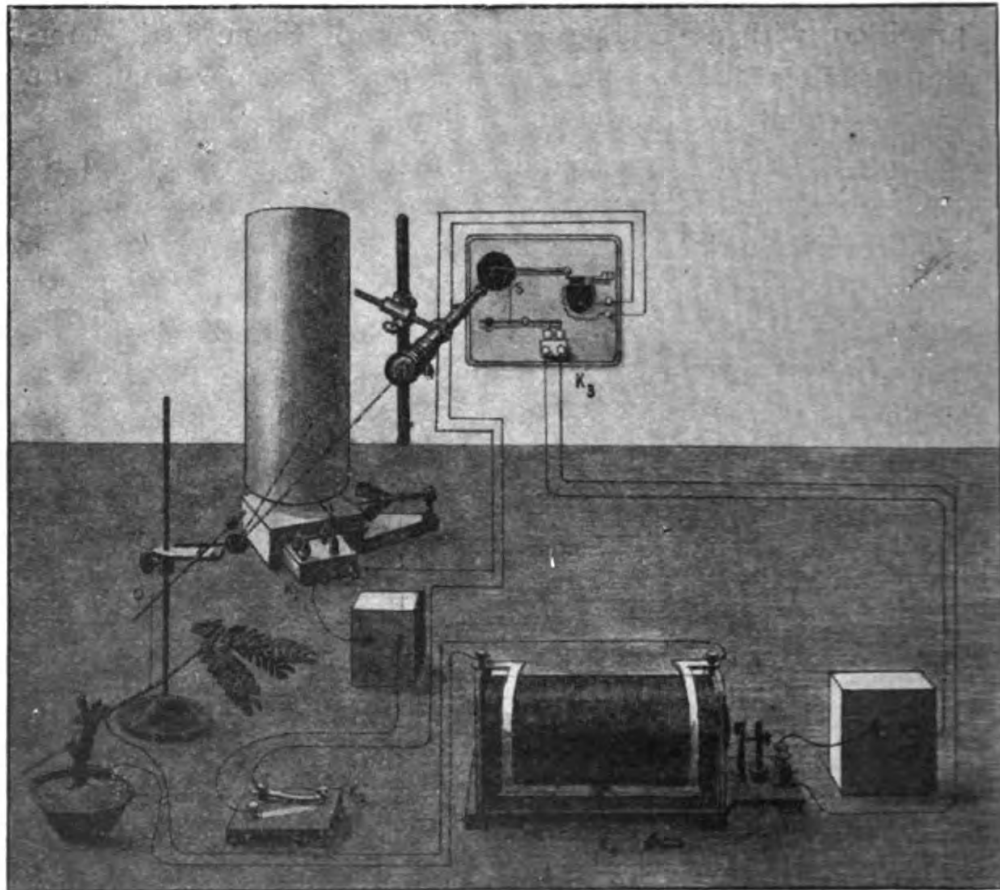

FIG. 109. Apparatus for Automatic Record

When the speed of the drum has become uniform, κ_2 is closed, and the striker, in connection with the drum, closes the electro-magnetic shutter circuit. The dropping of shutter, s , interrupts by κ_3 the primary circuit of the induction coil, the secondary of which gives a shock to the plant. The fall of the leaf pulls down the Optical Lever, o , producing record on drum. κ_4 , short-circuiting key of secondary.

The electro-magnetic circuit of the shutter is interrupted by a key, κ_2 , and this is kept open till the speed of the drum has become uniform. On closing κ_2 , the circuit is still incomplete; but the striker, impinging against the

balanced key, K_1 , completes the circuit, and actuates the shutter.

A thread connects the shutter with one arm of a second balanced key, K_3 . This arm is so overweighted that when freed, it causes two prongs, at the opposite extremity of the lever, which complete the primary circuit of the Ruhmkorff's coil, to be lifted out of their cups of mercury, and thus the circuit is interrupted. But the thread is of such a length that when the shutter is set, so as to close the pinhole, the prongs, dipping into the cups of mercury, complete the primary circuit. The overweighted arm of K_3 falls, with the drop of the shutter lifting up the prongs, and thus suddenly interrupts the primary current, giving rise to a break-shock in the secondary, which passes through the plant. During the course of the preliminary adjustment, when primary circuit of the coil is made, a make-shock is produced, but this is prevented from affecting the plant by a key, K_4 , which short-circuits the secondary. When the adjustment has been made, this short-circuiting key is opened.

Briefly to recapitulate the procedure: The drum, carrying the sensitive film, is released, and begins to revolve. The key K_2 of the shutter-circuit is kept open, until a uniform speed is attained. It is then closed. The striker connected with the drum now closes the balanced key, K_1 ; the shutter drops, and simultaneously interrupts at K_3 the primary current of the induction coil, thus causing an excitatory shock to be given to the plant.

The determination of the latent period.—It will be seen from the upper of the two photographs, given in fig. 110, that for a period of $\frac{2.4}{100}$ of a second the record remains horizontal. This represents the latent period, after which the tissue begins to respond. For a further period of half a second the leaf is seen to fall with a considerable and approximately uniform speed. The rate of movement of the tip of the leaf is now 71 mm. per second. After this the leaf continues to fall, but with a diminishing speed, till the maximum contraction fall is reached. From records obtained on

slower-moving drums, I find that this is attained in different specimens, in a period of 1.5 to 2.5 seconds after the shock. This maximum contraction persists for a further period of about thirty seconds. The leaf now begins to erect itself, and full recovery is attained in the course of a further period of about six minutes. These statements refer to reaction in vigorous *Mimosa*, at a favourable season of the year, like summer. In an unfavourable season, like winter, however, the reaction becomes very sluggish, and recovery is not then

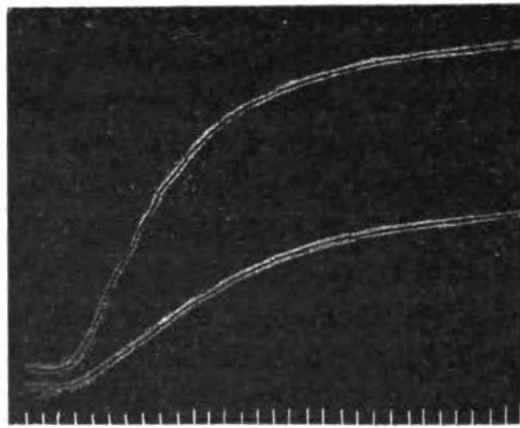

FIG. 110. Photographic Record of Response of *Mimosa*, Exhibiting the Latent Period in its Variation

The upper curve was taken under normal conditions, and the lower when the pulvinus was slightly cooled. Time-marks = tenths of a second. Original record reduced to half.

[The duplication, which will be observed in each record, is due to the fact that the heliostatic mirror was silvered behind, thus producing two reflections, one from the surface of the glass and the other from that of the silver.]

complete in less than eighteen minutes, or three times the normal period.

Effect of cold on latent period.—I shall next refer to the sluggishness induced by cold, prolonging the latent period. The extreme instance of this is seen when iced water is applied to the pulvinus, and too great cooling being thereby effected, the response is abolished. With moderate cooling the latent period is found to be prolonged to several seconds. This effect cannot conveniently be shown, however, within the limits of a fast record. In order, therefore, to show the comparative effect of cold on the latent period, in the case of the same specimen whose record is seen in the upper of the two photographs in fig. 110, I was careful to cool the pulvinus very slightly. In the lower of these photographs it will be seen that the latent period has become prolonged, from the normal $\frac{2.4}{100}$ to $\frac{3.0}{100}$ of a second.

complete in less than eighteen minutes, or three times the normal period.

Effect of cold on latent period.—I shall next refer to the sluggishness induced by cold, prolonging the latent period. The extreme instance of this is seen when iced water is applied to the pulvinus, and too great cooling being thereby effected, the response is abolished. With moderate cooling the latent period is found to be prolonged to several seconds. This effect cannot conveniently be shown, however, within the limits of a fast record.

The rate of responsive movement is also seen to have undergone considerable diminution. In the first, or normal, case, during half a second after the commencement of response, the rate of movement was, as said before, 71 mm. per second. In the second case, however, after slight cooling, it is seen to have been reduced to 26 mm. per second, or almost one-third of the original rate.

Record by means of electric sparks : prolongation of latent period by fatigue.—In order to overcome the difficulty of the insensitiveness caused by keeping the plant in a photographic dark room, I have recently devised a method of

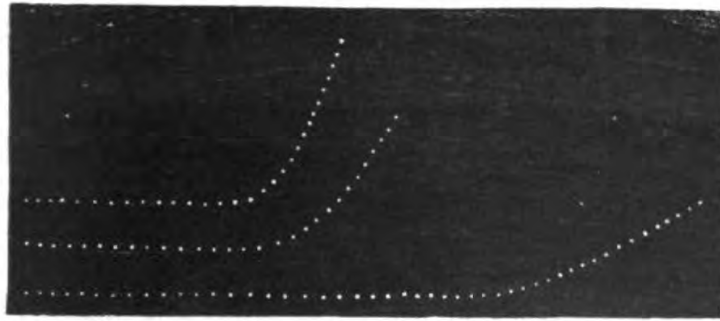

FIG. III. Electric Spark Record, Showing Increase of Latent Period by Fatigue, in Successive Responses of a Leaf of *Mimosa*

Latent period in normal topmost record seen to be $\frac{28}{100}$ second ; this increased in next—taken 1 minute before full recovery—to $\frac{30}{100}$ second ; latent period further increased in last case—taken 3 minutes before full recovery—to $\frac{58}{100}$ second. Note also progressive change in slope of curve.

record by means of a series of punctures produced by electric sparks on a recording paper surface. The sparks occur at the short gap between the end of the long arm of the recording aluminium lever, and the drum, these being connected respectively with the two electrodes of a Ruhmkorff's coil. The electrical disturbance does not affect the plant, as the leaf is attached to the lever by a long silk thread. One great advantage of this method lies in the fact that the time-intervals, which may be as short as desired, are indicated by the distance between successive punctures, which are determined by the frequency of the vibrating interrupter of the coil. In the case of which the record is given (fig. III) the

interval between successive sparks was $\frac{1}{50}$ of a second. By this means, it was found that increasing fatigue induced a corresponding increase in the latent period of a leaf of *Mimosa*, from the normal $\frac{2.8}{100}$ to $\frac{5.8}{100}$ of a second.

Response of *Biophytum*.—I shall now proceed to describe effects essentially similar to the last, seen in *Biophytum*. In order to be able to observe in detail the various responsive peculiarities of the curve, subsequent to stimulation, records were taken in this case on a much slower-moving drum. The record given in fig. 112 shows the mechanical response to stimulation produced by discharge of condenser (capacity .01

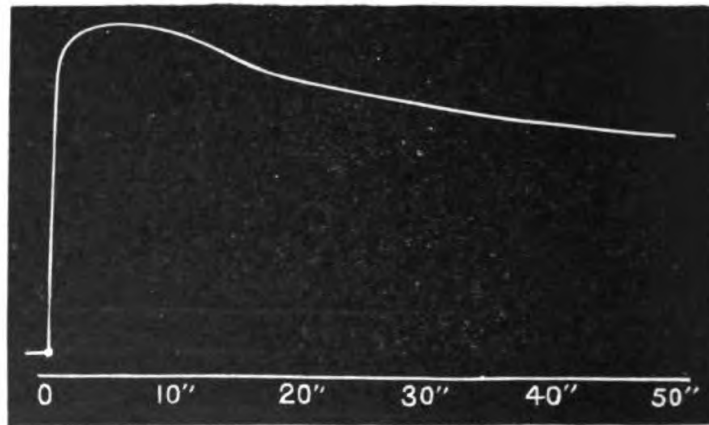

FIG. 112. Response of *Biophytum*; Electrical Stimulus having been Applied at the Pulvinus of the Motile Leaflet
The thick dot represents the moment of stimulation.

microfarad, charged to nine volts). The exact moment of stimulation is marked on the record.

It will be seen that the leaflet begins to respond almost instantaneously. The maximum contraction in this case, being considerably more rapid than in that of *Mimosa*, is almost attained in the course of half a second. An interesting point to be noticed in the record is the flattening of the top of the curve (fig. 112). That is to say, the maximum contraction persists for a considerable time before recovery begins. In the present case this lasted for ten seconds. This period varies in different specimens, from a maximum of ten to about two seconds. But in this particular specimen the period

in question remained at least approximately constant, in successive experiments. After this there was commencement of recovery, which was completed—as seen by the return of the spot of light to its exact original position—in the course of five minutes. In order to form an idea of the consistency of results which may be expected from a good specimen, I repeated this experiment six times in succession, commencing the record each time at the same point on the recording surface as before. The degree to which all these curves coincided with each other in detail is almost incredible. Their rising portions, their flat tops, and their gradual descent during recovery, were all so coincident that the six successive curves appeared as but one.

In specimens of plants which were not in good condition, fatigue was shown by the gradual diminution in height of successive responses. For accurate standard experiments it is therefore necessary to have specimens which are vigorous.

We have already seen the prolongation of the latent period which is induced by cold, in the case of *Mimosa*. I have obtained similar results also in working with *Biophytum*. For example, in a certain experiment, moderate cooling induced a prolongation of two seconds in the latent period. When the plant was allowed to return to the surrounding temperature of the room, however, the increase of latent period disappeared.

Latent period diminished by increased intensity of stimulus.—It has been said before that there are innumerable gradations between the extreme cases of motile sensibility in plants. As regards motility, an extremely sensitive leaflet was that of *Mimosa pudica*. Somewhat less quickly reacting were those of *Biophytum sensitivum*, and we had in the leaflets of *Philanthus urinaria* an instance of extreme sluggishness.

The latent period of the leaflet of *Philanthus*, under moderate stimulus, is as long as three minutes, and the maximum contraction is not attained under forty minutes; but with a stronger stimulus the latent period is reduced to less

than one minute, and the maximum contraction takes place in a relatively short period of about fifteen minutes (fig. 30, *b* and *c*, p. 44).

Response of *Biophytum* on the 'all or none' principle.

It is well known that in the case of a contractile skeletal muscle, there is a minimal intensity of stimulus which is necessary in order to produce contraction. From this point onwards, as the stimulus is gradually increased, the response increases, till a maximum contraction is arrived at, beyond which still further increase of stimulus produces no increase in effect. In cardiac muscle, however, the range of stimulus between minimal and maximal is practically narrowed to a point, so that the minimally effective stimulation is also at once maximal. It is to be remembered, at the same time, that the differences between cardiac and skeletal response are a question of degree, rather than of kind.

Curiously, the response of *Biophytum* is, in this respect, somewhat similar to cardiac response. In an experiment with a particular specimen of *Biophytum*, the intensity of stimulus was increased by successive increments of the E.M.F. used for charging the condenser. With an E.M.F. of seven volts there was no response. With a charge of nine volts there was always a response, and this was maximal. A charge of eight volts was almost on the threshold of response. That is to say, when I started experimenting, the leaflet was in a somewhat sluggish condition, and an eight-volt charge was ineffective. But after obtaining response to a nine-volt charge, I could obtain response also at eight volts. This was due to the fact that molecular inertness had been removed by the preceding effective shock. Thus we have two determinate values of stimulation, giving respectively maximum response and absence of response, the charges, namely, of nine and seven volts. The effective stimulus is, of course, constant for a given individual, but differs with the excitability of different specimens. Here, then, we have an instance of the 'all or none' effect. The leaflet either responds to the utmost, or not at all.

Refractory period.—We shall next consider the peculiarities of the refractory period which I have discovered in the case of plant-tissues ; and for the material of this investigation we shall use the plant *Biophytum*, taking, in fact, the very specimen whose successive responses have already displayed such remarkable consistency (fig. 112). Such uniformity in successive responses is only possible when we allow sufficient time of rest for complete protoplasmic recovery, by which the excitability is fully restored. But it has been shown in Chapter XX. that if sufficient time of rest be not allowed, the protoplasmic recovery is incomplete, and the excitability is diminished. Hence the extent of response, which is an outward indication of excitability, is diminished, and this effect is known as *fatigue*.

We also arrived, in the same chapter, at the theoretical conclusion that there is a minimum resting interval, the diminution of which results in such a loss of excitability as to abolish response, and this period we know as the Refractory Period, because the leaf then apparently takes no account of stimulus, or is 'refractory' to it (fig. 105). We shall now enter into greater detail regarding the peculiarities of this refractory period. After taking the six curves in response to separate single stimuli which were so extraordinarily similar, I proceeded to take a curve of response to two equal stimuli of the same intensity as before—namely, nine volts, charging 01 microfarad—the two stimuli following each other at an interval of one second. The application of the second stimulus appeared to produce no effect, the extent and general character of response being the same as in the case of single stimulus, with only the difference of a slight elongation of the flattened top of the curve. I next tried the effect of two stimuli at an interval of five seconds. The leaflet was still refractory to the second stimulation, but when I applied it at an interval of ten seconds, the second stimulus became effective. It will thus be seen that *Biophytum* has rather a long refractory period, during which, as far as can be seen, it takes no account of the impact of a new stimulus. This refractory

T

period is a matter of several seconds, but varies somewhat with different specimens. I have, again, in some cases observed a very curious phenomenon of two refractory periods.

We thus find several very interesting parallelisms between the response of *Biophytum* in plants and that of cardiac muscle in animals. We find in both that the minimal response is also the maximal, increasing stimulation producing no increase of response.

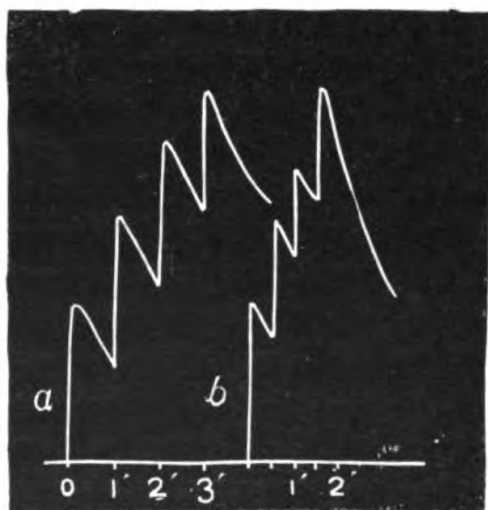

FIG. 113. Additive Effects seen in Responses of *Biophytum* to Stimuli which Fall outside the Refractory Period

The record to the left shows the effect of stimuli, applied at intervals of one, and that to the right of half a minute.

are not additive, perhaps because that muscle undergoes the maximum contraction possible. In *Biophytum*, however, while any effective stimulus—whether minimal or largely super-maximal—will produce response of the same extent, yet this response, though the greatest possible for a single stimulus, is not the utmost of which the leaflet is capable. Hence, if we superpose successive stimuli, taking care that they do not fall within refractory periods, we shall obtain an extremely interesting response, showing the separate additive effects. I give here two curves, exhibiting these

In the response-curve itself the flattened top is common to both; both have a prolonged refractory period; and we shall see later that in both there is a tendency to the production of multiple rhythmic responses.

In all these respects the responses of *Biophytum* resemble the cardiac responses, rather than those of skeletal muscle. But they have one peculiarity in which they share the characteristics of the responses of skeletal muscle. In the responses of cardiac muscle, successive effects

effects of superposition of stimuli. In the right-hand record in fig. 113 the stimuli were applied at intervals of thirty seconds. The successive responses, except the last, show a regular decrease. In the left-hand record, successive stimuli were applied at intervals of a minute, and appear much more equal.

But even in these additive effects we find one peculiarity which is also characteristic of cardiac response. In the latter case, though on repetition of stimulus there is no summation of height of response, yet the apex-time of the second response is shorter than that of the first. We see this in the case of *Biophytum*, in the right-hand curve. The first response has a slightly rounded top, but this is reduced to an acute angle in the second. The record, having been reduced to one-eighth for reproduction, does not show this so plainly as does the original.

Though each single response of *Biophytum* is maximal, yet from fig. 113 we have seen that this maximal response does not represent the utmost movement of which the leaflet is capable. In the particular plant here used for experiment, the maximal response to individual stimulus was always about thirty-eight divisions, but four superpositions produced a total movement of ninety-four divisions. It must be remembered that such effects can only be possible when the second stimulus is timed to fall at the expiration of the preceding refractory period.

If the absolute value of each individual minimally effective stimulus be represented by s , and if the whole be added together, or, in other words, if a stimulus of $4s$ be given at once, we may regard such a stimulus as made up of one minimally effective, *plus* three others which fall within the refractory period, and are thereby rendered totally ineffective. In other words, we may regard a very strong stimulus as made up of so many minimally effective stimuli. It is as if the first effective fraction alone acted, the succeeding portions, which arrive within the refractory period, being inoperative.

T 2

In view of certain other phenomena not altogether disconnected, it seems unfortunate that the term 'refractory period' should be used with its present significance. For this term might be held to imply that the tissue refuses to take any account of the superfluous energy that is impressed upon it. It is more likely, however, that by some peculiar mechanism, the superfluous stimulus—*i.e.* what is over and above the amount necessary for producing maximal response—is prevented from overflowing. This excess of energy may, then, at least in some cases, remain latent, to be manifested at a later period in the form of excitatory impulses. Such impulses, again, attuned by some regulating process, may give rise to periodic or rhythmic overflow. That this is actually the case will be demonstrated in the next chapter.

SUMMARY

The latent period of response is protracted by cold. It is also protracted by fatigue. It is shorter under strong, than under moderate stimulation.

In vigorous specimens of *Biophytum* leaflet, the minimally effective stimulus is also maximal; under normal conditions, this minimally effective stimulus has a definite value.

There is also a definite refractory period in the response of *Biophytum*. If a second stimulus fall within this refractory period, it appears to produce no effect.

The response of the leaflet of *Biophytum* resembles in many respects that of cardiac muscle. In both, response is on the 'all or none' principle, and both exhibit a relatively long refractory period.

PART IV
MULTIPLE AND AUTONOMOUS
RESPONSE

CHAPTER XXIII

ON MULTIPLE RESPONSE

Multiple electromotive responses due to a single strong stimulus—Multiple electro tactile responses—Multiple mechanical responses in *Biophytum*—Cyclic variations in multiple responses—Multiple retinal excitations—Intermittent pulse in man and plant—Semi-automatism—Continuity of multiple and automatic response—Conversion of *Biophytum* into automatically responding plant ; conversion of *Desmodium* into ordinarily responding plant—Similar polar effects of current in *Biophytum* and in *Desmodium* leaflet, at standstill—Moderate stimulus in *Biophytum* and in *Desmodium* at standstill produces single response ; and strong stimulus, multiple response.

I HAVE already explained in Chapter III. that the excitatory wave initiated by a stimulus has a concomitant electromotive wave. If the plant experimented on is provided with motile leaves or leaflets, the excitation is evidenced by the simultaneous mechanical response of the motile organ, and the electrical response of galvanometric negativity.

Multiple electromotive responses due to single strong stimulus.—In my investigations on electrical response in plants, I was surprised to find that whereas a single moderate stimulus gave rise to a single electrical response, a very strong stimulus very often initiated a multiple series of responses. I have obtained such multiple responses to a single stimulus with all kinds of plants, ordinary and 'sensitive,' and under the action of various forms of stimulus—chemical, thermal, and mechanical.

To obtain these multiple electrical responses in an unmistakable manner it is necessary that the excitation should reach one electrical contact and not the other, for in the latter case there would be complications arising from diphasic variation. The necessary condition may be fulfilled by

applying stimulus near the proximal contact, the other contact being at a relatively great distance. The periodicity of these multiple electric responses I find to vary in different

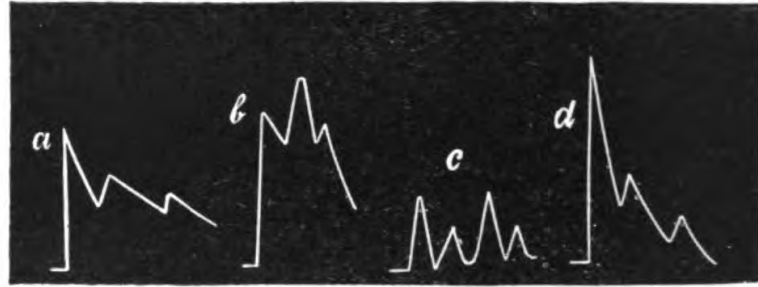

FIG. 114. Multiple Electrical Responses due to Single Strong Stimulus

(a) In *Mimosa* due to thermal, and (b) to chemical stimulation; (c) in peduncle of *Biophytum*, due to thermal stimulus. [N.B.—This series persisted for two hours.] (d), in hypocotyl of *Tamarindus indica*, due to stimulus of cut.

cases from about a half to five minutes. These multiple electrical responses, resulting from a single strong stimulus, sometimes persist for as long as two hours (fig. 114).

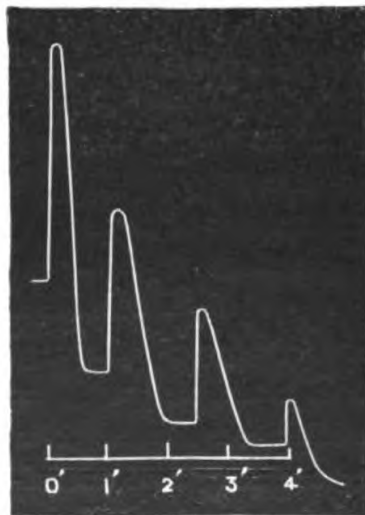

FIG. 115. Multiple Electrotactile Response in Stem of *Mimosa*, due to Single Strong Thermal Stimulus

(Original record reduced to $\frac{1}{3}$.)

Multiple electrotactile responses.—In the course of my experiments on the electrotactile method of detecting the excitatory wave, I discovered multiple waves, initiated by a single strong stimulus, passing through the tissue. In fig. 115 I give a record of such multiple responses in the stem of *Mimosa*, in which it will be seen that there are four such responses, with an average period of one minute each.

Now, as these pulsations are signs of the presence of excitation, it follows from the occurrence of such multiple responses that a strong stimulus may give rise to a multiple series

of excitations. I was therefore led to expect that this fact might be demonstrated in another and still more convincing manner, if I should succeed in finding a sensitive plant which exhibited these multiple excitatory waves by repeated movements of the indicating motile leaflets.

Certain peculiarities of *Biophytum* which I had previously discovered led me to think that I might find in this plant the opportunity I sought; for we have seen in the last chapter that in *Biophytum* a certain minimal intensity of stimulus induced the maximal mechanical response. With such a stimulus we obtain only one response, and if we apply a stimulus of very much more than minimal intensity it produces no greater mechanical effect. What, then, happens to the excess of stimulus? This excess may be wasted as heat, or it may continue to exist in some latent form, and this latent stimulus may subsequently be given out rhythmically.

Multiple mechanical responses.—In view of these facts I expected a strong stimulus to give rise to those periodic waves whose existence I had been led to suspect from the observation of the recurrent electromotive and electrotactile waves in various plants. As a matter of fact it has been noticed that *Biophytum*, when strongly excited, exhibits two successive movements of mechanical response, the leaflets not completing their closure at once, but in the course of two twitches succeeding each other. But I expected to detect a larger number of pulsatory movements in response to a single strong stimulus.

In order to do this, however, it was necessary to prevent the complete closure of the leaflets, by which the further exhibition of mechanical response was made impossible. For this purpose I used the Optic Lever, with the light counterpoise (p. 19). In this way I succeeded in demonstrating, through mechanical response, what had already been demonstrated electrically, the fact that a single strong stimulus, of whatever form—thermal, mechanical, electrical, or photic—will induce, not one but a multiple series of

rhythmic responses in a plant. Thus on applying a thermal stimulus to the petiole of *Biophytum* near its insertion on the stem, an excitatory wave was found, as usual, to produce successive depressions of leaflets in a centrifugal order. But after a while the existence of a second excitatory wave became evident, by a second series of closures of leaflets. That the wave was due—not to excitation reflected in some way from the tip of the leaf, but—to a second wave starting from the original point of stimulation, was made evident by the fact that the successive fall of leaflets was again centrifugal, from near the stem to the tip of the leaf. From the records now obtained by means of the Optic Lever, attached to one of the leaflets, it was interesting to observe the very numerous rhythmic pulsations, often as many as twenty, now made visible.

As an instance of the simplest form of such multiple response, I give the following record, which was obtained under the thermal stimulation of the electrothermic stimulator. The point of application was close to the responding leaf. The average period of these pulsations was about thirty seconds (fig. 116). It may be stated here that the period of multiple responses of *Biophytum* is found to vary from about fifteen seconds to three minutes or so, depending on the condition of the plant and the intensity of the stimulus.

The question suggests itself, since multiple electromotive and electrotactile excitations are observed in *Mimosa*, why should not this plant also exhibit them mechanically? The answer to this is probably found in the fact that the *Biophytum* leaflet is light, and easily exhibits fluctuating impulses, whereas the impulsive fall of the heavier *Mimosa* leaf persists, owing to greater momentum, till it is more or less complete. Again, unless an organ has at least partially recovered from fatigue, it is not susceptible of fresh excitation. The period of full recovery in the pulvinus of *Mimosa* is very long, being about seven minutes. We saw, in studying fatigue in

Mimosa, that when a second stimulus succeeds a first, after an interval of less than one minute, it produces no responsive effect. If, then, a second wave of excitation arrives within the refractory period of the first, we must expect that it will remain mechanically ineffective. In the multiple electro-tactile responses seen in fig. 114, these successive excitations are seen to have occurred at intervals of one minute, complete recovery being accomplished in that time. In the

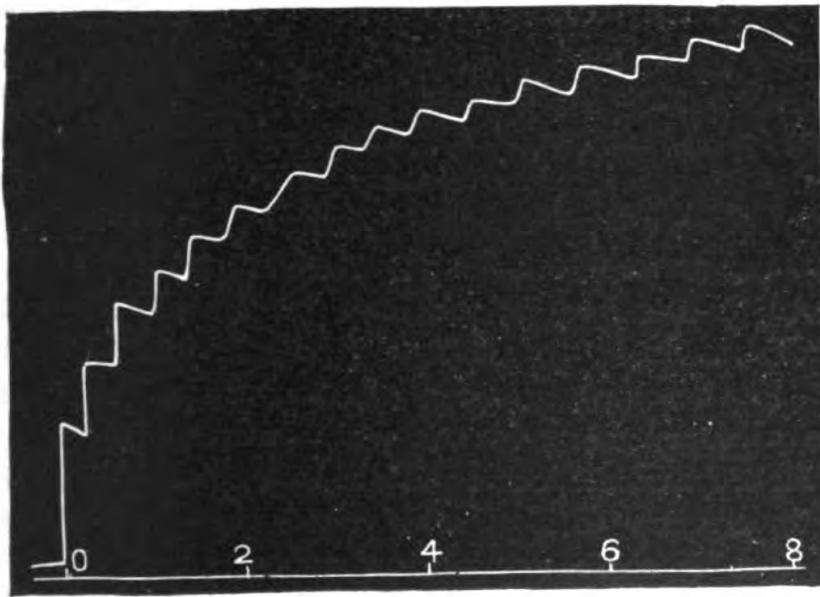

FIG. 116. Multiple Mechanical Response of *Biophytum*, due to a Single Thermal Stimulus

stem, then, the period of recovery is very much shorter than in the pulvinus, and the same waves of excitation which at intervals of one minute produce response in the one case, prove ineffective in the other. Had these periodic waves of multiple excitation been three or four times as slow as they are, we might have been able to observe multiple mechanical responses of the leaf of *Mimosa*. In connection with this, I may state that I once observed a second mechanical response to a single strong stimulus

in the leaf of *Mimosa*. In this case the second response occurred four minutes after the first.

We have seen that multiple electrical response is obtained when any form of strong stimulation is employed. I now tried to find out whether multiple mechanical response could be produced by chemical stimulation. One of the middle leaflets of a *Biophytum* leaf was attached to the recording Optic Lever, and I applied a drop of sulphuric acid 1 cm. away from the recording leaflet in the direction of the tip of the leaf. This was found to give rise to five vigorous recurrent pulsations.

Thus, though a single moderate stimulus evokes but a single response, yet under strong stimulation we obtain not only the immediate consequent response, but also a surplus of energy which remains over and is held latent in the tissue, to be given out later, after a shorter or longer interval, in the form of recurrent responses. From these experiments it is clear that a rhythmic series of effects need not have a periodic antecedent cause. As regards these pulsatory movements, it was shown on page 47 that the fall of the motile leaflet was due to a pulse of diminution, and its erection to a pulse of restoration, or increase, of turgidity. In these multiple responses, then, we have the expression of rhythmic variations of turgidity initiated by stimulus.

Among ordinary responses—that is to say, single response to single stimulus—we have observed three types, depending on the excitability of the tissue. When the excitability remains uniform, the responses are uniform. When the excitability undergoes a gradual diminution, there is a corresponding depression of response—that is to say, fatigue supervenes. And when the excitability increases by degrees, there is a correspondent enhancement of response known as the 'staircase' effect. In addition to these, I have, as explained before, also noticed some curious instances in which the excitability of the tissue appeared to undergo periodic fluctuations, in consequence of which successive responses to

uniform stimuli exhibited periodic fluctuations (p. 106). We may thus have an alternate, periodic, or cyclic fluctuation of excitability exhibited in the responses. In the first of these, the responses are alternately large and small. In the last, we may have either an ascending or descending series, which is periodically repeated.

Cyclic variation in multiple response.—In multiple responses also we find all these types. And if the seat of origin of the multiple excitation be at a distance from the responding leaflet, we have in this fact an added element of variation. For we have now to consider, not simply the periodic variations of excitability of the motile organ, but also those of the excitability of the intervening tissue, causing periodic changes of conductivity. Hence, in records obtained of multiple responses, where the seat of excitation is at a distance, we have a complex combination of variations of amplitude and of period in the pulsations.

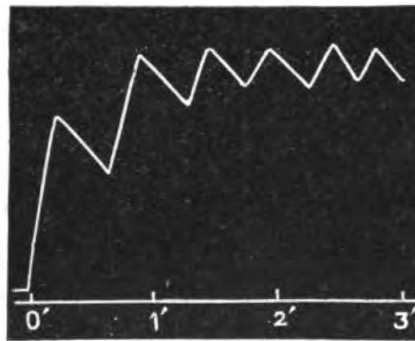

FIG. 117. Multiple Response in *Biophytum*
The rhythm, at first slow, becomes quicker.

Confining our attention to the period alone, we find that multiple responses may be classified under three headings:

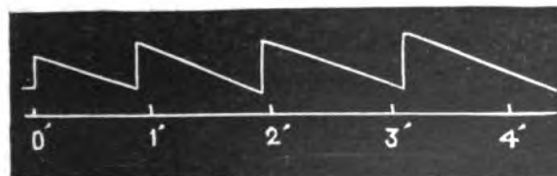

FIG. 118. Multiple Response in *Biophytum*
Quick rhythm becoming slow.

those in which the successive periods are fairly uniform (fig. 116); those in which the pulsations are at first slow and later become quicker (fig. 117); and those which begin with

rapid pulsations, and afterwards slow down (fig. 118). And finally we may have any combination of these (figs. 119 and 120).

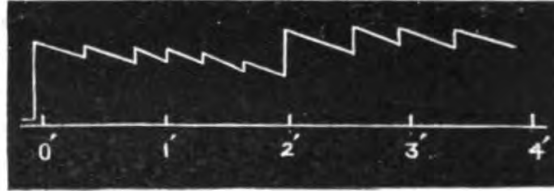

FIG. 119. Multiple Response in *Biophytum*, showing Cyclic Groupings of Amplitude and Period

These cyclic changes of amplitude and period are seen in all types of rhythmic multiple responses, of which I shall show that the autonomous responses of *Desmodium* and the growth-responses of all plants are only special cases. These

characteristics are seen not only in the rhythmic responses of vegetable, but also in those of animal, tissues. The cause of the latter is still regarded as very obscure. Hence the study of similar phenomena in plants, under simpler conditions, may be expected to throw much light on the subject.

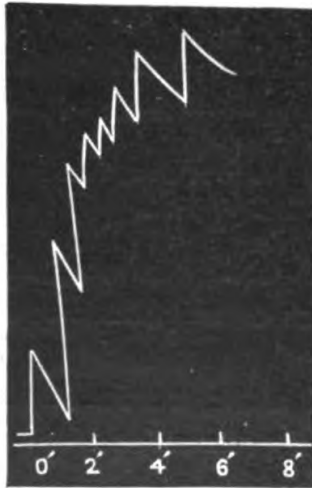

FIG. 120. Multiple Response in *Biophytum*, showing Cyclic Groupings

How striking, even in their more intricate details, are the similarities between multiple responses in plant and animal, will be shown in the next three chapters. For the present I shall confine myself to the consideration of two of the most obscure instances in animal tissues, and

shall show them to be paralleled in the case of the vegetable.

Recurrent visual impulses.—It is known that when we look for some time at a strongly illuminated object and afterwards close the eyes, we see the same image repeating itself many times in succession; and of this phenomenon, so far

as I am aware, no satisfactory explanation has hitherto been offered. The phenomena which have been described in the case of vegetable tissues show, however, that this is nothing but an instance of multiple excitations in the retina caused by strong stimulation. In the case of the plant these recurrent excitations express themselves mechanically as twitches ; in the case of the firefly as flashes of light ; and in the retina as recurrent visual images. In these recurrent visual impulses are found all the peculiarities which I have observed in recurring excitatory impulses in *Biophytum*. This is shown, not only in simple cases, but also in the most complicated. I shall presently give, in illustration of this, two parallel instances of multiple excitation in *Biophytum* and multiple excitation in retina (see table, p. 288), in which the successive intervals undergo similar cyclic changes.

In order to measure accurately the intervals between successive visual images, I use a special stereoscope, based on my discovery of the phenomenon of binocular alternation of vision, and by this means I have found that the after-effects of light in the two eyes are not simultaneous but alternate—that is to say, when the after-image in one eye is most vivid, that in the other eye has just vanished, and *vice versa*. For accurate measurement of this periodicity, it is necessary to have the effect on one eye distinguished from that on the other. For this purpose I have been accustomed to use a stereoscope containing, instead of photographs, incised plates with two inclined cuts, the right eye seeing the slit inclined to the right, and the left eye that inclined to the left. When the observer looks through this stereoscope turned towards a bright sky, his two eyes are acted on by strong stimulus of light. On closing the eyes, periodic visual impulses are sent from the strongly stimulated retina just as the stimulated area of *Biophytum* was found to send out periodic impulses.¹

¹ Bose, 'Binocular Alternation of Vision,' *Response in the Living and Non-Living*, p. 175.

TABLE SHOWING CYCLIC VARIATION OF MULTIPLE RESPONSES
IN BIOPHYTUM AND IN RETINA

Cyclic variation in the periodicity of the multiple response of <i>Biophytum</i>				Cyclic variation in the recurrent visual impulses			
Interval between 1st & 2nd responses	52"	Interval between 1st & 2nd responses	7"				
„ „ 2nd „ 3rd	37"	„ „ 2nd „ 3rd	5'25"				
„ „ 3rd „ 4th	25"	„ „ 3rd „ 4th	6'5"				
„ „ 4th „ 5th	22"	„ „ 4th „ 5th	7"				
„ „ 5th „ 6th	30"	„ „ 5th „ 6th	9"				
„ „ 6th „ 7th	52"	„ „ 6th „ 7th	11"				

In both these cases, therefore, we begin with a comparatively long interval, which grows shorter, and then, again, is progressively lengthened.

Intermittent pulsation.—We have now dealt with one of the two instances of correspondence between obscure pulsatory phenomena in animal and vegetable. The second, which remains to be considered, is that known to physicians as 'the

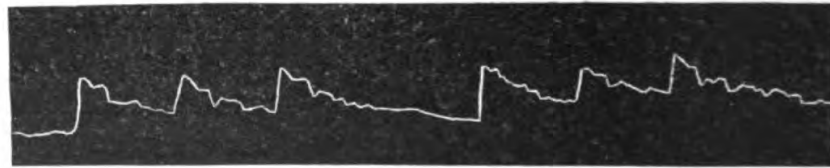

FIG. 121. Intermittent Human Pulse (Broadbent)

intermittent pulse' (fig. 121). 'The term "intermittent" is employed to designate the pulse when a beat is occasionally missing from time to time, while the pulse in the intervals is perfectly regular. It is a remarkable variety of pulse, and is perhaps the least capable of explanation of any. The intermission may happen at regular and definite periods, every four, six, or up to twenty beats; or the number of intervening pulsations may vary. The intermittent pulse may be habitual and constant, and in this case is more likely to be at definite intervals, or it may be occasional only, under the influence of some disturbing cause. . . . Occasionally nervousness and fatigue will render the intermissions more frequent.'¹

¹ Broadbent, *The Pulse*, p. 125.

In connection with this, I have observed, among the types of cyclic variation in multiple response in plants, an instance in which every third response was missing, the period of each second beat being thus approximately twice as long as that of the first. It was easy to see that this was an instance of alternating fatigue, causing the particular record-

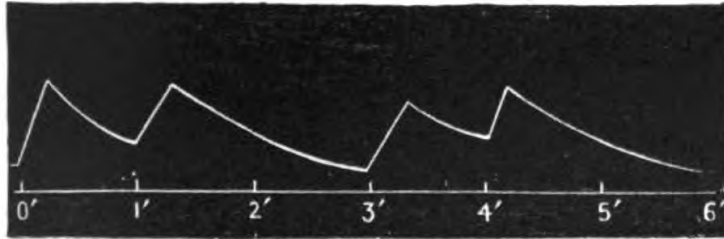

FIG. 122. Intermittence in Pulsation of *Biophytum*

ing leaflet to just miss the response every third time (p. 122). That the excitatory wave arrived in regular sequence, was seen by the fact that the neighbouring leaflets pulsated at regular intervals.

Semi-automatism.—The plant *Biophytum* growing in the open, under favourable conditions of heat and light, sometimes becomes so excessively sensitive that motile impulses are generated, the stimulus causing which it is often difficult to localise. A particular leaflet may have been moved by a puff of wind ; or the alighting of a small insect, or the accidental grazing of an adjacent blade of grass, may have been the original source of the impulse. But this is enough to set all the leaflets of the plant quivering in an extraordinarily lively manner. For from the excited leaflet, the impulse travels inwards, the leaflets falling in centripetal succession. The excitatory wave then reaches the stem and overflows to the other leaves. But this time the progressive closure of the leaflets proceeds in a centrifugal or outward direction. Before the first discharge, however, going through the numerous avenues, can exhaust itself, the second impulse of the multiple response may begin ; and in this way the leaflets exhibit most lively movements without any immediate

U

antecedent cause. In some of these cases the origin of the impulse can be traced, but there are others in which no external source of stimulus can be assigned. And here we find ourselves passing imperceptibly into the obscure region of automatism.

There is much resemblance between such semi-automatic phenomena in *Biophytum* and the well-known instance of spontaneous movements exhibited by *Desmodium gyrans*, the successive mechanical responses of which exhibit all the peculiarities of multiple response as seen in *Biophytum*. In *Desmodium* as in *Biophytum* we have similar cyclic changes of period and of amplitude. Just as in the case of *Biophytum*, when we cannot determine the source of stimulus, we are tempted to regard the phenomenon as automatic, so in the case of *Desmodium gyrans* it is our own inability to trace out the origin of stimulus that leads us to regard the periodic movements of the plant as automatic.

Biophytum, then, under ordinary circumstances, exhibits a single response to a single stimulus ; but when the stimulus is strong, a single stimulation will produce multiple responses, and these will persist long after the cessation of the primary stimulus. Under exceptionally favourable circumstances periodic movements occur, apparently without any exciting cause. I have again found, as will be described more fully in Chapter XXIV., that *Biophytum* itself under favourable circumstances of light and warmth exhibits persistent and long-continued autonomous pulsations, which are in no way distinguishable from those of *Desmodium*. Even the periods of vibration are, generally speaking, similar, inasmuch as in both these plants, under different circumstances, I have recorded pulsations, the periodicities of which vary from one minute or less to four or five minutes. Thus *Biophytum* forms a connecting link between those plants which exhibit only ordinary response (single stimulus, single response) and those in which mechanical movements appear to be automatic. *Biophytum* is also particularly interesting, because in its case we find the same plant, under different

circumstances, behaving in either of these ways; that is to say, giving ordinary response, or exhibiting automatic movements.

Continuity of multiple and automatic response.—If there be thus no real breach of continuity between multiply and automatically responding plants, it should be possible, under suitable circumstances, to obtain from such a characteristically automatic plant as *Desmodium* all those peculiarities of responsive indication which were found in *Biophytum*. The latter, it will be remembered, under the condition of over-excitability, consequent on the absorption of abundance of energy of heat and light, became converted from an ordinarily responding into an automatically responding plant. Conversely we might expect *Desmodium*, under the opposite circumstances, to pass from the condition of giving automatic to that of giving ordinary response.

This inference I have been able to verify, for I succeeded in obtaining the requisite conditions for converting the automatically responding *Desmodium* into an ordinarily responding plant, in three different ways: firstly, by artificially reducing the absorbed energy of the plant, under cautious cooling, care being taken that this did not produce permanent cold-rigor; secondly, by keeping a plant for some days in a dark room, at uniform temperature; and thirdly, by selecting a plant for experiment in the most unfavourable season of the year—that is to say, in the winter, when it was already exhausted by flowering. It will be seen that the principle adopted in each of these cases consisted in depriving the plant of its excess of energy. The third method was the most satisfactory of all, since the leaflets were in a state of natural standstill. In every instance, the automatic movements of the leaflets came to a stop, and the motile organ was reduced, as will be shown, to the ordinarily responding condition. In choosing the leaflets for experiment, it must be remembered that their sensitiveness is liable to disappear with age. In *Biophytum*, for example, very old leaflets show no response. In experimenting, therefore, on leaflets of *Desmodium* which have been

U 2

brought to a state of standstill, care should be taken to select those which have not permanently lost their motility, but in which automatic movements have simply come to a stop for want of a sufficient reserve of latent energy.

Polar excitation of *Desmodium* leaflet in a state of standstill.—We have seen how the leaflets of *Biophytum* showed kathodic excitation at make. I shall now show that a *Desmodium* leaflet, which has been brought to a state of standstill, either naturally or artificially, will exhibit similar effects of polar excitation ; and first, I shall take a case in which arrest was produced by cautious application of cold. I placed one electrode on the petiolule of the leaflet, and the other on the main petiole of the leaf, and applied the stimulus of condenser discharge, the petiole being made kathode. In this way I obtained from the *Desmodium* leaflet a series of single responses to single moderate stimuli.

I next selected specimens which, in the winter season, had come to a state of natural standstill, and tried on them the polar effects of a constant current. Electrical connections were now made at the bases of the petiolules of lateral leaflets in two neighbouring leaves. In completing the electrical circuit, one of these leaflets would be under anodic, and the other under kathodic, action. I found that a considerable electromotive force was necessary to initiate the excitatory reaction. Thus, using thirty volts, I found that the kathodic leaflet responded at make, and the anodic at break. This shows that, as regards polar effects, *Desmodium* in a state of standstill gives exactly the same responses as does *Biophytum*.

In the case of *Biophytum*, moreover, we found that with high E.M.F., we arrived at a phase of response, the A stage, in which both the anode and the kathode caused excitation at make ; and in *Desmodium* in a state of standstill I obtained an exactly similar result, for, on now using a higher E.M.F. of forty-eight volts, with the same specimens as in the last experiment, I obtained excitation at make, at both anode and kathode.

Multiple response caused by strong stimulation in *Desmodium*.—I next tried to find out whether *Desmodium* in a state of standstill would give multiple responses to a strong chemical stimulation, as I had found *Biophytum* to do. Remembering how successive twitches are produced in a frog's muscle, in a nerve-muscle preparation, when the nerve is touched with salt, I applied a strong solution of the same reagent to the petiolule of the arrested *Desmodium* leaflet. This gave rise to a series of four vigorous mechanical pulsations.

In order again to show that multiple response could be initiated by strong thermal stimulus, in *Desmodium* as in *Biophytum*, I selected a plant whose leaflets were in a state of natural standstill. A fairly strong stimulus was applied by means of the thermal stimulator, at a point on the petiole half a centimetre above the insertion of the motile leaflet, in precisely the same manner as was ordinarily done with *Biophytum*. The *Desmodium* leaflet now gave a multiple series of responses, exactly similar to those obtained from *Biophytum*. The first occurred three and a half minutes after the application of stimulus. The successive rise and fall were then uninterrupted. The average period of each response in the series was approximately 4.5 minutes. The multiple responses gradually declined in amplitude, and came to a stop after the thirteenth oscillation. It is thus seen that a strong stimulus will give rise to a multiple series of responses in the case of *Desmodium*, precisely as in that of *Biophytum*.

It is now clear that there is no rigid line of demarcation between multiple and automatic responses. An ordinarily responding plant like *Biophytum*, which gives a single response to single moderate stimulus, and multiple response to strong stimulus, will, under very favourable circumstances, that is to say, when it has absorbed an excess of energy from without, become automatically responding; and, conversely, the pronouncedly automatic *Desmodium* will, under unfavourable circumstances, that is to say, when the sum total of its latent

energy has fallen below par, be reduced to the condition of an ordinarily responding plant, giving single response to single moderate stimulus, and multiple response to strong stimulus.

SUMMARY

On application of a strong stimulus, of whatever nature, to a vegetable tissue, a multiple series of electromotive responses is produced. These multiple responses may also be observed by the electrotactile method.

These multiple excitations, in consequence of a single strong stimulus, may be observed in *Biophytum* as multiple mechanical responses.

These multiple responses may be uniform in character, or may exhibit cyclic variations, similar to those observed in the rhythmic pulsations of animal tissues.

As, in the case of a plant-tissue, a strong stimulus causes multiple excitations, so, in the retina, strong stimulus of light causes multiple visual excitations, seen in recurrent after-images, which have the same characteristics as the multiple after-effects of stimulation in *Biophytum*.

There is no strict line of demarcation between the phenomena of multiple and of automatic response. Under very favourable circumstances—that is to say, when it has absorbed an excess of energy from without—an ordinarily responding plant like *Biophytum* will become converted into an apparently automatically responding plant, like *Desmodium*.

Conversely, under unfavourable circumstances—that is to say, when the sum total of its energy is below par—an automatically responding plant like *Desmodium*, will become converted into an ordinarily responding plant like *Biophytum*. Its leaflets then come to a state of standstill.

Desmodium leaflets in a state of standstill respond to stimulus in exactly the same way as do those of *Biophytum*. To moderate stimulus, both give single response; the polar effects of currents in both are the same; and strong stimulation causes a multiple series of responses in both.

CHAPTER XXIV

AN INQUIRY INTO THE CAUSES OF AUTONOMOUS MOVEMENTS

Production of pulsatory movements as after-effect of energy absorbed—Physical analogue—Localisation of seat of automatic excitation in *Desmodium*—Demonstration of multiple response to a constant stimulus : (1) Chemical—(2) Electrical—(3) Stimulus of light—Multiple response to constant stimulus of light, in : (a) retina—(b) *Biophytum*—(c) *Desmodium*—(4) Thermal—Induction of automatism in *Biophytum* at favourable temperature—(5) Of internal hydrostatic pressure—Absorption of external energy and its absorption by the plant in latent form—True meaning of 'tonic' condition—Cause of rhythmicity—After-effect, and its relative persistence.

IN living tissues, both animal and vegetable, we find numerous cases of spontaneous periodic movements, to which no direct exciting cause is apparently assignable. We confess our inability to trace out the exciting cause by classing such phenomena as *automatic*. Among well-known examples of automatic movements in animal tissues may be cited the pulsatory action of the heart. In the vegetable kingdom, also, such movements are very numerous, and are of various degrees of rapidity, from quick pulsations of some few seconds in duration, to others which occupy periods of several hours. It is to be remembered that these spontaneous movements take place in plants under favourable circumstances, *i.e.* under that totality of the optimum degrees of light, temperature, turgidity, and so on, which is vaguely referred to in vegetable physiology as the *tonic condition*. I intend to set forth presently experimental considerations which will, I hope, serve to make clear the precise significance of this term.

As already said, to call such movements automatic is

only one way of evading the difficulty of finding out their actual cause. When we see these responsive indications given by a moving leaf or leaflet, we can but feel it necessary to trace them to the impulses, internal or external, by which they must have been occasioned. How are such periodic impulses caused, and where is their seat? The investigations which follow are intended to throw light on this, one of the most obscure problems in Physiology. In previous chapters I have demonstrated the fact that the antecedent cause of a periodic effect need not itself be periodic. A stimulus may remain long latent in a tissue, and this latent stimulus may subsequently give rise to periodic excitations.

Such periodic expression of the absorbed energy is not without analogy in the world of physics. For example, we take a glass tube of moderate diameter and push into it, to a certain distance from the free end, a piece of wire gauze, which is then heated over a Bunsen burner. On removal of the heating flame, we observe the after-effect of this absorbed thermal energy, in pulsating movements of the air-column, which give rise to a musical note, whose pitch is determined by their periodicity. We have here a physical analogue to a case previously described, in which the thermal energy absorbed by a tissue of *Biophytum* was afterwards manifested in long-continued periodic movements of the leaflets. In the experiment with the glass tube, the periodicity of aerial pulsation is determined by the size, shape, and temperature of the pulsating column. Similarly, the periodicity of multiple response in the *Biophytum* leaflet is determined by the various constants of the cell-complex which is the seat of the movement.

We saw in *Biophytum* that the region to which strong external stimulus was applied, became the place in which it was accumulated, and the source of subsequent excitation. We further saw that there is no rigid line of demarcation between plants which exhibit multiple responses and those which show autonomous movements, the same plant passing from one category to the other, according to circumstances.

Thus *Biophytum*, which normally speaking gives ordinary single or multiple response, may under favourable circumstances exhibit automatic response. On the other hand, *Desmodium*, which normally speaking exhibits automatic response, will under unfavourable circumstances become converted into an ordinarily responding plant.

As already stated, in the case of *Biophytum*, the point of application of stimulus becomes also the source of subsequent multiple excitations. An observer, unacquainted with the position of this point, might succeed in determining it, by watching the order of pulsation of the leaflets. For if we suppose the stimulus to have been applied at some point in the middle of the leaf, the observer will in that case notice periodic waves of excitation proceeding in opposite directions, and giving rise to the closure of successive leaflets from a common point outwards, thus clearly indicating the position of the point from which successive excitations are initiated. Had the stem, on the other hand, been stimulated, and thus become the source of excitation, these successive impulses would have begun by arriving at the first pair of leaflets, and thence would have passed through all the leaflets to the tip of the leaf, in a centrifugal order. Again, had the stimulus remained latent at the tip of a particular leaf, the successive excitatory waves would then have proceeded through the leaf in a centripetal order, and on reaching the stem would have radiated outwards, or in a centrifugal sequence once more, throughout the other leaves. There are other ways also, presently to be described, by whose means we can obtain an idea of the direction in which the excitatory wave is travelling.

Localisation of seat of origin of autonomous excitation in *Desmodium*.—Our next inquiry is into the very obscure question of the point of origin of the so-called autonomous excitation of *Desmodium*. I have already shown that, if the plant absorbs a certain amount of energy in excess of that required for immediate response, the surplus is stored up, to be given out subsequently in the form of pulsating waves of

excitatory disturbance. But the difficulty is to determine the point at which the latent energy is stored up, and from which the excitatory disturbances subsequently proceed. As we are accustomed to think that stimulus must be due to some sudden *variation*, one is tempted to suppose, as the simplest explanation, that in the case of autonomous movements the stimulation is caused by variations in the rate of absorption of food material, which is probably being carried on, in an intermittent manner only, by the roots and leaves. In this case, if the stimulus proceed from the root, we may expect the excitation to travel to the motile leaflets through the stem, outwards, or in a centrifugal direction. If the assimilating leaves, however, be the source of excitation, we shall look to see the wave of excitation proceeding from without inwards, or centripetally.

In order, therefore, to localise the source of stimulation in *Desmodium gyrans*, for example, I first tried to find out in which direction the excitatory impulse proceeded. Unfortunately in this case, the leaf being provided with only a single pair of motile leaflets, it is impossible to obtain the indication of direction which is given by *Biophytum*, by the successive closure of leaflets in a definite order. I was therefore obliged to have recourse to other expedients.

I have already shown how the transmission of stimulus can be arrested by local application of ether, or by the anodic block. If the pulsating stimulus, therefore, should be central, that is to say, proceeding from the stem, we should then expect the application of ether, or the anodic block, at the junction of the leaf with the stem, to arrest the movement of the leaflets. If, on the other hand, the source of the stimulation should be peripheral, a block produced in the manner described, at a point between the terminal expanded leaflet and the small motile leaflets, would prevent the response of the latter. In carrying out these experiments, however, I found that no such arrest took place in either case.

The fact that the source of stimulation is not central, is also made evident by the following consideration. Had it

been so, the responding movements would have been synchronous with that of the hypothetical source, and all the leaflets of the plant would in that case have had the same period of vibration. As a matter of fact, however, different leaflets have different periodicities.

That the source of stimulation, again, is neither central nor peripheral, may be shown by applying two tight ligatures, one behind and the other in front of the motile leaflets. The passage of the excitatory impulse, should this be transmitted from either direction, will by this means be completely arrested. On carrying out this experiment, however, the periodic pulsation was not affected.

Again, the leaf may be completely detached from the plant, and the terminal leaflet amputated. But the periodic pulsation still proceeds as before, just like the persistent beat of the isolated heart of a frog.

Thus we find that the isolated motile leaflet continues to manifest an evolution of energy in the form of pulsating movements, which cannot be derived from either of the hypothetical sources, whether central or peripheral. It maintains this activity for a long time, when kept under favourable conditions. It thus becomes clear that in the case of *Desmodium* the power of maintaining rhythmic pulsation is local, and resides in the tissue of the motile leaflets.

This does not exclude the possibility of other periodically moving organs obtaining the pulsating excitatory impulses from a distant point. Such a case may well happen when, the conductivity of the intervening tissue being very great, and the excitability of the motile organ high, stimulation, though enfeebled by transmission through a long tract, yet remains above that critical intensity which would cause effective response.

In the previous chapter, I showed that if *Desmodium* be kept in the dark for a sufficiently long period—but not so long as to produce permanent rigor—or if a specimen be taken in the unfavourable season of the year, its autonomic movements would be found to have come to a stop for the

time. This was because the energy stored up in the tissue had become exhausted. If, then, a single stimulus were given, say, by condenser discharge, a single response would be found to ensue. This showed that in such a case the arrest of the automatic movements was not due to the abolition of motility in the leaflet, but only to exhaustion of the energy stored up, which would have given rise to oscillation. It was also shown that if *Desmodium* in a state of standstill were subjected to a single strong thermal stimulus, it exhibited a multiple series of rhythmic responses.

Multiple response to constant stimulus.—Having observed the production of multiple responses as an after-effect of a single strong stimulus, I shall now proceed to demonstrate the production of similar multiple responses by the action of a constant excitatory condition.

1. *Chemical.*—I have shown that in *Biophytum*, and in *Desmodium* at standstill, rhythmic pulsations are produced by the constant action of a chemical stimulant. Analogous phenomena are also known in animal tissues; in the isolated heart in a state of standstill, rhythmic pulsation can be renewed by chemical stimulation.

2. *Electrical.*—I have often observed that when a strong current is sent through *Averrhoa carambola*, a number of rhythmic pulsations are found to take place. In animal tissues, again, similar rhythmic excitations have been observed, not only in cardiac muscle, whose rhythmicity is so marked a characteristic, but also in skeletal and other muscles.

3. *Stimulus of light: (a) On retina.*—And now before I describe the experimental demonstration of periodic excitation in plants, as caused by constant stimulus of light, I shall refer in detail to certain remarkable periodic effects which I have observed in the retina, under the action of the same stimulus. I showed in the last chapter that strong stimulus of light gives rise in the retina to multiple responses, in the form of recurrent after-images. I shall now prove that during the continuance of constant light, pulsatory visual effects are

produced. These pulsations are not usually noticed in visual sensation, owing firstly to the absence of a standard of comparison, and secondly to the fact that though the impressions on the individual retinae undergo variation, the sum total of the two remains constant. I have been able to provide the necessary comparison-standards by having two distinguishable images produced in the two eyes, the fluctuation in the visual excitation in one eye being thus capable of detection by comparison with that in the other. It would have been impossible to detect this fluctuation had the excitatory variation taken place in the two eyes simultaneously, *i.e.* if the maximum excitation in the one had occurred at the same moment as the maximum excitation in the other. But I have found that, as regards excitation, there is a relative difference of phase, of half a period, between the two eyes, so that the maximum effect at the given moment in one eye corresponds to the minimum in the other. It is owing to this fact that the periodic excitations in each retina are brought out in an unmistakable manner by the following experiment, which consists in looking at two slits through the modified stereoscope described in the previous chapter. One of the two slits inclines to the right and the other to the left, and on looking through these at a bright sky, the right eye perceives a bar of light turned, say to the right, and the left eye a bar turned to the left, the resultant impression being that of an inclined cross.

When the stereoscope is turned to a bright sky, and the cross looked at steadily for some time, it will be found, owing to pulsatory excitation in each eye, that when one arm of the cross begins to be dim, the other becomes bright, and *vice versa*. These periodic fluctuations are perceived continuously under the constant action of light.¹

I shall now proceed to the demonstration of the very interesting rhythmic movements caused in plants under constant light-stimulus. As we wish to prove that the cause of automatic movements lies in the action of some

¹ The experiment will be found described in detail in my book, *Response in the Living and Non-Living*, p. 175.

continuous stimulation, it is necessary to satisfy ourselves that this continuous source is the sole cause of the rhythmic movements. This will appear conclusive, if it is made clear that the plant does not possess any intrinsic energy of self-movement, but only the power to regulate rhythmically the overflow of energy supplied.

The demonstration will then be made rigorous, if we take a plant which is not manifesting automatic movement, and cause it to exhibit such action by the application of constant external stimulus. For the purpose of this experiment, then, we may take the leaflet of *Desmodium* in a state of standstill, or that of *Biophytum* under normal conditions, which, as we have seen, may be regarded as practically equivalent to *Desmodium* in a standstill condition. If therefore we can succeed in making *Biophytum* exhibit rhythmic movements under the continuous action of a given external energy, we shall not need to look for the explanation of the so-called automatic movements of *Desmodium* to some periodically varying stimulus, any constant stimulus being then proved fully competent to produce the rhythmic pulsations.

(b) *On Biophytum*.—I first subjected the motile leaflet of *Biophytum* to light of comparatively short duration, *i.e.* two minutes, by throwing sunlight upon it from a reflecting mirror. There was no immediate response, but after a latent period of one minute the leaflet gave a single response. I next subjected the plant to the continuous action of light during ten minutes. I obtained rhythmic pulsations, there being two responses in the given time. I then cut off the light, and the rhythmic action was stopped. After an interval of several minutes I again applied light for ten minutes, and this gave rise to similar rhythmic responses. The procedure was repeated once more with the same results. With another specimen, I applied light for a still longer period, *i.e.* twelve minutes, and I obtained three pulsations. It will thus be seen that we have here a regulated outflow of energy; the plant absorbs energy continuously, but gives it out in a pulsating manner (fig. 123). In this way, a number

of autonomic pulsations may be obtained in *Biophytum* under the continuous stimulation of light. The recovery not being complete after each pulse, the result is a progressive folding downwards of the leaflets, and this makes it impossible after a time to observe further responses. I shall presently describe, however, another method of supplying the plant with energy, by thermal means, in which case the autonomous pulsation in *Biophytum* is prolonged indefinitely.

(c) *On Desmodium leaflet at standstill.*—Turning now to the leaflet of *Desmodium* in a state of standstill, I find that application of sunlight initiates rhythmic movements. In a particular experiment, light was continuously applied for half an hour, and there were produced in that time seven vibrations. The responses were found to undergo 'staircase' increase by increasing absorption of energy, and the resultant increase of molecular mobility produced in the tissue. On the stoppage of light the rhythmic pulsations persisted for some time, the amplitude, however, undergoing diminution owing to the run-down of absorbed energy.

4. *Thermal: (a) Induction of autonomous response in Biophytum.*—I shall now describe an experiment of very great theoretical importance, by which I have been able to convert a specimen of *Biophytum* from an ordinary into an automatically responding plant. Guided by the theoretical inference which I have already stated, that it is an excess of energy that brings about the condition of automatism, I subjected a specimen of *Biophytum* to the constant stimulus of a moderately high temperature. I first placed the specimen in a chamber whose temperature was 37° C., and it was astonishing to see the younger (and therefore more excitable)

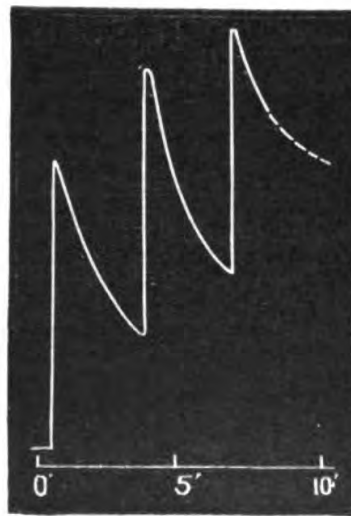

FIG. 123. Multiple Response of *Biophytum* under the Continuous Action of Light

leaflets, at first quiescent, break into a sustained series of uninterrupted pulsatory movements, which they kept up throughout the maintenance of the condition of high temperature. It was interesting also to observe the quickening of vibration by absorption of energy. The pulses were at first slow, each having a period of four minutes, but they became steadily more rapid, till they had reached a frequency of .20 vibrations in a minute. A continuous record of these periods was made during one hour, and the following tabular statement exhibits the results :

TABLE SHOWING PERIODS OF SUCCESSIVE PULSATIONS IN BIOPHYTUM WHEN TEMPERATURE IS RAISED TO 37° C.

No. of pulse	Period	No. of pulse	Period	No. of pulse	Period
1	4 minutes	11	2.5 minutes	21	.5 minute
2	4 "	12	2.5 "	22	.5 "
3	4 "	13	2.5 "	23	.5 "
4	4 "	14	2.5 "	24	.5 "
5	4 "	15	2 "	25	.5 "
6	3 "	16	1.5 minute	26	.5 "
7	3 "	17	1.5 "	27	.5 "
8	3 "	18	1 "	28	.5 "
9	3 "	19	1 "	29	.5 "
10	2.5 "	20	.5 "	30	.5 "

Having thus found that a high temperature was favourable to the initiation of automatic movements in *Biophytum*, I was next desirous of determining the minimum temperature at which such responses could be induced. For this purpose I took a fresh specimen of *Biophytum*, and cautiously raised the temperature of the chamber from 23° C. upwards. When 29° C. had been reached, I obtained the first pulse of autonomous response, the period being rather slow—that is to say, 8.5 minutes—and by the time the temperature had gone up to 35° C. this period had become shortened to two minutes. We find here a phenomenon identical with that of *Desmodium*, where the frequency of vibration is found to be increased with rising temperature.

In *Desmodium*, the autonomous movement is initiated at a certain more or less definite temperature, which is about 17° C. This we may call the critical thermo-tonic condition. Below this critical degree, *Desmodium* ceases to be autonomic, and becomes an ordinarily responding plant. In *Biophytum*, similarly, the critical thermo-tonic point is about 29° C. Above this, the young leaflets are autonomic, and below it, ordinarily responding. The difference between *Desmodium* and *Biophytum* in this respect lies, therefore, in the fact that their critical thermo-tonic points are about twelve degrees apart.

In the case of *Biophytum*, when the temperature is maintained at a uniform favourable degree, the periods of the

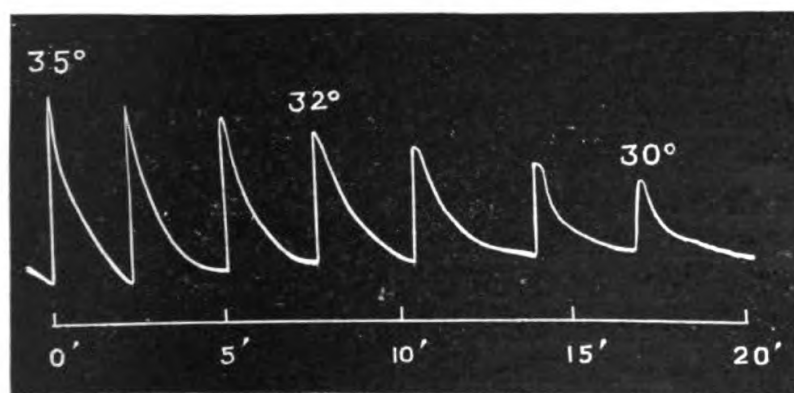

FIG. 124. Induction of Autonomous Response in *Biophytum*, at Moderately High Temperature of 35° C.

Note the diminution of amplitude of response with the gradual loss of latent energy, consequent on falling temperature. The pulsations came to a stop below 29° C.

autonomous pulsations become very regular. It has been said that these pulsatory movements are maintained by means of energy absorbed, and with *Biophytum* I found an added opportunity of demonstrating this fact. A particular plant had been kept at a uniform temperature of 35° C., under which the young leaflets gave autonomous responses. The heating current, by which this temperature was maintained uniform, was now stopped, and the chamber gradually

X

cooled down. One of the young leaflets had been attached to the Optical Lever, and records were now taken continuously. It was very interesting to observe how, with the gradual loss of absorbed energy, the pulsating movements of the plant became diminished in amplitude (fig. 124) till they came to a stop. We shall find exactly the same thing in the case of *Desmodium*.

I referred in the last chapter to certain observations of my own, in which the leaflets of *Biophytum* were found, under favourable circumstances of light and temperature, to give rise to apparently spontaneous movements, which could not be traced to any definite *varying* external cause. From the experiment just described, however, we see that it was the *continuous* stimulus of favourable temperature and light combined that caused this rhythmic movement, which appeared as automatic.

(b) **Resumption of automatic movements in *Desmodium*.**—Similarly in *Desmodium*, if the isolated leaflet in which all movement has been brought to a stop, but not to a condition of permanent rigor, be raised in temperature, and if the tissue be maintained uniformly at this higher point, the pulsatory movement will be found to commence and persist for a long time. The initiation and maintenance of the responses here, again, is undoubtedly due to the renewed supply of energy.

A new difficulty now arises, however, from our habit of regarding stimulation as dependent upon some *sudden variation* of external conditions. For we are here confronted with a case in which uniform and continuous application of heat produces stimulation. It may be urged that there has been some variation of environmental conditions, in the fact of the rise of temperature before the constant point was reached. But it has to be remembered, that this rise was purposely made very gradual, and even if a single stimulation had been caused by this preliminary thermal variation, it would have evoked only a single response, or at most a few multiple responses. But how are we to account for these

long-continued periodic pulsations, which are kept up during the whole time in which the leaflets are maintained at an *unvarying* given temperature?

We are thus led to see that stimulation is not in all cases dependent upon the occurrence of a sudden change in the exciting cause. On the contrary, excitation may be produced, as we have seen, under a constant and uniform exciting condition. If we analyse the multiple responses produced in *Biophytum* as the after-effect of the application of a strong thermal stimulus, we find, as said before, that some part of this thermal energy remains latent, and afterwards gives rise to recurring pulsations.

5. *Of internal hydrostatic pressure.*—The isolated animal heart, when in a state of standstill, is found to renew its excitatory pulsation under an increase of internal hydrostatic pressure. I shall show later (p. 349) that a *Desmodium* leaflet, similarly, when in a state of standstill, can be made to resume its excitatory rhythmic activity, by increasing the internal hydrostatic pressure.

The true meaning of 'tonic' condition.—We have thus seen that under the continuous action of a constant source of external stimulus, multiple responses are produced. We have also seen that the excess of energy absorbed remains latent in the tissue, in consequence of which, even on the cessation of external stimulation, the pulsatory movements are maintained for a longer or shorter time. It is thus the excess of stimulus absorbed which renders the tissue excitable, or 'tonic.' Hence we may have tonicity imparted by light, *photo-tonus*; by favourable temperature, *thermo-tonus*; by electric current, *electro-tonus*; by internal hydrostatic pressure, *hydro-tonus*; or by the presence of favourable chemical substances, *chemo-tonus*. We have seen that each one of these, by itself, was competent to give rise to multiple responses. It has been shown further that there is no hard-and-fast line between such multiple and automatic responses, the one passing imperceptibly into the other.

We have now seen that the tonic condition of the plant is

X 2

determined by the sum total of the latent energy derived from all the above-named factors. This internal factor, of latent energy, will be shown to play a very important part in all response-phenomena, and as it thus becomes necessary to have some convenient means of referring to it, we shall henceforth designate it as the **Internal Energy** of the plant.

Automatic movements in plants are thus only exhibited under favourable tonic conditions. It has been shown that the plant displays rhythmic activity when subjected to different forms of constant stimulus, and we have now investigated separately the effects of such constant stimuli—chemical, electrical, thermal, photic, and hydrostatic. As has been explained before, if a given stimulus be not of sufficient intensity to evoke visible response, yet the absorbed energy may render the tissue capable of responding to another subsequent stimulus, which by itself would have been ineffectual; in other words, the tissue is made excitable by the presence of a stimulus which has not of itself been adequate to cause response. When this latent excitability exceeds a certain amount, any further increase may be expressed in a visible manner by mechanical pulsation. Now, taking the various forms of stimulus to which the plant is constantly exposed—namely, warmth, light, moisture, and the action of the various chemical reagents, organic and inorganic, present in it or absorbed by it—it is clear that each of these exerts its stimulating effect independently; any one by itself may then make the tissue excitable to the verge of response; in this condition, though there is no outward sign of the fact, there is a considerable amount of latent energy; and the incidence of any second and additional form of stimulation is now sufficient to precipitate the excitation in visible form. These considerations will show how, by the cumulative and additive effects of all the forms of constant stimulation mentioned above, the plant may become so highly excitable as to manifest the fact by giving rise to responses which appear as automatic. The tonic condition is thus the latent excitatory

condition, which is determined by the sum total of all these exciting factors.

In connection with these facts, it is well to bear in mind that the excitability imparted by a stimulus does not always increase continuously with the intensity. On the contrary, there may be an optimum intensity beyond which excitability may be diminished.

We have now seen that the energy which expresses itself in pulsatory movements may be derived by the plant, either directly from immediate external sources ; or from the excess of such energy, already accumulated and held latent in the tissue, aided by the incidence of external stimulation ; or from an excessive accumulation of such latent energy alone. In the last case, however, if the plant were kept isolated from all external supply of energy, it is clear that its reserve would become exhausted, and its automatic movements would cease. I have already described an experiment in which this arrest of pulsation took place in the case of a specimen of *Desmodium* kept in a dark room. We then saw that revival of response was only brought about when fresh stimulus was applied. And we have also seen the converse, namely, the ordinarily responding *Biophytum*, when supplied with excess of energy, become automatically responding.

Cause of rhythmicity.—Having, then, seen that it is a constant source of energy, external or internal—the latter being really derived from a previous absorption of external stimulus—which maintains the so-called automatic movements in plants, we have still to determine how it is that a latent or constantly acting external stimulus can find only periodic expression? In connection with this we have seen how, when the minimal factor of stimulating intensity is exceeded, there is a manifestation of the fact by visible response. I have also shown (p. 245) that after each excitatory discharge there is a marked diminution of both conductivity and excitability ; and a new stimulus, or existing excess of stimulus, owing to the loss of these properties, is retarded for a time from producing any effect on the motile tissue. It

is only after the lapse of an interval that the protoplasm regains its original properties. There is thus an oscillatory variation of conductivity and excitability. It will therefore be seen how, under the circumstances, a constant stimulus, or a stimulus which is latent in the tissue, can find an excitatory expression only in a pulsating manner. Perhaps a physical model will enable us to visualise this process. Imagine a reservoir into which flows a constant supply of water. An elastic conducting pipe is led from the reservoir, and this pipe is constricted by a compressing spring. On the far open end of this pipe abuts the flattened end of an indicating lever. When water has been supplied for some time, its level is gradually raised, producing an increasing pressure. At a certain point, when the pressure becomes sufficiently great, the spring which keeps the elastic tube constricted gives way, and there is an impulsive discharge of water, which, impinging against the lever, gives rise to a visible response. But the yielding spring again closes, the tube is once more constricted, and thus by the oscillation of the spring which regulates the conduction of water, pulsating hydraulic impulses are kept up. On account of the oscillating mechanism, the outflow, and consequent mechanical response, are periodic, though the supply is constant. In this model the first period, before the pressure of water becomes sufficient to force open the spring, corresponds to the latent period in plant response; the oscillation of the flow of water corresponds to the oscillation of conductivity; and the responding lever corresponds to the motile leaflet. Similarly, an ill-fitting spring tap is thus often thrown into a pulsating movement, by the constant pressure of water from the main, and there is then seen a rhythmic play of the water-jet.

‘After-effect’ and its relative persistence.—In the experiment on *Biophytum* under the continued action of light, we saw that for a period of one minute, during which the plant was absorbing light, there was no response. Then after this latent period of one minute, the energy absorbed reached the verge of response. The excitatory discharge was followed by a

retardation of conductivity and excitability, which was, however, gradually recovered, and there were produced a second and then successive periodic responsive movements.

In the hydraulic model, if the capacity of the reservoir be small, the cessation of the water-supply will cause an immediate cessation of the rhythmic movement of the indicating lever. In *Biophytum*, similarly, we found that the periodic response continued as long as energy was supplied, and that the movement soon stopped on the stoppage of the supply of external energy. But if the capacity of the reservoir be great, the accumulation may be sufficient to maintain the oscillation for a considerable length of time, even after the main supply is cut off. And we see that in *Desmodium* the responsive movements continue in a persistent manner, though the immediate source of stimulation be interrupted. A similar difference in the persistence of after-effects, depending on relative capacities for storage of energy, is seen in the two classes of inorganic substances, which are distinguished as fluorescent and phosphorescent. In the first, the responsive emission of light caused by a preceding excitation is extremely short-lived; but in the latter it continues long after the light stimulus has ceased to act. Thus *Desmodium* may continue to exhibit rhythmic movements, though not at the moment exposed to the marked action of any special source of stimulus. But for the display of long-continued rhythmic movements it should previously have absorbed a considerable amount of energy from an external source—in other words, it must have been exposed to those circumstances which produce a favourable tonic condition.

We have thus obtained some insight into that very obscure phenomenon which is known as the after-effect. By the inertia of the organism there is a certain loss of time before response begins to take place, and this determines the latent period. But when the stimulus has already initiated movement, the responding organ will, through the same inertia, continue to show this movement even when the stimulus has ceased to act. There is another factor, however, which

determines the persistence of this after-effect, namely, the larger or smaller capacity of the tissue itself to hold energy latent within it.

In the attempt to investigate the cause of automatic movements in *Desmodium*, there were three points of inquiry which had to be determined. First, there was the question of the seat of excitation; second, that of the nature of the stimulus which maintained the rhythmic pulsation; and third, the determination of the process by which constant stimulus found periodic expression.

I have shown that the seat of excitation in *Desmodium* is neither central nor peripheral, but is in, or in immediate contiguity with, the motile tissue itself, which resembles in this respect the animal heart, the seat of excitation there also being in the cardiac tissue itself (Chapter XXVI.).

I have also shown that as the cause of excitation it is not necessary to have any *sudden variation*. A constant stimulus, of whatever nature, is found efficient to produce excitation.

I have also demonstrated that periodic pulsation is produced in *Desmodium* at standstill, by a constant thermal stimulus; also that periodic pulsations are produced in *Biophytum* and in *Desmodium* by the constant action of a chemical stimulant. I have shown further that rhythmic excitation was produced in *Averrhoa carambola* by the passage of a constant electric current. And, finally, I have shown that, just as in the retina, under constant stimulus of light we have periodic visual excitations, so also in *Biophytum*, under constant stimulus of light we obtain periodic excitations which give rise to rhythmic movements. In the animal tissue, similar multiple rhythmic responses are met with under constant stimulus.

Since we have found it to be a fundamental characteristic of the tissue of a rhythmically-responding plant like *Biophytum* or *Desmodium* to give a response which cannot be increased by any excess in the stimulus-intensity (maximal response or none), we should expect that the excess over the

minimally effective stimulus must remain latent in the tissue. This is evidenced by the fact that on applying a very strong stimulus we obtain, not a single but multiple responses. Thus all the various forms of constant stimulus to which it is exposed—warmth, light, moisture, and the different chemical reagents, organic and inorganic, present in or absorbed by it—become latent, and the sum total of all these stimulating factors determines its 'tonic' condition.

When this accumulated latent energy exceeds a certain value, it is visibly manifested in the form of the so-called 'automatic' movements.

The *periodicity* of the excitatory discharges which give rise to rhythmic movements in a plant that is under constant latent stimulus, is brought about by the peculiarity which has been demonstrated, that after each discharge the conductivity and excitability of the tissue are diminished, and are only gradually regained. This oscillation in the conductivity regulates the outflow of energy, and causes the rhythmicity of the responsive movements.

SUMMARY

In *Desmodium*, the seat of excitation of the lateral leaflets lies in the motile organ itself.

Multiple response is produced in the plant, as in the animal, under constant thermal, chemical, or electrical stimulus.

The retina, under constant stimulus of light, exhibits periodic visual pulsations.

Similarly, the leaflet of *Biophytum*, and that of *Desmodium* at standstill, under continuous stimulation of light, exhibit rhythmic mechanical pulsations.

Biophytum, when raised to a temperature of about 29° C., becomes automatically responding. Under these circumstances, the only difference between the so-called automatism of *Biophytum* and *Desmodium* is that, in the latter case, the critical thermo-tonic condition is arrived at about 12° C. earlier.

The energy which expresses itself in pulsatory movements may be derived by the plant, either directly from immediate external sources, or from the excess of such energy, already accumulated and held latent in the tissue, aided by the incidence of external stimulation, or from an excessive accumulation of such latent energy alone.

By 'tonic' condition is meant the latent excitatory condition of the plant, as determined by the sum total of the stimulating factors which are, or have been, derived from its environment. In other words, the tonic condition depends on the **internal energy** of the plant.

In rhythmic tissues, a constant stimulus, external or internal, finds pulsatory expression in consequence of the oscillatory variation of conductivity and excitability.

The duration of rhythmic movements, in the absence of any external exciting cause, depends on the amount of energy previously absorbed and held latent in the plant. The persistence of this after-effect, therefore, depends also on the greater or less capacity of the tissue for storage of energy. These rhythmic movements thus appear to be automatic, but when the reserve is exhausted, the so-called automatic movements come to a stop. Renewal of pulsatory movements can then take place only on the supply of fresh energy from without.

CHAPTER XXV

INFLUENCE OF VARIOUS CHEMICAL REAGENTS ON THE AUTONOMOUS RESPONSE OF DESMODIUM GYRANS

The recorder and experimental chamber—Absolute measurement of period and amplitude of *Desmodium*-oscillation—Responsive significance of up and down movements deduced from (a) analogy with response of *Mimosa*; (b) test of increased internal hydrostatic pressure—‘Systolic’ contraction and ‘diastolic’ expansion of *Desmodium* pulvinus—Mode of application of chemical reagents—Action of chemical reagents modified by : tonic condition of plants ; strength of solution ; and duration of application—Effect of anæsthetics—Effect of alcohol—Effect of carbonic acid—Effects of ammonia and of carbon disulphide—Effect of copper sulphate solution, either when applied externally, direct on the pulvinus, or internally—Spark-record of *Desmodium*-pulsation.

HAVING thus, in the last chapter, traced the causes of autonomous movements in plants, I shall now, taking *Desmodium gyrans* as the type, describe the effect of various agencies on the so-called ‘spontaneous’ responses of its lateral leaflets.

With regard to the experimental arrangements for making the record, I have already in Chapter I. described how records may be obtained, using the intact plant for experiment. The automatic movements of the leaflets, however, persist, even after the petiole bearing them is detached, the cut end being kept in water. Under proper conditions, the rhythmic pulsations of the detached specimen will continue for a couple of days. In order, therefore, to subject the motile organ to various modifying conditions, it is much more convenient to use such a specimen than the whole plant.

The recorder and experimental chamber.—As the extent of the movement of the tip of the leaflet is considerable, no magnification is necessary for the record. A single cocoon thread is attached to the middle of the leaflet by a

drop of shellac varnish, the other end of the thread being tied to the longer arm of the Optic Lever, which is 30 cm. long. The distance of the recording drum from the mirror is also 30 cm. The length of the lever arm being thus equal to the distance of the drum, and the extent of the angular movement being by reflection doubled, it will be seen that the movement is magnified twice. The thread is attached, however, to the middle of the leaflet, and the record there-

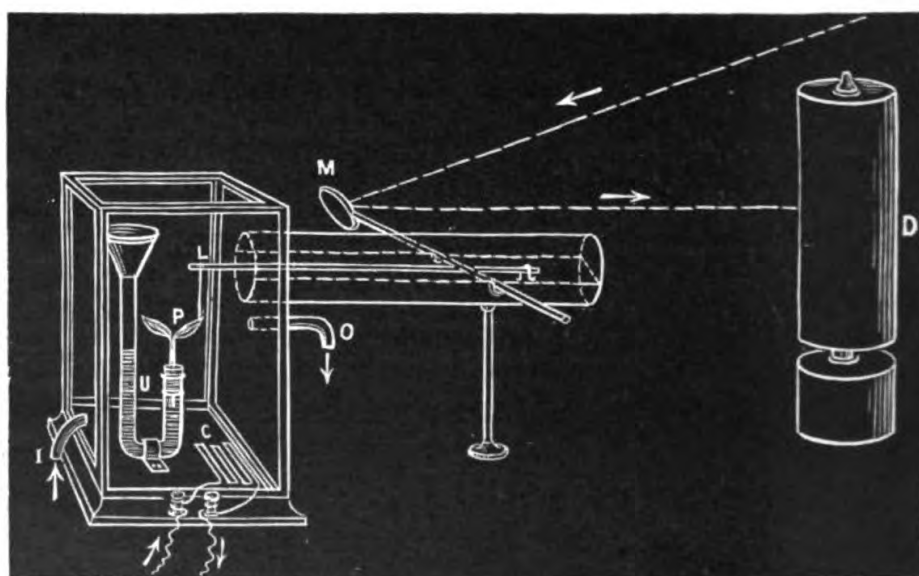

FIG. 125. Experimental Apparatus for Making Records of Pulsation of *Desmodium*

Leaflet, P, mounted in U-tube in plant chamber, and attached to long arm of Optical Lever, L; M, mirror attached to fulcrum-rod; D, recording drum; I, O, inlet and outlet pipes for gases and vapours introduced into plant chamber; C, electric heating coil.

fore gives the movement of the tip unmagnified. The records given in some of the figures are thus without magnification. In others, again, the records are on a reduced scale.

It will be understood here that the extent of movement will vary with the length of the leaflet, some of these being very small, and others relatively large.

In the apparatus shown in fig. 125, the smaller chamber contains the motile leaflets mounted in a tube filled with water. By means of an inlet-pipe, different gases may be

introduced into the chamber for any desired length of time, after which fresh air may be re-introduced. In order to produce variations of temperature there is a coil of wire for electric heating.

The automatic movements of the leaflet, both up and down, take place in some cases as a number of jerks, which may pass gradually into continuous movement. In others they are continuous from the beginning. From the normal or highest position, the leaflet, generally speaking, sinks somewhat rapidly. Having reached its maximum depressed position, there is a pause, after which there is rather a slow return to its original position. The up and down motion is in some cases approximately straight. In other cases, the sub-petiole of the leaflet is slightly twisted after its descent, and the curve described becomes more circular. For the purpose of the present investigation, specimens were selected in which the movement of the leaflet took place gradually, without jerks, the up and down movements being approximately in a straight line.

Absolute measurement of period and amplitude of *Desmodium* - oscillation. — The period of a single oscillation varies with the temperature and the tonic condition of the plant. In winter it may be as long as five, in summer as short as two minutes, and when the temperature is artificially raised, the period may be even further reduced to one minute. As a concrete example, affording a clear idea of the general characteristics of the pulsatory movement of *Desmodium*, I shall give the following results, obtained from a photographic record which gives the extent of the absolute movement (fig. 126).

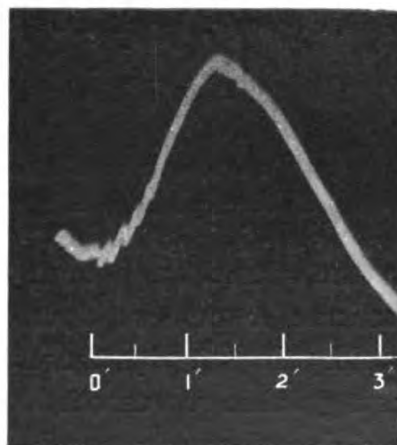

FIG. 126. Photographic Record of Pulsation of *Desmodium*

The up movement of the record means down movement of the leaflet in this and all subsequent records.

The period of the complete vibration was in this case 3.5 minutes, of which the down movement was accomplished in the course of 1.5 minute. The up movement was relatively slower, and was accomplished in two minutes. The mean amplitude of pulsation—that is to say, the vertical distance travelled by the tip of the leaf—was 25 mm. The fact that the down movement is, generally speaking, relatively the quicker is seen visually demonstrated in the photographic record of uniform pulsations obtained

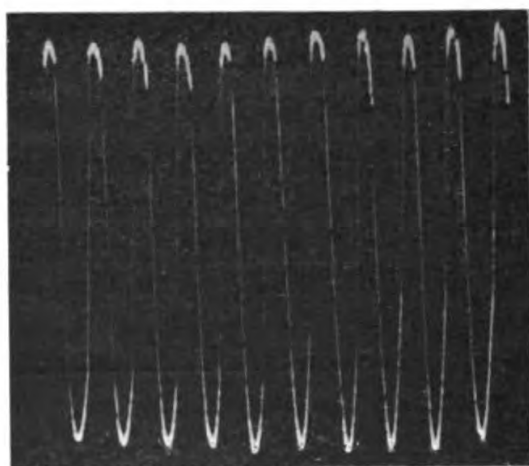

FIG. 127. Photographic Record of Uniform Pulsations in *Desmodium*

Period of each pulsation = 2.7 minutes.

with another specimen (fig. 127). In connection with this, certain peculiarities of photographic action should be borne in mind. It is found that a short exposure gives an image which in the case of a line is very thin and sometimes consists of only the faintest impression; but when the exposure is prolonged the line is much thickened. Hence,

in the records, the faint or more sharply outlined portions indicate responsive down movements which were relatively rapid. In fig. 127, therefore, these differences of line afford us a graphic representation of the various rates of movement, and durations of pause, in the different parts of the curve. In all the photographic records given here and elsewhere, we are thus able to distinguish the down movements by the relative thinness of the recording line. In fig. 134, at the end of this chapter, will be found a spark-record of the pulsation of *Desmodium* in which the different rates of movement at different stages of the response can be distinguished at a glance.

In the multiple responses of *Biophytum*, though, generally

speaking, the down movement is more rapid, yet at times the up and down movements approximate to each other in this respect. I have occasionally found similar instances in the pulsatory movement of *Desmodium*, when there would be only a slight difference between the rates of the up and down movements. The normal rates again may even become reversed under the influence of external agencies.

Responsive significance of up and down movements.—

A question of some difficulty and importance arises here as to the significance, whether of contraction or relaxation, of these up and down movements. We saw in the cases of *Mimosa* and *Biophytum* that the down movement was due to the relatively greater contraction of the lower half of the pulvinus, and the up movement to recovery or relaxation. It must be borne in mind that the upper half of the pulvinus of *Mimosa*, like the lower, is also excitable, though in a minor degree, as will be shown in a subsequent chapter. We have further seen that the more excitable half responds earlier to stimulus. The depression of the leaf, then, is due to the earlier and greater contraction of the lower half of the organ; and its subsequent erection, to a natural expansive recovery, possibly aided by the later and feebler contraction of the upper half of the pulvinus. Arguing from analogy, we may regard the movement of the *Desmodium* leaflet as essentially similar to this. For here too we find, generally speaking, that the down movement is the more energetic, and the up movement relatively the slower, of the two. Hence we may infer that in *Desmodium* the down movement is due to contraction and the up movement to relaxation.

Test by increased internal hydrostatic pressure.—It will be shown on page 349 that when *Desmodium* in a sub-tonic condition undergoes arrest of pulsation, an increase of internal hydrostatic pressure is found to renew the rhythmic activity. With fairly high internal pressure, the frequency of the pulsation is increased, though the amplitude is decreased. In order now to test the responsive significance of the up and down movements respectively, I tried the effect of an increase

of internal hydrostatic pressure in shifting the vibration-limits of the *Desmodium* leaflet.

It will be remembered that in the case of *Mimosa* the effect of this increased internal hydrostatic pressure was to cause the erection of the leaf above its normal position. If, then, the same result should follow in the case of *Desmodium*, we should be justified in inferring that the mechanics of the

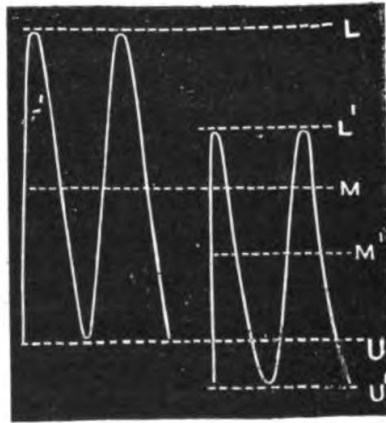

FIG. 128. Displacement of Mean Position of Vibration of *Desmodium* Leaflet by Increased Internal Hydrostatic Pressure

U, upper limit; L, lower limit; M, mean position under normal conditions; U', L', M', corresponding positions under increased internal hydrostatic pressure; M M' is the extent of displacement upwards. Increased internal pressure, generally speaking, produces a movement towards expansion, and tends to diminish the amplitude of the pulse, while increasing the frequency.

motile organ were similar in the two cases. The increase of internal hydrostatic pressure was in this case effected by the same method as was employed in that of *Mimosa*—that is to say, the cut end of the petiole of *Desmodium* was placed in one limb of a U-tube, filled with water, and the pressure was increased by adding water, so as to raise the level at the free end of the tube. As the leaflet of *Desmodium*, however, is in constant oscillation, we must regard the mean of its vibration-limits as the normal mean, and the extent of the leaflet's erection under increase of hydrostatic pressure must be measured by the shifting upwards of this mean.

In carrying out this experiment, I found, on applying the increase of internal pressure exerted by a water-column of 10 cm., that, as will be seen in fig. 128, the lower limit of oscillation was displaced upwards in the record by 11.5 mm. and the upper limit by 3.5 mm. The mean position was thus raised by 7.5 mm. As the magnification of the record was in this particular case five times, it will be seen that the pressure exerted by a height of 10 cm. of

water had thus produced an absolute displacement of the mean position of the leaflet, of 1.5 mm. Considering these facts, it becomes reasonable to regard the motile indications of *Desmodium** as similar to those of *Mimosa*; hence the down position of the *Desmodium* leaflet may be regarded as one of contraction, the up position being one of relaxation. Thus in *Desmodium* the down position of the leaflet corresponds to the systolic contraction, and the up position to the diastolic expansion of the heart.

Mode of application of chemical reagents.—Having now to some extent determined the character of the movements of the *Desmodium*

leaflet, we shall proceed to observe in detail the modification of their movements by the action of various chemical reagents. Three different methods of application may be employed. In the first place, the chemical reagent may be dissolved in the water in which the specimen is placed. The solution will thus reach the motile

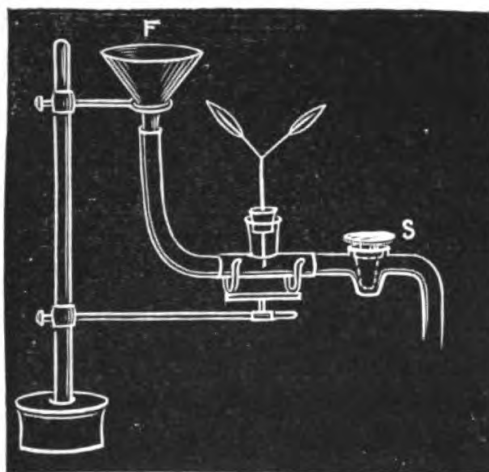

FIG. 129. Method of Application of Chemical Agent to Cut End of Petiole

organ by the same process as that which brings about the ascent of sap. The characteristic action of the chemical reagent will be demonstrated in the subsequent modification of the responses.

This method of applying a reagent at one point—in this instance the cut end of the petiole—and observing the subsequent physiological effect on the distant motile organ, is of special interest and importance in the case of poisons. For it serves to elucidate the obscure question of the ascent of sap through tissues that have been killed by poison (p. 385).

In order to observe and compare the responses of the

Y

given plant, before and after the application of the solution, it is necessary that the continuity of the record should be in no way disturbed. For this purpose I insert the specimen in the arrangement shown in the diagram (fig. 129). One end of the tube is connected with a funnel, F, by means of an india-rubber tubing; the other end is provided with a stop-cock. The tube is first filled with water, and the stop-cock, S, closed. The normal responses of the leaflet are now taken, with the petiole in water. Next, by proper manipulation of the stop-cock, the water is allowed to run out, and its place is taken by the chemical solution which is passed in at the funnel. The record which is now taken exhibits the effect of the drug.

The second of our three methods of experiment is that of direct application—that is to say, touching the motile organ itself with a drop of the solution. In this case, the modification of response takes place rapidly. And, lastly, gaseous substances may be introduced or withdrawn from the plant chamber, by means of suitable inlet and outlet pipes.

Action of chemical reagents modified by : tonic condition of tissue ; strength of solution ; duration of application.—There are certain general considerations of a very significant kind which it will be well to specify at this point. Though the fundamental effect of any given reagent is definite, yet certain minor variations of this effect, due to the constitution of the individual plant, are liable to occur, and these are often extremely suggestive. Two successive experiments, for example, were performed to determine the action of the poison mercuric chloride on different specimens ; one of these was extremely vigorous, and the other the reverse. The effect of the poison on the robust specimen consisted in depressing the pulsation, and reached its maximum some fifteen minutes after application. But subsequently the plant appeared to shake off the influence of the poison, and the pulses slowly recovered, till in the course of an hour they had once more become normal. The effect on the weakly specimen, however, was somewhat different. Instead of depression, the immediate result of application was a transi-

tory exaltation of the amplitude of oscillation, which was doubled, though at the same time the rhythm became slowed. After ten minutes, however, these pulsatory movements grew irregular and depressed, and the plant succumbed to the action of the toxic agent, its pulsation undergoing complete arrest forty-five minutes after application. In the case of a weakly specimen, again, on filling the chamber with an atmosphere of carbonic acid gas, the pulsations soon come to a stop, and unless fresh air be quickly introduced, this arrest becomes permanent. But with a vigorous specimen, the depression produced by this gas is very slow, and the permanent arrest does not take place till after a considerable lapse of time.

The effect of an agent, again, depends on the strength of the solution, and the duration of application. A solution which, in larger quantities, would produce depression, will often, if given in very diluted form, cause the exaltation of response. The sudden introduction of an agent which may ultimately produce arrest, may act as a transitory stimulus, bringing about a preliminary augmentation of response, to be followed later by depression and arrest. The application of a deleterious substance, again, for a short time, will cause a temporary depression, from which there is revival; but too long-continued action of the same reagent will cause permanent arrest. Besides all these, there is the interesting phenomenon of accommodation, by which the plant becomes gradually accustomed to the action of any adverse circumstance, and is thus rendered immune.

Effect of anæsthetics.—Taking a specimen of *Desmodium*, I passed ether-vapour into the plant chamber. The pulsatory movement which had hitherto been fairly uniform now showed a transitory exaltation, and then fell with remarkable regularity of decrement. The response next showed an equally regular tendency towards the gradual recovery of its previous amplitude, but with longer period, this being protracted, from the normal two to four minutes. Finally, the pulsation of this specimen was abolished, the leaflet remaining in a position of relative relaxation, thirty

Y 2

minutes after the first introduction of ether into the plant chamber. On blowing off the ether-vapour, there

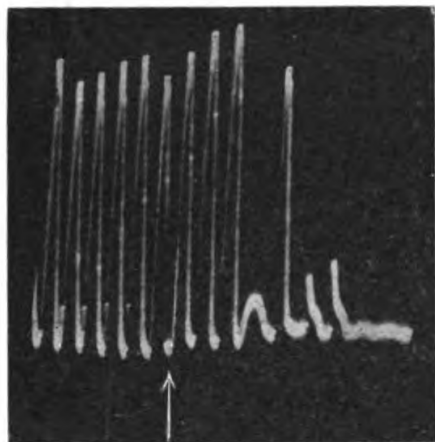

FIG. 130. Photographic Record of Effect of Ether Vapour, Large Dose

Arrow marks moment of application. Pulsation arrested in up, or relaxed, position. It has to be remembered that the up movement of the record corresponds to a down movement of the leaf.

was in this case no revival of response. In those cases, however, in which the ether-vapour is more diluted with air, or applied for a shorter period, the depression is temporary only, and is followed by revival. But if a larger quantity of ether-vapour be at once introduced, a permanent arrest, in the relaxed position, quickly ensues. Before this happens, there may be one or two spasmodic flutterings, but these quickly subside, as will be seen in the photographic record given (fig. 130).

Effect of alcohol.—The effect of this reagent is much modified by the tonic condition of the specimen. For example, in the case of a weaklier plant, the application, even of dilute solutions, induces rapid diminution and arrest of pulsation. More vigorous specimens can, however, withstand the deleterious effect of this drug, and bear stronger doses. In the photographic record here given (fig. 131) a 5 per cent. solution is seen to induce a greater regularity and amplitude of pulsation. The subsequent application of a 10 per cent. solution causes a moderate, and 15 per cent. a still greater, depression. The application of a 5 per cent. solution to a weakly specimen, however, is found, as said before, to induce a depression so great as to cause a speedy arrest.

Effect of carbonic acid.—The first effect of the introduction of this gas is sometimes one of exaltation. This is however, brief, and is followed by depression and sudden permanent arrest of pulsation in weaklier specimens. In

other cases, again, an earlier re-introduction of fresh air into the chamber is sufficient to restore the specimen to its

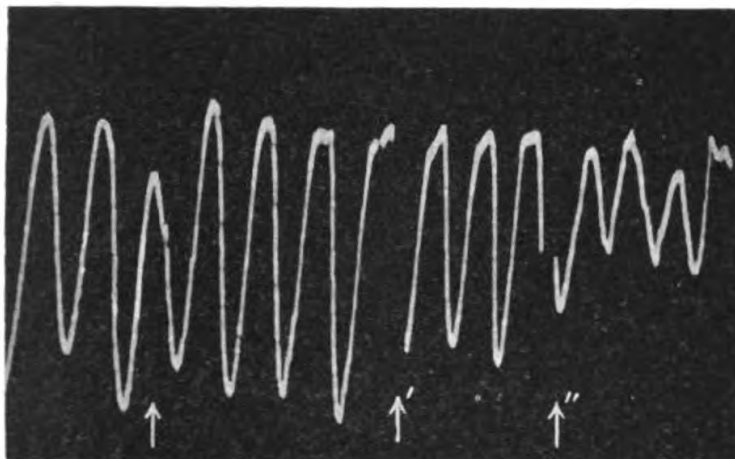

FIG. 131. Photographic Record of Effect of Alcohol
Pulsations to left show normal response. ↑ Marks application of 5 per cent. solution; ↑' application of 10 per cent.; ↑'' application of 15 per cent.

natural pulsatory activity. I give here (fig. 132) a photographic record of the effect of this gas on a vigorous specimen, in which its action is seen to be somewhat gradual. One curious phenomenon which I have noticed in connection with the effect of this gas, is that when it remains stagnant in the chamber its depressing effect is much more rapid than when a current is allowed to stream through.

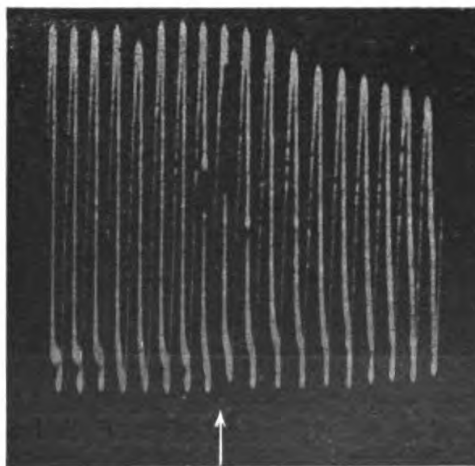

FIG. 132. Photographic Record of Effect of Carbonic Acid Gas
Arrow marks moment of application.

In the manner which I have just described, I have carried out further a number of experiments on the action of various gases and vapours, such as ammonia, carbon disulphide, and others, all of which

are found to cause an arrest of the rhythmic movements of *Desmodium*. It is not necessary to go into these in detail, the experiments already given affording sufficient information for their successful repetition.

I will only mention here the very interesting and important fact, that I find acids and alkalies, generally speaking, to produce effects which are in a certain physiological sense antagonistic. These effects, together with the influence of temperature on rhythm, and the action of tetanising electric shocks on the autonomous movements of *Desmodium*, will be found fully described in Chapters XXVI. and XXVII., where the remarkable parallelism of their influence on rhythmic animal and vegetable tissues will be demonstrated. I shall conclude the present chapter by describing the action of a strongly poisonous reagent on the pulsatory movements of *Desmodium*.

Effect of copper sulphate solution.—I carried out two experiments on similar specimens to test the effect of

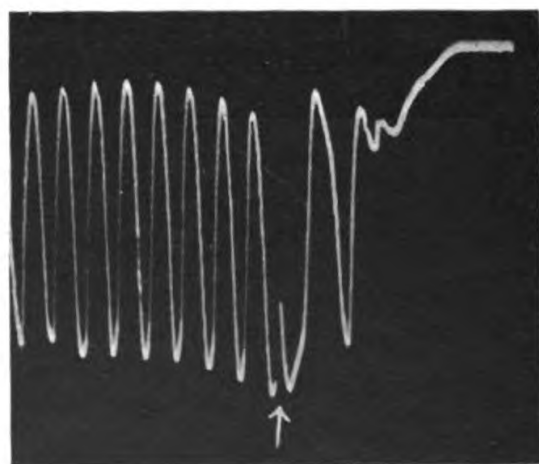

FIG. 133. Photographic Record of Effect of Copper Sulphate Solution Applied on the Pulvinus

Arrow marks moment of application.

this reagent. In the first, the solution was applied directly on the pulvinus, and produced a very quick arrest of its rhythmic activity (fig. 133). In the second case, the application was made at the cut end of the petiole, which was at a distance of 2 cm. from the pulvinus. In this case the arrest took place much later, that

is to say, thirty minutes after the application. This delay was due to the fact that the poisonous solution had to ascend the intervening distance before it could affect the rhythmic activity of the tissue at the pulvinus. This experiment will

be found important, as touching a later investigation on the ascent of sap. It is to be noticed that the petiole allows the poisonous solution which kills it to pass upwards through it.

Spark-record of pulsation of *Desmodium*.—Before ending this chapter, I shall give a spark-record of a single pulsation in a leaflet of *Desmodium*. The successive sparks were produced at intervals of 5 seconds, and a glance at the record affords a visual demonstration of the peculiar characteristics of the movement of the leaflet. The up line as usual indicates down movement. It is thus seen that, after a pause in the highest position, a sudden excitatory impulse is developed, which is gradually exhausted, as the lowest position is reached. The up movement takes place more gradually, and at a much slower rate. The results are shown in the following table.

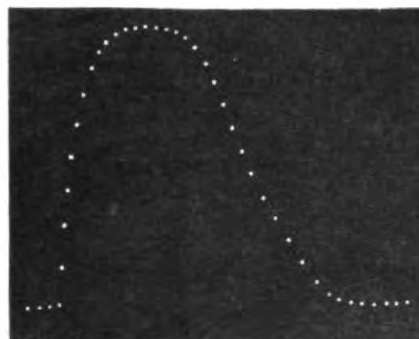

FIG. 134. Spark-record of Single Pulsation in Leaflet of *Desmodium*

Interval between successive sparks = 5 seconds.

TABLE SHOWING RATES OF MOVEMENT AT DIFFERENT STAGES OF PULSATION IN *DESMODIUM*.

Down movement		Up movement	
Total period	. . . 45 seconds	Total period	. . . 70 seconds
Average rate	. . . 61 mm. per sec.	Average rate	. . . 4 mm. per sec.
Maximum rate	. . . 7 " " "	Maximum rate	. . . 5 " " "
Duration of pause	. . . 40 seconds	Duration of pause	. . . 35 seconds

SUMMARY

The effect of a chemical reagent on a plant is modified to some extent by the tonic condition of the tissue. A vigorous plant will, generally speaking, withstand for a considerable time the action of deleterious agents; a weakly specimen succumbs more quickly.

The effect of a reagent depends also on the strength of the solution. A reagent which, in strong solution, induces depression, may, if given in small quantities, cause exaltation.

The effect of a reagent depends also on the duration of application. The temporary depression produced by a short application is overcome by the self-accommodation of the plant. But it will succumb to too long or too strong an application of the same reagent.

The effects of the various reagents on autonomous response are, generally speaking, similar to their effects on simple response.

The depressed position of the leaflet of *Desmodium* represents a 'systolic' contraction, and the up position a 'diastolic' relaxation, of the motile organ. Increased internal hydrostatic pressure increases the extent of the relaxed or 'diastolic' limit.

The effect of too strong an application of ether is to abolish response, the arrest of pulsation usually taking place in a relaxed position. The immediate effect of application is generally a transient exaltation of response.

The effect of vapour of alcohol is usually a transient exaltation. If the application be prolonged, the result is a permanent arrest of pulsation.

Carbonic acid sometimes produces a transient exaltation of response, and always a subsequent depression, which, under the long-continued action of this gas, may pass into permanent arrest.

Copper sulphate solution, when applied directly on the pulvinus, quickly causes arrest of pulsation; but if the cut petiole be allowed to absorb the solution, the final arrest does not take place till after the lapse of a certain period, required for the solution to ascend to the motile organ.

CHAPTER XXVI

EFFECTS OF TEMPERATURE ON AUTONOMOUS RESPONSES

Increase of frequency and diminution of amplitude of pulsation with rising temperature—Converse effect of fall of temperature—Similar effect in cardiac pulsation—Effect of the reduction of temperature to the thermo-tonic minimum—Explanation of diminution of amplitude of pulsation with rise of temperature—Anomalous use of the word 'relaxation'—Simple *versus* additive character of individual pulsation.

IT is my intention in the course of the next chapter to make a comprehensive review of the similarities in all their characteristics of rhythmically responding tissues, both vegetable and animal. In the present chapter, then, we shall confine our attention to a study in detail of the influence of temperature in modifying the amplitude and period of rhythmic autonomous responses, exemplified in the case of plant-tissues by *Desmodium* and in that of the animal by cardiac muscle.

As then we are about to study the effect of temperature on the period and amplitude of vibration of the *Desmodium* leaflet, it is clear that our first difficulty must be the securing of a specimen in which both are, to begin with, more or less uniform; for the pulsation of *Desmodium*, like that of the isolated frog's heart used for experiments, is often irregular. It is thus only by careful selection that one can obtain suitable experimental subjects. A moderate increase of the internal hydrostatic pressure, however, will often have the effect of rendering the responses sufficiently uniform.

Regulation of temperature.—The second difficulty in this investigation lies in subjecting the plant to the required rise or fall of temperature. A rise of temperature may be secured by any one of three different methods. (1) A spirit

flame may be applied underneath a bath of water in which the leaflets are placed. The temperature is thus gradually and continuously raised, and the successive pulsations, corresponding to different temperatures, are recorded in the usual manner by means of the Optic Lever. (2) Water at the required temperature may be syphoned into the bath, and the responses taken in the ordinary manner. (3) The air chamber in which the specimen is placed may be subjected to electric heating. The use of temperature may now be very accurately regulated by adjustment of the current, and records of pulsations may be taken at different and determinate temperatures.

This last is the most perfect method, the two former, dependent as they are on the immersion of the specimen in a bath of water, having as compared with it many disadvantages. For the natural freedom of movement of the leaflet is hampered by the water, and more troublesome still is the difficulty which at times arises from capillary action in the partially immersed cocoon-thread, by which the leaflet is attached to the Optic Lever outside the bath.

But we have not the same perfect facilities for lowering temperature in a gradual and continuous manner, as for raising it. This may be accomplished, however, sufficiently well for our purposes: (1) by placing fragments of ice in the air chamber; or (2) the pulvinus of the leaflet may be touched with cold water which has been reduced to the required temperature by means of ice. I find, however, (3) that a much better method is that of placing in the air chamber a coil of thin-walled metallic tubing, preferably of highly conducting copper. When cooled brine is made to circulate through this coil, the temperature of the chamber is lowered, and by regulation of the flow, by means of stop-cocks, it is possible to produce an adjustment of cooling.

Effect of temperatures maximum and minimum.—

Autonomous vibrations come to a stop when the temperature is sufficiently lowered. The temperature minimum at which this occurs depends, as we should expect, on the nature of

the specimen—whether *Desmodium*, *Biophytum*, or cardiac muscle—and also, with similar specimens, on the tonic condition. With regard to the first of these points, we have seen that the autonomous vibration of *Biophytum* comes to a stop below 29° C. The pulsation of *Desmodium* is said to be arrested at 22° C., but I find that this is a matter which is much modified by the tonic condition of the particular plant. With vigorous specimens I have seen that the vibration may persist even at so low a temperature as 17° C. The thermo-tonic minimum in *Biophytum* and *Desmodium* thus shows a difference, as already said, of about 12° C.; and in the case of the frog's heart this is still lower, and is said to be about 0° C.

When, again, the specimens are raised to a maximum temperature, the pulsations come to a stop. The temperature at which this takes place depends in part on the condition of the specimen. For example, with the frog's heart, this maximum is sometimes at a temperature so low as 38° C. In other cases, pulsation may be detected even at so high a temperature as 44° C. Similarly, in *Desmodium*, I have found that the maximum temperature at which arrest took place was sometimes as low as 35° C.; but in certain specimens it did not occur till 45° C. A plant may, again, be accustomed gradually to high temperatures, and under these circumstances the maximum may be raised as much as 3° C. or 4° C. higher.

Effect of temperature on period and amplitude of response.—The most marked phenomenon of effect of temperature on automatic pulsations, whether animal or vegetable, lies, however, in the fact that the period and amplitude are both affected. When the temperature is lowered, the amplitude of pulsation is enhanced, while the frequency is diminished. Conversely, with rise of temperature, the amplitude is diminished, and frequency augmented. This is true not only of the pulsations of the rhythmic tissue of *Desmodium*, but also of those of the animal heart. This is seen in the two following records, where the first

set of responses in each series gives pulsations at the temperature of the room, while the second set in each gives pulsations of greater amplitude and smaller frequency, due to the lowering of temperature by several degrees (figs. 135, 136). Conversely, as already said, when the temperature is raised, the frequency is increased and the amplitude decreased. This is seen in a general way in the following photographic record (fig. 137), which I took with

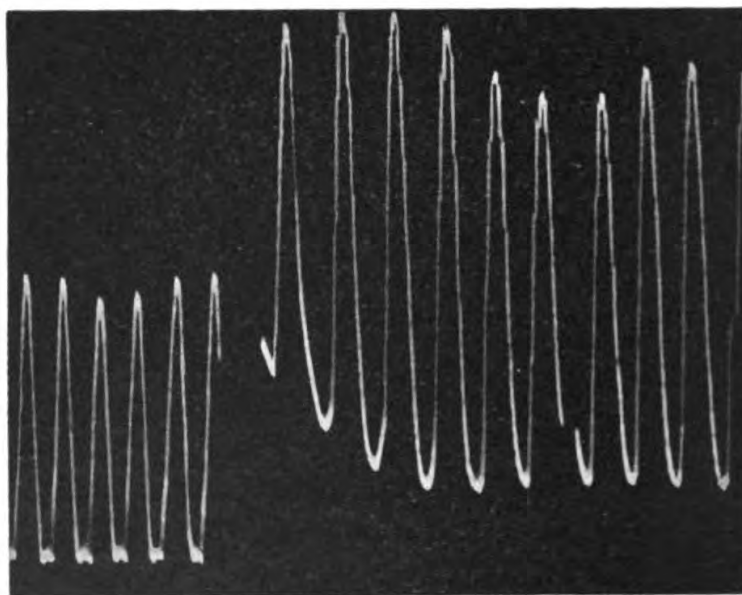

FIG. 135. Photographic Records of Autonomous Pulsations in *Desmodium*, showing Increase of Amplitude and Decrease of Frequency, with Lowering of Temperature

The pulsations to the left were taken at the ordinary temperature of the room, 29° C. Those to the right were taken when the temperature had been lowered to 25° C.

Desmodium, the temperature being continuously raised, from 30° C. to 39° C. It will be seen how progressive in character is the diminution of amplitude and increase of frequency in these responses.

In another set of experiments in which I took records of the responses of *Desmodium* at various definite ascending temperatures, I found that at 19° C. the period of a single oscillation was 4.3 minutes. At 22° C. this was reduced to

3.2 minutes, or nearly to two-thirds of the period at 19° C. At 28° C. it was found to be again reduced to 2.1 minutes, or half. But at 40° C. it was only 1.4 minute, or one-third. Thus, while in 4.3 minutes, at 19° C. there is only a single beat, there are two beats at 28° C. and three beats at 40° C. in the same time. I give below (fig. 138) a record of these responses at various temperatures. The record given afterwards (fig. 139) shows how similar is the effect of temperature on the amplitude and rhythm of the pulsation of the animal heart. When the temperature of *Desmodium* is raised above 40° C. there appears to be an arrest of pulsation. But this need not be

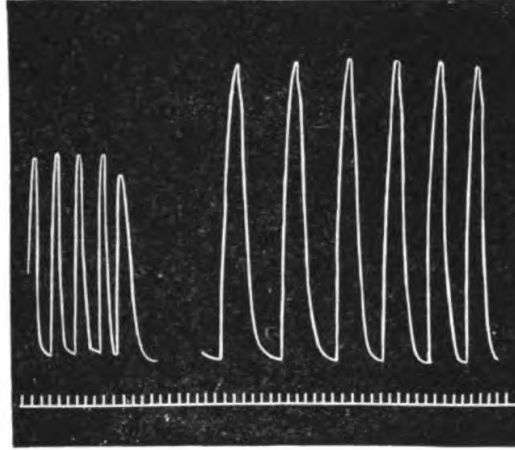

FIG. 136. Effect of Lowering of Temperature in Producing Increase of Amplitude and Decrease of Frequency in Pulsation of Frog's Heart

The pulsations to the left represent normal pulsations at the temperature of the room. Those to the right were taken at a temperature several degrees lower (after Brodie).

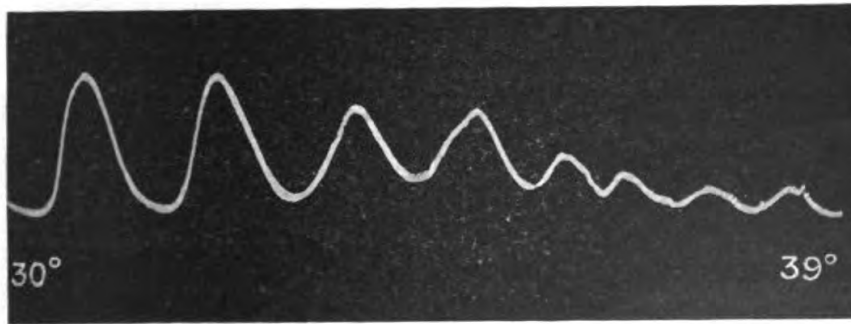

FIG. 137. Photographic Record of Pulsations of *Desmodium* during Continuous Rise of Temperature

regarded as due to heat-rigor. For in magnified records I have often noticed that here we may have very much

quicker pulsations, but of an amplitude so small as usually to pass undetected. It is only under prolonged exposure to this relatively high temperature, or after exposure to a temperature above 50°C ., that true heat-rigor sets in. This maximum temperature varies in individual cases with the tonic condition of the plant.

Effect of the reduction of temperature to the thermo-tonic minimum.—It has been said that, generally speaking, the amplitude of response increases with the lowering of temperature. It is evident, however, that this process must have a limit. For we know that pulsation vanishes at the thermo-tonic minimum; before this reduction of amplitude to zero it is clear that there must be some point where the increase of amplitude due to continuous cooling must undergo reversal, or diminution. And this is what we should theoretically expect, for since it is the absorbed

thermal energy that maintains the pulsation, it follows that, when this is diminished below par, the vibrational energy

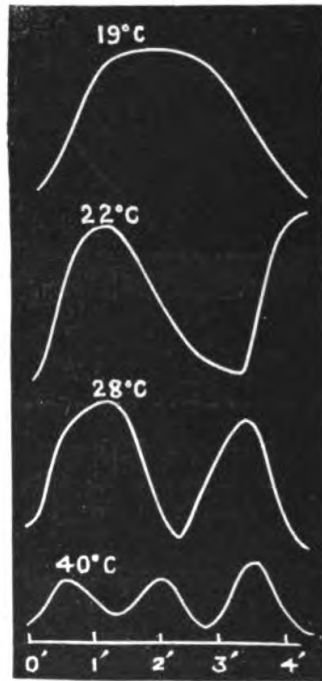

FIG. 138. Record of Pulsations of *Desmodium* at Different Temperatures

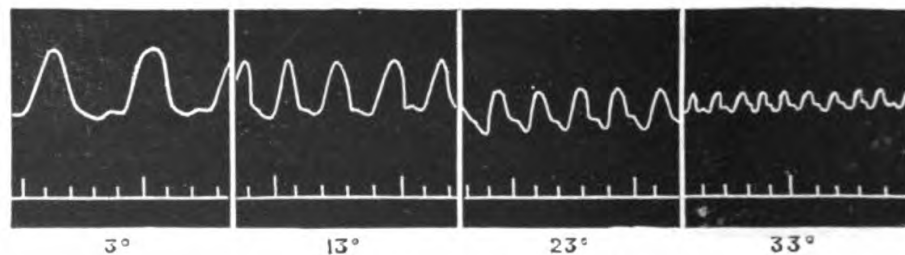

FIG. 139. Record of Pulsations of Frog's Heart at Different Temperatures (Pembrey and Phillips)

should also undergo diminution. We had an illustration of this (p. 305), when the automatically vibrating *Biophytum*

at 35° C. was allowed to descend to the thermo-tonic minimum. It was in that case found that there was a regular diminution of amplitude, and the pulsation afterwards disappeared below 29° C. (fig. 124).

I was next desirous of determining whether this theoretical inference could be verified in the case of *Desmodium*. For this purpose I rapidly cooled the plant, by means of the cooling coil, through which ice-cold brine was passed, a

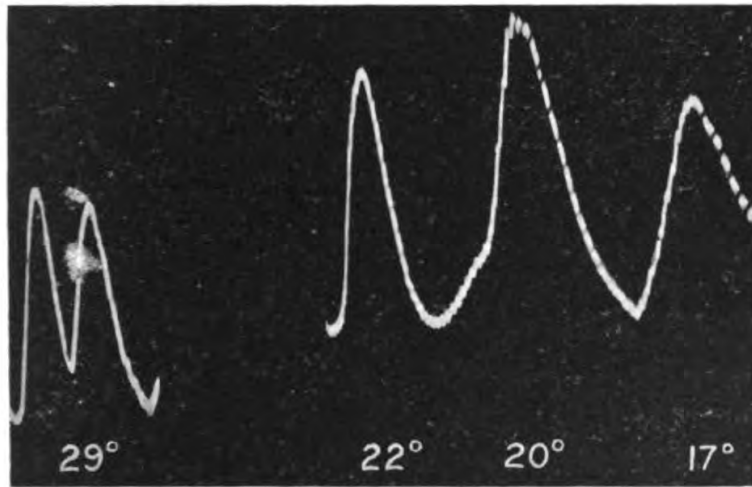

FIG. 140. Effect of Cooling to Thermo-tonic Minimum on Pulsation of *Desmodium*

The first two pulses to the left were taken at the normal temperature of 29° C. ; those to the right during continuous cooling. The first response of the latter series occurred at 22° C. ; the second at 20° C. ; and the third at 17° C. Note that while in normal responses there are no sub-pulses, these are seen with increasing distinctness as the pulsation becomes continuously slower. They first make their appearance during the up movement of the first pulsation under cooling. In the two successive pulsations they are seen more and more clearly in the down as well as the up movements.

photographic record being taken of the pulsations all the time. It will be noticed that the first effect of cooling was the normal increase of amplitude and prolongation of period. This latter—which at the temperature of the room had had a value of three minutes—was now prolonged to nearly six minutes. But the most interesting fact was that, as the thermo-tonic minimum was approached, the amplitude was reduced (fig. 140).

In the next experiment cooling was produced more suddenly, by application of cold water at about 4° C. to the pulvinus. We observe in this case how the quick reduction to the thermo-tonic minimum reduced the amplitude till the pulsation had come to a stop. I then allowed the leaf to return gradually to the temperature of the room, and it is very interesting to note the effect of increasing

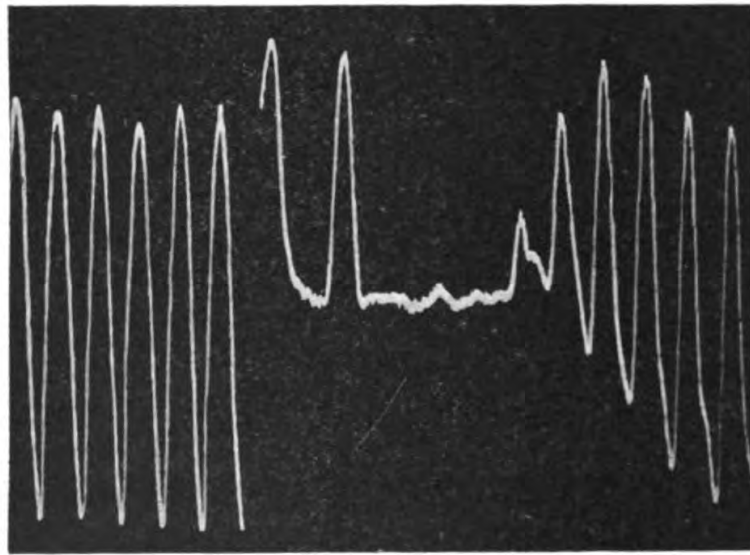

FIG. 141. Effect of Rapid Cooling by Ice-cold Water

Normal pulsations recorded to the left. Effect of application of ice-cold water is seen in the production of diminished amplitude and abolition of pulsation. Gradual return to the temperature of the room revives the pulsation in a staircase manner, the period remaining approximately constant. Note that cooling, in this and previous figure, displaced the pulsation in a downward or contracted direction. Gradual warming, conversely, is seen in this figure to produce the opposite displacement towards relaxation.

absorption of thermal energy from its surroundings. The increased energy thus absorbed is seen to give rise to increased amplitude of oscillation, in a staircase manner, which gradually approaches the original pulsation (fig. 141). In both these figures it will be noticed that cooling displaces the pulsation in a downward or contracted direction. And in the last series of fig. 141 we see that the raising of the

temperature displaces it upwards or towards relaxation. These facts are of great importance, and should be borne in mind in reference to the explanation of the cause of variation of amplitude and period, which I shall bring forward.

Explanation of diminution of amplitude of pulsation with rise of temperature.—We have thus seen, as we should theoretically have expected, that with the increased absorption of energy at a higher temperature, the amplitude of vibration is also increased. How is it, then, that with the still further increase of absorption of energy, at still higher temperatures, the amplitude should undergo a diminution? When approaching the maximum point, where heat-rigor takes place, we can understand that the excitability of the tissue would be very much decreased, with a consequent reduction of amplitude of pulsation. But at temperatures of 25° C. to 30° C. excitability of the tissue could not be diminished. Indeed, I shall in Chapter XXXIII. adduce considerations to show that it must, at that temperature, be highly excitable, and we should have expected that this would have produced, in addition to the increased energy, an augmentation of vibrational amplitude. But, instead of this, we obtain the curious result which has been described, of a diminution, in the cases both of cardiac muscle and of *Desmodium*.

It might be suggested that if increased activity, due to rise of temperature, increased the frequency of vibration, then this fact would be sufficient in itself to account for a diminution of amplitude; for in this case, less time being allowed for each single vibration, its extent must be curtailed. But this consideration alone would not explain all the facts of the case; for we have seen that on approaching the thermo-tonic minimum, though the frequency of vibration is reduced, and the period very much extended, yet the amplitude is also at the same time decreased (fig. 140). We thus see that the question of internal energy is important in this connection. An increase of internal energy may be expressed, as I shall show, in two different ways; either, that

Z

is to say, by increase of amplitude or by increase of frequency of pulsation.

Increased internal energy, shown by: (a) *Increase of amplitude, period remaining constant.*—And we shall, as the simpler of the two, consider that case in which the latent energy, or tonic condition of the plant, is below par, that is to say, the case in which it is near the thermo-tonic minimum. The effect of increased absorption of energy with rising temperature would here be indicated by increasing amplitude of pulsation, *the period remaining constant.* Conversely the reduction of latent energy with falling temperature would be indicated, when the period is constant, by the fall of amplitude. This we find fully illustrated in records obtained with *Biophytum* and *Desmodium*. In the former, when nearing the thermo-tonic minimum, it is found that while the period remains approximately constant, that is to say, two and a half minutes, the amplitude of pulsation falls from 8 divisions at 35° C. to 5.5 divisions at 32° C. (fig. 124). In *Desmodium*, again, we find a converse case. Here, while the plant is rising from the thermo-tonic minimum to the normal condition, the amplitude of pulsation is seen to increase progressively, while the period of 2.4 minutes remains constant (fig. 141).

(b) *Increase of frequency.*—Taking next the case of a plant in the ordinary tonic condition, we find that the increase of internal activity, due to the greater absorption of energy during a rise of temperature, is exhibited by a higher frequency of vibration. The reason why, with this increase of frequency, there is a diminution of amplitude of pulsation, is now to be explained.

We have seen that an increase of internal energy, as caused by rise of temperature, brings about an increase of turgor, and that this increased turgor hastens the process of recovery, and by acting antagonistically to the contractile phase of responses diminishes its amplitude. Increased internal pressure also, generally speaking, increases the frequency of vibration. If, then, the rise of temperature increases the turgor of *Desmodium*, as we have found it to do

in plants in general, then the diminution of the amplitude of its vibration with higher temperature is explained; and I shall be able to adduce independent proof that this is actually the case in *Desmodium*, for we have seen that the external indication of internal increase of turgor is the expansion of the organ, which produces a movement upwards, the same as that of relaxation. We found in the last series of responses in fig. 141, moreover, that when the temperature was raised gradually from the thermo-tonic minimum, the leaflet was more and more erected, or 'relaxed.' Cooling, conversely, produced diminution of turgor, and an opposite movement in the direction of fall or contraction (figs. 140 and 141).

The anomalous use of the word 'relaxation.'—We have seen that the motile organ of *Desmodium*, when anæsthetised, is brought to a state of standstill in a position of relaxation. Its tonic condition, by virtue of which it exhibits contractile response, has thus been abolished. We may then regard ether as having brought about a loss of tone, or as having reduced the tissue to the a-tonic condition.

An apparently similar position of relaxation may, however, be attained by the *active* process of expansion, which is the result of an increase of internal turgor. It would thus appear that we are liable to form many wrong inferences, as to the tonic changes undergone by the organ, if we too hastily conclude that expansion is always caused by loss of tone.

Simple versus additive character of individual pulsations.—One question, regarding which opposite views have been put forward hitherto, is that of the simple or composite nature of the individual pulsations of cardiac muscle. The movement of systole may, for example, be regarded as consisting either of a single or of the additive effect of several constituent contractions. In the production of tetanus in the case of muscle and also in that of contractile vegetable tissue we have seen several individual contractions, when following each other with sufficient rapidity, become merged in one apparently continuous contraction (figs. 49, 50). When less rapid, however, they are individually distinguishable. Similarly,

in the case of cardiac pulsation, it is possible that one apparently simple contraction may in reality consist of several, which are rendered indistinguishable by the great rapidity of their succession.

Now, since the pulsatory response of *Desmodium* is in every way so similar to that of cardiac muscle, its analysis might be expected to throw much light on this question; and this more especially since it possesses the added advantage that its pulsation is executed in a period about one hundred times as long as that of cardiac muscle. The constituent

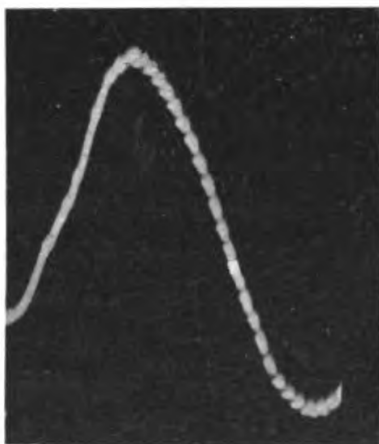

FIG. 142. Photographic Record of Pulsation of *Desmodium*, showing Sub-pulses during slower Up Movement, as Nodules

elements of each pulsation, if such exist, ought thus, owing to the relative slowness of the movement, to be much more easy of detection. Now, it is often seen in watching the pulsatory movements of *Desmodium* that they proceed somewhat discontinuously, or by jerks. Under favourable circumstances, nevertheless, the movements of the leaflet up and down become apparently continuous. When such pulsations are recorded on a rather rapidly moving drum, the discrete nature of the movement can be brought out more easily in

the case of the up movement, which is relatively slow. This is shown in a very interesting manner in the accompanying photographic record (fig. 142), where the subsidiary pulsations make themselves visible as nodules; places where the movement is slow appear thicker, on account of the photographic irradiation-effect. During the course of the single up movement recorded in this photograph, we may count as many as twenty-five of these sub-pulses. It has been said that these subsidiary movements are more easily detected when the general movement is relatively slow; and in connection with this, it is extremely interesting to note the record of pulsations

seen in fig. 140, where successive pulsations of the same leaflet, at first apparently continuous, are made to exhibit the sub-pulses with growing distinctness, as the period becomes progressively slowed down by cooling. First we are enabled to observe the sub-pulses during the up movement, and afterwards during the down movement also. I give another photographic record also (fig. 143), in which these subsidiary pulses are seen at both the 'systole' and 'diastole' (see also fig. 175). Arguing from analogy, therefore, it becomes highly probable that any single pulsation of the heart also may be made up of similar discrete and constituent elements.

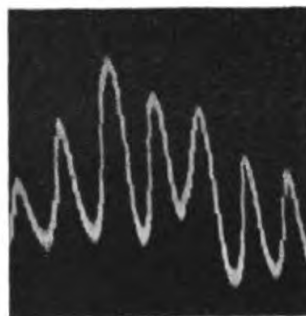

FIG. 143. Photographic Record of Cyclic Groupings in Autonomous Pulsations of *Desmodium*, showing Sub-pulses

While dealing with this question, it must be borne in mind that in each case the contractile organ as a whole is

made up of a mass of individually contractile elements, the sum of whose separate and additive actions it is which is seen as a single contraction and expansion of the whole organ. Thus, in *Desmodium* for example, a single pulsation of the motile organ is made up of subsidiary pulselets. The unit-pulses, again, may themselves be grouped in larger systems, either as the alternate waxings and wanings seen in periodic groupings (figs. 143 and 149), or in those periodicities of

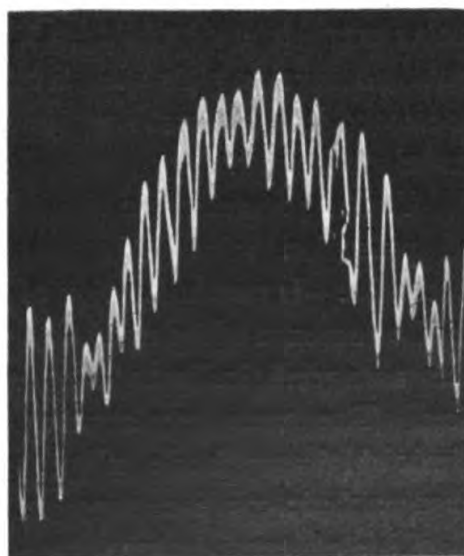

FIG. 144. Photographic Record of Autonomous Pulsation of *Desmodium*, showing Hourly Period

[Speed of drum = 5 cm. in one hour.]

the order of an hour or so, which the plant sometimes

exhibits, under the influence of periodic variations of temperature and other factors. An extremely interesting example of such an hourly periodicity is given above (fig. 144), where the mean plane of vibration is itself seen to exhibit a periodic up-and-down oscillation. There is, again, the still larger periodicity of diurnal variation of day and night. We thus see how complex may be these wave-systems, in which, superposed over large waves, are smaller waves, and on the latter still smaller wavelets.

SUMMARY

In *Desmodium*, as in cardiac muscle, rise of temperature produces increased frequency with diminished amplitude of pulsation. This is true within a certain normal range of temperature. When the temperature of *Desmodium* is reduced to a thermo-tonic minimum—which is about 17° C. but subject to certain individual variations—the amplitude of pulsation, owing to the loss of internal energy, is decreased till there is an arrest. If now the temperature be gradually raised, the pulsations, owing to the absorption of energy, become again increased in a staircase manner, the period remaining approximately constant.

Under normal tonic conditions, the decrease of amplitude of pulsation with rising temperature—when this is not excessive—is not indicative of loss of excitability. It is due to the increase of internal energy, which hastens recovery and acts antagonistically to the responsive movement of contraction. The same explanation is probably applicable to the diminished amplitude of pulsations with rise of temperature, observable in cardiac response.

Rise of temperature, by increasing the internal energy and consequent turgor of the plant, causes expansion of the organ, thus bringing about a shifting of the pulsation towards 'diastole.'

A converse effect, or shifting towards 'systole,' is seen in *Desmodium*, as the result of cooling.

The process of relaxation in the motile organ may be the result of entirely different causes. It may be a consequence of a loss of tone, such as results from narcotisation; or it may be brought about by excessive turgor, caused by increased internal energy.

The apparently simple rhythmic pulsations of *Desmodium* can be analysed and shown to consist of subsidiary minor pulsations. The ordinary pulsations, again, may show hourly and daily periodicities.

CHAPTER XXVII

SIMILARITIES OF RHYTHMIC RESPONSE IN VEGETABLE AND ANIMAL TISSUES

The similarities, in their fundamental characteristics, of rhythmic tissues, animal and vegetable : (1) In responses—(2) In possession of long refractory periods - (3) In incapability of tetanus—Theories regarding the causation of heart-beat—The similarities of rhythmic tissues, animal and vegetable, as seen in : (1) The effects of internal hydrostatic pressure—(2) The effects of variation of temperature—(3) The periodic groupings of response—(4) The effect of barium salt—(5) The antagonistic actions of acid and alkali—Identity of rhythmic phenomena in animal and vegetable tissues.

I HAVE, in the course of the previous chapters, shown the remarkable general similarities, extending through numerous details, between the responses in animal and vegetable tissues. These similarities, however, become still more striking when we compare the special characteristics of those plant and animal tissues which exhibit the property of rhythmicity—that is to say, those tissues which, under the action of a single strong stimulus, give rise to a multiple and rhythmic series of responses, such responses, under favourable circumstances, passing into the so-called automatic movements.

In animal tissues, such rhythmic movements may be observed in their perfection in the case of cardiac muscle. The isolated heart, when brought to a state of temporary standstill, will give, in answer to a single stimulus, a single response, or to a sufficiently strong stimulus a multiple series of rhythmic responses ; and under favourable circumstances it will give automatic responses for a considerable length of time.

Similarly, the plant *Biophytum*, under exceptionally favourable circumstances, exhibits what are apparently automatic responses ; and again, under ordinary conditions it

gives a single response to a single stimulus, or if the stimulus be sufficiently strong, a multiple series of rhythmic responses. In the plant *Desmodium*, under favourable tonic conditions we observe automatic movements ; but when under less favourable circumstances, as for instance owing to the unfavourable season, it is brought to a state of standstill, it gives a single response to a single stimulus. When the stimulus, however, is strong, we have seen that it gives rise to a multiple series of responses, in a manner precisely like that of *Biophytum* under similar circumstances. It will thus be seen that *Biophytum* in its ordinary condition may be regarded as equivalent to *Desmodium* in a state of standstill.

Similarities, in their fundamental characteristics, of rhythmic tissues, animal and vegetable : (1) In responses.— In the matter of response, we have found that the rhythmic automatic movements of cardiac muscle are repeated in *Desmodium* under ordinary tonic conditions, and in *Biophytum* under exceptionally favourable circumstances. In a state of standstill, all three give a single response to a single moderate stimulus, and a multiple series of rhythmic responses to a sufficiently strong stimulus. The following tabular statement exhibits this parallelism in a concise form :

TABULAR STATEMENT SHOWING SIMILARITIES IN THE RESPONSES OF RHYTHMIC ANIMAL AND VEGETABLE TISSUES

	At standstill		Under favourable conditions
	Moderate stimulus	Sufficiently strong stimulus	
Cardiac muscle	Single stimulus, single response	Single stimulus, multiple series of rhythmic responses	Automatic rhythmic movements
<i>Desmodium</i>	Do.	Do.	Do.
<i>Biophytum</i>	Do.	Do.	Do.

(2) *In possession of long refractory period.*—In order to study in detail the characteristics of response in *Desmodium*, I took a plant in which the leaflets had come to a state of natural standstill. To such a specimen I applied the stimulus of a condenser discharge; it was found, as stated already, that a rather high electromotive charge (twenty-four volts) was required to produce response. The first few responses were somewhat feeble, owing to the sluggish condition of the tissue; they then increased in a 'staircase' manner till they became uniform, the period of a complete response being now about six minutes. From this point on, the responses were the maximal possible, and a higher E.M.F. produced no noticeable increase. The most characteristic feature of these responses was the possession of a long refractory period, which we have also found to be characteristic of the response of *Biophytum*. With this specimen of *Desmodium* I found that when a second stimulus was given after three minutes, there was no further response. But a stimulus given after three and a half minutes was effective. It may be mentioned here that the length of the refractory period varies somewhat with the condition of the tissue, being relatively longer when that is sluggish.

(3) *In incapability of tetanus.*—The rhythmic tissue of *Desmodium* thus resembles cardiac tissue, in the possession

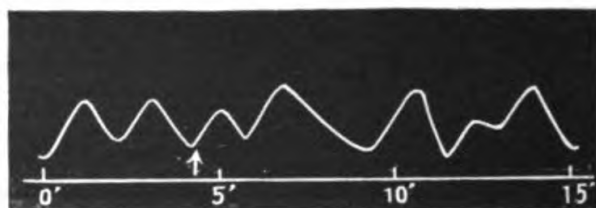

FIG. 145. Record showing that Rhythmic Tissue of *Desmodium* is Incapable of being Tetanised

After the first two pulsations, strong tetanising electric shocks were applied continuously. No tetanic effect was produced, but the pulsation became somewhat irregular.

of a marked refractory period. There is again another interesting similarity. A rhythmically beating cardiac tissue cannot be thrown into tetanus by quickly recurring electric

shocks. An automatically moving *Desmodium* leaflet is also incapable of being thrown into a state of tetanus (fig. 145). Rapidly succeeding shocks do not produce tetanic contraction, though some irregularity may occur in the pulsation; excessively strong shocks kill the plant, and the pulsation is then permanently arrested.

Theories regarding the causation of heart-beat.— Having thus seen how similar are the phenomena of rhythmicity in cardiac muscle and in plants, we may proceed to inquire into the theories which have been proposed to account for the automatic pulsation of the heart. It has been suggested :

(1) That discrete impulses are sent out from certain motor nerve-centres in the heart to the muscular tissue, thus causing the periodic heart-beat. Assuming the correctness of this theory, however, the difficulty is merely transferred, for we have still to account for the rhythmic excitation of the nerve. But that the rhythmic heart-beat is not fundamentally due to rhythmic impulses from nerve-centres, has been proved from facts discovered by various observers: (*a*) that the isolated ganglion-free apex of the frog's heart may be thrown into rhythmic activity by stimulus; it has also been shown by Gaskell (*b*) that the apex of the tortoise-heart, which is free from nerve-cells, is capable of rhythmic movements; and (*c*) it is found that even in the embryo, before any connection with the central nervous system has been established, there is a rhythmic heart-pulsation.

(2) That cardiac muscle may have the inherent property of rhythmicity. This explanation, however, by itself, is incomplete, for it takes no account of the stimulus which must exist, in order to give rise to rhythmic expression.

(3) That the pulsation of the heart is maintained by some 'inner stimuli,' its rhythmicity being brought about by the long refractory period peculiar to cardiac muscle.

Independent light, however, may be expected to be thrown on the question of the causation of spontaneous

rhythmic action in cardiac muscle, by the consideration of similar phenomena in plants, especially since it can be shown that their similarity is manifested under numerous varying conditions, and extends to fundamental characteristics.

We have already seen that there is a similarity of fundamental characteristics between the response of cardiac muscle and that of rhythmic vegetable tissue.

Similarities of rhythmic tissues, animal and vegetable.—We shall now, therefore, observe in detail those other and more special similarities which are exhibited in a common modification of response under varying external conditions, by *Desmodium* and cardiac muscle alike, and I shall first describe the remarkable effect produced on both by internal pressure.

(1) *The effects of internal hydrostatic pressure.*—It is found that a heart which has come to a condition of standstill may be set into rhythmic activity by filling the cavity of the heart with liquid. Endo-cardiac pressure is thus found to act as a stimulus.

In *Desmodium*, when the season is favourable, the tissue is in a turgid condition, and there is a considerable internal hydrostatic pressure, which we have seen to be advantageous to the maintenance of rhythm. This turgid condition depends on the ascent of sap, which, as I shall show in Chapter XXVIII., depends again on the rhythmic activity of certain tissues. Thus, in the summer season, we have the conditions most favourable for the maintenance of rhythmic activity in *Desmodium*. But with the approach of winter the vigour of the plant and its turgid condition undergo a marked decline, and the autonomous movement of the leaflet then comes to a stop.

It appeared to me that this cessation of movement might to a great extent be due to the diminution of internal hydrostatic pressure, and I undertook experiments to see whether the pulsatory movement could be renewed by an increase of this pressure, just as increased endo-cardiac pressure was found to renew the beating of the heart. The

experiment was carried out by mounting a detached petiole containing the motile leaflets at one end of a limb of a U-tube. Any desired pressure could be exerted by varying the height of the second limb, which was connected with the first by india-rubber tubing. By exerting internal pressure in this manner, I was able to produce vigorous rhythmic movements of leaflets which were, before this, in an absolutely quiescent condition. The

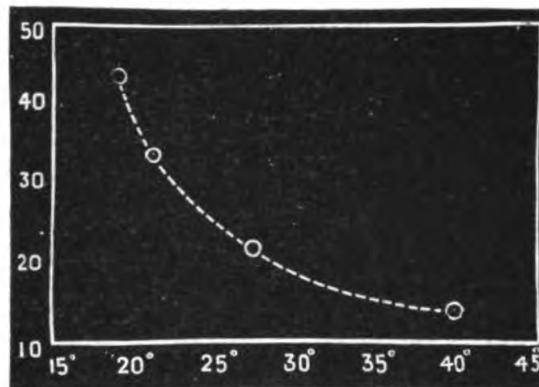

FIG. 146. Curve showing Relation between Temperature and Period of Pulsation in *Desmodium*

Abscissa represents temperature, and ordinate time, in tenths of a minute.

beneficial effect of this constant internal pressure was further seen demonstrated by the extreme regularity and persistency of the rhythmic beats.

Even in the best season of the year, the pulsations are irregular, and come to an occasional stop; but under the action of internal pressure, I have found the detached leaflet to maintain its rhythmic activity unimpaired for nearly one hundred hours. In connection with this question of the increase of internal pressure, it should be mentioned here that, after the normal condition of turgidity has been established, a further increase of internal pressure is found to increase the frequency of pulsation.

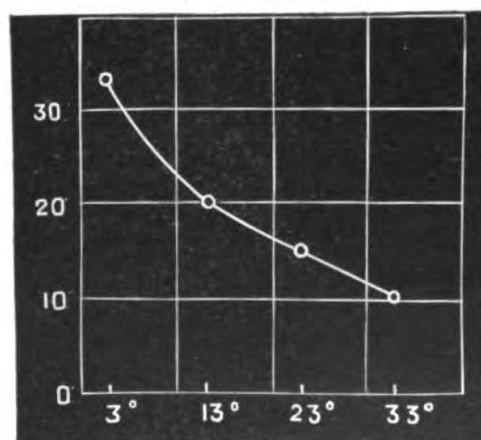

FIG. 147. Curve showing Relation between Temperature and Period of Pulsation in the Heart of a Frog

Ordinate represents time, in tenths of a second.

Excessive pressure, however, brings on irregularity, or even stoppage, of autonomous movement.

(2) *The effects of variation of temperature.*—I have shown in the last chapter how perfectly similar are the effects of temperature in causing variations of the amplitude and frequency of pulsation in rhythmic tissues, both vegetable and animal. As regards the effect of temperature on the period, the similarity is strikingly exhibited in the two curves given above, showing the relation between temperature and period in *Desmodium* and in cardiac muscle. It will be seen that in both (figs. 146 and 147) the fall of period with increase of temperature is at first rapid and then slow.

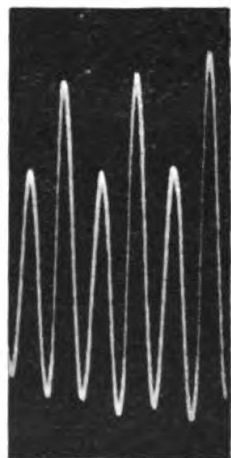

FIG. 148. Simple Alternation of Pulsation in *Desmodium*

(3) *Periodic groupings of response.*—Another very remarkable similarity between the pulsations of *Desmodium* and of cardiac muscle lies in their exhibition of periodic groupings, very simple types of which, given by *Desmodium*, are seen in the photographic records (figs. 148, 149). In fig. 146 we have an alternate waxing and waning of pulsation, and a remarkably similar record, given by frog's

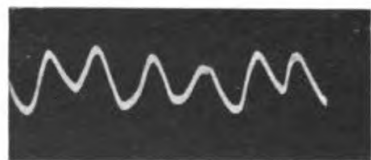

FIG. 149. Periodic Groupings of Pulsation in *Desmodium*

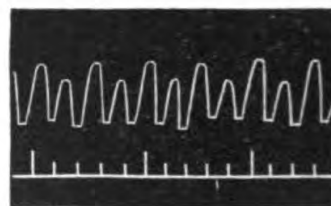

FIG. 150. Simple Alternation of Pulsation in Frog's Heart (Pembrey and Phillips)

heart, is seen in fig. 150. These groupings are of various degrees of complexity, one type of such heart-beats being that known as Luciani's groups, where the successive groups are separated by a long pause. Now, similar groups with

intermediate pause are also seen in the pulsation of *Desmodium*. I have again shown that periodic rhythms of various degrees of complexity are seen, not only in the pulsations of *Desmodium*, but also in the multiple responses of *Biophytum*, and even in the electrical responses in plants.

(4) *Effects of barium salt.*—There are agencies, such as internal pressure and certain chemical reagents, which induce regularity of pulsation in irregularly pulsating rhythmic tissues. Conversely, there are others, which produce the opposite effect, that is to say, a regular pulsation, after such an application becomes irregular.

When the heart pulsations are regular, it is found that addition of *Veratrin* disturbs the uniformity. Remembering the general similarity of the action of *Veratrin* and barium salts, I applied a 5 per cent. solution of this substance to the pulvinus of *Desmodium* leaflet, which was executing very regular vibrations. The application of this reagent disturbed the regularity of the pulsation, and somewhat irregular

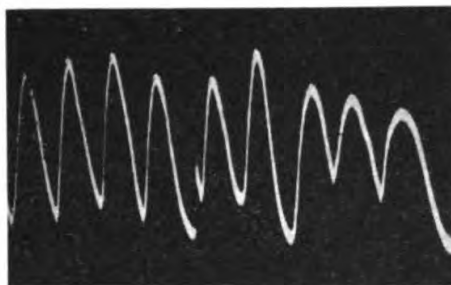

FIG. 151. Effect of Barium Chloride Solution on *Desmodium*

The regular pulsation, seen to the left, becomes irregular after application of this reagent.

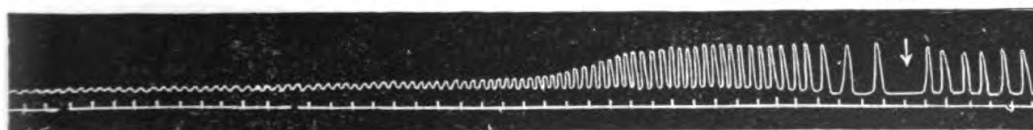

FIG. 152. Arrest of Beat of Ventricle of Frog at Diastole by Application of Acid at Arrow

Record to be read from right to left (Gaskell).

groupings were at once established (fig. 151). In another experiment with the same reagent, as the application of heat is known to neutralise the action induced by *Veratrin* and barium salts, I raised the temperature of the plant chamber, with the result that the beats became regular once more.

(5) *Antagonistic actions of acid and alkali.*—But the most remarkable of all the similarities seen in the pulsations of rhythmic tissues of animal and vegetable, is that of the antagonistic actions of acid and alkali. Acid induces in the case of the heart a relaxed or diastolic standstill, whereas



FIG. 153. Systolic Arrest of Heart-beat by Dilute NaHO Solution (Gaskell)

alkali induces an effect exactly the opposite, the standstill being brought about at systolic contraction (figs. 152 and 153). It is also known that the standstill caused by one of these reagents can be counteracted by the antagonistic action of the other.

It is astonishing to find that exactly the same effects are produced by these reagents on the tissue of *Desmodium*.

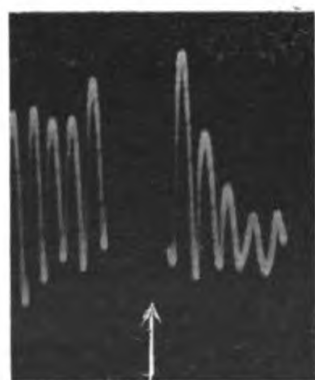

FIG. 154. Arrest of *Desmodium* Pulsation at 'Diastole' by Application ↑ of Acid

I first tried the effect of dilute hydrochloric acid, which, as will be seen, produced an arrest of pulsation in the 'diastolic' or relaxed position (fig. 154). I next tried the effect of alkali—dilute solution of sodium hydrate—and it will be seen that this produced an arrest of pulsation in the 'systolic' or contracted position (fig. 155). In records of the effect of this reagent on other specimens, in which its action had not proceeded so far, there was a continuous diminution of pulsation with a shifting

towards the systole; and when an acid was now applied, the antagonistic character of its action to alkali was clearly shown, by a gradual revival of response, with a shifting towards the diastole. In the present record, the systolic standstill caused by alkali was allowed to proceed far, and

yet on application of the acid there is seen to be a slight revival of pulsation and a final arrest towards diastole.

Identical nature of rhythmic phenomena in animal and vegetable tissues.—We have thus found the responsive phenomena of cardiac muscle to be in every respect similar to those observed in the rhythmic tissues of *Desmodium* and

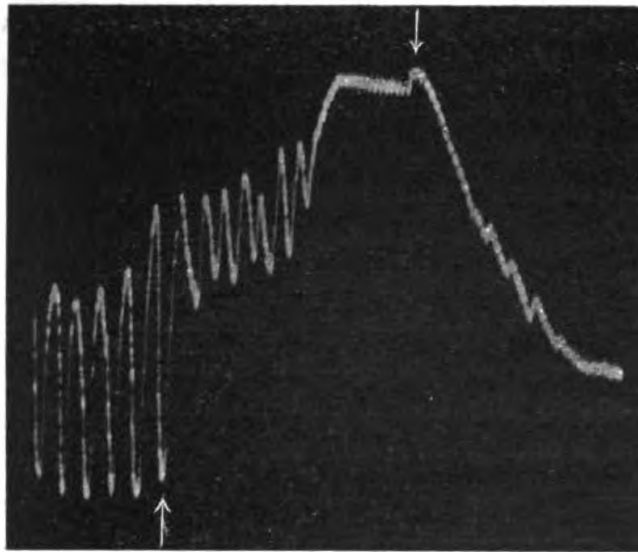

FIG. 155. Arrest of Pulsation of *Desmodium* at 'Systole' by Application of Dilute Alkali at ↑

Acid was next applied at ↓, and the record shows its antagonistic action.

Biophytum, the response of the latter being regarded as practically that of *Desmodium* in a state of standstill. We have seen that in these rhythmic animal and vegetable tissues the fundamental characteristics are identical :

- (1) In all of them stimulus gives either maximum response or none.
- (2) They all exhibit a long refractory period, during which additional stimulus produces apparently no effect.
- (3) They are all incapable of being tetanised.

And further, as regards the influence of various external agencies on the two classes of rhythmic tissues, animal and vegetable, the effects are also remarkably similar. Internal

A A

hydrostatic pressure renews in them rhythmic activity. All of them exhibit under certain circumstances similar cyclic groupings. The effects of chemical reagents are similar on both classes. Rise of temperature quickens the rhythm and reduces the amplitude of pulsation in a manner exactly similar in both ; and, finally, the effects of chemical reagents, even in the matter of antagonistic actions, are alike in the two classes. From a consideration of all these, it would appear that in studying response in rhythmic animal and vegetable tissues, we are dealing, not with two distinct but with a single class of phenomena. We are thus justified in ascribing the rhythmic action of the heart to those same causes which we have found to originate and maintain the rhythm of *Desmodium* or *Biophytum*. We have seen that these plants absorb energy continuously from the various forms of stimulus—mechanical, thermal, chemical, and other—to which they are subjected. This absorbed energy remains latent in the tissue, and determines its tonic condition, which is simply the sum total of these latent stimulating factors. When the sum of these factors exceeds a certain value, it will find expression outwardly in the form of excitatory discharges. This discharge, however, is not single and continuous, but intermittent. After each partial excitatory discharge, there is a diminution of conductivity and excitability which are only restored gradually. The long refractory period is merely an expression of this peculiar property. Owing to this periodic oscillation of conductivity and excitability, the *constant* latent stimulus finds expression in a rhythmic manner. Under favourable circumstances, there is a large surplus of accumulated energy, and long-continued responses, apparently automatic, are thus produced. Under less favourable conditions, when the stored-up energy is not great, a single stimulus gives rise to a single response, or, when the stimulus is stronger, to a multiple series of rhythmic responses ; and this statement is true of tissues exhibiting 'spontaneous movements,' not only in the case of the plant, but also in that of cardiac muscle.

It is impossible to conceive that there could be movement without an exciting cause. Automatism is said to be one of the properties of protoplasm. It will be seen, however, from the evidence which I have adduced in cases where experimental investigation is possible, that, strictly speaking, there is no such thing as automatism. Only under the action of a stimulus can a living tissue give responsive indications. The impact of an external stimulus may give rise to an immediate expression, or it may partly or wholly be reserved in latent form for subsequent manifestation. 'Inner stimuli' are simply external stimuli absorbed previously and held latent. An animal or a plant is thus an accumulator which is constantly storing up energy from external sources, and numerous manifestations of life—often periodic in their character—are but responsive expressions of energy which has been derived from external sources and held latent in the tissue.

SUMMARY

The rhythmic tissue of *Biophytum* may be regarded as equivalent to that of *Desmodium* in a state of standstill.

Both alike, when at standstill, give a single response to a single moderate stimulus, and multiple response to a strong stimulus.

Both, when the sum total of latent energy is above par, give apparently 'automatic' responses.

The rhythmic tissues of both plants exhibit a long refractory period.

The automatically responding leaflet of *Desmodium* is incapable of being tetanised.

An artificial increase of internal hydrostatic pressure renews pulsation in a *Desmodium* which was previously in a state of standstill.

The effect of rise of temperature on *Desmodium* is to produce a shortening of period and decrease of amplitude of oscillation.

The automatic responses of *Desmodium* often exhibit periodic groupings, of various degrees of complexity.

A A 2

Certain reagents tend to make irregular pulsations in *Desmodium* regular. Conversely, other reagents, like barium salts, induce irregularity in regular pulsations. The irregularity induced by the latter reagent may, however, be counteracted by a rise of temperature.

The effects of acids and alkalis on the pulsatory movements of *Desmodium* are antagonistic, acids inducing arrest of pulsation in a relaxed position, while alkalis induce its arrest in a contracted position. The standstill induced by one reagent may therefore be counteracted by the use of the other.

By all these, the rhythmic phenomena of the plant are seen to be identical with those of the animal.

The pulsation of the animal heart is thus to be ascribed to the same causes as bring about and maintain the rhythmic pulsations of *Desmodium*.

PART V
ASCENT OF SAP

CHAPTER XXVIII

SUCTIONAL RESPONSE AND ASCENT OF SAP

Inadequacy of existing theories of ascent of sap—General considerations regarding cellular activity and resultant propulsion of water—The Shoshungraph—Balanced Shoshungraph for determining variations of suction—Hydrostatic and Hydraulic Methods of Balance.

THERE are few phenomena in plant-life which have attracted keener interest and inquiry than that process of transport by which water is carried, from below the surface of the earth to the tops of the tallest trees. The obscurity of the subject is so great, and the secondary co-operating agencies so numerous, that the inquirer is apt to be led into the error of confining his attention to some one of them alone, imagining it to be the principal element in the problem. In studying this subject, then, our first effort must be to distinguish between the essential factor and others which are merely subsidiary.

For a statement of the inadequacy of these subsidiary factors to the solution of the problem, it is only necessary to refer to the summary of Strasburger and Pfeffer regarding existing theories of the ascent of sap :¹

The theory of *atmospheric pressure* is discredited, inasmuch as water is known to be lifted, in certain cases, to many times the height of the water-barometer.

The theory of *capillarity* is inadequate, inasmuch as continuous capillaries are absent, and the height to which liquids could be raised by such means would not, moreover, approach that of an ordinary tree.

¹ Pfeffer, *Physiology of Plants*, English translation, 1903, vol. i. p. 222, *et seq.* ; Strasburger, *Text-book of Botany*, English translation, 1903, p. 188.

The theory of *osmotic action* cannot be considered satisfactory, since such action is too slow ; besides which, there is no fixed distribution of osmotic substances, such as would account for the necessary transportation-current.

The theory of *root-pressure*, again, is open to the objection that it cannot possibly account for the maintenance of a sufficient force during the process of active transpiration, when root-pressure is found to be negative. Moreover, this root-pressure itself requires an explanation.

There is, however, another theory, due to Dixon, Joly, and Askenasy, which has apparently more to support it than any of those yet mentioned. According to this, the ascent is brought about by transpiration from the leaves. The fluid in the mesophyl cells of the leaves becomes concentrated by evaporation ; thus osmotic attraction is set up by the leaves, and the suction thereby exerted is supposed to be transmitted backwards, as far as the roots, through cohering columns of water. The difficulties in the way of this theory lie (1) in explaining how a slow osmotic action could produce so rapid a water-current ; (2) in the absence of any conclusive proof that, under actual conditions within the plant, the water-column could have sufficient tensile strength ; and, lastly, (3) in the fact which I shall demonstrate, that, when evaporation is not taking place in the leaves, the transport of water is still very considerable, and that, besides, other related phenomena, like exudation pressure, continue to take place even in the complete absence of evaporative activity in the leaves. I shall, moreover, be able to show that the movement of water often takes place in the plant in a direction opposite to that which would be the case if osmotic action were alone involved.

‘Thus,’ to quote Pfeffer, ‘a satisfactory explanation of the means by which the transpiration-current is maintained has not yet been brought forward. If no vital actions take part in it, then it is obvious that we have only an incomplete knowledge of the causes at work, and of the relationship of the different factors concerned.’¹

¹ Pfeffer, *Physiology of Plants*, English translation, 1903, p. 224.

There then remains the question as to whether living cells by some unknown physiological activity might not be instrumental in effecting this transport of water. But the experiments of Hartig, Bohm, and Strasburger have been held to contradict such a possibility. Thus, Strasburger set the cut ends of trees in tubs of poison, such as copper sulphate solution. The poison ascended to the leaves, a distance, in the tallest trees, of twenty-one metres. Now, if such violent protoplasmic poisons ascend the trunk, it is clear that they must kill all the cells lying in their path. That the living cells of the stems could not be necessary to the rise of sap was taken to be a necessary inference from this experiment. Strasburger also killed portions of the stems of living trees by heat, and yet the upper living and leafy portion was found to remain turgid for a few days. Another well-known experiment which was held to negative the theory of protoplasmic activity, was that in which boiling water was poured on the roots, when the plant continued to transpire, in spite of the roots having been killed.

From such considerations, Strasburger was led to conclude that 'the supposition that the living elements in any way co-operate in the ascent of the transpiration-current is absolutely precluded.'¹

I shall nevertheless show that the ascent of sap is fundamentally due to the physiological activity of living cells, and that the experiments described above in no way negative this, being, on the contrary, capable of a different, and very satisfactory, explanation. Many difficulties connected with the problem of the ascent of sap will be found to disappear, when the physiological activity of living tissues is once clearly established as the essential factor. But a vague assumption of protoplasmic activity will not be sufficient for the elucidation of the phenomenon. It will be necessary to show further how this excitatory activity is initiated, and by what means a definite-directioned flow is imparted to the sap.

¹ Strasburger, *Text-book of Botany*, English translation, 1903, p. 188.

We have seen in Chapter XXI. that when a strong stimulus is applied to the base of any organ, say a stem, a multiple series of excitatory waves is propagated onwards, such multiple responses being detected by electrotactile or electromotive pulsations. It was also shown in Chapter XXVI. that such multiple, passing into automatic, response, may be induced by the action of a constant stimulus. It was further demonstrated in Chapter XXI. that these excitatory waves, and the concomitant cell-to-cell contraction, would produce a movement of water forwards, along the direction of propagation. This series of excitatory waves, proceeding from the base of the organ, and propelling water forwards, must then cause a deficit of water behind. If, however, the base of the organ be kept supplied with water, this deficit will be made up by suction.

It is thus seen that by such rhythmic activity a one-directioned movement of water may be produced. Just as the various effects produced by multiple or autonomous response—in, for example, the electromotive and electrotactile responses, and in the multiple mechanical responses of *Desmodium*—give us an indication of the degree of rhythmic activity exhibited by the tissue, so, in the rate of this water-movement also, we have an additional means of measurement. This would be analogous to the measurement of the rhythmic activity of the heart by a determination of the rate of flow of the circulating blood. In the case of the plant this rate of movement may be measured, either by means of the propulsion of water forwards or by the suction exerted behind.

The ascent of sap in the plant, then, may be brought about by the rhythmic activity of the tissue. How this activity is initiated will be discussed later. Meanwhile it is clear that if the movement of sap be really an expression of protoplasmic activity, then any physiological modification which tends to increase that activity will also tend to increase the rate of movement; and *pari passu* any physiological condition which tends to depress the activity, will

correspondingly express itself in a diminished rate of movement. The movement of sap is thus taken to be another expression of that autonomous activity (multiple response) of the plant, which we have already seen exhibited locally by the motile tissue of *Desmodium*. The conclusive test of this would lie in proving that all those agencies which acted in a given way on the autonomous response of *Desmodium*, act also in the same way in modifying the rate of movement of sap. In other words, just as an exciting reagent will in the one case induce a greater amplitude, frequency, or both, of oscillation, above the normal, so in the other the excitatory nature of a given reagent may be expected to exhibit itself by an increase above the normal, in the rate of flow. A depressing reagent, on the contrary, should produce the opposite effect in both. That is to say, just as we may study the multiple or rhythmic excitability of a tissue through mechanical, electromotive, or electrotactile response, so here, in hydraulic response, or the determination of changes in the rate of flow of sap, we have an independent mode of investigating the same phenomenon.

The great difficulty of this investigation lies in the absence of a method by which these changes can be immediately recorded. In other words, we require some simple means of making a direct record, which will show, in a continuous manner, the changes produced by the various agencies, enabling us to distinguish their immediate effects, after effects, time-relations, and so on.

We have seen that the propulsion of water forward by the tissue is attended by a suction behind.¹ The quantity of water sucked up in a definite period will therefore give us an indication of the rate of movement of sap in the plant. Thus from the readings afforded by the water-index of a potometer, and the times at which such readings are taken, we may derive

¹ The forward movement of water, and the suction exerted, in the same tissue, are not necessarily equal in all cases. Part of the water sucked up may be deviated to increase the turgidity of the cells themselves. Suction may nevertheless be taken as a measure, other things being equal, of rhythmic activity.

the rate of movement. But these readings are necessarily discontinuous, and important phases of change are thus apt to be overlooked. They are, again, subject to error ; nor do they give us, at sight, the rate of flow, nor the changes in that rate, at any given moment. In order to determine such variations, a laborious process of construction of curves, from the experimental data, must, generally speaking, be undertaken.

It was therefore necessary to devise an apparatus by means of which curves might be obtained direct, so that a mere inspection would be sufficient to inform us as to the normal rate of suction, and the influence of external factors on that rate. This suction will be shown to be a physiological phenomenon ; its variation, therefore, will enable us to measure the physiological influence of various external agencies. It must be borne in mind that under ordinary conditions there is a normal rate of suction. The incidence of an external stimulus will change this rate, and the *variation* of rate which results is thus a measure of the effect produced by the stimulus. Similarly, we measure a force by noting the variation which it produces in the rate of movement of a uniformly moving body. The variation of the rate of suction may thus be taken as constituting a form of response to stimulus, which for the sake of simplicity we shall designate as *Suctional Response*.

The Shoshungraph.—For the purpose of subjecting the plant to various conditions, and also in order to obtain the record of the resultant suctional response, I have constructed an apparatus to which I have given the name of the *Shoshungraph*.¹ It consists of (1) an arrangement by which the specimen may be rapidly subjected to the action of different excitatory or depressing agents ; (2) a potometric tube, by which the constant changes of suctional activity are measured ; (3) a contrivance by means of which the movements of the water-index, with their time-relations, are recorded. The principal parts of this instrument are shown diagrammatically in fig. 156. *v* is the plant-vessel, in which

¹ From Sanskrit, *Shoshun* = suction.

the specimen is mounted by means of a water-tight india-rubber cork. The vessel is closed at the bottom also by means of a large cork through which enter four tubes. One of these, controlled by the stop-cock A, is connected with the capillary potometer-tube. The second, controlled by A', leads to the compensating vessel C, filled with water. The interior ends of these two tubes reach almost to the top of the plant-vessel. The third, with stop-cock B', leads to

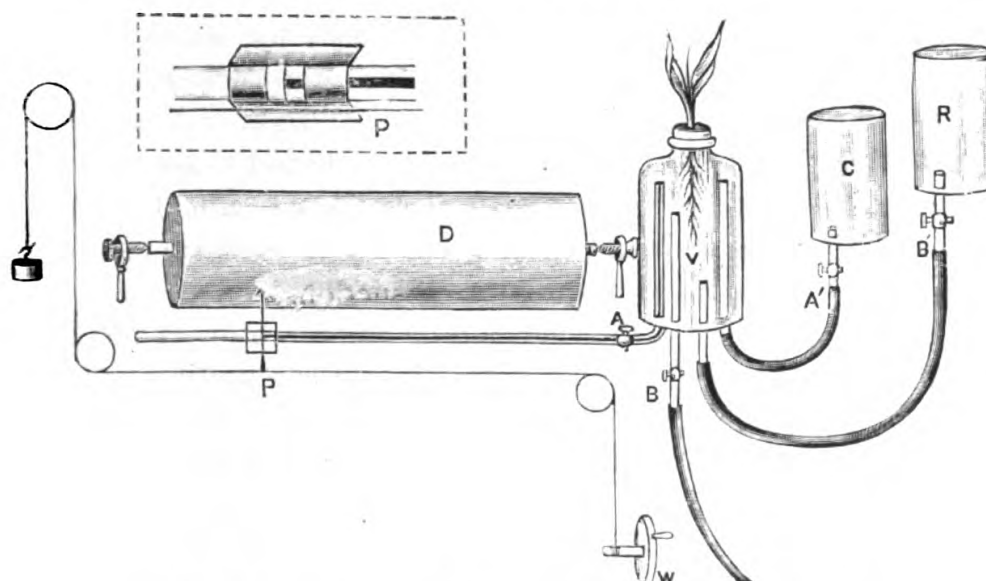

FIG. 156. Diagrammatic Representation of the Shoshungraph

v, plant-vessel; C, compensator; R, reservoir. The potometer-tube is controlled by stop-cock, A; compensator by A'; and reservoir by B'. B is the stop-cock of the outflow pipe; D, recording drum driven by clockwork; P, collar carrying recording pen, seen magnified above. The water-index is followed by appropriate manipulation of the wheel, w.

the reservoir R, from which water at various temperatures or different chemical reagents may be introduced. The fourth is an outlet-tube controlled by the stop-cock B.

Adjustment for Unbalanced Record. — The great difficulty in connection with delicate experiments arises from the presence of air-bubbles in the plant-vessel, which are not easy to expel. This is done, however, by means of an escape-tube, with a stop-cock, which runs through the upper cork,

and is not shown in the figure. The stop-cock A' is opened, A, B, and B' being closed. Water from the compensator C thus passes into the plant-vessel, and the air-bubbles which have been accumulating at the top of the vessel escape, with the water which is driven out at the escape-tube. When all are expelled then the stop-cock of the escape-tube, and A', are closed. The potometer stop-cock A is now opened, and the water-index is adjusted at any point desired, by manipulation of the stop-cocks B and A'. A temporary opening of the stop-cock A' of the compensator C causes the water-index to move to the left ; whereas, when the stop-cock B, of the outflow pipe, is opened, it moves to the right. After this preliminary adjustment the stop-cocks A', B, and B' are closed, the potometer tap A being kept open ; the movement of the water-index per unit-time now gives us the normal rate of suction of the specimen.

We come next to the question of making a direct record of the rate of movement. For this purpose, a writing pen is fitted on the potometric tube, by means of a brass collar. This brass collar has a rectangular opening, which enables us to watch the water-index. It has also stretched across it a fine wire, which is kept always coincident with the water-index. This wire is parallel with, and placed vertically above, the recording pen. The collar is attached to a thread which passes round small pulleys. One end of this thread carries a counterpoise and the other is wound round a wheel, W, which can be so manipulated as to make the index-wire follow the movements of the water-column. When the wheel is wound, the index moves to the right ; when it is slightly released, the weight of the counterpoise makes it move to the left. The weighted recording pen rests with its point on a revolving drum, D, covered with paper for the record ; this drum is kept revolving by clockwork at a known and adjustable speed. When the water-index is followed in the way described, there is produced a direct record of water-movement in the plant. A curve is thus traced, the ordinate of which represents the quantity of water sucked up, and the

abscissa the time. The slope of the curve thus gives the rate of movement. As long as the suction is uniform, the slope remains constant. If any exciting agency increases the rate of suction, there is an immediate flexure in the curve, which thus becomes steeper. A depressing agent lessens the slope of the curve. And when suction is abolished, the record becomes horizontal.

By this arrangement, then, we are enabled, simply and accurately, to obtain a direct and continuous record ; and as the necessity for taking readings is obviated, a large number of experiments can be performed very quickly, with little trouble. The flexure in the curve affords immediate visible indication of the effect of any particular agency. The value of each division of the ordinate is found once for all by determining the volume of unit-length of the potometer-tube. A previous determination at the beginning of the experiment of the rate of movement of the drum, gives us the time-value of each division of the abscissa. Knowing these, we can determine the absolute rate of suction at any period of the curve required. Responsive variations of suction are more easily detected when the normal curve is almost equally inclined to the ordinate and abscissa—that is to say, when it makes an angle of about 45° with either. This is most easily accomplished if we keep the potometer-tube always the same, and merely adjust the speed of the drum.

The Balanced Shoshungraph.—According to the simple method of making records which has just been described, we observe the responsive effect by means of flexures produced in the curve under the action of various agencies. If the effect of an agency be slight, the change in the slope of the curve will be proportionately small and liable to escape detection. In order to bring the sensitiveness of the instrument to its highest, I have devised the Method of Balance, by which the slightest responsive variation is made to exhibit itself in a marked manner. For the purpose of many delicate investigations, it is not so necessary to know the normal rate of suction, as the *variations* positive and negative in that rate.

An agency which induces the positive variation will then be excitatory, while that which induces the negative is depressing. In order to carry out my investigations along these lines, I have employed two different methods of balance. In one—the Hydrostatic Method of Balance—the natural suction of the plant is arrested by a counter-hydrostatic pressure suitably applied. The effect of an external agent is now studied by the direction, positive or negative, and the extent to which it disturbs the static equilibrium thus established. Experiments carried out on this method will be described in the next chapter.

The second—or Hydraulic Method of Balance—depends upon an application of compensation, by means of which under normal conditions the water-index is kept stationary, though the suctional movement in the plant is in no way disturbed. According to this hydraulic method, the normal rate of suction, when balanced, gives rise to a neutral, or horizontal, line in the record; while an exciting agent produces an inclination upwards; and a depressing agent a declination downwards. The balance, by which under normal conditions the neutral line is secured, is obtained by allowing water to enter the plant-vessel from the compensator C at a rate exactly equal to that of its withdrawal by suction.

In practice, this adjustment is roughly made by opening the stop-cock A' in connection with C, to a greater or less extent. Over-balance causes movement of the water-index to the left; under-balance to the right; and when the adjustment is perfect, the water-index becomes stationary. After making the preliminary adjustment, the final balance may be obtained, by very careful and gradual movement of the compensating reservoir up or down. When the reservoir is raised the flow is increased, owing to the greater difference of level established, as between the reservoir and the plant-vessel. The stand on which the vessel C is placed is provided with a rack and pinion, by means of which the necessary adjustment of height is made.

Introduction of changed conditions.—We have thus

seen how the normal rate of suction and its variations may be recorded accurately. The next difficulty to be overcome is that of introducing the changed conditions without creating any disturbance, thus practically maintaining the continuity of record. It will be necessary to observe, among other things, the immediate and after-effects of cold and heat, as well as those of various chemical reagents. This is accomplished by the right manipulation of the four stop-cocks. Let it be supposed that we wish to study the immediate and after-effects of cold. Up to this time the stop-cocks A and A' have been opened—B and B' being closed—and the balanced horizontal record taken. For the sake of simplicity I refer to the stop-cock A' as the only one which opens and closes the communication with the compensator C. In reality, however, there is a second stop-cock in its neighbourhood, by which the balancing adjustment is first made, A' being employed for opening or closing communication under such an adjustment. The reservoir R is now filled with cold water; A and A' are next closed—thus arresting the water-index—and B and B' opened. The water then leaves the plant-vessel by the overflow pipe, and its place is taken by cold water from R. After this, the stop-cocks B and B' are once more closed, and A and A' opened. The index, being now released, indicates by its movement the excitatory or depressing effect of cold. It must be remembered that the index was previously adjusted to balance. Should the effect of cold prove to be excitatory, the rate of suction would be increased; under-balanced by the supply of water from C, the index would move to the right, thus giving positive response. If, on the contrary, the effect should be depressing, the rate of suction would be decreased, and the water from the compensator would produce an over-balance, causing a movement of the index to the left, or negative response. By now filling the reservoir R with water at the ordinary temperature, and repeating the operation, the original condition is re-established, and the effect of re-establishment of old conditions observed. In a similar manner,

B B

we may study the immediate and after-effects of rise of temperature, and of the various chemical reagents.

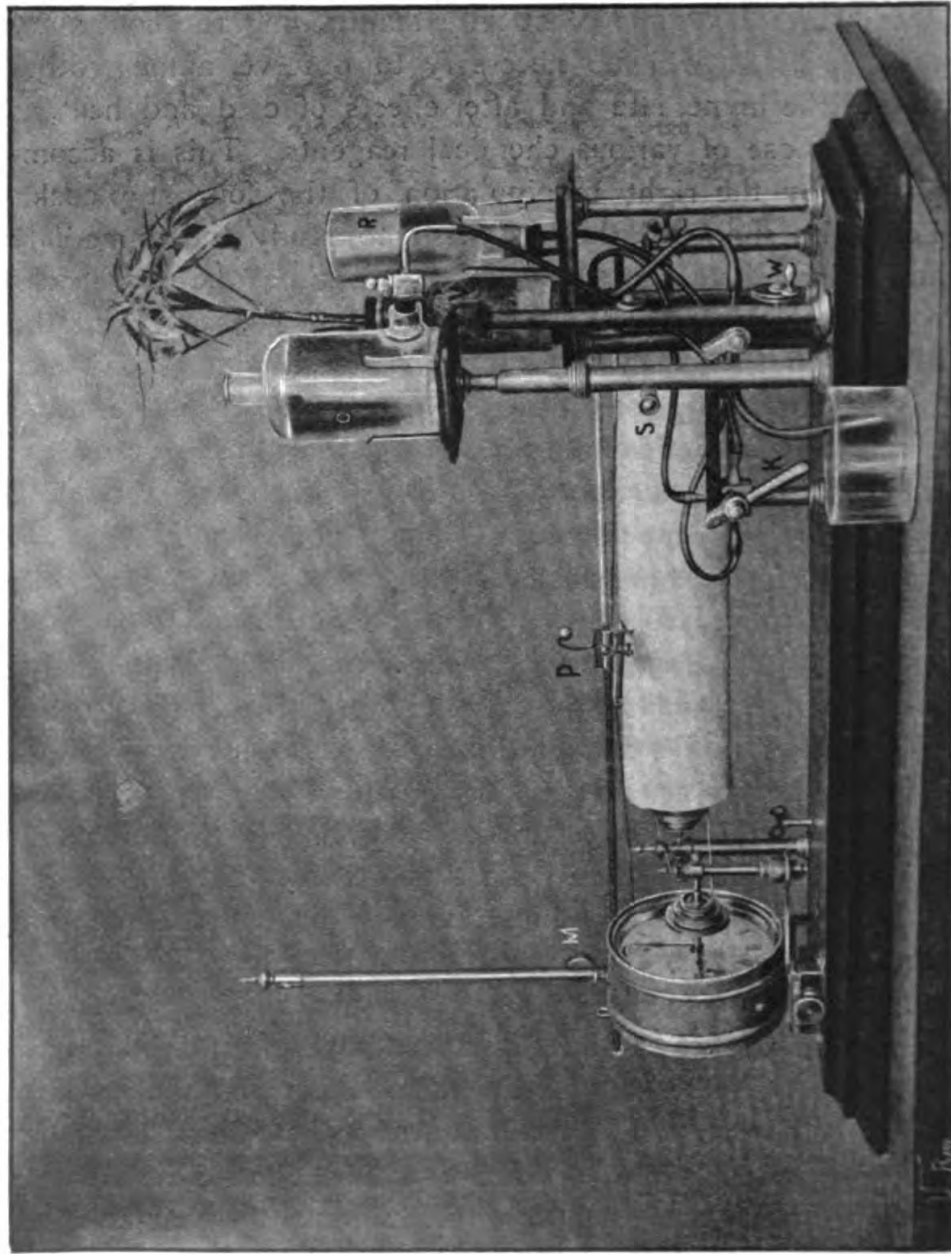

FIG. 157. Photograph of Shoshungraph

V, plant-vessel ; R, reservoir ; C, compensator, whose balancing height is adjusted by rack and pinion, S ; K, key for manipulation of four-way stop-cock ; P, recording pen, [with counterpoise M, manipulated by wheel, W. The drum is rotated by the clock at uniform speed.

In order to make the explanation easier, I have described all these stop-cocks and their serial opening and closing separately ; but this arrangement, apart from its clumsiness, would involve a certain loss of time. In many of these experiments, it must be remembered, it is necessary to know the immediate effect produced. I have therefore simplified the procedure by the use of a special key, K, by turning which, in one direction or another, the requisite alternate openings and closings are accomplished.

Thus, on turning the key-handle to the left, A and A' are opened, and B and B' closed. The balanced record is now taken. As the handle is now being turned to the right, the stop-cocks A and A' are first closed, arresting the index. Continued turning to the right opens B and B', by which the modifying reagent is introduced into the plant-vessel. A sudden turning of the key to the left now closes B and B', and opens A and A', thus releasing the index and enabling the record to be taken once more, under the changed conditions. The whole process is thus made so rapid, that modified conditions can be established, and the record renewed, within the short interval of less than one minute. The photograph of the completed apparatus is seen in fig. 157. Having now given in detail all the experimental arrangements, I shall in the next chapter describe the physiological modifications induced by different agencies, as exhibited by the suctional response. The periodic variation of ascent of sap may be recorded continuously and automatically by photography. Another method of recording transpiration will also be found described on page 472.

SUMMARY

This chapter gives a description of the Shoshungraph, by means of which the rate of suction and its variations may be indicated and recorded. The sensitiveness of the apparatus is very much increased by the Hydrostatic and Hydraulic Methods of Balance.

B B 2

CHAPTER XXIX

MODIFICATION OF SUCTIONAL RESPONSE

Effect of temperature on suction by three methods of inquiry : (1) Unbalanced method of Shoshungraph : (a) Action of cold—(b) Action of moderate rise of temperature—(2) Method of Hydrostatic Balance : (a) Action of cold—Reversal of normal direction of flow—(b) Action of warm water—(3) Method of Hydraulic Balance : (a) Action of cold—(b) Effect of warm water—Explanation of suction when the root is killed by boiling water—Stimulation renews suctional activity in plant whose suction has come to a standstill—Osmotic *versus* excitatory action—Abolition of suction by poison—Suctional activity continued until whole plant is killed by poison.

I SHALL now proceed to prove that the movement of water in plants is mainly due to rhythmic excitation of the tissue, and that evaporation from the leaves, osmotic action, and so on, are only co-operating factors, of subsidiary importance. We have seen in Chapter XXI. that any part of a stem when excited will become the seat of rhythmic activity, and that this pulsatory excitation causes movement of water. I shall now demonstrate a similar phenomenon by means of suctional response, eliminating from some of the typical experiments all auxiliary factors, such as osmotic action and evaporation from leaves. I have shown in the last chapter how the effect of suctional activity may be continuously recorded by means of the Shoshungraph. We saw also that the effects of various agents, exciting or depressing, were to be detected, under the unbalanced method, by appropriate variation in the slope of the curve. By the balanced method, whether hydrostatic or hydraulic, the derangement of the balance upwards indicates an increase of activity, and its derangement downwards a decrease. I shall first demonstrate the fact that these observations, though obtained by such various methods, are all reliable and mutually consis-

tent, by subjecting the plant to the action of an agent whose general effect is well known, and recording the results by all three methods. For this purpose we shall take the influence of low and moderately high temperatures.

Modification of suctional response by various agencies.

We have seen that any sudden variation of temperature acts as a stimulus in itself. Thus, if we touch the pulvinus of *Mimosa* or *Biophytum* with ice, there is a responsive twitch. This may be taken as the preliminary effect. Prolonged application of cold, however, abolishes excitability. If the ascent of sap be really a phenomenon of excitation, we may expect to find a sudden application of cold, appropriately made, producing a preliminary augmentation, followed by the depression and arrest of suction. An application of hot water might be expected, on the other hand, to bring about the contrary effect, that is to say, an increase in the rate of suction. I shall now describe the experimental results obtained by the three methods.

Effect of temperature on suction: (1) Unbalanced Method. (a) *Action of cold.*—As I did not know what might be the effect of injury on the suctional activity of the plant, I selected intact specimens for my first experiments. For this purpose I took cuttings of *Croton*, a plant whose stem when placed in water will develop roots in a few weeks' time. When the roots were well developed, the specimen was fitted in its place in the apparatus. In other cases, I took pot-grown specimens and placed them in water, so that the earth was dissolved away. Violence to the rootlets was thus avoided. I may here state, however, that I found, in the course of these experiments, that there is no essential difference between the effects exhibited in such intact plants and those observed in the case of cut branches. All that is necessary in the latter case is that the specimen should be mounted in the apparatus and left for some time, in order that the effect of the disturbance caused by cut may pass. The record afforded by a specimen thus mounted gives the normal rate of suction. The attainment of constancy of

external conditions is gauged by the uniform inclination to the curve, and it may be well to mention here that throughout the investigation every experiment was begun with this test.

The normal rate of suction, in the first experiment, in a *Croton* at the temperature of the room (23° C.), was eight cubic mm. per minute. On now applying cold water at a temperature of 4° C. to the root, by appropriate manipulation of the stop-cock, the rate showed the preliminary excitatory effect, due to sudden variation of temperature, by an increased

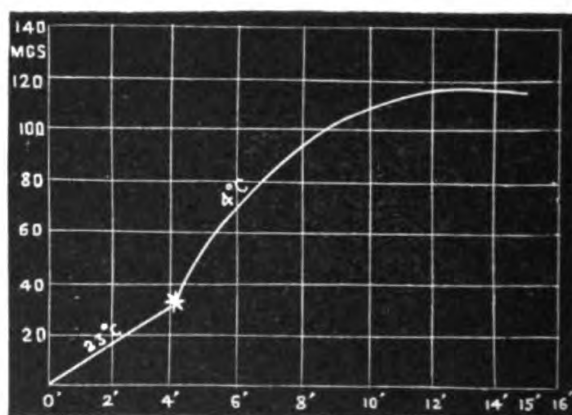

FIG. 158. Effect of Cold on Suction

The first part of the record shows the normal rate of suction at 23° C. Asterisk marks moment of application of cold water at 4° C., which is seen to produce a preliminary exaltation, followed by arrest of suction. Abscissa represents time in minutes; ordinate, the quantity of water sucked up in milligrammes or cubic mm.

rate during the first two minutes, of eighteen cubic mm. per minute, or 2.25 times the normal value. But this temporary exaltation gradually passed away, till there was an almost complete arrest, ten minutes after the first application (fig. 158). This arrest by cold was not found to be permanent; for it disappeared on the return to a higher temperature, as will be seen in the first part of the next figure (fig. 159), which was taken after water at 23° C. had been substituted for the cold water in the vessel. In this second curve, the rate of suction is found to return almost to the normal

degree, being now about seven instead of eight cubic mm. per minute.

(b) *Action of moderate rise of temperature.*—I next tried the effect of a rise of temperature. This experiment was performed with the same specimen as the last, in which the return normal rate of suction at 23° C. had already been determined to be seven cubic mm. per minute. On now

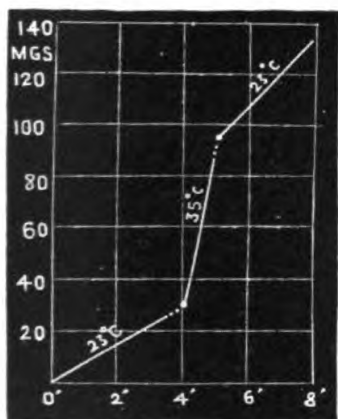

FIG. 159. Curve showing Normal Suction at 23° C., Increased Suction at 35° C., and the After-effect persisting on Return to Normal Temperature

This experiment was carried out on the same specimen as the last.

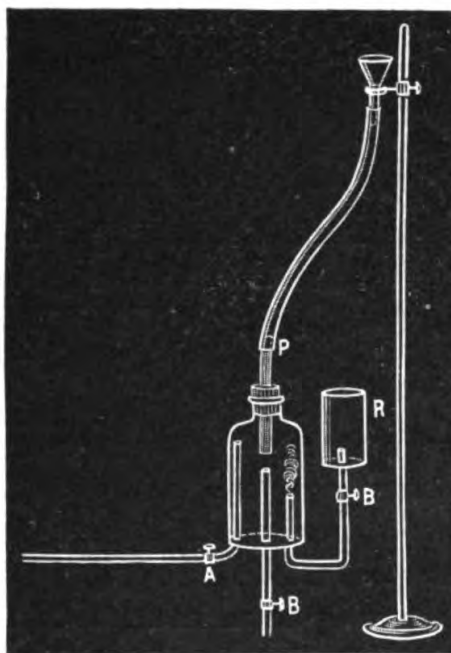

FIG. 160. Method of Hydrostatic Balance

A short length of stem, P, has its ascensional water-movement balanced by superincumbent water-column of variable height.

applying water at 35° C. it will be seen that a very steep rise was induced in the curve, indicating an increased suctional rate of fifty-eight cubic mm. per minute, more than eight times the rate at 23° C. On now once more substituting water at 23° C. the rate became lowered, though not to the original degree (fig. 159). It must be remembered, with regard to this, that the movement of sap depends on the cell-activity of the entire plant, and that the tissue has by this

time absorbed some quantity of hot water, which cannot immediately be displaced by the water of ordinary temperature which is applied at the roots. The rate of suction, therefore, could not at once revert to the normal, but must be expected for some short period to show a slight enhancement. The curve shows that on the return to 23° C. the rate fell from fifty-eight to fourteen instead of to the original eight cubic mm. per minute.

(2) **Method of Hydrostatic Balance:** (a) *Action of cold.*—For this experiment I took a *Croton* stem cut at both ends, the lower end being placed in the plant-vessel of the apparatus. There was now found to be a considerable movement of water upwards. This movement was arrested by suitable hydrostatic pressure, the upper end of the stem being connected with an india-rubber tubing filled with water and ending in a funnel (fig. 160). To prevent evaporation, the surface of the water in the funnel was covered with a thin film of oil. Rather a high hydrostatic pressure was required to produce a balance. When the pressure of a column of 75 cm. was applied, there was still a movement of water upwards in the tissue, at so great a rate as ten cubic mm. per minute.

In this experiment, then, the root having been cut off, there is still a considerable propulsion of water upwards through the stem. It is thus clear that root-pressure is not the essential factor in the ascent of sap. As the leaves had also been cut off, and the cut end of the stem covered by water sealed with a film of oil, evaporation from the leaves, and the osmotic action thereby produced, are also seen to be excluded. These, like root-pressure, therefore, cannot constitute the essential factors in the process of suction. But since, on the contrary, any small length of the stem is competent to show this water-movement, the required activity must reside in the tissue of the stem.

A balance was finally obtained, by the pressure of a water-column of 105 cm. This equilibrium is not to be regarded as merely the result of equality between the upward

pressure, exerted by suction from below, and the downward pressure of the superincumbent water-column. There are reasons for thinking that there may also be an important additional factor, of opposed rhythmic activities, balancing each other. For when a cut branch is placed in water, the lower end becomes over-turgid, and this, as we know, is a condition for the initiation of rhythmic activity. The upper end of the branch not being so turgid, activity will be greater below than above. We therefore obtain a movement of water from the more to the less active. But if the leafy end of the branch be immersed in water, and the cut end held in the air, it is known that the direction of the flow becomes reversed. This is evidently due to the fact that it is now the upper end which is over-turgid, and therefore relatively the more active. Similarly, in the case of the balance described, the activity of the lower end, which determines the flow upwards, was opposed and balanced by the increased activity of the upper half, induced by increased hydrostatic pressure.¹ The experiment which I am about to describe, besides demonstrating the effects of cold and warmth, also lends strong support to the view that the direction of the resultant movement of sap is determined by the relative activities of the two ends of the stem.

When the balance had been obtained, as already described, with a pressure of water of 105 cm., the record on the drum became horizontal, as has been explained. Cold water was now applied to the specimen at its lower end. As sudden cooling constitutes a stimulus, while its continued action produces depression, we should expect a transient augmentation of the activity of the lower end of the specimen, followed by its diminution and arrest. The record should therefore show a preliminary movement of water upwards, followed by the reversal of the current, which should now, as the permanent effect of cold applied below, be from the

¹ Rhythmic activity is, in general, increased by an increase in the hydrostatic pressure. But there is a limit to this. Excessive pressure, above a certain critical point, is found to depress rhythmic activity (p. 350).

more active upper, to the less active lower end, or downwards. The record will be seen to verify this anticipation in every particular (fig. 161). Cold water was applied below—represented by \times in the record—which before application was horizontal. After this we observe a movement of water upwards, at a rate of four cubic mm. per minute. The upward flow continues for about seven minutes, by which time the

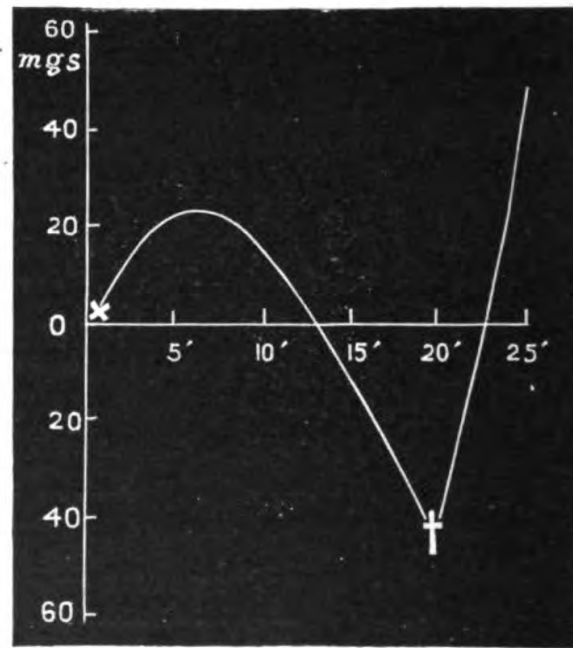

FIG. 161. Record obtained by Method of Hydrostatic Balance of Successive Applications of Cold and Warm Water

After obtaining static balance, with horizontal record not shown in the figure, cold water was applied below at moment \times . The transitory excitation thus occasioned causes movement of water upwards, followed by depression and reversal of flow downwards. Warm water next applied at \dagger causes second reversal and flow of water upwards.

activity of the lower end of the specimen has become so depressed as to cause reversal of the flow, which is now from above downwards at an average rate of about six cubic mm. per minute. This record was taken continuously for some time, when hot water was quickly substituted for cold, in the plant-vessel. A cross marks this point in the record.

(b) *Action of warm water.*—The result was not only that

its sluggishness was now obviated, but that the lower end of the specimen was actually rendered the more excitable of the two, and we observe a second reversal of the direction of current, which now flows upwards.

(3) **Method of Hydraulic Balance.**—This Hydraulic Method of Balance is much easier to carry out than the arrest of movement by hydrostatic pressure. It does not, moreover, in any way interfere with the normal movement of water through the plant. For the balance is obtained and the index rendered stationary, by the simple device already explained, of allowing a subsidiary flow of water to enter the plant-vessel, at a rate exactly sufficient to compensate for the loss by ascent of sap.

(a) *Action of cold.*—This experiment was performed on a leafy branch of *Croton*. The balanced horizontal record was first taken at 22° C., after which ice-cold water was passed into the vessel. A record was made of the immediate or preliminary excitatory effect of this cold water on the rate of suction, and continued during the return of the water to the temperature of the room. In this record, then, we shall find, besides the immediate, the continued effect of cold, and subsequently the effect of gradual restoration to an ordinary temperature. In the present record (fig. 162) we see the transient and permanent effects of cold exhibited as before. According to the method of Hydraulic Balance, as has been explained, an ascending line in the record means a positive variation, or increase of the rate of suction over the normal. A descending line, on the contrary, denotes a negative variation, or diminution of the rate of suction below the normal. And a horizontal line shows return to the original rate. In the first, or upper, of the two curves in fig. 162, the immediate effect of cold is seen in a very marked positive variation. After the lapse of about five minutes, the effect of continued cold is seen in the depression, which shows itself by the reversal of the curve. This depression continues, till the temperature of the vessel has returned to that of the room, which takes place in the course of about forty minutes.

The normal rate of suction is now re-established, as seen in the fact that the record becomes horizontal.

(b) *Effect of warm water.*—I next tried the effect on the same specimen of water at a higher temperature, falling by degrees to the temperature of the room. We should expect in such a case, to obtain the excitatory effect of rise of temperature, with subsequent approach to the normal, without any reversal, indicative of the transition from exaltation to depression, such as was observed in the case of application of cold. From the second and lower of the two curves

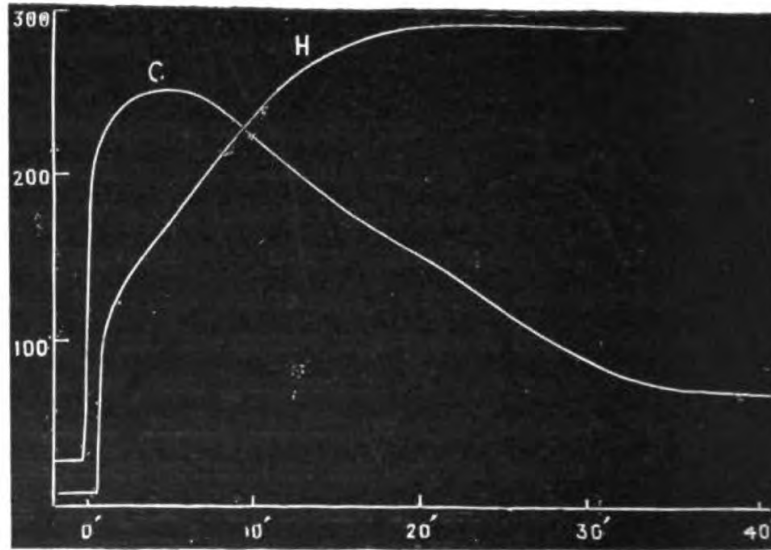

FIG. 162. Record, obtained by Method of Hydraulic Balance, of Successive Effects of Cold and Warm Water

shown in fig. 162, it will be seen that this is the case. The curve at first rises abruptly, and it continues to rise, though with decreased speed, till, when the temperature of the vessel is once more normal, it becomes horizontal, indicating the resumption of the original rate of suction.

We have thus seen, by three different methods of inquiry—those namely of the Unbalanced Shoshungraph, the Hydrostatic Balance, and the Hydraulic Balance—that the records, though of different forms, exhibit effects of which the interpretations are identical. For delicate experiments, the

Hydraulic Method of Balance will be found most sensitive : for ordinary purposes, however, the unbalanced Shoshun-graph is simple and efficient ; and in the investigations which follow I shall use this method only.

Explanation of suction, when the root is killed by boiling water.—I shall now take up the apparently anomalous case in which, when the root has been killed, by pouring boiling water over it, the suction of the plant is nevertheless maintained. In such an experiment, the normal record was first taken, and on allowing boiling water to enter the plant-chamber there was a steep rise in the record, showing the excitatory action due to the application of hot water. The boiling water was now passed in continuously for several minutes, so as to ensure the killing of that portion of the plant which was immersed in the vessel. On allowing the water in the vessel to return to the temperature of the room, it was found that suction continued, at an even greater than the original normal rate.

This result would at first appear to show that protoplasmic activity had nothing to do with the ascent of sap. And the objection would have been fatal, if the rhythmic activity which produces suction had been confined to the roots alone. But such activity is present to a greater or less extent throughout every zone of the plant, and it is by the combined action of all these that the ascensional movement is maintained (p. 376). Thus, when hot water is poured on the root, its first effect is a sudden increase of the activity of that organ, by which warm water is carried to the higher zones, there as a stimulating agency to increase this rhythmic activity. It must be remembered that on reaching the stem above the vessel, the hot water itself is considerably cooled. Hence the only portion of the plant which is killed is that which is actually immersed in the boiling water, or in immediate contiguity with it. The unkilld portions above continue their suctional activity unabated.

I have said that the suction, on the return of the water to its old temperature, continued to take place at a greater

than the original rate. This was due to the fact that, instead of the extremely attenuated channels of the root-hairs, through which suction normally takes place, there was now substituted the whole mass of the root, acting virtually as a wet rag, tied round the base of the living stem; and indeed it was found that, whereas the stem outside the vessel was turgid, the portion within was limp and soft. The mass of water which it was thus possible to suck up directly, by means of the broad-sectioned stem, was evidently much greater than could have been the case through the intervention of the resistant organically conducting channels of the rootlets.

We must not forget the obvious fact that a plant is a colony of more or less independent living cells, each of which maintains its physiological activity as an individual. The death of one group does not necessarily, therefore, arrest the physiological activity of its neighbours. The plant is finally killed only when every one of its cellular elements has undergone death.

Further proof that suction is an excitatory response.—

We have seen in the case of rhythmic *Desmodium*, when it is kept for a long time under unfavourable circumstances, that its activity comes to a stop owing to the run-down of stored-up energy. We also saw how the application of thermal stimulus would re-initiate this activity. Again, if we keep a cut branch of any plant in water, after a few days its suctional activity, as is well known, disappears. This abolition of suction is attributed to the blocking of the cut end by mucilage and bacterial growths, and the making of a fresh section is found to renew the activity.

But, though the blocking of the cut end of the stem by outgrowths does, no doubt, obstruct the passage of water, yet the total abolition of suction may not be due to this cause alone. It may be induced, in part at least, by depression of the rhythmic activity of the tissue, owing to the run-down of its latent energy. The making of a fresh section does not decide this question, for, in doing this, we apply

the strong mechanical stimulus of a cut. I therefore devised an experiment which appears to show that this run-down of energy does in such a case constitute a factor in the abolition of suction. Without in any way disturbing the mucilaginous end of the stem, which had ceased to exhibit its suctional activity, I supplied it with water somewhat above the ordinary temperature. This thermal stimulation at once initiated renewed suctional activity with great vigour, just as its rhythmic mechanical activity was renewed by *Desmodium* on the application of similar stimulus.

Osmotic versus excitatory action.—Though, under the co-operation of a favourable disposition of osmotic substances, the suctional activity of the tissue may be increased, yet I have shown that suction is normally maintained even without the co-operation of this factor (p. 376). I shall now proceed to show that this suction may increase even in opposition to osmotic action. And such a demonstration will further prove the excitatory physiological nature of the processes which bring about the ascent of sap. Among various solutions of salt, some are physiologically neutral in their effects; ¹ of these, potassium nitrate may be taken as an example. Others, again, like strong solutions of sodium chloride, act as excitatory agents. The application of this last reagent is known to initiate rhythmic excitation in animal tissues. Similar effects have been shown to be brought about by this reagent, in the case of *Biophytum* and *Desmodium*.

Thus, in a strong solution of potassium nitrate, we have a reagent whose physiological action is more or less neutral while its osmotic action is pronounced, and in a strong solution of common salt we have an agent which is both excitatory and osmotic at the same time. If, then, we apply KNO_3 solution to the base of a cut stem, placed in the Shoshungraph, water will be osmotically withdrawn from the plant, in opposition to normal suction, and the

¹ It should, however, be remembered that solutions, even of inactive salts, above a certain strength, will induce physiological depression, and thus bring about diminution of transpiration.

normal suctional rate will be somewhat reduced. This is seen in the accompanying record (fig. 163), which I obtained with a cut branch of *Croton*. The normal rate of suction was in this case twenty-six cubic mm. per minute. After the application of potassium nitrate solution this was found to be reduced to seventeen cubic mm. per minute. But if, instead of this, we apply strong solution of sodium chloride, two antagonistic effects will be produced. One, due to

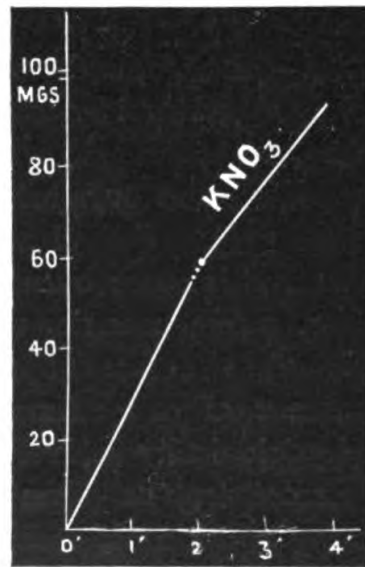

FIG. 163. Effect of Strong KNO_3 Solution

The first record shows the normal and the second the depressed rate of suction caused by the reagent.

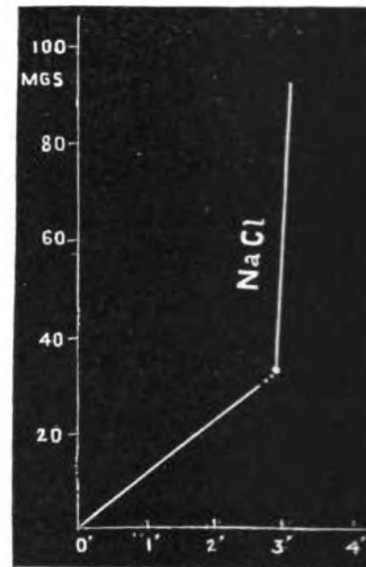

FIG. 164. Effect of Strong $NaCl$ Solution

The first record shows the normal and the second the exalted rate of suction caused by the reagent.

osmotic action, will oppose suction; and the other, due to the excitatory nature of the reagent, will accelerate suction. The resultant effect will, then, be modified by the excitability of the experimental plant itself. In some cases we should expect to find the excitatory reaction predominant, and in others the osmotic. In repeating the experiment, on different specimens of *Croton*, I have found these theoretical inferences to be fully verified. As the more interesting of the two cases, I give a record (fig. 164) in

which the excitatory effect is shown by the very great increase in the rate of suction induced after the application of the reagent. We have here a very great enhancement of the ascensional movement of water in spite of the osmotic attraction of the solution, which alone would have retarded the normal rate.

The action of poisonous reagents.—In studying the effect of poison on the rhythmic activity of *Desmodium*, we found that this was modified by the tonic condition of the plant. Thus a vigorous specimen was shown to be much less affected by poison than one which was weakly. Certain poisons, again, act more quickly than others in inducing the death of the plant. We have also seen, in that experiment in which the root was killed with hot water, that upper and unkilld portions of a specimen will continue to exhibit suctional activity when lower parts are killed ; and also that, in general, the killed area offers no barrier to the passage of water through its dead tissues.

That a poison can easily pass through killed tissues, owing to the suctional activity of cells higher up, we have seen in our experiments on *Desmodium*, when the cut end of the petiole was placed in copper sulphate solution (p. 326). It is fortunate that in this case, during the ascent of poison, we have areas, the activity of which is indicated visibly by the rhythmic motile indications of the pulvini of the inserted lateral leaflets. That copper sulphate solution arrests rhythmic activity and induces death, is seen by the rapid stoppage of pulsation, when we apply it directly on the pulvini of the pulsating leaflets. When it is applied, however, at the cut end of the petiole, the arrest of pulsation takes place much later, this delay being due to the time taken for the poison to ascend through the intervening distance. This shows clearly that successive zones are killed one after another, and that the death of a point below does not stop the suction above. From this experiment it is evident that the application of poison at the root, or the cut end of a stem, does not in general arrest

C C

suction, until the whole plant is killed. And from the Shoshungraphic records we find that the final arrest occurs after an appropriately long period.

In this connection, I shall describe some very interesting results of rapid arrest of suction, which I have often obtained by the action of poison. I was already familiar with a fact which I had come across while studying the effects of various chemical reagents on the longitudinal response of radial organs namely, that death was attended in such cases either by an abnormal contraction or by an abnormal relaxation. These two effects were liable, again, to be modified by the

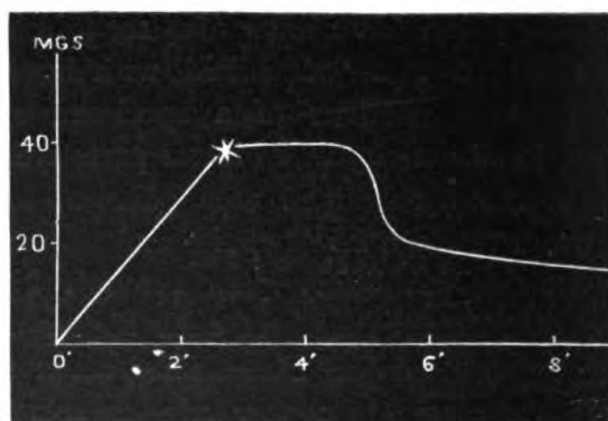

FIG. 165. Effect of Copper Sulphate Solution

The first part of the record shows the normal rate of suction. The asterisk denotes the time of application of the poisonous reagent.

tonic condition of the tissue. In now studying the effect of solution of copper sulphate on the suctional activity of *Croton*, I noticed certain peculiarities in the record, which appeared to be related to the results just described. These peculiarities, it should be mentioned, were specially noticeable in those specimens which were experimented on during the month of April, that is to say, at the end of the Indian spring.

In a particular experiment the normal suctional rate had been fifteen cubic mm. per minute. On the application of copper sulphate, the suctional movement was quickly

arrested, and this was followed almost immediately by a slight movement in the negative direction, showing that, by some spasmodic contraction, water was being expelled from the tissue. This phase was succeeded by an almost complete arrest of suction, there being now only the feeblest ascensional movement (fig. 165). Within a short period after this, on washing off the poisonous reagent, it was found that the arrest had been temporary only, suction being renewed at the rate of eleven, instead of the normal fifteen, cubic mm. per minute.

I applied the poison once more, and allowed it to act for thirty-six hours. The arrest was then found to be permanent—that is to say, the substitution of fresh water induced no revival of response, the plant being killed throughout.

Strasburger, as we have seen, in his experiments on the effect of poisonous reagents on plants, found that the reagent is carried to the top of the tallest tree; from this fact it was inferred that since all the cells in the path of the poisonous solution must necessarily be killed by its action, therefore the activity of living cells was not the essential factor in the ascent of sap. But I have proved that the ascent of sap is brought about, not by any localised group of cells in a particular region, but by cells which extend throughout the length of the plant. Even after some of these have died, therefore, by the access of poison, those above are still active, and will continue to exhibit suction till they in their turn are finally killed. It will thus be evident that the movement of ascent cannot be completely abolished till the poison has effectively reached the very top. As all the living cells are actively concerned in the work of suction, this conveyance of poison to the top of the plant is what was to be expected. Only after such conveyance, indeed, could permanent arrest possibly take place, and, in fact, Strasburger himself mentions that the movement of water did come to a stop when the poison reached the top of the tree.

SUMMARY

Rhythmic activity being as a rule exalted by rise of temperature, suctional response, as one of its effects, also undergoes an increase.

Suction being an expression of excitatory response, the direction of the resultant movement of sap is determined by the relative excitabilities of the two ends of a tissue. Under certain circumstances, the normal direction of movement of sap may be reversed.

The application of cold produces a transient excitation, and thus causes a preliminary enhancement of suction. Prolonged application of cold, causing a depression of excitability, brings about arrest of suction.

As suction is produced by the rhythmic activity of the tissue of the entire plant, local death, as by scalding or application of poison, does not cause its arrest, until the whole plant is killed.

When the sum total of the latent energy of the tissue—that is to say, its tonic condition—is below par, its rhythmic suctional activity comes to a stop; fresh application of stimulus, however, renews this activity.

Osmotic substances, as regards their stimulatory action, may be either neutral or excitatory. If such a solution be applied at the root, there will in the former case be a diminution, and in the latter, if the excitatory action be relatively great, an increase of suction.

The application of poison abolishes local excitability and power of suction. In some cases this arrest of suction may occur quickly. But the total abolition of suction by poison only takes place, for reasons already explained, on the death of the plant as a whole.

CHAPTER XXX

THE PHENOMENON OF PROPULSION OF SAP AND ITS VARIOUS EFFECTS

The mechanics of the ascent of sap: (a) Uni-directioned flow—(b) Initiation of multiple rhythmic excitations—Connection between conduction of excitation and conduction of sap—Rapidity of ascent of sap accounted for by stimulatory action—Positive and negative pressures due to one cause—(1) Positive pressure—(2) Negative pressure—(3) Irregular variations of pressure—Direct conduction and conduction by relays—Excretion of water—Excretion of nectar—Translocation of organic food-substances—Mechanical response to suctional activity—Effect of warmth—Effect of cold—Explanation of the drooping of leaves during frost—Explanation of response and recovery—Antagonistic actions of internal energy and external stimulus.

THERE are various phenomena connected with the transport of water in plants, which are at present considered as entirely distinct. Thus, for example, when a plant is cut above the root, the exuding water exerts a considerable positive pressure on a manometer, this being known as root or exudation pressure. But when manometers are inserted in lateral holes bored in the trunk of a tree, a negative pressure is observed. These facts have led to the inference that there exist, in a transpiring plant, two independent forces, one of suction, and the other of pressure. The negative pressure, again, which is, generally speaking, maximal at the top of a tree, falls to a minimal value near the root. But this fall is characterised by very irregular fluctuations, the negative pressure, in a zone below, being sometimes greater than that at a given distance above.

I shall now proceed to show, however, that these very various results are not actually due, as supposed, to the operation of distinct forces, but are, on the contrary, so many different effects, under different conditions, of the rhythmic

cellular activity of the plant-tissue. I shall show that this activity is sufficient to account not only for the phenomena of the excretion of solution from pores and nectaries, but also for other phenomena, whose connection with it has been little suspected.

The mechanics of the ascent of sap.—We have seen that throughout the plant there are active rhythmic tissues, which by their excitatory activity bring about the movement of water. We have next to inquire, therefore, as to how this excitatory action is initiated, and further in what manner so many activities in different zones of the stem are correlated, so as to give rise to a uni-directional flow, generally upwards; for the rhythmic activity which may cause any given group of cells to act as a pump, would not alone be sufficient to account for the regulated, one-directioned flow of sap, since, while one such group propels water in one direction, there is no obvious reason why another should not propel it in the opposite.

(a) *Uni-directioned flow.*—In connection with the transmission of multiple excitatory waves, such, for example, as those which we have seen in *Biophytum*, it is important to note that these repeated excitations are all initiated at the original point of stimulation, and are propagated in proper sequence from point to point outwards. Thus, after each wave of excitation is exhausted, it starts anew from the original point. This sequence of multiple excitations is exactly parallel to that which is observed in multi-ciliated tissues in which the cilia repeatedly contract in sequence. Thus a single cilium at one end gives, as it were, a signal which is followed serially by the rest.

This being so, it is clear that if such a multi-ciliated tissue take the form of a hollow tube, with the ciliated surface inwards, and if the tube be filled with water, then, owing to this peculiarity of the multiply-responding cilia, the water will always be driven in one direction. A somewhat similar phenomenon occurs in the blood-circulation of animals, where the *sinus* giving the signal, the rhythmic contraction of the

heart proceeds towards the ventricle, and the pumping-action thus initiated produces a one-directioned flow of fluid.

In the leaf of *Biophytum*, strongly excited at, say, the inner end, we have similar rhythmic excitations, passing in regular succession from leaflet to leaflet, the innermost leaflet, which is near the seat of multiple excitation, giving the signal to the rest. And just as rigid sequence is observable in the movements of motile cilia, so it is also seen in the plant, by the depression in orderly series of its lateral motile leaflets.

(b) *Initiation of multiple rhythmic excitations.*—We have just seen that in multiple rhythmic response, the multiple waves of excitation proceed serially outwards, from the point of excitation. We also saw in Chapter XXI. that the wave of excitatory contraction is attended by the propulsion of water in the direction of propagation of excitation. It remains to be determined, then, with regard to the ascent of sap in a plant, how this one-directioned propagation of excitation is initiated.

In the case of an intact plant, the root is acted on constantly by various forms of stimulation, among which are (1) contact with the soil; (2) friction of the growing organ against rough surfaces; (3) turgor of its own tissues, due to absorption of water; and there may also be in addition, stimulation by (4), chemical substances of various kinds in the soil, which possibly exert some excitatory influence. All these factors, separately or in combination, serve to set up multiple rhythmic excitation at the extremity of the plant, and the excitatory effect is transmitted upwards, preferably along certain better-conducting tissues. Similarly, in the case of a cut branch placed in water, rhythmic excitation is initiated at the lower end by excessive turgor, just as we found rhythmic movements to be initiated in *Desmodium* leaflets at standstill, by the artificial increase of internal hydrostatic pressure, that is to say, by excessive turgor (p. 348).

Connection between conduction of excitation and conduction of sap.—It was said in the case of the intact plant

that excitation is transmitted upwards by conducting tissues and we have already seen, in studying transmission of excitation (p. 250), that the fibro-vascular elements are those which conduct best. It is therefore to be expected that the movement of water, which is itself an excitatory effect, should also follow by preference the length of the fibro-vascular elements; and it is here worthy of note that the ascent of sap is known to take place preferably along such channels. Again, I have shown (p. 250) that the power of conducting excitation is greater along the length of the plant than across; and we find also that the same is true as regards the transport of water, which is known to be greater in the direction of length. Conduction of excitation takes place with very great slowness across parenchymatous tissues, and the same is the case as regards the conduction of water through such a tissue. If, further, a plant were to be excited from above, instead of below, the transmission of excitation would be downwards, instead of upwards. We might then conceive of the possibility of reversing the direction of the normal transport of water. In such a case, rhythmic excitation would need to be initiated at the top, instead of at the bottom, of the plant. This may be seen in the experiment already referred to, of placing a leafy branch upside down, with its leaves in water. Rhythmic activity due to excessive turgor being now initiated at the upper extremity of the branch, the water-movement is reversed, and sap exudes from the cut end of the stem. Turning back, however, to the subject of the transmission of excitation, we have found, it will be remembered, in the case of *Biophytum* that this takes place with greater rapidity in a centrifugal than in a centripetal direction, that is to say, in the direction of the normal transport of water. It is therefore interesting to note that a reversed water-movement is, in general, known to be somewhat less rapid than the normal flow.

Rapidity of ascent of sap accounted for by stimulatory action.—One great difficulty with regard to the ascent of sap has lain in its relatively great rapidity. No theory

hitherto suggested has been held to account for this. As, however, we now find that the ascent of sap is due to the propulsive energy of vigorous excitatory contraction proceeding from cell to cell, the rapidity of the movement is easily understood.

We thus see how by the action of this cellular machinery, set in motion by stimulus, an upward movement of water takes place. We have in fact an active chain of pumps, working throughout the length of the plant, partly carrying water themselves, and partly pumping it into the better conducting vessels of the xylem; and there is no limit to the height to which it may, by such means, be lifted.

Positive and negative pressures due to one cause.—Let us suppose an india-rubber pipe, open at its upper end, and provided throughout its length with a series of pumps, one above the other, each of these being independently engaged in raising water upwards. The individual activity of these several pumps may or may not be uniform, but, provided that they are sufficiently numerous, when the pipe is placed in connection with a supply of water, the result of their combined action will be that water will be sucked in at the lower end, and ejected at the upper, in a uniform stream.

If now we confined our attention to the lowermost pump, it would appear to us to be *forcing* water up; if, on the other hand, we observed the uppermost pump alone, it would appear to be *sucking* water up; and if, finally, we selected some intermediate point for scrutiny, we should discover that the pumps above were sucking, and those below pressing water upwards. Thus, one single effect, namely, the rhythmic activity of pumps, is made to appear various, by simply changing the point of view. Again, certain peculiarities of variation of pressure may appear in the pipe as a whole or in particular parts of it, depending on the rates of supply and removal of water.

(1) **Positive pressure.**—We may now suppose the aperture of escape at the upper end to be narrowed. The water pumped into the flexible pipe being thus in a state of

compression, will produce a bulging or over-turgidity, and a manometric tube inserted laterally will indicate a positive pressure. Or if, under these circumstances, we make a cut in the pipe, we shall observe exudation under pressure. Now, this corresponds to the exudation pressure, causing so-called 'bleeding,' which we find on making incisions in plants in spring time, when the loss of water by transpiration is feeble, the buds being still unfolded; or even in summer, if transpiration be by any means prevented.

In connection with this exudation of sap, we have to remember that the whole question is one of income and expenditure. Generally speaking, the loss by transpiration is less at the end of winter or the beginning of spring than in other seasons. Thus the wild date palm, or *Phœnix s. 'vestris*, yields considerable quantities of sugary sap from incisions in the stem, at the end of winter or the beginning of spring. In the case of the Palmyra palm (*Borassus flabelliformis*) of Bengal, however, the increase of cellular activity in summer more than compensates for the loss by transpiration, and sugary juice is collected in the height of summer at the top of the tree by incisions in the peduncle. The pressure exerted by the sap may be gathered from the fact that these trees are often more than a hundred feet high.

(2) **Negative pressure.**—We may next suppose that in the chain of pumps, those at the upper end are the most active, and the aperture of escape wide open, the removal of water being further aided by evaporation. The loss of water being thus greater than the supply, it is clear that there will be a negative pressure in the pipe, and the mercury in a testing lateral manometer will be sucked in. This corresponds to the negative pressure exhibited by an actively transpiring plant. In such a case it will be noted that the activity of the rhythmic cells, which is the fundamental cause of the ascent of sap, is further aided by the evaporation from the leaves. Concentration of cell-sap also, and the osmotic action thereby produced, may then constitute an additional auxiliary factor.

When the stem of an actively transpiring plant is cut across, the stump of the plant does not always immediately show bleeding, but often, on the contrary, will suck in water. This is generally ascribed solely to the existence of negative pressure in the stem. There is another element in the problem, however, which is generally overlooked. By such stimulus as that of amputation, excitation must be produced at the cut end of the stem, which is propagated downwards, and tends to induce a reversal of flow. But when the negative tension and the excitatory effect, due to stimulus of cut, have both subsided, exudation will begin to take place.

(3) **Irregular variations of pressure.**—It is evident from what has been said that the hydrostatic pressure at any given zone of the tissue will depend on the relative activities of cells below and cells above. Cells immediately above, by their activity, produce suction or negative pressure; and those immediately below, an increase or positive pressure. The resultant pressure at any individual zone depends, therefore, on the algebraical summation of these. Now, though all the cells throughout the length of the plant may be active, yet there will be some difference in their activities. Or the same cells again, at different periods of life and different conditions, may undergo variations of their activity. There are, in nature, many disturbing influences which produce local variations of excitability; hence, by the distribution of cells whose excitabilities are irregular, we may obtain a variation of internal pressure from the top to the bottom of the plant, which is not uniform but fluctuating.

Direct conduction and conduction by relays.—I have already said that the movement of water, being mainly brought about by excitatory reactions, will take place preferentially along conducting channels. We have seen that every tissue possesses the power of conduction to a greater or less degree; in parenchymatous cells, however, owing to the presence of numerous more or less complete septa, transmission is enfeebled, whereas in prosenchymatous fibrovascular elements it is very much facilitated. Thus, for

conduction through long tracts, the fibro-vascular tissues are the most favourable. But even in this case the transmission of the excitatory effect may be much enfeebled by distance. Or an interposition of parenchymatous elements may offer a relative obstruction to the transmission. In such cases there might be pseudo-conduction by means of 'relays.' For as an example of the last case we may imagine a mass of excitable parenchymatous tissue, against which a conducting tissue abuts. This mass, being supplied with water by the conducting elements, may become over-turgid, and thus rhythmic activity may be initiated in it *de novo*.

That rhythmic activity may under favourable circumstances be started locally in a mass of excitable tissue, we have seen in the case of the pulvinus of *Desmodium*. For the fact that activity in this case was not due to any transmitted impulse was proved in the experiment on the localisation of the excitable area, when it was found that an isolated leaflet, if sufficiently turgid, could pulsate. Under natural conditions, the necessary turgidity is maintained by the cellular activity of the tissue below. It is worth while to remember, in this regard, that the characteristic pulsation of the leaflet has no immediate connection with that rhythmic activity of the plant-tissue which brings about the ascent of sap. The period of pulsation of the leaflet is determined by certain constants of its cell-complex. We may in fact have various vibration-periods in different organs of the same plant, the different oscillations being brought about by the turgidity caused by the ascent of the sap, just as the same electrical current may give rise to various frequencies of vibration of different electro-magnetic vibrators included in the same circuit.

Excretion of water.—The rhythmic activity of a mass of excitable cells is seen again in the case of such as actively excrete water. A very striking example is that of *Colocasia esculentum*, in which the successive expulsions of water-drops noticed by Musset were as many as eighty-five in one minute.

A distinction is sometimes made between this excretion—due to the special local activity of a certain group of cells—and the somewhat passive excretion of water from water-pores, which is said to be caused by the general pressure of exudation. But this difference is really one of degree and not of kind. All cells are excitable, and the exudation pressure itself is produced by cellular activity. As regards excitability, however, we may have a transition from moderately to highly excitable cells distributed in a continuous or discontinuous manner. Even in the stem we have seen that there are cases of irregular distribution, bringing about irregularities of water-pressure. Extreme instances of these are found in *Desmodium*, and in the actively excreting cells of *Colocasia*, where highly excitable cells are localised in special areas. A test which is sometimes insisted on as a means of distinguishing between the active and so-called passive excretions is, that in the latter case the flow ceases from the excreting organ, as soon as the branch is cut off. But this is not by any means a satisfactory proof of the absence of active excreting cells in the latter. We saw that the only distinction between the activities of the multiply-responding tissues of *Biophytum* and *Desmodium*, lay in the fact that the latter had the capacity to hold latent a large amount of energy by which the rhythmic activity was maintained even on the cessation of a directly exciting cause. In the case of *Desmodium*, indeed, if the tonic condition be above par, and the leaf as a whole be cut off and isolated, without any supply of water, the rhythmic activity will be maintained for a considerable time, though the turgidity is undergoing constant diminution. But when the tonic condition of the plant is below par, its rhythmic activity comes to a stop, and can only be maintained by an artificial increase of internal hydrostatic pressure. Similarly in the case of water-excreting organs, we have some which under a favourable condition can maintain their activity for a considerable period, even when the supply of water is cut off, while in other instances activity can be maintained only under favourable conditions of turgidity.

Excretion of nectar.—It is often assumed that the excretion of nectar is due to plasmolytic action. The excreted solution of sugar dries up by evaporation, and this by plasmolysis draws up more from behind. We have seen that the ascent of sap in the plant is brought about mainly by rhythmic activity, and that concentrated solutions in the leaves may help this movement osmotically. In the case of nectaries, the presence of concentrated sugar solution outside may thus help continued excretion, but this does not explain the initiation of excretion, which could only have been caused by the rhythmic activity of cells.

Translocation of organic food-substances.—Though the flow of organic food-materials towards places where there is a deficit may be brought about by diosmosis, yet such a mode of diffusion must be extremely slow. A more rapid transport than could be produced by this means would appear to be a necessity. There are certain considerations moreover which may be brought forward, tending to show that this translocation of food-materials receives considerable aid from stimulatory actions. Czapek's observation, too, that there is a cessation of translocation in a chloroformed leaf-stalk, points to the inference that it is a physiological process.

We know that an excitatory action proceeds from the more to the less stimulated. Now the accumulation of a large quantity of organic food-material may of itself act as a stimulating agent in a given case; thus an excitatory movement would proceed from cell to cell, from places where there was excess to places where there was deficit. In this way large quantities of food-materials may be rapidly transported by excitatory reaction, through conducting channels. And such transport is also possible by stimulatory action even through unspecialised cells. These ordinary cells are known to be connected with each other, by means of pores and plasmic threads. Mr. Horace Brown has shown (*Phil. Trans.* vol. cxcii.) that transport of fluid may take place through such a 'multi-perforate septum' with almost as great rapidity

as if no closing membrane were present. It is clear that by the contracting expulsive action of excited cells, transport of materials might be brought about more rapidly than by mere osmotic action.

Mechanical response to suctional activity.—The effect of that internal rhythmic activity which, as we have seen, is caused by the absorption of energy from various forms of stimulus, is to induce an increase of turgidity throughout the plant. I shall next proceed to describe a mechanical means of obtaining some indication of this internal activity.

I have shown that owing to the dorsi-ventral differentiation in the pulvinus of *Mimosa*, when the turgidity of the organ is increased, the leaf is erected; and when the turgidity is decreased, as by the direct action of an external stimulus, the leaf is depressed. Similar effects occur not in pulvinated organs alone, but in all dorsi-ventral organs, in which the lower half is more excitable than the upper. Thus, for example, the lower half of the petiole carrying the lateral leaflets of *Biophytum* is more excitable than the upper half. It is true that the leaf possesses a slightly developed pulvinus; the differential excitability on which the motile response depends is not, however, confined to this pulvinus alone, but extends throughout the length of the petiole. The petiole thus acts like a diffuse pulvinoid.

The action of stimulus on the diffuse pulvinoid of *Biophytum* and on the pulvinus of *Mimosa* is to produce the fall of the leaf. And just as the leaf of *Mimosa* was erected by increased turgidity, so in *Biophytum* also we should expect to have, with similar increase of turgidity, a similar responsive movement of erection; and this I find to be the case. The erection of the leaf of *Mimosa* or *Biophytum* is therefore a mechanical indication of an increase of turgidity or of positive turgidity-variation, by whatever means this may have been induced. Such an increase may be brought about by an augmentation of suctional activity. And the up movements of dorsi-ventral

petioles in which the lower surface is the more excitable may thus be taken as mechanical indications of such added activity.

Effect of warmth.—We have already seen that application of warm water to the root of a plant, increases its suctional activity. I was able to demonstrate this fact by means of the mechanical response of *Mimosa* and *Biophytum*. On making the application, the leaves of both plants responded by erection to a position which in the case of *Mimosa* was 9 mm. and in the case of *Biophytum* 12 mm. above normal. A rise of temperature we have also seen to have the effect of enhancing the internal energy of the plant. By doing this, it brings about an erection of the leaves.

Effect of cold.—We have seen, on the other hand, that the effect of cold is to stop rhythmic activity, and thereby to arrest the ascent of sap. The motile indication given by the leaf would in this case be the opposite to that of positive turgidity-variation, that is to say, would consist of a fall or droop. On applying ice-cold water to the root of *Mimosa* I found that the effect of cooling was to induce a lowering or drooping of the leaf, to a position of 3 mm. below the normal. In *Biophytum* the corresponding fall was through 5 mm. Lowering of temperature, by depressing the internal energy of the plant, has the same effect.

Explanation of the drooping of leaves during frost.—These experiments offer an explanation of that drooping of leaves which is observed in frost, and of the disappearance of this drooping when a plant is restored to a warmer atmosphere indoors; for we have seen that when the internal energy of the plant is normal, or above par, its suctional activity and consequent turgidity are high, this favourable internal condition being outwardly exhibited by the erection of the leaves. But when the internal energy is below par, the reverse effect is seen in their droop or fall.

Explanation of response and recovery.—It has been stated, when describing the effect of stimulus in inducing a fall of the leaf, and its subsequent erection, that the latter

movement, namely, that of recovery, was an active and not a passive process. Certain experiments that I am about to describe will enable us to analyse response and recovery still more closely.

When an organ is locally excited, the contraction induced results in an expulsion of water, thus reducing the turgidity of the organ, and the consequence of this is a mechanical fall of the leaf. Some internal activity now forces the water back into the organ from which it was expelled, and we have the recovery or erection of the leaf. That it is the internal energy of the plant to which this recovery is due, will be seen clearly from the following experiment. A leaf of *Biophytum* falls, as has been said before, when it is stimulated, whatever be the form of stimulus. I shall explain in my chapter on the effect of stimulus of light, that the effect of photic stimulus is the same as that of any other form, while its special advantage is that it may be applied without causing any mechanical disturbance, and that its intensity can be very easily regulated.

On subjecting a petiole of *Biophytum*, therefore, to the action of sunlight, the leaf responded by depression, the average rate of fall of the tip of the leaf being .16 mm. per minute. In half an hour it had passed through almost 5 mm. On now shutting off the light, the after-effect persisted for another five minutes, when there followed recovery by slow

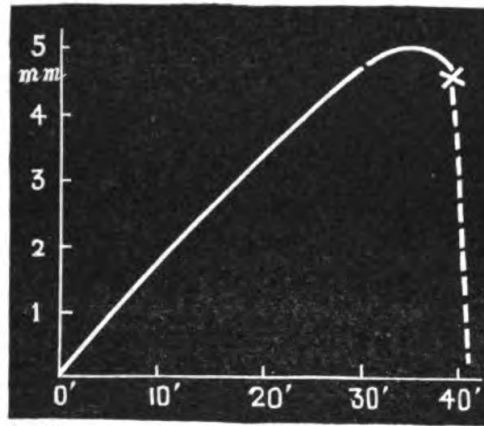

FIG. 166. Record showing Recovery to be Hastened by the Increase of Internal Activity which is caused by Application of Warm Water to the Roots

The first part of the record shows the fall of the leaf, due to direct stimulation by sunlight during thirty minutes. Stimulus is next cut off at point marked by interruption of record. After-effect persists for five minutes, and there is a subsequent slow recovery. Warm water applied to root at moment \times , with the result of quickening the rate of recovery by fifteen times.

D D

erection of the leaf at a rate of $\cdot 12$ mm. per minute. Warm water was now poured on the root, thus suddenly increasing the internal activity of the plant. Now, if it be true that recovery is brought about by this factor of internal energy, then the increase of internal energy ought to produce a sudden augmentation of the rate of the recovery. That this is the case will be seen from the record (fig. 166), where it will be noticed that the enhanced rate of recovery from this point is $1\cdot 8$ mm. per minute, that is to say, fifteen times the normal rate.

Antagonistic actions of internal energy and external stimulus.—We thus see that it is the internal energy of the plant—vaguely known as a favourable tonic condition—which actively determines the recovery of the organ. This will explain the fact which I have mentioned elsewhere, that in summer, when the internal energy is considerable, the leaf of *Mimosa* recovers from the effect of stimulus in about six minutes, whereas in winter, when the internal energy is low, the same process may take as long as eighteen minutes. We thus see that as regards mechanical response the external stimulus and internal energy act antagonistically. Local external stimulus induces a diminution of turgidity, while internal energy causes an increase of turgidity. Thus when the internal turgidity is very great it opposes the mechanical response to external stimulus. This we saw in the case of over-turgid leaves of *Mimosa*, and in those of *Artocarpus* during the rainy season, which, though excited, did not exhibit mechanical response to stimulation (pp. 49, 58).

This will be clearly understood also from an attentive consideration of the experiment, the record of which is given in fig. 166. In that case, had the warm water which increased the internal activity been applied earlier at the root, that is to say during the application of external stimulus, the induced internal turgidity would then have been so great as to arrest the responsive down movement of the leaf. The amplitude of the response to external stimulus would thus have undergone diminution or even abolition.

We must remember, however, that the internal energy which maintains the normal turgid condition is itself the result of energy previously absorbed from external sources ; and if the plant be cut off from these sources of external energy, then its own tonic condition will fall below par. Thus the leaves of many plants are seen to droop when kept too long in darkness, and exposure to light makes them recover their natural position of normal turgidity. Hence in the case of a plant whose condition is sub-tonic the leaves may be made turgid by exposure to light ; but after the attainment of the normal tonic condition, exposure to strong light will bring about the proper contractile response to stimulus, with the characteristic external motile indication of diminished turgidity.

We have thus seen the various effects produced by the internal or latent energy of the plant. We have seen it bring about the ascent of sap by means of the increased activity of the plant-cells. It was seen to produce exudation pressure, and excretion of nectar from intact plants. We have traced it out to its appropriate expression by the lateral movements characteristic of positive turgidity-variation, in the case of anisotropic or dorsi-ventral organs. We have seen, too, how necessary it is to the production of recovery of an organ from the action of an external stimulus, the effects of local external stimulation, and of this internal activity, being opposed in character. Any increase of this internal energy is thus a factor tending to hasten the recovery of the organ from stimulation, and when it is sufficiently great, it may, by its antagonistic action, reduce the amplitude or even abolish response to external local stimulus. We have again seen this internal activity finding motile expression in the autonomous movements of leaflets of *Desmodium* ; but, for its mechanical exhibition, we need not confine our attention to the sensitive plants so called, for we shall find the same internal activity exhibited mechanically by all plants, in their rhythmic growth-responses, to be described in the following chapters.

D D 2

SUMMARY

The ascent of sap is fundamentally due to excitatory reaction, its uni-directioned flow being brought about by the passage, from point to point, of the co-ordinated excitatory reaction, propelling water forward.

This rhythmic excitation is initiated in the intact plant at its root, by stimulus of contact with soil, the friction of the growing organ against rough surfaces, the excessive turgidity caused by the absorption of water, and possibly by the chemical stimulus of substances present in the soil. In the case of cut branches placed in water, the excessive turgidity at the cut end initiates rhythmic activity. Again, if stimulus be applied at the top instead of at the root, the direction of water-conduction may be reversed, along with the reversal of propagation of excitation.

The following facts show the intimate relation between the conduction of stimulus and conduction of water :

(a) The movement of water takes place preferentially through the fibro-vascular elements, these being also the better conductors of excitation.

(b) The conduction of excitation along a plant is greater than across. The same is true of its power of transport of water.

(c) Though conduction of excitation may take place either upwards or downwards, yet there is a preferential direction for such conduction. The same is true of the transport of water.

The same movement of water produced by the co-ordinated rhythmic activity of cells throughout the plant appears as either suctional or pressure movement, according to the point of view.

When the removal of water from the plant is in any way arrested, a positive pressure is produced, owing to the excessive accumulation of water. When, on the other hand, the

loss of water by transpiration is greater than the supply, a negative pressure will be observed.

The ascent of sap primarily due to cellular activity, may be secondarily aided by evaporation from the leaves, and the osmotic action of the concentrated cell sap in the leaves.

Owing to the distribution of unequally active cells, an irregular variation of pressure is induced in the stem.

The excitatory movement may be transmitted to a distance by conduction, or there may be conduction by 'relays.' An isolated mass of highly excitable tissue may thus be excited *de novo*.

The excretion of water and of nectar are phenomena of cellular activity, analogous to that which brings about the ascent of sap.

The translocation of food-material is also probably due, at least in part, to excitatory reaction.

The internal activity of the plant, causing increase of turgidity, may be detected mechanically by that erection of the leaf which is characteristic of the positive turgidity-variation.

Any increase of internal activity is exhibited in dorsiventral organs, such as the petioles of *Mimosa*, *Biophytum*, and *Artocarpus*, by the erection of the leaf. Thus, when the internal energy of the plant is increased by a rise of temperature, the leaves become erected. Conversely, under the action of cold, on account of the diminution of the latent energy, the opposite effect, or droop, is induced. This explains the drooping of various leaves during frost, and their subsequent erection when brought into a warmer atmosphere.

This internal energy is also an important factor in bringing about the recovery of an organ from the effect of external local stimulus. The effect of external local stimulus in causing the diminution of turgidity of an organ is thus antagonised by the internal activity, which causes an increase of turgidity.

The internal energy, when sufficiently great, may thus hasten the recovery of the organ from the effect of stimulus.

This increased internal energy may also reduce the amplitude, culminating in the total abolition of mechanical response, as seen in over-turgid *Mimosa*, or in *Astocarpus* during the rains.

PART VI
GROWTH

CHAPTER XXXI

THE RECORD OF GROWTH-RESPONSE

The simple ~~Growth-Recorder~~ — The Balanced ~~Growth-Recorder~~—Rhythmic growth-response—Growth-response and excitatory response—Law of direct and indirect effects of excitation—Positive turgidity-variation as indirect effect of excitation—Mechanical test—Significance of 'inner stimuli.'

ONE of the most characteristic manifestations of life is growth. The question then arises, whether this particular manifestation is to be regarded as a distinct and specific phenomenon, unlike all others, or whether it may be possible to trace a connection between it and those responsive reactions with which we are already familiar.

The occurrence, in response to stimulus, of numerous growth-curvatures, sometimes positive and sometimes negative in character, offers us again a problem of very great complexity. It is sometimes supposed that stimulus retards, and sometimes that it accelerates, growth. But it is difficult to understand how the same influence can produce opposite effects. Then, again, there is intruded upon the problem the unknown effect of 'inner stimuli.' From all these it will be seen that the subject of growth and growth-movements is one of extreme obscurity, and that the difficulties which baffle us can only be met satisfactorily if we are able to analyse and follow out, one by one, the various elements that enter into the problem.

We have seen in the *Desmodium* leaflet at standstill, and in that of *Biophytum* under ordinary circumstances, that when the latent energy is not excessive, we obtain a single movement in response to a single stimulus. When the sum total of the latent energy of the tissue, however, is above par,

it is manifested in a rhythmic manner, by periodic variations of turgidity, bringing on responsive movements. It was also stated that responsive movements under the action of stimulus took place in ordinary young tissues, these movements being lateral when the tissue was anisotropic, and longitudinal when it was strictly radial. It would follow, then, that when the sum total of the latent energy in such tissues was above par, they might be expected—like the leaflet of *Biophytum* or *Desmodium* under similar conditions—to exhibit their rhythmic excitation by repeated lateral or longitudinal movements. I shall now proceed to show that in the case of these young tissues, under favourable circumstances, this multiple rhythmic excitation finds expression in the responsive movement known as growth.

In the majority of instances an organ is not absolutely radial ; hence, during growth, we obtain the lateral responsive movements which are known as circumnutation. In bilateral growing organs, these movements are to and fro, in strict parallelism to the to and fro movements of the leaflet of *Biophytum*. In such instances the axis of bilaterality is fixed, and the responsive movement takes place in a definite plane. In the leaflet of *Desmodium* also rectilinear movements are often observed ; but as a rule, owing to the revolution of the bilateral axis, the movement of the leaflet is circular or elliptical, and in the case of growing organs, from the same cause, circular or elliptical movements of nutation are common. The ideally simple and most interesting example of this multiple rhythmic activity is seen, however, in the growth-movements of radial organs, these being longitudinal ; for there is not in this case that complication which arises from the gradual shifting of the bilateral axis seen in the growth of anisotropic organs.

In order to prove the identity of these rhythmic growth-movements with multiple response, we have to show (1) that such rhythm is a characteristic of growth ; (2) that each pulsatory growth-movement of the series exhibits all the characteristics of true response ; (3) that the series itself

is characterised by the same cyclic variation which we have observed in the case of multiple response ; (4) that just as the application of appropriate stimulus renews pulsation in a *Desmodium* at standstill, so, in a plant with growth at standstill, appropriate stimulation renews pulsatory growth ; and, lastly (5), that the modifying influence of external agents is similar in both cases.

From a series of observations, taken at intervals of several minutes, on *Spyrogyra princeps*, Hofmeister found that growth undergoes fluctuation, the first and second maximal points in his series of observations being separated by an interval of forty-four minutes, and the second and third by an interval of ninety-five minutes. Such experiments, however, have laboured under the great disadvantage of discontinuity, and in order to overcome this I undertook to devise some apparatus by whose means growth-pulsations might be recorded continuously, in such a way as to give not only the period, but also the individual peculiarities of each pulsation. And I may here forestall matters to say that by such means I have been able to detect longitudinal pulsations two hundred times as quick as those observed by Hofmeister.

Conditions to be kept in view.—Before attempting to demonstrate the pulsatory character of growth-movements, however, I shall point out certain facts which it is essential to remember. We have seen that under rapidly succeeding excitations, the separate responsive effects become merged, and a response is produced, which is apparently continuous, although the stimuli themselves were discontinuous. This is seen, for instance, in the first part of the tetanic curve (figs. 49, 50). But when once the maximum responsive effect is produced, as there can be no further additive effect, the subsequent responses show themselves in a series of fluctuations of the top of the tetanic curve. In that form of response, which we are now considering, as there is no maximum limit, the additive effect of growth continues indefinitely. It is thus clear that when rhythmic excitation is very rapid, it may produce a growth-movement which

appears to be continuous. But when this rapidity is not excessive, it should be possible, by employing sufficient magnification and a suitably quick rate of movement of the recording surface, to display its actual pulsatory character. The sensitiveness of this mode of detection becomes again very much increased if we employ the method of balance, or compensation, which will be described presently. We thus require a high magnification, and some means of continuous record.

A high magnification may be produced by microscopic optical projection, but this labours under the great disadvantage that the specimen is subjected to the strong and unilateral stimulus of light, by which its normal growth-movements are greatly modified. The ordinary auxanometric method, again, cannot be employed, (1) because the magnification produced is not sufficiently great; and (2) because the inertia of the wheel, and the unavoidable friction of the apparatus, themselves combine to obliterate the quick pulsations of the growth-response.

The Crescograph.—All these difficulties were overcome by the use of my Optical Lever, for making growth-records. The lever is made extremely light, and the fulcrum-rod rests on agate planes. When the tip of the growing organ is attached by a thread to the short arm of the Lever, the length of the latter being .5 cm., and when the recording surface is at a distance of 2.5 metres, a magnification of 1,000 times is obtained. This is in most cases more than sufficient. But, when necessary, a magnification of 10,000 times can easily be secured. In order to avoid any disturbance due to vibration in the room, the apparatus is supported on a steady bracket, fixed on the wall. Using these ordinary precautions, records are obtained with this instrument which are absolutely free from external disturbance.

The Balanced Crescograph.—In records of growth we obtain a sloping curve whose abscissa represents time; and ordinate, the elongation produced in the organ during

that time. A variation of growth will produce a variation in the slope of the curve. When this variation of growth, however, is slight, the variation of slope of the curve is so small as not to be detected. It was in order to detect and measure such small variations that I devised the Method of Balance, in which the average rate of growth is represented by the horizontal line of balance, any fluctuation, even the slightest, appearing as a deviation from this horizontal. The influence of various agencies, again, may be displayed in a marked manner, by using this method ; for in such cases we do not so much require the rate of growth itself, as the *variation*—*i.e.* acceleration or retardation—in the normal rate, which is induced by one agent or another.

The principle of the Method of Balance consists in making the spot of light—which is moving in response to growth—become stationary, by subjecting it to a compensating movement. An example will make this clear. We shall suppose the average rate of growth to be 1.2 mm. per hour. This will cause an excursion of the moving spot of light, from, say, left to right, through 1,200 mm. by the end of the hour, in that case where the magnification is 1,000. Had the growth been uniform, this would have meant a movement of 20 mm. per minute. But if not uniform, the rate might sometimes have risen above, and at others fallen below, this average. If now we subject the spot of light to a uniform compensating movement, such as by itself would have made it move from right to left of the recording surface, to the extent of 1,200 mm. by the end of the hour, we shall find that, being acted on by these two opposite movements, of growth and compensation, the spot will remain approximately on a single base line of compensation. The fluctuations, or variations, which have occurred in this average rate of growth, will, however, be recorded as deviations to one side or other of this mean neutral line. Thus it will be seen that the slightest deviation from a uniform rate of growth, will be found displayed by the record of the moving spot of light. We are further enabled, from our

knowledge of the speed of the recording-drum, and the balancing rate, and from an inspection of the curve itself, to determine not only the periodicities, but also the absolute value of the rate of variation of growth, at any given moment.

The compensating movement to which I have referred is effected by means of an hydraulic device. The spot of light

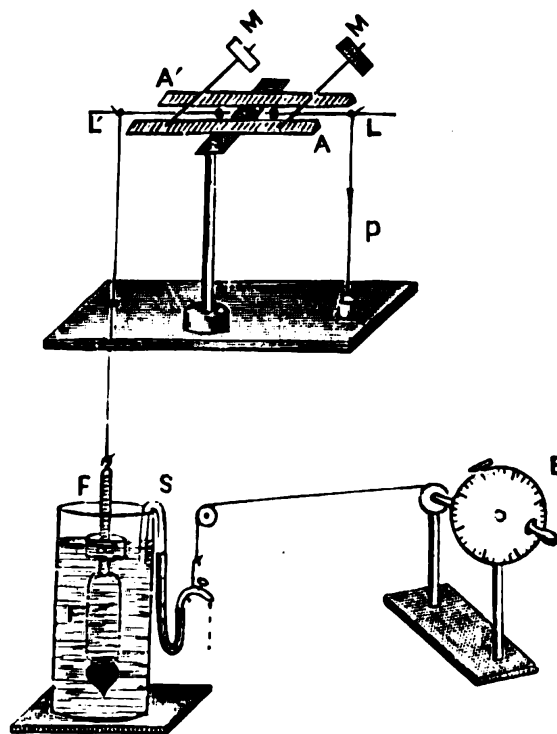

FIG. 167. Diagrammatic Representation of Balanced Crescograph

P, plant attached to Optic Lever, L, with mirror, M, attached to fulcrum-rod, resting on knife-edges, A and A'; L', lever attached to float, FF, with second mirror, M, attached to its fulcrum-rod; B, balancing wheel adjusting differences of level of the two limbs of syphon, s.

from the Optical Lever falls upon a mirror attached to a second lever, or to a rotating wheel. The arm of the lever, or a thread which is passed round the wheel, is attached to a float on the surface of a cylinder of water. Water is escaping from this cylinder, by means of a syphon arrangement, at a rate which can be adjusted with the greatest nicety. The float can thus be made to descend at any speed that is desired, this descent producing a rotation of the second lever or of the wheel.

We have, then, two mirrors, of which one is rotated in one direction by the growth-movement of the plant, and the second in the opposite direction by the descent of the float. A spot of light reflected on the two mirrors will thus remain stationary when the precise balance is effected, by proper regulation of the escape of water from the cylinder (fig. 167).

This outflow of water is roughly adjusted by opening the stop-cock, to a greater or less extent. The finer adjustment is then effected by the suitable variation of the difference of level in the two limbs of the syphon. One end is connected with a flexible india-rubber tube, which is attached to a string passing over a pulley, and fixed to the adjustable wheel B, attached to the observer's table. Rotation of the wheel in one direction will depress this end of the syphon, so increasing the flow, and in the other direction will raise it, so diminishing the escape of water. It will be noticed that the rate of outflow of the water is not in any way affected by the variation of level of the water in the cylinder. It simply depends on the difference of level between the two ends of the syphon. The rate of descent of the float is thus regulated with the utmost nicety, till an absolute balance is obtained. The observer recognises the condition of balance when there is no drifting of the spot of light on the recording drum. The adjusting wheel is now fixed at this position of balance. If any agent should induce an acceleration of growth, the balance is disturbed, and the spot of light moves, say, to the right, or in a positive direction. Any agent which induces retardation will, on the other hand, cause a deflection of the spot of light in a negative direction. Should there be any natural fluctuations in the growth, the oscillation of the spot of light will give an indication of the fact.

The record is made in the usual manner on a revolving drum. Fig. 168 illustrates the complete apparatus, which enables us to obtain a record under balanced—or by closing the stop-cock of the syphon, also under unbalanced—conditions.

The wheel is graduated, and the absolute value of the compensatory movement, at any position of the circular scale, can be previously calibrated, by fixing the plant-mirror, and observing the extent of movement of the spot of light on the drum, due to the subsidence of the float in a given time.

For the exhibition of pure longitudinal growth-response, the most perfect specimens are the growing radial styles and

stamens of flowers. There are also other organs, which are more or less strictly radial, such as the peduncle and the hypocotyl. But in these latter cases care should be taken that the specimen have been so grown, that its different sides have been subjected to uniform conditions of light or darkness; for one-sided illumination tends to produce anisotropy.

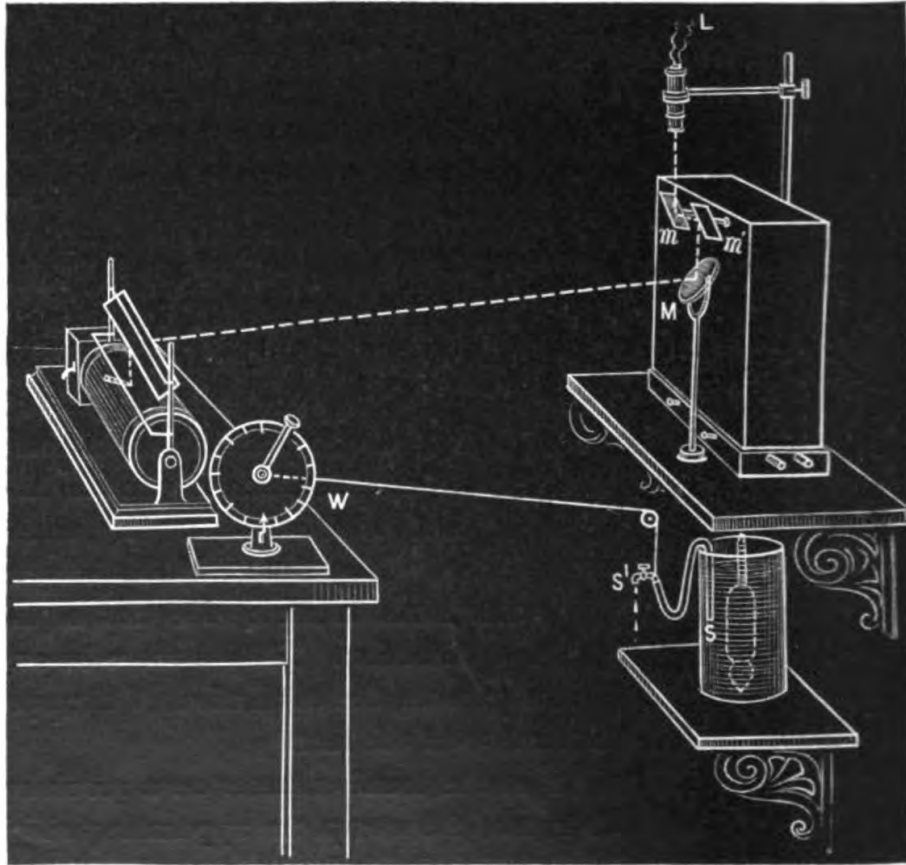

FIG. 168. Complete Apparatus for Crescographic Record under Ordinary and Balanced Conditions

With specimens of all the types mentioned, I have obtained multiple growth-responses when the constituent pulsations were not too rapid. In some cases, indeed, the effects were so marked that they did not even require a balancing arrangement to render them conspicuous. As an instance of this, I shall give a record of the growth-response of a

vigorously growing peduncle of *Crocus* which brings out in an interesting manner the mechanics of growth (fig. 169).

Rhythmic growth-response.—We saw that when the sum total of energy is above par, a tissue becomes self-excitatory in a multiple or rhythmic manner, giving rise to periodic turgidity-variations. There may thus be responsive pulsations of increased turgidity, each followed by slow recovery from such excess. With each such pulse, a transient elongation of the growing tissue will be produced, and the succeeding slow recovery will be more or less incomplete. This incompleteness is due to the deposit of material which fixes growth. The irreversible or permanent growth-effect produced by each pulsation, will thus be measured by the responsive elongation *minus* the recovery. This is well illustrated in fig. 169, where three separate sets of responses are given, taken from a single specimen in the course of the day. Growth, as will be shown, is not uniform throughout the day, but exhibits variation, in consequence of changing conditions, such as that of temperature. But for a short interval of time, the rate of growth under a constant environment, it may be taken as uniform. In the present

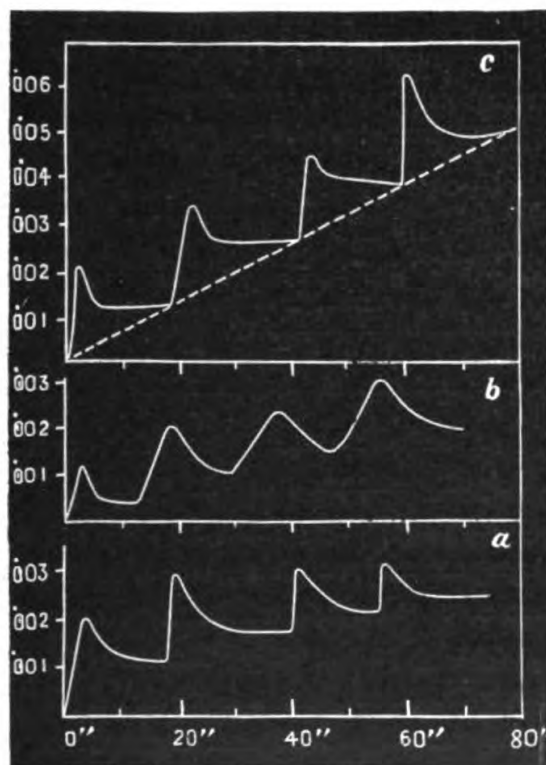

FIG. 169. Multiple Growth-responses (Peduncle of *Crocus*)

The ordinate represents the extent of responsive elongations in mm. ; the abscissa, time in seconds.

E E

instance the maximum rate was as high as $\cdot 0035$ and the minimum as low as $\cdot 0010$ mm. per minute. Confining our attention to the uppermost of these series (*c*), we find that the responsive elongation is very quick, and the recovery slow and incomplete. The average period of a single pulse is twenty seconds. The results of series (*c*) are given in the following table:

TABLE SHOWING PULSATIONS OF GROWTH

Number of pulse	Responsive elongation	Recovery	Permanent growth	Time
1.	$\cdot 0020$ mm.	$\cdot 0010$ mm.	$\cdot 0010$ mm.	20 seconds
2.	$\cdot 0023$,,	$\cdot 0008$,,	$\cdot 0015$,,	22 ,,
3.	$\cdot 0018$,,	$\cdot 0005$,,	$\cdot 0013$,,	18 ,,
4.	$\cdot 0021$,,	$\cdot 0012$,,	$\cdot 0009$,,	20 ,,
Total			$\cdot 0047$,,	80 ,,

It will be seen from this table that the total growth in eighty seconds is $\cdot 0047$ mm., giving an average rate of growth of $\cdot 0035$ mm. per minute. Had a magnifying arrangement not been used, this average rate of growth, shown by the dotted base line, would have appeared as continuous growth. By the magnification of the responsive curve, however, we are enabled to see that such a rate is in reality made up of numerous fluctuating growths of which it is an average.

Growth-response and excitatory response.—If we compare these multiple growth-responses with the multiple mechanical responses of *Biophytum* (fig. 116), their similarity is at once evident. As in that case, so here also, recovery is not complete, and the series of effects produced is therefore additive in both cases. With *Biophytum*, however, when the leaflet is depressed to the utmost, a limit is reached; but in growth there is no such limit, and the summation of effects may go on indefinitely, until senility and death supervene.

Yet there is a certain difference between these responses. In the case of *Biophytum*, the response is due to a sudden diminution, but in growth, to a sudden increase, of turgidity. This might at first sight appear anomalous, but I shall presently show that both are expressions of an excitatory reaction ; for we have seen that when the responsive organ of *Biophytum* is directly excited there is an expulsion of water, and the response is brought about by negative turgidity-variation. This variation we shall for the sake of convenience distinguish as *the direct effect* of stimulation. We saw in the last chapter, however, that an increase of the internal energy of a plant gives rise to an opposite response, that is to say, one characteristic of positive turgidity-variation. The two responsive turgidity-variations, then, both negative and positive, are alike in being expressions of the excitatory reaction, though the negative variation is the effect of external stimulus applied directly to the responding organ, while the positive variation is to be regarded as the effect of the internal energy of the plant. This internal energy may itself have been derived previously by the plant from external sources of stimulation, or the internal energy of a given point may result from the application of a stimulus at a distance. The pumping-in of water by the stimulated root is an example of the latter case ; the cells are thus made tense, and the potential energy of the tissue is raised above par. Again, we may conceive of another interesting instance as follows. When stimulus is applied at a distance the excitatory expulsion of water gives rise to a wave of increased turgidity, which produces an abnormal positive response, and this positive turgidity-variation we shall designate as *the indirect effect* of stimulation. The wave of true excitation may in this case reach the organ after that of positive turgidity-variation, and give rise to the direct effect of stimulation, that is to say, depression of the leaflet. We may next imagine that the seat of stimulus is at so great a distance from the responding organ, that the transmitted excitation becomes too much enfeebled, by the long tract which has to

be traversed, to produce the excitatory negative response. In this case, nevertheless, the sudden expulsion of water at a distance will give rise to a wave of increased turgidity, which will reach the responding organ, and produce there only that response which is characteristic of positive turgidity-variation.

Positive response as indirect effect of excitation.— Numerous experiments have been described exhibiting the negative turgidity-variation as the direct effect of stimulation. I have already described the production of positive turgidity-

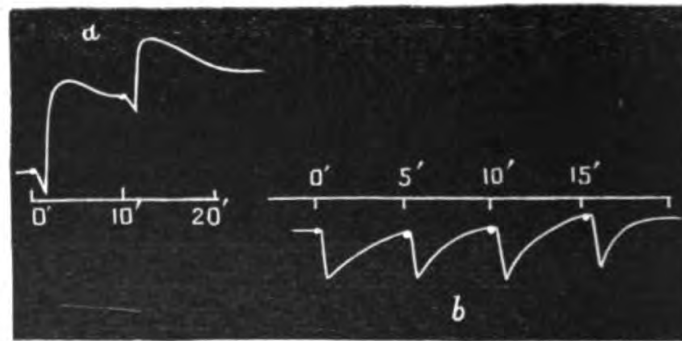

FIG. 170. Responses of Leaf of *Artocarpus* to Thermal Stimulation

Thick dots show points of application of stimulation. In *a* stimulus was applied near the responsive pulvinoid and gave rise to normal response of fall—here represented as up movement—preceded by preliminary erectile twitch. In *b* stimulus was applied at a greater distance. The true excitatory effect did not reach the organ, and we obtain positive erectile response of positive turgidity-variation, here represented as down.

variation as the indirect effect of stimulation (p. 400). A fuller demonstration of this, by the electrical method, will be found in Chapter XXXVII. I shall here give an experiment which establishes the fact by means of mechanical response. In fig. 32 (reproduced in fig. 170, *a*) was shown a series of normal mechanical responses of negative turgidity-variation obtained from the leaf of *Artocarpus*. The conductivity of the petiole in this case is relatively feeble, and these normal responses, preceded by preliminary positive twitches, were obtained when stimulus was applied at a distance of

3 mm. from the responsive pulvinoid. I then repeated the experiment with the same leaf, but applying stimulus at the greater distance of 5 mm. The responses now consisted of a series of up movements of the leaf, indicative of positive turgidity-variations (fig. 170, *b*), the direct effect of stimulus not reaching the organ.

Now, turning our attention to the growing organ, we find that the fibro-vascular element, which possesses the power of conduction to a high degree, is not yet fully established in the zone of growth. If, then, contiguous to the growing zone there be a mass of active tissue thrown into a state of rhythmic excitation, it is to be expected that the indirect effect of such stimulation will alone act, and give rise in the region of growth to pulsations of increased turgidity. It will be remembered from the last chapter that water is conducted by preference along the fibro-vascular elements; and since these strands end below the zone of growth, it is clear that there must be in this region an accumulation of water, and consequent over-turgidity of the tissue; a condition which is, as we know, sufficient to initiate rhythmic excitation.¹ This region, then, acts like the actively excitable tissue of *Colocasia*, which, as we saw, gives rise to spasmodic expulsions of water. In the latter case there is, however, a channel by which the water escapes, thus relieving the pressure on the tissue; but the growing organ offers only a *cul de sac*, and the constant repetition of hydrostatic blows thus effects those positive turgidity-variations that are to result in the responsive elongations and incomplete recoveries of the tissue, bringing about growth-movements.

'Inner stimuli.'—It is thus seen that growth represents the indirect effect of stimulus; its motive power residing in the rhythmic activity of the internal tissues of the plant. This rhythmic activity has been shown to be, in its turn, the result of the tonic condition of the plant, that is to say, of the sum total of energy previously absorbed, and held

¹ Or the over-turgidity of the growing region may be sufficient of itself to initiate rhythmic activity.

latent in the tissue (p. 314), which we have designated as **the internal energy**. We have thus succeeded in defining the actual nature of those 'inner stimuli' to which the phenomenon of growth is usually vaguely ascribed.

From what has been said, it is clear that the responsive peculiarities of the growing region are not *per se* in any way different from those of any other excitable tissue, the apparent contrast between negative and positive turgidity-variations—that is to say, between responsive contractions and responsive expansions—having been shown to depend upon the fact that in one case we see the direct, and in the other the indirect, effects of excitation. If this be so, it follows that the *direct* application of external stimulus to a growing tissue ought to have the normal effect of excitatory contraction. In other words, while the action of the so-called 'inner stimuli,' or internal energy, gives rise, as explained above, to responsive expansions, the direct effect of external local stimulation must be the production of responsive contractions. That this is the case, will be shown in the next chapter.

SUMMARY

Growth is a phenomenon of multiple response.

Each of these multiple growth-responses consists of a sudden elongation, due to a pulse of increased turgidity, followed by an incomplete recovery. The difference between elongation and recovery is the irreversible growth-effect.

Such responses, when very rapid, appear as continuous.

In ordinary excitatory response there is a pulse of diminished, and in growth-response a pulse of increased, turgidity. Both are, however, effects of excitatory reaction.

When a tissue is locally excited, it gives a response of negative turgidity-variation, that is to say, of contraction. This is the direct effect of stimulus.

When the source of stimulation is behind, and the intervening tissue does not conduct excitation, then the excitatory expulsion of water finds expression in a positive turgidity-

variation, which produces an expansion of the responding zone of growth. The growth-response is thus the indirect effect of stimulation.

The rhythmic activity of internal tissue supplies its motive power to the zone of growth. This activity, depending on the tonic condition of the plant, constitutes the 'inner stimuli' to which growth is to be ascribed.

CHAPTER XXXII

THE EFFECTS ON GROWTH OF INTERNAL ENERGY AND EXTERNAL STIMULUS

Characteristics common to growth and to other forms of rhythmic response :

- (1) Periodic groupings—(2) Effect of external stimulus in renewal of growth when at temporary standstill—(3) Renewal of growth-pulsation by positive turgidity-variation—(4) Effect of increased internal hydrostatic pressure—(5) Effect of ascent of sap on growth—Effect of temperature on growth—Comparison of various types of multiple response—Effect of external tension on growth—Effect of direct application of stimulus on the growing region—Similarities between motile and growth responses—Direct and indirect effects of stimulus, and laws of growth.

HAVING shown in the last chapter that growth is a form of multiple or rhythmic response, I shall now proceed to demonstrate in detail the fact that in it also are found various phenomena which are characteristic of rhythmic response in general.

(1) **Periodic groupings.**—In the multiple response of *Biophytum*, and in the autonomous response of *Desmodium*, we have noticed the occurrence of various periodic groupings, the simplest of which consisted of an alternate waxing and waning of the pulses. In multiple growth-responses, similarly, we are able to detect such groupings, of which the simplest was shown in fig. 169 (*c*). When a continuous series of records is taken, extending over some time, these groupings undergo various changes, as is illustrated in that figure, the three series (*a*), (*b*), and (*c*) having been taken with the same plant at different intervals. It will there be seen that the pulse-records in (*c*) represent an alternate waxing and waning of amplitude; that in those of (*b*) the responses are small at the beginning and large at the end; and, finally, that in the

responses of (a) this order is reversed, the amplitude being at first great, and undergoing a steady decrease to the end.

(2) **Effect of external stimulus on growth when at standstill.**—It will be remembered that the rhythmic excitation of *Desmodium* comes to a standstill under unfavourable circumstances—that is to say, when the sum total of internal energy has fallen below par; and when this has happened, the application of fresh external stimulus is found to renew the activity. Growth-response, similarly, comes to a stop when the plant is in an unfavourable

condition with regard to light, temperature, or moisture. I shall now show that under such circumstances the application of external stimulus is found to be competent to renew growth. Taking a specimen of the hypocotyl of *Tamarindus indicus*, in which growth had come to standstill, I stimulated the plant by thermal means, and this was found to renew the multiple response of growth, as is clearly seen in fig. 171. The pulses are here characterised by interesting periodic variations. The period of each is relatively long, the average value being about six minutes. In some other cases the renewed pulsations were so rapid as almost to

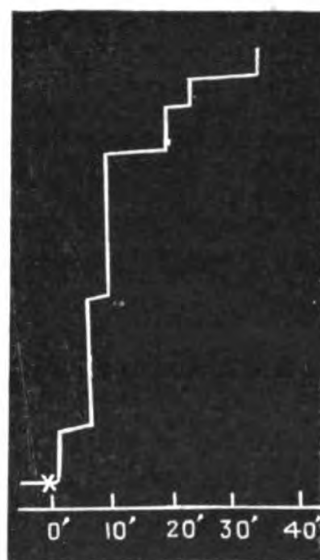

FIG. 171. Renewal of Growth-pulsation by Thermal Stimulus in *Tamarindus indicus* originally at Standstill

appear continuous. When the tonic condition of the plant was very low, the energy supplied by brief stimulation was only sufficient to maintain the rhythmic growth-activity for a short time, and after this the plant would again return to the state of standstill. It will thus be seen that when the tonic condition of the plant is below par, the applied external stimulus is absorbed, and, becoming latent, serves as internal energy for the production of growth-response (cf. p. 462). I shall adduce other instances of this in the course of the present chapter.

(3) **Renewal of growth by positive turgidity-variation.**—We have seen that in *Desmodium* in a state of standstill, increased internal hydrostatic pressure renewed the rhythmic

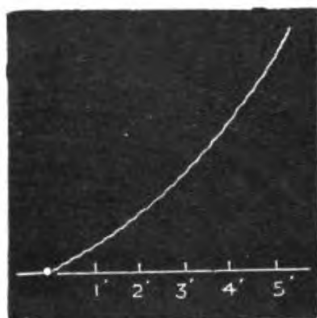

FIG. 172. Initiation of Erectile Response in leaf by Supply of Water to partially Drought-rigored *Mimosa*

activity. It was also stated in the last chapter, that growth is a responsive expression of the positive turgidity-variation. We have seen further that the mechanical expression of the positive turgidity-variation in a dorsiventral organ takes the form of erectile response. Thus this erectile response and growth-elongation are to be regarded as two different forms of expression of the same internal activity.

If we take for example a plant of *Mimosa* which is under-turgid, for want of sufficient supply of water, but not to the extent of drought-rigor, the leaves are found to assume a

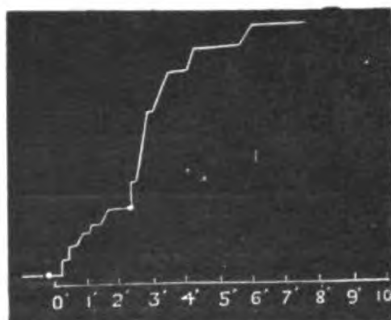

FIG. 173. Initiation of Growth-pulsation by Small Supply of Water to Drought-rigored Seedling of *Cucurbita*

The first thick dot represents application of water, which induces growth for three minutes only. A second application at the second dot renews it for the second time.

Cucurbita 12 cm. in height, growing in a small pot, which had come to growth-standstill for reasons described. Two cc. of water was supplied to the dry soil about the roots, and

certain horizontal position, corresponding to the degree of turgidity. If we now supply the plant with water, poured on at the roots, the consequent sudden increase of suctional pumping activity is seen in the positive erectile response of the leaf (fig. 172).

Similarly, when an ordinary plant, under the same circumstances, has its growth brought to a standstill, the growth-elongation is found to be renewed on the application of a fresh supply of water. This experiment was carried out on a seedling of

growth-response was initiated after a latent period of eleven seconds (fig. 173).

It will be remembered that the positive turgidity-variation, on which growth depends, is hydrostatically transmitted at a much quicker rate than the state of excitation itself. In the present case, the responsive elongation in the growing region at a distance of about 12 cm. took place eleven seconds after the application of water at the root. There was a certain loss of time before the cells in the growing region became of sufficient turgidity to initiate growth. The small supply of water which had been given was enough to maintain growth for three minutes only, after which the plant came again to a standstill. Another 2 cc. of water was now applied, and the latent period was found reduced, as we should have expected, being now three seconds only. This was due to the fact that the cells had not now to absorb water before they could be sufficiently turgid. This renewed growth-activity was again, however, exhausted after about three minutes; and it was very interesting to observe how the response of growth followed, for a little while, after each such doling out of water.

(4) **Effect of increased internal hydrostatic pressure.**— We found, in the case of *Desmodium*, when the cut petiole, carrying the motile leaflets, was subjected to increased hydrostatic pressure, applied by means of the U-tube, that the rhythmic activity of the leaflet, as shown by its quickening, was thereby increased (p. 320). We saw also in that case that this increased frequency, due to increased pressure, reached an optimum, and that beyond this, under excessive pressure, the pulsations became irregular, or even came to a stop.

In order, then, to study the effect of hydrostatic pressure on growth, I mounted the specimens—in this case an entire seedling of *Balsam* and a cut flower of *Crinum*—in U-tubes supplied with water, and proceeded to take records, first under normal conditions—*i.e.* the level of water in the two limbs being the same—and then under a gradually increasing hydrostatic pressure. These records are made, it should be said, only when the rate of growth under the changed

conditions has become uniform. This occurs, generally speaking, after a period of variation which does not exceed two or three minutes. I give here a table embodying the results of the experiments on *Balsam*, and on *Crinum*, which show how increase of internal hydrostatic pressure increases the rate of growth up to an optimum, after which there is a diminution of growth.

TABLE SHOWING EFFECT ON GROWTH OF INCREASED INTERNAL HYDROSTATIC PRESSURE

Balsam seedling		Crinum Lily	
Pressure	Rate of growth	Pressure	Rate of growth
Normal	·0034 mm. per minute	Normal	·0038 mm. per minute
5 cm.	·0036 " " "	10 cm.	·0044 " " "
10 cm.	·0060 " " "	20 cm.	·0142 " " "
15 cm.	·0095 " " "	30 cm.	·0036 " " "
20 cm.	·0130 " " "		

The curve seen in fig. 174 exhibits graphically the relation between these internal pressures and corresponding growths in the case of *Balsam* seedling. It will be seen that after a certain moderate rate of growth has been attained by increase of pressure, the curve becomes a straight line; that is to say, after this point, equal variation of pressure produces equal variation in the rate of growth. But in the first part of the curve, where the rate of growth is feeble, an equal increase of pressure causes a disproportionately large increase in the rate of growth. This is still more strikingly shown when the growth, to begin with, is zero—that is to say, at standstill; in such a case, by gradually increasing the internal pressure, we arrive at a point where growth begins abruptly, after which increasing pressure causes an increasing rate of growth. But if the pressure be now brought back to a point just below that at which growth was initiated, it is found not to be arrested, but to persist. Thus the curve does not here return upon itself.

Since the various growth-curvatures are brought about by the variations of internal hydrostatic pressure caused by the

action of external stimulus, this quantitative demonstration of the effect of internal pressure on growth, is of much theoretical importance.

I have already shown the connection between mechanical response and growth-response, and demonstrated the fact that the erectile mechanical response and growth-elongation are but different expressions of increased internal activity. I shall now show how the suctional and growth responses are related to each other, and in what manner the action of the former affects the latter.

(5) **Effect of ascent of sap on growth.**—We have already seen that the positive turgidity-variation on which growth depends is brought about, under normal conditions, by the ascent of sap. As regards the latter, we have seen that when the root is subjected to the stimulating action of warm water there is a sudden augmentation induced in the rate of suction. The application of cold water, on the other hand, induces the converse effect. The mechanical response of the plant to warm or cold water, applied at the base, was shown to be manifested in the erection or depression of the leaves of *Mimosa* or *Biophytum* (p. 400).

These agents are seen in the following experiments to produce parallel effects on growth. A growing *Crinum* Lily was taken, and its normal rate of growth ascertained to be .005 mm. per minute. Ice-cold water was now applied at its base, and this was found to cause an almost immediate arrest of growth. As the temperature, however, was gradually restored to that of the surroundings, the rate of growth was also slowly recovered. Five minutes after, the rate was only

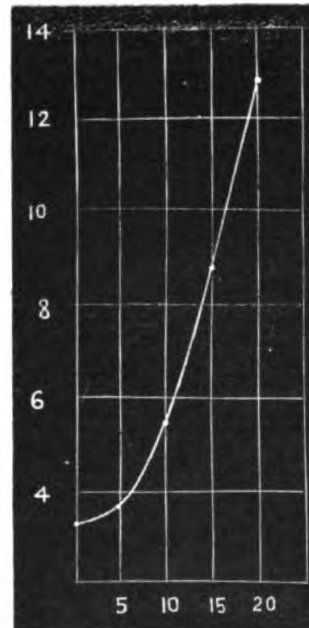

FIG. 174. Curve showing Relation between Internal Hydrostatic Pressure and Rate of Growth (*Crinum* Lily)

001 mm. per minute, or one-fifth of the original rate. It was only after about half an hour that the original rate of growth was once more attained.

I next applied warm water at the base, with the result that the rate of growth was almost instantaneously enhanced to 125 mm. per minute, or twenty-five times the normal! That this effect was not due to the rise of temperature as such, is shown by the fact that it was almost instantaneous, and that, moreover, as will be shown in the next chapter, the maximum rate of growth of *Crinum* at the optimum temperature is only about three or four times as great as the normal.

From these experiments we see that the energy applied at the root is transmitted hydraulically to the growing region by the ascent of sap, where a certain amount of work is performed in causing an increase of turgidity, and thus producing in the cells a state of tension. Growth is now caused not simply by the presence of water, but rather by the energy conveyed by that water. It is well to bear in mind, at this point, that the mobility or plasticity of the responding growing region is also an important factor in the production of growth; for if the molecular mobility of the zone of growth be in any way reduced, the transmitted pressure, which was formerly effective, will now become ineffective to bring about growth.

(6) **Effect of temperature on growth.**—We have seen, in studying the pulsatory movements of *Desmodium*, that the rise of temperature, within certain moderate limits, increased the rhythmic activity of the plant, as shown in the increased frequency of pulsation. At a maximum temperature, again, above 40° C. these movements almost disappeared, there being now produced very rapid oscillations, of so small an amplitude as to be almost incapable of detection. This will be seen in fig. 175, where the normal pulsations, of a period of 2.5' at 30° C., are seen reduced to a period of only 10" at 42° C. With this, the amplitude also is so far reduced as to be visible only on very careful inspection. We meet with

corresponding phenomena in growth-response. It will be shown in the next chapter that the rate of growth increases with the rise of the temperature up to a certain optimum. At a determinate maximum, however, which is about 44° C., growth is arrested, but this arrest does not, as we have just seen in the corresponding instance of *Desmodium*, imply a total cessation of internal activity. In making experiments on a seedling of *Balsam*, I obtained the record shown in the upper part of fig. 176, the temperature being 34° C., which is below the optimum. The average period of a single pulse

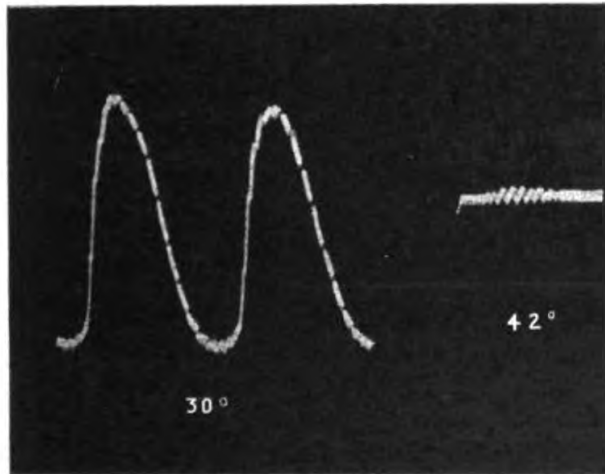

FIG. 175. Photographic Record showing the Slow Pulsations of Large Amplitude of *Desmodium* Leaflet at 30° C. to become very much Quickened and Reduced in Amplitude at 42° C.

was in this case 12.5 seconds, and owing to the considerable amplitude of each pulsation, combined with its incomplete recovery, the average of the resultant rate of growth was as much as .074 mm. per minute.

On now raising the temperature to 44° C. I obtained the lower of the two records in fig. 176, showing no resultant growth. It is interesting to observe the process by which the cessation of growth comes about in this case. For it is clearly seen from the record that there is no cessation of activity. On the contrary, we find that the frequency of oscillation has become increased from four pulsations to ten,

in the course of 50". The average period has thus fallen from 12.5" at 34° C. to 5" at 44° C. The amplitude of pulsation at the same time is found to be decreased, and this,

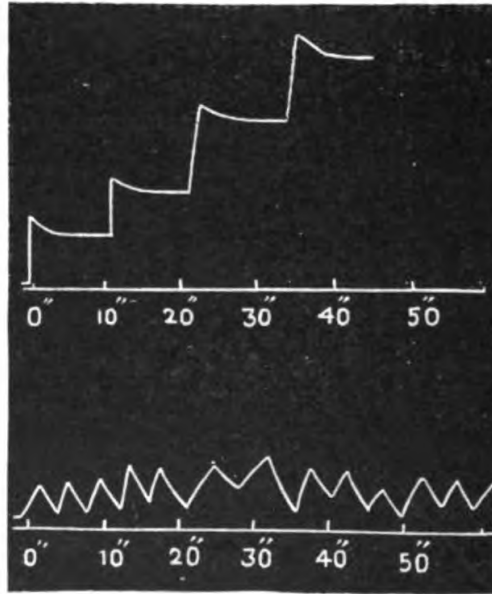

FIG. 176. Growth-pulsation seen in Seedling of *Balsam*

Upper record shows slow pulsations with incomplete recoveries at 34° C. Lower record shows quickened pulsations with complete recoveries at 44° C. The magnification employed is 500 times.

with the fact that recovery is now complete, accounts for the resultant cessation of growth.

Comparison of various types of multiple response.—At this point, it is worth while to compare two or three types of multiple response. In *Biophytum* we have seen that, by reason of incomplete recoveries from *negative* turgidity-variation, the multiply-responding leaflet gradually becomes depressed below its original level. In contrast to this we have in growth-response those incomplete recoveries from *positive*

turgidity-variations which have the effect of gradual elongations. In the pulsation of *Desmodium* again we have an intermediate instance where, response and recovery being equal, the responding organ is ultimately neither raised nor depressed. It is interesting to note, therefore, that in raising the temperature of a growing organ to the maximum, and thus abolishing the resultant elongation, we bring on a condition of equality of response and recovery which in so far resembles the pulsation of *Desmodium*.

Effect of external tension on growth.—Great advantages are afforded by the method of magnified record, which enables us to detect instantly the immediate and after effects on the specimen of any changes of external conditions. It is

thus easy to obtain exact records of the effect of tension on growth. The normal record is first taken, with the very slight tension exerted by the recording lever itself. The short arm of the lever, .5 cm. in length, is, it should be remembered, attached to the growing organ. A rider, half a gramme in weight, can be placed on the longer arm of the lever, at distances of .5, 1, 1.5, 2, 2.5, or 3 cm. from the fulcrum. The effective tension may thus be gradually increased, and the corresponding effects on growth recorded. It may be stated here that, generally speaking, any sudden change of external conditions, such as sudden cooling, sudden warming, or sudden variation of tension, acts on the organ as an external stimulus; and I shall presently show that an external stimulus always induces a contraction or retardation of growth. When the organ is subjected to sudden increase of tension, the preliminary effect of contraction occurs therefore, as we should expect. But after this temporary disturbance has disappeared we are able to observe the permanent effect of increase of tension on growth. For these experiments I took different specimens of *Crinum* Lily, and the results obtained show that increase of tension enhances the rate of growth. This increase, however, appears to reach a limit at a certain optimum point, beyond which increase of tension would seem to retard growth. The following table exhibits the results of two experiments on different specimens of *Crinum*.

TABLE SHOWING EFFECT OF TENSION ON RATE OF GROWTH

Specimen A		Specimen B	
Tension	Rate of growth	Tension	Rate of growth
Weight of lever alone	mm. '0040 per min.	Weight of lever	mm. '0036 per min.
1 gr. + lever	'0110 " "	.5 gr. + "	'0070 " "
2 gr. + "	'0140 " "	1 gr. + "	'0100 " "
3 gr. + "	'0045 " "	1.5 gr. + "	'0130 " "
		2 gr. + "	'0170 " "
		2.5 gr. + "	'0050 " "

F F

Effect of direct application of stimulus on the growing region.—Many of the phenomena of growth-curvature are brought about, as we shall see, by means of the changes induced by external stimulus in the rate of growth, and there is much misconception as to whether the effect of stimulus is to enhance or to retard growth. I shall be able to show that this misconception is the result of the complexity of the problem, depending (1) on the tonic condition of the tissue, (2) on whether the stimulus is internal or external, and (3) on the point of application of stimulus. The fundamental effect of stimulus is, however, very definite.

But at the beginning of our investigation we are met by a question of great importance, namely, as to whether the effect

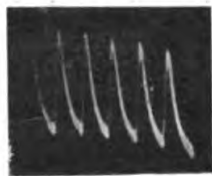

FIG. 177. Photographic Record of Responses of Mature Style of *Datura alba* to External Thermal Stimulus

of stimulus on a growing, is in any way different from that on a stationary organ. We have seen, for example, that a fully grown style of *Datura*, in which growth has come to a stop, exhibits on the application of local stimulus the usual contractile response (fig. 177). On the completion of recovery again, the organ returns to its original length. Hence the base-line of a series of these responses is horizontal.

I shall now pass, by means of intermediate links, from this to the response of growing organs. And first I shall take the response of a style of *Datura*, in which, for want of a sufficient supply of internal energy, growth has come to a temporary stop. On applying thermal stimulus, at intervals of a minute, the first five responses are seen to be practically like those of the stationary style of *Datura* (fig. 178, cf. 177). But a portion of the stimulus applied is being absorbed and held latent in the organ, thus increasing the internal energy, or tonic condition. The result of this is seen in the renewal of growth at the sixth response. The stimulus now, therefore, finds bifurcated expression in maintaining response, and in renewing growth, as is seen by the trend downwards of the

hitherto horizontal base-line. This bifurcation causes the first contractile response of the now growing organ—that is the sixth response of the record—to be smaller than usual. But as the tonic condition is established, and the molecular mobility of the responding organ is increased, the contractile response becomes larger, and growth goes on at a certain steady rate. From this intermediate link we pass on to the case of response to stimulus of a style of *Datura* which is in a state of uniform growth (fig. 179). Here also we find that stimulus produces the normal contractile effect. All these clearly demonstrate that the response of growing organs is in no way different from that of stationary organs. In a stationary organ, stimulation produces negative turgidity-variation, resulting in contraction. The same contraction is seen in growing organs, causing a temporary retardation of the rate of growth.

The retardation of growth which is caused in a growing organ by external stimulus may be exhibited in a somewhat different way. We may use the Method of Balanced Record, by which the normal rate of growth is made to appear as a neutral horizontal line. For the purpose of this experiment I took the growing peduncle of a *Eucharis* Lily. The balanced record (fig. 180) is here seen to be horizontal, save for minute autonomous oscillations about the neutral line. Stimulation, in this case, was produced by tetanic electric shocks from an induction coil, which were applied on the growing

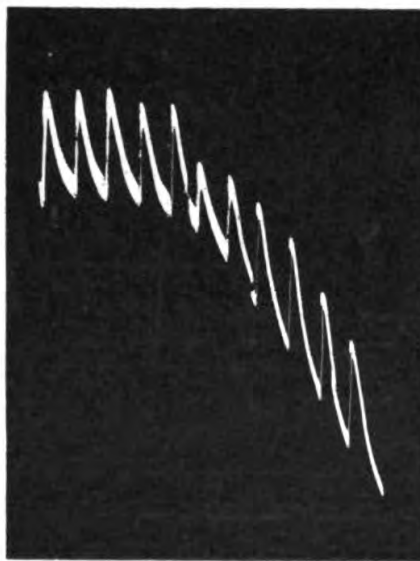

FIG. 178. Photographic Record of Responses of Style of *Datura alba* in which Growth had come to a Temporary Stop

The up curve shows contraction. As long as the base-line is horizontal, growth is seen to be at standstill. Renewal of growth at sixth response, after which growth-elongation is shown by the trend of the base-line downwards.

organ, by means of non-polarisable electrodes, connected, one a little above, and the other a little below, the growing region. According to the conditions of the experiment, the balanced horizontal base-line will represent uniform growth

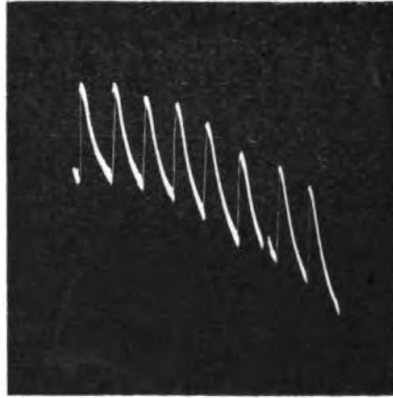

FIG. 179. Photographic Record of Response of Growing Style of *Datura alba* to External Stimulus

under normal turgidity. An up curve will here represent a rate of growth below the normal, or a retardation; a down curve, on the contrary, will represent a rate of growth above the normal, or an acceleration. When stimulus is applied a responsive negative turgidity-variation is induced, in consequence of which there is a temporary disturbance of the balanced growth-record. The curve thus produced exhibits

the effect of stimulus, and recovery from that effect. It will be observed from the figure that on the application of tetanic electric shocks for two seconds, a responsive retardation of

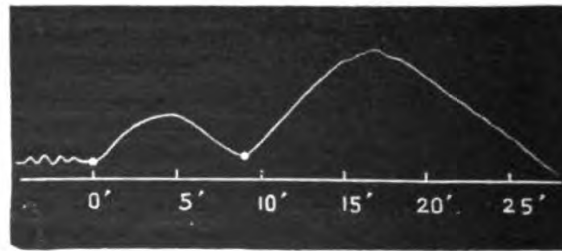

FIG. 180. Balanced Record of Response in Growing Peduncle of *Eucharis Lily* to Electrical Stimulation

Up curve here represents retardation of growth. First response is to stimulus of two seconds', the second to stimulus of three seconds', duration.

growth was induced, as seen in the up curve, and that there was a recovery after an interval of nine minutes from the time of application of stimulus. It will also be noticed that during the process of recovery in this particular case, the rate

of growth is above the normal, which is due to the fact that the internal energy has been augmented by the absorption of the stimulus applied.¹ A stimulus of longer duration, that is to say of three seconds, was next applied, and the responsive retardation had now a greater amplitude than before, the period of restoration being also longer, that is to say, sixteen minutes.

Similarities between motile and growth responses.—

We have, then, in growth-response an exact parallel to the mechanical responses given by pulvinated or anisotropic organs. The following tabular statement will show the reason of this fundamental parallelism between responses whose modes of indication are so widely different :

TABULAR STATEMENT SHOWING COMPARATIVE EFFECTS OF STIMULUS IN PULVINATED AND GROWING ORGANS

Mechanical response	Growth response
<i>Effect of normal turgidity :</i> Normal horizontal position of leaf.	<i>Effect of normal turgidity :</i> Uniform rate of growth.
<i>Local action of external stimulus :</i> Contraction ; Diminution of turgidity ; and concomitant depression of leaf.	<i>Local act.on of external stimulus :</i> Contraction ; Diminution of turgidity ; and concomitant depression of rate of growth.
<i>Action of internal energy exhibited by</i> (a) Recovery : Re-establishment of turgidity and gradual return of leaf to normal horizontal position. (b) Increased hydrostatic pressure : Erection of leaf.	<i>Action of internal energy exhibited by</i> (a) Recovery : Re-establishment of turgidity and gradual return of organ to normal rate of growth. (b) Increased hydrostatic pressure : Increased rate of growth.

In studying the mechanical response of plants we found that direct application of stimulus to the responding organ always produced a response characterised by the negative turgidity-variation, that is to say, a depression of the leaf. We also saw that internal energy, inducing positive turgidity-variation, caused the opposite response, that is to say, an erection of the leaf ; and that an increase of the internal energy

¹ Other records showing the effect of external stimulus on growth will be found in Chapter XXXIV.

of the organ was, in some cases, brought about by that increased suctional activity by which energy was transmitted, by means of water forced into the responding organ. This increased suctional activity was due in its turn to external stimulation of the roots. Or a similar transmission of energy to the responding organ might be the result of stimulation applied at a distance on the stem, in consequence of which a wave of positive turgidity-variation would travel towards the responding organ from the excited point. For the exhibition of this latter effect, however, it is necessary that the *direct* excitatory effect of stimulation should not be conducted to the organ. This condition is met if the point of stimulation be at a sufficient distance, or when the intervening tissue is not a good conductor of excitation. Again, the plant as a whole, it must be remembered, has its internal energy raised, as the after-effect of the absorption of stimulus from its surroundings.

Direct and indirect effects of stimulus and laws of growth.—In the phenomenon of growth-response we have a case which is exactly parallel. Direct stimulation of a growing organ always induces a negative turgidity-variation, with a concomitant responsive retardation of growth. Anything, on the other hand, which increases the internal energy, brings about the opposite effect, of positive turgidity-variation, with concomitant responsive increase in the rate of growth. This may be induced by a favourable rise of temperature, or by stimulating the root, and so increasing the ascent of sap. It may also be brought about by stimulating a distant point, and so causing a wave of positive turgidity-variation to be transmitted to the responding organ, the stimulated point being at a sufficient distance to prevent the direct effect of stimulus from reaching it. And, finally, the energy absorbed from external stimulus may, as an after-effect, increase the internal energy of the plant. The increase of internal energy, under all these different conditions, we shall for the sake of convenience designate as the **INDIRECT EFFECT OF STIMULUS**.

The laws of growth are therefore :

(1) **The response of a growing organ is the same as that of a stationary organ. Direct application of stimulus, inducing contraction, retards the rate of growth.**

(2) **The effect of indirect stimulation is to increase the internal energy, and thus augment the rate of growth.**

SUMMARY

The multiple response of growth is characterised by all the peculiarities seen, for instance, in the autonomous response of *Desmodium*.

The rhythmic responses of growth exhibit periodic groupings.

External stimulus is found to renew growth in organs in which, owing to the deficit of internal energy, it had come to a temporary standstill.

The increase of internal hydrostatic pressure, up to an optimum, increases the rate of growth.

The effect of increased internal hydrostatic pressure is exhibited in the case of the leaf of *Mimosa* by an erectile response. In a growing organ the effect of increased turgidity is shown by growth-elongation. A drought-rigored *Mimosa* on being supplied with water responds by erection of the leaf ; and similarly, a plant in which growth, owing to drought-rigor, has come to a standstill, responds, on being supplied with water, by renewed growth-elongation. When the root of *Mimosa* is supplied with ice-cold water, the responding leaf, owing to the consequent arrest of ascent of sap, becomes depressed. The increased suctional activity, again, which is caused by a supply of warm water to the root, induces an erectile response of the leaf. Similarly, corresponding variations in the rate of ascent of sap, brought about in a growing plant by the application of cold and warm water to the roots, cause respective depressions and accelerations of the rate of growth.

The energy supplied at the roots is hydraulically trans-

mitted to the growing region, and finds expression in the work of growth.

A rise of temperature, up to the optimum, enhances the rate of growth. At a maximum temperature of about 44° C. growth is apparently arrested. This is not, however, due to any rigor or arrest of internal activity, but to the fact that in each pulsation of growth the constituent response and recovery are now equal. There is thus no resultant growth-elongation. At such a temperature the amplitude of pulsation is reduced, and the frequency increased, as in *Desmodium*.

Longitudinal tension has the effect, up to an optimum, of increasing the rate of growth.

The effect of external stimulus on a growing, is precisely the same as on a stationary, organ, that is to say, a responsive contraction. On account of this contraction, and concomitant negative turgidity-variation, growth is retarded, as the direct effect of the action of external stimulus.

External stimulus, however, when absorbed and held latent by the tissue, has the effect of increasing the internal energy of the plant. This indirect effect of stimulus causes acceleration of growth.

CHAPTER XXXIII

ON THE RELATION BETWEEN TEMPERATURE AND GROWTH, AND THE ACCURATE DETERMINATION OF OPTIMUM AND MAXIMUM POINTS

General consideration of difficulties of accurate determination of effects of temperature on growth—Four accurate methods: (1) Method of discontinuous observations—Accurate regulation of temperature by electrolytic rheostat—(2) Method of continuous observations—Thermo-crescent curve—Determination of the optimum point—(3) Method of balance—(4) Method of excitatory response—Translocation of the optimum point.

DETERMINATIONS of the effect of temperature on growth are usually carried out either by observing a single plant for several hours in succession, or by obtaining the average growth of various groups of plants, kept under different temperatures. In the latter case the individual peculiarities of different specimens cause them to give values which are more or less discrepant, but this fact is to some extent neutralised by taking the average of a large number. These methods, however, are all very laborious, and the results not highly consistent. Whichever method be adopted, we have to remember that in all cases in which observations stretching over periods of several hours are required, the growth of the plant will be liable to spontaneous variations, resulting from the periodicities impressed upon it by the changing conditions of its environment. It is, perhaps, owing to this fact that the results obtained by various authorities have been so widely divergent. For example, the optimum temperature for growth of *Zea mais* was found by Sachs to be 34° C. and by Koppen to be 30.2° C.

Clearly, the perfect method would be one in which we should be able to measure the effects of temperature alone on

the growth of a particular plant, so that the varying factors of age and constitution, or tonic condition, should remain constant. And, further, it should be possible to carry out this determination of growth at different temperatures in a time so short that the spontaneous variations of the plant, if any, would be insignificant. Only by such a method could we hope to obtain results which would be reliable and consistent.

Keeping these considerations in view, I have been fortunate enough to be able to devise four distinct methods of determining the effect of temperature on the rate of growth, the perfection of which may be gauged from the fact that the results of all agree with and corroborate each other within a fraction of a degree. With some of these, the entire experiment on the different rates of growth at various temperatures, ranging from ordinary through optimum to maximum, can be carried out within about half an hour. The determination of any single cardinal point, such as the optimum, can always again be made within five minutes. The investigation thus gains by simplicity and experimental accuracy, and observations may be made on many different specimens within a very short period. I shall now proceed to describe these different methods.

(1) **The method of discontinuous observations.**—We shall first take the method by which rates of growth are recorded at different temperatures, say one degree apart. Some means of raising the temperature to exactly the required point, and maintaining it unchanged during the time of experiment, is an essential condition of all these investigations. This I have been able to accomplish in the following way. The electrical heating coil inside the plant chamber is put in connection with an external battery. The heat given out, and the consequent permanent rise of temperature in the chamber, depend on the intensity of the current that flows through the heating coil. This current again may be progressively regulated by the interposition of an electrolytic rheostat in the circuit, the resistance of which

can be subjected to gradual variation. The electrolytic rheostat consists of two semicircular troughs (fig. 181). By turning the handle, say to the right, the electrolytic resistance interposed is continuously increased, diminishing the current, and hence diminishing the temperature inside the chamber. Rotation of the handle in the opposite direction produces the opposite effect, that is to say, raises the temperature inside the chamber. Thus, by proper manipulation of the handle of the rheostat, the chamber can be raised to any temperature,

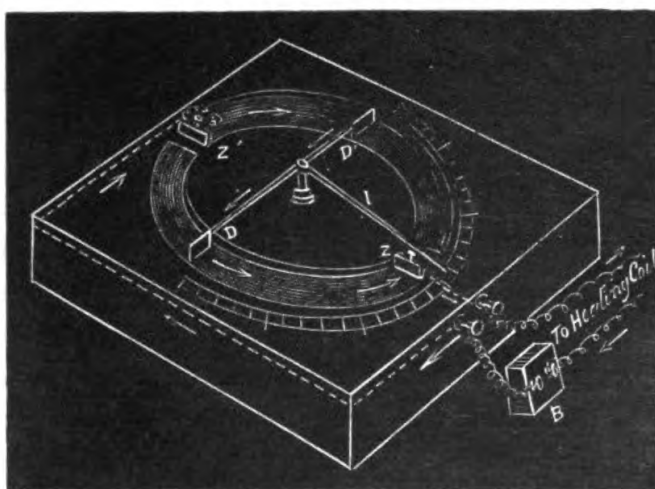

FIG. 181. Semicircular Electrolytic Rheostat interposed in Heating Coil

Current enters the first trough, filled with zinc sulphate solution, by the electrode, z' , and is led to the second trough by the diagonal metallic connector, $D D'$. By turning the index-arm, I , clockwise, the interposed resistance is increased, and the heating current thus diminished. Rotation in the opposite direction diminishes the resistance and increases the heating current.

which can then be maintained uniform for any length of time, by keeping the rheostatic resistance constant. From a previous experiment, the temperature-values of the position of the index in connection with the handle can be ascertained and marked. Thus by turning the handle to any given index number, say of 31° C., the temperature of the chamber will be found to be raised permanently to that value. A delicate thermometer graduated in twentieths of degrees is placed in the chamber, and affords an independent indication of the

temperature thus attained. It is also necessary, for reasons to be fully explained in a subsequent chapter, that the specimen should not receive thermal radiation from the heating coil, as such radiation, I find, retards growth. A shield of mica, opaque to thermal radiation, is interposed between the heating coil and the plant, which is thus subjected only to the action of changes of temperature. For many of my experiments I selected specimens of the *Crinum* Lily, on account of its extreme regularity of growth, which is so uniform that on adjusting the record under balance, the external conditions being constant, the line of record remained horizontal for a period of certainly over an hour.

The rate of growth at the temperature of the room, say 30° C., is first taken on the recording drum, which is covered with paper divided into millimetres. The horizontal distance or abscissa represents time, which, with the particular speed of drum which I used was 6 mm. per minute. The ordinate represents growth-elongation, and as the growth-recorder, or crescograph, produces a magnification of 1,000 times, 1 mm. distance of the ordinate is equal to an actual growth of $\cdot 001$ mm. The ordinate corresponding to an abscissa of 6 mm. would thus be equivalent to a growth in thousandths of a millimetre per minute.

The rheostat handle is now turned to the index-number corresponding to the raising of the temperature of the chamber by 1° C. There is first a variable period of rise of temperature, after which a permanent degree is attained. During this preliminary stage, *variation* of temperature acts as a stimulus, giving rise to responsive contraction or retardation of growth. But after this transient disturbance, the growth attains a constant rate, characteristic of the given temperature. These peculiarities will be better understood on following the record given in fig. 182—reduced here to half the original size—which was taken with a specimen of *Crinum* Lily, during ten minutes. The record during the first five minutes is for the temperature of 34° C. It will be seen that in two minutes the growth-elongation is fifteen divisions, and as each division

represents $\cdot 001$ mm., the rate of growth is thus $\cdot 0075$ mm. per minute. The rheostatic handle was afterwards turned to the mark 35° C. With the particular battery power used in this case, the permanent rate of rise to 35° C. was attained after a period of three minutes. It will be seen from the record that the stimulus of sudden variation of temperature caused a contractile twitch, after which growth proceeded at a very rapid rate during the variable period. But as soon as the temperature of the chamber had attained a permanent condition—*i.e.* 35° C.—the rate of growth became constant. The attainment of this constant rate was practically simultaneous with the attainment of the permanent temperature condition. The lag, in any case, if it existed, could not be more than fifteen seconds.

One curious and interesting fact to be fully explained later, which was noticed in the course of the experiments, was that the amount of contractile twitch went on increasing during the variable period, as the temperature was raised each time 1° C., from 30° to 35° C., but after this point practically disappeared. The permanent rate of growth, then, at a temperature of 35° C., is, as will be seen from the figure, twenty-four divisions per two minutes, or $\cdot 012$ mm. per minute. In this way, by taking successive records at different temperatures, I obtained the following rates of growth, in the cases of *Crinum* Lily and the peduncle of *Crocus*.

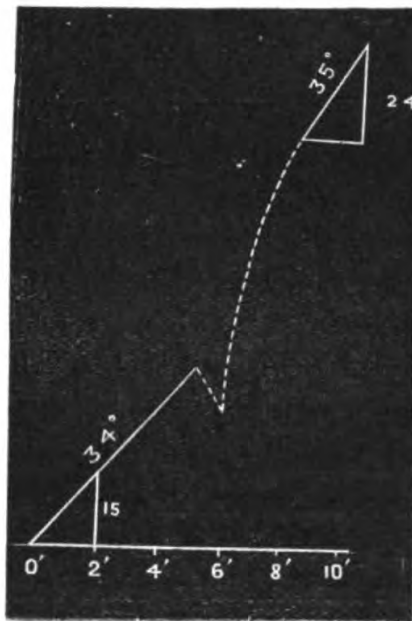

FIG. 182. Record of Growth in *Crinum* at Temperature of 34° C. and 35° C.

The dotted line represents the variable period of temperature change. Note the contractile twitch and transient highly accelerated growth which follows. The rate of growth became constant when the temperature became permanent at 35° C.

Crinum Lily		Peduncle of <i>Crocus</i>	
Temperature	Growth in mm. per minute	Temperature	Growth in mm. per minute
30° C.	·0036	30° C.	·0059
31° C.	·0040	33° C.	·0100
32° C.	·0050	35° C.	·0145
33° C.	·0055	36° C.	·0062
34° C.	·0075	38° C.	·0030
35° C.	·0085	40° C.	·0010
36° C.	·0050		
37° C.	·0035		

(2) **Method of continuous observations.**—The method which I have just described gives us results which, though obtained at closely consecutive temperatures, are nevertheless discontinuous. There is, besides, some loss of time involved during the variable period, in addition to which there is the factor of transient stimulation during sudden changes of temperature. For these reasons I was anxious to perfect some method by which the curve of growth should afford a continuous means of obtaining the rate of growth at all temperatures. I also wished to eliminate from this record the preliminary disturbance caused by sudden change of temperature.

I was enabled to do this in practice by bringing about a gradual and continuous rise of temperature, instead of the former sudden variations by steps. This was effected by turning the handle of the electrolytic rheostat at a rate so graduated that the rise of temperature within the chamber was uniform. As it was necessary to complete the experiment within not too long a period, I found that a rise of 1° C. per 2·5 minutes was sufficient to meet the requirements of the case. This means a rise of ·1° C. in fifteen seconds. An observer watches a delicate thermometer, which is placed in the plant chamber, with his hand on the handle of the rheostat. By means of this, and a chronometer beating seconds, he is able to regulate the uniform rise of temperature with the greatest nicety. Should the rate be too quick, it may be reduced by the slightest turn of the handle towards the increase of

resistance, or *vice versa*. After a little practice the process of regulation becomes almost instinctive. The record of growth is now taken continuously on the revolving drum, and the thermo-crescent curve obtained under these conditions of continuous variation of temperature is seen to be extremely regular, giving data by which we may determine the rate of growth at any point of the curve (fig. 183). The revolving drum gave, as already said, a movement of the recording surface of 6 mm. per

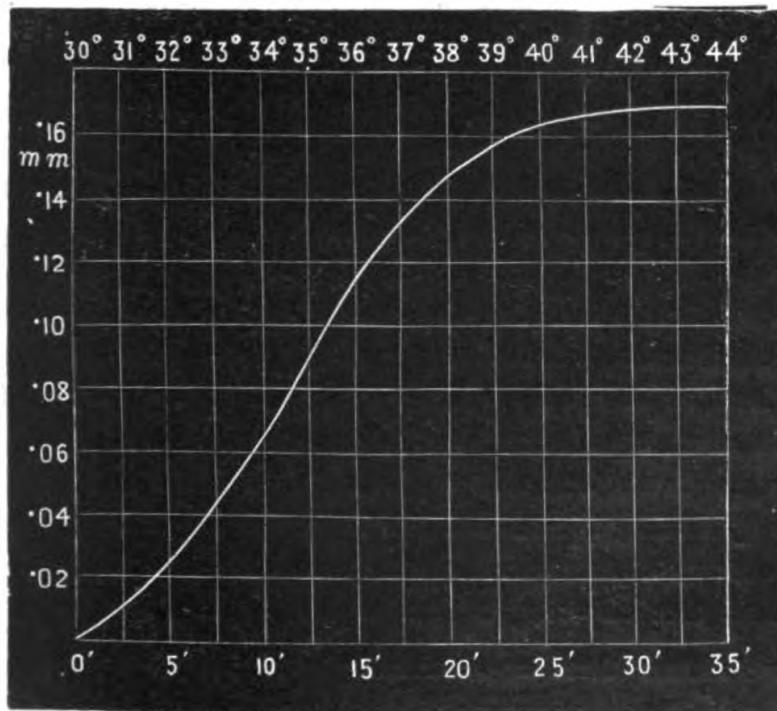

FIG. 183. Thermo-crescent Curve of Growth in *Crinum* Lily under Continuously Increasing Temperature

minute. That length of the abscissa would therefore represent one minute of time; and since the rise of temperature was regulated, at 1° C. of rise per 2.5 minutes, intervals of 15 mm. in the abscissa also represent 1° C. in temperature. With the magnification used, 1 mm. of the ordinate represents a growth-elongation of a thousandth part of a mm. In order, therefore, to obtain from this curve the rate of growth at any given temperature, say at 34° C., we have to find the elonga-

tion per minute at that point. The rise of temperature in one minute, then, under the experimental conditions described, is through 4° C. The growth-elongation of the specimen, therefore, while the temperature is rising from 33.8° C. to 34.2° C., gives us the rate of growth for the mean temperature of 34° C. This is found in the magnified record to be 10 mm. The absolute value of the rate of growth is thus $.01$ mm. per minute. In this way we can determine from the curve the rate of growth corresponding to any temperature. It will thus be seen how in the course of an experiment lasting for thirty-five minutes only, we are able to obtain data which give us the various rates of growth through a wide range of temperatures.

This operation can, moreover, be made entirely automatic. The breadth of the circular electrolytic trough may be appropriately varied at different parts of the circle, so that turning the handle through equal arcs raises the temperature of the plant chamber by equal degrees. The handle of the rheostat may then be rotated by the recording drum itself. Hence in the record, equal lengths of the abscissa will represent not only equal times, but also equal rises of temperature. And finally by taking the record photographically, the whole process becomes automatic. From the data furnished by fig. 184 we obtain the following table :

TABLE SHOWING RATES OF GROWTH AT DIFFERENT TEMPERATURES IN FLOWER OF CRINUM LILY.

Temperature	Growth in mm. per minute	Temperature	Growth in mm. per minute
30° C.	$.0040$	36° C.	$.0070$
31° C.	$.0057$	37° C.	$.0045$
32° C.	$.0075$	38° C.	$.0030$
33° C.	$.0087$	39° C.	$.0020$
34° C.	$.0100$	40° C.	$.0012$
35° C.	$.0110$	42° C.	$.0005$
35.5° C.	$.0113$	43° C.	$.0002$

The curve shown in fig. 184 exhibits the relation between these various temperatures and their corresponding rates of growth. It is here seen that the rate gradually rises till we

approach the optimum point, which in the present case is 35.5°C . After this there is a steep fall, and growth is almost abolished at a maximum temperature at or near 45°C . This arrest of growth does not mean arrest of internal activity. I have in the last chapter (fig. 176) explained why, in spite of the persistence of internal activity, there is in this case no resultant growth. It is to be borne in mind that as the curve of growth in fig. 183 is continuous, the rate of growth at

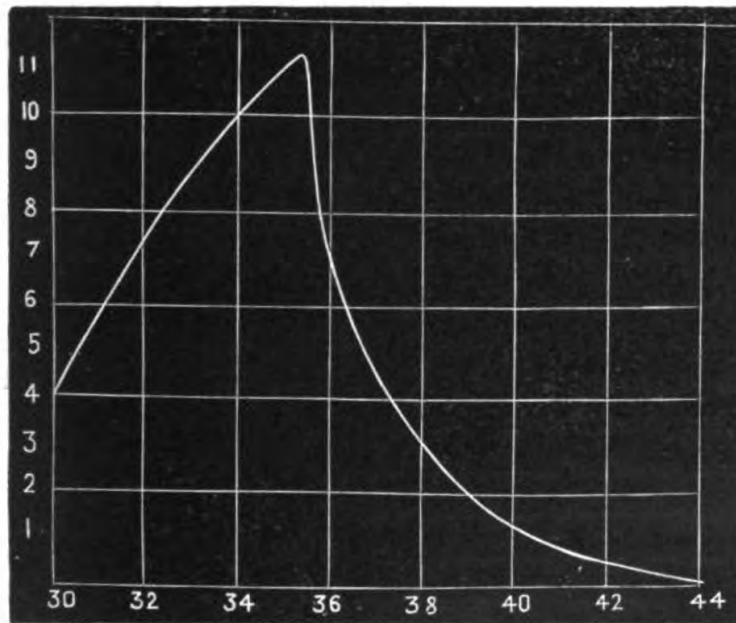

FIG. 184. Curve showing Relation between Temperature and Rate of Growth, as deduced from the Thermo-crescent Curve in fig. 181

points intermediate to those specified may be determined from it.

From a large number of experiments which I have carried out on *Crinum* Lily, I find that the optimum temperature is very constant, not varying by as much as one-tenth of a degree from the mean value of 35.5°C . as the optimum temperature. In the first portion of the curve, as the temperature rises from 30°C . to 35.5°C . the rate of growth is seen to increase, from '004 to '01125 mm. per minute, or to nearly three times its first value. The fall, beyond the optimum, is steeper than this rise. At 37°C . the rate of growth has

G G

fallen to 0.045 mm. per minute, or almost the same as at 30° C. Thus, while 5.5° C. of rise of temperature before the optimum enhanced the rate of growth by three times, a further rise of only 1.5° C. beyond that point was sufficient to bring it back to almost the same value as at 30° C. The individual characteristics of each specimen are seen, not by any perceptible variation of the optimum point, but rather by differences in the steepness, during rise or fall, of the curve. With some specimens, for example, the increase of rate of growth during an equal rise of temperature from 30° C. to 35.5° C. is only half of that seen in the figure. The steepness of fall, on the other hand, beyond the optimum may be much greater; that is to say, a rise of 1° C. or less above the optimum will sometimes reduce the rate of growth to its value at 30° C.

(3) **The Method of Balance.**—I shall now describe an extremely delicate method of determining the rate of growth at different temperatures, which is especially suited for the exact determination of the optimum point. A balanced line of record is first obtained by the turning of the balancing wheel of the Crescograph (fig. 168). This regulates the difference of level of the syphon tube, until the spot of light is stationary at the temperature of the room. As the temperature is now raised and the rate of growth increased, the balancing wheel has to be rotated, say to the right, in order to keep the spot of light stationary. The reading of the circular scale at different temperatures thus gives the balanced readings for the corresponding rates of growth at those temperatures. A previous calibration of the value of the circular scale enables us to determine the absolute growth-movements at various temperatures. For the determination of the optimum point, however, this is not necessary. All that has to be done in this case is to keep the spot, which would otherwise drift to the right under a constantly increasing rate of growth, on the point of balance, by the right-handed rotation of the balancing wheel. This must be done as long as the temperature and rate of growth are

ascending towards the optimum. On reaching and passing that point, however, it is found that the spot of light, which has hitherto tended to move to the right, now has its movement suddenly reversed to the left, thus necessitating a corresponding reversal of the balancing rotation. This *turning point* is extremely sharp and well defined, and enables us to make an accurate determination of the optimum temperature within less than a tenth of a degree. From a previous knowledge that the optimum point lies, say, between 35° C. and 36° C., the rise of temperature from 35° C. to 36° C. within the chamber may be adjusted to take place in five minutes, that is to say a rise of one-twentieth of a degree per fifteen seconds. The second observer, watching the delicate thermometer in the plant chamber, calls out at every twentieth of a degree of rise of temperature. The first observer, at the recording drum, notes the temperature of the turning point. It has been said before that the permanent rate of growth for any given temperature is always established in less than fifteen seconds of reaching it. The possible error, owing to this lag, could not therefore exceed one-twentieth of a degree.

TABLE SHOWING CIRCULAR READINGS OF BALANCING WHEEL AT DIFFERENT TEMPERATURES.

<i>Crinum</i> Lily		Hypocotyl of <i>Balsam</i>	
Temperature	Circular reading	Temperature	Circular reading
30° C.	0°	30° C.	0°
31° C.	70°	31° C.	12°
32° C.	171°	32° C.	42°
33° C.	270°	33° C.	86°
34° C.	405°	34° C.	146°
35° C.	538°	34·6° C.	170°
35·4° C.	600°	35° C.	112°
36° C.	494°	36° C.	85°
37° C.	354°	37° C.	37°
38° C.	140°	38° C.	5°

The turning point of another specimen was found to be 35·5° C.

The turning point of another specimen was found to be 34·4° C.

I give above two sets of readings of the balancing wheel, made during two experiments for the determination of the

G G 2

optimum point for *Crinum* Lily and the hypocotyl of *Balsam*. The balanced reading at 30° C. is taken as zero. The adjustment of the stop-cocks for regulation of outflow was different in the two cases.

(4) **The method of excitatory response.**—The method which I am about to describe—and by which the relative rates of growth at different temperatures are afforded indirectly—is one of much theoretical importance, for it proves what I have already suggested, that growth is a phenomenon of excitatory response. This being so, it would follow that the reason why growth is at its optimum at about 35° C. in the case of most tropical plants, is that the excitability of the tissue is greatest at that temperature. The different excitabilities at different temperatures might further be expected, this being true, to offer an independent indication of the characteristic rate of growth of the tissue at those temperatures.

The excitability of the tissue can be tested, in the case of radial organs, by its longitudinal contractile response to external stimulus, which, as we have seen, will be represented in growing organs by a retardation of growth, proportionate to the excitability. We must bear in mind, at this point, certain differences between responsive effects in mature and in growing organs. In the former, owing to the increase of internal energy brought about by rise of temperature, the tissue becomes over-turgid and the internal hydrostatic pressure is greatly increased. The contractile action of external stimulus is thus strongly resisted by the tissue, which in this way antagonises the normal extent of response (p. 338). Similarly, a closed india-rubber ball, fully distended with water, will not yield to any great extent when struck. But if we have, instead, a tube through which water is running, the flexible pipe when struck will yield, and cause a proportionate retardation or reversal of current behind. We have a case somewhat analogous in a growing organ. For here the tissue cannot be regarded as closed, since it is constantly elongating. It therefore represents, not a static

condition of rest, but a dynamic condition of equilibrium, and it will offer little effective resistance to excitatory contraction. We shall therefore expect that in growing organs similar stimuli will induce responsive effects varying in proportion to the changes of excitability in the tissue, under different conditions.

We saw, in the case of *Crinum* Lily, that the optimum temperature was near 35° C., and that at this optimum the rate of growth was something like one and a half to three times as great as at 30° C. At 37° C. we saw, further, that the rate of growth was again reduced, and had become equal to, or lower than, that at 30° C. We might therefore expect that, on recording the retardation of growth in response to external stimulus at three definite temperatures, say 30° C., 35° C., and 37° C., we should find it to be greatest at 35° C. being in fact at that point about one and a half to three times as great as at 30° C. The response at 37° C., on the other hand, which is beyond the optimum, would be much less than at 35° C., being equal to, or even less than, that at 30° C.

TABLE SHOWING VARIATION OF EXCITATORY MECHANICAL RESPONSE AT DIFFERENT TEMPERATURES

Stimulus	Response at temperature of 30° C.	Response at temperature of 35° C.	Response at temperature of 37° C.
Electrical I.	10.5 divisions	37 divisions	10.5 divisions
„ II.	22 „	31 „	13.5 „
Thermal III.	32 „	46 „	24 „
„ IV.	18 „	28 „	12 „

I have made numerous experiments completely bearing out these conclusions. The mode of experimental procedure is as follows: a balanced record is taken at the given temperature, and the growing organ is then subjected to a definite intensity of stimulation, which may consist of tetanic thermal or electrical shocks, lasting for twenty seconds. Records are then made of the resulting contractile retarda-

tion of growth at the different required temperatures. Three responses were taken at each temperature, and were found to be practically the same. Some of these records will be given in the next chapter (fig. 185). I have given the results of four such experiments, carried out on different specimens.

The translocation of the optimum point.—We have thus seen how constant is the optimum point in the same species, under normal conditions; but, since we found that the otherwise constant death-point was liable to be shifted under the disturbance caused by the sudden variation of external conditions (p. 172), so it would appear probable that the optimum point also would be liable to transposition under the influence of similarly disturbing causes. The optimum point of the *Crinum* Lily has been seen to lie, normally speaking, between 35.4° C. and 35.5° C. After a night of heavy rain and gale, however, I found that the optimum point of a specimen of this Lily had fallen to 34.6° C. Under the action of a poison like copper sulphate, again, administered in such dilution as not to kill, but only to retard growth, I have observed the optimum point to be lowered to 34.5° C. In the case of dilute solution of sugar, however, which induces—as we shall see in the next chapter—an increase of growth-activity, I have found the optimum point to be raised to 36.6° C.

Thus under normal conditions the optimum temperature for each species is extremely definite. But circumstances which increase or decrease the rate of growth abnormally, operate also to transpose the optimum point, in the same manner as the death-point was found to be translocated by external influences.

SUMMARY

The difficulties usually encountered in the accurate determination of the effect of temperature on growth have been successfully overcome in the case of four distinct methods.

In taking records of growth at different temperatures, it

is found that the variation from one to another acts as a stimulus, and induces a transient retardation of growth.

But this cause of disturbance is eliminated when the rise of temperature is made gradual and continuous. In this way, by taking a continuous record of growth under uniform rise of temperature, a thermo-crescent curve is obtained, that gives data from which the absolute values of growth at all temperatures may be obtained. From this curve we are also able to obtain an accurate determination of the optimum and maximum points.

The Method of Balance also affords us, by means of a sharply defined turning point, an exact indication of the optimum point.

The optimum point is very definite, and under normal conditions is always constant for a given species; but just as the death-point was found liable to be shifted under abnormal external conditions, so the optimum point also is apt to be transposed under similarly disturbing causes.

That growth is a phenomenon of excitatory response is demonstrated by the fact that the growth-rate is increased or decreased at different temperatures, in proportion to the excitability of the tissue at the same points, as indicated by its contractile response.

CHAPTER XXXIV

ON AN ATTEMPT TO DETECT AND MEASURE LATENT STIMULUS, AND ON THE STUDY OF PERIODIC AFTER- EFFECTS

Positive and negative after-effects—Extreme delicacy of the Method of Balance—
Detection of absorbed stimulus by negative after-effect—Constancy of sum of
direct and indirect after-effects—Latent component almost vanishing above the
optimum—Variation of receptivity—Direct and indirect response of plant in
sub-tonic condition—Table showing direct and indirect effects at different
temperatures—Is the change induced by stimulus always of an explosive
chemical character?—Relation between stimulus and response in different
tonic conditions—After-effect—Factors which determine periodic after-effects :
(1) Stimulus of light—(2) Temperature—(3) Chemical stimulus—(4) Tur-
gidity—Continuous photographic record of the pulsations of *Desmodium*—
Record of periodic variation of rate of growth—Continuous photographic
record of periodic variations of transpiration—Continuous photographic record
of the variation of the rate of growth—Annual rings and seasonal periodicity.

By regarding the plant as a machine, as we did in the course of
the earlier chapters, we were enabled to understand the possi-
bility of its absorbing, and holding latent, more or less of the
incident stimulus (p. 124). The experimental demonstration
of this would, however, be difficult, in the case of the ordinary
response of motile organs ; for though we have seen that ex-
ternal stimulus and the absorbed internal energy are opposite
in their responsive effects, yet in the ordinary records of
mechanical response it is not easy to discriminate that part
of the effect which is due to the latter element ; for while
it is true that the presence of internal energy would tend to
hasten the recovery, it is still impossible to distinguish with
certainty a recovery so hastened from one which is natural.
The fact that excess of stimulus is transformed into latent
energy is demonstrated, however, by the occurrence of
multiple response.

Positive and negative after-effects.—We have seen that when a moderately strong stimulus acts on a responding organ, a short time elapses before the initiation of the response, and this is known as the latent period ; but when response has been initiated, it persists for some time, even on the cessation of the stimulus, and this is known as the after-effect. I shall, however, for important reasons, which will appear later, further distinguish it as the *positive after-effect*. By the term positive after-effect, then, is meant the continuation of a response evoked by external stimulus, on the cessation of that stimulus. We may, for example, imagine a heavy elastic spring immersed in a viscous fluid. If this be subjected to a sudden compressional blow, then, after a short latent period, it will begin to undergo compression, and this compressional movement will continue for some time, even on the cessation of the blow that caused it, thus exhibiting a positive after-effect. But a spring compressed in this manner contains some amount of latent or potential energy, on account of which it next begins to expand, exhibiting a movement opposite to the first. This second movement, due to the latent energy, we may distinguish as the *negative after-effect*. This negative after-effect, it should further be stated, may sometimes be separated from the direct effect by a considerable interval of time. This may be seen in a viscous wire subjected to a torsional impulse. After the twisting has ceased, some time elapses before the wire is seen to begin the contrary, or negative, movement of untwisting, which is accomplished very slowly, and may even take hours to complete.

Now, it occurred to me that, in the response of growth, it was possible to find a means of detecting whether the external stimulus in the case of living tissue might, or might not, become partially latent, to be similarly manifested later, in the form of the negative after-effect ; for if we take a balanced horizontal record of growth, then the direct effect of external stimulus will be seen in that retardation which is shown in the shifting of the line—here, for convenience of

inspection, represented upwards (fig. 185). On the cessation of external stimulus, if the recovery of the excited region be merely passive, it is evident that this ascending line will gradually return to the horizontal, as in the third record of fig. 185; that is to say, the retarded will be exchanged by degrees for the normal rate of growth. But if some portion of the external stimulus be held latent in the tissue, this will go to increase the internal energy of the plant. Now, we have already seen that the effect of augmented internal energy is exhibited in an increase of the rate of growth above the normal, shown in a balanced response-curve by an opposite movement to that of retardation, constituting the negative after-effect. Such a negative after-effect, consisting of an enhanced rate of growth, will persist until the energy thus held latent is exhausted, when the curve will again return to the horizontal. Thus, the up curve will represent the direct effect of external stimulus, and the down curve the acceleration of growth due to absorbed stimulus, or the negative after-effect.

Extreme delicacy of the Method of Balance.—Such transient variations in the rate of growth, occurring as the expression of the absorbed fraction of incident stimulus, would have been incapable of detection by the ordinary auxonometric method of growth-record; for here, owing to the relatively slight magnification which is possible, it takes nearly half an hour to obtain data from which the normal rate of growth may be inferred. Another half-hour's observation would be necessary before we could infer the occurrence of variation under changed conditions, and it is clear that, during a period relatively so long, the plant may undergo spontaneous changes. The after-effects, however, which we now wish to detect, are found to take place immediately, and to last for a few minutes only, in the case of moderate stimulation. Even with our crescographic arrangement, though the usual magnification is a thousand times, the variation constituting the after-effect is seen only in a slight change of the slope of the curve; but when the Method of

Balance is employed, the ordinary magnification is enough to show, in a very marked manner, all the phases of these transient variations. The records here reproduced have been in fact reduced to one-third of the originals.

The sensitiveness of the arrangement can be very much exalted by observing the balanced line of light with its deviations, through a telescope placed at a distance. In this way, I have been able to detect a variation from the normal rate of growth, of so little as a two millionth part of 1 mm. per second, within so short a period of observation as ten seconds.

Detection of absorbed stimulus by negative after-effect.—We must now revert to the question of the detection of latent stimulus by an increase in the rate of growth, and we shall first take that simple case in which there is no loss of energy from irreversible effects due to molecular friction. The energy of external stimulus will here find complete expression in doing external and internal work. If the external stimulus remain constant, the sum of these two—that is to say, the direct or immediate, and the indirect effects—will also remain constant ; but if, under the same circumstances, one of these factors, say the direct effect, should for any reason be enhanced, we might then expect that its complement, the indirect effect, would undergo a corresponding diminution ; while, if the direct effect should be small, the indirect effect would show augmentation.

These theoretical considerations are found very strikingly verified in the experiment which I shall now describe. I first took a balanced record of growth in a specimen of *Crinum* Lily, at 30° C. This was then subjected to thermal shocks for five seconds. The direct response, as will be seen from the first record in fig. 185, which is reduced to one-third of the original, was a retardation of growth represented by 33 divisions. On the cessation of stimulus, however, the rate of growth did not at once return to the normal, but exhibited the effect of absorbed energy by an acceleration shown in the down curve, and represented by 13 divisions, after which it became normal. The same stimulus was now repeated, and

the direct effect was a retardation of 31, which was followed by an augmentation of 14 divisions. Thus the sum of these two effects is practically constant, being in one case 46, and in the other 45, divisions.

Constancy of sum of direct effect and indirect after-effect.—This constancy, however, becomes still more remarkable when the same plant is raised to a temperature of 35° C. and subjected once more to the same stimulation. The direct effect is now shown by a retardation which may be represented as 39, and the indirect by 9, divisions.

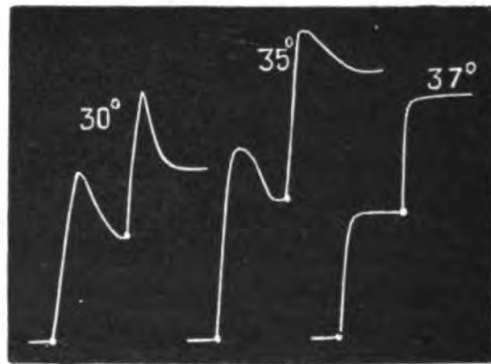

FIG. 185. Series of Responses of Growing Organ of *Crinum* Lily, taken under Balanced Conditions at Three Different Temperatures

On comparing these records it will be seen that the direct effect increases up to the optimum, and that the indirect effect of accelerated growth decreases. Beyond the optimum, at 37° C., there is no latent component, as shown by recovery from direct effect to normal rate of growth.

constant when stimulus is the same, but also that this sum itself remains approximately constant at different temperatures within the optimum ; and, further, we see that as the excitability is increased in approaching the optimum, the direct effect also increases at the expense of the indirect. In other words, when the tissue is at its optimum tonic condition, its capacity for the absorption of stimulus being already fully satisfied, the external stimulus tends to be immediately expended, in direct response, allowing relatively little to become latent.

In the second response of this second series, we have a direct effect of 37, and an indirect effect of 8, divisions. Thus the sum of the first direct and indirect effects is 48, and the sum of the second 45, divisions, the mean of the two at 35° C. being 46.5 divisions, while the mean at 30° C. was 45.5 divisions. We have found, then, not only that the sum of direct and indirect effects at a given temperature is practically

Latent component almost vanishing above the optimum.—As an extreme instance of this, we may take the response at a temperature beyond the optimum, say at 37° C. Here, by its environmental conditions, the plant is already supplied with an excess of energy. And besides this, there is the fact which we have already noticed, that its general excitability is diminished, so as to be equal to, or less than, that at 30° C. At these two temperatures, then—of 30° C. and 37° C.—we have two conditions of excitability more or less the same, but with a different history.

Below the optimum there is an unsatisfied capacity for absorption of stimulus, whereas above it this capacity has been fully met. It would therefore appear that the power of the tissue to hold stimulus latent is diminished progressively up to the optimum, till beyond that point it practically disappears. I obtained a remarkable confirmation of this inference in the course of my experiments. In the experiment just described, for example, the direct response was a retardation of twenty-four divisions, and there was no indirect effect, showing that little or no stimulus had become latent (fig. 185).

Variation of receptivity.—In the experiments described, the sum of the direct and the indirect effects, up to the optimum, had been found to be approximately constant, that is to say, a total response of about forty-six divisions. At 37° C., however, we see the total response reduced to twenty-four divisions without any latent component. And since the total response measures for us the amount of stimulus taken up by the tissue, it would appear that at 37° C. not only is the power to hold stimulus latent lost, but also that the general *receptivity* of the tissue is very much reduced. It is thus seen that the condition of a tissue modifies its receptive power; hence it is possible for different parts of the same organ—say, for instance, the tip and the growing region—being in different conditions, to possess different receptivities.

Direct and indirect response of plant in sub-tonic condition.—Turning from this case of excess of energy to

that in which it is below par, the plant being in a sub-tonic condition of arrested growth, we find that external stimulus gives rise to little expression in direct response. External stimulus is found under such circumstances mainly to increase the store of internal energy, in consequence of which we obtain the indirect response of renewed growth. In such a condition, the plant has a great capacity for the absorption of external energy. After growth has commenced, the energy of incident stimulus finds bifurcated expression, by inducing direct or immediate response, and by the indirect or negative after-effect, of enhanced rate of growth (p. 434). The sum total of these two—external stimulus being the same—remains approximately constant, till the optimum tonic condition is reached. The direct and indirect effects are thus, up to this point, complementary to each other. After passing this point, however, when the plant is possessed of excess of energy, its power of absorbing stimulus appears to undergo diminution. The direct effect of stimulus is then found reduced, and there is no negative after-effect, due to the absorbed component of the external stimulus.

From these considerations we are enabled to understand the curious growth-response that was observed in varying the temperature of the plant from 34° C. to 35° C. (fig. 182, p. 445).

The change of temperature was in that case accomplished, as will be remembered, by changing the intensity of the electrical heating current. The change from 34° C. to 35° C. thus produced was not, however, brought about at once, but took place in the course of a period of three minutes. We had consequently the stimulating effect of *variation* of temperature bringing about contraction, followed by the accelerated rate of growth which constituted the negative after-effect of that stimulus, *plus* the accelerated rate of growth due to rising temperature. That the first of these two factors played a considerable part in this acceleration, is seen from the fact that the permanent increase in the rate of growth characteristic of the higher temperature of 35° C. is smaller than the

acceleration that precedes it. Incidentally, we see here the difference between the temperature-effect *per se*, and the stimulating effect of sudden variations of temperature, constituting thermal shocks.

In the simple case we have just studied, where the whole amount of incident stimulus was expressed in work external and internal, without any loss from molecular friction, the sum total of the two forms of response was found approximately the same under a constant stimulus; but in other cases, where a certain amount of energy is wasted in overcoming molecular sluggishness, the results will be slightly different, for at a temperature below the optimum a portion of the stimulus will be wasted in overcoming such sluggishness, whereas near the optimum temperature the loss entailed on this account will be very slight. Hence, the sum of direct and indirect responses, near the optimum, will in such cases be somewhat greater than at a temperature several degrees lower. I give below a table which shows at a glance the direct effect and the indirect after-effect, obtained at the three temperatures of 30° C., 35° C., and 37° C. respectively, with three different specimens, one of which was a rice-seedling (*Oryza sativa*), and the two others flower-buds of *Crinum* Lily. Each response given is the mean of three.

TABLE SHOWING DIRECT AND INDIRECT EFFECTS AT THREE DIFFERENT TEMPERATURES

Specimen	Temperature	Direct effect (retardation of growth)	Indirect effect (acceleration of growth)	Total effect
1. Seedling of <i>Oryza sativa</i>	30° C.	15 divisions	10 divisions	25 divisions
	35° C.	20 "	6·5 "	26·5 "
	37° C.	10 "	0 "	10 "
2. <i>Crinum</i> Lily	30° C.	32 divisions	13·5 divisions	45·5 divisions
	35° C.	38 "	8·5 "	46·5 "
	37° C.	24 "	0 "	24 "
3. <i>Crinum</i> Lily	30° C.	18 divisions	17 divisions	35 divisions
	35° C.	28 "	13 "	41 "
	37° C.	12 "	0 "	12 "

It will be seen from the readings given by specimens 1 and 2, that up to the optimum the total response is approximately constant, while at 37° C. there is no expression of energy held latent. The condition of specimen 3 having been at starting somewhat sub-tonic, the total effect is heightened at the optimum, for reasons which have been explained. It has already been said that the proportion of stimulus held latent will be greater with the degree of sub-tonicity of the plant. That this was the condition of specimen 3, then, is demonstrated, not only by the increase of the total effect at the optimum temperature, but also by the fact that at 30° C. so large a proportion of the stimulus as almost exactly one-half is held latent. At 37° C. here, as in the other cases, there was no latent component.

Is the change induced by stimulus always of an explosive character?—It has generally been supposed that stimulus causes response by an explosive chemical change. According to this theory, the stimulus acts as upon a trigger, to release suddenly a large amount of energy previously held latent in the tissue. The response is thus assumed to be always disproportionately larger than the stimulus, and to be brought about by chemical degradation, or dissimilation of the living tissue. The tissue, thus reduced below par, is supposed to be restored by the process of assimilation.

In Chapter X., however—on Theories concerning Different Types of Response—I adduced considerations, showing that there are cases of responsive phenomena in which this description would not hold good; that is to say, there are instances in which the response cannot be due to a chemical down change of explosive character. Nor is it always true that response is disproportionally larger than stimulus. The series of experiments which has just been described offers conclusive evidence on this point, of a quantitative character. Further, if the theory of an explosive down change had been the real explanation of response in general, then it is clear that in the case of the response induced by stimulus in growing organs, recovery would have taken place slowly, and

would have culminated in the restoration of the original rate of growth ; but we actually find, on the contrary, that, immediately following the responsive retardation, there is an acceleration of growth above the normal, and the true recovery, or restoration of the normal rate, takes place only after this. Thus there is here, instead of a run down, an actual increase, of the energy of the system.

Again, from this constancy of the sum of the immediate and the after-effects of stimulus, we can see that, as in an inorganic system, so also in a living organism, the law of the Conservation of Energy holds good. For while at the optimum point the entire stimulus finds expression in direct response (stimulus being here equal to response), below the optimum the direct response is less than the stimulus, the missing fraction being left to find expression in the negative after-effect.

Relation between stimulus and response in different tonic conditions.—The experiments which I have described were carried out under the thermal form of stimulation, which is, as already explained, the most satisfactory in practice. We shall hereafter come across instances of the after-effect of accelerated growth, as caused by stimulus of light. And a similar after-effect has already been seen to be caused by electrical stimulus (p. 436). But for the clear demonstration of this particular effect, electrical stimulus is not very suitable, inasmuch as it is apt to induce fatigue and, through electrical polarisation, a certain amount of tissue-change. I shall, however, describe an experiment, using this mode of stimulation, which, by its responsive indications, will demonstrate certain differences in the internal conditions of tissues, according as they are sub- or super-tonic.

I have shown that the general excitability of the tissue at 30° C. is superficially the same as that at 37° C. or thereabouts ; that is to say, the direct responses at these two temperatures are in some cases approximately the same ; but we have seen that there is a difference of molecular condition at these two points, for at 30° C. the tissue is capable of holding a portion

H H

of the incident stimulus latent, by which its molecular mobility becomes enhanced, whereas at 37° C. there is already the fullest molecular mobility. If now we apply at 30° C. stimuli which increase, say, in arithmetical progression, we see that by the very reception of the increasing stimuli the tissue is made to approach more and more closely to the optimum condition, at which point, as we have seen, the whole of the stimulus is given up immediately, in the form of direct response. Hence the curve showing the relation between stimulus and response in a tissue that is in a condition below the optimum will be steep, and somewhat convex to the abscissa which represents the stimulus ; but at 37° C., when no molecular sluggishness has to be overcome, we may expect the response to increase proportionately with the stimulus ; that is to say, the curve showing the relation between stimulus and response will now tend to be a straight line.

In order to apply electrical stimulation whose intensity was increased by known amounts, I used an induction coil, the primary coil of which was completely within the secondary. The ordinary method of Du Bois-Reymond's sliding coil was not very suitable in this case, because the increasing intensity obtained by sliding the coil inwards is merely qualitative. The required definite increase of induction-shock I secured by suitable augmentations in the value of the current that flowed round the primary coil. In order to determine these values, a preliminary experiment was carried out. A storage battery was in circuit with the primary coil, which had interposed in it also an ammeter and a rheostat. By increasing the resistance, a moderate current, say C , read by the ammeter, was adjusted to flow round the circuit. The secondary circuit contained a ballistic galvanometer, which by its throw indicated the intensity of the induced current at make or break of the primary circuit. When the first current, C , had given an induced current, which caused a deflection of, say, 30, it was increased to C_1 , when the deflection due to induction was found to be 50 ; and lastly a third value, or C_2 , was found, whose induction-effect was 70. In this manner,

induction-shocks, increasing in arithmetical progression as 3 to 5 to 7, were determined. Tetanic shocks of the described intensity—3, 5, 7—the total application of each group being a period of 5", were now given, response being taken after each. In this manner two series of responses were obtained at the temperatures of 30° C. and 37° C. At both temperatures with the stimulus-intensity of 3, the responses given by this particular specimen were the same. But while at 37° C. the lower of the two curves, showing the relation between stimulus and response, is a straight line, that at 30° C., the upper of the two, is seen to ascend more steeply and to exhibit convexity to the abscissa (fig. 186).

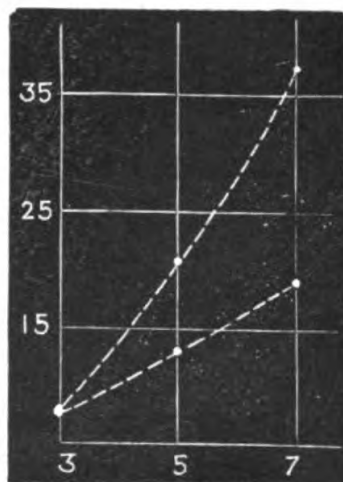

FIG. 186. Curve showing the Relation between Stimulus and Response in the same Organ, under the two different Tonic Conditions of 30° C. (upper curve) and 37° C. (lower curve)

After-effect.—The phenomenon which is generally referred to as the after-effect is characterised by so many complexities as to have been regarded as highly perplexing. After the foregoing analysis, however, by which it has been resolved into two elements, much of this obscurity will be found to have disappeared. We saw that the first effect induced by a very strong or long-continued external stimulus consisted in bringing about the continuation of the direct effect itself, its persistence depending on the intensity and duration of that stimulation. And this we have distinguished as the positive after-effect. A component part of the external stimulus, however, as we also saw, becomes latent, thus increasing the internal energy; and the expression due to this element—the negative after-effect—is opposite in sign to the effect of direct stimulus and its positive

The abscissa represents the intensity of stimulus, and the ordinate the extent of response. The response was the same in both cases when the stimulus-intensity was 3; but later, the curve for 30° C. is seen to rise more steeply than that at 37° C., exhibiting at the same time convexity to the abscissa.

H H 2

after-effect. Thus a plant under natural conditions, acted upon by different stimuli, gives to each stimulus direct response, direct after-response, and indirect response. But as all these individual stimuli do not act, or cease to act, simultaneously, we can easily understand the infinite complexity of the combinations which take place between the direct and indirect effects of stimuli of unlike forms, whose maxima, instead of being coincident, are superposed on each other, with various differences of phase.

Factors which determine periodic after-effects.—We shall now proceed to enumerate some of the most important stimulating factors instrumental in modifying the response of growth.

(1) *Stimulus of light.*—If we take the average rate of growth during the twenty-four hours as the normal, then the direct effect of this stimulus will appear as a retardation of that normal rate of growth, and, after the long-continued action of the whole day's illumination, this retardation may persist for a time as the positive after-effect. Later, however, on account of the stimulus which has been absorbed and held latent, we shall observe an acceleration of growth above the normal, or a negative after-effect. The persistence, again, of this negative after-effect will depend on the amount of the energy held latent by the tissue. The diurnal sequence of light and darkness will, after long repetition, impress itself upon the organism, and, other factors remaining constant, will find expression as periodic retardation and acceleration of growth during day and night ; such periodicity continuing to show itself, for some time, even when the plant is kept in continuous darkness.

(2) *Temperature.*—The effect of temperature up to the optimum point will, by increasing the internal energy, prove favourable to growth. Thus, the temperature during daylight will usually be favourable, with the exception of the tropical noon, when it may be excessive. A certain amount of heat, again, may be stored up in the plant to give the after-effect. At night, if the fall of temperature be very great, there will be, relatively to this factor, a retardation of growth.

(3) *Chemical stimulus*.—This we see supplied by the salts taken up by the roots, and by the process of photo-synthesis in the leaves. The amount of the former supply is dependent not only on the richness of the soil, but also on the suctional activity of the plant; and the latter on the effective intensity of light.

(4) *Turgidity*.—The turgid condition of the plant will depend, firstly, on the supply of water; secondly, on the suctional activity; and thirdly, on the relative absence of a loss of water by transpiration. We have seen how watering the roots of the plant will cause an immediate response of enhanced growth, and the seasonal periodicity induced by this cause may be observed in a very striking manner in tropical countries.

The suctional activity, depending as it does on the internal energy of the plant, will tend to be augmented by an advantageous temperature, and by the after-effect of the absorbed stimulus of light; but the turgid condition will be reduced by active transpiration, which is relatively greater in the daytime.

We thus see how numerous are the factors which co-operate to bring about periodic fluctuations in the rate of growth during every twenty-four hours. Of all these factors, the alternation of day and night is the most pronounced in its action. The curve of growth, then, will exhibit not only a large wave of alternation due to the diurnal period, but also a number of sub-waves. And even beyond these, superposed upon them, we may expect, when the magnification is sufficiently great, to observe systems of still smaller wavelets, caused by the rhythmicity of growth.

Continuous photographic record of the pulsations of *Desmodium*.—Before describing the periodic diurnal variation of that autonomous response which we know as growth, it occurred to me that a continuous record of another form of autonomous response—that is to say, of the rhythmic pulsations of *Desmodium*—might prove interesting. I was fortunate enough to succeed in obtaining a very good record

of these pulsations during a period of twelve hours, by means of photography. The record began at 6 P.M. and ended at 6 A.M. During this time there were no fewer than 180 constituent pulses, and it will be noticed that these again fall into groupings, whose average period is a little over an hour, there being about ten such groups in the course of twelve hours (fig. 187).

Returning now to the question of periodic growth-fluctuations, Sachs and others have measured the different rates of growth at various hours within the twenty-four, and from the data thus obtained have constructed curves which showed

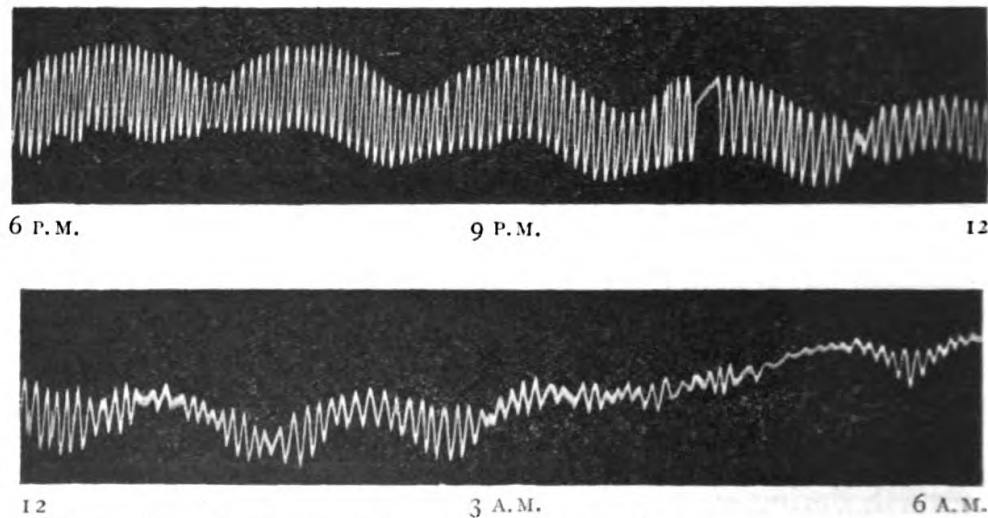

FIG. 187. Continuous Photographic Record of Autonomous Pulsation of *Desmodium gyrans* from 6 P.M. to 6 A.M.

The lower record is in continuation of the upper.

the periodicity of the rate of growth. These curves exhibit the daily period in a marked manner; but the subordinate waves are more or less obliterated, in consequence of the fact that the data from which the curves were constructed were obtained from discontinuous observations. The curves thus deduced show marked differences also, according as their points were determined frequently or at long intervals.

Record of periodic variation of rate of growth.—For this reason it appeared to me important to devise means by which, not the growth, but the *variations*, of its rate might be automatically recorded, directly and continuously, for any

length of time. The curve thus obtained ought instantaneously to mark the fluctuations of rate throughout the period in question. This I have been able to accomplish by means of a modified Method of Balance. From the description of that method already given, it will be understood that after the establishment of the average balance, if the rate increases, the curve will move upwards. When, after this, the rate of growth returns to the normal, the balance will be re-established, and the curve become again horizontal; but if the growth at any time should fall below the average, the curve will descend. In this way periodic fluctuations in the rate of growth may be recorded.

For the purposes of the modified method of record, the compensating arrangement used for balance has to be somewhat altered. In recording these long periodic changes, we have fluctuations of larger amplitude than those of autonomous pulsation. The spot of light which is thrown from the mirror of the experimental Optic Lever upon the second, or compensating, mirror is thus apt to fall outside the range of the latter. In order to overcome this difficulty I mount the plant on the float itself, and adjust the outflow of water from the cylinder, so that the upward growth of the plant is, at a given moment, exactly compensated by the descent of the float supporting it. Deviations above or below the balanced rate of growth may then be followed with a recording pen,

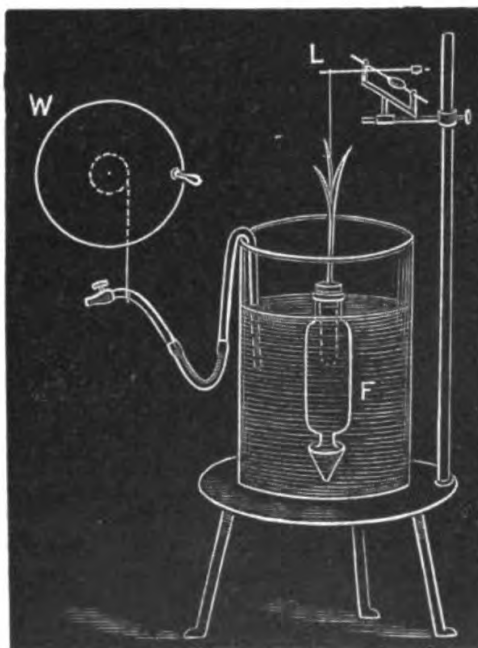

FIG. 188. Hydrometric Apparatus for Recording Continuous Variation of Rate of Growth

F, float, supporting the plant, which is attached by thread to optic lever, L. W, wheel, for adjustment of balancing overflow.

or will record themselves on a sensitised photographic film wrapped round the revolving drum.

In carrying out such a continuous record, certain precautions are necessary. Owing to transpiration, the float on which the plant is mounted will become lighter, causing an ascensional movement of the record. In order to obviate this, it is only necessary (1) to weight the float to such an extent that the variation caused by transpiration is negligible; and (2), in addition to this, the diameter of the cylindrical float may be so increased as to reduce still further the ascensional movement due to loss of weight by transpiration. By these means the error from this source may be reduced

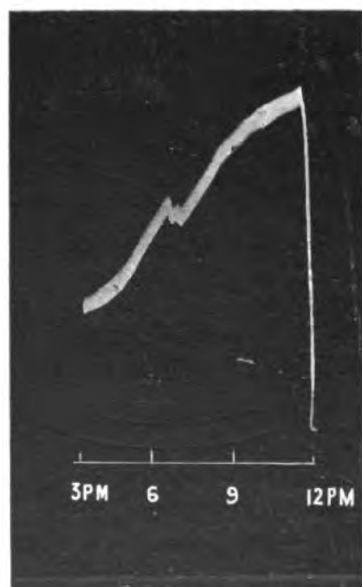

FIG. 189. Photographic Record showing Variation of Rate of Transpiration in *Cucurbita*, from 3 P.M. to 12 P.M.

The rate is seen to undergo enhancement till about 11.30 P.M., after which there is a rapid fall of the rate of transpiration.

to any extent desired. In the figure of the apparatus which is here given (fig. 188), the specimen was a young seedling of *Oryza sativa*, in which transpiration was relatively little. I shall presently give photographic records obtained in the manner described.

Continuous photographic record of periodic variations of transpiration. — By a somewhat similar method we are enabled to determine the periodic variation of the rate of transpiration. In this case, the plant is mounted with its roots in a test-tube, which acts like a float, and is partially filled with water, but not so full as to make it sink. The test-tube containing the plant is attached to one arm of the Optic Lever, and the outflow from the outer cylinder so adjusted that

the ascensional movement of the test-tube, due to its loss of weight by transpiration, is exactly balanced by the subsidence of the water-level of the water that buoys it up. In order

to prevent the loss of water from the cylinder by evaporation, a film of oil covers the surface. In this way I obtained the accompanying record of variation of rate of transpiration in a young specimen of *Cucurbita*, from 3 P.M. to 12 P.M. (fig. 189). It will be noticed that in this case there is an enhancement of transpiration which continues with a single fluctuation till past 11 P.M., after which there is a sudden depression of the rate.

Continuous photographic record of the diurnal variation of the rate of growth.—I shall first give a photographic record (fig. 190) taken from a seedling of *Oryza sativa*, only

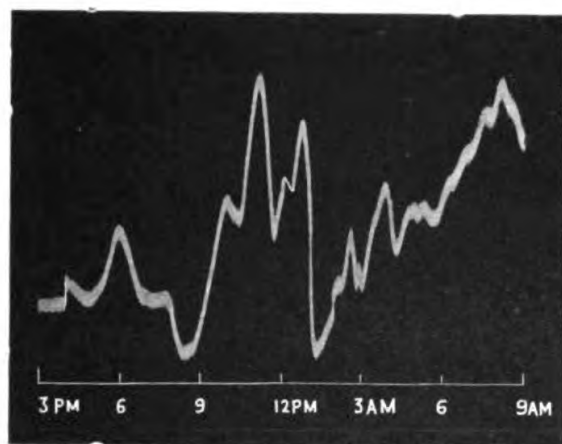

FIG. 190. Continuous Photographic Record of Variation of Rate of Growth in Four Days' Old Seedling of *Oryza sativa*, from 3 P.M. till 9 A.M., that is during Eighteen Hours

four days old. The diurnal periodicity has already, it will be seen, become fairly impressed, though it is not yet sufficiently powerful to mask, to any great extent, the subsidiary periodicities induced by other factors. The record, it must be remembered, was taken in continuous darkness, being commenced at 3 P.M., when it was balanced. From this time to 9 P.M. there were three pulsations. From 6 till after 8 P.M. there was depression of the average rate of growth, after which it rose somewhat rapidly till 12.30 A.M., exhibiting during that period two groups of two pulsations each. There was now a quick fall for the next half-hour, and after this

the growth-rate rose more or less continuously till 8 A.M. The growth-rate then began to fall during the course of the day.

The second record was taken with a seedling of *Tamarindus indica* fourteen days old, the diurnal periodicity being thus deeply impressed. It was placed in the dark room, mounted on the float, and the balanced record begun at 3 P.M. It will be seen that, as the positive after-effect of the day's illumination, there was a depression of the rate

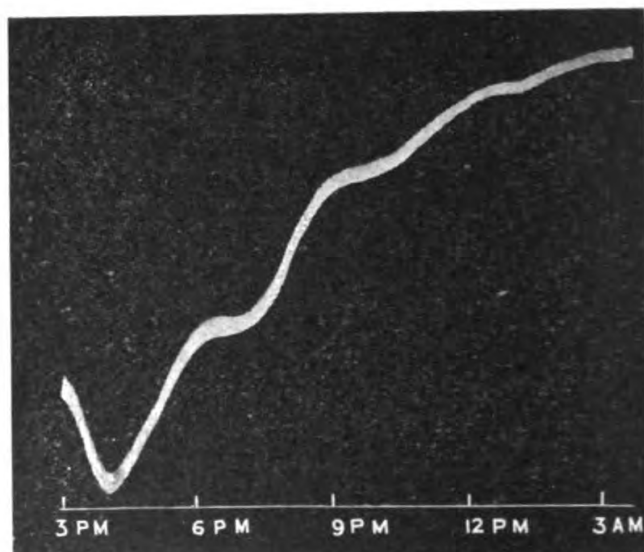

FIG. 191. Continuous Photographic Record of Variation of Rate of Growth in Seedling of *Tamarindus indica*, a Fortnight Old, from 3 P.M. to 3 A.M.

Owing to positive after-effect of daylight, there is a depression of rate of growth, although the seedling was now placed in a dark room. In the evening, however, the rate began to rise.

of growth, though the plant was kept in the dark. This persisted for two hours, till 5 P.M., after which the rate showed increase, there being three pulsations before the end of the record, at 3 A.M. (fig. 191).

Annual rings of wood and seasonal periodicity.—The different growths of wood in spring and autumn, leading to the formations known as 'annual rings,' constitute a phenomenon of growth not yet fully explained. I may here point out an important factor in connection with this subject. It

has already been demonstrated that growth is a phenomenon of excitatory reaction, being at its maximum when the excitability of the tissue is greatest. Thus varying expressions of growth at the two seasons, as seen in the production of different sized cells during spring and autumn, would appear natural, if they could be correlated to differences of excitability, characteristic of those seasons. Now all modes of testing degrees of excitability lead to the conclusion that while it is very great in spring and summer, it is very much enfeebled in autumn and winter. Thus, in the latter season, contractility under stimulation, velocity of transmission of excitation, and the electrical response of a tissue, are all found to undergo a marked diminution, as compared with spring and summer.

SUMMARY

On the cessation of strong stimulus the responsive movement continues for a time in the same direction. This is the *positive* after-effect.

A portion of the incident stimulus is absorbed and held latent, thus increasing the latent energy of the plant. On the cessation of stimulus this latent component, either immediately or after a time, finds expression in an opposite responsive movement. This is the *negative* after-effect.

In the case of growth-response, the positive after-effect consists in the persistence for a time of the retardation of growth, and the negative after-effect exhibits itself as an acceleration of the rate of growth above the normal.

With moderate stimulus and under normal conditions the sum of the direct effect and the negative after-effect (due to the latent component) remains constant up to the optimum; that is to say, the sum of the external work (direct effect) and internal work (negative after-effect) done by the stimulus is the same. The direct and the negative after-effect of stimulus are thus complementary.

At the exact optimum almost the whole stimulus will find expression in direct response, there being little or no

latent component. In a sub-tonic condition, on the other hand, a greater proportion of the stimulus is temporarily held latent, and expresses itself as the negative after-effect, the direct responses being here correspondingly diminished.

Above the optimum there is no latent component, and the general receptivity of the organ shows great diminution.

From the constancy of the sum of the direct and indirect effects it is demonstrated that, with regard to some forms of response at least, response is not disproportionately greater than stimulus. Thus the theory that response must always be due to an explosive chemical change does not hold good.

The curve showing the relation between stimulus and response is appropriately modified by the tonic condition of the tissue.

As each stimulus of every form thus finds expression in direct response, direct after-effect, and indirect after-effect, and as there are many forms of stimulus which under natural conditions act on the plant, whose maxima, instead of being coincident, are superposed on each other, in varying differences of phase, highly complex periodicities are induced, and find expression in the various forms of plant response.

Among such varying factors of stimulation may be mentioned the diurnal alternation of light, temperature, chemical stimulus, and varying turgescence.

The induced periodicities which result from the conditions described may be seen in the periodic groupings which appear in a continuous record of the autonomous pulsations of *Desmodium* for example.

The autonomous response of growth, as the result of the periodically acting stimuli mentioned, exhibits not only a large wave of alternation, due to the diurnal period, but also a number of sub-waves. But the impression made on the organism by the diurnal period is the deepest of these, and tends in an old plant to subordinate all others in a marked degree. In the responses of a seedling a few days old, however, the minor waves are very distinct.

CHAPTER XXXV

AN INVESTIGATION INTO THE DIFFERENT EFFECTS OF DRUGS ON PLANTS OF DIFFERENT 'CONSTITUTIONS'

General consideration of the problem—'Constitution' and the elements which determine it—Methods of investigation—Action of carbonic acid gas—Action of ether—Effect of solution of sodium carbonate—Effect of solution of sugar—Effect of alcohol—Effect of acids—Effect of alkali—Antagonistic action of alkalis and acids—Action of strong solution of sodium chloride—Effect of poisonous solution of copper sulphate—Opposite effects of the same dose on different constitutions—Opposite effects of large and small doses.

WE have already studied the effect of various chemical agents on the physiological condition of plants, as seen from the modifications induced by them in ordinary and in autonomous responses. We have also noticed the remarkable similarity between these effects in the two cases of plant and animal tissues, and I have drawn attention to the great practical utility of these investigations, inasmuch as the experiments carried out on plants may be made to throw light on many obscure phenomena regarding the effects of drugs on the animal system. One puzzling fact, however, which is encountered in medical practice, is, that the same drug will often produce varying effects on different individuals; and this is vaguely ascribed to dissimilarity of 'constitution.'

Similarly, we have sometimes seen different effects to occur in plants under the action of a single given drug. A large dose of some depressing agent, for example, though it will ultimately produce the depressing effect, will not always do so at once, for in some cases there will be a preliminary period of exaltation of response. The same toxic dose, again, which will in some instances kill the plant, will

in others fail to do so, the plant being ultimately able to shake off the depressing influence after an interval of struggle. In studying suctional response, again, we found that copper sulphate applied at the roots induced, in some cases, an immediate arrest of suction, while in other instances this arrest did not take place till after a long time. The depression of suction which was induced by the application of strong sodium chloride, again, was in some cases immediate, and in others preceded by a fairly long period of an exalted rate of suction (pp. 384, 385). All these variations of results we regarded as due to individual differences of constitution, or of tonic condition.

Thus we can only hope to arrive at a complete knowledge regarding the action of any given drug if we first obtain a precise understanding of what is meant by constitution, and of how, for experimental purposes, specimens of a definite characteristic constitution can be secured, while others can be subjected to an ascertained variation in a pre-determined manner. It will thus be made possible to study the effect of a drug, by applying it (1) in solutions of different strengths to a number of plants of identical constitution; and (2) in a single strength of solution to specimens of definitely varying constitutions.

'Constitution' and the elements which determine it.—
The first factor in determining constitution will consist of those properties which have been impressed upon the plant by its heredity. The second will depend upon its environment. The sum total of the energy absorbed by the plant from its surroundings we have already designated as the tonic condition. It is clear that we may secure the factor of a constant heredity by taking either seedlings from the same batch of seeds, or organs from the same plant. These, again, when maintained under the same environmental conditions, in respect of temperature and other circumstances, will give us plants having practically the same constitution. In order, next, to obtain specimens of different but well-ascertained constitutions, it is only necessary to keep these under known

differences of tonic condition. Thus, all other factors being maintained constant, we may have three clearly defined states, in the case, say, of *Crinum* Lily, according as it is kept at a temperature of 30° C., 34° C., or 37° C. The first of these we may regard as the normal; the second as near the optimum; and the third as intermediate between optimum and maximum. The excitability of the plant kept at the optimum will be the greatest; but though the excitabilities of those at 30° C. and 37° C. will be approximately the same, yet, in the latter case, the plant will possess an excess of latent energy which will be wanting in the former. Having thus secured these definite artificial constitutions of different values, some of the investigations given at the end of this chapter will show how free from uncertainty the action of drugs may be made, and how rational an explanation can be given of the observed variations of effect.

Methods of investigation.—I shall now proceed to describe the general methods of experiment, in studying the effects of drugs, from the modifications which they induce in growth-response. There are two ways of doing this. According to the first, we take a record of the growth before and after the application of the reagent. From the variation then seen in the rate of growth the excitatory or depressing nature of the drug may be ascertained. The second, or **Method of the Balanced Crescograph**, is much more delicate; it exhibits each transient variation of response, and its time-relations, with perfect clearness. The balanced horizontal record, which is first taken, indicates the normal rate of growth. A deviation upwards from this horizontal line will indicate accelerated growth; a return to the horizontal will mean a regaining of the normal rate; and a deviation downwards will show responsive retardation. The specimens used for this investigation were *Crinum* Lilies, and, unless stated to the contrary, the experiments were carried out at the normal temperature of 30° C.

Action of carbonic acid gas.—I first give a record of the effect of carbonic acid gas on growth (fig. 192), taken by

the Unbalanced Method. The normal rate of growth was .006 mm. per minute. On passing CO_2 into the plant chamber the immediate effect was an acceleration, the rate for the next five minutes being .009 mm. or $1\frac{1}{2}$ times the normal. Under the continued action of carbonic acid, however, the rate underwent a rapid diminution, and, as is seen

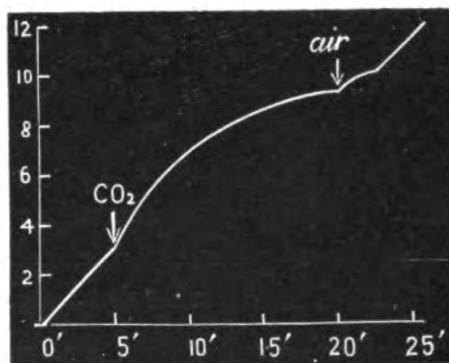

FIG. 192. Effect of Carbonic Acid Gas on Growth

The first arrow indicates introduction of CO_2 , which induces preliminary enhancement of growth, followed by subsequent arrest. The second arrow indicates the introduction of fresh air, followed by the revival of growth. Record taken by Unbalanced Method.

by the slope of the curve becoming horizontal, growth was arrested fifteen minutes after the introduction of carbonic acid into the plant chamber. On the re-introduction of fresh air the growth was slowly renewed, and gradually returned to its original rate. The effect of carbonic acid on growth-response, then, is a preliminary exaltation, followed by depression and arrest, which arrest, if the action be not too long continued, proves to be only temporary.

Action of ether.—This experiment shows the curious difference of results which occurs, according as an application is external or internal. In this and in the following cases, with the exception of the experiments on acids and alkalis, I shall use the Balanced Method, as this brings out even transient variations in a very striking manner. The balanced horizontal record is seen to the left of each figure. In curve *a* of fig. 193 is shown the effect of an *external* application of this reagent, ether vapour being introduced into the plant chamber. It will be seen that there was an immediate retardation of growth, which lasted for more than a minute. This was followed by an acceleration of growth, which lasted for two minutes. There was then a depression, which continued, and culminated in the arrest of growth.

In *b* is shown the effect of an *internal* application, made by replacing the water, by which the cut end of the stem was normally surrounded, with a 3 per cent. solution of ether. It will be seen that, as the specimen sucked up the solution, the immediate effect of this internal application was an enhancement of the rate of growth, and that this was followed by depression, leading to arrest of growth. The preliminary depression seen in *a* is thus wanting in the case of the internal application. It might be thought that this first depression, as seen in the case of the external application, was due to a slight cooling, caused by the introduction of ether. We know, however, that while lowering of the temperature, as long as that is below the optimum, would suffice to retard growth, a similar lowering of it when above the optimum would have the opposite effect of acceleration. Now I find that this preliminary retardation of growth, seen in fig. 193, *a*, takes place in exactly the same manner when the experiment is repeated with the specimen at 38° C. It cannot, therefore, be due to the suggested cooling, which must in any case, under the experimental conditions, have been extremely slight. There is, however, another explanation, which more nearly meets the requirements of the case. We know that any sudden variation of environmental conditions is apt, generally speaking, to act as a stimulus, and the effect of direct stimulation is always to

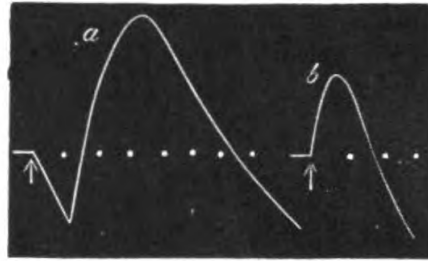

FIG. 193. Balanced Records of Effect of Ether on Growth. Up Curves represent Acceleration Above, and Down Curves Retardation Below, the Normal

a Effect of external application, and *b* of internal application of ether. Successive thick dots in the baseline indicate time in minutes in this and following records. Arrow shows moment of application.

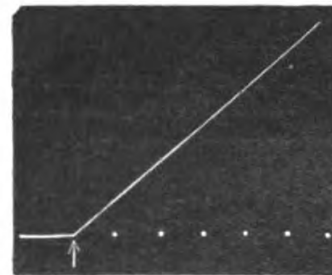

FIG. 194. Excitatory Effect of Dilute Solution of Sodium Carbonate on Growth

induce contraction, which would in the present case take the form of a transient retardation of growth.

Effect of solution of sodium carbonate.—In the course of the following experiments the chemical reagents are administered internally, by applying the solution at the cut end of the specimen. A dilute solution of sodium carbonate is known to increase excitability in the case of animal tissues. I find that this holds good in the case of the growth-response of plants, growth being accelerated, as will be seen in fig. 194, where the balanced record suddenly gives place to an ascending curve. But in the case of chemical reagents in general, and of this especially, it must be remembered that the strength of the solution, or dose, is an important element in the result. A 5 per cent. solution of sodium carbonate was always found in these experiments to be an excitant; but as the strength of the solution was increased, the excitatory effect was found to be gradually diminished, until at

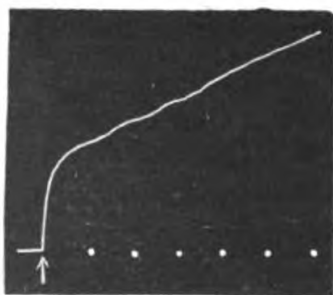

FIG. 195. Acceleration of Growth by Application of Solution of Sugar

2 per cent. it became neutral. If now the strength were still further increased, say to 5 per cent., the effect was an actual depression of the rate of growth.

Effect of solution of sugar.—I next give a record (fig. 195) showing the effect of the application of sugar in a 2 per cent. solution. This is seen to induce a responsive acceleration of growth. In the case of the *Crinum* Lily, this acceleration is found to occur even under a 5 per cent. solution of sugar; but very much stronger solutions induce depression.

Effect of alcohol.—We have hitherto observed different reagents inducing a more or less uniform acceleration or depression. In the case of alcohol, given in 5 per cent. solution, however, we obtain a very curious instance of alternating spasmodic effects (fig. 196); that is to say, the growth at one moment exhibits a sudden acceleration, and

at the next a sudden depression, such alternations being continued for a considerable length of time. On repeating the experiment at the higher temperature of 34° C. I found that these spasmodic alternations became still more violent—that is to say, of greater amplitude, though less frequent. At a much higher temperature, however, the effect of alcohol was an immediate depression. Still stronger solutions caused arrest of growth at all temperatures.



FIG. 196. Spasmodic Alternations of Growth under Alcohol

Effect of acids.—We found, in the case of the autonomous responses of *Desmodium*, as of cardiac muscle, that acids induced relaxation, and that the long-continued action of such a reagent, or a strong solution, would bring about arrest in the relaxed position. Curiously enough, then, in the case of growth, which I have shown to be an instance of multiple or autonomous response, I find an effect exactly parallel. In order to hasten the result I used a somewhat strong solution, namely 4 per cent., of hydrochloric acid. This, as will be seen (fig. 197), caused a marked relaxation, and growth came to a standstill some six minutes afterwards. In this experiment, and the following on the effect of alkali, the record was taken under unbalanced conditions.

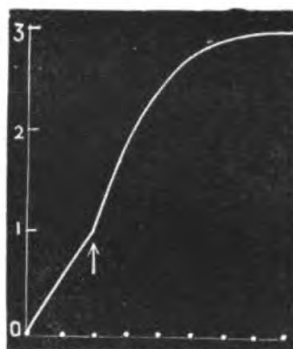

FIG. 197. Unbalanced Record showing Action of Acid in Causing Relaxation and Ultimate Arrest of Growth

Effect of alkali.—The effect of alkali in the case of *Desmodium*, and also of cardiac muscle, is to produce arrest in the contracted position; a similar effect is strikingly exhibited in the growth-record given in fig. 198. The first part of this record shows the normal rate of growth. A 3 per cent. solution of sodium hydrate was then applied at the point marked with the downward arrow (\downarrow). It will be noticed

that this induces a very great contraction, and that in the course of seven minutes there occurs an arrest of growth, in a contracted position. It will also be seen that the specimen,

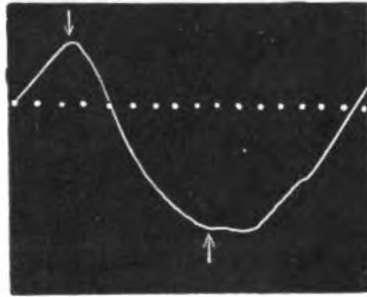

FIG. 198. Unbalanced Record showing the Action of Alkali, and the Antagonistic Action of Subsequent Application of Acid

The downward arrow (↓) indicates application of alkali, which induces arrest of growth in contracted position. The upward arrow (↑) indicates application of acid, which by its antagonistic action renews growth.

after the application, actually became shorter than it had been before. The alkali therefore had the effect not merely of arresting growth, but also of causing an *active* contraction of the tissue.

Antagonistic action of alkalis and acids.—

We saw that in the autonomous responses of *Desmodium* and cardiac muscle, the state of standstill induced by the action of either acid or alkali was neutralised and counteracted by the antagonistic action of the other (cf. fig. 155). I have detected precisely the same peculiarity in the case of growth-response also. It was seen

in the course of the last experiment that growth was brought to a state of standstill, in the contracted position, by the action

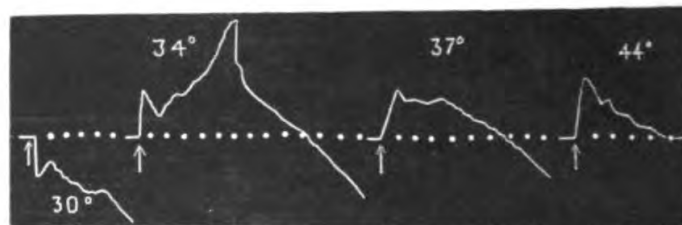

FIG. 199. Effect of Strong Solution of NaCl on Rate of Growth, as Modified by Different Constitutions of Specimens

At a temperature of 30° C. there is an immediate depression. Near the optimum there is a well-marked resistance, and preliminary acceleration before depression sets in. The same is true to a less extent at 37° C. These records were taken under balanced conditions. At 44° C. there was normally no growth, but this was temporarily initiated under the action of strong NaCl solution. Record taken by Method of Balance.

of alkali (fig. 198). At this point, as marked by the upward arrow (↑), acid was applied. This reagent now had the effect

as will be seen from the record, of neutralising the previous contractile arrest, and in the course of two minutes it had brought about the renewal of growth.

Action of strong solution of sodium chloride.—In the course of the investigation on suctional response we noticed that the effect of this reagent, when applied to the root, was not always to cause a diminution of suction, as might have been expected had osmotic action been the only factor. This reagent, on the contrary, usually operated to bring about a preliminary acceleration of suction. And I have already explained that this was due to its excitatory character, acting in opposition to the osmotic action set up by the strong solution. It is usually supposed that the excitatory effect of strong solution of salt on animal tissues is due to the osmotic withdrawal of water; but we have here seen that similar excitation is induced in vegetable tissues without any withdrawal of water. Hence the usual theory of the action of salt solution in causing excitation is rendered very doubtful. We found, in fact, that when the tonic condition of the tissue was favourable, the excitatory reaction predominated, and there was a consequent enhancement of suctional activity. In other instances, where the tonic condition was less favourable, osmotic action predominated, and there was a consequent depression of the normal rate of suction (p. 385). It is thus seen that the factor of variation in these two different cases was the constitution, or tonic condition, of the plant; we are now able to study with precision the influence exercised by constitution, in causing the plant to struggle against, or succumb to, the action of adverse external circumstances. The action, in causing variation of suction, of a strong solution of salt, applied internally through the cut end of the stem, can also be studied by means of growth-response; for while increased suctional activity will give rise to a positive turgidity-variation, with concomitant enhancement of the rate of growth, diminished suctional activity will have the opposite effect, of retarding the rate of growth. We shall next observe the effect of this reagent on different specimens

of *Crinum* Lily, which had been taken from the same flower-head, and in which different constitutions were artificially induced by carrying out the experiments at 30° C., 34° C., 37° C., and 44° C. The records were taken under balanced conditions.

On making an application of a solution so strong as 10 per cent. to a specimen at the normal temperature of 30° C., the result was always a depression which set in immediately ; but when the tonic condition of the plant was exalted, by raising the temperature to a point near the optimum—that is to say, to 34° C.—the same reagent was found to induce an excitatory effect, its depressing action being postponed for a considerable length of time. The effect obtained at the temperature of 37° C. was very instructive. Responsive excitability at this temperature has been shown to be almost the same, if not indeed slightly lower, than that at 30° C. But we should remember that in these two cases we have very different histories ; for if in the former—that is, at 30° C.—we have a normal amount of latent energy, then it is clear that in the latter—that is to say, at 37° C.—there must be an excess of latent energy. And as the result of this we see that, while at 30° C. the growth-response showed immediate depression, at 37° C. it offered a considerable resistance, as seen in the temporary exaltation of response. Still more interesting, however, was the effect at 44° C. At this temperature it will be remembered that there was an apparent arrest of growth, often supposed to be due to the setting-in of heat-rigor. I have shown, however, that, so far from this being the case, there is still at 44° C. a good deal of rhythmic activity, the cessation of growth being due to the fact that in the multiple response of growth each constituent response and recovery had become equal. The presence of this activity at 44° C. becomes quite clear, when we find that the application of salt at this temperature has the effect of renewing for a time the resultant growth which had been in abeyance (fig. 199).

Effect of poisonous solution of copper sulphate.—The influence of constitution in determining resistance to adverse

circumstances is made still more striking when we observe the action on the plant of strongly poisonous reagents, such as 5 per cent. solution of copper sulphate. At the normal temperature of 30° C. its application, as will be seen in the record (fig. 200), induces a very rapid depression, which soon culminates in permanent arrest. But at 34° C. the resistance offered is considerable, actually exhibiting itself in temporary exaltation. At 44° C., again, we observe the poisonous reagent actually initiating growth, as in the last case.

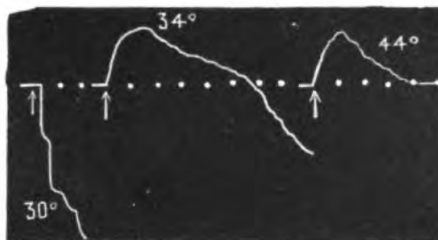

FIG. 200. The Effect of Different Constitutions in Determining the Resistance Offered to Poisons. The Action of 5 per Cent. Solution of Copper Sulphate

Opposite effects of the same dose on different constitutions.—In the case last considered, we studied the phenomenon of the resistance offered by the plant to a toxic dose largely in excess of the fatal amount. In spite of the excessive dose we found that, when a favourable constitution was artificially induced, the plant succumbed, it is true, but only after considerable struggle. I shall now proceed to show how, when the artificial constitution is sufficiently favourable, the plant, instead of succumbing to an ordinarily fatal dose, can shake off the effect, and may even be stimulated by it. Thus I found that a 1 per cent. solution of copper sulphate induces depression and is ultimately fatal at 30° C. ; but when the same dose is applied to a plant at 34° C. the effect is seen in a marked exaltation (fig. 201), which continues for a fairly long period, after which it shakes off the effect of the poison altogether, and resumes its normal rate of growth.

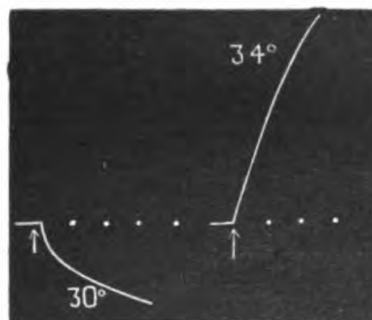

FIG. 201. The Effect of Favourable Induced Constitution in Enabling Plant to Shake off Result of Toxic Dose of Copper Sulphate

Opposite effects of large and small doses.—I have shown the toxic effect of a 1 per cent. solution of copper sulphate at the normal temperature of 30° C. If, however, the dose be reduced to .2 per cent. we shall find that its action becomes stimulatory (fig. 202). This is an interesting illustration of the general fact that a poisonous reagent, if given in sufficiently minute doses, will act as an excitant.

In conclusion, a survey of the effects of drugs, both stimulatory and poisonous, reveals the striking fact that the difference between them is a question of quantity. Sugar,



FIG. 202. Opposite Effects of Large and Small Doses of Poison

A solution of 1 per cent. copper sulphate produces depression and death, but .2 per cent. exercises stimulating action.

for instance, which is stimulatory when given in solutions of, say, 1 to 5 per cent., becomes depressing when the solution is very strong. Copper sulphate again, which is regarded as a poison, is only so at 1 per cent. and upwards, a solution of .2 per cent. being actually a stimulant. The difference between sugar and copper sulphate

is here seen to lie in the fact that in the latter case the range of safety is very narrow. Another fact which must be borne in mind in this connection is that a substance like sugar is used by the plant for general metabolic processes, and thus removed from the sphere of action. Thus continuous absorption of sugar could not for a long time bring about sufficient accumulation to cause depression. With copper sulphate, however, the case is different. Here, the constant absorption of the sub-toxic stimulatory dose would cause accumulation in the system, and thus ultimately bring about the death of the plant.

SUMMARY

Chemical reagents are found to have the same effect on the response of growth as on ordinary response, or as on the autonomous response of *Desmodium gyrans*.

Carbonic acid gas induces a preliminary acceleration, followed by retardation and arrest of growth. On re-admission of fresh air growth is revived.

Ether, when applied internally, causes a preliminary acceleration, followed by retardation and arrest of growth. Minor differences of effect may be observed if the application be made externally.

A very dilute solution of sodium carbonate is an excitant, and accelerates growth; but stronger solutions cause retardation.

Solution of sugar also stimulates growth, if the strength of solution be not excessive.

Alcohol causes spasmodic alternations of growth. Too strong a solution arrests growth.

As in the case of autonomous response of *Desmodium*, so in the response of growth also, acids and alkalis are found to have antagonistic effects. Acid causes relaxation and ultimate arrest of growth; alkali causes arrest of growth in the contracted position. The arrest brought about by one of these agents may be counteracted by the other.

The reaction of a specimen to a chemical reagent is determined by the strength of the dose, and by the duration of application.

A stimulating agent if given in too strong a dose causes depression. A poisonous reagent, again, if given in a sufficiently small dose, acts as an excitant.

A clear insight into the nature of 'constitution,' so called, as a factor in determining the reaction of a specimen to a given drug, is afforded by the induction of definite artificial constitutions. This may be carried out by subjecting the plant to four different typical temperature conditions—the ordinary, the optimum, post-optimum, and maximum.

It is then found that a plant which has been made to acquire excess of internal energy can struggle against, or even overcome, the influence of such adverse circumstances as

the action of poison, whereas under ordinary circumstances it quickly succumbs.

The nature of the response is thus seen to be determined in a definite manner by the constitution, or tonic condition, of the plant, this factor being in its turn dependent on the sum total of the energy which is latent in the organism.

PART VII
GEOTROPISM, CHEMOTROPISM AND
GALVANOTROPISM

CHAPTER XXXVI

THE RESPONSIVE CURVATURES CAUSED BY GRAVITY. NEGATIVE GEOTROPISM

Statement of the problem of apogeotropic response—Mode in which stimulation is brought about : radial-pressure theory, and theory of statoliths—Mechanics of responsive movement—Experiment demonstrating responsive curvature as brought about by unilateral pressure of particles—Record of curvature induced by gravitation—Record of different rates of curvature when specimen is held at angles of 45° and 135° to the vertical—Determination of the true character of apogeotropic response—Responsive curvature of acellular organs—Curvature of grass haulm under gravity—Growth of grass haulm on a klinostat.

IT is well known that growing organs exhibit certain directive movements under the influence of gravitation. Horizontally laid shoots, for example, bend upwards, or against the direction of gravity; while roots react in precisely the opposite way—that is to say, they bend so as to lie in the direction of the force of gravity. In the case of the various forms of stimulation hitherto studied, the action of the plant is well defined and intelligible, consisting of concavity of the excited side, in response to a stimulus which is clearly understood. But in the case of geotropism the mode in which stimulation is brought about is not quite evident, and we find, moreover, two directly opposed effects brought about by apparently the same force of gravity: in the root, as already said, a positive movement, that is to say a movement in the direction of gravity; and in the shoot a negative movement, away from the direction of gravity.

The seeming impossibility of explaining effects so divergent as due to a single common cause, has led to the modern idea that these responsive movements are 'executed at the suggestion of changes in the environment, not as the direct

and necessary result of such changes ;' or in other words that 'light and gravitation could be classed together as external agencies acting, not directly, but in some unknown indirect manner.'¹

There are two distinct points to be borne in mind in connection with the effect of gravity: first, the question as to how gravity exercises stimulation; and secondly, that of how, in answer to this stimulus, a definite responsive curvature is induced.

Mode in which stimulation is brought about.—Now it is clear that, as regards the former of these points, the only conceivable way in which gravity could produce stimulation

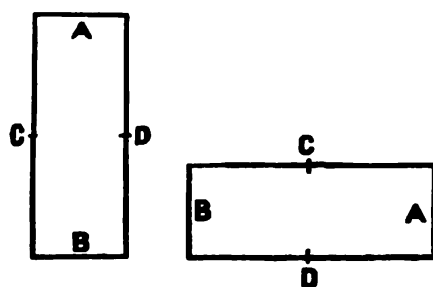

FIG. 203. Diagrammatic Representation showing Differential Effect of Weight on Lateral Walls of Cells

In the figure to the right the cell is laid horizontally, and the lateral wall, D, has to bear greater weight than C (after Francis Darwin).

is by the effect of weight; not, that is to say, by the weight of the plant as a whole, but by the differential effect of weight in the cells. Two important theories have been advanced which offer very rational explanations of the means by which gravi-perception may be induced. According to these, the necessary differential weight-effect may be due to the weight of the cell-contents, whether of the

sap itself, or of those heavy particles like starch-grains which are contained in it. When, therefore, the cell is laid horizontally, it is the lower tangential wall which has to support the relatively greater weight (fig. 203). This theory of hydrostatic or radial pressure was suggested by Pfeffer, and supported by Czapek. The other theory, of *statoliths*—advocated by Noll, Haberlandt, and Nemèc—substitutes for the weight of the

¹ A luminous *résumé* of our present state of knowledge on this subject, with all its difficulties and obscurities, is contained in the addresses of Francis Darwin delivered before the British Association in 1891 and 1904. From these I have made the quotations which appear in the text. Figs. 203, 204, and 209 appear as illustrations of the latter address in *Nature* of September 8, 1904.

water-column the weight of certain relatively heavy bodies, such as starch-grains, differentially exercised upon the lower tangential walls. In the case of multicellular plants, laid horizontally (fig. 204), EE and E'E' may be regarded as regions in which stimulation is caused by the weight of the particles.

The effects produced on the upper and lower halves are evidently antagonistic, and in spite of this we obtain in the case of shoots a resultant curvature upwards. This shows that the stimulation of one half must be greater than that of the other. The inequality must be due to this difference, that the statoliths in EE rest on the inner, and in E'E'

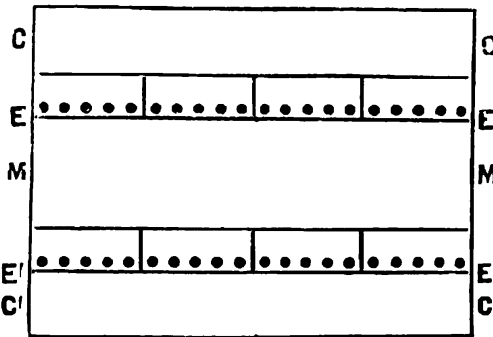

FIG. 204. Diagrammatic Representation of a Multicellular Organ

On the upper side the statoliths act on the inner, and on the lower side on the outer, tangential wall (after Francis Darwin).

on the outer, tangential wall. It would thus appear that one of these must be less excitable than the other.

Mechanics of responsive movement.—From these hydrostatic or statolithic differences of weight, bearing on the ectoplasm of the cell, it is understood that gravi-perception arises, that is to say that the plant perceives the direction of gravity. But there is no explanation as to how stimulation is produced; nor is there any satisfactory explanation as to the mechanics of the responsive curvature. It is generally supposed, as has been said, that this curvature is not the direct and necessary result of some environmental change, but that it is an instance 'of a plant reading a signal and directing its growth' accordingly. It is supposed further that in an apogeotropic cell the curvature takes place by the development 'of relatively accelerated growth on the side on which the pressure is greatest.'

This view, that the curvature induced in some unknown way in a geotropic organ, by gravitation, depends upon the

accelerated growth of the convex side, is apparently supported by Elfving's experiments on grass haulms in which growth had been at standstill. 'He found that the pulvini of grass haulms placed on the klinostat increase in length. This experiment shows incidentally that the klinostat does not remove but merely distributes equally the geotropic stimulus; also that geotropic stimulus leads to increased, not to diminished, growth. The same thing is proved by the simple fact that a grass haulm shows no growth in its pulvinus while it is vertical, so that when curvature begins (on its being placed horizontally) it must be due to acceleration on the convex, since there is no growth on the concave side in which retardation could occur.'¹

In the cases of response to stimulation, hitherto studied, however, it will be remembered that the fundamental effect was always a contraction and concomitant retardation of growth, the expansion and acceleration of growth being always a secondary and indirect effect; but in the case of the response to stimulus of gravity, the interpretation of results which has just been quoted would make it appear that the responsive action brought about by gravity was essentially distinct in its character from the responsive reaction with which we have hitherto been familiar.

Experiment demonstrating responsive curvature as brought about by unilateral pressure of particles.—My own object in the course of the present chapter is, however, to demonstrate the fact that the curvature of an apogeotropic plant-organ in response to gravitation is the result of the direct effect of stimulus, its reactive peculiarities being in no way different from those other instances of the response of the plant to stimulation, which we have already studied. And in order to simplify my explanation, I shall here

¹ *B.A. Report*, 1891, p. 671. It ought to be mentioned here that in other plants when placed on the klinostat this increased rectilinear growth was not observed, leading to the supposition that in such cases a simultaneous increase and decrease of growth-rate on opposite sides of the rotating plant is produced. *Ibid.*; *Nature*.

describe a typical experiment showing the excitatory effect of pressure in inducing responsive curvature. That unilateral pressure or contact does induce curvature is known in the case of tendrils; but in the present experiment I shall show that this responsive reaction is not peculiar to tendrils alone, but is exhibited by all organs alike. I was also desirous of making the action on my experimental specimens in every way parallel to that of gravitationally excited tissue in which the statolithic particles exert their weight on a particular side of the responsive organ.

I took a specimen of *Crinum* Lily and mounted it vertically. I next took a thin strip of india-rubber, the inner surface of which was studded with iron particles, adhering by means of shellac varnish. This was adjusted laterally, on one side of its zone of growth, so as almost, but not quite, to touch the specimen. On the opposite side was placed an electro-magnet, which when excited attracted the strip to which the iron particles adhered, and thus produced a unilateral pressure on the specimen, the magnetic particles functioning as so many statoliths (fig. 205). A recording microscope, which will be fully described in a later chapter, was now focussed on the index, I, attached to the specimen.

Before the application of pressure, the quiescent condition of the specimen had been ascertained by noting the stationary position of the index in the field of view of the microscope. On now applying unilateral pressure by exciting the magnet, we might expect to obtain two different effects. The first of

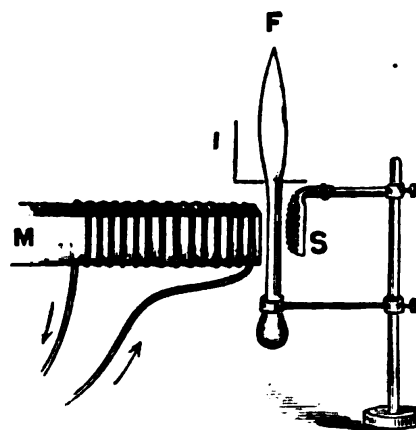

FIG. 205. Diagrammatic Representation of Experiment showing Curvature Induced by Unilateral Pressure Exerted by Particles

F, flower-bud of *Crinum*; S, india-rubber strip studded with iron particles attracted by electro-magnet, M, causing unilateral pressure on growing region; I, index attached to flower.

K K

these would be the sudden magnetic pull which would cause a movement of the flower *away* from the pressed side. This effect would be instantaneous, and quickly come to a stop. The second would be the excitatory effect on the specimen of the unilateral irritation caused by the pressure of the iron particles. If this response, like response in general, were to take the form of a contraction, a curvature concave to the source of stimulus would be produced, by which the flower should be seen to bend *towards* the stimulated side. This stimulatory effect, unlike the mechanical disturbance, would go on increasing with time. In this way it is easy to demonstrate that unilateral irritation of pressure of particles induces contraction, which in growing organs retards the

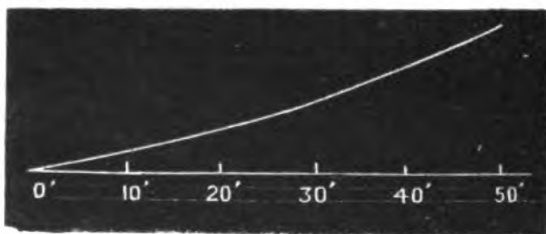

FIG. 206. Record of Responsive Curvature induced in *Crinum* under Experimental Conditions shown in fig. 205. Magnification twenty-five times

normal rate of growth, the side acted upon thus becoming concave (fig. 206). It should also be borne in mind that in consequence of this responsive contraction some of the expelled water finds its way to the opposite side, thus increasing its turgidity, with consequent acceleration of rate of growth and convexity of that side. The experimental proof of this latter phenomenon will be given in the next chapter. Moreover, in consequence of the curvature induced by this contraction of the excited side, the further side will be stretched, and tension is, as we know, an agent tending to increase the rate of growth. Thus we see that in this case the contraction of the excited side is the *active* factor, and the convexity of the further side is the secondary or subsidiary effect in the growth-curvature.

If then such stimulation by unilateral weight-effect, whether statolithic or hydrostatic, be the cause of the apogeotropic curvature induced by gravitation, it follows that the active factor in the process lies in the contraction of the upper side,

and that the expansion and convexity of the lower must be merely the subsidiary effect. But it is usually supposed, as we have seen, that the predominatingly active factor in these gravitation-curvatures is the accelerated growth of the convex side. Hence the crucial experiment by which the correctness of one hypothesis or the other may be determined will evidently consist in demonstrating which of the two, contraction or expansion, is actually the essential element in the responsive growth-curvature. And if, further, we should succeed in proving that contraction was the essential element, we should then have established a unity, as between the phenomena of response to gravitation and those which are the results of other forms of stimulation. But before I describe this particular investigation I must explain the method of continuous record, which I employ for observing gravitational curvatures.

Record of curvature induced by gravitation.—We have in the Optical Lever a means by which the responsive effect of gravitation-curvature and its variations may be recorded quickly and continuously, and with as great a magnification as is desirable. The horizontally laid specimen, say the scape of *Urtica* Lily, has its terminal upper end attached to one arm of the Lever, the other arm being weighted with a slight counterpoise. A continuous record is then taken, on a revolving drum, from which we obtain the responsive curvature and its time-relations. It will be seen from the record that the scape first bent down during a period of forty minutes, after which the effect of gravitation was seen by the reversal of the curve, which indicated the curving up proper to gravitation (fig. 207).

It is sometimes thought that this preliminary lapse of time before the appearance of the gravitation-effect, sometimes known as the presentation time, is the interval necessary for the statoliths to fall; but I shall presently describe some experiments which will show that the time taken for *variation* in response to the varying action of gravitation is very much shorter, probably less than a minute. In the present case we

K K 2

must remember that the movement in response to gravitation has to overcome opposite mechanical movements before it can be made perceptible at all; for we have, firstly, the weight of the organ, which tends to make it bend down; and secondly, on account of this bending, we have greater tension on the upper surface, which, as we have seen, increases the

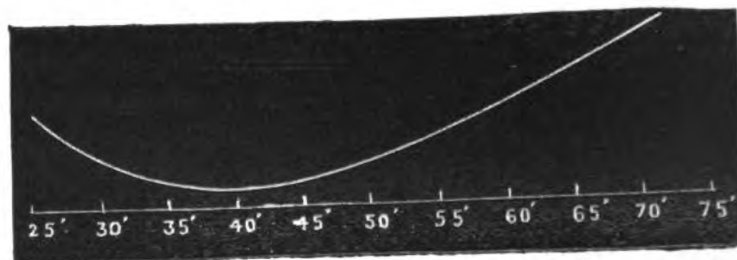

FIG. 207. Record of Apogeotropic Response in Scape of *Uriclis* Lily. The up curvature due to apogeotropic action proper commenced forty minutes after the specimen was laid horizontally.

rate of growth, tending to make that side convex. The differential effect due to gravity has to overcome all this, and becomes visible only when it has done so. After this stage has been reached, the rate of movement upwards goes on increasing until a fairly constant rate is attained.

Record of different rates when specimen is held at angles of 45° and 135° .—Czapek has found that the effective stimulus of gravitation is greater when the organ is held at 135° to the vertical than when held at 45° . This difference of effect can be obtained quantitatively with great accuracy by taking successive records with the specimen in the two positions; and in order to eliminate the effect of any chance disturbance, or of spontaneous variation, I took four alternate records, first with a specimen at 45° , then at 135° , then back once more at 45° , and then again at 135° , each position being maintained just long enough for the attainment of the permanent effect. The change from one position to the other was made quickly, in the course of less than a minute. The experiment was carried out with the unopened flower of *Crinum* Lily, in which we have already found that the rate of growth is very regular and considerable.

The first record was taken after the curvature movement, due to gravitation at an angle of 45° , had attained a constant value. The tip of the flower was then found to be moving at a rate of four divisions per minute. On changing the angle to 135° , the rate of movement showed an immediate increase, and attained in the course of five minutes a permanent rate of 15.5 divisions per minute. It has been said that the experimental adjustment of change of position took only about a minute to effect, yet on renewing the record we find that the effective increase thus established in the gravitation-stimulus was immediately perceived and responded to by the organ, in an accelerated rate of curvature. The permanent increased rate at 135° is thus found to be nearly four times that at 45° . The organ was now returned to its position at 45° , and the rate once more fell till it became nearly equal to what it had originally been at 45° , being only very slightly greater. The organ

was once more placed at 135° , and the rate again rose, till it reached slightly beyond its former value at that angle. The ratio of the second rates determined at 45° and 135° was also found to be almost as 1 is to 4 (fig. 208).

With reference to the cause of this difference of gravitational effect, Haberlandt suggested that it may lie in the fact that the weight of the statoliths in 45° position is on the basal half, while at 135° it is on the apical half (fig. 209). The next point is, to account for the greater reaction of the

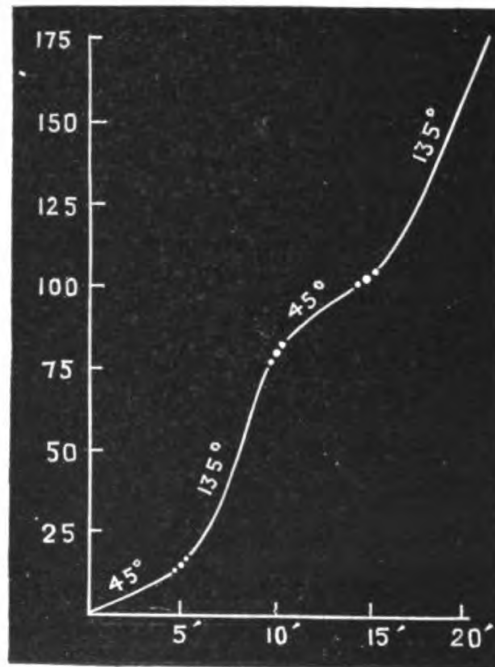

FIG. 208. Response Records showing Differences in Rate of Curvature according as Specimen is held at Angles of 45° and 135°

apical half. Some light may, perhaps, be thrown on this subject from the results of my experiments on *Biophytum*. I found that on subjecting this plant to the favourable tonic

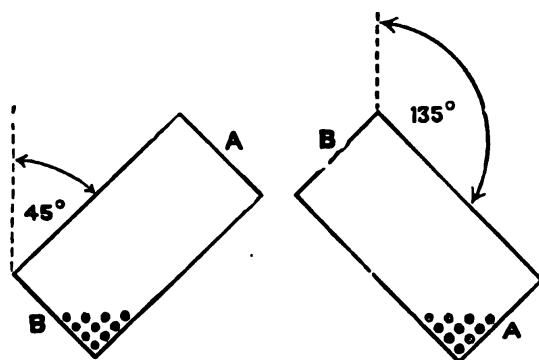

FIG. 209. Diagrammatic Representation of Different Positions of a Single Cell, according as the Specimen is held at an Angle of 45° or 135° , showing Consequent Redistribution of Statoliths (after F. Darwin)

A, apical, B, basal, ends of cell.

condition of rise of temperature, the *younger* leaflets began to show spontaneous excitatory response much earlier than the older leaflets. This shows that in an excitable tissue the younger portions are, generally speaking, the more sensitive. This will probably account for the difference of geotropic reaction in

the case under consideration, for the apical halves of the cells are relatively younger than the basal halves.

Determination of the true character of apogeotropic response.—I shall now proceed with the crucial determination of the true nature of gravitational response. In the diagrammatic representation of the multicellular organ, we have the upper and lower responding layers of cells represented by E and E' (fig. 204). Each of these may be one or more layers in thickness. Since in apogeotropic organs the curvature is upwards, this response may be due (1) to the relative expansion or acceleration of growth of the *lower* side, or (2) to the relative contraction or retardation of growth of the upper side. As regards the first hypothesis, the curvature induced in grass haulms has been assumed, as stated before, to have proved that the gravitational response is one of accelerated growth. On the other hand, the curvature may be due to the active contraction of the upper side, the response then being of the same nature as was seen demonstrated by the irritating pressure of the magnetic particles. The crucial experiment in deciding between the two alter-

native hypotheses will lie in determining which factor is actively concerned in the production of responsive curvature. If the lower should prove to be the side actively concerned, then the response will be one of expansion ; the activity of the upper, on the other hand, would demonstrate the contractile nature of the response.

The principle of the mode of investigation which I adopted in order to decide this question will be understood, if we remember that motile response can be abolished temporarily by application of cold. Thus, if we cool the pulvinus of *Mimosa*, it ceases to exhibit any responsive contraction under stimulation. Now, in a horizontally placed organ, if the continued responsive curvature be due to the excitatory contraction of the upper side, then local application of cold on that side ought to arrest it. The application of cold on the lower side, however, should produce little effect. But if, on the other hand, the lower side should be actively concerned in the production of response, then the application of cold on that side would have the effect of arresting the curvature, while its application on the upper would have little or no effect. In connection with this, it should be remembered that a twitch may sometimes be produced by the transient excitation due to sudden variation of temperature, but the effect will be short-lived. The *permanent* arrest of hitherto continuous responsive movement due to gravitational stimulus will only take place when the active side has its power of response abolished by cold.

An experiment carried out in this manner would thus decide the question as to whether it is the upper or the lower side that is actively concerned, and also the question as to whether the gravitational response, like all other forms of response to direct external stimulus, is, or is not, fundamentally one of contraction.

In carrying out experiments on the principle described above, I first took a record of the responsive curvature of a *Crinum* Lily, which was lying horizontally. When a uniform rate of upward movement had been attained, the tip of the

bud moving at a rate of .13 mm. per minute, ice-cold water was applied on the upper surface, by means of a strip of cloth, at the point marked in the figure by a downward arrow (\downarrow) (fig. 210). In consequence of this the movement is seen to be retarded, and in the course of five minutes it came almost to a stop. The cloth was now removed, at the

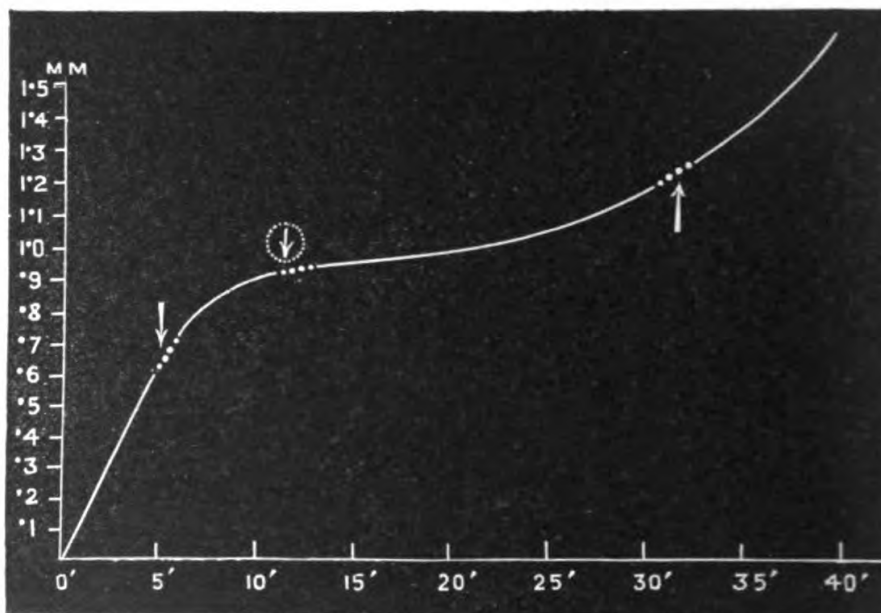

FIG. 210. Effect on Apogeotropic Movement of Application of Ice-cold Water to Upper and Lower Surfaces alternately of a Horizontally-laid *Crinum* Lily

The first part of the curve shows normal up movement, which is arrested in consequence of the application of cold on the upper surface, at the moment marked with a downward arrow (\downarrow). On removal of the application at point marked (⊙), the normal apogeotropic movement is renewed, and continues unaffected by the application of cold below at the moment marked with an upward arrow (\uparrow).

moment marked in the curve, and the movement of response to gravitation recommenced and tended gradually to attain its original value, with the return of the upper surface to the normal temperature. Ice-cold water was next applied on the lower surface, at the moment marked by an upward arrow (\uparrow), and it will be seen that this produced no perceptible effect on the rate of responsive curvature. A similar

experiment was performed with a long flower-scape of *Uriclis* Lily laid horizontally. The attachment to the recording lever was made with the upper end of the specimen, the lower end being held in a clamp. The specimen was 30 cm. long, and the responsive movement was found to be .23 mm. per minute (fig. 211). Here, too, ice-cold water was applied to the upper and lower surfaces alternately, four times in succession, and it will be seen from the figure that an application of cold to the upper surface caused arrest of

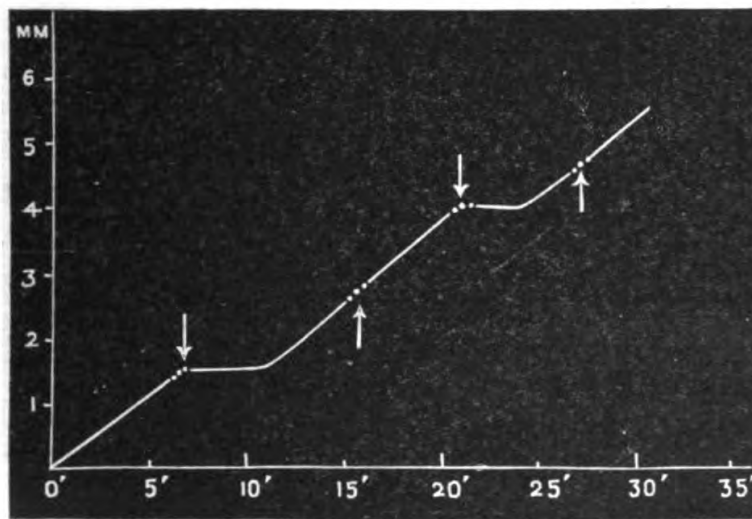

FIG. 211. Effect on Apogeotropic Movement of Temporary Applications of Cold alternately to Upper (↓) and Lower (↑) Surfaces of Horizontally laid Scape of *Uriclis* Lily

Application above is seen to produce arrest of movement, while application below has no perceptible effect.

the responsive movement, while a similar application below produced no effect that could be detected.

These experiments conclusively prove that the fundamental responsive effect induced by stimulus of gravitation is not acceleration, but contraction, or retardation of growth, precisely similar to the action of other forms of stimulus.

Though, under cooling, there cannot be any exhibition of mechanical response to gravitation, yet it appears that the effect of gravitation may be held latent in the organ, as will

be seen from the following experiment. I took three long scapes of *Uriclis* Lily and laid them horizontally, packed in ice. As long as they were in the ice there was no responsive curvature. After an hour they were taken out of the ice and held erect, and by the time that they were restored to the temperature of the room it was found that the top of the scape in each case was bent from 1.3 to 1.5 cm. in the direction of what had been the upper surface when they were horizontal. This was evidently due to the fact that the cold brought about an arrest of growth; but the geotropic stimulus remained latent, to express itself in a responsive movement later, when growth was renewed, under the action of a favourable temperature.

Responsive curvature of acellular organs.—There is one point, in connection with the induction of gravitational curvature, which might at first sight appear anomalous. In the case of the negative geotropic curvatures of multicellular organs, the fact that it is the upper side which is relatively effective, and that the curvature is the result of its responsive contraction and concavity, is evident from the experiments already described on the local application of cold. When we take an acellular apogeotropic organ, however, such as the stalk of the sporangium of *Mucor*, we find that it is the irritated lower side, differentially acted on by weight, whether of sap or statoliths, that becomes *convex*. This looks at first sight as if the effect of irritation were, as it is generally supposed to be, to induce acceleration of growth, and attendant convexity.

We must in this case, however, bear in mind the position of the surface on which the stimulus acts. In our experiment on the irritation produced by the pressure of magnetic particles it was the *outside* surface of the organ that was acted on by stimulus, and it was that side that became concave. In the case of the organ with a single row of cells as described, however, it is the *internal* surface which is so irritated, and if we take as our object of observation that internal surface, we shall find that, as in other cases, so here

also, the response is by contraction and concavity of the excited surface. The convexity of the outer is thus to be taken as the inevitable result of the concavity of the inner.

The fact that in the acellular organ response actually takes place by the concavity to stimulus of the surface acted upon, is further seen in the response of such organs to stimulus of light. In the case of geotropic stimulus it is the *internal* surface of the lower side of the organ which is irritated by the differential weight of the cell-contents, and becomes concave to the stimulus thus acting upon it. In the case of light, on the other hand, stimulus acts from the outside, and it is thus the outer or *external* surface, say, of the same side, which becomes concave. Thus stimulus, acting on the same side in one case from within, and in the other from without, induces responsive curvatures in opposite directions.¹

¹ The explanation of the responsive curvatures of acellular organs has hitherto offered many difficulties. In a multicellular organ, acted on unilaterally by stimulus, there is a difference induced in hydrostatic pressure as between the two opposite sides. The diminished turgidity of the proximal, and increased turgidity of the distal, explains the induced curvature. In an acellular organ, however, there cannot be this difference of hydrostatic pressure on the two opposite sides. But the considerations which I shall now offer may perhaps be found to meet the difficulties of the case. The fundamental effect of stimulus is, as we know, to induce protoplasmic contraction. Hence unilateral stimulation acting on an acellular organ may be expected to induce contraction and concavity of the proximal side of the ectoplasmic layer, the result of which will be a curving over of the organ. As a result of this, the ectoplasmic layer of the distal side will be subjected to tension, which is, as we know, an influence that accelerates growth. Hence the retardation of growth on the proximal, due to contraction, and its acceleration on the distal under increased tension, will combine to produce growth-curvature.

A problem of somewhat greater complexity arises in the case of stimulus of light traversing a transparent acellular organ. Let us suppose such a vertical organ to be acted upon horizontally by rays of light from the right-hand side. We have in this case to consider the separate effects of stimulus of light on four different surfaces: (1) the outer ectoplasmic layer of the proximal side P_o ; (2) the inner ectoplasmic layer of the proximal side P_i ; (3) the inner ectoplasmic layer of the distal side D_i ; and (4) the outer ectoplasmic layer of the distal side D_o . The contractions of the outer surface of the proximal P_o , and the inner surface of the distal D_i , would induce a curvature to the right; those of the inner surface of the proximal P_i and the outer surface of the distal D_o a curvature to the left. But it is evident that as light passes through the organ there must be loss of intensity by absorption. Hence the sum of effective intensities at P_o and

Curvature of grass haulms under gravity.—We shall now take up the consideration of the curvatures induced in grass haulms, laid horizontally, when growth had originally been at standstill. It will be remembered that it was the appearance of curvature under such circumstances in the pulvinus of the grass haulm that gave the strongest support to the theory, that negative gravitational curvature in general was due to the increase in the rate of growth on the convex side, rather than to its retardation from active contraction on the concave. In the present case it was argued that since, at the beginning of the experiment, the upper side of the pulvinus was not undergoing growth, it was clear that growth there could not be retarded. The curvature, therefore, must be due to the induction of growth on the convex side, under the stimulation of gravity.

This misconception has arisen from the supposition that all curvatures must be induced by differential growth. I have shown, however, (1) that contraction takes place in a stationary organ in response to stimulus; (2) that the unilateral stimulation of such an organ induces concavity; and (3) that retardation of growth in a growing organ is itself the result of the contractile effect of stimulus. Now, in a horizontally laid grass haulm in which growth has ceased, the upper side—which we have found to be relatively the more effective—will contract under stimulus of gravity. That this is the case is seen from the fact that this upper surface is found to become actually shorter than it was before. But, as regards the convexity of the lower surface, the water expelled from the actively contracting upper side will reach the lower, and the increased turgidity thus produced is sufficient, as we have already seen, to re-initiate growth in a dormant tissue. This explains the renewed growth and convexity of the lower side. Thus the curvature of the grass haulm cannot be held to support the

at D_i will be greater than the corresponding sum of effects at P_i and D_0 . As the result of this difference we shall have a right-handed or positive heliotropic curvature.

view that the fundamental action of gravitational stimulus is to increase the rate of growth ; it shows, on the contrary, that contraction under stimulation is the active factor.

Growth of grass haulms on a klinostat.—I shall here adduce certain considerations which may further serve to explain the difference between the stationary or feebly growing grass haulms, and other normally growing organs, as regards the effects induced in them by the rotation on the klinostat. It is found that in grass haulms, when subjected to the rotation of the klinostat, growth is recommenced, or increased ; while in other normally growing plants there is no such increase of rectilinear growth. For an explanation of this difference we have to recall the effect on growth of increased internal hydrostatic pressure, with the consequent increase of turgidity, which has already been described (p. 428). It was there shown that, when the plant was growing at a moderate rate, the curve of relation between increase of turgidity and increase of growth was practically a straight line ; that is to say, any increase or diminution of turgidity would then produce a proportionate increase or decrease of growth. But this relation did not hold good when the natural rate of growth was feeble or absent. In the latter cases, increase of pressure induced an effect that was disproportionately large. And this was specially the case when the growth of an organ had come to a temporary condition of standstill. In that case, when the pressure was gradually increased, growth was found at a certain point to be abruptly renewed, and to go on increasing with the increase of pressure, at a rate disproportionately large. If, now, the pressure be once more brought down to what it was just before the point was reached at which growth was started, we find that growth is not arrested, but persists. Thus the net result of these alternations of pressure is a positive resultant growth. We have, thus, two distinct cases: (1) that in which the normal rate of growth is moderate, and in which alternate increase and diminution of pressure, acting for equal lengths of time, will induce equal increase and decrease

of growth alternately, the total growth during the whole of the time being the same as it would have been without alternation; and (2) that in which, the original rate of growth having been feeble or absent, equal alternations of pressure have the net effect of causing a positive increase of rectilinear growth. Now, in an ordinary growing plant, rotating on the klinostat, we have an instance of the first of these two cases; for if at any given moment the side A be below, and the side B above, then B under stimulus of gravity will undergo contraction; hence there will be a diminution of local turgidity, and the expelled water will produce an increase of turgidity on the opposite side A. At the end of a semi-revolution of the klinostat, however, this state of things will be exactly reversed, and the alternating effects being thus equal and opposite, there will be no resultant increase of rectilinear growth; but in the second case—that is to say, of stationary or feebly growing grass haulms—the resultant effect is not *nil*, but a positive increase of rectilinear growth.

SUMMARY

It has been shown that the effect of gravitational stimulus on an apogeotropic organ is fundamentally the same as that of any other form of stimulus, namely, a responsive contraction.

A rational explanation of the mode in which geotropic stimulus acts, is afforded by the radial-pressure theory of Pfeffer and Czapek, or by the statolithic theory of Noll, Haberlandt, and Nemèc—the essential element of both lying in the hypothesis that stimulus is caused by means of the weight of the cell-contents acting differentially on the inner wall of the horizontally placed cell.

That the unilateral pressure of particles is competent to induce responsive curvature of the organ, has been shown experimentally by pressure resulting from the magnetic attraction of iron particles.

It has generally been supposed that the active factor in apogeotropic curvature was the accelerated rate of growth on the convex side of the organ ; but it has here been shown by crucial experiments on the unilateral application of cold, that the active factor is really the responsive contraction and retardation of growth on the concave side.

CHAPTER XXXVII

THE RESPONSIVE PECULIARITIES OF THE TIPS OF GROWING ORGANS

Difference between shoot and root in their response to stimulus of gravity—
Difference in character of response between tip and growing region of root—
Scope of the investigation—Electrical investigation—Responsive results of : 1.
Longitudinal transmission of effect of stimulus from tip ; (a) Moderate uni-
lateral stimulation ; (b) effect of stronger unilateral stimulation—2. Direct
unilateral stimulation of growing region—Moderately strong stimulus—3.
Transverse transmission of effect of stimulus ; (a) moderate stimulation ; (b)
stronger stimulation—Mechanical response inferred from observed electrical
response—Tabular statement.

WE have seen in the last chapter that the responsive effect of gravitational stimulus in an apogeotropic organ is of the same nature as that of any other form of stimulation. In positively geotropic organs like roots, however, this would seem not to be the case, for here the responsive curvature is in the opposite direction. Thus, a root placed horizontally bends in the direction of gravity, and not away from it.

It may be urged that there is some polar difference between shoot and root, on account of which, if the response of the one be regarded as positive, that of the other must be negative ; but I have shown that, so far from this being the case, the response of the root to stimulus is precisely the same as that of all other organs, the shoot included, for all alike under stimulation exhibit contraction (p. 76).

We shall first see, then, whether in the root there is any difference, as regards the action of gravity, from, for instance, the stem. We know that the growing stem with regard to the gravitational stimulus is both the perceptive and responding organ ; for we may cut and isolate any portion of it,

and it will still show an apogeotropic curvature. But the case is quite different with the root. Here the perceptive organ and the responding organ are, as will be seen in the next chapter, distinct and separate from one another.

Difference in character of response between tip and growing region of root.—We shall next turn our attention to the peculiar characteristics of the tip of the root as distinguished from the responding region of growth. Darwin, on applying moderate artificial stimulus unilaterally to the tip of the root, found that it moved away from the source of stimulus; whereas Sachs, on applying similar unilateral stimulus to the responding growing region directly, found that it moved towards it. Thus we see that two different effects are induced, according as stimulation is applied on the responsive zone itself, or transmitted to it from the distant tip; and in this fact we may perhaps find a clue to the explanation of the opposite effects produced by stimulus of gravity on positive and negative geotropic organs.

No explanation has yet been offered of the opposite characters of these responsive effects induced by similar stimuli, according as they are applied on the responsive zone or on the tip of the root. It was suggested by Darwin that 'the tip of the radicle is endowed with diverse kinds of sensitiveness; and that the tip directs the adjoining growing parts to bend to or from the exciting cause, according to the needs of the plant.'¹ These diverse kinds of sensitiveness have in his view been acquired by the tip of the root, for the final advantage of the plant.

The question, then, which we must investigate is, as to whether the peculiar sensitiveness of the tip has been specially evolved by the burrowing root, or is characteristic of the tips of growing organs in general. Should the latter prove to be the case, we have next to account for this characteristic itself. I have already suggested, as a possible explanation of the difference between the responsive actions in apogeotropic and geotropic organs, that in the one case stimulus acts

¹ *Movements of Plants*, pp. 552 and 573.

L L

directly, producing a movement *towards*, while in the other the effect of stimulus is transmitted from a distance, producing a responsive movement in the opposite direction. As against this assumption, however, we are confronted with the fact, which we shall find later, that in some instances of transmitted stimulus of light, the responding organ bends towards, and not away from, the source of stimulation.

Scope of the investigation.—We have therefore to determine (1) whether or not the tips of all growing organs behave alike; (2) why the behaviour of the tip is different from that of the responsive zone of growth; and (3) under what circumstances the transmitted effect of stimulus causes an organ to move towards, and under what, to move away from, the source of stimulation, at the same time ascertaining clearly the mechanics of such movements. For the purpose of this investigation I shall first use the electrical method of inquiry, which I have already fully described, since it has the unique advantage of offering unerring indications under the most difficult experimental conditions; and shall study by its means the characteristic differences of response as between the tip and growing region of a single organ, in this case the shoot.

Electrical investigation.—It will be shown that growth-curvature is produced by unequal variations of turgidity on the two sides of the responding organ. This variation can be detected with great certainty by electrical means. I have already explained how a positive turgidity-variation gives a concomitant electrical variation of galvanometric positivity; and that the true excitatory effect of negative turgidity-variation gives rise to a concomitant electrical change of galvanometric negativity. For the present experiments I took specimens of various growing plants—such as *Bryophyllum*, *Cucurbita*, and others—and the results obtained from all were alike. In order to obtain unmistakable indications of the effect produced in the responding zone, one electrical connection was made at a point in the growing region, A (fig. 212, *a*), and the other with a point so distant

that the effect of stimulation could not reach it. As parenchymatous tissues offer great resistance to the conduction of stimulus, it is an advantage to make this second contact with a leaf. In the present investigation we have to study the effect of unilateral stimulation of varying intensity and duration, when applied either at the tip T, or at C, near the responding point A, the latter being in the same longitudinal line as the excited points T and C. We shall also study the effect of stimulation of A, on the transverse point

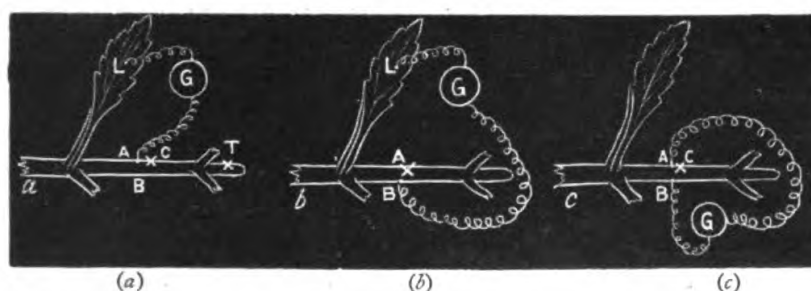

FIG. 212. Experimental Connections for obtaining Electrical Response due to Direct and Indirect Effects of Stimulation

- (a) electrical connections for detection of electrical changes at A, caused by indirect effect of stimulus, from excitation of same side of distant tip, T, and direct effect of stimulus from excitation of adjacent point, C ;
- (b) electrical connections for detection of electrical changes at B, caused by excitation of diametrically opposite point, A ;
- (c) electrical connections for detection of relative electric variations of diametrically opposite points, A and B, due to excitation of C, adjacent to A.

B (fig. 212, *b*), and the resultant effects on A and B, when the point C, near A, is stimulated (fig. 212, *c*).

Before proceeding further, it will be well to consider the theoretical conclusions to which we are led from the demonstrations already made of the turgidity-variations caused by stimulation. The tip T consists, as we know, of undifferentiated tissue, which is a relatively bad conductor of stimulation. Moderate stimulus, then, at T, might be expected to induce local excitatory contraction, and the water thereby expelled would originate a wave of positive turgidity-variation ; this would reach A, a point on its own line, with greater effect than the transversely placed B. The moderate stimulation of T would thus produce a positive turgidity-variation

L L 2

at A on its own side. This transmitted effect of increased turgidity we have already distinguished as the *indirect* effect of stimulation.

But all cells conduct stimulus more or less efficiently, the difference being one only of degree. Hence an indifferently conducting tissue, such as that of the tip, will conduct the true excitatory state only if the stimulation be sufficiently strong and long continued. The transmitted effect of this true excitation may then be expected to produce negative turgidity-variation, and concomitant galvanometric negativity, at A.

When the stimulus is applied, however, at or near the responding point A, we may expect to obtain the *direct* effect of stimulation—that is to say, a negative turgidity-variation and the concomitant galvanometric negativity.

To sum up, then, it may be expected that moderate unilateral stimulus applied at the tip T will give rise on the same side of the responding region to the indirect effect of stimulation, which is an increase of turgidity exhibited by a positive electrical variation. The direct effect of stimulus, whether immediate or transmitted, always produces a negative turgidity-variation, evidenced by galvanometric negativity. This effect may be obtained either by the local application of moderate, or by the distant application of strong, stimulus.

In making the electrical investigation which is now to be described, I employed various forms of stimulation—thermal, mechanical, chemical, and the stimulus of light. Mechanical stimulus may be applied by friction of emery paper, or by means of a pin-prick. Chemical stimulation is applied by touching the point with a brush which has been moistened in hydrochloric or sulphuric acid. Very dilute acid produces moderate, strong acid a more intense, stimulation. The most perfect mode of stimulation is by means of incident light, the intensity of which may be varied at will. The effect of stimulus of light, however, will be fully described in the chapter on heliotropism. Another form of stimulation which is also very suitable is the thermal. A short piece of platinum

wire, heated by electrical current, is placed in the neighbourhood of the point to be stimulated. The intensity of stimulus in this case is regulated by varying either the strength of the heating current, or the distance of the heating wire from the point to be excited. All the different forms of stimulation will be shown to produce the same results.

Responsive results of : 1. Longitudinal transmission of effect of stimulus from tip : (a) *Moderate unilateral stimulation.*—Using the thermal mode of stimulation applied at T (fig. 212, a), I obtained positive electric-variation at A, the record of which is given in fig. 213. A similar result was obtained

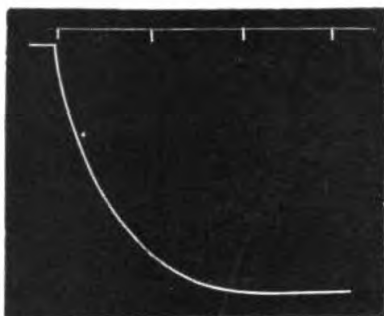

FIG. 213. Record of Positive Electrical Variation, indicating Positive Turgidity-Variation (represented by Down Curve), induced in Growing Region by Moderate Stimulation on same side of Tip. Time-marks = minutes



FIG. 214. Record showing Galvanometric Positivity subsequently Neutralised under Transmission of True Excitatory Effect, due to Continuance of Moderate Stimulation of the Tip

with the mechanical stimulation of a pin-prick. The same was again observed on effecting stimulation by dilute acid.

(b) *Effect of stronger unilateral stimulation.*—I next produced a somewhat stronger thermal stimulation by suitably increasing the heating current. This gave rise to the electrical indication of the preliminary positive turgidity-variation, as the immediate effect. But the long-continued action of the stimulus caused the transmission of the true excitatory, which, reaching A, caused the neutralisation of the previous effect (fig. 214). With another specimen, I next applied to the tip a still stronger unilateral stimulus. This caused a brief positive electrical and turgidity variation, followed by a reversed response of

galvanometric negativity, thus proving that the strong excitatory effect transmitted to the organ had not only neutralised, but also reversed, the previous effect (fig. 215).

2. **Direct unilateral stimulation of growing region:** *Moderately strong stimulus.*—When stimulus is applied near the responding organ, say at C (fig. 212, a), there is always



FIG. 215. Record showing Neutralisation and Reversal of Electrical Response at Responding Region, under Strong Stimulation of Tip

This indicates that the first positive turgidity-variation, due to indirect stimulation, is converted into negative turgidity-variation of transmitted true excitation.



FIG. 216. Record showing Negative Electrical Response represented by Up Curve, indicating Negative Turgidity - Variation due to Direct Stimulation

produced at A a negative electrical, indicating a negative turgidity, variation (fig. 216).

Thus we have obtained, using the same moderate stimulus, two opposite effects, of positive and negative turgidity-variations, according as the point of application was at the distant tip or in the vicinity of the responding organ. It is evident, moreover, that there is a continuity between these two extreme effects, for, as we gradually shift the point of application from the distant point nearer to the responding organ we observe corresponding intermediate changes, from pure positive, through the neutral, due to equal positive and negative effects, to pure negative.

3. **Transverse transmission of effect of stimulus:**
 (a) *Moderate stimulation.*—We have seen that the direct application of stimulus at a point has the local effect of a negative turgidity-variation. It is of great theoretical importance that the effect of this stimulus on the diametrically opposite point should be clearly demonstrated. As conductivity has already been shown to be very feeble across a tissue (p. 250), we might expect that it would be the indirect effect, that is to say the positive turgidity-variation, which on stimulation of A would reach the diametrically opposite, or distal, point B. The experiment is carried out, by making galvanometric connections with B and L, and applying stimulus at A (fig. 212, *b*).

On now applying moderate stimulus at A, we obtain a positive electrical response, indicating positive turgidity-variation, at B (fig. 217)—a result precisely the same as was obtained by stimulating the distant tip. The effect, then, of stimulating any point is to induce a negative turgidity-variation of the point itself, and a positive turgidity-variation of the diametrically opposite point.

(b) *Stronger stimulation.*—When stronger stimulus is applied, however, at A, the true excitatory effect is gradually transmitted across the tissue, and we obtain at B the neutralisation of the preliminary positive effect, as in fig. 214. And, lastly, when the point A is very strongly stimulated, the responsive effect on the diametrically opposite point B is a transient positive, followed by a strong negative variation, as in fig. 215.

We have thus studied the separate effects produced at A and B by stimulation of a point near A. The differential

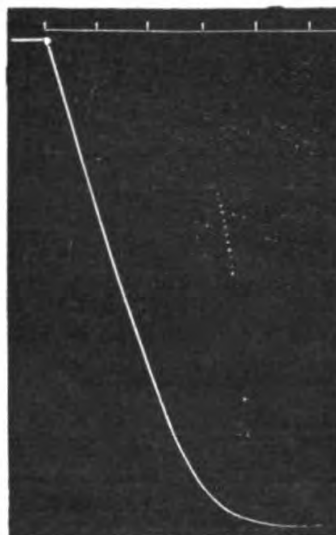

FIG. 217. Record showing Positive Electrical Variation indicating Positive Turgidity-Variation of Distal Point, under Moderate Stimulation of Proximal

effect as between A and B can be inferred by the algebraical summation of these separate effects. Or it can be directly obtained by making electrical connections with the diametrically opposite points A and B, as in fig. 212, *c*, and applying gradually increasing stimulus at C near A.

It will be remembered that these opposite effects of direct and indirect stimulation have received independent demonstration, in both mechanical and growth responses. In *Biophytum* and in *Artocarpus* the positive turgidity-variation was proved to be the indirect effect of stimulation, by the erectile responses of the motile organs (pp. 24, 420). In the case of growth-response, again, the indirect effect of stimulation, with the concomitant positive turgidity-variation, was shown in the increased rate of growth (p. 430). The effect of direct stimulation in inducing a negative turgidity-variation, again, was exhibited in *Biophytum* and *Artocarpus*, by the responsive depression of the motile organs. In the case of growth-response, it was exhibited by contraction and concomitant retardation of growth.

Mechanical response inferred from observed electrical response.—From the results of the electrical investigation on these turgidity-variations, induced by direct and indirect effects of stimulus, as just described, we are led to conclude that :

1. (a) Moderate unilateral stimulation of the tip gives rise by longitudinal transmission to the *indirect* effect of stimulus, namely a positive turgidity-variation, on the same side of the distant responding-organ. This will give rise to acceleration of growth and convexity of that side, and by the consequent responsive movement the tip will be carried *away from* the source of stimulation.

(b) When the unilateral stimulation of the tip is a little stronger, the indirect effect of stimulus is neutralised by the subsequently transmitted true excitatory effect, and there is no resultant action.

Very strong unilateral stimulation of the tip gives rise by longitudinal transmission to the *direct* effect of stimulus, namely a negative turgidity-variation, on the same side of

the distant responding organ. This will give rise to retardation of growth and consequent concavity of that side, the tip being carried, by the responsive movement, *towards* the source of stimulation.

2. (a) Stimulation of a point at or near the responding region of growth will induce a negative turgidity-variation as the direct effect of stimulus, and at the diametrically opposite point a positive turgidity-variation as the indirect effect of stimulus. This will give rise to concavity of the proximal with convexity of the distal sides. The mechanical effects of negative turgidity-variation on one side and positive turgidity-variation on the other side are thus additive. In this way, the concavity of the proximal and convexity of the distal conspire to bring about the resultant curvature.

(b) When the stimulus applied at A is stronger, the effect is a negative turgidity-variation at A, and later, owing to the transmission of stimulus across the tissue, the positive is succeeded by a negative turgidity-variation of B. The resultant effect obtained by algebraical summation thus tends to become zero. When the stimulus at A, however, is still stronger and of longer continuance, the negative response of A will be found to undergo a gradual diminution owing to fatigue, while the transmitted effect at the diametrically opposite point undergoes an increase. Under these circumstances the responsive negative change at B will predominate over that at A. The final result may thus be a relative negativity of B, that is to say an effect opposite to that seen

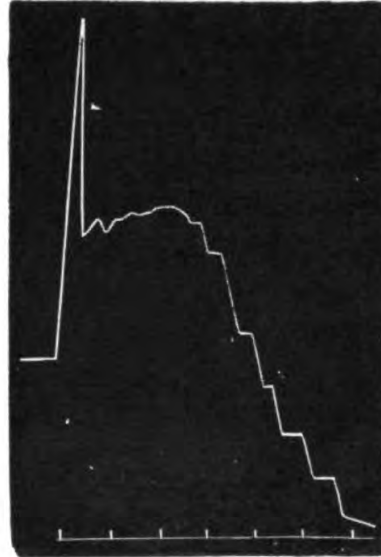

FIG. 218. The Relative Electrical and Turgidity Variations of two Diametrically Opposite Points, A and B, when Strong and Long-continued Stimulus is applied near A (cf. fig. 212, c).

We see here (1), in the up curve, the negative variation of the proximal, followed by (2) neutralisation, followed by (3) reversal, that is to say, relative negativity of B. Note the multiple response which here makes its appearance.

in case (a). These different phases of the effect induced by long-continued application of strong stimulus at A—namely the relative negativity of A, followed by neutralisation, followed by reversal or relative negativity of B—are well seen in the record given in fig. 218. Translated into terms of the resulting mechanical response, this would mean : (1) a movement of the organ towards the stimulus ; (2) neutralisation of this movement ; and (3) a pronounced movement away. I give here a tabular statement which shows at a glance the various electrical effects and the corresponding mechanical responses which are theoretically to be inferred from them, the experimental verification of these inferences being given in the next chapter.

TABULAR STATEMENT OF ELECTRICAL EFFECTS AND INFERRED MECHANICAL RESPONSES

Stimulation	Electrical and turgidity effects in the responding region	Mechanical response theoretically inferred
1. Unilateral, of tip, on side A : (a) Moderate stimulus.	Positive electrical and positive turgidity variation of same side A.	Convexity of A, and movement of tip away from stimulus.
(b) Stronger stimulus.	Positive and subsequent negative effects neutralise each other.	No resultant effect.
(c) Very strong and long-continued stimulus.	Positive twitch, followed by strong negative electrical and turgidity variations, of same side, A.	Transient twitch away from, followed by strong movement towards, stimulus.
2. Direct action of stimulus on responding region : (a) Moderate stimulus.	Negative variation of side acted upon, and positive variation of diametrically opposite side.	Concavity of the excited, with convexity of the opposite side. Responsive movement of organ towards source of stimulus.
(b) Stronger stimulus.	Positive and subsequent negative effects neutralise each other.	No resultant effect.
(c) Very strong and long-continued stimulus.	Positive twitch, followed by strong negative electrical and turgidity variations of the opposite side, B.	Resultant mechanical response opposite to that in 2 (a) ; i.e. movement away from the stimulus.

The verification of these theoretical inferences will be given in full in the following chapter.

SUMMARY

From electrical investigation we find that the responsive peculiarities of the tip of the root are not characteristic of that organ alone, but of the tip of the shoot also.

The different effect between stimulation applied to the tip and to the growing region of an organ lies in the fact that from the former—it not being a good conductor of excitation—only the indirect effect, that is to say the positive turgidity-variation, is transmitted to the responding organ. In the latter case, however, direct excitation gives rise to negative turgidity-variation.

Moderate unilateral stimulation of the tip, therefore, gives rise on the same side of the responsive region to increased turgidity, which, translated into mechanical response, means a negative curvature or movement away from stimulus.

Stronger and long-continued stimulation of the tip causes transmission of the direct effect. This will gradually neutralise or even reverse the first effect, the positive turgidity-variation giving place to negative. These events translated into terms of mechanical response mean a change from negative to positive response, or movement towards stimulus.

Direct unilateral stimulation of the responsive region causes negative turgidity-variation of the proximal and positive turgidity-variation of the distal. The mechanical expression of these will be a movement towards stimulus.

By strong and long-continued action the stimulus ceases to be unilateral and becomes internally diffused. The excitation thus reaches the distal side. The difference of turgidity-variation on the proximal and distal is thus gradually abolished, or even reversed. The corresponding mechanical response will be a neutralisation or reversal into negative, that is to say a movement away from the stimulus.

CHAPTER XXXVIII

INQUIRY INTO THE LAWS OF RESPONSIVE GROWTH-CURVATURES

Scope of the investigation: 1. Mechanical response to unilateral stimulation of the tips of shoot and root: (a) Moderate stimulus—(b) Stronger stimulation—2. Effect of unilateral stimulus, applied at the responding growing region: (a) Moderate stimulus—(b) Strong or long-continued stimulus—Experiments on the direct and indirect effects of stimulus on *Mimosa*: (a) Direct stimulation—(b) Indirect stimulation, longitudinal transmission—(c) Indirect stimulation, transverse transmission—The curious response of an *Aroid*—Table showing responsive effects common to pulvini, pulvinoids, and growing organs—Laws of responsive growth-curvature.

WE were able, at the end of the last chapter, to pass in review the theoretical conclusions to which we had been led by the electrical mode of investigation, as to the responsive movements which might be expected to follow on the unilateral application of stimulus to the tip and the growing region respectively. I shall now proceed to submit these theoretical conclusions to experimental verification, by taking records of the mechanical movements actually induced.

It will be understood here that my object is (1) to show that the peculiar response given by the tip of the root is characteristic of the tip of the shoot also; and (2) to demonstrate the effect of unilateral stimulation on the growing region. We have therefore to study the effects which are induced at the growing region by the action of stimuli of different intensities, according as they are applied unilaterally at the distant tip, or, locally, on the growing region itself. As a specimen of the shoot-tip, we may employ either the tip of a stem or that of an unopened flower-bud. This latter, composed mainly as it is of indifferently conducting elements,

has all the characteristics of the tip of the organ, while the peduncle below often represents the area of quickest growth, and functions as the responding region. Another advantage of the unopened flower-bud, again, lies in the fact that its upper end is not covered over with appendages like that of the stem. The unopened buds, with peduncles, of *Crocus*, then, will be found suitable for this investigation. As specimens of the roots, again, the long straight water-roots of Bindweed are very suitable for these experiments.

The records of the responsive movements are taken by means of the recording microscope fully described in a subsequent chapter. The quiescence of the organ, before the application of stimulus, is tested by the fact that the record is a horizontal line. The occurrence of an up curve in the record represents responsive movement towards, while a down curve means movement away from, the stimulus. In this investigation, as in the preceding, various forms of stimulation have been employed. Mechanical stimulus is applied by friction of emery-paper. The jar produced by this causes a temporary disturbance of the image in the field of view of the microscope; but this soon subsides, and the excitatory movement commences after a short latent period, increasing steadily until the effect of stimulus is exhausted. The chemical form of stimulation has the advantage of producing no mechanical jar. The stimulation produced by light, which is the most perfect, will be described in the subsequent chapter on heliotropism. Thermal stimulation is effected by holding a platinum wire, heated by the electrical current, in more or less proximity to the point in the tissue which is to be excited.

1. **Mechanical response to unilateral stimulation of the tips of shoot and root:** (a) *Moderate stimulus*.—Applying a single mechanical stimulus of emery-paper friction, of moderate intensity, unilaterally to the bud of *Crocus*, a movement was induced in the responding organ, which carried the tip away from the source of stimulation. This movement persisted for four minutes, after the application of this single

stimulus. I performed a similar experiment on the tip of the root of Bindweed, the response being precisely the same. The rate of movement was in this case somewhat slower, but persisted for eight minutes. The application unilaterally of dilute sulphuric acid brought about exactly similar results in both cases. The unilateral application of thermal stimulus of moderate intensity, again, to the tip, induced movement away

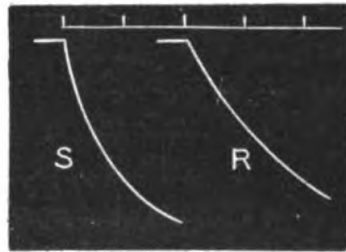

FIG. 219. Mechanical Responses of Shoot, S, and of Root, R, to Unilateral Stimulus applied at the Tip

In this and following records the down curve indicates negative movement or away from source of stimulus. The up curve indicates positive or movement towards source of stimulus. The time-marks represent minutes (cf. fig. 213).

ferred the occurrence of a convexity on that side, which would carry the tip away from the source of stimulus. The direct effect of stimulus next reaches the responding region, reversing the first effects and causing a negative turgidity-variation, which would, *pari passu*, induce a concavity, and carry the tip towards the source of stimulation.

In carrying out the experimental verification of these mechanical movements on a bud of *Crocus*, I found that an application of strong sulphuric acid on one side of the bud caused it to move first away from, and then very energetically towards, the direction in which the application was made. I next tried to determine the effect of a strong unilateral application of thermal stimulus on the root-tip of Bindweed.

from the source of stimulation in both shoot and root, as will be seen from the record given below (fig. 219).

(b) *Stronger stimulation.*—A somewhat stronger stimulation of the same character caused a movement away, followed by movement towards, the source of stimulus, the resultant effect being neutral. We now pass on to the effects induced by still stronger stimulation. I have already explained how, when very strong stimulus is applied unilaterally at the tip of an organ, its first and transitory effect is to induce a positive turgidity-variation on the same side of the growing region. From this we in-

Here, too, after a transient movement away, there was an energetic movement towards the stimulating heated wire (fig. 220).

2. **Effect of unilateral stimulus applied at the responding growing region.**—I shall now show that when stimulus is applied near the growing region, it induces effects which are opposite to those resulting from stimulation of the tip.

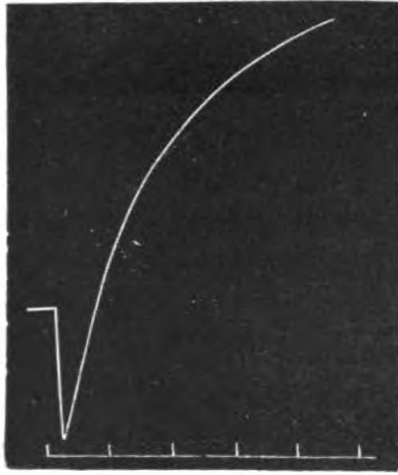

FIG. 220. Mechanical Response of Root of Bindweed to very strong Unilateral Stimulation applied at the Tip

This causes a preliminary negative, followed by a positive, movement, that is to say towards the source of stimulus (cf. fig. 215).

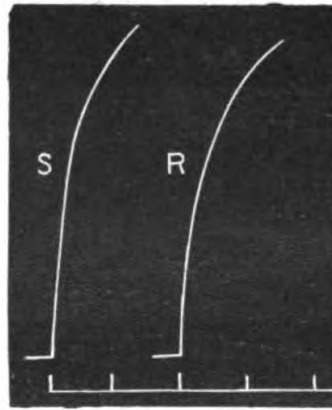

FIG. 221. Mechanical Responses of Peduncle of *Crocus*, S, and Root of Bindweed, R, to Unilateral Thermal Stimulation at the Growing Region

The responses are positive and towards the source of stimulus (cf. fig. 216).

(a) *Moderate stimulus.*—When moderate stimulation of any kind is applied unilaterally in the growing region, the consequent negative turgidity-variation of the side directly excited makes it concave; and a positive turgidity-variation due to the indirect effect of stimulation occurs at the distal side, making that side convex. Thus the induced concavity of the proximal, and convexity of the distal, both conspire to cause a movement of the organ towards the source of stimulation. This is seen in the following records obtained with the peduncle of *Crocus* and the root of Bindweed, the stimulus used having been thermal (fig. 221).

(b) *Strong or long-continued stimulus.*—I have already explained that with moderate stimulation the negative turgidity-variation and concomitant contraction of the proximal, and the positive turgidity-variation and concomitant expansion of the distal, conspire to induce a positive responsive curvature; but when the stimulus is strong or long-continued the excitation is conducted across the tissue to the distal side, which, now contracting, antagonises and reverses the action of the proximal. We have seen this exemplified in the electrical response given in fig. 218, where the first positive electrical response of the distal, indicating positive turgidity-variation, was afterwards neutralised and converted into negative by the transverse conduction of excitation.

In the case of responsive growth-curvature we obtain results precisely similar. Long-continued unilateral stimulation is here often found to neutralise the first or normal effect. Or if, again, the unilateral stimulation be very strong, the proximal side is liable to become fatigued, and the response of the distal to transmitted stimulus being thus predominant, a responsive movement occurs which is reversed or *negative*, that is to say, away from the source of stimulation. Examples of this will be seen in Chapter XLII. I shall also presently give a demonstration of similar preliminary effects with subsequent transverse conduction, giving rise to reversed effects, in the case of the motile response of *Mimosa*.

We have thus seen that growth-curvature is induced by unequal variations of turgidity, on the diametrically opposite sides of the growing region. We have seen that the effect of indirect stimulation is a positive turgidity-variation. When a feebly conducting tissue is unilaterally subjected to moderate stimulation, the direct excitatory effect cannot be transmitted far, and it is the indirect effect which reaches the responding region, R (fig. 222), and induces convexity. Hence we obtain the typical examples of this effect by stimulating the tip, τ , of either root or shoot. The sensibility of these regions is itself in no way different from that of any other portion of

the plant-tissue, for they respond to direct external stimulation by contraction. But their power of transmitting stimulus is relatively feeble. For this reason, under ordinary circumstances, they transmit only the indirect effect of stimulus, and it is only when the unilateral stimulus is very strong that the direct excitatory effect is transmitted, inducing the opposite to the usual result, in the responsive concavity of the same side of the growing region.

The fact that the sensitiveness of the tip is not fundamentally different from that of the growing region may be demonstrated by applying stimulus to a given point D in the growing region, and observing the responsive effect induced at R, diametrically opposite. The power of the tissue to conduct stimulus transversely being feeble, the result is in this case the same as in that of the ordinary longitudinal transmission from the tip; that is to say, it is the indirect effect that reaches the diametrically opposite point, R, and induces convexity there, this effect being aided, as it happens, by the concavity of the proximal side, due to the direct effect of stimulation. Here again, as before, a stronger or long-continued stimulus may later transmit the direct effect, and neutralise or reverse this first responsive curvature. A third case arises when unilateral stimulus is applied at L, lower down on the stem, at some distance from the responding region, and if this be sufficiently feeble, it will be the indirect effect which will reach the same side of the responding region, and produce convexity there. Stronger or long-continued stimulation will in this case, as before, neutralise or reverse the first effect.

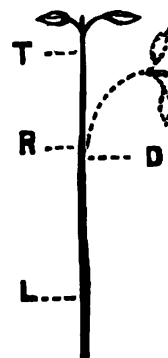

FIG. 222. Diagram showing the various Responsive Effects induced at the Growing Region, R

When moderate stimulus is applied unilaterally at the tip, T, or distant point, L, it is the indirect effect that reaches R, and produces convexity. The same convexity of R is induced by stimulation of the transverse point, D; but here the induced curvature is aided by the concavity of the directly excited D.

M M

I have been at some pains to make these examples of the direct and indirect effects of stimulus clear; for all the complex curvatures of growth, which appear at first sight so anomalous, are ultimately resolvable into these. And since the subject is so important, I shall add still another demonstration, which is capable of easy repetition, and will be found to be striking and convincing.

Experiments on the direct and indirect effects of stimulus on *Mimosa*.--We have now seen that all growth-

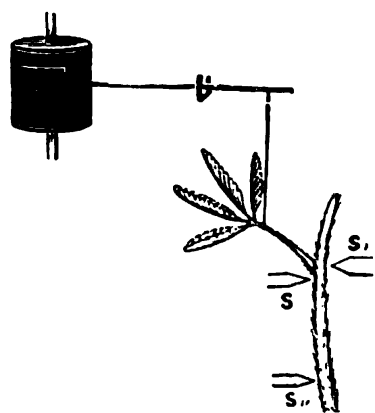

FIG. 223. Experimental Arrangement for obtaining Records on Smoked Drum of Responses given to Direct and Indirect Stimulation by Leaf of *Mimosa*

Thermal stimulator at s produces direct stimulation, and consequent fall of leaf. Moderate stimulation, at a distant point, s'' , gives rise to indirect effect of erection.

curvatures may be analysed into, (1) that contraction, with consequent concavity, which is concomitant to the negative turgidity-variation that constitutes the direct, or transmitted direct, effect of stimulus; and (2) that expansion, with consequent convexity, that is concomitant to the positive turgidity-variation, which constitutes the indirect effect of stimulus. Now, the negative turgidity-variation is exhibited in the case of the motile leaf of *Mimosa* by depression, and the positive turgidity-variation by erection.

I shall now explain the experimental arrangements by which the plant itself may be made to record these opposite effects. The indicating leaf is attached to the short arm of a long writing lever. This lever consists of the quill of a long tail-feather of a peacock. Its short arm, 1 cm. in length, is tied by a thread to the petiole of the leaf. A fine needle is passed through the quill, and rests on frictionless supports which may be glass tubes. The longer arm of the lever, 10 cm. in length, has a piece of bent aluminium, with a sharp point, tied to the end,

to serve as a writer. This writing-point is, by the elasticity of the feather, pressed lightly against the smoked-paper surface of a vertical revolving drum (fig. 223).

When the leaf is under no stimulation, either direct or transmitted, the record is a horizontal line. But true excitation produces a depression of the leaf, causing an up curve. The erectile response, on the other hand, which is due to indirect stimulation, produces a down curve. The records given in the following figures are accurate reproductions of some which were taken in this way (fig. 224).

(a) *Direct stimulation.*— Stimulus is applied by the close proximity of a V-shaped platinum wire, heated electrically. Its intensity is varied by varying either the distance of the stimulating wire or the intensity of the heating current. When stimulation is now applied directly at s , that is to say, near the responding organ, response takes place by a negative turgidity-variation, producing a fall of the leaf. This is seen in the up curve (fig. 224, a).

(b) *Indirect stimulation, longitudinal transmission.*— Stimulus of moderate intensity is now applied lower down on the same side of the stem, at s_1 . This is observed first to induce the positive turgidity-variation, causing erectile response, which is due to the indirect effect of stimulus, and is shown in the preliminary down twitch of the curve (fig. 224, b). Later, the direct effect is trans-

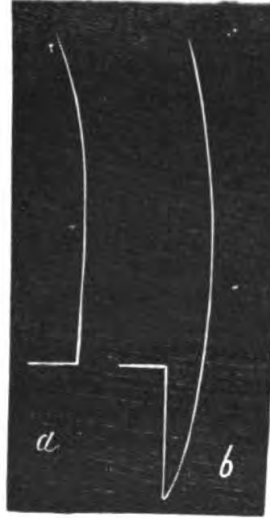

FIG. 224. Mechanical Responses of Leaf of *Mimosa*

(a) record of responsive fall when stimulus applied near the responding organ (cf. fig. 221); (b) response when stimulus is applied on same side, but at greater distance, s_1 . A preliminary erectile response is here followed by the true excitatory depression. This is due to the indirect effect first transmitted being succeeded by the direct. Had the stimulus applied been feebler, or more distant, there would have been only the first, or indirect erectile effect, similar to fig. 225 (cf. fig. 220).

mitted, causing the fall of the leaf, as shown in the up curve. When the stimulus is feebler, or applied at a still greater distance, the indirect effect alone reaches the organ, and only



FIG. 225. Erectile Response of Leaf of *Mimosa* due to Transmission of Indirect Effect to Distal Side, when Proximal, s_1 , is Stimulated

If stimulus were stronger, this would be followed by the fall of the leaf due to the later transmission of true excitation. The response would then become like that of fig. 224 (*b*) (cf. fig. 219).

the erectile response, due to positive turgidity-variation, results, being similar to that shown in the next record (fig. 225).

(*c*) *Indirect stimulation, transverse transmission.*—We next obtain the very interesting case in which feeble stimulus is applied at the transverse point s_1 . The record (fig. 225) shows that we have here an erectile response due to the positive turgidity-variation of indirect stimulation. But if this transverse stimulus be made strong or be long continued, the direct effect is transmitted somewhat later, and, in that case, we obtain a fall of the leaf, preceded by the positive erectile twitch, which is similar to that shown in the previous record (fig. 224, *b*).

The curious response of an *Arisæma*.—This fact will explain a very remarkable phenomenon which I

have noticed in certain species of *Arisæma*, that grow on the mountains round Darjeeling, at a height of about 7,000 feet. This plant, before flowering, consists of a long petiole bearing a terminal whorl of leaflets, which are arranged like rays in a strictly horizontal plane. Later, however, the inflorescence, borne on a peduncle enclosed within its spathe, breaks out from one side of this petiole. Unilateral mechanical stimulation is thus undoubtedly brought about, and gives rise to indirect stimulation on the distal side, which, as we have just seen, causes an erectile mechanical response. In the case of this *Arisæma*, it is a striking fact that immediately after flowering, the most distal leaflet of the whorl—that is to say, the

leaflet which is situated in the diametrically opposite line—hitherto horizontal, becomes abruptly vertical (fig. 226). This is the only leaflet which stands out from its fellows, and it is invariably found to be situated on the line diametrically opposite to the flower, such differentiation being induced only after flowering.

All the variations exhibited by diverse forms of response—electrical, mechanical, responsive acceleration or retardation of growth, and growth-curvatures—are only so many



FIG. 226. Curious Response of *Arisæma*

Before flowering the leaflets lie in a horizontal plane, as seen in the figure to the left; but when inflorescence breaks through unilaterally, the indirect stimulation of the distal side causes erection of the diametrically opposite leaflet, as seen in figure to the right.

expressions of these two fundamental phenomena, the effects of direct and indirect stimulation. It is these two variables which, conjoined with stimulus unilateral or diffuse, give us all those manifold effects that at first sight would appear to belong to different classes of phenomena. That such a unity does actually underlie them all may be seen at a glance from the following concise statement of responsive effects, induced in pulvini, pulvinoids, and in growing regions which act as pulvinoids.

TABLE SHOWING RESPONSIVE EFFECTS COMMON TO PULVINI,
PULVINOIDS, AND GROWING ORGANS

Stimulation diffuse	Stimulation unilateral	
	Effect on proximal side	Effect on distal side
1. DIRECT EFFECT. Negative turgidity-variation. Galvanometric negativity. Depression of motile leaf. Retardation of growth.	3. DIRECT EFFECT. Negative turgidity-variation. Galvanometric negativity. Contraction and concavity. ¹	4. CORRESPONDING EFFECT. Positive turgidity-variation. Galvanometric positivity. Expansion and convexity.
	When stimulus is strong or long continued, the true excitatory effect passes to the distal side, neutralising or reversing the first response.	
	5. TRANSMITTED DIRECT EFFECT. Negative turgidity-variation. Galvanometric negativity. Contraction and concavity, in responsive region.	6. CORRESPONDING EFFECT. Positive turgidity-variation. Galvanometric positivity. Expansion and convexity in responsive region.
2. INDIRECT EFFECT. Positive turgidity-variation. Galvanometric positivity. Erection of motile leaf. Acceleration of growth.	7. INDIRECT EFFECT. Positive turgidity-variation. Galvanometric positivity. Expansion and convexity in responsive region.	8. CORRESPONDING EFFECT. Negligible.

REMARKS.—It will be remembered that the indirect effect is a secondary consequence of the direct contractile effect of stimulus on the excited point. Thus the motive power is the active contraction of that point. The indirect effect, described as No. 7, is exemplified by the moderate unilateral stimulation of the tip of shoot or root. When this stimulus is stronger, or sufficiently long continued, we have a transmission of the *direct* effect of stimulus, and case No. 7 is displaced by case No. 5.

¹ The induction of concavity, of either upper or lower side of the pulvinus, by local stimulation will be found demonstrated in a subsequent chapter.

Confining our attention to the effects induced at the growing region, we arrive at the following laws of growth-curvature.

Laws of responsive growth-curvature.—It must be remembered here that the effect of indirect stimulation is to cause an increase in the rate of growth, and that of direct stimulation a retardation of the rate. By a *positive effect* is meant a responsive mechanical movement towards, and by *negative*, away from, the source of stimulation.

1. **Unilateral stimulus of moderate intensity, applied at the tip of root or shoot, gives rise to a negative effect, the tip being moved away.**

2. **Stronger or long-continued stimulus, applied unilaterally at the tip of root or shoot—being conducted gradually to the growing region—results in a neutralisation of the first negative by a subsequent positive effect. Or there may be a resultant positive, due to the predominance of the transmitted effect.**

3. **Direct unilateral stimulation of moderate intensity on the growing region causes a positive response or movement towards stimulus.**

4. **Strong or long-continued unilateral stimulation of the growing region, on account of the transmission of effect to the distal side, may give rise either to neutralisation of the normal, or to a reversed or negative effect, that is to say, to movement away from stimulus.**

SUMMARY

All the mechanical effects induced at the responsive growing region of either root or shoot, by unilateral stimulation, may be summarised as follows, it being understood that positive response means movement towards, and negative, movement away from, stimulus :

(1) *Positive response* is induced, first, by direct unilateral application of stimulus on the growing region ; second, by the long-continued unilateral application of moderately strong stimulus at the tip.

(2) *Negative response* is induced, first, by the unilateral application of feeble stimulus at the tip ; and second, by long-continued unilateral application of strong stimulus at the growing region, causing fatigue of the proximal, and transmission of true excitation to the distal, side.

CHAPTER XXXIX

INQUIRY INTO POSITIVE GEOTROPISM

No specific difference as regards their responses between shoot and root—
Darwinian curvature—Localisation of geotropic sensibility at the root-tip—
Experiments as to whether amputation of root-tip abolishes excitability—The
tip of the root the organ of gravi-perception—The perceptive *versus* the
responding organ—True perceptive region.

WE have in the course of the last chapter studied in detail the expression in growth-curvatures of the direct and indirect effects of stimulus, and have found them to be, under known conditions, very definite. We have seen that the responsive effects produced at the tips of root and shoot are in no way different from those which have been observed in other parts of the tissue. The specific sensitiveness hitherto so generally attributed to the root-tip is thus found not to be justified. The differences of effect which have been noticed, according as tip or responding region is the point of stimulation, we have seen to be due merely to the transmission of the indirect instead of the direct effect. I shall next proceed to show that the opposite curvatures induced in shoot and root by stimulus of gravitation are really due, not to two distinct sensibilities positive and negative, but to the action of a single stimulus which acts in one case directly, and in the other indirectly.

Darwinian curvature.—It has thus been shown that the responsive curvature manifested by the radicle on stimulation of its tip is not characteristic of roots alone, but, under similar circumstances, of the shoot also. It has not, then, been specially evolved for the advantage of the plant. As proving this, the abrupt conclusion of certain experiments of my own has a peculiar interest. The tip of the root

was in these cases subjected to strong unilateral stimulation by the proximity of a heated platinum wire. Instead of responding, however, by movement away, as would have been the case had the advantage of the plant been the primary object of its action, the root-tip gave only a preliminary spasmodic twitch in the negative direction, and then reversed its movement ; the organ now turned towards the heating wire, fell upon it, and was burnt.¹ There is thus no protective adaptation here, any more than in the case of the moth which is impelled to throw itself upon the destroying flame. No choice exists for either of these, for, in both alike, the movement is due to the working of the inexorable laws which govern the phenomenon of response. In the case of the plant, that increased turgidity which is the indirect effect of a distant stimulus always induces an increased rate of growth ; but when the stimulus is sufficiently strong or long continued, its direct or true excitatory effect, being transmitted, brings about retardation of growth. And each of the diverse curvatures of growth, induced by the unilateral application of stimulus, forms a particular case of the working out of these two laws, of the direct and indirect effects of stimulation.

Having now arrived at certain definite conclusions as to the mechanism of the responsive curvature induced by unilateral stimulation of the tip of root or shoot, it will be well to pass in rapid review the exhaustive series of experiments on the responsive behaviour of the tip of the radicle, which were carried out by Darwin, more especially as some of the cases which he noted as somewhat exceptional will be found, in view of the investigation which I have described, to be susceptible of very simple explanation. He produced unilateral stimulation in three different ways, first, by attaching minute fragments of cardboard to one side of the

¹ The same thing happens, in a still more striking manner, when the wire is placed in front of the growing region, and suddenly heated. The excitatory effect on the proximal side is then so great that the organ at once rushes upon the stimulating wire and is scorched. This occurs before the distal side could be excited by the transmitted effect of stimulus.

root-tip by means of gum or shellac varnish. The moderate and constant irritation which was produced in this way was usually found to induce a convexity on the same side of the growing region. His second method was chemical. He touched one side of the tip with silver nitrate. This also, generally speaking, induced a convexity similar to the last. The third and last method of unilateral stimulation employed by Darwin was a slanting cut, resulting, in the majority of cases, in the same responsive curvature as before. All these cases, it will be understood, are illustrations of the indirect effect of moderate stimulation.

But we have seen—in the second law of responsive growth-curvature—that under the long-continued action of a stimulus sufficiently strong, this first, or negative, effect is neutralised by the subsequent conduction of excitation (p. 52). The degree of such conduction and the power of neutralisation will obviously depend on the conducting power of the particular specimen. Now, it was found by Darwin, in several of his experiments, that the negative effect was followed by neutralisation. This he regarded as somewhat exceptional. We have seen, however, that such a result, under certain circumstances, was to be expected.

We have also seen, in the same law of responsive growth-curvature, that when the transmitted stimulus is strong, it induces a reversed or positive curvature. And in some of Darwin's experiments also, especially those in which he used the strong stimulation of caustic, this was observed.

Finally, in some six cases, Darwin found that on applying unilateral stimulation to the tip there followed an induced concavity. With regard to this it need only be said that the sensibility of the tip to direct stimulation is not specifically different from that of any other tissue. All tissues contract, in response to direct stimulation. The difference between the contractile powers of the tip and the growing region is one merely of degree, that of the latter being relatively greater, and for certain reasons, to be described later, the more evident. Visible contraction

of the tip can only be seen under considerable stimulation, or when that part of the tissue is highly excitable.

Localisation of geotropic sensibility at the root-tip.—

I next turn to Darwin's very important demonstration of geotropic perception as residing in the root-tip. He showed this by extensive researches on the fact observed by Ciesielski, that on the decapitation of the root-tip the geotropic action is found to disappear. Various objections have been urged against this view, which I shall be able to show to be groundless.

Sachs, for instance, has argued that if such sensibility resided in the root-tip, there is no reason why the tip of the shoot should not exhibit the same. This argument is not, however, valid, inasmuch as the statolithic or other elements, which by their weight cause stimulation, may be concentrated locally in the root-tip, and more diffusely distributed in the shoot. And that the general sensibility of the root-tip to other forms of stimulation is not different from that of the shoot-tip I have already fully demonstrated. Francis Darwin has shown, again, that localised gravi-perceptive areas may occur in organs other than the root. In the seedling of *Sorghum*, for example, he finds this sensibility to reside in the cotyledons.

The second objection that has been raised is that the shock of amputation might either abolish the general excitability or arrest the growth of the root, on which the responsive growth-curvature depends. With regard to the abolition of excitability, it is true that the effect of a strong stimulus, such as that of cut, would persist for some time, yet there is always recovery, after a longer or shorter interval. I have tested the persistence of the fatigue caused by amputation, by the electrical method, and I find that with certain plants, such as *Bryophyllum*, the recovery from the effect of amputation-shock is very rapid, taking place in the course of about a minute. The longest persistence of the after-effect which I have been able to observe was in the case of *Colocasia*, where it lasted for a period of

from forty-five to sixty minutes. It is thus unlikely that amputation would permanently abolish the power of renewed response.

With regard, next, to the contention that amputation would be liable to arrest that growth of the root on which responsive curvature is supposed to depend, it is to be borne in mind that though growth-activity is a sign of excitability, yet we may have excitability without growth. Hence it is quite possible that responsive curvature might be initiated in a tissue which was not beforehand in a condition of growth by the stimulus of gravity, as indeed was found to be the case with grass haulms.

Investigation on supposed abolition of excitability by amputation of root-tip.—The question as to whether amputation of the tip abolishes the general excitability of the growing region of the root, can only be decided finally by the direct observation of the variation, if any, in the mechanical response of the root to stimulus after amputation. Should there be no such variation, then—the researches of Ciesielski and Darwin having proved that a root deprived of its tip does not respond to gravity—it will follow that the tip of the root alone is geotropically sensitive. That this is so—that is to say, that amputation does not permanently modify the general sensibility of the root—I shall next proceed to demonstrate.

The experiments that have been carried out by different observers, for the purpose of determining whether amputation of the root-tip produces any modification of the rate of growth, have led to very various results. Some have found that it has the effect of inducing an accelerated rate of growth; others, again, state that it induces no change whatever in the rate; and still others find that it causes retardation of growth. All these discrepancies are reconciled, however, when we remember, as I have demonstrated, that indirect stimulus causes increase, and direct stimulation retardation, of growth. Moderate stimulation, therefore, by section of the extreme tip, giving rise to the transmitted effect of indirect

stimulus, would accelerate growth; while a section made in a better-conducting tissue, or nearer the growing region, with its stronger stimulation, would transmit the direct effect, with concomitant retardation of growth. But a stimulation of intermediate intensity would initiate no change.

I shall, however, describe an investigation by which the question of the variation of responsive excitability in the growing region by amputation is put to the test of direct experiment. For this purpose I mounted a straight water-root of Bindweed in my Crescograph, and took a record of its normal rate of growth. It should be stated that the root was attached to the Optic Lever at a distance of 3 mm. below the tip, which was thus left free for amputation. The normal rate of growth was considerable, being $\cdot 0105$ mm. per minute. I next took a record of three successive contractile responses to thermal shocks (fig. 227). After this, without disturbing the arrangement, the root-tip was amputated, to a distance of 2 mm., and a record of the growth was again taken after an interval of fifteen minutes.

It was now found to be practically the same as before amputation, the rate being $\cdot 0100$ mm. per minute. The contractile responses to thermal shocks of the same intensity as before were also, to all intents and purposes, the same. With another specimen the rate of growth before section was $\cdot 0066$ mm. per minute; after amputation of 3 mm. of tip, the rate was $\cdot 0055$ mm. The mechanical responses before and after section were almost the same. These experiments, then, show that amputation of the root-tip does not abolish the general excitability of the responding region. The fact that the gravitational response of the root, however, is abolished by the removal

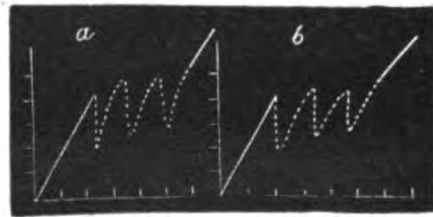

FIG. 227. Curves showing Effect of Amputation on Rate of Growth and Response in Root of *Bindweed*

(a) continuous line indicates normal rate of growth. Dotted curves represent three responses to three successive uniform stimuli; (b) exhibits the rate of growth and responses after amputation. It will be seen that there is practically very little variation.

of the tip, proves that, as pointed out by Darwin, the tip is, with regard to gravity, the perceptive organ of the root.

The tip of the root the organ of gravi-perception.—The inference that it is the root-tip which is the perceptive organ has also been arrived at by Pfeffer and Czapek, pursuing an independent method of investigation which discarded amputation.

There is again the very suggestive fact that the starch grains whose weight, according to the statolithic theory, brings about stimulation, occur generally at the root-tips alone. Thus three different lines of research lead to the conclusion that it is in that region that the gravi-perceptive power resides, the power of response by curvature being behind, in the region of growth.

The perceptive versus the responding organ.—In view of much existing vagueness on this subject, it is desirable here to obtain clear and well-defined conceptions as to how far the differences commonly insisted on between perceptive and responding organs are justified. To take the familiar instance of *Mimosa*, we know that when stimulus is applied, for example, on the stem, there is no perceptible motile effect in the stem itself, but excitation is markedly manifested at the pulvinus. From this it has been erroneously supposed that the stem merely perceived, and did not respond to, stimulus. It has, however, been shown in previous chapters that every part of the plant-tissue responds to stimulus by contraction, the visible and striking manifestation seen at the pulvinus being simply the result of certain accessory anatomical facilities which happen to exist at that point.

Thus, every part of the plant-tissue is both perceptive and responsive to external stimulus, to a greater or less extent. When we come to the growing organ, responsive curvature is induced by the concavity of the excited side. And as the zone of growth is, generally speaking, the region of the greatest excitability, the greatest curvature usually takes place there, that region functioning

in this respect as a diffuse pulvinoid. It should be remembered, however, that the excitability of a tissue does not disappear on the cessation of growth, and responsive curvatures are thus sometimes seen to extend even beyond that zone.

Contraction takes place, as we have seen, in all tissues, but it is relatively much less in the very young and the very old. The responsive contraction at the tip is therefore slight and comparatively inconspicuous. Indeed, it can only be made visible under very strong stimulation. That contraction is induced, however, is shown in the fact that a wave of positive turgidity-variation reaches the zone of growth by excitation of the tip. This can only be brought about by the expulsion of water, which is the result of excitatory contraction at that point. Under direct stimulation, then, every tissue, whether at the tip or in the growing region, undergoes a similar contraction. The sensitiveness, or sign of response, of all tissues is therefore the same ; but about these signs we are liable to be deceived if we pay attention to the conspicuous effects alone, for the local application of a unilateral stimulus at the tip gives rise to little perceptible concavity, while its transmitted indirect effect, lower down in the growing region, induces a relatively great convexity. Moreover, the whole length of the organ above the point of greatest convexity acts as a kind of lever-index, causing high magnification of the responsive movement. The tip, on the other hand, possesses no such magnifying index. These considerations will clearly show that there is no difference in kind between the sensitiveness of the tip and that of the growing region, both alike having the power of perceiving and responding, in different degrees, to external stimulation in general. Just as the tip itself merges physically into the growing region, so these respective responses pass imperceptibly into one another. Though moderate unilateral stimulus of the root-tip causes the characteristic movement away from stimulus, yet strong stimulation induces movement towards it. Stimulus applied on other parts of the plant also will induce movements similar to that caused by mode-

rate stimulation of the tip, provided the effect transmitted to the growing region be indirect.

True perceptive region.—There is a sense, however, in which it is true that the root-tip alone is the perceptive region, but this statement applies exclusively to the stimulation caused by gravity; for, in order that this may take place, the presence of statolithic or other elements through which it can act is necessary. But if such elements be concentrated at the root-tip, it is clear that that region alone can become the seat of stimulation. This is not the case with other forms of stimulus, which act directly, the presence or absence of statoliths being a matter of indifference. This distinction is important, since the outward resemblance of effects at the root-tip, in the two cases of stimulation by light and stimulation by gravity, has sometimes led to the assumption that statolithic bodies formed the medium of excitation in both. That such, however, is not the case is now evident.

In the geotropic root, then, it is the indirect effect of moderate stimulus, unilaterally transmitted from the distant tip, that causes the responsive curvature. In the case of the apogeotropic stem, on the other hand, it is the direct stimulation of the statolithic elements distributed throughout that region that induces the responsive curvature; and since I have shown that the curvature caused by direct is opposite to that which is the result of indirect stimulation, it will be seen that the opposite curvatures observed in root and shoot are not due to different sensibilities possessed by the two organs.

It is to be noted, moreover, that although the statolithic or radial pressure theory affords a very rational explanation of the mode in which stimulation is brought about by gravity, yet the explanation which I have offered, of the occurrence of opposite geotropic effects in root and shoot, does not in any way depend upon the ultimate validity of this or any other particular theory. The aim of my demonstration has been to show that, through whatever means the stimulus of gravity may act, it is inevitable—from the fact

that the stimulation of the shoot is direct, and that of the root indirect—that a single identical stimulus should in the two cases induce opposite responsive effects.

Thus, though for the sake of convenience it is necessary to distinguish the upward curvature of the stem from the downward curvature of the root, by such terms as apogeotropic and geotropic, yet these words must not be allowed to connote two different sensibilities to the action of gravity; for the sensibility of irritable tissues to stimulus is always of one kind, and of one kind only.

SUMMARY

The responses induced by stimulation of the tips of shoot and root are similar under similar circumstances.

The amputation of the tip of the root does not, normally speaking, abolish the excitability of the growing region of the root.

The abolition of geotropic action in the root, after amputation of the tip, shows therefore, as pointed out by Ciesielski and Darwin, that with regard to gravity it is the tip that is the perceptive organ. This conclusion is also supported by the experiments of Pfeffer and Czapek, in which amputation was not included. The statolithic particles, again, through whose weight stimulation by gravity is probably brought about, are, generally speaking, found concentrated at the root-tip.

Direct stimulation has been shown to induce a responsive movement in one direction, and indirect stimulation in the opposite. The opposite geotropic curvatures in apogeotropic and geotropic organs are therefore due, not to the possession of different sensibilities, but to the fact that in the former stimulation is direct, and in the latter indirect.

N N

CHAPTER XL

ON CHEMO-TROPISM AND GALVANO-TROPISM

General difficulties of the investigation—How to overcome these difficulties—

Three distinct methods of testing results: (1) by variation of longitudinal growth; (2) by responsive movement of pulvinus; and (3) by growth-curvature—Method of application of chemical reagent—Effect of alkali—Effect of acid—Effect of copper sulphate—Action of sugar solution—Chemo-tactic movements—Explanation of anomalous osmotic or plasmolytic action—Excitatory *versus* plasmolytic reaction in pulvinus of *Mimosa*: (1) Favourable tonic condition—(2) Ordinary tonic condition—Polar effects of currents inducing growth-curvatures—Localised polar effects on pulvinus—Anodic and cathodic effects on longitudinal growth—Generalised law of polar excitation in plants—Galvano-tropic response—The indirect effect of polar excitation—The effect on growth of 'electrification' of soil.

It will be understood that growth-curvatures take place so slowly, that the effects of various external agents in inducing them can only be observed visually after the lapse of considerable intervals of time, which may be a matter of hours, or even of days. This fact is sufficient of itself to introduce elements of complication into the problem; for (1) the plant may in that time undergo unknown spontaneous variations; (2) the fundamental effect of any given stimulus is subject, when too long continued, to reversal, as we have seen in the case of the leaf of *Mimosa*, which from normal contraction passes into fatigue-relaxation, under the long-continued action of stimulus; (3) the subjection of a plant during too long a period to an abnormal condition may sometimes cause derangement of its general functions; and (4) there is the further element of variation which depends upon the point of application of stimulus itself, since we have seen that stimulation, acting directly on the responding organ, may produce one effect, and indirectly exactly the opposite. It

has doubtless been due to the action of these sources of variation that the observations made by investigators have so often been contradictory.

All these uncertainties disappear, however, when we employ the high magnification, and the method of continuous record, which have been described; for by these means we are enabled to follow the different phases of effect which occur immediately on the application of stimulus, and during its continuation. As these curvatures, moreover, are the results of the unilateral application of stimulus, expressed in the one-sided modification of longitudinal growth, the previous demonstration of the effect of the diffuse application of the same agent on growth itself enables us to infer the result to be looked for. The experiment is thus resolved into a verification of the inference.

Again, I have shown that the growing region acts like a diffuse pulvinoid. Experiments then, by unilateral application of the particular stimulus to a true pulvinus, offer us another and independent means of testing the results arrived at. Thus we have no fewer than three distinct methods of testing the action of a given agent in the induction of growth-curvature, which, if they corroborate each other, may be regarded as affording a rigorous demonstration of the results. These are: first, the variation of longitudinal growth under the diffuse action; second, the responsive movement of a pulvinus under the unilateral action; and, third, the curvature which represents the modification of growth induced by the unilateral action of a given stimulus or agent.

Method of application of chemical reagent.—In dealing with problems involving the unilateral application of chemical reagents particularly, the experimental arrangements which I am about to describe will be found suitable. In order to obviate the complications which might result from the indirect effect of stimulus applied at a distance, the chemical reagent should be applied directly on the growing region. For this purpose the petals of various flowers, while in an active state of growth, are very appropriate, and I have used particularly

N N 2

those of the Indian *Champaca* (*Michelia Champaca*). The claw of a detached petal is held in a clip, and the petal is immersed in the inverted position in a small glass trough of water, of cubical shape. Inside the trough, and almost touching one face of the petal, say with its own right surface, is a partition of mica, in which is a long narrow slit. Thus the petal is in the left-hand compartment of the cube. A microscope of low magnification is focussed on the marginal point of its tip. The required chemical solution is now dropped by means of a pipette into the right-hand compartment. Thus it is diffused through the narrow slit, and acts directly and virtually unilaterally on the proximal side of the petal. If the particular agent should be one which accelerates growth, that is to say induces expansion, a growth-curvature will be induced, the proximal side becoming convex;¹ but if its action is to induce depression or retardation of growth, the permanent effect will be a concavity of the proximal. The movements induced are observed by means of the microscope.

Effect of alkali.—In studying the effect of various drugs on growth in Chapter XXXV. we saw that the characteristic effect of alkali was to produce a contraction and retardation. In the present experiment, on the unilateral application of sodium hydrate in the manner described, the proximal side of the petal was found to become concave, the tip being carried towards the agent.

Effect of acid.—The general effect of acid was found, as will be remembered, to be opposite to that of alkalis, namely relaxation. On now applying solution of HCl unilaterally to a petal of *Champaca*, the result was the convexity of the proximal side.

Effect of copper sulphate.—This I have found to arrest growth, and its unilateral application in the present case was observed to induce concavity of the proximal side of the petal.

¹ The sudden introduction of a reagent may occasionally give rise to a transient excitatory contraction, but the effects described here are the permanent growth-effects.

Action of sugar solution.—A dilute solution of this agent has already been shown to accelerate growth. Its unilateral application was found, in the present case, to bring about convexity of the proximal side of the specimen; but very strong solutions of sugar were found, as we have seen, to retard growth, and the unilateral application of such a solution was now found to induce concavity of the proximal side.

Chemo-tactic movements.—We have now seen that the excitatory or depressing action of various agents is indicated, in the case of the growing organ, by a curvature one way or the other. Similar movements are induced also in pulvinated organs; but in organs which are capable of multiple response we shall expect to find that the corresponding effects induced by such agents will consist in similar movements often repeated—that is to say, in the initiation of such multiple response, or in its appropriate modification. It will be shown in Chapter XLIX. that the swimming movements executed by ciliated organisms form an instance of such multiple response. It will further be shown in that chapter that the organs respond to stimulus, whether chemical, photic, thermal, or electrical, by swimming either towards or away from it.

Explanation of anomalous osmotic or plasmolytic action.—An attempt has sometimes been made to explain the responsive movements of plant-organs as the result of supposed osmotic variations within the tissue. Thus it was held by De Vries that the growth-curvatures of multicellular organs were brought about by an increase of osmotic substances on the convex side, giving rise to augmented hydrostatic pressure. It was afterwards ascertained, however, that the convex side of the curved organ did not contain any greater quantity of osmotically active substances than the concave. The method of plasmolysis of De Vries is often used for the determination of the differential osmotic activity and turgescence on the two sides of a curved organ. After plasmolysis, the curve induced in the organ is flatter than before, and from this it has been inferred that the cell-

sap of the convex side of the organ is more powerfully osmotic than that on the concave.

But various effects have been observed, of which the occurrence of plasmolysis alone affords no explanation. Thus, the diminution of curvature, which De Vries showed to be a consequence of plasmolysis, was demonstrated by Noll, in the case of recently curved organs, to be only the second phase of the effect; for at the beginning of the operation in these cases, as he pointed out, the curvature of the organ was actually increased. This opposition of effects, the increase of curvature, followed by the flattening of the curve, as the result of plasmolysis, has not hitherto met with any satisfactory explanation.

These obscurities in plasmolytic reactions have arisen from the fact that the excitatory action of some of the plasmolysing reagents has not hitherto been recognised. That such an influence may be exercised, and sometimes in opposition to osmosis, was, however, demonstrated in my experiments on suctional response, where it was seen that a strong solution of sodium chloride applied at the roots, instead of arresting suction by the withdrawal of cell-sap, actually enhanced the rate of suction for some time (p. 383). It was also shown in a later chapter, dealing with the effects of chemical reagents on growth, that when favourable tonic conditions had been induced, fairly strong salt solutions, instead of the usual retardation of growth, brought about a temporary enhancement, followed by depression (p. 486). We thus see that the responsive movement is modified (1) by the condition of the tissue, and (2) by the duration of the application of the solution. Now, in an already curved organ, we have an induced anisotropy, or difference of condition, on the two opposite sides. The effects of chemical reagents, then, on such an organ will be complex, for they will differ on the two sides, in intensity, and also in phase of reaction. The observed responsive movement in increasing or diminishing the existing curvature will thus represent the algebraical summation of the effects on the two sides.

Excitatory versus plasmolytic reaction in pulvinus of *Mimosa*: (1) *Favourable tonic condition*.—I have already stated that a moderately strong solution of sodium chloride is a stimulating reagent. It is therefore to be expected that its diffuse application on the pulvinus will bring about a fall of the leaf; and this, as we shall presently see, is found to be the case. We saw, however, in studying the effect of sodium chloride on growth-response, that under the favourable tonic condition induced by the optimum temperature of 34° to 35° C. it gave rise to a preliminary relaxation, followed later by contraction. From this it occurred to me, that in the parallel response of the pulvinus of *Mimosa* we might expect, under similar favourable conditions, to observe two opposite responsive movements: first, a preliminary expansion, exhibited by erection of the leaf, and afterwards a contraction, exhibited by the depression of the leaf.

In carrying out the experiment, I cautiously raised the temperature of the pulvinus to 34° C. and then applied to it a 3 per cent. solution of sodium chloride at the same temperature. The responses were automatically recorded by the leaf on smoked paper wrapped about the revolving drum. It will be seen (fig. 228) that the preliminary effect was a movement of relaxation or erection, which was completed in the course of one minute, and was followed by the opposite movement, or fall of the leaf. In these two opposite responsive movements, then, occurring in succession to each other, we have an analogous case to that of the two opposite and succeeding modifications of curvature, observed by Noll in a curved organ, immersed in salt solution.



FIG. 228. Response of Leaf of *Mimosa* in Favourable Tonic Condition to Chemical Stimulus of 3 per Cent. Salt Solution

The preliminary response is here seen to be erectile.

(2) *Ordinary tonic condition.*—It will thus be seen that inferences drawn from experiments on plasmolysis may lead us to very wrong conclusions unless we take full account of the possible excitatory action of the particular solution. This is made strikingly evident by the following experiment. If we apply a strong solution—say 10 per cent.—of sodium chloride to the pulvinus of *Mimosa*, then, arguing entirely from the theory of plasmolysis, we must expect that the withdrawal of water will cause flaccidity of the tissue, and so bring about the fall of the leaf. This flaccidity, further increasing with the duration of application, would tend also to increase the fall of the leaf progressively. But a similar fall

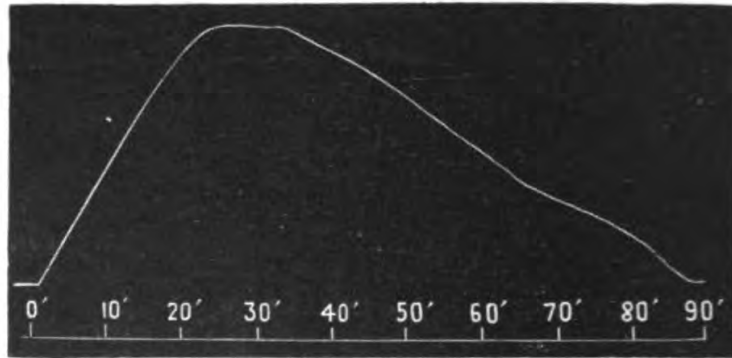

FIG. 229. Response of Leaf of *Mimosa* in Ordinary Tonic Condition to the Chemical Stimulus of 10 per Cent. Solution of Salt Under continuous stimulation the normal responsive fall is followed by fatigue-relaxation.

may, on the other hand, be due to an excitatory reaction caused by strong salt, and there is nothing at first sight which would enable us to distinguish the one from the other. We know, however, as regards *Mimosa*, that under a continuous application of stimulus—as, for instance, rapidly succeeding mechanical or electrical shocks—the first fall of the leaf is succeeded by a return to the erect position. If the predominant effect of salt, therefore, in the given instance, be to induce a responsive fall by excitation, then its continuous operation should give rise to a subsequent erection. And from the automatic curve recorded on the smoked drum this is found to be the case (fig. 229);

for it demonstrates that the fall of the leaf of *Mimosa* under the action of a strong solution of salt was due, not to plasmolytic, but to excitatory action.

Polar effects of currents inducing growth-curvatures.—

The galvano-tropic effects noticed by various observers in the case of growing plant-organs have been contradictory, because of the many complicating factors which might be expected to arise, not only from the differences of anodic and cathodic effects, but also from the varying points of application, and intensity and duration of current. All the obscurities and anomalies in connection with this subject will, however, be found to disappear, when they are related to the fundamental polar effects, which have already been established as applying to the excitation of plant-organs (Chapter XVI.). I have shown that the kathode excites at make, and the anode at break. I shall now be able to show further that the galvano-tropic effects observed are all deducible from these. Incidentally, too, owing to certain special advantages afforded by growth-response, we shall be able to discover additional effects which could not have been detected by the mechanical response of the pulvinus alone. We have hitherto investigated the polar effects of an electrical current acting on the pulvinus as a whole; but in order to bring these fundamental effects into the clearest prominence, and to establish their universality, I shall now study (1) the reaction induced in a limited area of the pulvinus; (2) the variations of longitudinal growth which result from the electrical actions of anode and kathode; and (3) the growth-curvature induced by the unilateral action of anode or kathode on a growing region.

Localised polar effects on Pulvinus.—It is usually believed that the responsive effect seen in a pulvinus is entirely due to the excitability of the lower half of the organ. I have already shown that it is really due to the differential excitability of the upper and lower halves, and that the upper half is also contractile under stimulus, though in a less

degree than the lower. This will be seen fully demonstrated in heliotropic response, where the localised action of moderate light on the upper surface will be found to induce a movement upwards. In the present case, a given electrode, carrying current, will be applied locally on the upper half of a pulvinus, the second electrode being applied at a considerable distance on the stem, and the specific result recorded.

For such local application, it will be understood that a large pulvinus is an advantage, and therefore I used for my experiment the pulvinus of *Erythrina indica*, the sensitiveness of which is not so marked as that of *Mimosa*. As preventing the diffusion of stimulus to the lower side, this lessened sensitiveness of the organ constitutes an added advantage for the purposes of my experiment. The responsive effect, it must be remembered, can be magnified to any extent that is desired by the Optic Lever, and in the present investigation a magnification of 200 times was employed. If the effect of the given electrode (laid on the upper surface), then, be to induce a responsive contraction, we can see that the normally horizontal leaf will be moved upwards, whereas a responsive expansion or relaxation would bring about a movement downwards. In order, however, to show the essential unity of all the different kinds of responses, whether by mechanical or growth movements, we shall regard them as cases respectively of the two fundamental phenomena of expansion and contraction. Expansion thus causes convexity or acceleration of growth, represented in these records by up curves, while contraction, concavity, or retardation of growth, is shown by down curves.

In my experiment on the upper half of the pulvinus of *Erythrina*, I first made it anode, the E.M.F. used being twenty volts. In previous experiments on the anodic and cathodic reactions of the pulvinus, it was the differential effect that was observed, and the magnification employed for the record was only slight. Hence the pure effect of anode-make was found to be inconspicuous, whereas the anode-break induced the usual marked contractile action. In the

present case, however, no complicating differential action being involved, and the magnification being considerable, we are able to detect a make-effect, which is contrary to the break-effect at anode—that is to say, it induces an expansion and consequent convexity. This anode-make expansion is quick, and soon reaches its maximum. At break the usual contractile effect is induced, but this is not here very clearly distinguishable from the movement of a natural recovery (fig. 230).

The current was now reversed, making the upper half of the pulvinus kathode. This induced a contraction and concavity which, unlike the quickly exhausted effect of the anode-make, went on increasing for some time. At kathode-break we see not only the cessation of the contractile effect, but probably also an expansion, aided by the natural process of recovery. Other experiments will be described presently, which will clearly show that not only do anode and kathode induce opposite effects, but that each at its own make and break exhibits reactions, which, though not of equal intensity, are of contrary signs. These interesting opposite effects, at make and break respectively, are not easily observed in muscle under ordinary conditions, inasmuch as muscle which is in the usual state of expansion cannot be further expanded; but Biedermann has found that smooth or cross-striated muscles, which are partially contracted, exhibit local expansion at the anode-make. Again, he found in the case of cardiac muscle that the kathode-break also gave rise to local expansion.

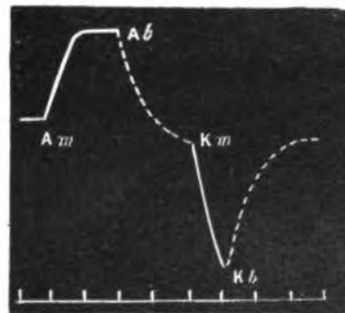

FIG. 230. Polar Effects of Currents due to Localised Application on Upper Half of Pulvinus of *Erythrina indica*

Up curve, in this and in fig. 232, represents expansion and convexity. Down curve represents contraction and concavity. Continuous curve represents the action at make. The dotted curve shows the effect at break. Am = convexity induced at anode-make. Ab = responsive concavity at anode-break. Km = induced concavity at kathode-make. Kb = expansion induced at kathode-break. The time-marks in this and following curves represent minutes.

These opposite effects at make and break, which I have already demonstrated in the case of the pulvinar response of vegetable tissue, will next be exhibited in a still more striking manner in the case of growth-response.

Anodic and cathodic effects on longitudinal growth.—

We thus pass from the question of the motile response of pulvinated organs to the polar effects of currents on the rate of growth. From a demonstration of the fundamental action here, we shall be able to infer the curvature which will be induced by the unilateral application of polar currents in the growing organ. Experiments on growth, especially when conducted by the Method of Balance, have the unique advantage that the opposite responsive effects, of expansion and contraction, are clearly distinguishable, and not liable, under any circumstances, to be confused with the natural process of recovery; for, as I have explained before, when a balanced horizontal record is taken of growth, an expansion or acceleration of the rate of growth will give rise to a deflection, represented, say, by an up curve. Recovery to the normal condition will now be indicated by a horizontal record. Contraction or retardation, similarly, will be represented by a deflection of the record downwards. Using this method, then, I have studied the effects of anode and cathode on the growing regions of both root and shoot, the second electrode being placed at a very great distance from the first, so that its effect may be considered non-existent. It may be said here that the results obtained were the same for both root and shoot, and I shall now describe the effects observed in the case of an experiment on the root of Bindweed, using an E.M.F. of twenty volts. One of the electrodes—a moist strip of cloth—is wrapped about the growing region; the second, as said before, being at a great distance. The balanced horizontal record of growth is first taken, and the growing region is made cathode. From the down curve in the record (fig. 231), it will be seen that a responsive retardation of growth is induced, which goes on increasing for a considerable time during the maintenance

of the current. The current was now interrupted, and as an effect of the kathode-break we obtain an expansion and acceleration of growth above the normal, as seen from the up curve. This acceleration persisted for nearly three minutes, after which the growth-rate became again normal. The current was now sent in a reversed direction, and the result of this anode-make was a sudden expansion and acceleration of growth, which, as in the case of motile response, persisted for a relatively short time, when the growth-rate, as seen from the return to the horizontal, became once more normal. The current was now interrupted, and as the result of anode-break we have a contraction and retardation of growth, which persisted for nearly a minute and a half, after which the growth-rate became again normal. From this experiment we again see that not only are the anodic and cathodic effects opposite, but that the effects on each of make and break are also opposite. It is also seen that the expansional effect caused by anode-make is relatively smaller, and occurs, and is completed, more rapidly than the kathode-make contraction, whose effect is more persistent. From these data we are able to arrive at a more comprehensive law of polar excitation in the case of vegetable tissues than was given in Chapter XVI., including not only ordinary mechanical responses, but also the modifications induced in growth. It will be understood that with regard to growth, expansion means acceleration of growth, and contraction means retardation.

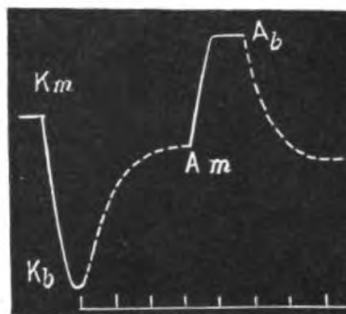

FIG. 231. Effects of Anode and Kathode on Variation of Rate of Growth in Root of Bindweed exhibited by Balanced Growth-record

Down curve represents contraction and retardation of growth, here and in fig. 233. Up curve represents expansion and acceleration of growth. Km = contraction at kathode-make; Kb = expansion at kathode-break; Am = expansion at anode-make, and Ab = contraction at anode-break. It will be noticed in this and other figures that the contraction at kathode-make is stronger and more persistent than the expansion at anode-make.

The generalised law of polar excitation in plants is as follows: **The kathode induces contraction at make, and expansion at break. The anode induces expansion at make, and contraction at break.**

Galvano-tropic response.—From the demonstration just made of the fundamental polar effects on growth, we can easily infer the responsive curvature that would be induced in a growing organ by the unilateral action of anode or kathode. I shall, however, show that the effects directly observed are in strict conformity with these deductions. For

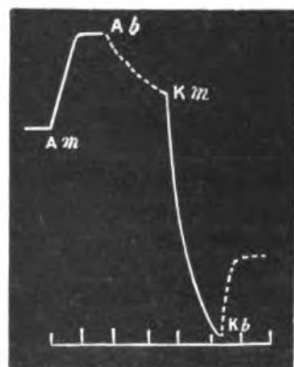

FIG. 232. Responsive Curvature in Scape of *Crinum* Lily by Unilateral Application of Anode and Kathode

Am = expansion at anode-make; Ab = contraction at anode-break; Km = contraction at kathode-make, and Kb = expansion at kathode-break.

these experiments I took the long scape of *Crinum* Lily, and on its growing region I applied one electrode, the other being connected with a distant point. On now making one side of the growing region anode, there was induced on that side a sudden and short-lived responsive expansion and convexity, seen in the up curve (fig. 232). At break, the opposite effect occurred, consisting partly of contraction and partly of natural recovery. The current was now reversed, and the effect of the unilateral kathode-make was the induction of a very active and relatively long-continued contraction and concavity, to be seen from the down curve. The kathode-break next gave rise to the opposite effect, which was made up partly of expansion, and partly of natural recovery. Thus in these galvano-tropic effects of currents on growing organs, we find what is simply a special case of the fundamental polar effects of currents on growth in general.

The indirect effect of polar excitation.—For the purpose of clearly demonstrating the fundamental action of currents, I have taken in the first place the simplest cases of the direct action of anode and kathode on the growing

responding region itself; but when similar applications are made, at a point distant from the responding region, we can foresee the fact that variations of these effects will occur. Thus the kathode-make, whose direct action induces contraction and concavity, will now, acting from a distance, bring about, by means of expelled water, the indirect effect of expansion and convexity. This can be demonstrated by selecting a growing and undetached petal of *Champaca*, in which the growing region is diffuse. The lower half of this petal is held in a clamp, the free upper half being attached to the Optic Lever for observation of its responsive movement. If now we make one side of the clamped half kathode (the other electrode being connected with the rest of the plant at a distance), then, at make of kathode, the indirect effect of stimulation, reaching the same side of the free end of the petal, gives rise to expansion and convexity—that is to say, the opposite effect to that which would have occurred had that region been directly subjected to cathodic action. The effect of the kathode on a distant growing organ is thus an acceleration of growth.

The effect on growth of 'electrification' of soil.—Empiric attempts have been made to discover whether the maintenance of an electrical current through the soil might or might not be made to have the effect of accelerating the growth of plants. This problem can only be satisfactorily solved, however, from accurate knowledge of the direct and indirect effects on growth of currents under the given conditions. Since growth is determined by the direction of current, it is not clear that currents flowing through the soil from right to left, or left to right, could give rise to a single effect. Looking, again, at the root, on which the current acts, we can see that one side will be anode and the other side kathode, and as the actions of these are known to be antagonistic, it is at first sight difficult to see how there can be any resultant excitatory effect at all.

We are, however, enabled to obtain a clear understanding of the subject by an attentive comparison of the responsive

effects of anode and kathode (figs. 230, 231). It is to be borne in mind that the growth of a plant, other factors remaining the same, is dependent on its suctional activity. And this again depends on the excitation of the root. Now, we saw that though the effects of anode and kathode at make are opposite, yet they are at the same time not equal. The anodic effect is relatively small and short-lived, and the cathodic effect is stronger and more persistent. Hence, though the effects on the two halves of the root may be electrically opposed, yet there will be a resultant differential effect of excitation, due to the predominance of cathodic action. Hence an electrical current, whatever be its direction, would excite the roots, causing a greater suctional activity, with consequent enhance-

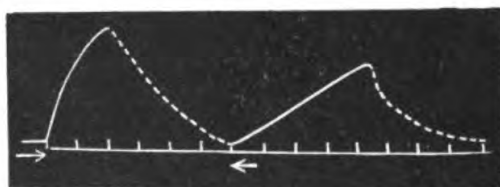

FIG. 233. Effect in Acceleration of Rate of Growth of Seedling of *Oryza sativa* of Current through the Soil

The continuous line shows effect during passage of current through the soil (1) from left to right (→), and (2) from right to left (←). Dotted line shows effect on cessation of current. Record of growth taken under balanced conditions.

ment of growth. This deduction I have been able to verify by experimenting on the variation of the rate of growth of seedlings of *Oryza sativa* when the soil in which they grow was subjected to a current, flowing now in one, and again in the opposite direction. The growth-record of a single seedling was first taken under balanced conditions (fig. 233). The electrical current was next sent through the soil from left to right, and during the continuation of this current, we see from the up curve the acceleration of growth above the normal that took place. The current was now stopped, and the former induced acceleration was replaced by a brief retardation, as seen in the down curve, after which the normal rate was restored. The current was next reversed, and yet the response was one of accelerated growth, and on the stoppage of the current after a brief retardation there was again a restoration of the normal rate. This experiment

ment of growth. This deduction I have been able to verify by experimenting on the variation of the rate of growth of seedlings of *Oryza sativa* when the soil in which they grow was subjected to a current, flowing now in one, and again in the opposite direction. The growth-record of a single seedling was first taken under

was carried out using an E.M.F. of ten volts, the two electrodes being applied at a distance of 10 cm. from each other. This meant a potential gradient of one volt per cm. This relatively strong voltage was applied for the sake of obtaining measurable response within a short time. But a much smaller E.M.F. is found to produce similar effects, though the action is slower. The application of a strong E.M.F. has the disadvantage of inducing fatigue, which is a drawback not present in the use of a feeble E.M.F. It is, however, shown that, during the continuation of a current through the soil, the rate of growth of a plant is enhanced.

SUMMARY

The effects of unilateral chemical and galvanic excitation may be studied, both from pulvinar and growth movements.

The unilateral application of alkali gives rise to positive curvature, that is to say, a movement towards the stimulating agent.

Acids, under similar circumstances, give rise to negative curvature.

The unilateral application of copper sulphate gives rise, by retardation of growth, to a concavity or positive responsive movement.

The unilateral action of dilute solution of sugar, by enhancing the rate of growth, induces negative response. A strong solution, however, gives the reversed or positive response.

Effects fundamentally similar are expressed by swimming organisms in appropriate movements to and from sources of chemical stimulation.

The assumption that the variation of curvature which occurs when an already curved organ is placed in strong solutions of salt is due to the action of plasmolysis is not always justified, for such solutions also exert characteristic excitatory effects.

The pulvinus of *Mimosa* in a favourable tonic condition

○ ○

reacts to the action of salt, at least for a time, by an erectile responsive movement. Under a less favourable tonic condition, it responds by depression. That this latter is not entirely due to plasmolytic action is seen from the fact that the leaflet subsequently becomes erected, as is the case under continuous stimulation.

The localised and unilateral action of anode and kathode on a pulvinated organ is as follows :

The anode-make causes expansion, inducing convexity. This effect attains its maximum in a short time.

The anode-break induces contraction and concavity.

The kathode-make induces contraction and concavity. This effect is stronger and more persistent than the opposite effect of expansion at anode-make.

The kathode-break induces expansion and convexity.

The polar effects on longitudinal growth are as follows :

The anode-make causes expansion and acceleration of growth. This effect attains its maximum in a short time.

The anode-break causes contraction and transient retardation of growth.

The kathode-make causes contraction and retardation of growth. This effect is stronger and more persistent than the opposite effect of acceleration at anode-make.

The kathode-break induces an expansion and transient acceleration of growth.

The localised and unilateral action of anode and kathode on a growing organ, results from the unilateral exhibition of those growth-variations which have just been described. Since a growing organ is virtually a diffuse pulvinoid, the effects are exactly similar to those seen in a pulvinated organ, already described.

Owing to the fact that cathodic action is relatively stronger than anodic, a feeble or moderate current flowing through the soil exerts an excitatory action on roots, by which the suctional activity of the plant is increased. The result is an increased rate of growth, which is independent of the direction of flow of the current through the soil.

PART VIII
HELIOTROPISM

002

CHAPTER XLI

FUNDAMENTAL RESPONSIVE ACTION OF PLANT-TISSUES TO STIMULUS OF LIGHT

Diversity of movements induced by light—Differentiation of responsive movements—Action of light on tissues in sub-tonic conditions—Effect of light on pulvinate organs—Effect of diffuse stimulation of light on non-growing radial organs—Retarding effect of light on longitudinal growth—Phenomenon of oscillation under long-continued stimulation—Similarity of responsive reaction under light and under other forms of stimulation.

THERE is perhaps no other phenomenon in the plant-world which is at once so striking and so universal as that of the response which is evoked from plants by the stimulus of light. Under this influence the plant as a whole, and every part of it, is tremulous. Not only does the growing stem curve towards or away from the incident rays, but every leaf under their action is thrown into a state of periodic daily rhythm. By the absorption of light, again, the plant is energised. Thus the two factors, of external stimulus and internal energy, whose manifestations are so opposite in character, are brought into play

Diversity of movements induced by light.—Light, as a form of external stimulus, evokes responsive movements, which appear to be extremely diverse in their nature. Radial organs, for example, such as stems, under certain conditions, direct themselves towards the light, and under others, again, away from it. Leaves, however, behave quite differently. These are said to possess the peculiarity of placing themselves with their surfaces at right angles to the light; but even this is not a property universally exhibited, for there are certain leaves which place themselves in a direction coinciding with

that of light, either towards or away from it. Some plants, again, close their leaves or leaflets on the approach of night, in the so-called 'position of sleep ;' while a further complication arises from the fact that an apparently similar 'sleep' movement is produced, in these or others, by the action of the noonday sun.

Light, again, appears in some cases to initiate movement, as was seen in *Desmodium* at standstill, and in others to arrest it, as is said to happen with the spontaneous movements of *Trifolium pratense*. Certain swarm-spores, moreover, appear to be attracted by light, swimming towards it, with energetic beats of their cilia ; while others, on the contrary, are affected in the opposite manner, and swim away. Or the same specimen may be found to swim, now towards, and again away from, light, swinging backwards and forwards like a pendulum.

We thus see that not a single responsive effect of light has been observed in the case of plant-organs of which an example directly to the contrary may not be found. For this reason it has appeared hopeless to attempt to unify these phenomena, and this fact has left investigators with little option but to tend towards a 'belief in the individuality of the plant in deciding what shall be the effect on it of external conditions.'¹

So far we have been considering only the diversity of the responsive effects which are induced by light in plants. When we come, however, to the further question of the responsive mechanics by which the stimulus of light evokes these movements, we are confronted at the outset of our inquiry by the fact that, as Pfeffer says, 'the precise character of the stimulatory action of light has yet to be determined.'²

Differentiation of responsive movements.—It is customary, in treating of plant physiology, to draw sharp lines of demarcation between the different classes of movements which are to be attributed to the action of light, ascribing each to

¹ Francis Darwin, *B.A. Report*.

² Pfeffer, *Physiology of Plants*, English translation, 1903, vol. ii. p. 101.

some unknown specific sensibility. Thus, Sachs differentiates some of the principal effects as follows :

‘In the case of that stimulation of light which produces waking and sleeping, the stimulus lies in the *variations* of the intensity of light ; it is not the light as a constant force which effects these movements, but the varying intensity. A further great difference between the heliotropic curvatures and those which bring about the sleep movements, lies in the fact that the organ can make heliotropic curvatures in all directions. The movement of waking and sleeping, on the contrary, only takes place in one plane, which divides the leaf and motile organ symmetrically, and it is thus unimportant here in what direction the rays of light fall upon the motile organ, but only important that light is present at all, or increases or decreases in intensity. The above will suffice for the distinction of the movement of waking and sleeping from the heliotropic curvatures.’¹

Finally, he summarises the differences of motile effects as follows :

‘We may thus say shortly, the movements of waking and sleeping are called forth by paratonic light stimulus, whereas the spontaneous movements of the same leaves are independent of any light stimuli, but probably dependent on phototonus. Heliotropic curvatures, on the contrary, have nothing to do with phototonus.’

It will be found, however, that all these effects, sharply differentiated as they are, may be seen in one and the same organ. We may take for example the terminal leaflet of *Desmodium gyrans*. This exhibits under favourable conditions autonomous movements, whose period is short. It exhibits also daily periodic movements, with the very long period of twenty-four hours. It further, as I shall show, exhibits positive heliotropic curvature when exposed to one-sided illumination. Of these effects, it is supposed that the autonomous movement is independent of the paratonic action of light, but probably dependent on phototonus. The daily

¹ Sachs, *Physiology of Plants*, English translation, p. 628.

periodic movement is held to be dependent on paratonic effects and phototonus. The heliotropic effect is ascribed to the continuous action of light, independent of phototonus.

Thus in the same organ we have to postulate various irritabilities and mechanisms, in order to account for its multifarious movements. Are there, then, independent or different irritabilities, coexisting simultaneously in the same organ? Such a state of things is so difficult to imagine, that it prompts us to try to look at the problem in a fresh light, divested of all assumptions which are incapable of experimental proof.

Approaching the matter thus directly, then, we see that, instead of so many different irritabilities, there may possibly be, fundamentally, but a single phenomenon of irritability, finding expressions apparently diverse, in consequence of the anatomical or physiological differentiations of the responding organ. If this should be so, the question will resolve itself into three separate inquiries. First, what is that responsive action which constitutes the characteristic effect of stimulus of light? Second, is such response to light unique in character, or is it a single instance of that universal phenomenon of contraction which we have seen to be the response of all excitable cells to stimulus in general? And, lastly, in what manner do the various anatomical and physiological differentiations of responding organs operate to modify the expression of this response?

Action of light on tissues in sub-tonic condition.—Before proceeding to a decisive demonstration of the nature of the effect of light on excitable tissues in a normal condition, however, I shall briefly refer to the suggestion which has been offered, that light in some unknown way induces a lessening of turgor, which brings about diminution of growth. This theory could not hitherto find acceptance for want of a precise knowledge of the exact nature of the stimulatory action of light, and of the relative significance of absorbed energy in promoting growth. Against the assumption that light diminished turgor, it was urged that the pileus of

Coprinus drooped in darkness, and became turgid on restoration to light; and the further supposition that light diminished growth was held to be negated by the instance of a dark-rigored plant, in which growth, so far from being retarded, was accelerated or renewed by simple exposure to light.

In both these instances we notice the abnormal condition induced in the plant. We must bear in mind that that rhythmic activity which is essential to growth depends, like all other rhythmic activities, not only on the turgor of the tissue, but also on the energy which it has absorbed. We have seen that when the sum total of independent stimulating factors present in the plant is adequate to raise its tonic condition above par, then rhythmic activity is initiated or renewed. Among these factors are, as has been shown: (*a*) a proper condition of turgidity; (*b*) favourable temperature; and (*c*) that previous absorption of energy of light which determines what we may distinguish as the phototonic condition.

The fact that, besides turgor, a certain amount of energy is also necessary to initiate growth has been fully demonstrated in a previous chapter. Taking now the case of the dark-rigored plant, we see that the arrest of its growth is due to a deficit of absorbed energy—in this instance, phototonus. Under these conditions, the renewed exposure to light would be sufficient, by supplying the missing factor, to re-initiate rhythmic activity and consequent growth. The drooping of the pileus of *Coprinus* in darkness is another expression of the sub-tonic condition of the plant. It must be remembered that the suctional activity which determines turgor is itself dependent on the rhythmic activity, and therefore on the tonic condition, of the plant. The critical element of this tonic condition may in certain cases be the absorption of light. I have noticed a similar drooping in flowering plants kept in the dark for a long time. Exposure to light, restoring the tonic condition, is in such cases, as also in *Coprinus*, sufficient to restore the normal turgidity of the plant.

In connection with this, I may draw attention to the fact

that the after-effect of absorbed stimulus in maintaining a favourable tonic condition is more prolonged in some cases than in others. In *Biophytum*, for example, the rhythmic activity by which the leaflets are thrown into pulsation is maintained only as long as the stimulating factors are acting. In *Desmodium*, on the other hand, there is a considerable capacity for storage of energy, and rhythmic activity persists for a long time, even on the removal of external stimulating agencies.

We thus see that the question of turgidity-variation alone is not sufficient to explain the action of light on a plant. We have also to take into account the important element of energy. We have briefly considered the effect of light on tissues in an abnormal condition; but our main inquiry concerns itself with the precise nature of the stimulatory effect of light on tissues which are in a normal tonic condition. I propose to demonstrate the character of this action by three independent lines of investigation. First, we shall study the action of light on pulvinated organs, in order to see whether or not this stimulus produces the same kind of differential contractile effect as other forms of stimulation. Secondly, discarding those complications which inevitably result from the differentiated structure of the pulvinated organ, I shall proceed to determine the precise nature of the fundamental form-change undergone by a tissue when excited by light. For this purpose I shall subject a radial organ to diffuse stimulation of light, observing whether or not under these circumstances it exhibits longitudinal contraction. And, lastly, I shall study the effect of light in inducing changes in the rate of growth, and shall also try to find out whether the fundamental responsive action discovered in the case of stationary, that is to say of non-growing, organs, might not be capable of explaining the observed variations of growth under the action of light.

Effect of light on pulvinated organs.—If a strong beam of light be applied to the pulvinus of the leaf of *Mimosa*

or to the pulvini of the leaflets of *Biophytum*, it is known that a responsive movement, similar to that evoked by any other form of stimulus, is induced. Now, we have seen that the response of such pulvini is given by means of differential longitudinal contraction. If, then, the effect of stimulus of light in this case is to produce a differential longitudinal contraction, we ought to be able to obtain from a radial organ, subjected to stimulus of light from all sides, a responsive longitudinal contraction.

Effect of diffuse stimulation of light on non-growing radial organs.—In order to demonstrate this, I took a radial style of *Datura*, and subjected it to the stimulus of light from all sides, by throwing a beam of sunlight which struck it on one side directly, and on others by reflection from properly inclined mirrors. On exposing the specimen to this stimulus for a period of four minutes, a responsive contraction of seven divisions was induced. On the cessation of light, there was recovery in the further course of a period of nine minutes. I next applied stimulus of light for six minutes, and a responsive contraction of eleven divisions was then induced, with a subsequent recovery on the stoppage of light, which was completed in fifteen minutes. We thus see that the effect of stimulus of light in producing responsive contraction is precisely the same as that which is the result of any other form of stimulation; that a feeble or short-lived stimulus induces a corresponding effect, from which recovery takes place, in a comparatively short time; and that a strong stimulus—unless it induce fatigue—will bring about a considerable contractile effect, from which the recovery is accomplished in a proportionately longer time. Again, I find that continuous stimulation of light produces a maximum tetanic effect, and that too long-continued action, bringing about fatigue, may induce fatigue-reversal—contraction passing into relaxation—as we found in the case of *Mimosa*, and of various radial organs which were subjected to too long continued action of stimulus.

Retarding effect of light on longitudinal growth.—We thus see that the fundamental contractile effect of stimulus is precisely the same in the case of light as in that of any other form of stimulation. We know also that the response of a growing organ is the same as that of one which is not growing. It has been shown further, that in a growing organ the contraction due to direct action of stimulus had the effect of retarding growth. Now, from the fact that the effect of light is the same as that of other forms of stimulation, it follows that the result of its direct action on a growing organ should be to produce contraction, and

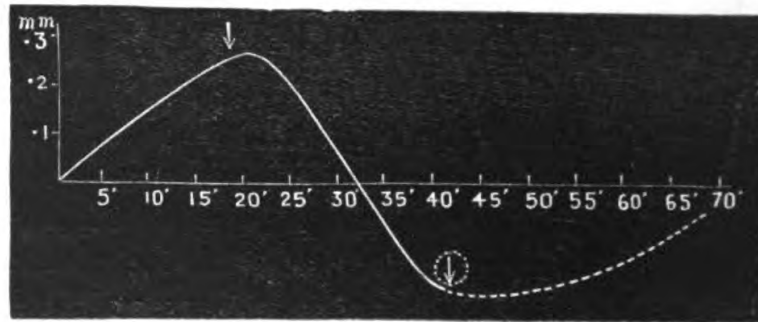

FIG. 234. Longitudinal Contraction and Retardation of Growth under Light in Hypocotyl of *Sinapis nigra*

The first part of the curve shows the normal rate of growth. Arrow (\downarrow) indicates moment of application of diffuse light, which is seen not only to retard growth, but also to induce a marked contraction. The second arrow indicates moment of withdrawal of light, and dotted portion of the curve shows recovery.

resultant retardation of growth. Though this conclusion, however, was thus clearly established in theory and by other experiments, using different forms of stimulus, I yet thought it important to test the matter with regard to the specific action of light, under conditions so simple as to bring out the fundamental phenomenon unmistakably.

In order to do this, I took a seedling of *Sinapis nigra* in which the hypocotyl was strictly radial, and made a record of its longitudinal growth (fig. 234). Its normal rate of growth, seen in the curve as movement upwards, was at the rate of .015 mm. per minute. On now applying light to the specimen on all sides at once, the growth is seen to

undergo rapid diminution till arrested, as seen by the curve becoming horizontal at its highest point. The continued application of light now proceeds to cause a marked contraction, the maximum rate of which is $\cdot 02$ mm. per minute. It is therefore to be noticed that, in this particular experiment, light not only retarded growth, but also produced an actual shortening of the plant. On the cessation of light, growth was slowly recommenced, but the average rate of growth during the sixteen minutes following the stoppage of light was only $\cdot 001$ mm. instead of the normal rate of $\cdot 015$ mm. per minute. This rate was, however, gradually increased in the absence of light, and after a certain interval became normal again.

It must be borne in mind, in connection with this, that though the immediate and after-effects of incident light are here seen as retardation of growth, nevertheless the rate, after the lapse of a certain interval from the cessation of stimulus, may be again increased above the normal in consequence of the enhancement of the tonic condition of the plant, by its absorption of energy of light.

In the last experiment we saw that responsive contraction not only arrested growth, but made the tissue actually shorter. In other instances the contraction and resulting retardation are not so great. Thus in a second experiment with *Sinapis*, the normal rate of growth was $\cdot 02$ mm. per minute, which during the continuance of light fell to one-tenth of this, or $\cdot 002$ mm. per minute. Thus the effect of light on the growing organ is always a contraction, which may in some cases induce a mere retardation, but in others culminates not even in cessation of growth, but in an actual shortening of the responding tissue.

The effects thus described occur in plants which are in normal tonic condition. But we have seen that when the specimen is, on the other hand, in a sub-tonic condition, absorption of energy in any form from outside will, at first, by increasing the internal energy, serve to accelerate growth; and that afterwards, when the normal tonic condition has been attained, external stimulus will have the normal effect

of retarding growth. In order to verify this inference I took a growing flower-bud of *Crinum* Lily, which had been previously kept in the dark. And for the further purpose of detecting even the transitory variations, I used the delicate method of balanced record.* On now subjecting the specimen to the stimulation of sunlight, acting on it from all sides, I observed a preliminary acceleration of growth, which lasted one

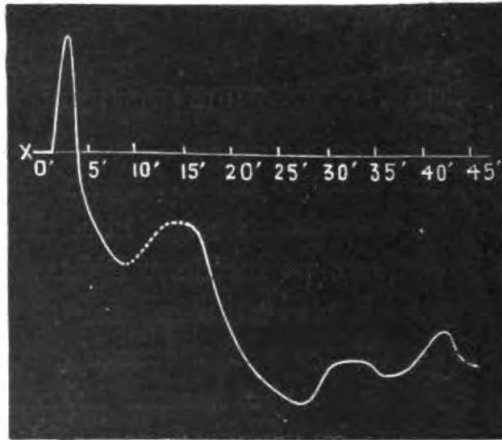

FIG. 235. Balanced Record of Variation of Growth in Flower-bud of *Crinum* Lily under Diffuse Stimulation of Light

Continuous lines represent the effect during application of light, the dotted line on withdrawal of light. The plant was originally in a sub-tonic condition, and application of light at \times , after short latent period, induces preliminary acceleration of growth. After this follows the normal retardation. On withdrawal of light, in the dotted portion of the curve is seen the negative after-effect, followed by return to the normal rate of growth. A second and long-continued application of light induces retardation, followed by oscillatory response.

tonic condition. Light was again applied, and retardation of growth is immediately shown by the descent of the curve. There is now no preliminary acceleration of growth, as in the case when the plant was sub-tonic. Under the long-continued action of light, there is now seen the very interesting phenomenon of the induction of autonomous pulsations of the rate of growth, whose period is about ten minutes.

minute (fig. 235). By this time the plant had evidently attained its normal tonic condition, and the continued action of light resulted in a retardation of growth, as seen in the rapid descent of the curve. The light was next shut off, and the after-effect of absorbed energy is seen in the consequent acceleration of the rate of growth above the normal. This acceleration lasted for four minutes, after which the plant returned to almost its normal growth, as seen by the record approximating to the horizontal. The plant may at this point be regarded as in ordinary

Phenomenon of oscillation under long-continued stimulation.—We have seen, in Chapter XXIV., that when a tissue is subjected to continuous stimulation, so that it becomes possessed of excess of energy, its response becomes pulsatory in consequence of periodic variations of its excitability. The exhibition of this variation of excitability we have, for the sake of convenience, designated as periodic fatigue. The occurrence of autonomous response is intimately connected with this periodic variation. In some tissues it may be exhibited only once, while in others it may be repeated indefinitely. For example, in *Mimosa*, under continuous stimulation, we see a single complete pulsation, consisting of the contractile response, and the subsequent fatigue-relaxation, which looks like recovery (fig. 59). But, in the longitudinal response of the style of *Uriclis* Lily to continuous stimulus, we observed two pulsations (fig. 58). And in *Biophytum* and *Desmodium* we see these repeated indefinitely, constituting what we know as multiple or autonomous response.

It is very interesting to note, in connection with this, that even inorganic substances, under continuous stimulation, exhibit this pulsatory response. I give here a record (fig. 236) of the oscillatory response of arsenic when acted on continuously by Hertzian radiation.

Or we may view this induction of multiple response in a radial vegetable organ, again, from a different standpoint. By the action of stimulus, it is easy to see that antagonistic hydrostatic actions may be set up as between the excited organ and the rest of the plant. Thus, the direct effect of continuous stimulation is contraction, with increasing expulsion of water from the excited organ into the rest of the plant. The hydrostatic reaction which this will induce in the

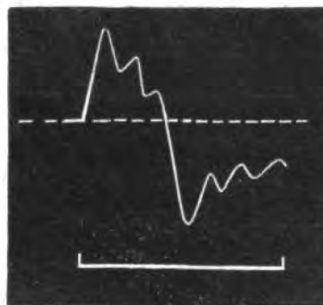

FIG. 236. Oscillatory Response of Arsenic acted on Continuously by Hertzian Radiation

Taken by method of conductivity variation.

rest of the plant will also constantly increase. The occurrence of oscillatory action, under these balanced and opposed forces, is what might be expected. Moreover, in the responding organ itself, we see the action of opposed forces to be induced ; for while the direct effect of local stimulus is to cause contraction, the absorbed stimulus is meanwhile increasing the internal energy, the result of which is the opposite expression in expansion. Thus, from what has been said, it would appear that in all these—namely, the hydrostatic action and reaction between the excited organ and the rest of the plant, the opposed effects of external stimulus and internal energy, and the presence of an excess of latent energy, with periodic variations of excitability—we have so many factors, which would all contribute to a common result, in the oscillatory character of the responsive expression.

But when we come to the case of anisotropic or dorso-ventral organs, we find an additional element making for alternation of effects, for when such an organ is diffusely stimulated, we obtain a differential response. But as the constitutions of the two anisotropic halves are different, the fatigue produced on opposite sides will not be simultaneous but alternate. Similar effects will also appear under unilateral stimulation of a radial organ. For here, too, the organ, owing to the relatively greater fatigue of one side, becomes molecularly anisotropic, and the stimulus by its long-continued action becomes internally diffused.

Similarity of responsive reaction under light and other forms of stimulation.—It has thus been fully demonstrated that the fundamental response of the plant to the stimulus of light takes place, like that to all other forms of stimulation, by contraction, leading, in the case of growing organs, to retardation of growth. Hence the unilateral stimulus of light may be expected to induce curvatures similar to those observed under other forms of stimulation, that is to say :

1. The direct effect of moderate unilateral stimulus of

light on the growing region will be a responsive concavity.

2. The effect of such stimulus of light, acting on the tip of either shoot or root, will be a convexity of the same side of the responding region.

3. Strong or long-continued stimulation of light acting on the growing region will induce a neutral or reversed effect.

4. The response, under certain conditions of continuous stimulation, may be characterised by pulsations.

It has been shown in previous chapters that the responsive action of anisotropic or dorsi-ventral organs is not fundamentally different from that of radial organs, the seeming differences being accounted for by differential action. In explaining the various effects of stimulus of light, then, the assumption of various sensibilities in the plant is unjustified.

I shall attempt, therefore, to trace out the manner in which one fundamental effect of responsive contraction is made to find diverse expressions, owing to the anatomico-physiological differentiation of the responding organ. And as the supposed different specific sensibilities do not exist, I shall designate all movements and curvatures induced by light as heliotropic, the signs positive, negative, and dia- being used only for descriptive purposes. An investigation into the action of stimulus of light, then, must apply itself to the following points :

1. The effect of unilateral stimulus, of varying intensity and duration, on the tips and growing regions respectively of radial organs.

2. The induction of autonomous movement by the absorption of energy of light.

3. The action of stimulus of light on molecularly anisotropic and on dorsi-ventral organs.

4. The direct and after-effects of light, in inducing movements of daily periodicity.

These are the questions which will be specially dealt with in the course of the following chapters.

P P

SUMMARY

The action of the diffused stimulus of light on a radial organ is, like that of other forms of stimulation, to induce a longitudinal contraction. The action on mature does not differ from that on growing organs. In a growing organ the induced contraction has the effect of retarding growth.

The response to light may thus consist not merely of a retardation of growth, but sometimes also of an actual shortening of the responding organ.

When an organ is in a sub-tonic condition, absorption of energy of light may give rise to a transient acceleration of the rate of growth; but when the plant has attained the normal tonic condition, response is by the usual retardation of growth.

The after-effect of stimulus of light may consist of a simple continuation of the characteristic responsive contraction or retardation of growth. This constitutes the positive after-effect. There may also be a negative after-effect, consisting of expansion or acceleration of the rate of growth.

Under the long-continued action of light, fatigue is induced. There is sometimes an exhibition of periodic fatigue with oscillatory response.

The response to light is not different from that evoked by any other form of stimulation. The various responsive movements which occur under the action of light are thus explicable without the assumption of the possession by different organs of different specific sensibilities to light.

CHAPTER XLII

POSITIVE HELIOTROPISM

Introduction—Theory of de Candolle—Inadequacy of de Candolle's theory—
Definition of terms positive and negative—Darwin's theory of modified circum-
nutations—Response of terminal leaflet of *Desmodium*—Extreme sensitiveness
of some plant-organs to light—Merging of multiple in continuous response—
Orientation induced by light—The perceptive region in the terminal leaflet of
Desmodium—Heliotropic response in radial organ—Magnetically controlled
recorder—Heliotropic response of hypocotyl of *Sinapis*—Recovery and theory
of recti-petality.

HAVING demonstrated the fact that the stimulus of light induces contraction in mature organs, and retardation of growth in growing organs, in precisely the same manner as any other form of stimulus, we shall now proceed to study in detail the various effects produced by the unilateral application of light. Such application, long continued, is seen to induce movement of the organ, in some cases towards the light, in others away from it, and in still other organs to induce a position at right angles to it. While it is doubtless convenient to distinguish such external effects as positive, negative, and dia-heliotropic, it is nevertheless unfortunate that these terms carry with them an assumption that the movements in question are due to as many distinct sensibilities on the part of the plant-organs. I shall, however, endeavour to show that there is in the plant but one fundamental sensibility to light, as to other forms of stimulation, which finds expression in contraction under its direct action; and that the resulting movements of the organs are dependent on the question as to whether stimulus acts directly or indirectly, unilaterally or diffusely, and also on anatomical or physiological peculiarities of structure. The complexity of the subject being very great, it has often

P P 2

been found difficult to resolve a given movement into its components, and this has led to the abandonment of the attempt to relate these various movements to any single basic reaction. So far was this carried that, in spite of the well-known observation that a radial organ, illuminated with different intensities on two different sides simultaneously, bends in the direction of the more intense illumination, Sachs found himself compelled to believe that it was the direction and not the intensity of light that determined the responsive movement.

Theory of de Candolle.—It is appropriate to make here a brief mention of the theory of de Candolle, which has hitherto met with unmerited neglect. De Candolle started from the known fact that light retards growth, and explained growth-curvature as due to the relatively greater growth of the shaded, inducing concavity of the lighted, side. This explanation of the mechanics of such movements constitutes an important advance, though it does not take full account of all the factors of the problem. This theory of de Candolle has, however, been discarded, in consequence of the difficulty which it presented of explaining the action of the negatively heliotropic organs, in which the lighted side is found to be convex. Extending this theory to cases of negative heliotropism, it was regarded as a logical inference that light should here accelerate growth. It is doubtful, however, whether such an inference is justifiable. In any case this was negated by the researches of Müller-Thurgau, F. Darwin, and Wiesner, who showed that light retarded general growth in negative as well as in positive heliotropic organs. It will be shown, however, in the course of succeeding chapters, that though the circumstances which modify the response of the plant, so that it is exhibited as negative heliotropism, are somewhat complicated, yet they in no way detract from the theory of de Candolle as applied to positive heliotropism.

Inadequacy of de Candolle's theory.—The flaw in his theory lies rather in the fact that he regarded the normal

rate of growth under shade as the active factor in growth-curvature, elongation on the lighted side being retarded, whereas in the case of positive light-curvatures the motive-power really lies in the active responsive contraction of the lighted side, the expelled water from which, reaching the opposite, may further cause an increase of growth above the normal. This fact, that it is the active contraction of the lighted, and not the passive growth of the unlighted, side that is actually the efficient cause of heliotropic curvature, will be made clear by taking an extreme case in which there is no growth. Here, if heliotropic curvature had been due simply to differential growth, the occurrence of curvature would have been an impossibility. But heliotropic curvatures are observed in organs which have come to growth-standstill. Again, grass haulms, in which growth is arrested, exhibit curvatures due to the contraction of the lighted, and the renewal of growth (due to the increased turgescence caused by expelled water) on the unlighted, side, in precisely the same manner as they were observed to do under the action of gravitational stimulus.

I shall now proceed to describe some typical experiments on heliotropic effects as induced by the unilateral application of light. And since it has been shown that the responses of growing organs are not essentially different from those of pulvinate organs, it will be helpful to begin by observing the effect of the unilateral application of light on the latter, especially as these have the advantage of showing relatively rapid reactions. In order to obtain a pulvinus which approximates in character to that of a radial organ, a specimen must be selected in which the difference of excitability, as between the upper and lower halves, is as small as possible. This may be found in the pulvinus of the large terminal leaflet of *Desmodium*.

Definition of terms 'positive' and 'negative.'—It will be demonstrated, in this and succeeding chapters, that however various in type may be the responsive movements induced by light, they are not due to the different specific

sensibilities of different organs, but can all be shown to form only special instances of a single fundamental effect. And this fundamental effect is the same in growing, in stationary, in radial, and in anisotropic organs. In describing the responsive actions induced by light, it will, however, be necessary to distinguish the direction of movement, in relation to the stimulating light, by clearly defined terms. I shall therefore designate all movements, of whatever organs, *towards* light as *positively heliotropic*, and all movements *away from* light of whatever organs, as *negatively heliotropic*.

Darwin's theory of modified circumnutation.—Before describing the response, it is necessary to say a few words regarding Darwin's view of heliotropic movements as a modified form of circumnutation. According to this, the already existing movement (of circumnutation) had only to be increased in some one direction, and lessened or stopped in others, in order to become heliotropic or ap-heliotropic, as the case might be ;¹ but, in order to prove conclusively that heliotropic curvatures were caused by the modification of the pre-existing movements, it would be necessary to show that they did not take place in those organs from which circumnutation was absent, and this would constitute the crucial test of the theory. The difficulty of obtaining such a specimen is, however, so great, that Darwin, although he noted the point, was unable to apply the test.

I have shown elsewhere that circumnutation is only a particular manifestation of that multiple or autonomous response of plants which is due to an excess of energy, previously absorbed. In order to obtain a plant-organ completely at standstill, therefore, it would be necessary to find a specimen in which there was no such excess of latent energy. The fact that circumnutation was absent could then be ascertained by means of the high magnification obtainable from the recording apparatus which I have already employed. Another difficulty lay in the fact that the use of light, however feeble, for purposes of observation, would be apt of itself

¹ Darwin, *The Movements of Plants*, p. 449.

to give sufficient stimulus to initiate multiple responses which had not been present before. This might have appeared incredible had I not, in the course of my experiments, had reason to know how extraordinarily sensitive plants may become to the influence of light, instances of which will be found in the investigations presently to be described. In view, indeed, of the vitiation of results which might be caused in this way, I was compelled to devise special means for obviating the use of any light whatsoever for the observation of responsive curvature.

Response of the terminal leaflet of *Desmodium*.—In order, then, to determine the important question of whether or not light will produce heliotropic movement in a plant devoid of circumnutation, I acted on the idea that the withdrawal of superfluous energy was the essential preliminary condition, and chose for my purpose, as already said, the large terminal leaflet of a specimen of *Desmodium gyrans* in which all movement had come to a stop—the plant having been exhausted by flowering, and by the unfavourableness of the season, which was winter. And further, in order that there should be no storage of energy derived from light, I kept this plant for one day in a dark room. To eliminate the necessity of using light for purposes of observation, I attached the leaflet by cocoon fibre to the arm of the Optic Lever Recorder. The plant itself was enclosed in a dark box, and thus protected from any access of light. Through a trap-door in the box, light for stimulation could be thrown down on the leaf at the desired moment. The preliminary absence of any autonomous movement in the plant was seen by the quiescence of the spot of light reflected from the mirror attached to the recording lever.

I now subjected the terminal leaflet of the selected specimen to light from a candle, this being thrown down on the leaflet vertically by means of a mirror, the effective distance of the candle from the leaf being twenty centimetres. The leaflet, which had previously been quiescent, began to respond after a latent period of ten seconds, and during the course of

an exposure of twenty minutes executed five complete oscillations (fig. 237). The notable points in this record are: (1) that a perfectly quiescent organ is made to give multiple response by the stimulus of light; (2) that molecular sluggishness appears to be gradually removed by the continuous absorption of energy, and the successive responses exhibit an enhanced or 'staircase' effect; and (3) that from the tendency of the series of curves to tilt towards the light, the organ is seen to exhibit a resultant positive movement.

It will thus be seen that we have here *not* a modification of an existing movement, but a series of multiple

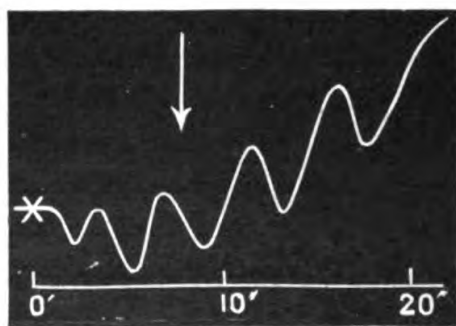

FIG. 237. Multiple Response to Light of Terminal Leaflet of *Desmodium*

The moment of application is marked by \times . The arrow shows the direction of light, i.e. from above. The numbers in the abscissa represent time in minutes.

responses, with a trend in a particular direction, that is to say towards the light, constituting a positive heliotropic movement. In a growing organ also, which was previously devoid of circumnutation, we shall be able to observe the induction of a similar movement. As in the case of the movements of growth, so also in those of heliotropism, we are often able to detect multiple constituent pulsations, especially at the commencement of response when stimulus is moderate. It will be understood here that, under the unilateral contraction induced in the excited side of the organ by the stimulus of light, a hydrostatic disturbance is set up, the expelled water being forced to the opposite side—a state of things calculated to show pulsation in a marked degree. The final resultant curvature, then, as we have seen under the action of other forms of unilateral stimulus also (p. 521), represents the joint effects of the concavity of the proximal and the convexity of the distal sides. When light acts on the organ continuously for some time, the

able to detect multiple

multiple responses become more frequent by the increased absorption of energy, and their individuality is lost.

The extreme sensitiveness of some plant-organs to light.—I shall now say a few words about the extraordinary sensitiveness of some plants to the stimulus of light. Darwin gives a striking example of this in a case where the cotyledons of *Phalaris canariensis*, after three hours of continuous exposure to a small lamp at a distance of twelve feet, became doubtfully curved towards the light, and after seven hours and forty minutes from the first exposure were plainly, though slightly, curved towards the lamp. The candle-power of the lamp is not given, but it may be taken to be about four candles. Reducing this to the standard distance of one metre, we find four candles at a distance of twelve feet (four metres approximately) to be equal to a quarter candle at a distance of one metre. If three hours' exposure induced a doubtful curvature, then the smallest amount of light to be effective must have been $\frac{3}{4}$ or .75 candle-hour; the candle-hour giving an indication of the quantity of light that had to be absorbed by the plant in order to induce a movement that was just perceptible.

Now, with the terminal leaflet of *Desmodium*, exposure to the light of a candle at a distance of 20 cm. for ten seconds was sufficient to initiate responsive movement. This when reduced to standard conditions is equivalent to .07 candle-hour. In other words, we find, as far as these two experiments can determine the point, that the terminal leaflet of *Desmodium* in this experiment was at least ten times more sensitive than Darwin's cotyledons of *Phalaris canariensis*.

Darwin, however, mentions another instance which is more like the sensitiveness of which I have just given an example. He has been using a small wax taper, in order to observe the cotyledons of *Phalaris*; he used this light for one or two minutes at each observation, and observed the seedlings seventeen times in the course of the day, in consequence of which he found that zigzag responsive movements had been induced.

I must again point out here that the specimen of

Desmodium which exhibited such remarkable sensitiveness had been specially chosen, as being in the least favourable tonic condition. And yet I could not even strike a match near this plant without inducing responsive movements. This will indicate the extreme sensitiveness of certain plants to light, and show that it is necessary to make our observations of induced movements without its aid. The manner in which this was done will be described presently.

Merging of multiple in continuous response.—We found that light acting from above on the terminal leaflet of

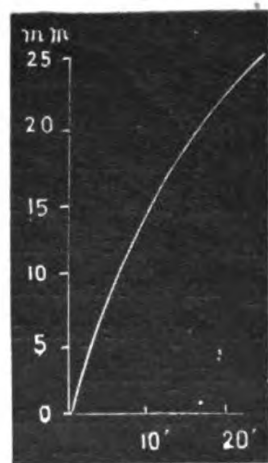

FIG. 238. Response of Terminal Leaflet of *Desmodium* to Strong Light from Above

Abscissa gives time in minutes, and ordinate movement in millimetres.

Desmodium gyrans gave rise to multiple responses. As the light was acting constantly on the upper half, there was a cumulative contractile effect on that half. The consequence of this was a trend of the series of curves towards the light, or an incipient positive heliotropic movement. I shall now proceed to show how these constituent multiple movements may often, if not always, merge into one continuous movement.

For this experiment I used the same leaflet as in the last, the only difference being that I now applied the strong stimulus of sunlight from above. The response induced is seen in fig. 238. During the first impact of the stimulus a pulsatory movement may sometimes be observed. But the response soon becomes a continuous movement upwards. Generally speaking, the constituent multiple marks are to be seen under feeble or moderate stimulation, and a continuous movement when the stimulus is strong. In the present case, the average rate of movement of the tip of the leaf was almost 1.5 mm. per minute (fig. 238). On the stoppage of light there was persistence for some time of the after-effect of light. This was succeeded by recovery. The persistence

of the after-effect varies widely, depending on the condition of the tissue as well as the intensity of stimulus.

Orientation induced by light.—When the leaflet, with its sensitive motile organ, is exposed to strong sunlight, the heliotropic movement continues till the organ becomes parallel to the direction of light. The question now arises, in this as in other cases of heliotropic movement, why should the movement come to a stop when the organ reaches this parallel position?

A partial answer to this question may be found in the fact that such movements depend upon the effective intensity of light which is absorbed, and this effective intensity is greatest at perpendicular incidence, and becomes reduced to nearly zero as the rays of light are rendered more and more oblique by the responsive movement of the organ. This consideration alone, however, would not wholly explain the orientation of the organ, parallel to the direction of light, for we know that the directive impulse caused by light persists for some time, and this would cause the organ to overshoot the parallel position. In order, therefore, to obtain a satisfactory explanation, I undertook the following experiment, which, as will be seen, completely meets the difficulties of the case.

I now took the same leaflet of *Desmodium* as was used in the previous experiments, and caused sunlight to strike the pulvinus vertically, from below upwards, by means of a suitably inclined mirror. I obtained, as will be seen (fig. 239), a continuous responsive movement downwards—i.e. towards the direction of the light. The average rate of movement of the tip of the leaf was in this case about 2.5 mm. per minute. This is somewhat greater than the upward rate of movement,

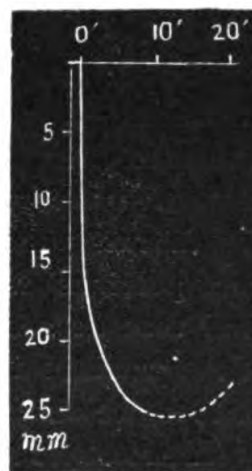

FIG. 239. Response of Terminal Leaflet of *Desmodium* to Sunlight acting from Below

The dotted portion of the curve represents the after-effect and recovery on the cessation of light.

and is probably due to the fact that the excitability of the lower half of the pulvinus is slightly greater than that of the upper.

We are now in a position to understand the reason of orientation; for if we suppose light to be incident from a position slightly above the pulvinus, it will curve upwards, owing to positive heliotropism, till it has become parallel with the rays of light. Should there be any over-shooting of this position owing to after-effect, the pulvinus will then begin to curve downwards, because the light will now be acting from below. Permanent equilibrium can thus only be attained when the plant-organ has become parallel to the direction of light.

The perceptive region in the terminal leaflet of *Desmodium*.—In connection with the response of the *Desmodium* leaflet to light, it is interesting to note that the pulvinus is not only the responding, but also the perceptive region; for, throwing the light on the leaflet alone, and protecting the pulvinus with an opaque shield of black paper, we find that no responsive movement takes place; conversely, if the pulvinus alone be exposed, and the rest of the leaflet shaded, we observe the normal action.

Heliotropic response in radial organs.—Having observed the peculiarities of heliotropic movement in a pulvinated organ, I shall now describe the experimental arrangements for studying the same problem, in non-pulvinated growing organs. It is understood that there is no essential difference between the two movements. They are both caused by the same contractile effect, due to the stimulus of light, the only difference being that, whereas in the pulvinated organ the recovery is complete, in the growing organ it remains more or less incomplete, the curvature being fixed by growth.

Magnetically controlled recorder.—The great difficulty which stands in the way of accurate investigation is the question of how to take a *continuous* time-record of the heliotropic curvature of the growing organ without being under the necessity of using light for purposes of observation,

a procedure which, as we have seen, causes disturbance. The free end of a normally growing organ, when acted on, say by horizontal light, bends towards it. Thus the problem is to obtain a continuous time-record of this movement, from which the latent period, the actual rate of movement, the after-effect, and other related effects might be ascertained. I have been able to solve this difficulty by devising a mag-

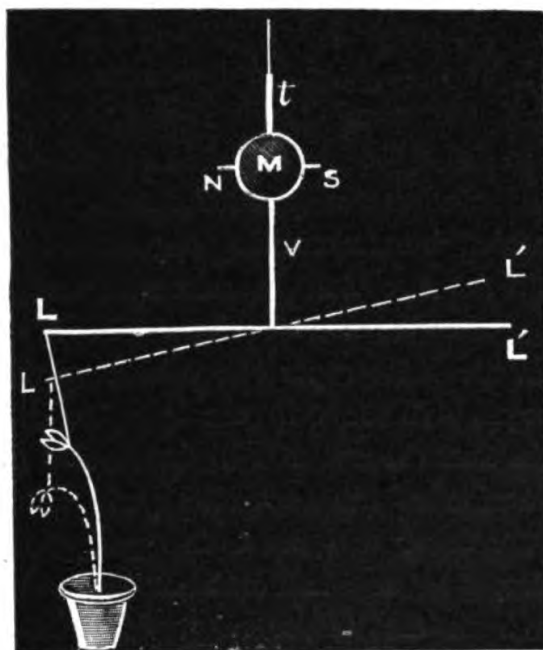

FIG. 240. Diagrammatic Representation of the Magnetically Controlled Recorder

LL' , the Optic Lever, to one arm of which the plant is attached by a thread; M , the mirror, with small magnet, NS , attached behind. The lever is rotated to dotted position by heliotropic curvature of the plant, diagrammatically represented disproportionately magnified.

netically controlled recorder, the principle of which will be understood from the accompanying diagram (fig. 240).

The principal part of this recording instrument consists of a magneto-metric arrangement. Attached to a long aluminium lever, LL' , is a vertical T-piece, v . This T-piece, v , carries a reflecting mirror, behind which is a short magnet, NS . The whole arrangement is freely suspended by a silk thread. By means of a controlling magnet not shown in the

figure, the suspended lever may be adjusted in any convenient azimuth.

The free end of the growing plant is attached to one end of the lever, L, being on its own level, at a distance of, say, 20 cm. from the line of suspension, the attached thread being at right angles to the lever. There is a slight tension of the thread, due to the magnetic force of the controlling magnet, which tends to draw the lever away from the plant. This tension, however, is very slight. When the growing organ is acted on by light in a horizontal direction, parallel to the attached thread, and therefore at right angles to the lever, then if the action of light be to induce a positive heliotropic effect, the rotation of the suspended magnetic system, owing to the pull exerted by the curving organ, will be, when seen from the top, in the direction opposite to that of the hands of a watch.

If, however, the heliotropic effect be negative, the top of the growing organ will move in the opposite direction. But it has been said that there was a slight tension of the thread, owing to the action of the controlling magnet. This being now released, the lever will move to a proportionate extent in the same direction as the hands of a watch. A spot of light reflected from the mirror magnifies these movements, and a record of this moving spot of light on a revolving drum gives the response-curve. Instead of this magnetic control, it would also be possible to use, as the controlling force, the torsion of a fine metallic wire.

By using a shorter lever arm and increasing the distance of the revolving recording drum from the mirror, a wide range of magnification up to 500 times may easily be obtained. For ordinary purposes a magnification of ten times is all that is necessary.

The movement of the spot of light is proportionate to the heliotropic movement of the plant, at least when the amount of that movement is not excessive. Thus, knowing the magnification produced by the system, and the rate of the revolving drum, we can determine from the

response-curves the absolute movement, and the rate of such movement.

I now give a description of the complete apparatus actually used (fig. 241), consisting of the Recorder and the Heliotropic Chamber. In a dark chamber is placed the plant, attached to the Lever as explained before. A portion of the vertical piece with attached mirror, M, projects outside the chamber. It will be seen that by this arrangement the

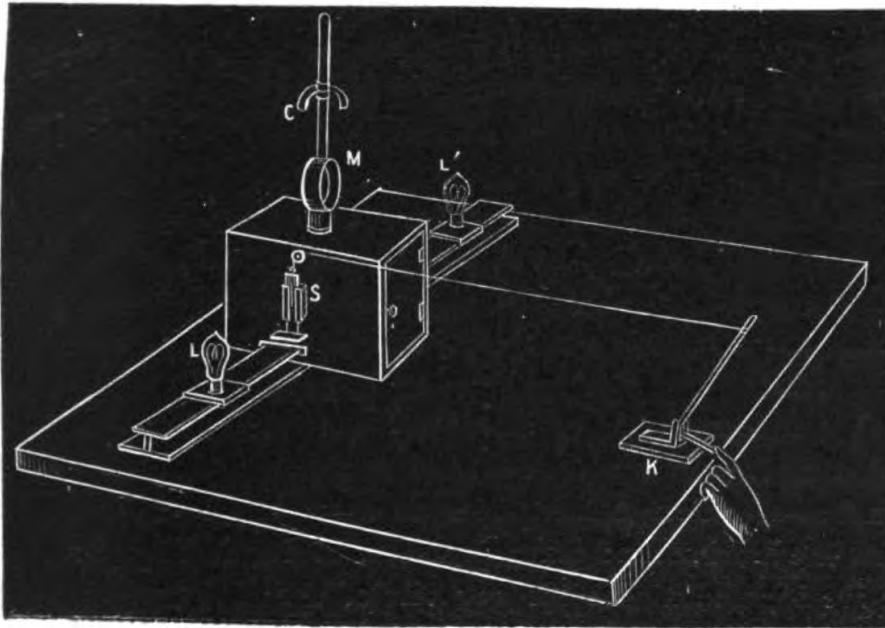

FIG. 241. Heliotropic Chamber and Magnetically Controlled Recorder

Heliotropic chamber seen in the middle of the apparatus. Guide-bars to right and left carry sliding lamps, L and L'. Exposure is given by pressing key, K, which raises shutter, S. The corresponding shutter to the right is not shown in the figure. M, mirror of the Optic Lever; C, controlling magnet.

plant can be completely protected from light, while its movements are at the same time recorded by the spot of light thrown from the mirror, M, upon the recording drum, without the possibility of its reaching the plant within the chamber.

The chamber carries two projecting graduated arms or guide-bars, one to the right and the other to the left, over which slides the holder for a candle, or incandescent, or Nernst's electric lamp, LL' ; but if a still stronger light be

desired, sunlight may be reflected in the required direction by a mirror. From whatever source, the light can be made to strike the plant horizontally through the slit, which is usually covered with a sliding shutter, *s*. By manipulating a key, *k*, the shutter is raised. Thus exposure may be made at any moment, and continued for the length of time desired.

That part of the record which is made on the revolving drum before exposure begins, gives an indication of the quiescent condition of the plant. The moment and duration of exposure are found from corresponding marks made on the recording surface, at the instants of opening and closing the shutter.

It will be seen that we have means of controlling the intensity of illumination within wide limits by (1) the use of different sources of light as enumerated above, and (2) variation of the distance of the source of light, at least when this is artificial.

Thus we are able to illuminate the plant from the right or left flanks, or from both simultaneously, and by lights of equal or of different intensities, at will. Again, by covering the slit with a second plate, provided with suitable apertures, we are enabled to subject any part of the plant, whether tip or growing region, or both, as desired, to the stimulus of light, and thus to determine the characteristic response of each. All these considerations will show the facilities afforded by this apparatus for carrying out a great number of diverse experiments. I shall, however, content myself here with the description of a few necessary examples.

Heliotropic response of hypocotyl of *Sinapis*.—As examples of radial organs, exhibiting the positive heliotropic effect, I took seedlings of *Sinapis nigra*. They were attached to the lever, as indicated above, and at least half an hour was permitted to elapse, in order to remove the last possible trace of excitation due to contact. The attainment of the quiescent condition was ascertained from the stationary position of the spot of light.

In this experiment, on a seedling of *Sinapis*, light was allowed to strike the growing organ horizontally. The specimen was very sensitive, and the source of light employed at first was a candle placed at a distance of 20 cm. acting on the plant for three minutes. The responsive movement began within five seconds, and though the light was cut off, there were produced three multiple responses, after which the plant underwent a complete recovery and resumed its former position. Sunlight was next applied, and a continuous movement towards the light was induced (fig. 242).

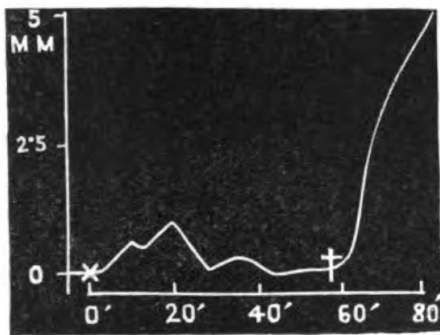

FIG. 242. Heliotropic Response of *Sinapis*

× Application of candle-light for three minutes gave three multiple responses; † application of sunlight gave rise to continuous response.

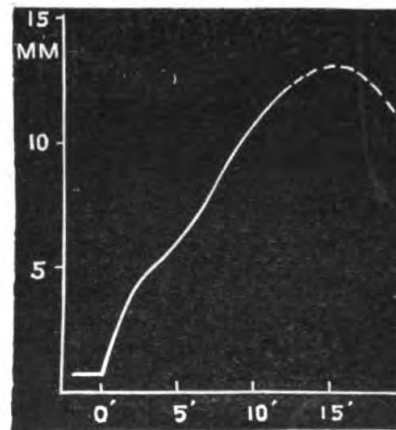

FIG. 243. Heliotropic Response of *Sinapis* to Sunlight

Dotted line shows after-effect and recovery on cessation of light.

In another case sunlight was applied for twelve minutes. The response commenced almost immediately on application, and the average rate of movement was 1 mm. per minute. In this particular case, the positive after-effect persisted for five minutes, even on the stoppage of light, after which there was a gradual recovery (fig. 243).

Recovery and theory of recti-petality.—On the cessation of stimulus, there is a more or less perfect recovery of the radial organ from its induced curvature. I have already demonstrated the fact that the growing organ acts as a diffused pulvinoid. We have just seen that the primary action of light is to induce similar motile effects in both

Q Q

pulvinated and growing organs. We have also seen that in both, on the cessation of stimulus, there is a tendency towards recovery. In the case of the growing organ, when stimulus is moderate, recovery is fairly complete ; but when the stimulus is very strong and long-continued, some part of the induced curvature is rendered permanent through fixation by growth.

An attempt has been made in the case of Vochting's Theory of Recti-petality to account for this recovery, by assuming the action of an unknown regulating power which would tend always to bring the organ back to a straight line ; but, beyond the assumption of an unknown specific power, this theory affords no explanation of the mechanism by which recovery is brought about, and I am able to adduce considerations which obviate the necessity for thus assuming the existence of any such specific agency as that of recti-petality.

In a growing organ which is radial, the tip of the growing region being free, the vertical direction is that in which there is least obstruction to growth, and as long as all the lateral tensions are the same in all directions, there is no reason why the organ in the course of its upward growth should bend permanently on any one side more than on another. We have therefore the normal growth of radial organs in a straight line ; but when stimulus acts unilaterally on the growing region, a sequence of events ensues, which has already been fully explained :

(1) Active contraction is induced during the continuance of stimulus, on the proximal or excited side, with concomitant diminished turgidity, and retardation of growth.

(2) The water thus expelled is forced, against tension, into the growing cells of the distal side, raising their turgescence and consequent rate of growth above par.

(3) The curvature thus induced is maintained as long as the difference of hydrostatic pressure on the two sides is continued, by the persistent contraction of the proximal, under the action of stimulus.

(4) When the stimulus ceases to act, the active contraction which forced the water against tension to the distal side comes to an end, and there is a rebound of the expelled water to the proximal side. Thus the increased growth of the distal falls, and the decreased growth of the proximal rises, to the normal rate of growth. The unequal tensions on the two sides, which previously maintained the curvature, being now equalised, the organ shows a tendency to straighten itself.

(5) I have also shown that a tissue which has been subjected to stimulus, having absorbed energy and held it latent, exhibits it on the cessation of external stimulus, in the form of a temporary negative after-effect, that is to say an acceleration of growth above the normal. As a result of this fact, the stimulated side of the organ will show an *active* tendency to neutralise the previous curvature, and return to the straight line.

It is thus seen, from facts which I had already established regarding the nature of the after-effect of stimulus, that the recovery of the organ is fully explained, without postulating the existence of any specific power, such as that of rectipetality.

SUMMARY

The responsive movement of the plant-organ towards light is due to the excitatory contraction of the side acted upon. The curvature of a growing organ towards light is brought about by the joint action of the induced concavity of the proximal and the convexity of the distal sides. The former is the result of the contraction, negative turgidity-variation, and retardation of growth caused by the stimulus. The latter comes about by the positive turgidity-variation due to forcing-in of expelled water, expansion and acceleration of growth of the distal side.

Such responsive movements take place in organs previously devoid of circumnutation.

The sensitiveness of certain plant-organs to heliotropic stimulus is very great. The terminal leaflet of *Desmodium*

Q Q 2

responds under the briefest exposure to feeble candle-light. This necessitates the making of observations on heliotropic effects without the aid of light.

The perceptive region for the stimulus of light in the case of the terminal leaflet of *Desmodium* is the pulvinus.

There is no essential difference between the heliotropic response of a growing and a pulvinated organ.

On the cessation of stimulus the recovery of a pulvinated organ is complete ; and this is more or less true also of the recovery of a growing organ from response, if the stimulus have not been excessive.

For the explanation of this recovery in a growing organ, it is not necessary to assume the existence of any specific power such as recti-petality. The cessation of the difference of hydrostatic pressure on the two sides—such difference being only maintained during the action of stimulus—together with the accelerated rate of growth on the proximal side, which constitutes the negative after-effect, are quite sufficient to explain the recovery from induced curvature.

CHAPTER XLIII

NEGATIVE HELIOTROPISM

Incomplete parallelism between actions of light and of gravitation—Theoretical considerations — Recording microscope — Negative heliotropic curvature induced by stimulation of the tips of root and shoot—Intermediate phases between positive and negative heliotropic response: (*a*) neutralisation by transverse transmission; (*b*) neutralisation by transverse transmission, with multiple response—Localised sensitiveness to light and transmission of excitatory effect—Negative heliotropism of a radial organ—Gradual transition from positive to negative, through intermediate phase of neutrality—Apparent heliotropic insensitiveness of certain tendrils—Negative heliotropism of tendril of *Vitis*.

WE have seen in the chapter on the response due to gravitation, that the responsive curvature of the root is opposite in character to that of the stem, this fact having led to the assumption of specific sensibilities as characteristic of the root-tip. It was there shown, however, that the responsive characteristics of the root were not actually different from those of the shoot, and that the differences in their observed responses were simply a consequence of the fact that in the one case the stimulus of gravity acted indirectly, and in the other directly, upon the responding growing organ. This assumption that the root possessed a definite sensitiveness characteristically different from that of the stem, was apparently supported by certain differences in heliotropic action also, as between shoot and root; for example, while the hypocotyl of *Sinapis* bends towards the light, the root is found to bend away from it.

Incomplete analogy between action of light and gravitation.—But I have already explained the fact that the supposed analogy is false; for while the stimulus of gravity acts, in the case of the root, only on a restricted area of

the tip, the stimulus of light is not necessarily restricted in the area of its action. Again, whereas the stimulation caused by statolithic particles is moderate, that caused by light may be of any degree of intensity. The fact that there is no true extended analogy between the action of light and that of gravitation, is seen from the fact that, while gravitation in the case of the root induces a movement opposite to that induced in the stem, in the case of light this is not always so ; for though a few roots turn away from light, in others there is either no resultant movement, or movement towards the light. Again, while the shoot makes a definite curvature with reference to the direction of gravity, in the case of light we shall observe that though under moderate stimulation it turns towards it, yet it will sometimes under stronger stimulation be found to move away. The idea that positive and negative heliotropic curvatures are due to two distinct sensibilities could not be better disproved than by the fact, which will be demonstrated shortly, that the same organ can be made under different conditions of illumination to exhibit the two opposite effects.

Discarding, then, the theory of any specific sensibility, we shall now proceed to show how the movement away from the stimulating light, the so-called negative heliotropic curvature, is brought about.

Theoretical considerations.—From the movements already demonstrated (p. 535) as taking place in plant-organs in response to stimulus unilaterally applied, we can see the possibility of such movement becoming negative, or away from stimulus, under three different conditions :

(1) Under longitudinal transmission of the indirect effect of stimulus, when, for example, moderate stimulus is applied to the tip of either shoot or root.

(2) Under transverse conduction of the direct excitatory effect of stimulus to the distal side of a radial organ, the proximal side being fatigued by excessive stimulation ; and

(3) Under the transverse transmission of excitation to the distal side of an anisotropic organ, the distal side being the

more excitable. In this last case, we may obtain a very pronounced negative response in consequence of the relatively greater natural excitability of the distal side.

We shall see in the course of this and the following chapters how heliotropic movements other than positive are actually brought about under these different conditions, and in the present chapter we shall study cases which are illustrative of the first two.

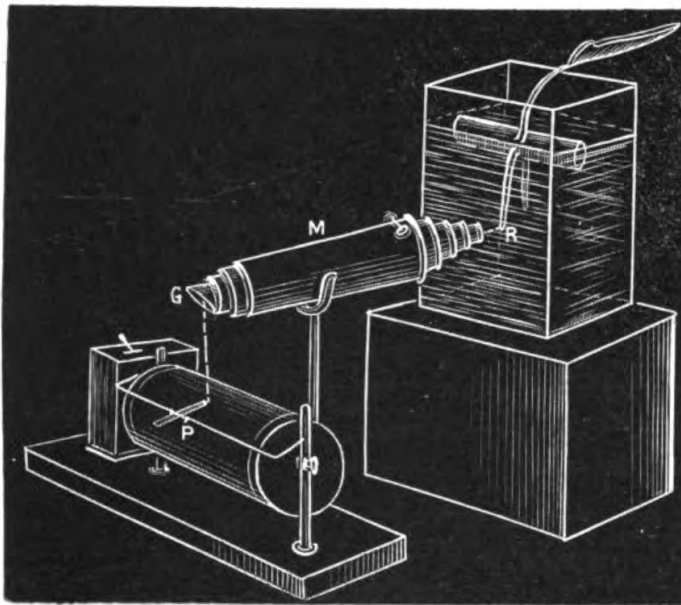

FIG. 244. Microscope Recorder

Plant mounted in cubical glass trough with root in water. Light strikes root, R, unilaterally from the right side. Movement of root observed by microscope, M, the inclined transparent disc of glass, G, giving at the same time the reflected image of the recording pen, P.

Recording microscope.—Since the growing root has to be kept in water, for the purpose of studying the phases of its responsive curvature, the method hitherto employed of obtaining records by the Optic Lever is inapplicable. I therefore devised a different method of observation—that of the Recording Microscope (fig. 244). The method of record will be understood from the figure, where in a cubical glass trough a piece of the stem of Bindweed, with its water root, R, is securely fixed on the surface of the water. Light is made to

strike the root unilaterally, say from the right side. This pencil of light may be so thrown as to act locally on the root-tip, or on the growing region, or on both at the same time. The movement of the root towards or away from light is observed through the microscope focussed on the tip. The eye-piece end of the microscope has a disc of glass adjusted at an angle of 45° to the vertical. The observer sees the tip of the root directly through the transparent disc, and at the same time the reflected image of the recording point of the pen, lying against the revolving drum below. The two images are at the beginning of the experiment coincident, and the responsive movement of the tip of the root, which takes place afterwards, is easily followed by the observer with the recording pen. Thus we obtain the response-record on the moving surface. This method of the recording microscope can always be used when attachment to the Optic Lever is not possible or not desired.

Negative heliotropic curvature induced by stimulation of the tips of root and shoot.—I have by this method obtained various records of the responses of the root and shoot to the unilateral stimulus of light applied at the tip. Of these I shall give, as a typical example, the record of the root of a seedling of *Sinapis nigra*, suitably mounted in the cubical trough by means of a cork. The curve seen to the left of fig. 245 represents the negative movement, or movement away from light, of this root, when the tip alone was unilaterally stimulated. This movement was due therefore to the indirect action of the stimulus on the growing responding region. After a period of rest in darkness I next took a record of its movement resulting from the direct unilateral illumination of the growing region. I now obtained a positive responsive curvature, as seen to the right of fig. 245. It will be noticed that this particular movement was relatively smaller than the preceding. We must here remember that the receptivity of an organ is not the same in all its different parts, and the greater negative response induced in this case by the indirect action of stimulus on the

tip is probably due to the higher degree of receptivity possessed by that part of the organ. In taking a third record in a case in which both tip and growing region were simultaneously subjected to unilateral stimulation of light, I found that a resultant responsive movement was induced, which was away from light.

That this negative movement, induced by stimulation of the root-tip, is not due to any specific sensitiveness of the root as such, is seen from the fact that on local stimulation of the tip of the shoot, *e.g.* the flower-bud of *Crocus*, I obtained a responsive movement away from, whereas unilateral stimulation of the growing region of the peduncle induced a movement towards, light.

Apart from this possible factor, however, of the greater receptivity of the tip, there is another, which tends to make the positive curvature of the growing region of the root relatively ineffective. This region, being acted on unilaterally by

light, the proximal excitation often passes by conduction to the distal side, thus neutralising the first positive action. Instances of this will be given in greater detail presently.

The negative curvature induced by the action of the tip, depending as it does on the indirect transmission of stimulation, requires as a condition the relative non-conductivity of the intervening tissue to the passage of true excitation. Hence, if the conductivity of such a tissue be not sufficiently feeble, or if the intensity of stimulus be too great, we shall find that the direct effect of stimulus is transmitted to the growing organ, and a positive curvature is induced. This

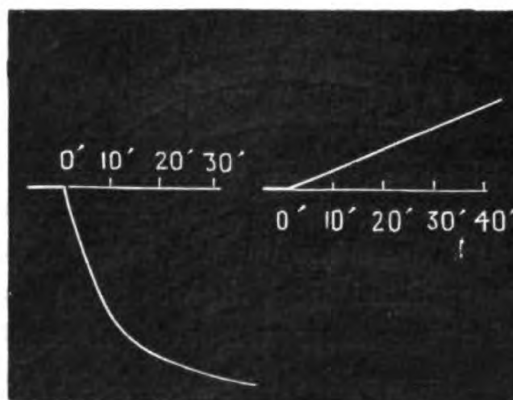

FIG. 245. Record of Response of Root of *Sinapis nigra*

The curve seen to the left shows the negative response due to stimulation of root-tip. The curve to the right exhibits positive response on stimulation of growing region.

explains the positive heliotropic curvature exhibited by many roots.

Intermediate phases between positive and negative heliotropic response.—I shall next proceed to demonstrate the induction of negative heliotropic movements in radial shoots, a phenomenon which, for reasons already explained, has no parallel in the case of geotropic action (p. 544). As it has already been said that there is no specific sensibility which determines the positive or negative character of the heliotropic response, it would be interesting to trace out the transitions by which the normal positive is gradually transformed into the negative movement. We have seen that when stimulus is applied unilaterally to a growing region, the positive curvature at first induced is jointly due to the contraction caused by direct stimulation of the proximal and the expansion caused by the indirect stimulation of the distal; but when the stimulus is strong or long-continued, excitation is transmitted from the proximal to the distal, the contraction of which latter now neutralises the first effect. Hence the normal positive curvature disappears.

(a) *Neutralisation by transverse transmission.*—The considerations just related explain the curious anomaly that has been observed, by which, while feeble or moderate stimulus of light, or interrupted light, gives rise to well-marked positive heliotropic curvature, the continuous application of stronger light induces a relatively feeble effect. Thus under moderate lighting we often observe strong heliotropic curvature, which disappears under strong sunlight. The curvature induced is, as we have seen, due to the *differential* action of unilateral stimulus, on the proximal and distal sides; but when a strong light is used the stimulus becomes internally diffused, and the differential effect on the two sides is reduced in amount or vanishes altogether. Such internal diffusion is due to the fact that, owing to the weak transverse conductivity of the tissue, while a feeble stimulus is not conducted across it, a stronger stimulus is. This consideration, together with the fact that the conductivity of a tissue undergoes seasonal variation,

will be found to offer a satisfactory explanation of various anomalies in heliotropic response. *Sinapis*, for example, exhibits a strong positive effect in winter, while in hot weather its action is very feeble. It may be supposed that this is due, in some unknown way, to a greater rapidity of growth in warm than in cold seasons. That this, however, cannot be the reason, will be seen from the fact which I have demonstrated, that that contractile response of the plant to external stimulus on which curvature depends is greatest when the rate of growth is at its optimum. The real explanation lies in the fact that the neutralisation, or reversal of normal positive response, caused by transverse conduction, takes place more easily in warmer seasons, the general conducting power being then great. This accounts for the feebler positive response in summer, which culminates in certain instances in an actual reversal into negative (p. 623).

(b) *Neutralisation by transverse transmission, with multiple response.*—Thus if stimulus be sufficiently strong or long-continued, the positive curvature will become neutralised, and the organ will return to its original position. I have, however, observed an interesting modification of this neutralisation, in which it is attended by oscillatory movements to and fro about the mean position. We have seen that unilateral stimulus, when its action is long continued, becomes diffused, and thus both sides of the organ become excited. The tissue, moreover, is now possessed of an excess of energy—a condition conducive to the production of multiple response. This fact, together with the periodic and alternate variation of excitability on the two sides, is then found to give rise to oscillatory movements of the kind described. I give below a record which shows the initiation of these oscillatory movements when the organ had been too long subjected to unilateral stimulus. It will be remembered that the pulvinus of the terminal leaflet of *Desmodium* executes a positive heliotropic movement, the record of which has been given in fig. 238. In winter, when the conductivity of the tissue is feeble, the leaflet curves towards

the light to the maximum extent possible, and remains in that position as long as the light acts. But we have seen that in summer the stimulus is more likely to be internally transmitted to the distal side, the positive effect being thus gradually neutralised. Thus, in the course of an experiment during the summer on the pulvinus of the terminal leaflet of *Desmodium*, I found, on subjecting it to sunlight from above, that for the first forty minutes the leaflet rose continuously, its tip having moved during that time through a little more than 4 cm. After this there was induced, instead of the continuous movement upwards, a pulsatory movement up and down (fig. 246). After a series of such movements the leaflet was gradually depressed, the former positive curvature being thus neutralised.

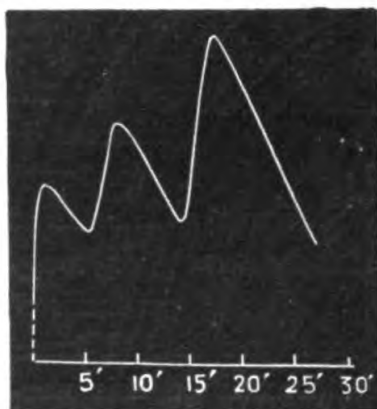

FIG. 246. Positive Heliotropic Movement of Terminal Leaflet of *Desmodium* Converted by Strong and too Long-continued Stimulus of Light into Oscillatory Movement

The supposed localisation of sensitiveness to light, and the transmission of excitatory effect.

I have fully explained the manner in which the effect of stimulus of light applied at a given point is transmitted to the distant growing organ, and the mechanics by which the curvature is induced. In connection with this, a peculiar phenomenon has been observed, which has led to the belief that in seedlings, like that of *Avena sativa*, the zone for the perception of heliotropic stimulus is confined to the upper region, or tip of the shoot. This conclusion is based on Darwin's observations on the unilateral effect of light on these seedlings. It was found that, generally speaking, when the lower part of the cotyledon was alone exposed to the unilateral light—the upper part being covered with a cap of tinfoil or with an opaque glass tube—there was little curvature induced; but when such light was allowed to act on the upper part of the seedlings the curvature was con-

nection with this, a peculiar phenomenon has been observed, which has led to the belief that in seedlings, like that of *Avena sativa*, the zone for the perception of heliotropic stimulus is confined to the upper region, or tip of the shoot. This conclusion is based on Darwin's observations on the unilateral effect of light on these seedlings. It was found that, generally speaking, when the lower part of the cotyledon was alone exposed to the unilateral light—the upper part being covered with a cap of tinfoil or with an opaque glass tube—there was little curvature induced; but when such light was allowed to act on the upper part of the seedlings the curvature was con-

siderable. From this it was concluded that sensitiveness to light was mainly confined to the upper part of the plant, and that this determined the curvature ; but to this conclusion, that it was the upper rather than the lower part that was sensitive to light, Darwin found and recorded several exceptions, which he regarded as inexplicable. In the case of six seedlings, for instance, of which the upper parts were covered with opaque shields, there was as much curvature induced as in seedlings which were unshielded. In these, therefore, there must have been sensitiveness in the lower parts also, thus negating the conclusion, drawn from other and more numerous experiments, that it was characteristic of the upper alone.

In order to see if these discrepancies were not capable of explanation, I undertook an investigation into the heliotropic action of light on the seedlings of *Avena sativa*. The method of screening the upper part of the seedlings from light, which has usually been employed by Darwin and others, labours under the disadvantage that the weight and contact of the tinfoil or the blackened glass tube are not unlikely themselves to set up a certain mechanical irritation, which may have the effect of causing an unknown disturbance in the result. I was therefore desirous of keeping the delicate seedling free from the irritating contact of caps in the course of my own experiments. For this reason I arranged for the localised application of light on upper or lower or both parts of the organ at will, by the method which has already been described of throwing a pencil of light on the required spot in the plant placed in the heliotropic chamber (p. 592). The resultant movement of the organ was now continuously observed and recorded, by means of the Recording Microscope which has been described.

For the sake of clearness I may here forestall matters, by saying that the observed results fall under two types, according to whether the given specimen possesses feeble or high conductivity—that is to say, power of transmitting stimulus to a distance. Taking first the case in which the

organ possesses feeble conductivity, I have found that when the extreme tip was stimulated unilaterally, by using a pencil of light from a sixteen candle-power incandescent electric lamp, the result was a negative movement—that is to say, a movement away from light. This is exactly parallel to the response to stimulus of the unopened flower-bud of *Crocus* and the root-tip of *Sinapis*, in both of which the indirect effect at the growing region, of stimulus applied on the tip, was seen to be a convexity of the side acted upon, with consequent negative movement of the tip.

I next applied unilateral stimulus to the same specimen a little lower down, and now, owing to the better conductivity of this part of the tissue, the excitation itself was transmitted to the growing region, inducing concavity and positive heliotropic movement. The same effect was found to be produced when stimulus was applied on the growing region itself. It must be remembered that in this case the conducting power of the tissue is not high, hence there is no transmission of stimulus to the distal side, by which, as we have seen, the positive curvature would be neutralised. The long-continued action of light on one side here tends only to increase the positive curvature to a maximum. Thus when one side of the entire seedling is acted upon by light, while the response of the extreme tip tends to induce a slight negative, all the other parts, from immediately below it to the growing region, conspire together to exhibit a much stronger positive heliotropic action. The result is therefore a movement towards the light. Thus we see that in the case of seedlings having feeble conductivity the curvature will be positive, whether it is the lower part only or the entire plant which is exposed to the one-sided action of light. In this fact we find the explanation of those exceptional cases observed by Darwin, in which the seedling was found to bend towards the light, in spite of the upper part being covered.

We shall next take up that type of response in which the tissue of the specimen is rather better conducting. In this case, when the upper part of the organ is locally stimulated,

the excitation is longitudinally transmitted to the growing region lower down, and induces a concavity there which increases with the duration of the stimulus; but if the stimulus of light be applied directly on the growing region itself, instead of on the upper part of the specimen, then, by reason of the transverse transmission of excitation to the distal side, we obtain a state of things in which there is no resultant curvature at all. In this case, then, the direct effect of stimulus on the proximal side of the growing region is balanced or neutralised by the transmitted effect on the distal side; but this condition of balance will be upset if the unilateral stimulus of light, hitherto acting on the growing region alone, be allowed to act simultaneously on the upper part of the specimen also. The longitudinally transmitted stimulus from the upper part being now added to the direct excitation of the proximal side of the growing region, causes an over-balance of responsive effect on that side, resulting in a positive heliotropic curvature. The fact that there is no heliotropic movement, when only the lower part of the seedling is unilaterally acted on by stimulus, is thus not due to any absence in that region of heliotropic sensibility, but to the neutralisation of the proximal effect by the equal excitation of the distal. Such transmission of stimulation along the length of the organ is observed to take place in a specially marked manner in the cotyledon of graminaceous plants. We may account for this by the fact that such organs are parallel-veined—that is to say, the fibro-vascular elements, which we already know as good conductors of excitation, run along their length. This is no doubt the reason of their ready transmission of stimulus to a distance.

Negative heliotropism of a radial organ.—We have seen that when moderate stimulus acts unilaterally on a growing organ a positive curvature is induced, and that, with stronger or long-continued stimulation, this reaches the distal side, producing neutralisation. We shall now proceed to trace out the continuity of responsive heliotropic effects, from the positive curvature to the negative, through the inter-

mediate phase of neutralisation. We have seen that at a certain definite intensity of illumination the excitations of proximal and distal sides, balancing each other, cause neutralisation. If now the intensity of stimulating light be further increased, it is easy to see that while the stimulation transmitted to the distal side, with the concomitant contraction, is being increased, the excitatory contraction of the proximal will be at the same time decreased, owing to the fatigue brought on by over-stimulation. The result then will be the greater contraction of the distal side, with a consequent negative heliotropic curvature of the organ.

These considerations show the mechanical action of heliotropic stimulus in causing : (1) positive heliotropic curvature under moderate illumination ; (2) the neutralisation of this action under stronger illumination ; and (3) the conversion of the normal positive into negative when illumination is excessive. Thus the observation made by Oltmanns, on young seedlings of *Lepidium*, subjected to varying intensities of light, an observation of which there has been hitherto no satisfactory explanation, is fully accounted for. Oltmanns subjected a row of seedlings of *Lepidium* to the action of sunlight, diverging from the focus of a lens. The seedlings nearest the focus were thus subjected to the strongest stimulation, those further from this point being under gradually decreasing intensities of light. It was then found that the seedlings nearest the focus, which were subjected to the strongest degree of light, exhibited negative heliotropic curvature, while others, further away, and therefore subjected to less intense illumination, did not show any effect at all (neutralisation), and others again, which were still further away, and therefore under only moderate intensity of illumination, exhibited positive curvature.

Gradual transition from positive to negative, through intermediate phase of neutrality.—I shall, however, give a still more conclusive verification of the theoretical inferences which I have just set forth regarding the gradual transition of positive heliotropic response into negative, through the

intermediate neutral, in consequence of the increasing internal diffusion of stimulus with increasing intensity of stimulating light. This I shall do by a continuous record taken from a single plant under changing conditions of increasing illumination, in which record, further, we shall be able to follow all the phases of responsive change, from positive to negative. Taking a hypocotyl of *Sinapis nigra*, I subjected it to the unilateral action of light from a sixteen-candle-power incandescent electric lamp, placed at a distance of 10 cm. from the specimen. The plant, hitherto quiescent, began to move towards the light, as shown by the up curve in the record (fig. 247), the maximum being attained in the course of fifty minutes. The intensity of incident stimulus was now increased, by bringing the lamp to a distance of 6 cm. from the specimen, at the moment marked with the downward arrow. It will be seen that this resulted in a process of neutralisation of the preceding response, and that this became complete in the

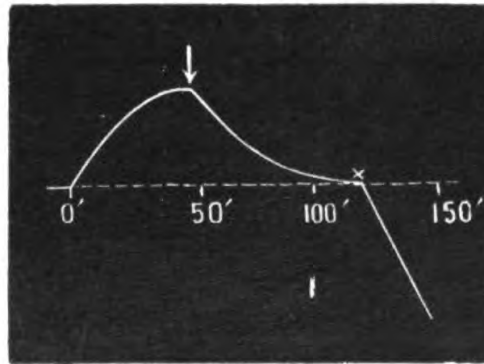

FIG. 247. Response of Hypocotyl of *Sinapis nigra*

The first curve shows positive response induced by incandescent electric lamp at distance of 10 cm. Increased intensity of light applied at arrow (\downarrow) by bringing lamp to distance of 6 cm. causes neutralisation. Reversal, or negative response, when sunlight applied at \times .

course of a further exposure of seventy minutes, the hypocotyl being then erect and free from curvature, having thus placed itself at right angles to the incident light. Still stronger illumination of sunlight was now applied, at the point marked \times . This induced, as is seen in the down curve, a very marked reversed or negative heliotropic response.

Thus, in other words, in an identical organ, under different conditions of illumination, the plant turning towards the light exhibits the *positive heliotropic*, at right angles to the light the *dia-heliotropic*, and away from the light the *negative*

R R

heliotropic effect, thus conclusively proving that the induction of these three effects is not due to the presence of three distinct and characteristic sensibilities. These different responsive movements are thus traced to a single phenomenon of contractile response.

This may be made equally clear from another point of view, as illustrations namely of the general law that response takes place by the contraction of the more excited, or the relatively more excited. With moderate stimulation it is the proximal side of the organ that is excited, and, becoming concave, gives rise to a positive heliotropic curvature. On the application of somewhat stronger stimulation, however, when excitation is transmitted to the distal side, there is a case in which the excitation of the proximal and distal are equal, and the differential excitation being thus zero, there is no resultant response. The organ, standing thus at right angles to the light, and moving neither towards nor away from it, will now appear to be either dia-heliotropic or else irresponsive to heliotropic stimulus.

But under still stronger stimulation two effects are induced simultaneously: (1) a physiological anisotropy, by the fatigue and loss of excitability of the proximal, in consequence of which the distal becomes the more excitable; and (2) the internal diffusion of the stimulus, which, now acting on the physiologically anisotropic organ, induces concavity of the distal, that is to say a negative heliotropic curvature.

I shall now proceed to give further examples of that transverse transmission of excitation, in consequence of which an organ appears either to be irresponsive to heliotropic stimulus or to give negative response.

Organs apparently insensitive to light.—Many vegetable organs exhibit no resultant movement under the action of light, and are therefore supposed to be insensitive to it; but this inference could be accepted only on the theory of a specific sensibility, in which case some organs would be without it, while in others it would be characterised by certain inherent positive or negative properties. We have

seen, however, that such a theory is untenable. The apparent absence in some organs of sensibility to light may perhaps, then, be explicable, not as want of sensitiveness, but as the neutralisation of effect, by the equal excitation of the two opposite sides.

In the case of certain seedlings of *Avena*, it has already been shown that the so-called insensitiveness of the lower part of the organ was due to this cause. Many tendrils, again, according to Mohl and others, are heliotropically insensitive. Thus, for example, on subjecting the tendril of *Passiflora* to lateral sunlight, there is practically no responsive movement; but as the tendril is a highly conducting organ, we might expect that its responsive movement would be neutralised by the transverse transmission of excitation. It occurred to me that this question, as between a characteristic insensitiveness, and a sensitiveness with equal excitation of two sides, might be tested by artificial reduction of the conducting power by cooling. Under such circumstances, if any sensitiveness existed, a one-sided excitation by light would remain localised, and induce concavity, or positive heliotropic movement. On carrying out this experiment, I found that the selected tendril of *Passiflora* now exhibited a marked positive heliotropic movement by the induced concavity of the side acted upon.

Negative heliotropism of tendril of *Vitis*.—The tendril of *Vitis* is adduced as the type of those organs which exhibit the negative heliotropic effect. I therefore undertook an investigation on this organ, to determine whether it would not be possible to explain its negative movement without postulating the existence, in its case, of a specific heliotropic sensibility of negative sign. When sunlight strikes it on one side it is found that it moves away from the light. If, now, this movement be really due to the intensity of stimulus, causing it to be rapidly conducted to the distal side, and at the same time giving rise to the fatigue of the proximal, then we should expect that the application of moderate unilateral illumination would induce the positive heliotropic movement.

R R 2

The crucial test would thus lie in the observation of the responsive movement under moderate unilateral stimulation.

I placed a tendril in a dark room, and subjected it to light of moderate intensity from a sixteen-candle-power electric lamp, placed at a distance of 15 cm. This induced an active movement of the tendril towards the light, or positive heliotropic response. I then brought the lamp nearer, to a distance of 5 cm., thus increasing the intensity of light. The active positive movement was now quickly reversed into a movement away, or negative heliotropic response. This experiment once more demonstrates the fact that positive and negative heliotropic responses are not due to two specific sensibilities of opposite sign.

The negative heliotropic curvature in an organ originally radial, which we have just studied, was due to the physiological anisotropy induced by the stimulus itself; but there are organs in which anisotropy is already developed in various degrees of perfection, and in them we shall be able to observe varying intensities of this negative heliotropic effect. This will be discussed in detail in succeeding chapters.

SUMMARY

Negative curvature is induced under the action of light in two different ways : (1) by the indirect effect of the moderate stimulation of the tip of root or shoot ; and (2) by the transversely transmitted effect of strong or long-continued stimulus acting on the distal side of an organ, when the proximal has become fatigued. The parallelism between geotropic and heliotropic effects is thus incomplete.

The direct effect of stimulus, unilaterally applied, may be longitudinally transmitted, and cause responsive movement in the distant growing region.

The unilateral effect of stimulating light on the growing region varies with its intensity, as follows :

1. Moderate intensity induces the normal positive responsive movement.

2. (a) Stronger or long-continued stimulus, on account of its internal diffusion by transverse transmission, causes neutralisation of effect. In other words, the organ, after first moving towards the light, returns to its original position at right angles to it, or assumes the dia-heliotropic attitude. This neutralisation, depending as it does on transverse conduction of stimulus, can only take place when the stimulus is very strong, or when the organ is highly conducting. The first of these considerations explains the fact that while moderate stimulation causes positive curvature, stronger stimulation has no resultant effect. The effect of the second factor (the higher conductivity of the tissue), which is brought about by a warmer season, is seen when the transversely transmitted effect causes neutralisation. The apparent absence of heliotropic effect in various tendrils is due not to any want of sensibility, but to this neutralisation by transverse conduction of the effect of stimulus.

(b) The transverse transmission of stimulus to the distal side is sometimes attended by oscillatory responsive movements, owing to periodic or alternate fatigue.

3. With still stronger unilateral stimulation, the organ becomes for the time being anisotropic, owing to the fatigue of the proximal side. The internally diffused stimulus then induces negative curvature, through the relatively greater excitability and contraction of the distal half of the organ. The negative heliotropic movement of the tendril of *Vitis* is explained by these considerations. This tendril, under moderate unilateral stimulus, exhibits positive heliotropic movement; but stronger stimulation, in consequence of transverse transmission and unilateral fatigue, gives rise to negative heliotropic movement.

The statement that the different responsive curvatures brought about by light are not due to different sensibilities possessed by different organs, is proved by the fact that the same organ exhibits continuous changes, from positive to negative through neutral, under different intensities of stimulation.

CHAPTER XLIV

EFFECT OF INVISIBLE RADIATION AND EMANATIONS

Effect of temperature and its variations—Demonstration of fundamental effect of thermal radiation on growth—Response to successive uniform stimuli of thermal radiation—Effect of continuous unilateral stimulation—Effect of electrical waves on growth—Response of *Mimosa* to electric radiation—Action of high frequency Tesla current.

WE have now studied the curvature effects induced in plants by those ethereal vibrations that lie within narrow limits, and are known as visible light. There are, however, other vibrations outside this range, the ultra-violet and the infra-red. The excessively quick vibrations beyond violet are known to produce very marked heliotropic effects. But below the red, again, we have comparatively long waves which give rise to thermal, and others, still longer, to electrical radiation.

In studying the curvature-effects on plants of invisible radiations of low frequency, it is necessary to distinguish carefully between the action of radiation as such and the subsidiary effect of temperature.

Effect of temperature and its variation.—In this investigation it becomes especially important to distinguish the temperature from the radiation-effect, and I shall presently describe a very decisive experiment by which the effects of the two may be clearly distinguished. The effect of temperature up to the optimum is, as we have seen, to increase the internal energy of the plant, in consequence of which there is an acceleration of the rate of growth; but *variation* of temperature acts as an external stimulus, and would thus be effective in inducing a transient retardation of growth. A part of the stimulus, however, is held latent, as

we have seen, in the tissue, so long as the temperature is below the optimum, to give rise later to an acceleration of the rate of growth. Hence, frequent variations of temperature below the optimum will, by reason of these alternate retardations and accelerations, produce little total effect on the rate of growth; but above the optimum, the stimulating action of variation of temperature will retard growth, and as there is here no latent factor, this will not be made up by any subsequent acceleration (p. 461). Hence, the total effect of such variation will be a retardation. This consideration explains the different conclusions to which observers have been led as to the effect of frequent variation of temperature on growth.

Demonstration of fundamental effect of thermal radiation on growth.—In the usual experiments on the effect of thermal radiation on the induction of growth-variation, a difficulty arises in distinguishing between the effect of thermal radiation and that of temperature. In order, then, to determine the fundamental effect of thermal radiation, the experiment must be so arranged that the radiation whose effect is to be observed causes no change of temperature. I have been able to accomplish this by mounting the growing organ in a plant chamber surrounded by a wide heating coil of platinum wire. Between the coil and the specimen there is a cylinder of mica, which is opaque to thermal radiation. By means of a string attached to it from above, this cylinder may be alternately lifted and lowered. The plant is attached to the Crescograph, and a balanced record is taken of its growth when the shield is down, and when, by maintaining a current through the heating coil, the chamber has already been brought to a steady temperature of 34° C. As everything inside the chamber has now attained a steady temperature, the movement of the shield up and down will produce no change in this condition. By now raising the mica shield, we can subject the specimen to the action of thermal radiation, which proceeds from the heated spiral wire, without producing any variation of temperature. When the

mica shield is again dropped the action of radiation on the organ is cut off.

Experimenting in this manner, and obtaining a horizontal record with the shield down, we find, when the shield is lifted, that there is at once an upsetting of the balance, which indicates a retardation of growth. When the shield is once more allowed to drop, the deflected record becomes again horizontal, indicating the restoration of the original rate of growth. This experiment conclusively shows that radiation by itself acts as an external stimulus, retarding the rate of growth. It will be remembered that this is quite distinct from the effect of temperature, which, up to the optimum, always induces the opposite result, namely, an enhancement of the rate of growth. The same distinction is also to be borne in mind in dealing with the excitatory effect of light, for incident light also has the twofold effect of causing external stimulation and at the same time raising the temperature of the tissue.

Response to successive uniform stimuli of thermal radiation.—Having thus demonstrated the fundamental action of thermal radiation, we shall now study the effect of

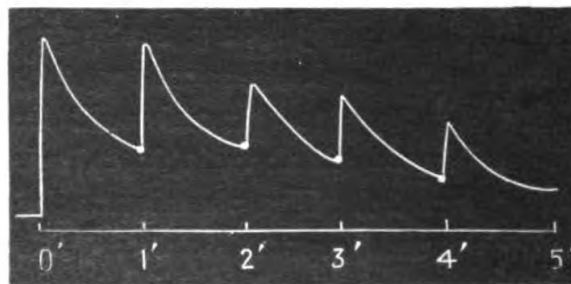

FIG. 248. Responses to Successive Uniform Stimuli of Thermal Radiation in Pistil of *Musa*

the unilateral application of this form of stimulus, which will be found similar to that caused by visible light. The responsive effect of successive uniform stimulations may be studied by placing a

V-shaped platinum wire with its point opposite to the region of growth, and heating it periodically by definite currents of short duration; the flashes of thermal radiation thus produced bring about the usual responsive concavity. These responses and recoveries are recorded in the usual manner. I give in fig. 248 a series of such responses

of the pistil of *Musa*, in some specimens of which the growing region is found to be narrow and sharply defined. In this case the V-shaped radiator was placed opposite to this region. In these responses we see that there is a considerable amount of recovery after each transient stimulation, and also a certain degree of fatigue.

Effect of continuous unilateral stimulation.—We shall next study the effect of continuous unilateral stimulation. For this experiment I took the hypocotyl of *Tamarindus indica*. As the growing region in this case is extended,

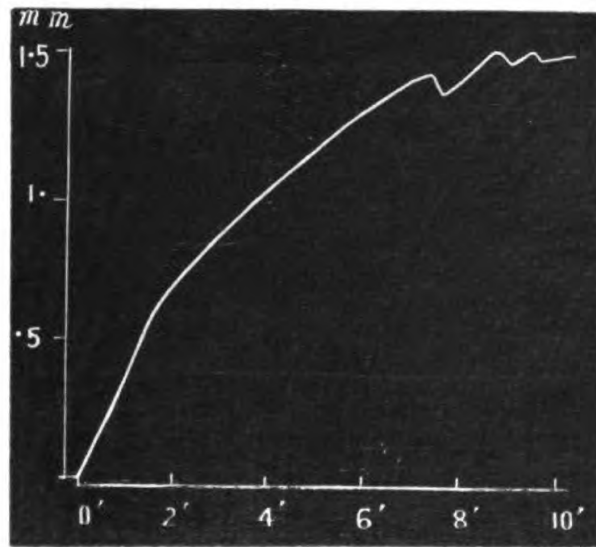

FIG. 249. Response of Hypocotyl of *Tamarindus indica* to Continuous Stimulation of Thermal Radiation

I used a thermal radiator, which consisted of a linear platinum wire, 5 cm. in length, placed parallel to one side of the growing region. Under the action of continuous unilateral radiation, an increasing positive curvature—that is to say, towards the stimulus—was induced, till a maximum effect had been attained (fig. 249). With specimens of other plants I obtained either the neutralisation or the reversal of this curvature, as it might happen, in consequence of the internal diffusion of stimulus to the distal side. This neutralisation is brought about by equal excitation of the proximal and distal sides, in precisely the same manner as in the

case of light. It is seen in the return of the organ to its original position, or by oscillations about that position as the mean ; but in cases where the proximal becomes fatigued, the responsive contraction of the distal gives rise to a negative curvature. In all these cases we see thermal radiation inducing the same curvature effects—positive, neutral, and negative—as were found to be induced by visible light.

Effect of electric waves on growth.—I shall next describe the effect of Hertzian waves in inducing responsive curvatures ; and first, in order to obtain the fundamental effect on growth itself, I took an electric radiator consisting of a rod 5 cm.

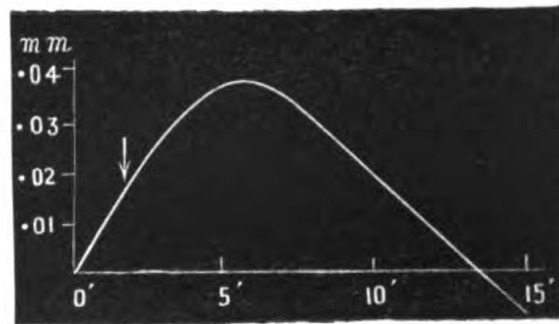

FIG. 250. Effect of Electric Waves on Growth

Connection with electric vibrator at downward arrow (\downarrow) is seen to arrest growth and to induce contraction, by which the specimen undergoes an actual shortening.

in length, excited by oscillatory discharge from a Ruhmkorff's coil. The specimen was a flower-bud of *Crinum* Lily, whose upper and lower ends were connected by means of thin wires with the two ends of the electric radiator. The natural growth-record under unbalanced conditions was first taken (fig. 250), and the specimen was now subjected to the action of electric waves at the point marked in the record with a downward arrow. It will be seen that this gradually diminished the rate of growth, till at the end of five minutes it was completely arrested ; and as the action of the electric waves continued, the contractile effect by which growth is arrested is seen to be carried further, actually bringing about a shortening in the length of the specimen.

Response of *Mimosa* to electric radiation.—In the last case, in order to subject the specimen to the intense action of electric waves, the radiator was electrically connected with the responding organ, which was diffusely stimulated by it, and exhibited a longitudinal response of contraction. If, however, we wish to observe the effect of the unilateral action, it will be necessary that the radiation shall act on one side only. A difficulty is here met with, however, owing to the relatively greater length of these electric waves, which, like those of sound, do not cast shadows, but curl round corners. In order to produce unilateral action, then, the length of these waves has to be reduced to a minimum. By using small spheres of platinum as the source of radiation, I succeeded in obtaining short electric waves of about 1 cm. in length; but the intensity of such radiation is somewhat feeble, and with them I could only occasionally obtain responsive curvatures of growth. I was, however, more successful in obtaining responsive effects from the pulvinus of *Mimosa*. When the small radiator which I have described was placed at a distance of a few centimetres from the lower half of a pulvinus, and when the radiator was allowed to act, a depression of the leaf of this plant occurred after an exposure of nearly half a minute to the continuous action. It should be mentioned that for the demonstration of this effect it is the younger leaves which are suitable, the older not being sufficiently sensitive. With regard to the electric waves, it is to be borne in mind that to them water is opaque, while ebonite is highly transparent. Hence the interposition of a sheet of ebonite, between the radiator and the plant, does not stop the responsive action, while a parallel-sided trough of water in the same place would effectually prevent the passage of the rays, and thereby put an end to the action.

Action of high frequency Tesla current.—If one electrode of a Tesla coil be put in connection with the growing organ, this electric variation of high frequency is found to cause an arrest of growth. Even the contiguity of wires carrying

these high frequency currents is often found to retard growth. It is probable that this is due to certain material emanations that proceed from the wire. A coil of iron wire was made to surround the growing organ, and during the excitation of this coil the normal growth-rate was found to be retarded; but there was no such retardation when a glass cylinder was interposed between the specimen and the coil. During the short period of the experiment there was but little rise of temperature within the coil, and the retardation of growth could not have been due to any thermal radiation.

SUMMARY

Variation of temperature acts as a stimulus. Below the optimum the direct effect of variation of temperature is a retardation of growth, and the negative after-effect, owing to absorption of stimulus, is an acceleration of growth. Hence repeated variations of temperature below the optimum have little resultant effect on growth.

Above the optimum, stimulus is not held latent, and there is no negative after-effect of accelerated growth. Hence, repeated variations of temperature above the optimum will retard growth.

While rise of temperature up to the optimum accelerates growth, thermal radiation, as such, acts as a stimulus, and retards growth.

The unilateral action of thermal radiation is similar to that of luminous radiation—that is to say, thermal radiation, when of moderate intensity, gives rise to positive, and when strong, to neutral, or negative movement.

Electric waves induce retardation of growth. The unilateral application of electric radiation is also found to induce responsive movements.

High frequency Tesla currents retard growth.

CHAPTER XLV

ON PHOTONASTIC PHENOMENA AND ON DIURNAL SLEEP

Photonasty and para-heliotropism—Response of *Tropaeolum majus*—Responses of plagiotropic stems : (a) *Mimosa*—(b) *Ipomoea*—(c) *Cucurbita*—Daily periodic movements of plagiotropic stems—Responsive movements of pulvinated organs—Pulvinated organs showing positive heliotropic movement : (a) Response of terminal leaflet of *Desmodium*—(b) Response of leaflet of *Robinia*—(c) Responsive movements of leaflets of *Erythrina indica* and *Clitoria ternatea*—The negative heliotropic type of response : (a) Response of pulvinus of *Mimosa*—(b) Diurnal sleep of *Oxalis*—(c) Diurnal sleep of *Biophytum*—Directive versus non-directive action of light—General view of responsive curvatures induced in different organs by unilateral application of light.

I SHALL now enter upon the investigation of a very large class of phenomena, brought about by the action of light, which have hitherto been regarded not only as obscure, but also as totally unrelated to each other. These phenomena may be described in a general way as the exhibition of the differential effects of light on anisotropic or dorsi-ventral organs. Such effects may again be divided for convenience into two classes, according as they are exhibited either by growing or by mature and pulvinated organs. The responsive curvature in the former of these cases, due to the differential growth induced by light, we shall designate as *photonastic*. It must be understood that there is in reality, as we shall see, no fundamental difference between the responsive curvatures induced in growing organs, whether radial or dorsi-ventral, and those in pulvinated organs ; but it is nevertheless suitable for the purposes of this investigation to treat them under separate headings.

Photonasty and para-heliotropism.—In experimenting with dorsi-ventral shoots, De Vries found that when light was applied to the lower or normally shaded surface of, for

example, runners of *Lysimachia Nummularia*, the result was a concavity of that side ; and when strong light was applied on the upper surface, the result was still the concavity of the normally shaded, and now distal, side. He obtained similar results also with midribs of leaves. Again, in the case of *Marchantia* thallus, it was found by Frank and Sachs that it was the normally shaded side which became concave, whether light was applied above or below.

De Vries explained the curvature away from light, when the dorsal surface was illuminated, by the assumption that the organ was negatively heliotropic ; but the concave curvature induced when the lower surface of the same organ was illuminated necessitates the description of that surface, at least, as positively heliotropic. Thus we are driven to assume that the two surfaces of the organ are endowed at the same time with two opposite heliotropic properties, the obvious impossibility of which has led to the idea that in this class of phenomena we have not to deal with the directive action of light at all.

In the case of certain pulvinate organs I shall be able to show an exact parallel to these phenomena—that is to say, an induction under light of concavity in the lower surface, whether light be applied from above or below. This being so, it is clear that the only theory of the phenomena which could be satisfactory would be one which would apply equally to both.

Closely connected with the same inquiry is the phenomenon of para-heliotropism, or the so-called diurnal sleep. Under the intense illumination of midday, the leaves or leaflets of certain plants take up positions which outwardly resemble those which they adopt at night. In some cases again, in which the normal daylight position is outspread, and the nocturnal one of downward folding, the effect of light at midday on the leaflets is to induce a folding upwards. These phenomena have not yet been satisfactorily explained. Darwin suggested that such habits had been acquired for the special purpose of avoiding too intense an illumination. I shall be able, however, to offer a simple and inclusive ex-

planation, applicable to the phenomena both of photonasty and of para-heliotropism. It will be noticed that in the first case we have to deal with the effect of light on all *growing* dorsi-ventral organs, and in the second with its effect on *mature* dorsi-ventral pulvini; and in dealing with both these classes I shall pass step by step from the consideration of simple to that of more complex types.

The response of *Tropæolum majus*.—Sachs found that when the stem of *Tropæolum majus* is exposed to intense and long-continued unilateral illumination, a negative heliotropic curvature is induced; but when the plant is exposed to moderate unilateral illumination it exhibits positive heliotropic movement. The explanation of this difference is made quite clear from the experiments which I have already described, with reference to seedlings of *Sinapis nigra* and to the tendril of *Vitis*; for it has been shown that in these cases moderate unilateral stimulus of light caused a positive heliotropic effect; whereas, under the action of intense stimulation, a transient anisotropy was induced, on account of which the excitability of the over-stimulated proximal side was diminished. Hence the distal side was rendered the relatively more excitable, and the intense stimulus becoming internally diffused caused a concavity of the distal side, and gave rise to a negative heliotropic effect (p. 609).

The negative effect is thus due to anisotropy, and internal diffusion of excitation from the proximal to the distal sides, this latter factor evidently tending to be facilitated by any agency that increases the conductivity of the tissue (p. 603). We have also seen elsewhere that this power of conductivity is very much augmented in summer (p. 475). In connection with this, it is interesting to note that the negative heliotropic curvature of *Tropæolum majus*, due to transmitted excitation, has only been observed by Sachs during summer, while in autumn the effect observed by him was always positive, owing to stimulus remaining localised. Another instance of the same kind is furnished by the hypocotyl of Ivy (*Hedera helix*), which from the normal positive heliotropic curvature, in

autumn, as observed by Darwin, passes into the exhibition of a strongly negative heliotropic condition in summer.

Responses of plagiotropic stems.—It is found that under feeble diffuse illumination the Gourd-plant (*Cucurbita*) for example, grows erect. In the open, however, if, on account of its own weight, or by the action of the wind, it is once made to bend, the stem is brought into a position where its upper surface is constantly acted on by strong light, whilst its lower is shaded. By the continuous action of the stimulus of light the upper surface is now rendered less excitable, and a permanent anisotropy (plagiotropism) is induced, such as we saw transiently exhibited in the hypocotyl of *Sinapis* (p. 609) under the short experimental exposure of a specimen to intense unilateral illumination. It has already been shown in Chapter VII. that such plagiotropic stems are more excitable on their lower or shaded side, and that under diffuse stimulation response is by concavity of that side. Hence a recumbent plagiotropic stem of this description, acted on by strong vertical light, which becomes internally diffused, will always exhibit concavity of the lower surface, in consequence of which it will be closely pressed against the ground.

Such a plagiotropic organ, then, acted upon dorsally, shows a concavity of the ventral surface, or a negative heliotropic effect; but if the ventral, or normally shaded, side be itself acted upon directly by light, the result will still be the concavity of the lower or more sensitive surface—that is to say, a positive heliotropic effect. In the former case, then, we have an example of the differential response of an anisotropic organ to diffuse stimulation, by concavity of the more excitable; and in the latter, the direct contraction and concavity of the surface acted upon, which happens in this case to be also the more excitable. This will explain why, in the midribs of leaves, in plagiotropic shoots of *Lysimachia*, and in the thallus of *Marchantia*, we always observe the concavity of the shaded and more excitable side, in response to the action of strong light, whether it is applied from above or below.

(a) *Mimosa*.—This fact, that in plagiotropic stems under the diffuse stimulation of light it is the more excitable shaded side which becomes concave, I have been able to demonstrate by numerous other experiments; for example, taking four creeping stems of *Mimosa*, I tied them in such a manner that their free ends should be vertical. The shaded sides of the four specimens were turned so as to face each a different point of the compass—east, west, north, and south. Subjected thus to the diffuse stimulation of light from the sky, they all executed curvatures. The specimen whose under side faced the east became bent towards the east. The same happened to those which faced north, south, and west—that is to say, they became curved towards the north, south, and west respectively. The fundamental responsive action by which all these were determined was the induced concavity of the under, or normally shaded, side, which is the more excitable.

(b) *Ipomœa*.—Another example was that of the creeping stem of *Ipomœa*. This I tied up vertically with its end free, at 10 A.M., the normally shaded side being represented in the diagram to the left (fig. 249). For purposes of the record I placed behind it a piece of paper, on which its different positions were traced from time to time. It will be seen that by 1 P.M. it had become considerably curved, the normally shaded side being concave. This concavity had become still more

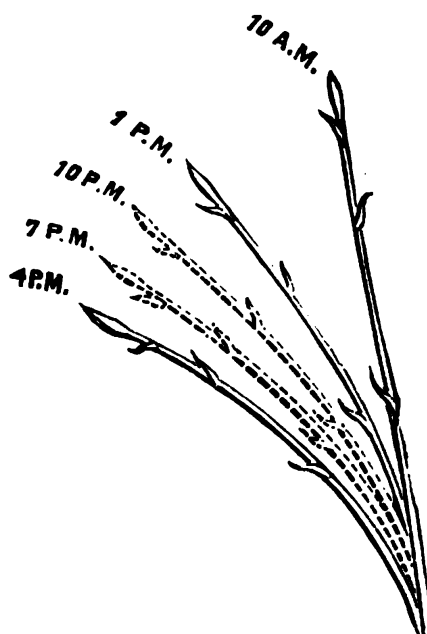

FIG. 251. Response to Diurnal Light and Darkness of Plagiotropic Stem of *Ipomœa* held vertical

The curvature is seen to increase with the progress of day, the shaded side to the left becoming more and more concave. The dotted figures represent positions of gradual recovery at night.

S S

marked by 4 P.M. The next record was taken at 7 P.M., when the sun had gone down, and the source of stimulus was therefore removed. The dotted portion of the record shows the partial recovery which had now taken place, and whose extent was still further increased by 10 P.M.

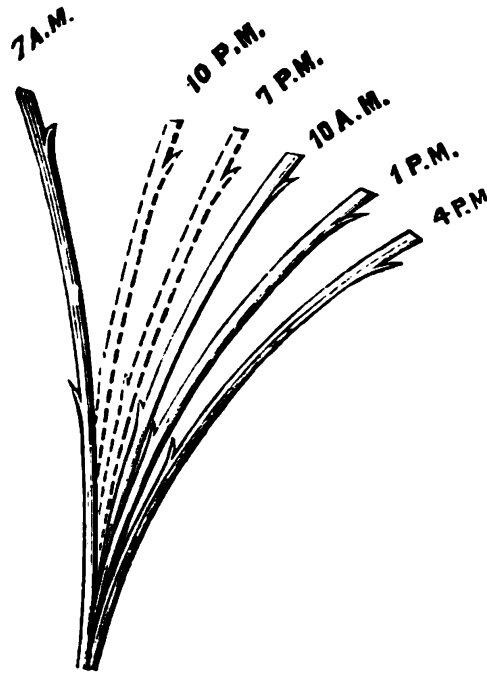

FIG. 252. Response to Daily Periodic Light and Darkness of Plagiotropic Stem of *Cucurbita maxima*

The specimen held horizontally, with plane of dorsi-ventral division vertical, the ventral surface being here represented to the right. The action of gravitation is thus practically eliminated. Cumulative effect of day's illumination is seen in progressive concavity of normally lower or shaded surface. Dotted figures show positions of recovery after dark.

(fig. 250). Owing to this particular arrangement of the plant it will be seen that the responsive heliotropic movement must take place in a horizontal plane, and that on it geotropism will have no influence. The free end of the plagiotropic stem had been naturally somewhat curved upwards, and this appeared, when placed sideways, as a slight curve to the left, in its position at 7 A.M. Under the stimulus

This partial undoing of the induced curvature is mainly due to the recovery which is always observed on cessation of stimulus. It might, however, be urged that geotropic action, absent when the plant was vertical, and coming into increasing effectiveness with its growing horizontality, played a large part in bringing it about. In order, then, to eliminate this element, I next experimented on a stem of *Cucurbita*.

(c) *Cucurbita*. — This plagiotropic stem was held horizontally and sideways, in such a way that the plane which divided its dorsal and ventral halves was vertical. The shaded side is here represented in the diagram to the right

of daylight by 10 A.M. the stem is seen to have taken up a strongly curved position, with concavity of the shaded side. This process is seen from the figure to have been progressive, but on the approach of darkness there was recovery, the return being considerable at 7 P.M., and still greater at 10 P.M. It may be stated here that such recoveries are never quite complete, part of the curvature being fixed by growth. Thus in a naturally growing plagiotropic stem, the portion which was one day slightly lifted above the ground is on the next, owing to this residual effect, made to lie closely against it, so that by the action of light the growing stem is pressed progressively closer to the earth.

Daily periodic movement of plagiotropic stem.—From this demonstration of light-curvature and recovery, it will be seen that the free organ has a daily periodicity in virtue of which, in the daytime, it moves gradually downwards, and at night, owing to recovery, upwards. In this plagiotropic stem, then, we see, as will be shown later, the first induction of that nyctitropic movement which is more strikingly displayed in dorsi-ventral leaves.

Responsive movement of pulvinated organs.—The demonstration which I have just made of the peculiar responses of anisotropic organs to the stimulus of light, as exemplified in the case of plagiotropic stems, will be found still more strikingly applicable to pronouncedly dorsi-ventral organs like pulvini. In the last-named instance, indeed, as motility is great, the investigation has the advantage of concerning itself with responsive effects which take place very quickly.

From what has already been said, we shall be prepared to meet with two different types of responses, according as the transverse conductivity of the organ is feeble or considerable. In the former of these cases, under unilateral stimulation, there is no internal diffusion of stimulus, and the side acted on, whether above or below, will respond by concavity ; but in the latter case—that is to say, where the transverse conductivity of the tissue is great—it will be the more excit-

able side which, under strong unilateral stimulation of either, will become concave. Supposing the lower side to be the more excitable, then, strong stimulation, whether of dorsal or of ventral, will bring about concavity of the lower; but here we must bear in mind the possibility of an effect which will be the result of moderate stimulus. The differential effect, which brings about the concavity of the lower, even when it is the dorsal surface that is excited, depends on the internal diffusion of stimulation, and this in turn is dependent not only on the conductivity of the tissue, but also on the intensity of the stimulus. If, then, a feeble or moderate stimulus be applied on the dorsal surface, even of a highly conducting organ, the result will be a concavity of that surface. The long-continued action of moderate stimulus will, however, bring about a gradual percolation, and the first response due to localised, will give place to the differential effect of diffuse, stimulus. If the stimulus again be very much stronger, this reversal will take place much more quickly. We thus see that responsive movements may be positive, neutral, or negative, according to the strength and duration of the stimulus.

Pulvinated organ showing positive heliotropic movement: (a) *Terminal leaflet of Desmodium*.—We shall now take the case of a pulvinus in which the conductivity is feeble, and in which we should therefore expect to obtain positive response. I have already given response-curves in illustration of this positive response, whether it be the upper or lower surface of the pulvinus which is subjected to light (p. 586). It was also shown that the leaflet moved towards the light, and that in such cases it was the pulvinus, and not the lamina, which was both the perceptive and responding region.

(b) *Response of leaflet of Robinia*.—The leaflets of *Robinia*, under the vertical light of the noonday sun, exhibit what is known as diurnal sleep—that is to say, they fold themselves upwards. This is simply an instance of the positive heliotropic effect common to all those pulvinated organs in which

transverse conductivity is feeble. I give here (fig. 253) a response-record obtained with a leaflet of *Robinia* under the action of sunlight from above. A similar response, but in a downward direction, is obtained when light is made to act from below; but as, under natural conditions, light always acts from above, the leaflets are found, when the acting daylight is sufficiently strong, to exhibit what is known as diurnal sleep, or the para-heliotropic effect, in an upward direction. I have obtained numerous similar records with other leaflets, which fold upwards under the action of sunlight.

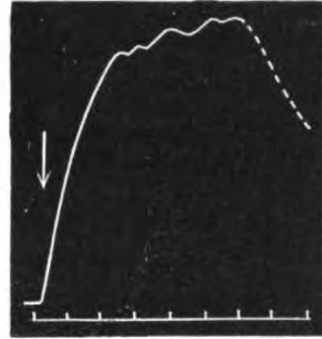

FIG. 253. Positive Heliotropic Response of Leaflet of *Robinia* to Sunlight Acting from Above

Dotted line represents recovery on cessation of stimulus. Time - marks represent intervals of five minutes.

(c) *Responsive movements of leaflets of Erythrina indica and of Clitoria ternatea.*—For the sake of simplicity I described the movement of *Robinia* leaflet as upward; but the actual direction is one which more or less accurately coincides with that of incident sunlight. As further examples of this particular type of diurnal sleep movement, I may mention the leaflets of *Erythrina indica* and *Clitoria ternatea* (Indian name *Aparajita*). Both of these are so remarkably sensitive that they follow the course of the sun, in such a way that the axis of the cup formed by the folding leaflets at the end of the petiole is coincident with the rays of light, and continues so from about 11 A.M. till about 3 P.M.

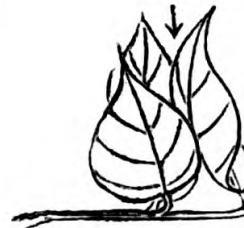

FIG. 254. Positive Heliotropic Response of Leaflets of *Erythrina indica*

The leaflets form a hollow cup with direction of incident sunlight as axis.

The negative heliotropic type of response.—We shall now pass on to the second, or negative, heliotropic type of response due to the internal diffusion of stimulus; and in order to show that there is a continuity between these and the

former instances, I shall here refer once more to the case, already mentioned, of the heliotropic response of the terminal leaflet of *Desmodium*, which in winter is always positive, but in a given experiment, under the conditions of greater transverse conductivity which are brought on in summer, exhibited, after two hours of continuous exposure to vertical sunlight, a neutralisation of the previous positive effect (p. 604).

(a) *Response of pulvinus of Mimosa.*—The second type of response will be the better understood if we first study in detail all its characteristics. As I have already said, these negative heliotropic responses result from the transverse diffusion of stimulus across the tissue, which brings about the concavity of the more excitable lower half of the organ. We can easily, in the continuous response-record to be given presently, detect this gradual process of the percolation of stimulus through the tissue, when light is applied from above. As there is in the case of *Mimosa* a considerable mass of intervening tissue between the upper and lower surfaces of the pulvinus, it follows that unless the stimulus applied be excessive, there will be a certain interval of time required for its passage. We should therefore expect that on the application of light to the dorsal surface there would be a local contraction and concavity of that side, raising the leaf up, and causing a preliminary positive response; but this movement will be arrested, and gradually reversed, so soon as the stimulus reaches the lower side, and begins to induce antagonistic contraction there; and after this, the greater excitability of the lower will be manifested by its greater contraction, as seen in the negative response, or depression of the leaf. All this will be clearly understood from the series of records given below.

It is necessary, however, before describing the effect of the continuous application of light from above, to analyse the responsive sensibilities of the two sides of this organ; and this is the more desirable since, in the case of *Mimosa*, it is commonly assumed that excitability characterises only

the lower half of the organ, the responsive movement of the pulvinus being due to that factor alone. In the course of the present work, however, I have frequently stated that the upper half also was excitable, and that the usual responsive movement was due to the *differential* excitability of the two. It is now easy, using localised stimulus of light, to submit this question to a crucial test.

First I took a record of the responsive movement of the leaf of *Mimosa*, when the upper half of the pulvinus alone was subjected to stimulus of sunlight. Fig. 255, *a*, shows

the moderate positive, or in this case upward, movement, which was the result of this stimulation. By means of a properly inclined mirror light was now thrown vertically upwards, so as to strike the lower half of the pulvinus. The consequent positive responsive movement, in this case downwards, is seen to be much stronger (fig. 255, *b*), on account of

the greater excitability of the lower half of the organ. The differential character of the responsive movement under externally diffused stimulation is shown in fig. 255, *c*, which is a record of the response given by the pulvinus when both its upper and lower sides were simultaneously acted upon by light.

It will be seen that in this record, then, we have a case of response to externally diffused stimulus. We shall next observe the effect of stimulus which has become *internally* diffused, owing to conduction from the upper to the lower

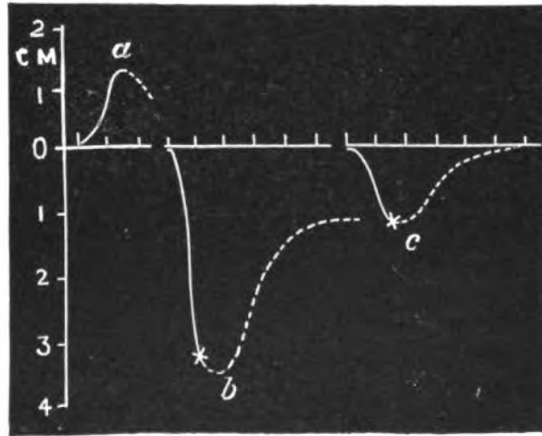

FIG. 255. Responses of *Mimosa* to Sunlight of not too long Duration

(*a*) Light acting on pulvinus from above; (*b*) light acting on pulvinus from below; (*c*) light acting simultaneously from above and below. Dotted line represents recovery on cessation of light.

half of the pulvinus. We have just seen that in the case of externally diffused stimulation both sides of the organ are acted upon at the same moment, and the differential response is downward from the beginning; but when continuous stimulus is applied on the dorsal surface, it is at first unilateral, and only afterwards becomes internally diffused. We therefore obtain in this case (fig. 256), as was theoretically

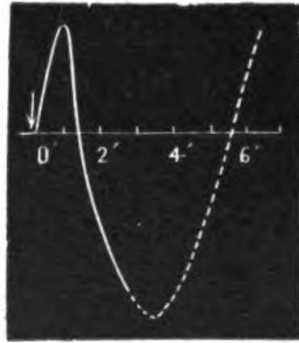

FIG. 256. Response of Pulvinus of *Mimosa* to Action of Continuous Light from Above applied at Moment marked with ↓

Positive heliotropic movement caused by excitation of upper half neutralised by transmission to distal side, and ultimately reversed owing to greater excitability of lower half. Dotted line represents recovery on cessation of light. Note final erection of leaf above original position as negative after-effect by absorbed stimulus.

inferred, all the phases of response, positive, passing through neutral, into negative. In the former, the movement is simply a continuation of the effect seen when stimulus was acting; but the latter, or negative, after-effect, being due to the increase of latent energy by absorption of incident stimulus, finds expression in an opposite movement. In the case of the response of growth we saw that the positive after-effect consisted of a persistent retardation, and the negative of an acceleration, of growth. In the case of pulvinated organs, however, the negative after effect is generally indistinguishable from the movement of recovery; but in the present instance we find it clearly exhibited in the fact that the after-effect not only causes recovery to the original position, but carries the leaf to a distance beyond.

The positive heliotropic response of the leaf, then, persists

A very interesting feature of this record is the after-effect, on the cessation of stimulus, which is represented by a dotted line. In Chapter XXXIV., while dealing with the detection of the latent factor, it was explained that there are two distinct after-effects, positive and negative (p. 457).

In the former, the movement is simply a continuation of the effect seen when stimulus was acting; but the latter, or negative, after-effect, being due to the increase of latent energy by absorption of incident stimulus, finds expression

only as long as it takes the stimulus to reach the distal side of the pulvinus. When strong concentrated sunlight is applied from above, therefore, the duration of this upward movement is reduced, and it appears only as a slight twitch. The same effect is produced under less intense light when, as in thinner pulvinated organs, the distance to be traversed by stimulus is not so great.

(b) *The diurnal sleep of Oxalis*.—In consequence of strong vertical illumination, as at noonday, negative heliotropic response, with downward folding of the leaves, takes place in those pulvinated organs in which there is internal diffusion of stimulus, and in which the lower side of the pulvinus is much more excitable than the upper. As examples of this, we shall take the cases of *Oxalis* and *Biophytum*.

In the former, if light of moderate intensity, say from a lamp, be applied on the dorsal or upper surface, an upward, or positive, heliotropic curvature is induced. If the same light be applied below, a positive heliotropic movement, in this case downwards, is again induced; but the fact that the lower side is much the more excitable is seen when the upper and lower surfaces are excited simultaneously, for there is now a downward movement (fig. 257, a). Thus external diffuse stimulation induces downward movement, and we shall also find that stimulus internally diffused has the same effect. This is seen by throwing a strong beam of sunlight on the upper surface,

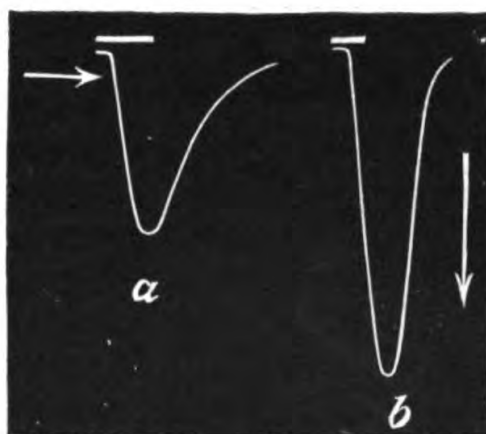

FIG. 257. Responses of *Oxalis* to Sunlight

- (a) Shows greater excitation of lower half and downward response when both upper and lower are simultaneously subjected to stimulus of light; (b) shows downward or negative response owing to internal diffusion of stimulus when upper surface only is acted on by strong light. Arrows indicate the directions of incident light.

when the leaflet is found to respond by depression (fig. 255, *b*). Here, then, we have a repetition of those movements which we have already seen in the case of plagiotropic stems, where strong illumination of whichever surface always had the same effect, that is to say the induced concavity in the lower.

(*c*) *Diurnal sleep of Biophytum*.—In the case of *Oxalis* and in that of *Mimosa* the responsive movement is more or less continuous; but in such a pronouncedly multiply-responding organ as that of *Biophytum*, the effect of internally diffused stimulus on the more excitable lower half of the pulvinus is to induce depression by a series of multiple

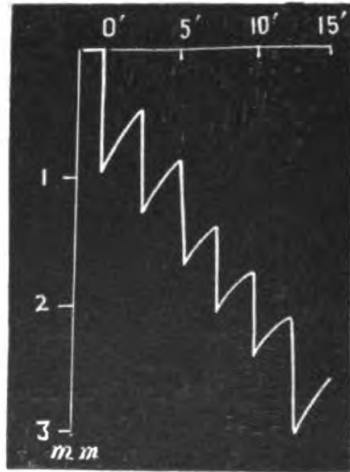

FIG. 258. Negative Multiple Response in *Biophytum* when Acted on from Above by Strong Sunlight

responses. This is well seen in the following record (fig. 258), where under the action of strong sunlight from above the leaflet is undergoing a progressive fall. A record of a similar effect in the case of *Biophytum* is seen in fig. 123, the fall being in that case represented by an up curve. The specimen there was somewhat sluggish, and there were three pulsations in the course of ten minutes, making an average of 3.3 minutes to each. In the present instance, however, there were six pulsations in the course of fifteen minutes—each, that is to say, having an average period of 2.5 minutes. Similarly in *Averrhoa* the fall of the leaflet occurs in a pulsating manner, an instance of which is given by Darwin.¹

The directive versus non-directive action of light.—It will be well at this point to enter into the question of arbitrary distinction which is commonly made as between heliotropic action in radial organs and the same action in the anisotropic or dorsi-ventral. It is clear, however, that such a distinction

¹ Darwin, *Movements of Plants*, p. 333.

is no longer possible when the fundamental unity of effects in the two cases has been perceived.

But it is customary to make a further distinction between these effects, on the ground that the movement of the radial is determined by, while that of the anisotropic is independent of, the directive action of light. In this matter again I shall be able to show further that no such line of demarcation can be drawn. It will then be seen that the differences between the two classes of phenomena are only apparent.

In the case of radial organs, we saw that the direct action of moderate stimulus of light, inducing concavity of the proximal, gave rise to positive heliotropic movement. The same is true of the similar direct action of a moderate intensity of light on, say, the pulvinus of *Mimosa*, where the upper and lower halves of the organ both exhibit positive response. With stronger light, again, the radial organ develops an induced anisotropy, by which the proximal side, owing to fatigue, becomes the relatively less excitable. Under this condition, the proximal side of the radial organ corresponds to the less excitable upper half of the pulvinus of *Mimosa*, and the distal to the more excitable lower half. This differentiation is seen to be continuous throughout the three cases of the radial organ, the plagiotropic stem, and the pulvinus, although in the first of these it is transient, lasting only during the action of stimulus. In all these cases alike, strong unilateral stimulus, acting on the less excitable proximal or upper surface, becomes internally diffused, and causes movement away from stimulus, or negative heliotropic response, in a direction which is perpendicular to the plane of separation of the two anisotropic halves. Thus there is no difference between the negative heliotropic responses of a radial and a pulvinated organ.

The distinction between the two cases of the permanent and temporary differentiation of the organ has been illustrated by Sachs by a reference to the induction of polarity in steel and in soft iron respectively. According to this analogy, *Marchantia* behaves to intense light like steel to a magnet,

retaining permanently the induced polarity. *Tropæolum majus*, on the other hand, behaves like soft iron, assuming a definite but temporary polarity, which disappears when the influence of light, like that of the magnet, is withdrawn. This illustration, however, though vivid, is likely to be misleading, for it suggests that, under strong stimulus, the normal properties of the organ pass into a polar or opposite condition. But there is no such change. Light merely induces a difference of excitability in the two sides. That there is no reversal of heliotropic sensibility is shown by the fact that either side, when excited by moderate intensity of stimulus, gives positive response. The necessary condition for the exhibition of negative heliotropic response is not only the differential excitability of the two sides of the organ, but also the internal diffusion of stimulus.

Owing, however, to the permanence of this differentiation in a pulvinate organ, there will be certain conditions under which the action of light will appear to be non-directive, for it is the diffuse stimulus, however produced, that brings about the responsive concavity of the more excitable lower half of the pulvinus, and this internal diffusion will take place just the same, whatever be the flank of the organ on which the strong external stimulus may have been applied. In the case of the radial organ, on the other hand, the differentiation between the less excitable proximal and more excitable distal is not fixed, but changes according to the side acted upon at the time by light.

The different responsive movements induced by light—positive, negative, dia-heliotropic, and para-heliotropic—have hitherto been ascribed, as I have already had occasion to point out, to as many specific sensibilities possessed by the plant. They have now, however, been demonstrated to be but so many examples of the general law that plant-organs respond to stimulus, by the induced concavity of the relatively more excited.

There is thus no fundamental discontinuity between the responses of radial and of dorsi-ventral organs, or between

positive heliotropic and negative heliotropic response. This will be seen still more clearly in the following statement, applying to the two extreme cases of radial and of dorsi-ventral organs, the plagiotropic constituting an intermediate link between the two.

General view of responsive curvatures induced in different organs by unilateral application of light

1. **Radial organs :** (a) *Positive response* : stimulus localised, the proximal side more excited and concave ; e.g. *Sinapis* under moderate unilateral light (p. 609).

(b) *Intermediate or neutral response* : stimulus internally diffused, causing equal excitation of proximal and distal sides ; the organ takes up a neutral (so-called dia-heliotropic) position, at right angles to light ; e.g. *Sinapis* under moderately strong unilateral light (p. 609) ; certain tendrils apparently insensitive.

(c) *Negative response* : strong stimulus internally diffused, which also induces anisotropy, the distal being then the more excitable ; concavity of the more excited distal ; e.g. seedling of *Sinapis*, and tendril of *Vitis* under strong unilateral sunlight (pp. 609, 611).

2. **Dorsi-ventral organs :** (a) *Positive response* : stimulus localised by relative non-conductivity of organ : the more excited proximal side concave ; e.g. positive movement of terminal leaflet of *Desmodium* ; the diurnal sleep movements of *Robinia*, *Erythrina indica*, and *Clitoria ternatea* (p. 629).

(b) *Intermediate or neutral response* : stimulus internally diffused ; upper and lower halves equally excited ; e.g. terminal leaflet of *Desmodium*, under several hours of vertically acting sunlight (p. 604).

(c) *Negative response* : strong stimulus acting from above on highly conducting organ, of which lower half is considerably more excitable ; concavity of the more excitable lower half ; e.g. fall of *Mimosa* leaf under strong illumination from above ; diurnal sleep movements of *Oxalis*, *Biophytum*, and *Averrhoa*.

SUMMARY

The responsive action of growing organs being not essentially different from that of pulvinated organs, a similar explanation must be applicable to the two classes of phenomena.

Owing to long-continued unilateral excitation by light, the upper side of a plagiotropic stem is rendered the relatively less excitable. Hence such organs may be regarded as equivalent to diffuse pulvinoids, of which the upper side is the less excitable.

In both these cases, of pulvini and diffuse pulvinoids, the local application of moderate stimulus on either side induces normal positive response.

But with long-continued application of strong stimulus two types of response may be obtained, according as the organ is characterised by a feeble or high power of transverse conductivity. In the former of these cases the stimulus will remain localised, and the response will be positive. In the second, the stimulus will become internally diffused, and if the lower side be the more excitable, stimulation of the upper will give rise to the concavity of the lower, constituting negative response.

As examples of the first of these classes may be mentioned the diurnal sleep movements of *Robinia*, *Erythrina indica*, and *Clitoria ternatea*, in which vertical illumination induces upward folding of the leaflets.

As representing the second class, we have both plagiotropic and pulvinated organs.*

The plagiotropic stems of *Mimosa*, *Ipomæa*, and *Cucurbita* exhibit increasing concavity of the lower side with the duration of the day's illumination.

A periodic downward movement is thus induced in them, which reaches its maximum at the end of the day. The reverse movement, of gradual erection, occurs during the night.

In pulvinated organs, negative heliotropic response, with

downward folding of the leaflets, is exhibited in the diurnal sleep movements of *Oxalis* and *Biophytum*.

In *Mimosa* the application of moderate intensity of light from above induces upward or positive heliotropic movement. Strong and long-continued application of light on the same upper surface, however, owing to the internal diffusion of excitation, induces concavity of the lower and more excitable side, or negative heliotropic movement. Both these responses may be regarded as cases of the directive action of light; but if the organ be excited by stimulus which is externally diffuse, the responsive movement is still downwards. The directive action of light has thus passed into non-directive.

CHAPTER XLVI

ON DIA-HELIOTROPISM AND DIA-GEOTROPISM

Difficulty of distinguishing between effect of light and other reactions—Theories of Frank and De Vries—Subsidiary factors : (1) Epinasty and hyponasty ; (2) Effect of gravity ; (3) Effect of suctional activity and of turgescence ; (4) Modification of effect by characteristic limits of flexibility—Discrimination of the part played by heliotropism in the movement of the leaf—Proof of absence of any specific dia-heliotropic tendency in leaves—The lamina not the perceptive organ—Principal types of the response of leaves to stimulus of light—Positive type of response : mango leaf—Negative type of response : leaf of *Artocarpus*.

WE shall now take up the question of the effects of illumination on ordinary leaves, which are generally supposed, on account of some special dia-heliotropic sensibility, to have the habit of placing themselves at right angles to incident light. We have seen in the last chapter that the movement of anisotropic organs under heliotropic stimulation is not the result of any specific sensitiveness, but constitutes a simple instance of the response of plant-organs to all forms of stimulus, the response being appropriately modified in this particular case by the anatomical and physiological peculiarities of the responding organ. We have been able to demonstrate the continuity of this responsive phenomenon by analysing it in two extreme cases of the anisotropic differentiation, those namely of the plagiotropic stem, in which we see one of its earlier phases, and of dorsi-ventral pulvinated organs, in which it attains its highest development. In the movements of ordinary leaves we have what is merely an intermediate stage between these, hence any explanation which would elucidate their action must be one which is applicable to both the extremes.

Difficulty of distinguishing between effect of light and other reactions.—In the case of the response of pulvinated organs, we had the advantage, owing to their great motility, of being able to refer each particular responsive movement to the immediate stimulating action of incident light. In ordinary leaves, however, the movements being very sluggish, it takes so long a time for any given responsive action to attain the requisite magnitude for ordinary observation, that other factors of variation intervene, and it becomes difficult to know how much of the resultant response is due to heliotropic stimulus as such. It is this great difficulty of disentangling the response due to light, which is the proper subject of the inquiry, from numerous other subsidiary factors that has led to the existing divergence of views among observers.

In the course of the present chapter, therefore, I shall shortly enumerate those various agencies which are subsidiarily instrumental in bringing about the ultimate position assumed by the leaf. I shall then describe a method by which heliotropic action proper can be discriminated with certainty from other influences. The relation between the fundamental action in response to light, which has already been demonstrated, and the heliotropic response of the leaves will thus be made apparent. But before entering upon these questions I shall briefly allude to the principal existing theories on this subject.

Theory of Frank.—There are at present two main types of opinion with regard to the question of the effect of light on leaves. Frank and his school account for that action of leaves by which they place themselves with their flat surfaces perpendicular to the direction of incidence of the rays of light, or of the action of gravity, by assuming that dorsi-ventral organs possess a peculiar property of sensitiveness to the directive action of light and gravity. This they designate as Transverse or Dia-heliotropism, and Transverse or Dia-geotropism. It is supposed that the habit has been acquired for the advantage of the plant, inasmuch as the leaves, by placing themselves

T T

in this particular position, are enabled to absorb the largest amount of sunlight. Such arguments, however, do not throw any light on the mechanism by which the movement is brought about. It is even somewhat difficult to understand how this generalisation, that leaves place themselves at right angles to light, has come to be accepted as a universal fact; for it is only necessary to make a visit to the open forest in order to see that, so far from this being the case, many leaves place themselves vertically upwards, others downwards, and the rest in all possible intermediate angles between the two. All that can be claimed on behalf of the dia-heliotropic position is that no deviation from it is greater than *plus* or *minus* 90°.

Theory of De Vries.—De Vries, however, is in disagreement with this theory. He establishes the importance of the unequal rates of growth in the upper and lower halves of the leaves—*i.e.* epinasty or hyponasty—as a factor in bringing about their ultimate attitude. He next assumes, in accordance with the generally accepted view, the existence of two opposite responsive reactions, positive and negative, in regard to light and gravity. He then proceeds to show that there can be no necessity for the further assumption of a third or dia-heliotropic tendency in the leaves, since epinasty and hyponasty, their different combinations with either of the opposite actions of positive and negative heliotropism and geotropism, and considerations of the weight and balance of parts, are all factors which take a share in determining the position ultimately to be assumed by the dorsi-ventral organ with regard to light.

I shall now attempt to demonstrate the fact that the responses of ordinary leaves are in every way similar to those of the pulvinate, the mechanics of whose movements have already been fully described. It will further be shown how and under what circumstances the normal positive passes into negative response, through certain intermediate phases.

Subsidiary factors.—But before undertaking either of these inquiries, it will be well to enumerate briefly the

subsidiary factors which combine with the heliotropic action proper in determining the final position of the leaf.

1. *Epinasty and hyponasty*.—These unequal growths of one side or the other, De Vries believed to be brought about by some spontaneous unknown cause in the plant itself. Detmer, however, came to the conclusion that, as regarded epinasty, it was not spontaneous, but induced by the action of light. This conclusion was based on the observations (1) that cotyledons of *Cucurbita* remained closed up, in continuous darkness, but opened out when subjected to light; and (2) that the primordial leaves of *Phaseolus*, kept in darkness, remained folded, and only opened out on illumination. The investigations of Vines, however, though he supports the contention of Detmer with regard to *Phaseolus*, have led him to a different view in the case of *Cucurbita*, where he finds the epinastic movement to be induced even in the absence of light. He has therefore come to the conclusion that the phenomena of epinasty and hyponasty are spontaneous, and not directly due to the action of illumination.

These differences of opinion, however, have arisen from the obscurity in which autonomous or spontaneous movement has been involved, and they may be expected to disappear when its true nature is clearly perceived. These alternate movements of growth are in fact only another example of multiple or autonomous response, the difference between them and those other forms with which we are already acquainted lying in the greater slowness of their period, and in the relative fewness of the pulsations that can be exhibited. In the case of autonomous pulsation or circumnutation of stems, since the growth on which they depend is indefinitely prolonged, we have an indefinite continuance of these pulsations. In the case of leaves, however, the organ usually completes only half its swing, whether epinastic or hyponastic, and by that time further pulsation is arrested, owing to the cessation of growth; yet in some cases there is more than a semi-pulsation, as where hyponastic movement is followed

T T 2

by epinastic. It has already been shown that autonomous response in general can take place only when the internal energy or the sum total of the latent stimulating factors is above par. This is equally true of the autonomous response of growth itself. In the case of autonomous epi- or hypnastic pulsations, therefore, a certain amount of internal energy is essential for their initiation. This is in some cases supplied by other forms of stimulus, but there may be others in which light is the critical factor. In order, then, to study the directive action of light on dorsi-ventral organs under normal tonic conditions, we must be able to determine the characteristic influence which will be exerted by the stimulus of incident light in modification of the already existing movement of the organ. This inquiry is therefore exactly parallel to our previous study of the action of light in modifying the existing growth-movements of radial organs. In that case the *variations* induced in the ordinary rate of movement afforded us a measure of the effect of the stimulus of light. In the case of dorsi-ventral organs such as leaves, similarly, the effect of light can be correctly inferred only by observing the *variations* which it induces in their existing movements. The manner in which this is done will be described presently.

2. *Effect of gravity.*—In long-continued experiments on the curvatures induced by light, the observed movement is also modified in part by the influence of geotropism. This geotropic action in leaves is by some investigators believed to be of two types, negative and positive. Others, again, regard it as dia-geotropic. I shall, however, adduce considerations which will show that the upper and lower halves of dorsi-ventral organs exhibit differential excitability to geotropic as to other forms of stimulus. In order to neutralise the geotropic action, and thus study the heliotropic effect alone, Francis Darwin mounted the plant on a rotating klinostat. It is true that in a strictly radial organ the geotropic effect is successfully neutralised by rotation on the klinostat, since in this case the geotropic sensitiveness of the

different flanks is the same ; but this, as will appear from certain experiments to be described later, cannot be said of dorsi-ventral organs, for in these geotropic sensitiveness is different in the upper and lower halves. In my own experiments on the action of light, however, I shall be able to give results which are but little affected by geotropism.

3. *Effect of suctional activity and of turgescence.*—There are two other factors not hitherto taken into account which exert considerable influence in determining the attitude finally assumed by the leaf. These are the general condition of turgescence of the plant, and the limits of flexibility which characterise the particular responding organ. The first of these is, as we have seen, dependent on the suctional activity. Now, the mechanical response of a plant-organ is the result, as we already know, of the expulsion of water from the excited tissue ; but if the tissue be over-turgid expulsion of water is opposed, and the responsive movement is thereby reduced or abolished, as we have seen in the case of *Mimosa* in a condition of excessive turgor. The same phenomenon I have again seen manifested, in a remarkable manner, in the difference of the movements made by the leaves in response to light according as they were normally- or super- turgid. Thus, in a small plant of *Artocarpus*, grown in a pot, and in the autumn season, when the suctional activity was not great, the leaves responded to light by making a progressive angle with the vertical, so that, under the long-continued action of light, they first reached the horizontal position and then fell many degrees below it ; but in the rainy season, when they held themselves abruptly vertical in consequence of excessive turgor, the action of light produced little or no responsive movement. In the autumn season, again, the limited system of roots and rootlets possessed by this plant, when grown in a pot, allows it only a moderate degree of turgescence, and in this condition it readily responds to light ; but a large tree of the same species, growing in the open and possessed of a highly ramified and extensive root-system, will during the same

season, its turgescence being great, maintain its leaves in a vertical position, but little affected by the action of light. From this it will also become clear that any influence, such as long maintenance under darkness, which modifies the suctional activity, is liable to render the response of the plant abnormal.

4. *Modification of effect by characteristic limits of flexibility.*—I shall here deal with another important factor in the determination of the final position assumed by the leaf—that is to say, with the anatomical peculiarities which determine the limits of flexibility. Let us take the petiole bearing the terminal leaflet of a leaf of *Desmodium*. We now suppose this leaflet to be outspread, in such a position that its midrib is in a continuous straight line with the petiole. This upper line we shall know as the *dorsal line*. It consists of two parts or components, the laminal and the petiolar. In this particular position they form a straight line; but the movement of the leaflet takes place with the point of junction as the hinge. We shall then distinguish that particular position of the dorsal line in which the laminal and petiolar halves are continuous and straight as neutral, and angular movements above or below will be measured accordingly. In the case of *Desmodium*, when the terminal leaflet has reached the neutral position, it cannot, owing to the anatomical peculiarity of the joint, be bent further upwards; but it can be bent in the opposite direction, that is downwards, until the leaflet lies along the under side of the petiole, the curvature being then through 180° . Thus the limits of flexibility of this leaflet may be expressed by the formula $\frac{0^\circ}{180^\circ}$: that is to say, its flexibility above the neutral position is 0° , and below, 180° . Now, the petiole itself, in the case of *Desmodium*, for example, may, and does, occupy many different positions with regard to the stem. Let us suppose it at a given moment to subtend an acute angle, being thus more or less vertical, and suppose the terminal leaflet to be horizontal. If light now acts from

above, the leaflet will move continuously upwards till the lamina has reached the neutral position—that is to say, till the midrib constitutes a straight prolongation of the petiole ; but if light act on the leaflet from below, it will bend downwards (fig. 259, *a*). If the petiole, however, at the beginning of the observation be horizontal instead of vertical, and the lamina be in the neutral position, then vertical light cannot, owing to the anatomical peculiarities of the pulvinar joint, carry the leaflet further above the dorsal line (fig. 259, *b*). Or we may

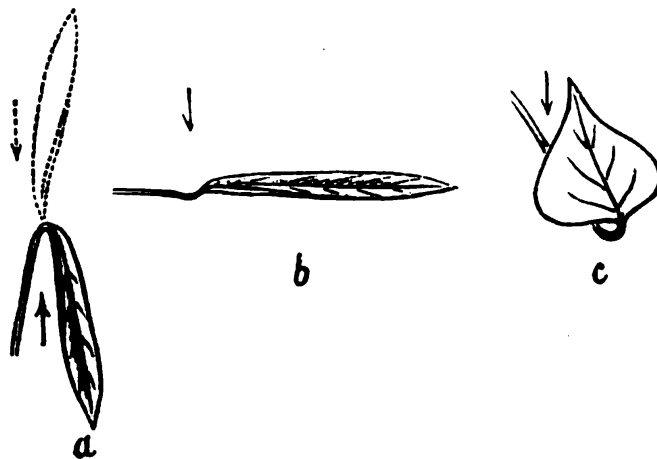

FIG. 259. Different Limits of Flexibility

Vertical light on terminal leaflet of *Desmodium* causes (*a*) up movement till the dorsal line is a continuous straight line; light applied below causes movement downwards below this neutral line through 180° . In *b* is shown neutral position, after reaching which there is no further movement upwards. In *c* is shown movement of terminal leaflet of *Erythrina indica* upwards, under vertical illumination, through 180° above the neutral line.

again take as an example the terminal leaflet of *Erythrina indica* (fig. 259, *c*). The limit of flexibility is in this case represented by an angle of almost 180° above the neutral, whereas downwards its limit is about 90° . The formula is thus $\frac{180^\circ}{90^\circ}$. Now, when this leaflet is acted upon by light from above, it may become almost doubled upon the petiole upwards, just as we found the terminal leaflet of *Desmodium* to be almost doubled downwards. Hence we see that though the heliotropic effect of light is always the same, yet

the position of the leaflet in space--that is to say, its relation to the vertical line—is largely modified not only by the limits which the anatomical structure of the laminal pulvinus or pulvinoid imposes upon its flexibility, but also by the angle which the petiole makes with the stem; for there is, generally speaking, a second pulvinus or pulvinoid at the junction of the petiole and the stem, and this petiolar pulvinus is, in its turn, more or less sensitive to stimulation (p. 59). We have thus obtained some idea of the anatomical elements, regarding the petiole and its joints, which enter into the complex question of the final position assumed by the leaf in space.

Discrimination of the part played by heliotropism in the movement of the leaf.—In studying the heliotropic effect we are concerned only with the action of light itself, and not with the resultant effect, due to various co-operating factors. When the action of each of these is definitely understood, it becomes a simple problem to understand the effects due to their combination. The difficulty of this investigation has hitherto lain, as already said, in the fact that, owing to the generally sluggish nature of responsive movements in ordinary leaves, a long time must be allowed to elapse before they become measurable, and during this long period other factors may become operative in unknown ways. The effect of light, however, can easily be discriminated by the use of the Optic Lever for record, for this allows us any degree of magnification which may be desired. Thus the natural curve gives us the resultant effect of all the pre-existing factors under normal tonic conditions, and its subsequent variations under the incidence of light at once exhibits the distinctive action of that stimulus. On the withdrawal of light, again, the recovery from the induced variation affords an additional corroboration of the inference that the variation itself had been due to the action of light. In consequence, moreover, of the delicacy of this means of continuous record, the characteristic effect can be detected in the course of a few minutes, thus eliminating the unknown

changes which are liable to occur during the lapse of long intervals of time. The action of light is, generally speaking, so predominant over that of the subsidiary factors, that a high magnification of record is not necessary. Under these circumstances, that is to say under low magnification, the record before the application of light is practically a horizontal line. Under vertical illumination of the upper side of the leaf, then, deviation above this horizontal represents a positive heliotropic movement, while deflection in the opposite direction signifies the negative.

But before I proceed to give details of my experiments, I shall adduce facts which will show that there is no inherent tendency in the leaves to move in such a manner as to place themselves at right angles to the light.

Proof of absence of any specific dia-heliotropic tendency in leaves.—A *Desmodium* plant was taken, and the petiole fixed horizontally,

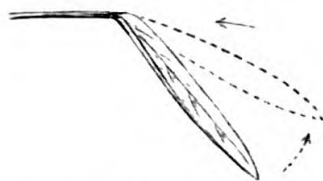

FIG. 260. Movement of Terminal Leaflet of *Desmodium* placing itself Parallel to Incident Horizontal Light

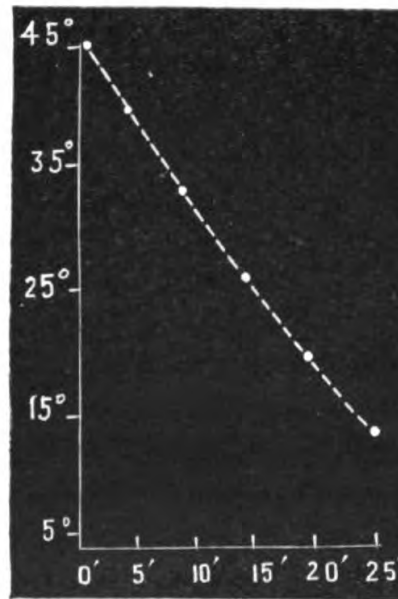

FIG. 261. Curve showing Time-relations of the Responsive Angular Movement of Terminal Leaflet of *Desmodium* under Light, as represented in the last figure

The original angle of 45° between the surface of the leaflet and the direction of incident light was reduced to 13° in the course of 25 minutes.

the terminal leaflet being at an angle of 45° with the horizon. Sunlight was then made to strike it horizontally (fig. 260). It now the leaflet had a dia-heliotropic tendency, it is clear that its movement would be such as to increase its angle with the horizon to 90°, thus bringing the light to strike it at right

angles. Movement in the other direction—that is to say, towards the decrease of the angle—would, on the other hand, indicate that the effect of light was to induce the normal positive heliotropic response. From the record (fig. 261) it will be seen that the latter was the case—that is to say, the leaflet moved continuously, tending to become parallel to the light, having in the course of twenty-five minutes moved from its position at an angle of 45° to one at 13° to the horizon—that is to say, at an average rate of angular movement of about 1.3° per minute.

The lamina not the perceptive organ.—If, again, the object of the so-called dia-heliotropic movement had been the absorption by the upper surface of the lamina of the largest possible amount of light, it would have been necessary for the lamina to be the perceptive organ, determining its movement according to the direction of stimulus; but that this is not the case may be demonstrated by subjecting the lamina alone to the action of light, and covering the pulvinus with a small opaque shield of black paper. On doing so all movement is found to be arrested. If now, on the other hand, the leaflet be covered with opaque paper, and the pulvinus be left exposed, the usual heliotropic movement is found to take place. This conclusively proves that, as regards the response of the leaf to light, the lamina is not the perceptive organ, and therefore that a supposed advantage to itself cannot be the important factor in determining its movement. That the lamina is not the perceptive organ has indeed been shown already in the case of ordinary leaves, when subjected to forms of stimulus other than light (p. 60). We saw this, for example, in the case of a leaf of *Artocarpus* when subjected to electrical and thermal stimulation. It was in that case shown that since the lamina consisted of a mass of non-conducting parenchymatous tissue, local excitation might be caused by the incidence of stimulus, but could not be effectively transmitted to the distant pulvinus or pulvinoid by which the movement of the leaf was brought about. The only case in which such transmission is possible to some

extent in leaves is in the parallel-veined leaves of monocotyledons. This fact, that the lamina is not in general the perceptive organ with regard to stimulus, say of light, is still further demonstrated in the following experiment, performed on the leaflet of *Erythrina indica*. Sunlight was first applied locally to the lamina of this leaflet by means of a suitably inclined mirror, at the point in the record which is marked \times (fig. 262). It will be noticed that during ten minutes of such application not the slightest responsive movement was induced. Keeping everything else the same, the light was

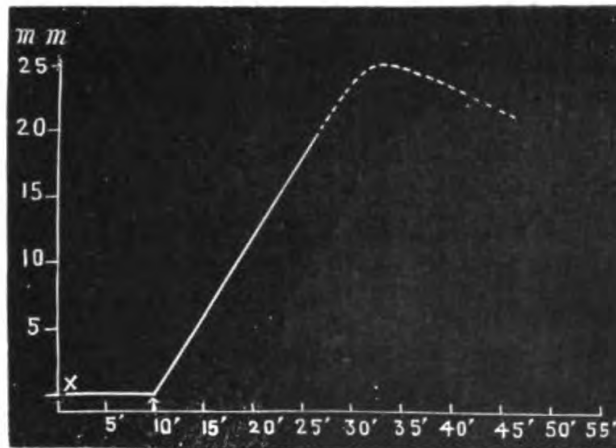

FIG. 262. Record showing that Lamina is not the Perceptive Organ

Light applied vertically at \times on lamina of *Erythrina indica*, and continued for ten minutes, produces no response; but when applied on the pulvinus at the arrow (\uparrow) there is immediate positive response. Dotted line shows positive after-effect and recovery on cessation of light.

now shifted by a movement of the mirror, and thrown directly on the pulvinus, at the point in the record which is marked with an arrow (\uparrow). It will be observed that the leaf began to respond immediately by a movement towards the light, and in the course of seventeen minutes' exposure its tip moved through a distance of 20 mm. or at an average rate of a little over 1 mm. per minute. On the withdrawal of light the movement persisted, owing to the positive after-effect, for a period of seven minutes, after which recovery began. The marked difference between the quiescent con-

dition of the leaflet during the ten minutes' exposure of the lamina to the action of light, and its energetic movement immediately on the application of light to the pulvinus, shows once more, in a striking manner, that it is the latter organ and not the lamina whose perception of light is effective in initiating the responsive action.

Principal types of the response of leaves to stimulus of light.—I shall now proceed to show that the directive effect of light on leaves is very definite. In studying the response of anisotropic organs—that is to say, plagiotropic shoots and dorsi-ventral pulvinated leaves—we have seen that there are two extreme types of response, of which the first is exhibited by organs possessing feeble transverse conductivity, and the second by those in which the transverse conductivity is great, and the lower side the more excitable. In the first of these types, light acting on the organ from above gives rise to a positive heliotropic response. In the latter, long-continued application of strong light from above gives rise to internal diffusion of stimulus, causing concavity of the more excitable lower half, with the result of negative heliotropic response. Intermediate between these we have seen that there are cases of the equal excitation of the upper and lower halves of the organ, bringing about the so-called dia-heliotropic position. As examples of the two extreme types—within which lie the responses of all ordinary leaves—I shall here give records of the movements of leaves of Mango (*Mangifera indica*) and of *Artocarpus*.

Positive type of response: Mango.—The leaves of this plant when young are bent abruptly downwards by the sharp curvature of the short petiole. In the course of a week or so, however, they rise, and gradually attain a position at or above the horizontal, a process in which the action of light is an important agent. This will be seen from the following record of the movement of a Mango leaf when acted upon by sunlight from above (fig. 263). The record before the application of light was practically horizontal, showing that there was little natural movement; but the

application of light induced an energetic movement upwards—that is to say, a positive heliotropic response, the tip of the leaf moving through a distance of 35 mm in the course of sixty-five minutes—that is to say, at an average rate of .53 mm. per minute. On the cessation of light there was a slow recovery, which was found to be only partial.

Negative type of response: Artocarpus.

—As an example of negative response by the internal diffusion of stimulus, due to the high transverse conductivity of the tissue, and the greater excitability of the lower half of the pulvinoid, I give here two records, from

leaves of different ages, borne on the same plant, under the action of strong sunlight from above (fig. 264). The upper of these two records was taken from a young leaf, which was second in order from the top of the shoot, and the lower from the fourth. It is generally found that motile sensitiveness is at its greatest in leaves which are neither too young nor too old. In the present experiment the upper of the two leaves, which was very young, gave a negative heliotropic response, the tip moving through 15 mm. in the course of eighty minutes, or at an average rate of almost .2 mm. per minute. In the case of the lower leaf the rate of the responsive movement was more rapid, being on an average .5 mm. per minute.

As regards leaves, then, their responsive movements under light have been shown to be very definite, and simply

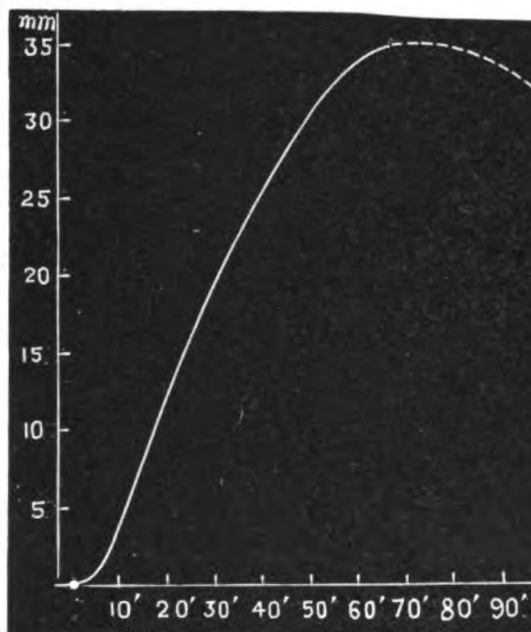

FIG. 263. Positive Heliotropic Movement of Leaf of *Mangifera indica* under Sunlight acting from Above

Dotted line shows recovery on cessation of light.

determined by the fact that it is always the more excited side of the motile organ that undergoes contraction and concavity. That various types of this effect arise is due only to the unequal excitabilities of the two halves, and to the fact

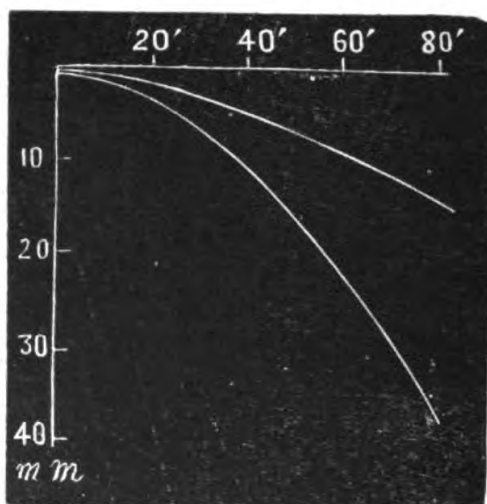

FIG. 264. Negative Heliotropic Response of Leaves of *Artocarpus* under Sunlight acting from Above

The upper record exhibits the response of a very young leaf, second in order from the top of the shoot. The lower record shows that of an older leaf, fourth in order on the same shoot.

stimulus of gravity ; (3) the turgescence condition of the plant, as determined by its suctional activity ; and (4) the limits of flexibility of the organ, as determined by its anatomical peculiarities. It is out of the innumerable possible combinations of these factors that the variety of attitudes ultimately assumed by the leaves directly arises.

With regard to the nature of geotropic action on leaves, it will be shown in the next chapter that here also, as in the case of dia-heliotropism, the assumption of a dia-geotropic property is unnecessary ; for the observed effects are explained by the fact, which I shall demonstrate, that a dorsiventral organ possesses differential geotropic sensibility.

that the stimulus remains in some cases localised, while in others, owing to the better transverse conductivity of the tissue, it becomes internally diffused. The position ultimately taken up by the leaves is thus determined primarily by the action of light, and secondarily by that of various subsidiary factors, which are : (1) the natural movement of the organ, due to hyponasty or epinasty ; (2) the differential excitability of the two halves of the dorsiventral organ under the

SUMMARY

The position ultimately assumed by a leaf is determined by heliotropic action and other subsidiary factors.

These subsidiary factors are : (1) the natural movement of the organ, due to epinasty or hyponasty ; (2) the differential excitability to gravitational stimulus of the two halves of the organ ; (3) the effect of suctional activity and of turgescence ; and (4) the modification of effect by the characteristic limits of flexibility of the organ.

As regards the action of light, the lamina is not the perceptive organ, and there is no specific dia-heliotropic sensitiveness possessed by the leaves.

The sensibility of the pulvinoid of a leaf is essentially similar to that of a pulvinus. There are two main types of response given by pulvinoids : (1) that exhibited when the conductivity of the organ is feeble, and vertical light induces movement upwards, or *positive response* ; and (2) that exhibited when conductivity is great, and the lower half is the more excitable, inducing movement downwards, or *negative response*.

The various attitudes assumed by the leaves are the joint effects of these responsive actions, and their modification by epinasty or hyponasty, the differential action of gravity, the turgescence condition of the plant, and the limits of flexibility of the pulvinus or pulvinoid.

CHAPTER XLVII

TORSIONAL RESPONSE TO HELIOTROPIC AND GEOTROPIC STIMULUS: AUTONOMOUS TORSION AND ITS VARIATIONS

Torsional effect—Method of recording torsional response—Torsional response under the lateral action of light—Torsional response to other forms of lateral stimulation—Torsional response of compound strip of ebonite and stretched india-rubber—Modification of torsional response by artificial variation of the relative excitabilities of the two halves—Laws of torsional response—Demonstration of differential geotropic excitation in a dorsi-ventral organ—Torsional response to lateral geotropic stimulation—Modification of torsional geotropic response by artificial variation of differential excitability—Autonomous torsion: effect of temperature—Effect of light—Effect of electrical current—Effect of gravity—The twining of stems.

IT has been shown in the course of the last chapter that the movement of the leaf in response to light constitutes a simple instance of that general reaction of plant tissues to stimulus with which we have now become familiar, and that no specific sensibility requires to be postulated in order to account for it.

Torsional effect.—There is one effect, however, which has hitherto appeared to be inexplicable, except on the supposition that some such specific sensibility had actually been acquired by the leaf for the definite purpose of subserving the advantage of the plant by placing the upper surface of the lamina at right angles to incident light. A leaf when struck laterally by light undergoes a torsion, which carries the upper surface of the lamina into such a position that it faces the light. No result could seem at first sight more conclusively to support the theory of dia-heliotropic sensibility. Before going further into this question, I shall give records of the actual effect observed. In fig. 265 is shown a curve which exhibits the increasing torsion induced

by lateral application of sunlight in the terminal leaflet of *Desmodium*. A light index was attached transversely to the lamina, by means of which, and with the help of a protractor, the gradually increasing torsion was measured at definite intervals of time. It will be seen from the curve

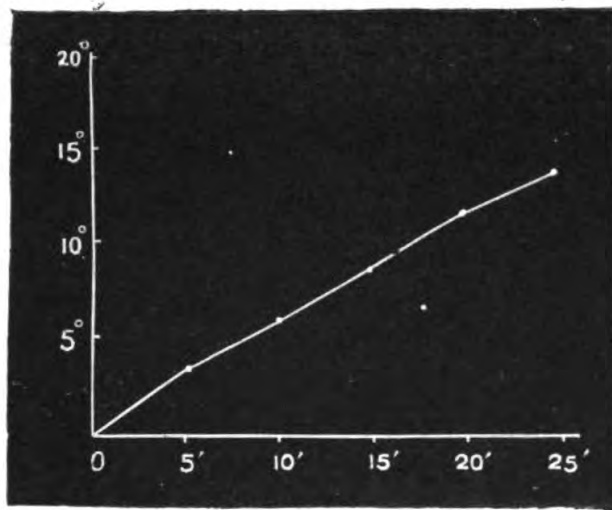

FIG. 265. Torsional Response of Terminal Leaflet of *Desmodium* under the Action of Lateral Sunlight

Abscissa represents time in minutes, and ordinate angular movement in degrees.

thus obtained, of which the abscissa represents time, and the ordinate the induced angular torsion, that in this case, within twenty-five minutes, a torsion of 14° had been induced.

Method of recording torsional response.—For the purpose of certain investigations, presently to be described, in connection with this torsion, it became necessary to devise special experimental arrangements by which a continuous record of the rate of torsion and its variations could be obtained. The mode in which this was accomplished will be understood from the illustration in fig. 266. A mirror, carried on a light spring-clip made of aluminium, is slipped over and attached to the petiole, at a short distance from the pulvinus or pulvinoid, which is the seat of the torsional movement. As the object is to record only the torsion, the

U U

vertical up and down movement, if there be any, is prevented by a lateral support, which has at its end a smooth bent rod of glass, in the concavity of which the free petiole rests. If there be any responsive torsional movement, a spot of light reflected from the mirror will now undergo a vertical deflection. This is, for convenience of the record, converted into lateral by reflection from a second mirror suitably inclined. The response record is then taken in the usual manner on

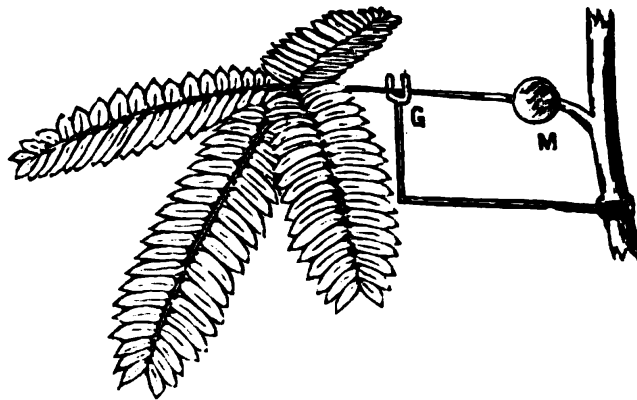

FIG. 266. Torsion-recorder

M, mirror slipped over petiole by light aluminium clip behind; G, bent glass piece supporting petiole to prevent vertical movement.

a revolving drum. The absolute value of the angular movement shown in the record can be determined from a knowledge of the distance from the mirror of the recording drum.

Torsional response under the lateral action of light.—The pulvinus of the leaf, say of *Mimosa*, is now stimulated by throwing upon it a horizontal beam of light, which strikes it laterally. By the word *lateral* is here meant either the right or left flank of the pulvinus or pulvinoid, consisting of part of the upper and part of the lower anisotropic halves. This causes a responsive torsion, by which the petiole is rotated, the tendency being for the upper, or less excitable, half to face the stimulating agent. The up curve, then, in this and the following records will represent a torsional movement by which the less excitable upper side is made to

face the source of stimulus. In the present case (fig. 267) we see that the responsive torsion took place during the application of light, and that on the cessation of stimulus there was a positive after-effect, followed by recovery. If light were applied laterally on the opposite flank, the torsion would be found to take place in the opposite direction, the law which determines such movement being, as said before, that the less excitable is always turned towards the stimulus. In connection with this, we have to notice, in the first place, that the responsive torsion takes place not when the lamina, but when the pulvinus, is acted on laterally by light; and, secondly, the particular torsion in question results from the differential action of stimulus, by its lateral application to a complex organ, the lower half of which is the more excitable.

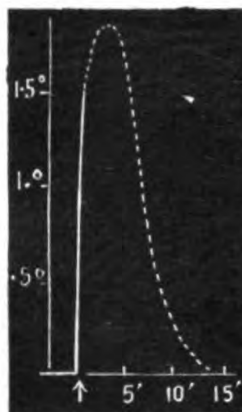

FIG. 267. Torsional Response of Leaf of *Mimosa* when Laterally Stimulated by Sunlight

The ordinate gives the absolute angular movement in degrees. The dotted line shows positive after-effect and recovery on stoppage of light.

Torsional response to other forms of lateral stimulation.—The supposition that this torsional response is due to a specific sensibility to light, evolved for the advantage of the plant, will be found entirely untenable if it can be shown that the same movement is manifested under the same conditions in response to other forms of stimulus. Thus, on bringing a heated wire near that side which was previously excited by light, I obtained exactly the same torsional response of the same sign. Still more interesting is the excitation of the same lateral side by chemical stimulus, say a strong solution of common salt. In the record given (fig. 268) we see how similar in every way are this response and that evoked by light. The upward arrow (↑) indicates the application of chemical stimulus to the same flank as had previously been stimulated by light, of which the record is

U U 2

given in fig. 267. The downward arrow (\downarrow) indicates the application of the chemical solution to the opposite flank. It will be noticed that we have in consequence, in the dotted portion of the record, a reversal of the first torsional response.

Torsional response of compound strip of ebonite and stretched india-rubber.—Enough has already been said to demonstrate the fact that the torsion induced in leaves by the lateral application of light is not due to any specific sensibility to light as such. I shall next therefore proceed to show that the same torsion is the mechanical result of the differential

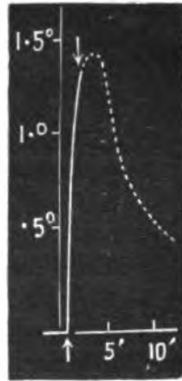

FIG. 268. Torsional Response of Leaf of *Mimosa* to Lateral Chemical Stimulus

Upward arrow (\uparrow) indicates moment of application of stimulus to one flank ; (\downarrow) indicates application of stimulus to opposite flank, with effect of reversing torsional movement.



FIG. 269. Torsional Response of Complex Strip of Ebonite and India-rubber under Lateral Action of Strong Radiation

contraction of a complex organ, which is fixed at one end, and subjected to lateral stimulation. I have in a former chapter described an artificial model of the pulvinus of *Mimosa*, which consisted of a compound strip, the upper half of which was ebonite, and the lower the more contractile stretched india-rubber. If such a strip be held securely at one end in a clamp, and if the lateral flank, consisting half of ebonite and half of india-rubber, be subjected to the strong action of light, records being taken in the usual manner, it will be found that a torsional response takes place which is in every respect similar to that of the pulvinus of a

leaf, the less contractile ebonite being turned so as to face the light (fig. 269).

Modification of torsional response by artificial variation of the relative excitabilities of the two halves.—

I find it necessary to go still further into this subject of torsional response, as by its means I have been enabled to solve a question of very great importance, that, namely, of the different excitabilities of the two halves of the anisotropic organ to geotropic stimulus. The fact that it is the differential character of the excitabilities of these two halves that brings about the torsion of a dorsi-ventral organ under lateral stimulation may be still further established in a very interesting manner by inducing artificial variation in the existing excitabilities. The torsion depends, as said before, on the difference of excitability as between the two. If, then, we could render the lower and more excitable half gradually less and less excitable, till its differential excitability had disappeared, the organ would thus have been rendered virtually radial. The torsional effect might then be expected to vanish, and a simple curvature towards stimulus to result, without torsion, as in the case of other radial organs. Let us next suppose the reduction of excitability to be carried still further, till the lower half of the pulvinus have been rendered less excitable than the upper. On the theory of torsional response which has just been advanced, it is the less excitable lower half which should now twist round to face the stimulating light. In other words, there would then be a reversal of the original torsion. Thus, as the excitability of the lower half becomes gradually reduced, the intensity of the normal positive torsional response by which the upper half was made to face the stimulus would be gradually first decreased to zero, and then reversed to negative, as the excitability of the lower became first equal to, and then less than, that of the upper half.

If, on the other hand, the excitability of the *upper* half be reduced, the existing differential excitability as between upper and lower would then be still further increased, and the intensity of the positive torsional response would be

enhanced. All these conclusions will be found exactly verified in the records given in fig. 270. In the first part of the left-hand figure we see the normal positive torsional response of *Mimosa* under the lateral action of light. The excitability of the lower half of the pulvinus was then

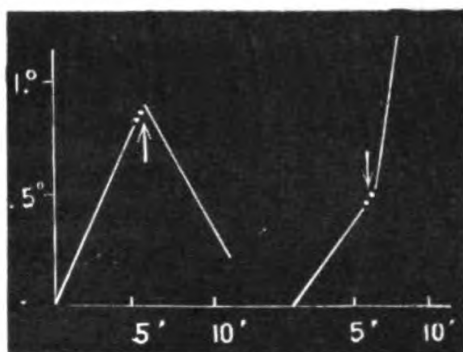

FIG. 270. Records showing Modification of Torsional Response under Induced Variations of Differential Excitabilities in Pulvinus of *Mimosa*

In left-hand figure the normal torsion is seen to be reversed by application of chloroform to the lower half (\uparrow), reversing the differential excitability of the organ. In the right-hand record the normal responsive torsion is enhanced by application of chloroform to the upper half (\downarrow), increasing the natural differential excitability of the organ.

reduced by the local application of chloroform, at the moment represented by the arrow from below (\uparrow). It will be seen that the response now undergoes reversal, owing to the fact that it is the upper side that is the relatively more excitable. In the figure to the right, again, is shown the effect on the torsional response of the leaf, of *increasing* the already existing difference as between the excitabilities of the two halves, when that of the upper is reduced by the local application of chloroform. It will

be seen that this application as marked by the arrow from above (\downarrow) caused an enhancement of torsional response, as seen in the greater steepness of the curve.

Laws of torsional response.—From these experiments we arrive at the following laws :

1. An anisotropic organ, when laterally excited, undergoes torsion, by which the less excitable side is made to face the stimulus.

2. Stimulus remaining constant, the intensity of torsional response increases with the differential excitability. But when the original difference is in any way reduced or reversed, the torsional response undergoes concomitant diminution or reversal.

3. **An organ which, under lateral stimulation, responds by torsion, is always physiologically anisotropic, and the side which is made to face the stimulus is the less excitable.**

Demonstration of differential geotropic excitation in a dorsi-ventral organ.—From this experimental demonstration, then, we have obtained a new means of discriminating the relative excitabilities of the two halves of an organ, since that side which is turned by the responsive movement to face the given stimulus is relatively the less excitable to it. It will be remembered that we found that the reason why certain dorsi-ventral organs showed a tendency to assume a horizontal position under the action of vertical light was not that they possessed dia-heliotropic sensibility, but was due to the differential excitability of the two halves under stimulus in general, including that of light. Again, in the case of the action of gravity, it is found that such organs exhibit a similar tendency to place themselves horizontally; and the assumption of a specific dia-geotropic sensibility is not necessary, if it can be shown that the upper and lower sides are unequally sensitive to this stimulus also. We may first take an ideally simple case. We have seen that in a radial apogeotropic stem, when laid horizontally, it is only the upper half that is effectively stimulated by geotropic action; and there was reason to believe that this was due to the fact that it was the inner tangential wall of the upper side—in contrast to the less excitable outer wall of the lower side—that was excited by the statolithic or other influence of weight (pp. 495, 503). If now, for any reason, the excitability of the upper half of the horizontally placed radial organ be abolished, the geotropic response of that effective half will disappear, and the organ will remain horizontal, as if unaffected by stimulus of gravity. This state of things we have already realised, when the excitability of the upper half was artificially diminished by the local application of cold, and geotropic response was seen to be arrested (p. 504). Now, a horizontally placed radial organ which has been rendered unequally excitable

in the two halves, by the reduction of excitability of the upper, is virtually a plagiotropic or dorsi-ventral organ, and we can thus see why a true plagiotropic organ, laid horizontally, has a tendency to remain in that position. It would remain in that position absolutely if the excitability of the outer tangential wall of the lower side were actually zero, and the general excitability of the upper half of the dorsi-ventral organ had also completely vanished; but if these two values were not both zero, various effects would occur, according to the relative differential excitabilities of the two halves.

I shall now describe the line of investigation by which it is possible to demonstrate the fact that the two halves of an anisotropic organ possess different excitabilities with regard to geotropic stimulus; but before entering upon this, it is necessary to obtain a clear idea of the direction of response, in relation to direction of the force which causes stimulation of gravity. In the case of an apogeotropic stem, laid horizontally, we have vertical lines of force striking the organ from above, and the curvature induced makes it turn upwards to meet, as it were, these lines of force. We have here an example which is analogous to the response of the organ to the rays of light, in which the responsive movement consists in a similar curvature upwards to meet them.

The fact that the upper and lower halves of an anisotropic organ are unequally excited by light has just been demonstrated by means of torsional response, where it was shown that lateral excitation induced a twisting movement by which *the less excitable was made to face the incident rays*. By a similar torsional response of the anisotropic organ we are able not only to demonstrate the unequal geotropic excitability of the upper and lower halves, but also, by noting which of the two is made to face the lines of gravitational force, to determine which it is that is the less excitable to this particular form of stimulus.

Torsional response to lateral geotropic stimulation.—
For this experiment I took a leaf of *Erythrina indica*, whose

pulvinus I find to be very sensitive to geotropic action. Under normal conditions the leaflets of this plant place themselves horizontally. I now took one of these, say the terminal, and adjusted the plant so that its lateral edge was vertical. The dorsal and ventral halves of its pulvinus were thus equally subjected to geotropic action. This experiment, it is to be noted, was carried out in a dark room, where the only stimulus acting was geotropic. It will be seen, from the first part of the left-hand record in fig. 271, that under geotropic stimulus a torsional response was here obtained, which was exactly similar to that given under the action of light in fig. 270. The angular movement was in this case at the rate of about 11° per minute, and it was the dorsal surface of the organ that was eventually turned upwards—that is to say, so as to face the lines of force of gravity. This experiment, then, conclusively demonstrates the fact that the two halves of the dorsi-ventral organ are unequally sensitive to geotropic stimulus, and that it is the upper which is the less sensitive.

Modification of torsional geotropic response by artificial variation of differential excitability.—The fact that the upper half is, under normal conditions, the less excitable to geotropic stimulus is capable of further and striking demonstration, by the tests of reversal, and acceleration of torsional response. I have already explained, as will be remembered, that if the existing difference of excitability were reversed, the direction of torsional response would also be reversed; and that if, on the contrary, the difference were by any means increased, the rate of torsional movement would be correspondingly accelerated. In the first part of fig. 271 is seen the natural torsional response of the terminal leaflet of *Erythrina indica*. The excitability of the lower half of the pulvinus was now abolished, by the local application of chloroform, at the point marked with an upward arrow, and the torsional response to geotropic stimulation was thus found to be reversed, from *plus* 11° to *minus* 05° per minute. Hence it was now the lower half of the pul-

vinus—artificially rendered the less excitable of the two—that was found turning upwards, to face the rays of incident force of gravity.

The converse of this experiment would consist in still further reducing the excitability of the upper half of the pulvinus, in which case the normal differential excitability of the two halves would be increased, and the geotropic response enhanced. The right-hand record in fig. 271 shows

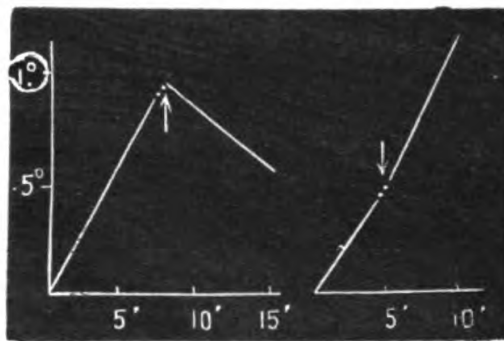

FIG. 271. Records showing Torsional Response to Geotropic Stimulus and Induced Modifications in Terminal Leaflet of *Erythrina indica*

In the figure to the left is seen the normal torsion under lateral geotropic action, and its reversal when the differential excitability of the organ is reversed by the application of chloroform to the lower half (↑). In the figure to the right is seen the enhancement of the torsional response when the natural differential excitability is increased by the application of chloroform to the upper half of the organ (↓).

of light is in every way paralleled by their differential excitability to the stimulus of gravity. The geotropic response of the organ, as a whole, is neither simple positive nor negative, but may be more fittingly described as *differential*. And as we saw with regard to photic stimulus that there was no need for the assumption of any specific dia-heliotropic sensibility in plagiotropic stems or in leaves—their movements being fully accounted for by the mechanical considerations arising out of their differential excitability to

that this is what actually occurs. The first part of the record displays the normal torsional response, and that which follows, after the local application of chloroform on the upper surface—indicated by the arrow from above—exhibits, by its increased steepness, the enhanced character of this response.

We have thus seen, by means of torsional response, that the differential character of the excitability of the two halves of an anisotropic organ under the stimulus

stimulus in general—so similarly with regard to geotropic stimulus, there is no necessity for the assumption of any specific dia-geotropic sensibility.

Autonomous torsion.—We have now seen how torsional response is induced in an anisotropic organ. We have next to deal with that interesting class of phenomena which consists of the natural torsional movements of growing organs. It is to be remembered that, in referring to these torsional movements, we mean the torsional growth-movements of certain stems themselves about their own axes. The term *positive torsion* in such cases means a movement which appears, when looked at from above, to take place in the same direction as the movement of the hands of a watch, the term *negative* being used in the contrary sense.

Such torsional movements are found to occur in the stems of climbing plants. In some of these they are of a positive, and in others of a negative character, while in still others again they alternate, the natural torsion being, say, positive at one period, and negative at another.

Now, we have seen in the case of leaves that, owing to different rates of growth in the antagonistic upper and lower halves of the petiole, autonomous epinastic or hyponastic movements occur in a rectilinear direction. When the growth of the upper half is predominant, the movement of the organ is downwards, and *vice versa*. More complex, however, is that case in which the line of maximum growth is a spiral revolving about an axis, thus bringing about a growth-movement which causes a torsion of the organ round that axis. In the case of epinasty and hyponasty, it was said that the rectilinear movement induced was due, not to a total absence of growth on either side, but to the relatively greater growth of one of the antagonistic halves. Similarly, in these torsional movements we have to remember the existence of antagonistic elements in the stem, and it is the predominant growth of one of these, the right-handed or left-handed, that brings about the resultant positive or negative torsion.

Effect of temperature on autonomous torsion.—In order to take a record of these torsional movements, a stem is taken and held securely fixed at one end—say the lower—the other being left free. On this free end, the mirror, by the reflected light from which the record is to be made, is attached; and a long thread from above is tied to the tip of the specimen, in order to prevent its falling to one side by its own weight. The limpness of this supporting thread allows the torsional movements of the specimen to occur without hindrance.

In taking records of the natural torsional response of plants at various temperatures, I have obtained results which are in a general way similar to the records made of longitudinal growth-response (p. 446)—that is to say, the response is enhanced up to the optimum, which is at or near 35° C. Above this, response is diminished. These facts will be seen from the following table, which gives the absolute rate of the angular movements of the torsional response at different temperatures.

The specimens employed in these and the following experiments were climbing stems of *Porana paniculata*, a plant belonging to the *Campanulaceæ*, which normally exhibits a strong negative torsion.

TABLE GIVING THE ABSOLUTE RATE OF ANGULAR MOVEMENTS OF TORSIONAL RESPONSE AT VARIOUS TEMPERATURES

Temperature	Torsional movements
28° C.	·09° per minute
32° C.	·18° "
35° C.	·282° "
37° C.	·18° "

An interesting effect was observed, however, in this case of torsional response, when the temperature was raised above 43° C., which was apparently different from what occurred in ordinary longitudinal growth-response at the same temperature. It was found in the latter case that at 44° C. or thereabouts growth underwent an apparent arrest;

but this was shown not to be due to any actual arrest brought about by heat-rigor, for the rhythmic activity induced at this high temperature was even greater than before (p. 432). Now, in the case of torsional response, I find that though the rate of torsion undergoes a continuous decrease up to 42° C. or 43° C., yet beyond this an unexpected increase is induced. Thus in the experiment just described, the torsional movement at 45° C. was at least temporarily enhanced to .8° per minute. This phenomenon may be due to abnormal relaxation at these high temperatures. Or there is another possible explanation. It has been said that the resultant torsion is due to the differential growth-activities of two antagonistic elements. Now, it may be that at 44° C. or thereabouts the growth of the less excitable of these antagonistic elements may undergo the same kind of arrest as we have seen to occur in the longitudinal growth of a radial organ. The sudden increase observed at and above 44° C. in the rate of natural torsion may then be due to the withdrawal of the resistance previously offered by the growth-activity of the antagonistic element.

Effect of increased suctional activity.—Another interesting point, in connection with the occurrence of autonomous torsion, lies in the fact that its rate is enhanced by any means which tends to increase internal energy. One example of this has just been seen in the effect induced by rise of temperature. Another is found in the application of warm water to the base of the specimen, a process which has already been shown, in the case of radial organs, to cause, by means of the consequent increase of suctional activity, a sudden enhancement of the rate of autonomous growth (p. 430). I find, similarly, that the application of warm water to its base enhances the torsional response of a torsioning plant.

Effect on natural torsion of unilateral application of light.—We have seen that when an anisotropic organ is laterally excited by external stimulus, a response torsion takes place, by which the less excitable side is made to face

the stimulus. Now, in a naturally torsioning organ, such an induced torsional movement must obviously be opposite in direction to the natural movement caused by internal energy. This will be found to be illustrated in the modification induced in autonomous torsion by the unilateral application of light, as shown in fig. 272, where the first part of the curve shows the normal negative torsion of the plant. At the point marked with the upward arrow, light from a thirty-two candle-power electric lamp was allowed to strike the stem from one side. It will be seen that the excitatory effect of this external stimulus is first exhibited in the retardation of

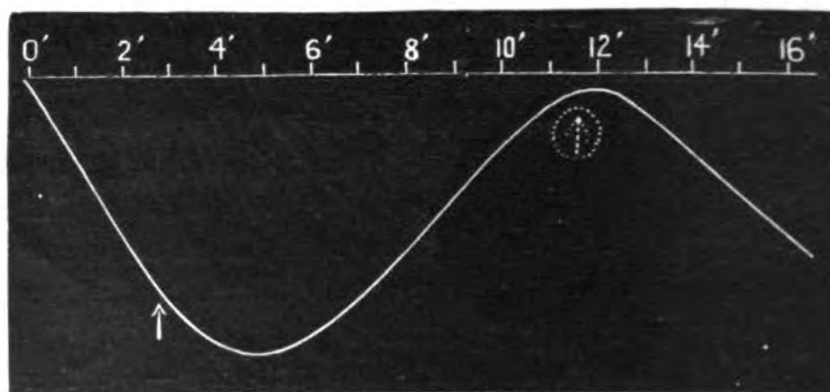

FIG. 272. Retardation and Reversal of Normal Torsional Movement by the unilateral Action of Light in *Porana paniculata*

Light applied at \uparrow retards, and in the course of two minutes reverses, the normal movement of negative torsion, making it positive. On cessation of light at \uparrow there is recovery of the original negative torsion.

the normal rate of torsion, culminating in its abolition, succeeded by actual reversal of direction. The normal negative was thus converted into positive torsion. On the cessation of the external stimulus the normal torsion was gradually resumed. The effect described is best observed in vigorous specimens in which the natural torsional movement is fairly strong.

In studying the action of light on autonomous longitudinal growth, we found that when a series of responses to the action of light were recorded, the first effect of incident

light, if the specimen were in a sub-tonic condition, would be, by increasing the internal energy, to give rise to an enhanced rate of growth; but when the normal tonic condition had been attained by absorption of light, the subsequent responses would be by a movement opposite to that of growth-elongation—that is to say, a contraction or retardation of growth. In experimenting on the effect of light on the autonomous torsional movements of the stems of certain specimens of *Ipomœa*, I have met with results exactly parallel—that is to say, the natural rate of torsional movement, in this case negative, was transitorily enhanced by the first incidence of light, but declined and underwent reversal after continued action of stimulus. In the second and subsequent responses this preliminary enhancement was found to have disappeared, the effect of light now being a retardation and subsequent reversal of the natural torsional movement.

Effect of electric current.—I have often observed a very interesting effect, as induced by a constant current flowing along the length of the organ. During the continuance of the current the normal torsional response is first decreased and then reversed. On the cessation of current there is recovery and restoration of the normal direction of torsion. If the current maintained be strong or long continued, the induced reversal may become more or less persistent. Such an induced reversal of torsion, moreover, is independent of the direction of current.

Effect of gravity.—I shall next describe a series of effects which I have only been able to obtain with any degree of certainty under favourable conditions. Where natural torsion is feeble the retarding effect of gravity which I am about to describe is such as to arrest torsion, and it is difficult to decide whether such arrest is accidental or induced. When the specimen, on the other hand, is too vigorous, the retardation is not easily observed, probably because it tends to be masked by the natural movement. In practice, therefore, the best specimens are those characterised

by moderate vigour and uniformity of natural torsion during a considerable length of time.

In studying the effect of geotropic stimulus on radial organs, we have seen that its effective intensity was greater when the specimen was inclined at an angle of 135° to the vertical than when at 90° (p. 501). It occurred to me, then, that the effect of geotropic stimulus might possibly be detected, by means of variations induced in natural torsional response at different angles of inclination. Thus, we might first take a record of the normal rate of torsion, occurring when the tip of the organ was in its natural position upwards. We might next take a record of torsion, the stem being held horizontal; and we might finally take a record with the tip held vertically downwards.¹ The effect of geotropic stimulus might then be seen in the retardation induced in the normal torsion. I give here a summary of results obtained from two different specimens of *Porana paniculata*, and from a specimen of *Ipomœa*.

In the first case, the record taken in the normal upright position gave a rate of movement of negative torsion through *minus* twenty-three divisions of the scale per minute. The record of torsion in the horizontal position was found to give a very much diminished rate, being now only *minus* seven divisions per minute; and finally, with the tip held downwards, the torsional movement of the specimen was found to have undergone an absolute reversal to positive—that is to say, the tip now moved *with* the hands of a watch at a rate of *plus* five divisions of the scale per minute.

In the second case, the normal negative torsion in the erect position was at the rate of *minus* twenty divisions per

¹ Here we must bear in mind, with regard to the effective angle of inclination, a certain difference as between radial and torsioning organs. In the former, the line of growth may be taken as vertical, and coincident with the axis, whereas in the latter it is spiral, or inclined at some undetermined angle to the axis of the organ. Hence any inclination of the growth-line of a radial organ is measured by the angle between the organ and the vertical. In the case of the torsioning organ, however, when it is held vertically downwards, its growth-line makes an angle—not of 180° to the vertical, but—of 180° less by the degree of its inclination to the axis.

minute. This was reduced in the horizontal position to *minus* fourteen divisions per minute, and in the vertically downward position it was found to have undergone reversal to *plus* nine divisions per minute.

In the next series of experiments I took records from specimens held alternately up and down and up again. This was done in order to eliminate the effect of any chance variation. The specimen employed was *Ipomœa*. The torsional response in the first up position was at the rate of *minus* sixteen divisions per minute. When held in the inverted position, the rate was found reduced to *minus* ten divisions per minute, and when once more placed in its normal vertical position, the *Ipomœa* exhibited an increased rate of movement—that is to say, the torsion now took place at the rate of *minus* twenty divisions of the scale per minute.

All these results tend to show that the action of stimulus of gravity is to retard the autonomous torsion, this effect being at a maximum when the specimen is in a position at 180° from the vertically upright.

The twining of stems.—The twining movements of certain stems are the result of various contributing factors, the relative values of which may differ in different cases. One such factor, suggested by Von Mohl and denied by others, may lie in the irritability of the stem to the contact of its support. Such response to unilateral pressure was found to occur in various organs (p. 497), and probably plays an important part, in some cases, in the phenomenon of twining.

Some connection would also seem to exist, in many instances, between autonomous torsion and twining. In the first place, most of the twining plants also exhibit autonomous torsion. Again, just as we have various types of torsioning organs—some characterised by positive, others negative, and others again by positive alternating with negative, or negative with positive, torsions—so in twining stems also, we see some which exhibit positive-directioned twining, others negative, and others again alternately one and the other. A plant, moreover, which has twined, shows, if inverted, a tendency

X X

towards reversal or untwining. This is analogous to the effect of inversion on autonomous torsion, in which, as we have seen, the original torsion tends to be reversed.

The effect of gravity is known to be a very important factor in the induction of twining. It is believed that we have here a third type of geotropic action, which is neither positive nor negative, but lateral in its character. Under lateral geotropism, a curvature is induced in the twining stem in a horizontal plane. Since we have found, however, that even such diverse effects as positive and negative geotropic actions are not to be regarded as due to different specific sensibilities, it would be interesting to inquire whether lateral geotropism also is not simply a case of ordinary apogeotropism in combination with some other tendency, say that of autonomous torsion.

At any rate, that this erectile or apogeotropic action is always an element in the process, is shown by the fact that the coils in the older portion of the stem become drawn out, showing that the ascending movement predominates in that region.

The whole subject is, however, extremely complicated, owing to the presence of many factors and their different relative intensities. And each of these may again be subject to modification, under the action of external stimulus, as was seen to be the case with autonomous torsion under the influence of light, gravity, and the variation of internal energy.

SUMMARY

The observed effect of torsion, by which the upper surface of the leaf is turned to face the light, is not due to any specific dia-heliotropic sensibility.

Similar torsional response is induced by the lateral application of any other form of stimulus, such as thermal or chemical.

Such torsional response is also obtained from a compound strip made of two unequally contracting inorganic materials, such as ebonite and stretched india-rubber, when stimulus is applied to one of the lateral flanks.

The general law of induced torsional response is that the less excitable side of the organ is made to face the incident stimulus. If the excitability of the lower half of the pulvinus be artificially abolished by the local application of chloroform, the torsional responsive movement is reversed. The leaf now executes a movement by which its lower surface is made to face the light.

On artificially increasing the natural difference, as between the two halves, by altogether abolishing the excitability of the upper, the normal torsional response is accelerated.

That the upper and lower halves of a dorsi-ventral organ are unequally sensitive to geotropic stimulus is shown by the fact that they give torsional response, under which the less excitable half is carried so as to face the incident lines of gravitational force. An artificial increase of this natural difference of excitability has the effect of accelerating the rate of torsional response. The artificial reversal, on the other hand, of these relative excitabilities has the effect of reversing the direction of the natural responsive movement.

From these considerations it is seen that none of the responsive movements caused in dorsi-ventral organs by light or gravitation are due to any specific dia-heliotropic or dia-geotropic sensibility, and that they are in reality due to the differential excitability of the two halves of the organ.

The autonomous torsional movement of growth increases in rate up to an optimum temperature, after which it begins to decrease. There may be a second acceleration after the attainment of the first minimum.

This autonomous torsional movement is retarded or even reversed in sign by unilateral stimulus of light. A constant current, flowing along the length of the organ, often retards or reverses the normal autonomous torsion. The stimulus of gravity also has the effect of retarding or reversing normal torsional movement. The effective intensity of this stimulus appears to be greatest when the organ acted upon is in a position at 180° from the vertically upright.

X X 2

CHAPTER XLVIII

NYCTITROPIC MOVEMENTS

Comparison between nyctitropic and autonomous pulsations—Diurnal movement of plagiotropic stem—Supposed distinction between nyctitropic and other movements of response to stimulus of light—Diurnal response of leaf of *Biophytum*—Diurnal response of primary petiole of *Mimosa*—Periodic impulses acting on the leaf—Periodic impulses contributed by the plant as a whole—Other modes of exhibition of diurnal periodicity of hydrostatic tension—Forced vibration and its periodic after-effects—Physical analogue—Impressed periodic vibrations in organ originally radial.

IN addition to the other effects of light which we have been studying, there is also a periodic movement, induced by the alternation of day and night, which consists of a pulsation executed by the responding organs in the very long period of twenty-four hours. In its pulsatory character this movement resembles the so-called autonomous pulsations of such leaflets as those of *Desmodium gyrans*. But besides the fact that it has the long and definite duration of twenty-four hours, whereas the autonomous pulsations of the leaflets of *Desmodium* are short and variable in period, there are other differences between the two.

Comparison between nyctitropic and autonomous pulsations.—In the first place it will be noticed with regard to the daily periodic movement that at any given time all the motile organs of the same plant are going through the same phase. This rhythm therefore is in a manner controlled by the plant as a whole. In the case of autonomous movements so called, on the other hand, the seat of rhythm is localised in the motile organ of that particular leaflet whose pulsations are being observed, and there is no necessary coincidence of period, as between any two leaflets on the same plant. The

period of autonomous vibration is much modified, again, by rise or fall of temperature, and other conditions ; whereas the daily period is unaffected by these circumstances. This is due to the fact that the autonomous pulsations are akin to free or natural vibrations, whereas the daily periodic movements are, as we shall see, of the nature of forced vibrations.

As the nyctitropic movement in the primary petiole of *Mimosa* is of a simple character, free from those other complicating considerations which have to be taken into account in the case of the leaflets, this organ has been chosen as the typical specimen by many investigators. We shall therefore consider in detail all its peculiarities in regard to this movement, but I shall at the same time endeavour by the use of the comparative method to trace the evolution of the movement, as first seen in plagiotropic stems, more clearly manifested in certain dorsi-ventral organs like ordinary leaves, and strongly exhibited in pulvinate leaves, such as those of *Mimosa*.

Supposed distinction between nyctitropic and other movements of response to stimulus of light.—This nyctitropic movement has been sharply distinguished from ordinary response to the stimulation of light, by the statement that while the latter depends on the direction, this is determined only by the *varying intensity* of illumination. As a further distinction, it is also insisted that, whereas the responsive curvature induced by light takes place in all directions, nyctitropic movement always occurs in a single definite plane.

But whenever we subject the pulvinus of *Mimosa* to the action of strong light, we obtain response by a greater or smaller depression or fall, which occurs in a definite vertical plane, and is precisely the same in character as that which is exhibited slowly during the course of the whole day, and attains its maximum in the evening. This response to strong light, moreover, is always the same, on whichever side of the pulvinus the stimulus may act—that is to say, it is independent of the direction of light. In analysing this case

further (p. 635) we saw that it constituted a true instance of phototropic reaction, and that this particular movement of fall in a definite direction was due to the stimulus being diffused, whether internally or externally, and by differential action inducing concavity of the lower and more excitable half of the pulvinus.

In the assumption by the leaf at evening, then, of its lowest position, we have nothing which is specifically different from this responsive movement, as caused by the action of light on the anisotropic organ; but this same fall, when it attains its maximum in the evening, as a phase of the nyctitropic movement, is usually said to be due, not to the stimulus of light, but to the *variation* in that stimulus, or to the effect of on-coming darkness. Now, if it had been true that the diminution of light, or on-coming of darkness in the evening, had acted in some unknown manner as a stimulus to bring about the fall, then we should have found that such a fall was at that time extremely rapid, and that it persisted on the withdrawal of light during the night. As a matter of fact, however, it is found that this movement of the petiole downwards has been taking place progressively throughout the day, and that the fall of the leaf at evening is merely a continuation of this previous movement, and not markedly more rapid at that time than before, if the increased mechanical moment due to the closing of the secondary petioles and their leaflets be eliminated by their removal. Nor does the petiole remain in this depressed position, but begins after an interval to erect itself, till in the morning, or earlier, it has attained its highest degree of erection. So far, again, from darkness being efficient to cause the depression of the leaf, it is well known that on artificially darkening the *Mimosa* plant the leaves respond by erection.

It is thus clear that we must seek some other explanation of the nyctitropic movement, and as it is known that such periodic movement persists for a time, even when the plant is kept for days in continuous darkness, the inquiry resolves itself into the two questions: (1) how are these diurnal

motile impulses generated? and (2) how is it that the movement will still persist in the absence of a periodically exciting cause?

Diurnal movement of plagiotropic stem.—In order to understand clearly the periodic action of light, in inducing diurnal movements, it is best to take as our starting-point the simplest type of anisotropic organ, in which this effect may be observed, and for this we may select the plagiotropic stem of, say, *Cucurbita*. This creeping stem is acted on, under natural conditions, by vertical light from above, the excitatory effect of which, by long-continued action, reaches the lower and more excitable side. The stimulus thus becomes internally diffused, and there is also a certain amount of externally diffused light from the environment. Hence it happens that, by the contraction of the more excitable lower half, the free end of the stem becomes progressively depressed, under the continued action of light, during the course of the day (p. 627). We have seen that in consequence of this the greatest depression occurs about the time of evening, and that on the cessation of the stimulus of light there is a recovery, the stem erecting itself more and more as the night advances (fig. 252). *Thus this nyctitropic depression at nightfall is not due to the on-coming of darkness, but represents the cumulative responsive effect of the day's illumination.* In fact we may regard the responsive movement down, and recovery up, which are executed in the course of the diurnal period, as parallel to that phenomenon with which we are already familiar, of a single response to a single transient stimulus. The only difference lies in the fact that, while in this latter case the whole process is completed in a few minutes, in the former the stimulus acts continuously during something like twelve hours, and the recovery is allowed to take place during the course of the night. Thus, in the ordinary case of records of uniform responses to uniform stimuli, the successive stimuli, each lasting for a few seconds, are given at intervals of some minutes, but in the case of the diurnal responses we have a series of stimuli,

each lasting for twelve hours, and the beginning of each separated from the next by a period of twenty-four hours.

Diurnal responses of leaf of *Biophytum*.—From this simple instance of anisotropy we pass on to a more highly differentiated case of dorsi-ventrality, as seen in leaves. We have already seen that the petiole of *Biophytum* is only provided with a moderately developed pulvinus, and that the petiole also, as a whole, acts as a diffuse pulvinoid. In this

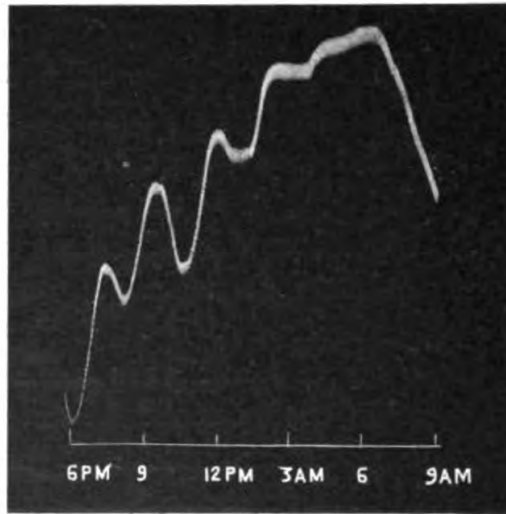

FIG. 273. Photographic Record of Diurnal Movement of Petiole of *Biophytum* from 5 P.M. till 9 A.M.

First part of record shows maximum depression to be reached at 6 P.M. and maximum erection at 7 A.M. After the latter hour the leaf again begins to exhibit its usual daytime depression.

case also, by the internally and externally diffused action of light during the course of the day, the petiole is progressively depressed, from its position of highest erection in the morning to its lowest depression in the evening. Recovery takes place again in the absence of the stimulus of light, and the leaf once more assumes its highest position by morning. If, however, in the course of the afternoon, say, at five o'clock, the plant be

taken to a dark room, then, owing to the positive after-effect, the leaf will still continue to fall for about an hour, and then begin to erect itself. Owing to the daily periodicity impressed on the plant, of which we shall presently speak in greater detail, the leaves continue to exhibit the diurnal movement even when kept in continuous darkness. I give here (fig. 273) an interesting photographic record of the diurnal movement of the leaf of *Biophytum* from 5 P.M., when it was brought into the dark room, till 9 A.M. next morning. It will here be seen that, owing to the

positive after-effect, the leaf continued to fall till 6 P.M., and that after this it erected itself by a series of five pulsations, until its highest position was attained at about 7 A.M. It next began to exhibit the impressed effect of day, and the leaf then fell rapidly.

Diurnal response of primary petiole of *Mimosa*.—In *Mimosa* we merely find the repetition of those movements whose evolution we have already traced through the plagiotropic stem and the dorsi-ventral petiole. This is made very

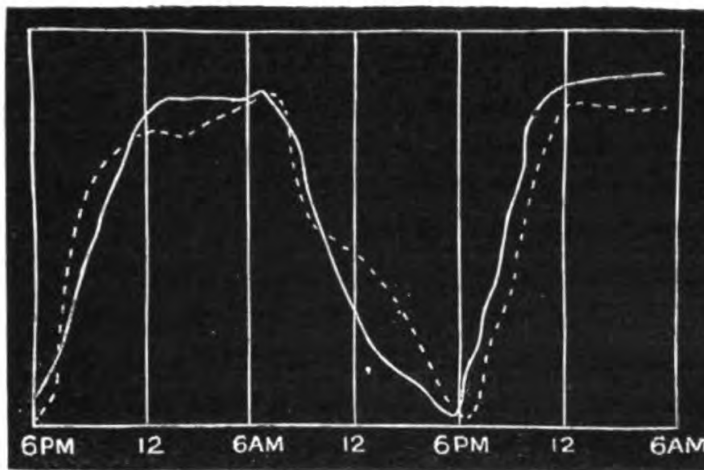

FIG. 274. Continuous Records of the Diurnal Movement during Thirty-six Hours in Two Specimens of *Mimosa*

The continuous line represents the movement of the one-year old, and the dotted line that of the six-months old specimen. The maximum depression is seen to take place at six in the evening, and the recovery nearly completed by midnight. This maximum erection is slightly augmented at dawn.

apparent in the continuous records which I took of the diurnal movement in two specimens of *Mimosa*, the records being continued during a period of thirty-six hours (fig. 274). The two plants were placed in an open verandah, and long light indices made, as already described, of peacock's quills, were so attached to the petiole as to form prolongations. Records were taken on a vertical revolving drum. A vertical thread was suspended in front of the drum, and the point at which the moving index cut this vertical line was marked at every fifteen minutes. Thus the record gives

a measure of the angular movement at different parts of the day. The dotted line shows the diurnal movement of the younger of the two plants, which was six months old, and the continuous line that of the other, which was one year old. The two, as will be seen, are practically the same. It should be mentioned here that, when this record was taken, 6 A.M. and 6 P.M. were the hours of sunrise and sunset, there being no twilight. The records show that the leaves exhibited the erectile or recovery effect with great rapidity during the first part of the night, this movement being almost completed by 1 A.M. After this there was but slight upward movement, until about 7 A.M., from which time onwards, during twelve hours, they fell continuously. The maximum depression was reached at almost exactly 6 P.M., and then the leaves again rose, repeating their former movement of recovery.

Periodic impulses acting on the leaf.—The periodic movements down during the day, and up during the night, are thus seen to be due to periodic impulses of stimulus and recovery acting on the responding leaves. It must be pointed out here that the process of recovery is not altogether passive. We saw in the records of *Mimosa* under light (fig. 256) that, on the cessation of light, the responding leaf continued to move down for a while owing to the positive after-effect. Later, however, owing to the latent energy which it had acquired by the absorption of light, it exhibited the negative after-effect in an erection which carried it beyond the original position. Hence we can see that the increased internal energy due to previous absorption of light plays an important part in that movement of erection which is initiated shortly after nightfall. We may therefore say that the diurnal movements of the leaves are brought about by two alternate periodic impulses, those, namely, of external stimulus and internal energy. The persistence of the effect of each of these impulses will depend on the intensity of the two factors respectively, and also on the capacity of the tissue for absorbing stimulus. For example, the positive after-effect by which the leaf continues

to be depressed, even on the cessation of the stimulating daylight, may, in some cases, be short-lived, and in others may continue for a considerable period. The return movement will in the latter case be somewhat delayed. Again, the internal energy which hastens recovery may, in certain cases, bring about the utmost erection of which the leaf is capable at some time earlier than the ensuing morning. Thus, for example, in the response of *Biophytum*, the highest position (fig. 273) was attained at about 7 A.M., while in the records of these particular *Mimosa* leaves the corresponding point was reached very much earlier, that is to say at 1 P.M.

Periodic impulses contributed by the plant as a whole.—In addition, however, to those periodic impulses whose seat is in the responding leaf, there is another concordant impulse contributed by the plant as a whole which intensifies the diurnal movement. The plant is subjected during the day to the stimulus of light, which causes contraction of the exterior tissues, and thereby tends to drive the water inwards. The turgidity of the cortex is thus progressively diminished during daylight. But at night the water which has thus been driven into the central reservoir of the plant will flow outwards. In this also the absorbed energy will play an important part. The rhythmic activity of the cortical tissues being thereby increased, they will suck water outwards from the central reservoir, just as the rootlets suck it from the ground. The result of this alternation of external stimulus during the day, and internal stimulus during the night, will be a periodic inflow and outflow—a diminution and increase of tension—the first half of the cycle being completed in the daytime, and the second half in the night.

I have shown (p. 46) that the leaf of *Mimosa* is erected whenever the internal hydrostatic tension is artificially increased, and depressed when it is diminished; and we have seen how such variations are induced by the alternation of day and night, not only in individual petioles, but throughout the plant as a whole. The alternate ebb and flow of the water, from the central reservoir, will thus be

indicated by the periodic erection and depression of all the leaves synchronously, which will thus act, so to speak, as signal-flags.

Other modes of exhibition of diurnal periodicity of hydrostatic tension.—There are also other modes besides that of mechanical response of the leaves by which this diurnal periodicity of tension can be detected ; and Millardet has shown that the maximum tension in *Mimosa* occurs at dawn, when the primary petiole is in its most erect position. The minimum tension, again, occurs in the evening, when the leaf occupies its most depressed position. Kraus, further, has found the organs of the plant diminish in bulk from morning till afternoon, and that the reverse process takes place from afternoon till morning. Growth itself, again, is well known to exhibit a diurnal periodicity. It is interesting, however, to realise that this is simply the mode by which a radial organ exhibits, in a form of longitudinal response, what was otherwise exhibited in *Mimosa* as lateral response. The periodic variation of tension induced by the diurnal period has been seen to manifest itself in *Mimosa* in two alternate movements, positive and negative. Similarly we shall find, in growth-response, positive and negative variations above and below the normal or average rate. If we take a balanced record of growth, representing its average rate, a downward line will indicate retardation or negative response, while an upward line will indicate an acceleration of growth, or positive response ; and in thus recording variations of the rate of growth, by the balanced method, for a period of twenty-four hours, we obtain, as we have seen (fig. 191), a curve which closely resembles that of the nyctitropic movement.

Forced vibration and its periodic after-effects.—We have thus traced out the two alternating impulses—the direct effect of external stimulus and its direct after-effect, and the internal stimulus with the negative after-effect—which induce the *forced* vibration of the responding organ. The periodic effects of protoplasmic contraction and expansion, induced

alternately in the plant under alternating light and darkness, thus leave a molecular impress, and this impression is deepened by repetition, finding subsequent expression even when the primary alternating cause is absent. The length of time during which such after-oscillation persists will depend, amongst other things, on the depth of the molecular impression.

Physical analogue.—An analogous physical phenomenon will make the point clearer. If a wire be taken and subjected to alternating molecular strains, say by giving it alternate positive and negative twists, the wire being held in each of these twisted positions for a time, then, even after stoppage of such alternate twisting movements, the released wire will continue to vibrate to and fro in expression of the release of impressed latent strains, consequent on previous forced vibrations.

That such forced vibrations may persist in a plant has been shown by F. Darwin and D. Pertz, who subjected a plant to alternating geotropic stimuli, by which a rhythmic movement was found to persist for a time, even on the stoppage of stimulation. Czapek and Wiesner obtained similar after-vibrations with alternating phototropic stimuli.

Impressed periodic vibrations in organ originally radial.—I shall here give a very remarkable instance of such forced periodic vibrations, as induced in an originally radial organ. I had a row of sunflowers planted, in a line which ran accurately east and west, at the season when the sun moved daily in an almost vertical plane. The plants were thus stimulated in the morning from the east, and in the afternoon from the west. All these plants, then, by heliotropic action, followed the path of the sun during the course of the day, and during the course of the night, again, there was recovery. At first the diurnal swing east and west was only through a small angle, but under the action of these repeated periodic impulses it became larger and larger, like that of a pendulum under regular and repeated blows. When the plants had grown to a height of one metre, it was

a remarkable sight in the early mornings to see all the six, with their upper halves bent over equally to the east, and in the evenings equally to the west. One curious phenomenon connected with this consisted in the fact that not only was the nightly recovery completed by 1 A.M., but the upper part of the shoot was already carried over to the east, just as we found the *Mimosa* leaf to be erected to the highest position by midnight in consequence of the presence of internal energy.

Analysis of constituent impulses causing nyctitropic movement.—Nyctitropic movements are thus brought about by two different periodic factors, themselves induced by the periodic action of light and darkness. These periodic forces acting on the pulvinus are :

1. The differential heliotropic effect on the pulvinus itself. By the stimulus of light, externally and internally diffused, the dorsi-ventral leaf is progressively depressed during the day. The reverse process takes place at night, by means of natural recovery, aided by internal energy, which gives an impulse opposite to that of external stimulus.

2. A periodic inflow and outflow of water taking place in the plant as a whole, by the recurrent action of light and darkness. This, acting on the dorsi-ventral pulvinus, causes periodic movement of the petiole.

3. Both these periodic forces are concordant in their action on the pulvinated organ, and give rise to periodic movements of large amplitude.

SUMMARY

The nyctitropic movement of such leaves as that of *Mimosa* is believed to be distinguished from heliotropic action proper by the facts that (1) it takes place in a definite plane, and (2) it is caused, not by light as a constant force, but by its variation of intensity, the fall of the petiole in the evening being thus ascribed to the on-coming of darkness.

With regard to the first of these points, I have shown that, even under heliotropic action proper, all dorsi-ventral organs move in a definite plane ; and as regards the second,

it has been shown that the fall of the leaf in the evening is not due to the action of on-coming darkness, but to the cumulative stimulation of the day's illumination—that is to say, to the action of light as a constant force.

It is possible to trace out the gradual evolution of this periodic diurnal movement, taking as the simplest type that of the plagiotropic stem. Under the action of stimulus, which is internally or externally diffused, the lower and more excitable side of such a stem undergoes progressive concavity, the lowest position being attained in the evening. At night, however, on removal of the stimulus of light, recovery takes place by erection of the stem. A diurnal up-and-down movement is thus induced.

A similar effect is observed in the petiole of *Biophytum*.

In the leaf of *Mimosa* the action is precisely the same. Here, owing to the direct action, and the positive after-effect of light, the leaf is depressed progressively till evening. At night, however, recovery takes place by an erectile movement. This is not due to a passive recovery merely, but is aided by the negative after-effect, consequent on the storage of internal energy by the day's illumination. By this active internal impulse the leaf attains its highest position some time before dawn. The alternate impulses acting periodically on the leaf are thus: (1) the direct effect of continuous stimulation of light, and (2) the opposite impulse due to internal energy.

In addition to these alternate impulses the plant as a whole contributes periodic impulses, which are concordant with the periodic impulses in the leaf. The external tissues of the plant, acted on by light stimulus, contract and drive the water inwards, into the central reservoir. At night a reverse movement of water takes place. As a result of this alternation of external stimulus during the day, and internal stimulus during the night, there is a periodic inflow and outflow, a diminution and increase of tension, and these variations of tension are indicated by the periodic depression and erection of all motile leaves synchronously.

The fact that these periodic forces in leaves and in plant act concordantly causes the periodic movements to be of large amplitude.

The periodic diurnal variations of internal hydrostatic tension are also exhibited by periodic variations in the rate of growth. The curves of the diurnal periodicity of growth and of the nyctitropic movement of the leaf are therefore similar.

This forced diurnal vibration, being often repeated, gives rise to periodic after-effects, which persist for a time even on the cessation of the periodically exciting cause.

CHAPTER XLIX

ON PULSATORY RESPONSE AND SWIMMING MOVEMENTS AS INITIATED AND MODIFIED BY LIGHT AND OTHER FORMS OF STIMULUS

Investigations on the influence of light on the lateral leaflet of *Desmodium gyrans* :
(a) in sub-tonic condition ; (b) in normal tonic condition - Changes induced in
existing anisotropy of *Desmodium* leaflets—Reversal under intense stimulation
seen in all forms of response—The swimming movements of ciliated organisms
—Fundamental resemblance between the swimming responses and the ordinary
heliotropic responses in radial organs—Phototactic movements : (a) Two
natural types of responsive movements ; (b) Responsive movement positive,
negative, or intermediate, according to intensity of stimulation—Directive
action of light—Thermotaxis--Galvanotaxis—Chemotaxis.

WE have already studied in detail the autonomous responses of the leaflets of *Desmodium* ; but there are also other leaves which execute similar pulsatory movements, and we have now to investigate the effect of the stimulus of light on such multiply-responding organs, either in initiating these movements or in modifying them. We have also another instance of such multiple pulsations, in the swimming movements of ciliated organisms, of which the causes are at present regarded as very obscure. The treatment of these I include within the present chapter, because I hope to show that they really belong to a class of phenomena essentially similar to the autonomous movements of *Desmodium*, and that from this point of view all their seeming peculiarities may be very satisfactorily explained.

In the first place, I shall take up the question of multiply-responding leaves or leaflets. Concerning the effect of light on these, there is a certain amount of discrepancy of observation. Strasburger, for example, referring to such movements

Y Y

in the lateral leaflets of *Desmodium gyrans*, says they are in no way disturbed by variation in the intensity of light. According to Pfeffer, similarly, the autonomous movements of the leaflets of *Trifolium pratense* are not affected by illumination. But Strasburger again states that the leaflets of this plant, on exposure to light, cease their oscillations.

Investigations on the influence of light on the lateral leaflet of *Desmodium gyrans*.—(a) In sub-tonic condition.—A clearer insight into this subject will, however, be obtained when I describe my experiments on *Desmodium gyrans*. I have shown that when this plant is in a sub-tonic condition it behaves like an ordinarily responding plant, such as *Biophytum*; a single moderate stimulus then evokes a single response, and strong stimulus multiple responses. Thus a leaflet of *Desmodium* in a state of standstill has multiple response initiated by the incident stimulus of light. The following record

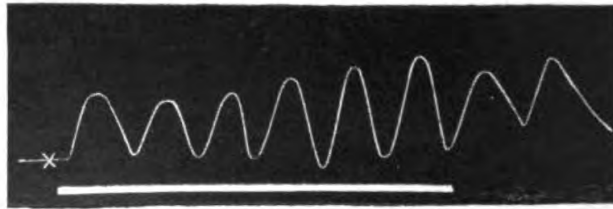

FIG. 275. Initiation of Multiple Response in Lateral Leaflet of *Desmodium* originally at Standstill

Light applied at × and continued till the end of the sixth response, as shown by the thick line. The responses show a staircase increase with increase of absorbed energy. Pulsations persist for a short time even on the cessation of stimulus.

(fig. 275) shows this clearly. The leaflet was in a quiescent condition, but during the application of light it exhibited multiple responses, which, owing to the increasing absorption of energy, showed a staircase enhancement of amplitude. On the cessation of light the energy absorbed maintained the pulsation for some time.

(b) *In normal tonic condition.*—When the specimen, however, is in a favourable tonic condition, its pulsations being

apparently autonomous, the application of excessive stimulus of strong light often brings about fatigue, and under these circumstances I have obtained two different types of response, according to the particular condition of the tissue. In the first of these, progressive fatigue, under the continued action of light, is shown by the gradual diminution of amplitude of pulsation. If the strong stimulus of light, which causes this fatigue, be applied for a short time only, the pulsation whose amplitude was diminished, again on the cessation of stimulus recovers its first amplitude in a staircase manner; but if the light be long continued, fatigue becomes so great that the pulsatory movements are brought to a stop, at least for a considerable period. We have seen again that an organ sometimes exhibits fatigue somewhat differently from this, that is to say in a periodic manner. In accordance with this fact the leaflets of *Desmodium* are sometimes seen to display periodic fatigue—that is to say, the pulses wax and wane in groups, an example of which is seen in fig. 276.

Thus we see that in a leaflet at standstill, light, by supplying energy, initiates autonomous movement; while in an actively pulsating leaflet, strong illumination may bring about such fatigue as to cause cessation of movement. At still other times, again, owing to the favourable condition of the tissue, fatigue is slight, and there is no arrest of activity. These facts are sufficient to explain the discrepancy already mentioned, in the observations made by Strasburger and by Pfeffer, on the action of the leaflets of *Trifolium pratense* under light.

Changes induced in existing anisotropy of *Desmodium* leaflets.—A very interesting consideration arises at this point as to the differential fatigue caused in the anisotropic organ by strong stimulus. We have seen that the lower half of such an organ is the more excitable, hence we can see the probability of fatigue being relatively greater there. Now, it is the naturally greater excitatory contraction of the lower half of the organ which causes the downstroke of the leaflet

Y V 2

to be the quicker ; but if stimulus produce greater fatigue of the lower half, we can see that its movement will be made somewhat slower, and the upstroke will then become the relatively quicker of the two.

This anticipation finds remarkable verification in the photographic record given in fig. 276. We see there, in the first or normal record, from the fineness and steepness of the upward line, representing the downstroke, that this is the quicker movement of the two ; but after the application of strong stimulus of light, at the point marked with an upward

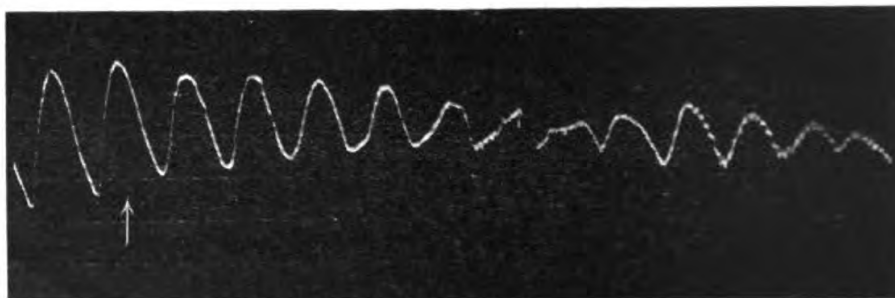

FIG. 276. Photographic Record of Autonomous Pulsations in Lateral Leaflet of *Desmodium gyrans* under Action of Sunlight, showing Periodic Reversals

Light applied continuously from arrow onwards. In the first two responses, representing the normal, the downstroke of the leaflet, represented by the up curve, is relatively the quicker. After the application of light, this relation is gradually reversed, till in the fourth and fifth pulses after application it is the upstroke, represented by the down curve, which is pronouncedly the quicker. This reversal is in its turn reversed at the eighth pulsation.

arrow, we observe a gradual change, by which the existing normal difference between up and down strokes is first abolished and then reversed. In the next complete response, after the application, we see that the two strokes have become equally rapid. In the next, the downstroke has become distinctly the slower, and this goes on progressively till we see in the fifth of this series a very remarkable degree of difference between the two, the upstroke being now much the quicker. These reversals are found to be recurrent, further on in the record. Such alternate changes of excitability on the two sides we have noticed even in the case of radial organs ; for

we have seen that such an organ, when acted on unilaterally by strong light, often exhibits to-and-fro oscillations, due to alternate fatigue of the two sides.

We thus find, starting with a *Desmodium* leaflet in a state of standstill, that moderate intensity of light initiates normal pulsatory movements, in which the downstroke is quicker than the upstroke; but, in a pulsating leaflet, under intense or long-continued light, these beats are reversed, that is to say the upstroke becomes the quicker. Under the action of continuous light, again, these reversals themselves may become periodic or recurrent.

Reversals under intense stimulation seen in all forms of response.—We have already seen that autonomous pulsation is simply ordinary response repeated, owing to excess of energy; and that the *Desmodium* leaflet is an ordinary anisotropic organ, in which response may be initiated by any form of stimulation—thermal, photic, chemical, or electrical. We have just seen, further, in the case of photic stimulus, that the character of the response may be reversed by the intensity of the stimulation. Thus the normal response, in which the downstroke is more energetic than the upstroke, may be exchanged for a type of response in which the upstroke is quicker than the down. This law of reversal of response with varying intensity of stimulation has already been shown to be illustrated in different types of response. For example, in the case of chemical stimulation, we found that the leaf of *Mimosa* when subjected to the action of a dilute solution of sodium chloride gave an erectile response, whereas when the solution was stronger it responded by depression (pp. 551, 552). In the response of growth, again, very dilute and very strong solutions of a given reagent were shown to produce opposite effects. Thus, while dilute solution of sugar accelerated, a very strong solution retarded, the rate of growth (p. 488).

In the case, then, of an organ which is capable of multiple response, we find that any form of stimulus is competent to initiate such response, and that, with regard to certain charac-

teristics, such as the relative quickness of the up or down movement, it may be exhibited in opposite ways, according to the intensity of stimulus.

The swimming movements of ciliated organisms.—It is the automatic character of ciliary movements which has hitherto rendered them a subject of such great perplexity, for these movements are independent of any nervous system for their initiation or control. The impulses that lead to ciliary motion arise in the cilia themselves. There is, again, some difficulty in understanding the mechanics of these movements.

Their automatism may, however, be explained by those considerations which are now familiar to us in similar instances—that is to say, initiation of movement by external stimulus, and its maintenance by excess of latent energy. There is, again, the closest resemblance, from a mechanical point of view, between the movements of the cilia and the movements of *Desmodium* leaflets. In both cases alike, one of the component strokes is quicker than the other. Again, though in both cases we meet with instances in which the up and down movements take place in the same plane, yet there are also others in which more complicated paths, whether circular or elliptical, are described. The fact that one movement is quicker than the other, and that the strokes are lateral, shows that we have in the cilium an anisotropic organ, essentially similar to the pulsating pulvini of the lateral leaflets of *Desmodium*. The only difference between the two cases lies in the fact that we have in the pulvinus a multicellular, and in the cilium a unicellular, organ.

Let us suppose a detached petiole of *Desmodium*, bearing the lateral leaflets, to be thrown into water contained in a glass trough ; let us further suppose these leaflets to be in a sub-tonic condition, that is to say in a state of standstill. If this vegetable organism be now stimulated by sunlight of moderate intensity, striking it horizontally from one side of the vessel, it will be found that rhythmic excitation is initiated, and that the stroke backwards is much quicker and

more energetic than that forwards. The consequence of this will be, in the vegetable organism as in the case of a man swimming, its forward propulsion. This result depends upon the fact that the lower half of the anisotropic organ is in this case the more excitable. Reversal of the relative activities of the two halves of the dorsi-ventral organ was, however, seen to occur in the case of the leaflets of *Desmodium* when the intensity of stimulation was very great. Such a reversal, under excessive stimulation, would give rise then to a swimming movement in the opposite direction. We also saw such reversals under continuous stimulation of light becoming periodic (fig. 276). The corresponding swimming response would thus consist of a movement to and fro.

Supposing, however, that the excitability of the upper half of the motile organ had been the greater, it is clear that the normal excitatory response would have taken the form of a backward or negative swimming movement. We thus see the possibility of normal responsive swimming movements of two different types, according to the particular half of the anisotropic motile organ which is the more excitable. Taking, again, that type of swimming in which the response is positive or forward, a stronger intensity of stimulation may give rise to a reversal, or negative movement. And from what has already been said, it will be seen that similar responsive movements may also be expected under forms of stimulation other than light.

Similarity between swimming responses and the ordinary heliotropic responses of radial organs.—Though at first sight it would appear as if there were no connection between the simple responsive curvatures of radial organs and the apparently complicated responsive movements of swimming, yet on a closer analysis we shall find that there is little essential difference between the two; for we have seen that growth itself, or growth-curvature, is simply a phenomenon of multiple responsive movements, which, owing to the rapidity of the individual responses, appears continuous. Hence, when, under moderate stimula-

tion, the organ moves towards the light, or exhibits a positive response, this means that the resultant of its multiple movements is towards the stimulus, like the resultant movement of the ciliated organism towards light. Similarly, under strong photic stimulation, the negative heliotropic movement of the organ corresponds to the swimming of the ciliated organism away from light. In the intermediate case, again, where the stimulated organ shows no resultant curvature, but oscillates about a mean position, we have an instance which is paralleled, in the case of the ciliated organism, by alternate swimming backwards and forwards.

Again, just as in the heliotropic response of a radial organ, the minor pulsations by which it is brought about are too rapid and minute to be easily detected, and we can perceive only the resultant movement of the organ as a whole, so in the case of the ciliated organism the individual beats cannot easily be perceived, and we infer their presence from the resultant motion of the organism as a whole.

Phototactic movements.—From the fundamental demonstrations which I have already given of the characteristics of multiple response, and its modification by relative variations of contractility, as between the upper and lower halves of the responding organ, it will be found that the multifarious responsive movements of ciliated organisms, under various forms of stimulus of differing intensities, will have been elucidated.

(a) *Two natural types of responsive movements.*—The two opposite types of movement, positive and negative, which we have now theoretically anticipated, are found to be completely illustrated in the case of swarm-spores under the action of light. Thus, for example, in the case of *Botrydium granulatum*, they respond by a positive swimming movement, or motion towards the light. Again, while certain varieties of *Ulothrix* exhibit the positive effect, by movement towards light, there is another variety which gives the negative response, by swimming away from it. This opposition of effects is obviously due, as we have anticipated, to a

natural difference of relative excitabilities, as between the upper and lower halves of the anisotropic swimming organ (p. 695).

(b) *Responsive movements positive, negative, or intermediate, according to intensity of stimulation.*—Turning now to the question of different movements in the same organism as modified by the varying intensity of illumination, examples are furnished by the observations of Stahl and Strasburger. These investigators find that the swarm-spores, generally speaking, when the intensity of light is moderate, move towards it, and when stronger, away.

In the lateral leaflets of *Desmodium*, again, under continuous illumination, we have observed recurrent reversals of the direction of the more rapid of the two strokes which constitute each individual pulsation. Even this phenomenon finds a curiously exact parallel in the movements of certain swarm-spores of *Ulothrix* under the continuous action of light, as noticed by Strasburger. These he finds first to retire from the light, then to remain stationary, and again to return towards the light, only then to begin the whole process over again, thus moving to and fro for some time like a pendulum.

Directive action of light.—The movement of the ciliated organism, then, whether towards or away from it, is parallel to the direction of incident light. But a difficult question arises here as to how the organ perceives this direction as it were, and by what mechanism it determines its own course accordingly. At first sight, there appears no reason why rhythmic beats caused by stimulus should not produce propulsive movement in any direction. In this connection, turning to the case of *Ulothrix*, we find the organism provided with symmetrical pairs of cilia. We also know that the excitatory effect of stimulus of light depends upon its angle of incidence. If, then, light strike the two cilia of a given pair asymmetrically, they will undergo unequal excitation, causing them to execute a turning movement. Thus a stable condition can only be arrived at when excitation is

equal in the two cilia, and this can clearly happen only when the organism has so orientated itself that its axis is parallel to the direction of the incident rays; and it is evident that in this position the equal beats of both cilia must result either in progressive or in retrogressive motion, parallel to the direction of the incident rays.

Thermotaxis.—Thermal stimulation also causes responsive movements towards or away from the source of stimulation; and these reactions, again, are found to change their signs, with varying intensities of stimulus. Thus, *Paramæcia* swim towards the warmer side of a vessel which is unequally heated, provided the temperature of the warmer side does not exceed 24° C. The response is in this case, then, seen to be positive; but when the temperature of the heated side is higher than 28° C. the *Paramæcia* are found to swim away, thus exhibiting a negative response.

Galvanotaxis.—Similar multiple response finds expression in certain *Infusoria*, in swimming movements of positive and negative character. Thus Verworn finds, for example, that under the excitation of an electrical current, *Polytoma* swims away from the kathode, and *Pleuronema* towards it.

In these galvanotactic movements, also, we meet with the same recurrent reversals with which we are already familiar in the case of the leaflets of *Desmodium*. In working with *Paramæcium*, Arthur W. Greely¹ found that after being subjected for about half an hour to a moderate current, the organisms which had previously gathered round the kathode reversed their action, and moved towards the anode, only to dart back immediately, again, towards the kathode.

I have demonstrated in Chapter XXXVI. the opposite responsive changes which occur under the action of acids and alkalis respectively. This explains the appropriate modification of galvanotactic response in *Paramæcium*, according as the organism has been reared in an acid or in

¹ Science has lost a very promising worker in the early death of this investigator. His experiments on *Paramæcium* are very valuable and suggestive.

an alkaline culture. Thus Greely has found that while alkali-reared *Paramaccia* invariably give the initial response by swimming towards the kathode, the reverse is generally the case with those which have been subjected to acid—that is to say, the latter as a rule begin by swimming towards the anode.

Chemotactic movements.—Similar effects are, again, observed under chemical stimulation. The opposite reactions of acids and alkalis which have already been described are the occasion of opposite chemotactic responses. Thus Jennings found *Paramaccia* moving towards, or showing positive reaction to, acids, whereas to alkalis they exhibit negative response, or movement away. Chemotactic reaction, again, is modified by the strength of the solution, that is to say by the intensity of stimulation. The opposite effects of strong and feeble doses (p. 488) are here illustrated by the fact that in many organisms positive response is observed under the action of a weak solution, and negative under a strong. Connected with the subject of chemotaxis is the interesting phenomenon of the response of the antherozoids of ferns and of *Selaginella* to malic acid, as discovered by Pfeffer. In the response of growth we found that dilute solutions of sugar gave rise to one kind of response, that is to say to acceleration of growth, and that with very strong solutions, say about 10 per cent., the opposite occurred—that is to say, retardation (p. 482). Now, it is found by Pfeffer that whereas the dilute solution of a malate exerted an attractive influence on the antherozoids, a 10 per cent. solution had a repellent effect.

SUMMARY

A rhythmic vegetable organ, in a state of standstill, has its autonomous movement renewed by a supply of energy from incident light.

Too strong an intensity of light may, by causing fatigue, arrest such movement. Or the greater fatigue of the more excitable half of the organ may cause a reversal of the relative rapidities of the up and down beats.

In *Desmodium*, under the continuous stimulation of strong light, these reversals are often recurrent. The downstroke, which is at first quicker, becomes less quick than the upstroke, and this may be again and again reversed.

In a ciliated organism the swimming movements are explicable by similar unequal up and down strokes of the anisotropic cilia. When the downstroke is quicker, the organism propels itself forward. When the upstroke is quicker, there is a movement backwards. Such swimming movements, due to multiple response, are initiated by stimuli of various forms. There are two natural types of these responses: positive movement, or swimming towards, and negative, or away from, stimulus. These are determined by the relative excitabilities of the upper and lower halves of the cilium.

Unilateral light exerts a directive action on responsive swimming movements, because the only stable position is one in which pairs of cilia are equally excited. The axis of the organism is thus orientated till parallel with incident light.

Strong stimulation of light, for reasons described, causes a reversal of the normal movement. Alternate periodic fatigue causes a responsive movement of the organism to and fro.

Under moderate unilateral thermal stimulus the organism exhibits a positive swimming movement, and under stronger a negative movement.

Similar responses to stimulus are exhibited under galvanic excitation. The normal response here also undergoes reversal under long-continued stimulation; since the actions of acids and alkalis are antagonistic, organisms reared under acid and alkali cultures tend to exhibit opposite reactions under galvanotaxis.

Under chemical stimulation, swimming organisms exhibit multiple responses. Acid and alkali, owing to their antagonistic actions, bring about opposite responses. The same reagent again occasions opposite responses, according to the amount of the dose. Thus antherozoids of ferns are attracted by the dilute solution of a malate, but stronger solutions exert a repellent action.

PART IX
GENERAL SURVEY AND CONCLUSION

CHAPTER L

REVIEW OF RESPONSE, SIMPLE AND MULTIPLE

Responsive contraction—Kunchanographic records—Direct and indirect effects of stimulation—Various forms of responsive expression; (*a*) Lateral motile response by differential contraction; (*b*) Suctional response; (*c*) Growth-response; (*d*) Torsional response; (*e*) Death response; (*f*) Thermographs of regional death; (*g*) Electrical response—Different types of response: (*a*) Uniform response; (*b*) Fatigue; (*c*) Staircase response—**Excitability**—Conductivity—Polar effects of currents—Multiple response—Continuity of multiple and autonomous responses—The ascent of sap.

WE have now studied in detail the manner in which a plant reacts to the varied forces of its environment, and although its response to them finds modes of expression which appear highly diverse, yet we have found that on analysis these are all reducible to two very simple and well-defined factors, of responsive contraction and expansion.

Responsive contraction.—In vegetable cells, as in other protoplasmic bodies, it has been shown that the impact of all external stimulus evokes responsive contraction; and this we found to be true, not in the so-called sensitive plants alone, but in all plants. Taking the simple case of a radial vegetable organ, such as a stem, style, stamen, or other filamentous structure, we find that it undergoes longitudinal contraction under stimulation. Here, then, we have a phenomenon which is analogous to the contraction of muscle. The amount of contraction of these ordinary vegetable organs, further, is sometimes very considerable, as we saw in the case of the coronal filament of *Passiflora*, where it was as great as 20 per cent. of the original length. Such responsive contraction takes place, moreover, under all forms of stimulation, mechanical, thermal, electrical, photic, and chemical; and we have found that all the various move-

ments of plants which are seen in nature, under the action of external stimulus, are but different expressions of a single fundamental response by contraction.

Kunchangraphic records.—By taking advantage of this responsive contraction, we are able to study all the physiological modifications induced in the vegetable tissue by various reagents, with as great ease and certainty as similar phenomena can be studied in animal muscle, using myographic records. By such study, again, we are once more led to see how misleading has been the superficial distinction between sensitive and non-sensitive plants, since the latter, or so-called ordinary, plants also exhibit contraction under stimulation.

Direct and indirect effects of stimulation.—The living organism is thus a delicately responding machine, whose responsive movements are brought about by external stimulus ; but this complex machinery has also the power of holding part of the energy of the external stimulating shock latent, for a longer or shorter time, so that part only may find immediate expression, while the rest is stored up as internal energy to be given out after the lapse of an intervening period. These two factors, of external stimulus and internal energy, again, induce opposite effects, of contraction and expansion respectively. And the infinite multiplicity of responsive processes in the life-cycle of the plant is brought about by their mutual play. That the combination of these two elements in varying degrees of each, finding expression in different ways, creates a tangle which would at first sight appear inextricable, can be easily understood. And it was the bewilderment which this fact imposed upon the observer, that drove us to postulate the existence of an unknown and indefinable vital force, whose mysterious working was to be held to account for the occurrence of all those phenomena that we were otherwise unable to explain.

It is possible, however, as we have found, going back step by step, to trace out the different expressions of these two distinct factors, of external stimulus and internal energy, and

to show, moreover, how the latter may be derived from the former. This may be clearly and easily seen by taking a simple case, in which we excite the stem by the application of external stimulus, on a zone a few centimetres below its upper end. As the direct effect of this stimulation, a contraction takes place in that zone. By this contraction an active expulsion of water, with local negative turgidity-variation, is brought about, and the expelled water is driven outwards in both directions from the excited zone. Following the course of the water which is thus forced upwards, we have found that it produces an increase of turgidity, or positive turgidity-variation, with consequent distension or expansion of all the cells above the stimulated area. Work is thus performed on these cells, in consequence of external stimulus, by which their latent energy is increased.

The energy of the stimulus applied in one has thus been conveyed to another region, hydraulically, there to give rise to an effect of increased turgidity and expansion, which was designated as the indirect effect. Thus the effect of external stimulus is seen to be twofold—namely, first by its direct action to induce local contraction, and secondly by its indirect effect, of increasing the internal energy, to bring about an expansion. The expressions of direct and indirect stimulation are thus seen to be opposite in character, and we have seen how they find opposite modes of expression in the case of each form of response.

Various forms of responsive expression.—The next question to be passed in review is that of the various modes in which the response of the plant was seen to find expression ; and here we found various responsive phenomena which are characteristic of life, and apparently entirely unrelated, to be ultimately dependent upon this fundamental inter-action between, on the one hand, the contraction due to external stimulus, and on the other the expansion due to internal energy.

(a) *Lateral motile response by differential contraction.*—Taking first the responsive mechanical movement of motile

Z Z

organs, we find that its gradual evolution can be traced from the simplest case, namely, the longitudinal response of a radial organ. In such a radial organ, if one side be rendered in any way the less excitable—say by the unilateral application of cold or anæsthetics, or by the fatigue induced by long-continued unilateral stimulation—we have an induced anisotropy. On now subjecting the organ to diffuse stimulation, the relatively more excited side will undergo the greater contraction, and the response will thus be by that movement which results from the concavity of the more excited. We find many instances again of the various stages through which this anisotropy passes before it culminates in the dorsi-ventral pulvinus; thus, for example, in a spirally formed tendril, where concavity has been induced by the unilateral excitation of that side, the concave surface is less excitable than the convex; and such a tendril, when diffusely excited by strong electrical stimulus, exhibits the excitatory effect by extraordinary writhing movements due to the relatively greater excitation and concavity of the originally convex side (p. 92). A plagiotropic stem, again, whose upper side is fatigued by the action of sunlight, exhibits on diffuse stimulation a downward movement, due to the greater excitatory contraction of the more excitable lower half (p. 86). The phenomenon of *differential* response, then, whose various preliminary stages we have thus traced, comes to its greatest perfection in the dorsi-ventral pulvinus of such plants as *Mimosa*, for we have found that in the last-named organ the characteristic responsive movement is not brought about by the action of excitable cells restricted to the lower half. That the upper half also is excitable is shown by the fact that on applying to it localised stimulus, say of light, its cells contract and raise the leaf (p. 631). The fall of the leaf, on the application of diffuse stimulation, is thus the result of the greater excitability of the lower. This fall, again, is not due to mere flaccidity caused by the expulsion of water from the excited organ, but to the actual differential contraction of the lower half, whose activity may

be gauged by the tension it can be made to exert on a spiral spring (p. 26). As regards mechanical response, then, a single law—that response is always by concavity of the more excited side—will be found universally applicable. In a dorsi-ventral organ, like the pulvinus of *Mimosa*, we have seen that response to diffuse stimulation is always by the contraction of the more excitable lower half. The same law, however, is also applicable even in the case of a radial organ excited unilaterally, for here the side acted on is relatively the more excited, and response is by concavity of that side.

A radial organ, acted upon from one side, undergoes concavity of that side, and consequent movement towards the stimulus. The same is true of pulvinated organs, when either the upper or lower half is acted upon locally by stimulus. As in radial organs, then, so also here, under these circumstances, we obtain instances of the directive action of stimulus ; but when stimulus is either internally or externally diffused, we obtain from a dorsi-ventral pulvinus the greater contraction of the more excitable half, and movement is thus made, for anatomical reasons, to occur in the direction at right angles to the plane which separates the two anisotropic halves.

Even in *Mimosa*, the contraction of the pulvinus itself is not very great, but the contractile movement is highly magnified by the attached petiolar index. When a radial organ is diffusely stimulated there is no lateral movement at all, and from this fact it has been erroneously inferred that ordinary plants are not sensitive. In fact, however, every plant is sensitive, and exhibits contractile response, which is shown, in the case of radial organs, by longitudinal contraction under diffuse stimulus, and by lateral response under unilateral stimulus.

The direct effect of stimulus on the pulvinus of *Mimosa*, causing a negative turgidity-variation of the organ, finds appropriate expression in the responsive movement of fall. But we have seen that the expression of the indirect effect of

Z Z 2

stimulus is opposite in character to that of the direct effect. The indirect effect of stimulus, or the increase of internal energy, thus results in an erectile response, as seen in the erection of the leaf in *Mimosa*, or *Biophytum*, when their internal energy is in any way enhanced, say by rise of temperature (p. 400). Taking all kinds of response, it will be found universally true that if the increase of internal energy give rise to one form of expression, the impact of external stimulus evokes the opposite.

(b) *Suctional response*.—It has been shown that contractile response gives rise to a forward impulsion of water; hence by the excitatory contraction of the root-cells the movement of water upwards is initiated. When such contractile movement is not single, but repeated or multiple, continuous propulsion of water is maintained. The rate of this propulsion therefore affords us a means of measuring the rhythmic activity of the plant-tissue.

(c) *Growth response*.—This pumping-in of water causes the transmission of energy to the distant growing region, and as by this the internal energy of the plant is increased, it finds expression there in a pulsatory expansion, which is the movement of growth. Following each pulse of expansion, there is a recovery which is incomplete, owing to fixation of growth-material. The resultant growth is thus the irreversible effect of the entire process. This growth-movement is another expression of that indirect effect of stimulation which we have already considered, by which a distant excited point gives rise to a progressive train of waves of positive turgidity-variation. The action of these waves may be seen not only in the movement of expansion at the growing point, but also by the erectile response of an intervening motile organ. This will be understood from the following diagram of an artificial plant (fig. 277), which shows how contractile action at the base, giving rise to an hydraulic wave, causes two different expressions of (a) motile response of the lateral organ, or leaf, and (b) growth-expansion of the terminal growing point. The pulvinus of this artificial motile organ consists of an

india-rubber tubing, the lower half of which is thinner, and therefore more expanding or responsive, than the upper. The upper end of the tube, representing the end of the plant, is closed over with a thin elastic strip of india-rubber. When now there is contractile action at the base, the pulse of increased hydraulic pressure thus induced is found to bring about a practically simultaneous erection of the artificial lateral leaf L, and an expansion or bulging outwards of the terminal yielding body G. The analogy in the case of the latter would be still more perfect if we imagined it covered, instead of with india-rubber, with some plastic substance which would set quickly on elongation or expansion, thus representing the permanent growth-effect. From this we see the connection between growth and those other responses with which we are already familiar. The only difference between the responsive expansion of pulvinated organs and this responsive expansion of growth lies in the fact that in the former recovery is perfect, and in the latter imperfect. It must also be borne in mind that growth may be initiated locally at the growing region if the sum total of energy, directly or indirectly supplied to it, be above par.

We further see in the case given that growth-response is not, strictly speaking, 'of its own accord' or spontaneous; for the energy of a definite stimulus, causing contractile movement at the base, is transmitted hydraulically, and performs the work of growth. It would be as accurate to describe the work done by hydraulic machinery as spontaneous, ignoring the energy that had set the pump in action, as to call growth

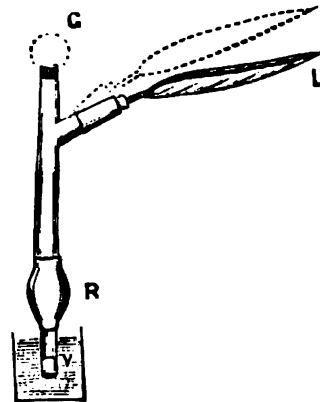

FIG. 277. Model of an Artificial Plant

Sudden compression of india-rubber bulb, R, causes hydraulic wave upwards, downward movement being prevented by valve V. This wave of increased pressure causes erection of the leaf, L, and the expansion of the terminal septum into G.

spontaneous, without recognising or tracing that energy which in the form of stimulus must have been supplied to some part of the plant machinery.

We have seen that a plant in a state of growth-standstill has its activity renewed when a stimulus is applied to the distant root, and that when the amount thus supplied is exhausted, the activity ceases. In growth, then, which is regarded as so characteristic a phenomenon of vital action, we see the law of the conservation of energy holding good, as in an ordinary inorganic system. The plant thus expresses the absorbed energy, by a responsive expansion, either of erection or of increased rate of growth, according to the particular organ of response which is concerned, both of these constituting cases of work done by internal energy, or indirect effect of stimulus ; but where the responding organ is directly excited by external stimulus, we obtain a contractile response of the organ, with expulsion of water, or negative turgidity-variation. The hydraulic current in our model is now reversed, and opposite responsive movements take place, by the fall of growth below the normal rate, and by depression of the leaf. If now we take a balanced record of growth, the impact of a uniform series of external stimuli will be found to give rise to a series of responses by depression of the rate, followed by recovery, exactly similar to those records of depressions of the leaf, with recoveries, which are obtained from pulvinate organs.

We may also see the expression of external stimulus and cessation of stimulus, in the appropriate periodic variations of growth, and movements of motile organs, which occur under the stimulating action of daylight, and the withdrawal of such stimulus at night. Thus in the daytime we see a response consisting of depression of the rate of growth, which corresponds to the depression of the leaf, say of *Mimosa*, and at night a recovery, or enhancement of growth, and erection of the motile organ. The daily periodic curves obtained of this growth-variation and responsive mechanical movement are very similar.

(*d*) *Torsional response*.—Another interesting type of response occurs when an anisotropic or dorsi-ventral organ is stimulated laterally. Under such conditions, a responsive torsion is induced, by which the less excitable side is made to face the external stimulus. The extent of the response depends on the intensity of stimulus, and the differential excitability of the anisotropic organ. In dorsi-ventral organs, the plane of anisotropy is fixed. But in certain climbing plants, this plane revolves in a positive or negative direction, and under the internal activity of growth, an autonomous torsional movement is thus observed. The opposition of the effects of internal energy and external stimulus is here seen, when such an organ is uni-laterally acted on, say by light. The autonomous torsional movement is then found to be retarded, or even reversed.

(*e*) *Death response*.—There is another curious phenomenon of response, which takes place at a certain definite point. When an organ is gradually raised in temperature, the internal energy is increased, and the organ exhibits a responsive expansion, if radial by elongation, or if pulvinated by erection; but when the death-point is reached, a sudden and irreversible molecular change takes place, attended by an excitatory contraction. In the curve of thermo-mechanical response we here find a sharply defined point of reversal, which affords us an exact index of the death-point. This death-point is very definite in plant-organs under normal conditions; in phanerogamous plants it is very near 60° C. Physiological modification of the tissue, moreover, may be gauged by the transposition of the otherwise definite death-point (p. 185).

(*f*) *Thermographs of regional death*.—Just as there is a definite point of reversal in the thermo-mechanical curve, so there is also a point of discoloration which is, under standard conditions, at a determinate interval from the death-point. A particular region, physiologically changed, may thus be thermally 'developed,' and made to exhibit as a thermograph, a picture of localised physiological variation (p. 184).

(g) *Electrical response*.—We have, lastly, to consider briefly the electrical mode of responsive expression. The excitatory contraction, with negative turgidity-variation, of a vegetable, as of an animal tissue, is accompanied by an electrical variation of galvanometric negativity. The indirect effect of stimulus with its positive turgidity-variation, moreover, has also a concomitant electrical expression of galvanometric positivity (p. 37).

Different types of response: (a) *Uniform response*.—

These various expressions of response are brought about by the fundamental molecular change induced by stimulus. When stimulus is moderate, and sufficient time allowed for recovery from molecular distortion to the original condition, a series of responses to uniform stimuli will be uniform; but if very strong stimulus be applied, recovery will only be completed after a long interval.

(b) *Fatigue*.—If successive stimuli be applied before complete recovery has taken place, the successive responses will exhibit diminution, or fatigue. Under strong and long-continued stimulation the plant-tissue exhibits, as in the case of tetanised muscle, a fatigue-reversal—that is to say, the contracted tissue passes into what is apparently its original expanded condition; but the difference between the normal condition and the condition of fatigue-reversal is seen in the fact that, while the former is sensitive to fresh stimulation, the latter is insensitive. The fatigued tissue, however, resumes its original excitability after a period of rest. This fatigue-reversal explains the erection of the *Mimosa* leaf under continuous stimulation (p. 110). We observe similar fatigue-reversals, even in inorganic substances like india-rubber, where the normal contraction under thermal stimulation passes into relaxation under the long-continued action of such stimulation; and the india-rubber becomes sensitive again only after a sufficient period of rest (p. 120). In connection with this, we sometimes meet with the very curious case of alternate or periodic fatigue, both in living and in inorganic substances. The simplest type of this

occurs when, under uniform stimuli, responses are alternately large and small. These alternations sometimes show themselves in groups. Under continuous stimulation, again, this periodic fatigue exhibits itself by response of an oscillatory character.

(c) *Staircase response*.—The tissue is sometimes in a relatively sluggish condition, and by the absorption of stimulus the molecular mobility is gradually increased. The effect of this is seen in the amplitude of successive responses, increasing in a staircase manner.

It is usually supposed that response is brought about by a chemical run-down of energy, of an explosive character. The external stimulus is thus supposed to act as it were on a trigger, to release the latent energy. The response is hence assumed to be disproportionately larger than the stimulus. That this cannot, however, hold good in all cases is clear; for the tissue is often found to absorb a certain proportion of the incident stimulus, the immediate expression of response being thus disproportionately smaller than stimulus. The energy of the system is now found, instead of being lowered, to be raised above par. The internal energy thus held latent is sometimes seen, as in the case of strongly stimulated *Biophytum*, to find expression later by multiple response. In the case of growth-response, again, it is a variable fraction of incident stimulus that finds immediate expression in the direct effect of retardation of growth, whereas the absorbed component gives rise to the subsequent responsive effect of an enhanced rate of growth. Referring to the former of these as the direct, and to the latter as the indirect, effect of stimulus, it is found that the sum of the two remains approximately constant. Below the optimum tonic condition it is found that the indirect effect is relatively the larger, but near the optimum this relation is reversed, and the direct effect is the larger. In a sub-tonic condition stimulus produces little or no direct effect, it being utilised to produce the indirect effect of enhanced growth. At the optimum, on the other

hand, practically the whole of the incident energy is expressed in direct response, there being little or no absorbed element (p. 460). A similar series of considerations may be applied to the response of mature pulvinated organs. In this case, however, the indirect effect of stimulus will find expression in an enhancement of the rate of recovery of the organ. It is, however, difficult always to discriminate with certainty between the natural and an enhanced rate of recovery; but on turning to growth-response we find that, by using the balanced method of record, it is easy to distinguish between the direct and indirect effects of stimulus, since these are here shown by curves in opposite directions. This method moreover affords us some means of measuring the relative magnitudes of the two factors in the response.

Excitability.—It is interesting to find that an agency which induces a variation of excitability produces a similar modification of all the different forms of response. In this way the long-continued application of cold has the effect of lessening excitability, and the response of a motile organ is thus found to be temporarily diminished or abolished. At the moment of application, however, owing to the fact that any sudden variation of environment acts as a stimulus, its effect is the induction of an excitatory movement. These phenomena are repeated with curious exactness in the case of suctional response. On the application of ice-cold water to the root, the immediate effect is a transient exaltation of suction, followed later by depression and arrest (p. 375). In growth-response, also, growth is diminished or arrested by this agency.

Another effect of the moderate application of cold is to induce a molecular sluggishness by which the latent period is increased. A moderate rise of temperature, on the other hand, increasing the molecular mobility, has the contrary effect, of reducing the latent period.

Anæsthetics, again, induce a diminution or abolition of excitability, as is seen by their effect on the various forms of response.

The excitability of a tissue which has not recovered fully from previous strong stimulation is found to be impaired. The fatigue-effect only disappears after the lapse of a period of rest. If, then, the resting intervals between successive stimuli be gradually shortened, the motile responses will be found to be progressively diminished, and a time arrives when the succeeding stimulus evokes no response, the tissue having become as it were refractory. The minimum interval during which the tissue remains thus irresponsive is known as the refractory period. In *Biophytum*, under normal conditions, this period is about ten seconds in duration (p. 273).

Conductivity.—It is usually supposed that the transmission of the excitatory effect, as seen in sensitive plants like *Mimosa*, is merely the transmission of a hydro-mechanical disturbance, and therefore unlike the transmission of the excitatory effect in animal tissues. It has, however, been shown that this is not the case, for here, as in the animal, transmission of excitation takes place by the propagation of protoplasmic changes. It was shown further that the hydrostatic disturbance was transmitted with a relatively great rapidity, whereas the true excitatory effect has a slower and definite velocity, characteristic of the particular specimen. This velocity, moreover, is found to be modified, and that in a manner precisely similar, by all those agencies which modify the velocity of transmission of excitation in animal tissues. Thus, cold, anæsthetics, and fatigue are all influences which reduce the velocity of transmission. As an example of this, we saw, in a certain specimen of *Biophytum*, in which the normal velocity was 3·8 mm. per second, that slight cooling reduced it to 1·3 mm. per second, or almost to one-third. Conversely, the raising of the temperature from 30° C. to 37° C. increased the velocity from 3·7 to 9·1 mm. per second. Strong stimulus is found to be conducted further and more rapidly than feeble or moderate. It is found in the case of animal tissues, again, that on account of its physiologically depressing effect, the anode acts as a block to the transmission of excitation; and the

same statement holds good in the case of the plant. The passage of mere hydro-mechanical disturbance could not have been affected in any way by the anode.

Nor is this transmission of excitation confined to sensitive plants alone. The fact that it occurs in all plants alike I have been able to demonstrate by various other methods, in using which we are rendered independent of the motile indications afforded by lateral leaflets. Thus by the Electrotactile Method we are enabled to detect, in any zone of the plant, the moment of arrival of the state of excitation from a distant point (p. 259). The Electromotive Method, again, displays the moment of arrival of the wave by the induced galvanometric negativity of the point (p. 261). The Chemical Method, again, shows the arrival of the wave of excitation by the projection of a dense precipitate, produced in a suitable solution (p. 255). All these different methods give us results which are in mutual agreement.

As showing how ill founded is the common distinction as between sensitive and ordinary plants, it was demonstrated that the velocity of transmission in some of the latter is greater than in the former. Thus in *Ficus religiosa* the velocity was determined at 9.4 mm. per second, whereas in the 'sensitive' *Neptunia oleracea* it was only 1.1 mm. per second. The velocity of transmission of the excitatory impulse in plants is found, again, to be of the same order of magnitude as in the nerves of lower animals (p. 252).

I have shown further that excitation is transmitted in the plant in both directions. It is, however, interesting to note that, generally speaking, the facility of this transmission is greater centrifugally—that is to say, in the direction of the ascent of sap—than centripetally. Thus, for example, in a petiole of *Biophytum*, while the centripetal velocity was 1.8 mm. per second, the centrifugal velocity was 3.27 mm. per second.

Since conduction of stimulus takes place by transmission of protoplasmic change, such change is naturally conducted

most easily along those paths in which there is most protoplasmic continuity. Parenchymatous tissues, in which the cells are divided from each other by more or less complete septa, are thus relatively inefficient as conductors of the excitatory effect to a distance. Hence, the lamina of the leaf does not transmit its local excitation to any distance; but tissues which contain fibro-vascular elements, and which are thus characterised by a greater protoplasmic continuity, are therefore better conductors of excitation. Thus stems, petioles, and peduncles are better conductors than the laminae of leaves, and parallel-veined leaves, again, are better in this respect than reticulated. As regards stems, petioles, and peduncles, moreover, the conducting power is greater longitudinally than transversely. In the peduncle of *Musa*, for example, I find the conductivity lengthwise to be three times as great as that crosswise. In consequence of this difference, it is found that the transmitted excitatory effect of a stimulus unilaterally applied is greater on the same than on the opposite side. This explains the appearance of responsive concavity at a distance from the point of stimulation, but on the same side.

It is to be remembered that, owing to the fact that this conduction of the effect of stimulus is an excitatory process, we find that in autumn and winter, when the physiological excitability is low, the conducting power of the tissue is also very much reduced.

Various degrees of conductivity are possessed by different tissues, and the distance to which the excitatory effect is conducted depends not only on the conducting power, but also on the strength and duration of stimulus. Thus, while in a feebly conducting tissue the effect of moderate stimulation is not transmitted to any distance, strong and long-continued stimulation is transmitted to a certain extent. Even in a better conducting tissue the excitatory effect of a moderate stimulus, on account of gradual enfeeblement, can only reach up to a certain distance. It is to be borne in mind that, while no tissue is absolutely non-conducting,

neither is any a perfect conductor, the difference between extreme examples being one only of degree.

The true excitatory effect, whether due to direct or transmitted excitation, consists, as has been shown, of contraction, with concomitant negative turgidity-variation. The result of this contraction and concomitant expulsion of water is, however, the sending out of a wave of positive turgidity-variation. Thus, up to the point reached by the true excitatory effect, we obtain contraction, with negative turgidity-variation; and beyond this point, a positive turgidity-variation, with consequent expansion. This latter effect we have designated as the indirect effect of stimulus. It is thus seen that, whereas the direct effect of unilateral stimulus is a concavity, its indirect effect is a convexity.

We have also seen that it is possible by electrical means to determine whether it is the direct or indirect effect of stimulus which has in any given instance reached a point from a distance; for the indirect effect of stimulus, with its positive turgidity-variation, is always attended by galvanometric positivity, whereas the true excitatory effect with its negative turgidity-variation is characterised by galvanometric negativity.

A tissue may conduct without exhibiting any motile indication of its state of excitation. With reference to this it is to be borne in mind that certain advantageous circumstances are necessary for the display of motile response; for since the fall of an excited leaf, such as that of *Mimosa*, takes place in consequence of the expulsion of water, it follows that when this is in any way impeded, as by over-turgidity of the tissue, there may be excitation without any responsive movement; for this reason, the leaflets of *Biophytum*, in the morning, when they are most tense, are not so sensitive as later in the day. Motile excitability is as a rule found to be abolished earlier than conductivity; hence a strong stimulus may be conducted through a region which exhibits, through narcotisation, no motile excitability (p. 229).

Polar effects of currents.—Another observation by which the fundamental identity of excitatory phenomena in

the animal and vegetable may be seen, lies in the respective effects induced at anode and kathode ; for example, employing the leaflets of *Biophytum* as experimental specimens, and using a moderate E.M.F., we find that the excitatory depression of the leaflets takes place at the kathode at make, and at the anode at break. The antagonistic effects of anode and kathode are further seen in the fact that while the kathode-make excites, the anode-make depresses. It is owing to this latter fact that an excitatory wave is blocked during transit at an anodic area (p. 233).

Another very interesting difference between anode and kathode, both at make and break, is seen in the fact that at make, while an induced contraction takes place at the kathode, an induced expansion occurs at the anode ; at break both these effects are reversed, there being now an expansion at the kathode, and contraction at the anode. Expansion at make, moreover, attains its maximum in a short time, while the kathodic contraction is relatively strong and persistent. These fundamental effects find appropriate expression in the response of growth. Thus, the unilateral application of the anode induces expansion, acceleration of growth, and resultant convexity, while the effect of the kathode is to induce contraction, retardation of growth, and resultant concavity (p. 558).

Owing to the fact that kathodic action is stronger than anodic, a feeble or moderate current flowing through the soil exerts a predominant excitatory action on the roots, by which the suctional activity of the plant is increased. The result is an increased rate of growth of the plant, which is independent of the direction of the current through the soil (p. 560).

The normal polar effects which have been described take place under the action of a moderate electromotive force. When this is excessively high, however, the normal effects are, or tend to be, reversed. In this reversal there appear to be two stages—the A stage and the B stage. In the A stage both anode and kathode excite at make ; but in the B stage,

under a still higher E.M.F., there is a complete reversal, inasmuch as the anode here excites at make, and the kathode at break. This reversal, further, is facilitated by fatigue of the tissue (p. 215).

These polar effects may also, as I have shown, be demonstrated in the case of animal tissues by means of the glow-response of the firefly. An excitatory reaction is here shown by an increase of the intensity of luminescence, and a depressing reaction by its diminution.

Multiple response.—When response is observed by means of the electromotive or electrotactile method, we obtain a single response to a single moderate stimulus; but on the application of strong stimulus a multiple series of responses is found to be evoked. In the case of the retina, similarly, a single intense stimulation by light gives rise to recurrent visual impulses.

In the same way, in the leaf of *Biophytum*, while a single moderate stimulus gives rise to a single mechanical response, a strong stimulus gives rise to a multiple series of responses. In this case certain other peculiarities may also be observed; for instance, a certain minimal intensity of stimulus induces the maximal mechanical response, which is not increased by any increase of intensity of the stimulus. The excess of such stimulus is held latent by the tissue for the time being, to find subsequent expression as rhythmic multiple response. These multiple responses are evoked by all forms of stimulation, mechanical, thermal, chemical, photic, and electrical. In this respect, of the minimally effective stimulus inducing maximal response, we have an important point of resemblance between the actions of a rhythmic plant-tissue and the cardiac muscle of the animal. Both, again, are characterised by the exhibition of a long refractory period, which is an expression of fatigue, or temporary loss of excitability after excitatory discharge. The periodic oscillation of excitability which is thus induced, imparts a rhythmic character to the mechanical expression of the excess of stimulus which is held latent in the tissue.

The sum total of the energy derived by the plant from the various stimuli of its environment determines what is known as its tonic condition.

Continuity of multiple and autonomous responses.—

There is no line of demarcation between the phenomena of multiple and autonomous response. When the latent or internal energy of the plant is above par, it finds expression in the form of multiple response, which is apparently automatic. Taking the typical case of a multiply-responding plant which is furnished by *Biophytum*, we find, on supplying it with excess of energy, by maintaining it at the temperature of say 35° C., and thus exalting its tonic condition, that it displays autonomous response. Conversely, when the tonic condition of an autonomously responding plant, such as *Desmodium*, is in any way reduced, by reason of low temperature, unfavourable season, or other circumstances, it becomes converted into an ordinarily-responding plant like *Biophytum*. A single moderate stimulus now gives rise to a single response, and a strong stimulus to multiple responses.

It is in accordance with this, that a *Desmodium* leaflet in a state of temporary standstill has its multiple or autonomous response renewed by any circumstance, or combination of circumstances, which sufficiently enhances the internal energy of the plant. Amongst such circumstances are: (1) The action of light; (2) favourable temperature; (3) the presence of stimulating chemical substances; (4) an increase of internal hydrostatic pressure.

The energy which expresses itself in pulsatory movements, then, may be derived by the plant either directly from immediate external sources; or from the excess of such energy already accumulated and held latent in the tissue, aided by the incidence of external stimulation; or from an excessive accumulation of such latent energy alone. Thus there is, strictly speaking, no such thing as automatism, for only when acted upon by stimulus can a living tissue give responsive indications. The impact of an external stimulus may give rise to immediate response, or it may be held

latent, in whole or in part, for subsequent expression. 'Inner stimuli' are simply external stimuli absorbed previously, and held latent. A plant or an animal is thus an accumulator, which is constantly storing up energy from external sources; and in the case of the plant, its suctional activity, determining the ascent of sap, its growth, and its spontaneous motile indications, are some of the principal forms in which this accumulated energy finds expression.

The ascent of sap.—The ascent of sap has been shown to be due to a multiple excitatory reaction of the plant-tissue, the movement of the water being a secondary effect of the rhythmic activity. The excitatory nature of the phenomenon has been demonstrated by the fact that various agencies which induce increase or diminution of excitability, have also the effect of bringing about an enhanced or diminished rate of suction, above or below the normal. The effects induced by these agencies, together with their time-relations, can be easily and accurately recorded, as has been shown, by means of the *Balanced Shoshungraph*. The transient excitation due to a sudden application of cold, and the abolition of excitation under its prolonged application, are seen in a transient enhancement of suction, followed by arrest. The excitatory effect of the application of hot water, again, is shown by an enhanced rate of suction. Poisonous chemical reagents arrest suction quickly in specimens where, owing to a less favourable tonic condition, the power of resistance is low, and slowly in other cases. As the tissue of the plant exhibits this suctional activity throughout its length, the local death of a given portion, by scalding or by poison, would not necessarily arrest the suction of the entire plant. Such an arrest can only occur definitely when the entire plant is killed.

The internal energy, on which the activity of suction depends, may fall so much below par as to bring it to a standstill; but the activity is renewed on the application of fresh stimulus.

That the ascent of sap is not fundamentally due to

transpiration from the leaves is seen from the fact that in a saturated atmosphere it continues to take place. That it is not, again, fundamentally due to the osmotic action of the concentrated cell sap in the leaves is seen from the fact that the ascent continues to take place on the removal of leaves. It is seen again from the further fact that under favourable circumstances, on the application of an osmotically strong solution of sodium chloride to the root, the cell sap, instead of being withdrawn by osmotic action, is made, by the excitatory effect of the salt, to ascend more vigorously.

The ascent of sap is thus an excitatory phenomenon, and its uni-directioned flow is due to the graduated passage from point to point of the co-ordinated excitatory reaction, propelling water forward. This rhythmic excitation is initiated in the intact plant at its root, by the stimulus of contact with soil, the friction of the growing organ against rough surfaces, the excessive turgidity caused by the absorption of water, and possibly by the chemical stimulus of substances present in the soil. In the case of cut branches placed in water, the excessive turgidity at the cut end initiates rhythmic activity, which drives the water upwards; but if such a branch be placed upside down, with its foliage in water, the now turgid anatomically upper end becomes the seat of excitation, and the direction of the flow of sap is reversed.

The connection between the conduction of stimulus and conduction of water is seen from the fact that the movement of water takes place preferentially along those channels which are also good conductors of excitation. Hence it is transported more easily along the plant than across it; and while the movement is possible either upwards or downwards, yet it is quicker in the upward direction, which is also preferentially the direction of conduction of stimulus.

The same movement of water which is produced by the co-ordinated rhythmic activity of cells throughout the plant appears either as suctional or as pressure movement, according to the point of view which we adopt. When the removal

of water from the plant is in any way arrested, a positive pressure is produced, owing to its excessive accumulation. Similarly, when loss is greater than supply, the pressure will be negative. The ascent of sap, primarily due to cellular activity, may be secondarily aided by evaporation from the leaves, and by the osmotic action of the concentrated cell sap there. Owing to the distribution of unequally active cells, an irregular variation of pressure may be induced in the stem. The excitatory movement may be transmitted to a distance by conduction, or there may be conduction by 'relays.' An isolated mass of highly excitable tissue may thus be excited *de novo*. The excretion of water and of nectar are phenomena of cellular activity, analogous to that which brings about the ascent of sap. The translocation of food-material is also probably due, at least in part, to excitatory reaction.

The internal activity of the plant, causing increase of turgidity, may be detected mechanically by that erection of the leaf which is characteristic of the positive turgidity-variation. Any increase of internal activity is exhibited in dorsi-ventral organs, such as the petioles of *Mimosa*, *Biophytum*, and *Artocarpus*, by the erection of the leaf. Thus, when the internal energy of the plant is increased by a rise of temperature, the leaves become erected. Conversely, under the action of cold, on account of the diminution of the latent energy, the opposite effect, or droop, is induced. This explains the drooping of various leaves during frost, and their subsequent erection, when brought into a warmer atmosphere.

CHAPTER LI

RESPONSIVE GROWTH-CURVATURES IN PLANTS

Longitudinal growth and its variations—Effect of temperature on growth—Responsive growth-curvature under unilateral stimulation :— 1. Direct unilateral stimulus on the responding organ : (a) Positive response under moderate stimulation ; (b) Intermediate or neutral response ; (c) Negative response ; (d) Dorsi-ventral positive response ; (e) Dorsi-ventral response which may become negative — 2. Indirect effect of unilateral stimulation : (a) Negative response ; (b) Positive response—Responsive action under stimulus of gravity—Heliotropic action in radial organs—Heliotropic action in plagiotropic and dorsi-ventral organs—Phototactic movements—Nyctitropic movements.

WE shall next pass in review the responsive growth-curvatures induced in plants by various agencies, and shall then in the following chapter consider at some length the extended range of those similarities which exist as between the physiological responses of plant and of animal tissues.

Longitudinal growth and its variations.—It was shown by means of the highly magnified continuous record which was obtained with the ordinary and Balanced Crescographs, that growth was a phenomenon of multiple response ; and it was further shown that these multiple responses of growth exhibited the same characteristics as had previously been observed in the multiple motile responses of *Biophytum* and *Desmodium*. Each of the constituent responses consisted of a sudden elongation due to a pulse of increased turgidity, followed by an incomplete recovery. The irreversible growth-effect consisted of the difference between this elongation and its recovery. These pulses of positive turgidity-variation were mainly due to excitatory reactions occurring about the zone of growth, which delivered from within, upon

the plastic material of that zone, repeated hydrostatic blows. The consequent expansive response was thus the indirect effect of stimulation.

It is thus the internal energy, ultimately derived from external stimulus, that gives rise to those rhythmic activities by which the pulsations of growth are maintained. When the sum total of the latent stimulating factors that determine the tonic condition is below par, there is an arrest of the multiple response of growth, corresponding to the similar arrest of multiple motile response in *Desmodium*. In a plant in which growth is at standstill, it may be renewed by a fresh supply of energy. Thus, if hot water be applied to the root of such a plant, energy is hydraulically transmitted to the growing region, and there re-initiates growth.

If moderate stimulus be thus imparted, the responsive growth-movement persists for a short time, and then comes to a standstill, to be again renewed by a fresh supply. Again, the movement of growth being due to the indirect effect of stimulus, we might renew or accelerate it by applying stimulus, say, on the stem or its top, at such a distance from the growing region that the direct excitatory effect would not be transmitted to it. Stimulus applied directly on the growing region would, however, by its true excitatory effect, induce contraction and retardation of growth.

The longitudinal growth thus described takes place in a strictly radial organ. If the organ, however, be bilateral, instead of radial, it will exhibit lateral oscillation, owing to the alternate growth of the two sides. Or growth may proceed in a spiral line, giving rise to circular or elliptical movements. A very good example of the last is afforded by the torsional growth-movements of climbing plants. These various circummutating autonomous movements of growth, passing from regular movements in a circle, through ellipses, to a straight line, are exactly paralleled by different examples of autonomous mechanical responses in *Desmodium*, where also we find circular, elliptical, and rectilinear movements.

Effect of temperature on growth.—That growth is an excitatory phenomenon is seen, again, in the fact that it is increased by any circumstance that tends to increase excitability. Thus, for example, in the case of most tropical phanerogamous plants, it is found that responsive excitatory contraction is greatest at a temperature of about 35° C. ; and this is also found to be the optimum temperature, at which the natural rate of growth is at its maximum.

I have described a method of obtaining a THERMO-CRESCENT CURVE for the determination of the various rates of growth which correspond to different temperatures. The continuous record thus obtained in the course of about half an hour affords us not only the rate of growth at any temperature, but also a means of determining its optimum and maximum points. The optimum temperature may also be determined, with an accuracy within one-tenth of a degree, by means of the Balanced Crescographic record. The results obtained by all the different methods employed are found to concur. The optimum point is thus shown, under normal conditions, to be very constant (p. 451). It may be said here that in the case also of plants which exhibit torsional growth-response, the rate of torsional movement is greatest at this optimum point.

The arrest of growth which occurs at the maximum temperature does not appear to be due to any cessation of activity as brought on by rigor ; for we found in a record taken from a seedling of *Balsam* at 44° C. that at this temperature the constituent growth-pulsations had actually become more frequent than before, the resultant abolition of growth being due to the fact that response and recovery were now equal. It was likewise shown that the apparent arrest of the pulsatory movements of *Desmodium* at certain high temperatures was not due to the cessation of activity, but that at such temperatures the pulsations had become more frequent and very minute (p. 431). The fact that at the maximum temperature growth is not arrested by rigor receives curious illustration, again, when the application of

doses of poison at such a temperature brings about, at least temporarily, a renewal of resultant growth (p. 487).

Another important point in the effect of temperature has already been alluded to. It has been shown that a plant below the optimum temperature, being in proportionately sub-tonic condition, will to a very great extent, or even entirely, hold the incident stimulus latent, thus increasing its own latent energy. In this sub-tonic condition, then, the stimulus induces little direct contractile effect, but is utilised to induce the indirect acceleration of growth. At the optimum temperature, however, almost the whole of the incident stimulus finds expression in direct contractile response, there being now little or no absorbed component; and beyond the optimum, the tissue not only possesses little or no power of holding stimulus latent, but its receptivity also appears to undergo great diminution (p. 461).

Responsive growth-curvature under unilateral stimulation.—I have shown that the response of a growing is not essentially different from that of a pulvinated organ. The direct effect of unilateral stimulation gives rise in both cases alike to negative turgidity-variation, with consequent concavity of the side acted upon; and the indirect effect, on the other hand, consequent on the unilateral stimulation of a distant point, gives rise, in both cases alike, to a positive turgidity-variation, or convexity of the same side of the responding region. This fact was demonstrated in the case of *Mimosa* by applying stimulus: (1) near the motile organ, in which case we obtained the direct effect by fall of the leaf; and (2) at a considerable distance, when the indirect effect gave rise to the erection of the leaf (p. 531). It was found, however, that when the stimulus applied at a distance was very strong and long-continued, true excitation was ultimately transmitted by conduction, inducing excitatory contraction, with fall of the leaf.

In growth-curvatures, similarly, we obtain responsive movements appropriately due either to the direct or indirect

effect of stimulus. These have been shown to be classified as follows :

I. Direct unilateral stimulus on the responding organ : (a) *Positive response under moderate stimulation.*—The proximal, by the direct action of stimulus, contracted ; and the distal, by the indirect action of stimulus, expanded. The result was a concavity of the proximal, and convexity of the distal, conspiring to bring about movement towards stimulus.

(b) *Intermediate or neutral response.*—Though the transverse conductivity of a tissue may be feeble, yet under somewhat strong stimulation the true excitatory effect is transversely conducted from proximal to distal. The result is that when the two opposite sides are equally excited, there is a neutralisation, or disappearance of responsive curvature ; or, by alternate fatigue of the two sides again, the organ may be made to oscillate to and fro about a more or less mean position.

(c) *Negative response.*—When stimulus is very strong and long continued, we obtain not only the transverse conduction of effect, but also temporary induction of anisotropy of the organ. The proximal side is now, owing to fatigue brought about by the direct impact of excessive stimulus, the less excitable ; and the internally diffused stimulus, causing greater contraction of the more excitable, induces concavity of the distal, or a negative responsive movement.

Besides this we have organs which are characterised by a permanent anisotropy or dorsi-ventrality, and we then obtain two classes of effects, according as the transverse conductivity is very feeble or moderately strong. Owing to the dorsi-ventral structure, the responsive movement can only take place at right angles to the plane which separates the anisotropic halves of the organ. These effects are the same in growing organs, such as plagiotropic shoots and dorsi-ventral petioles, and in mature dorsi-ventral organs, such as pulvini.

(d) *Dorsi-ventral positive response.*—When the transverse

conductivity is feeble, the stimulus remains localised on the side of the organ acted upon. Thus the stimulation of either upper or lower side induces a positive response, or movement towards stimulus.

(e) *Dorsi-ventral response which may become negative.*—

When the transverse conductivity of the organ is considerable, and the excitability of the lower half relatively great, then the strong stimulation of the upper side will, by internal diffusion, cause contraction in, and concavity of, the more excitable lower. The responsive movement will then be negative, or away from stimulus; but feeble or moderate stimulation of the upper half, not being transmitted to the lower half, causes a positive response. Direct excitation of the more excitable lower half will always give rise to a movement towards stimulus, or positive response.

2. **Indirect effect of unilateral stimulation:** (a)

Negative response.—When moderate stimulus is unilaterally applied at a distance from the responding organ, it is the indirect effect that is transmitted to that region, causing convexity of the same side, with consequent movement away from stimulus, or negative response. This is very well illustrated when the tip of either shoot or root is subjected to moderate unilateral stimulation.

(b) *Positive response.*—But when the unilateral stimulus at the distant point is strong or long continued, the excitatory effect is transmitted by conduction, and induces a contraction and concavity of the same side, resulting in a movement towards stimulus, or positive response.

From what has been said it will be understood that moderate unilateral stimulation of the tip of root or shoot induces negative, and excessive stimulation positive, while between these two extreme cases there may be intermediate or neutral, response of the responding region.

These effects are induced by stimulation of all forms, and it is thus clear that there is no specific sensitiveness of the dorsi-ventral as distinguished from the radial organ, nor is there any polar difference between the response of root or

shoot, the tips of both organs behaving alike. The one universal law which applies in every case is, that the direct effect of stimulus is to induce contraction, and its indirect effect to cause expansion.

On taking a general survey of the responsive movements which are induced by the unilateral action of stimulus, we find that moderate stimulation of the growing region induces a positive movement. Or negative movement, again, may be induced in either of two ways—that is to say, by moderate stimulation of the tip, or by very strong stimulation of the growing region.

Responsive action under stimulus of gravity.—I have shown that the unilateral application of pressure of particles is efficient to cause responsive contraction. An experiment was described in which it was shown that the unilateral pressure of magnetically attracted particles would induce concavity of the side acted on (p. 497). The weight of statolithic particles may thus be the efficient cause of stimulation by gravity. It is to be borne in mind, however, that stimulation caused by such means as the weight-effect of these minute particles can only be moderate. We have therefore in the case of geotropic stimulation to deal only with the direct and indirect effects of unilateral stimulus of moderate intensity. In the case of the stem the growing region is directly stimulated. A horizontally laid stem thus curves upwards to meet the lines of force, or rays of gravity, just as it would bend upwards under heliotropic action to meet the rays of incident light. It is supposed that the curvature of the stem under gravity is mainly due to an active growth of the convex side; but I have shown that it is due, on the contrary, to an excitatory response, which consists, like all other forms of response to external stimulus, of a contraction. The active element in the induced responsive curvature is thus the contraction of the upper side of the organ, aided subsidiarily by that expansion of the under side which is brought about by the indirect effect of stimulus on the distal. That this is the case is seen

from the fact that, on localised cooling of the upper side, the movement of the organ in response to gravity is abolished, whereas cooling of the lower side has little or no effect on the responsive movement. This experiment incidentally supports the view that it is the inner tangential wall of the cells which is relatively effective in responding to the stimulus of gravity. In turning to the geotropic response of the root, on the other hand, we find that it is the distant tip which is the perceptive region for gravitational stimulus. Hence it is only the indirect effect of stimulus which acts on the responding growing region. But we have seen that moderate stimulation of the tip, by any form of stimulus whatsoever, always induces a movement at the responding region, of opposite sign to that which is the result of direct stimulation, and from this the opposite geotropic responses of shoot and root follow as a matter of course. This fact entirely negatives the assumption that shoot and root are possessed of any polar difference of sensibility, or that any specific geotropic sensibility has been evolved in the radicle for the advantage of the plant.

Heliotropic action in radial organs.—We shall find similarly, in studying the various movements of the plant in response to heliotropic stimulus, that, diverse as they seem, they are characterised by an underlying unity, being in fact but so many expressions of the universal law that response takes place by the contraction and concavity of the more excited.

The fundamental effect of light was demonstrated by showing that, in a growing organ, diffuse stimulation induces a contraction and retardation of the rate of growth. This was also shown to be true of all other forms of stimulation, including those of thermal and electrical radiation. The incidence of radiation may, it is true, cause a rise of temperature; and this would, as we know, have the effect of enhancing the rate of growth. In order, therefore, to discriminate the effect of radiation as such from that of temperature, an experiment was described in which the circumstances were so arranged that no rise of temperature

could take place while the effect induced by radiation as such was being observed. Under these crucial conditions it was demonstrated that the effect of radiation is to induce responsive contraction.

Under moderate unilateral stimulus of light, as in the case of gravity, two definite and distinct effects were observed, according as stimulus was applied directly on the responding region or on the distant tip. In the former case we obtained a positive, and in the latter a negative, responsive movement. Up to this point, then, the actions of light and of gravitation are parallel in their effects—that is to say, the positive heliotropic movement of the stem corresponds to the so-called negative geotropic movement of the same organ ; and the negative heliotropic movement of the root to its so-called positive geotropic. Looked at in relation to the direction of stimulus, however, it may be said that the response which is commonly known as ‘negative geotropic’ is actually positive, and *vice versa* ; for, accepting the theory of statolithic or hydrostatic pressure as to the effective cause of stimulation, the direction of the excitatory pressure is in the direction of the lines of force of gravity. In a stem laid horizontally, then, and acted on by vertical lines of gravitational force, or by vertical rays of light, we obtain the same directive response to these similar directive stimuli, by the bending upwards of the organ to meet the rays, or the lines of force. Some confusion is therefore inevitable when one of these responses is designated as positive, and the other as negative, for the essential similarity of the two is here masked by the use of directly opposite terms. This difficulty might perhaps be overcome by naming the normal responsive movement of the stem as *positive phototropic* and *positive gravitropic*, or *pro-gravitropic*, and that of the root as *negative phototropic* and *negative gravitropic* or *anti-gravitropic*.

We next turn to the differences between the effects of heliotropic and geotropic action. Such differences arise from the two facts that : (1) only in the root is the region of the perception of gravitational stimulus separated from that of response ;

and that (2) geotropic stimulus is always of moderate intensity. As regards the first of these two differences, it has been shown that, on applying unilateral heliotropic stimulus of moderate intensity to the tip of the shoot, we obtained the same negative response of indirect stimulation as is given by the root-tip. In the case of geotropic stimulus, however, there can be no phenomenon corresponding to this, inasmuch as in the stem the statolithic particles appear to be diffused, instead of being localised at the tip. The second point of difference between the two responses arises from the fact that heliotropic stimulus may be of any degree of intensity. Hence the direct excitatory effect of strong unilateral stimulation of the root-tip may in the case of light be transmitted to the growing region, and there induce a positive response, or movement towards stimulus. This accounts for the fact that while roots in general give one kind of gravitational response of so-called positive sign (but really negative), some roots give negative response to light, and others positive.

Turning next to the direct action of unilateral heliotropic stimulus on the growing region, we find, as explained in the summary of responsive action in general (p. 535), that the effect is modified by the intensity of stimulus, by the transverse conductivity of the organ, and by its existing anisotropy. Thus in the case of a radial organ, such as the hypocotyl of *Sinapis*, moderate stimulus, its effect remaining localised on the proximal side, has been shown to evoke a positive responsive movement. Stronger or long-continued stimulus, reaching the distal side by transverse conduction, neutralises this first effect, and the organ thus remains at right angles to the incident light, or in a dia-heliotropic position, apparently unaffected by it. In other instances, again, owing to the alternate excitation of the two sides, the organ may oscillate to and fro about a mean position. With still stronger stimulus, however, an anisotropy is induced, by which the proximal side becomes, through fatigue, the less excitable, and the internally diffused stimulus causes greater contraction and resultant concavity of the distal side ; that is

to say, a negative response. It was thus made clear that the three types of response—positive, negative, and dia-heliotropic—are not due to three different specific sensibilities.

It has been pointed out, further, that these considerations explain why it happens in many cases that, while moderate stimulation induces a considerable responsive movement, stronger stimulation, instead of increasing this, actually neutralises it. It is due, as we have seen, to the transverse conduction of stimulus by the tissue, that the positive effect is counteracted or reversed. This explanation has been shown to account satisfactorily for various cases apparently anomalous,

Certain tendrils are regarded as heliotropically insensitive. For example, the tendril of *Passiflora* when acted on by sunlight shows little or no responsive movement. On artificially diminishing the transverse conduction, however, by the application of cold, I have shown that it exhibits the ordinary positive responsive movement. The tendril of *Vitis*, again, which is supposed to be endowed with a specific sensibility of negative character, has also been shown to exhibit the normal positive response under light of moderate intensity. The modifications of transverse conductivity which are brought about by age and season, with their consequent appropriate variations of response, are seen in *Tropæolum*. A very young tissue, as a general rule, owing to the fact that the fibro-vascular elements are not fully developed, is a bad conductor of stimulus, which therefore remains localised at the point of application. Hence young plants exhibit movements of positive response, whereas older plants, owing to transverse conduction, with its effect of neutralisation, appear to be little affected by light. In connection with this it must also be borne in mind that the power of contraction declines with age. The characteristic effect of season, again, results from the fact that the conducting power of a tissue is at its feeblest in autumn and winter, and correspondingly greater in spring and summer. In autumn, therefore, stimulus remains localised, and *Tropæolum* and Ivy during that season respond to heliotropic

stimulus by positive curvature ; whereas in summer strong unilateral stimulation is transversely conducted, and induces negative responsive curvature.

Heliotropic response in plagiotropic and dorsi-ventral organs.—We have seen that negative response is brought about in a radial organ by induced anisotropy, and transverse conduction of stimulus. Effects fundamentally similar are seen in organs which are characterised by a natural anisotropy. A connecting link between this transient induced anisotropy of radial organs, and the permanent anisotropy of a dorsi-ventral pulvinus, is afforded by plagiotropic stems, in which anisotropy has become more or less permanent, owing to the long-continued unilateral action of vertical light. Two different types of response are exhibited by anisotropic organs, depending on their transverse conductivity and on the relative excitabilities of their two sides. In the first of these, transverse conductivity being feeble, vertical illumination remains localised, and induces positive response. This is the true explanation of the so-called diurnal sleep, with upward folding of the leaflets, of *Robinia*, *Erythrina indica*, and *Clitoria ternatea* (p. 629). In the second type, the stimulus of vertical illumination is transmitted to the more excitable distal side, inducing concavity of that side, and consequent negative response. The different stages of this effect are well seen in *Mimosa*, when the stimulus of light acts on the dorsal or upper side of the pulvinus. Here the immediate effect is a positive response or erection of the leaf ; and as the stimulus percolates to the distal side, this effect is neutralised and converted into an increasingly negative response. The greatest degree of negativity or fall in nature is thus attained by the cumulative action of the whole day's illumination. Such is the response which is characteristic of the second type. The action of strong vertical light in such cases induces movement downwards. And this is seen in plagiotropic stems like those of *Cucurbita* and *Ipomœa* ; in the thallus of *Marchantia*, and the midribs of various leaves ; and in the so-called diurnal sleep, with downward folding of the

leaflets, of such leaves as those of *Oxalis*, *Biophytum*, and *Averrhoa*. In the heliotropic responses of ordinary leaves, again, we have exactly similar classes of phenomena. In these cases it has been shown that there is no specific dia-heliotropic sensitiveness, such as that by which the upper surface of the leaf was supposed to place itself at right angles to the light, for the purpose of absorbing the largest possible amount of stimulus. It was shown, moreover, that with regard to that response by which the ultimate position of the leaf is determined, the lamina was not the perceptive organ. In ordinary, as in pulvinate, leaves we find response to be of two extreme types, connected by innumerable gradations. First, we have leaves like that of *Mangifera indica*, in which on account of the feeble conductivity of the pulvinoid vertical illumination induces a positive response, or movement upwards; and as an example of the second type we saw that negative response, or movement downwards, was given by the leaf of *Artocarpus* under vertical light. These responsive movements induced by light, although, generally speaking, predominant, are modified by the presence of other subsidiary factors, which all contribute in various degrees to bring about the variety of attitudes ultimately assumed by the leaves. These subsidiary factors were enumerated as: (1) the epinastic or hyponastic tendency; (2) the general turgescence condition of the plant; (3) the characteristic limits of flexibility of the motile organ; and (4) the differential geotropic excitability of the organ. When a petiole is acted on laterally by light a torsion is induced, by which the upper surface of the leaf is made to face the incident stimulus. It has been shown that this movement is not due to any specific dia-heliotropic sensibility; for any form of lateral stimulation, say chemical or thermal, will induce a similar response by torsion, the result being always that the less excitable surface is made to face the stimulus. Similar effects are also observed in compound strips made of such unequally contractile substances as ebonite and india-rubber.

The fact that it is the differential excitability of the organ which under lateral stimulation causes this torsional movement was further demonstrated, when the difference was artificially increased by the local application of chloroform to the upper half of the pulvinus. The torsional response was then found to take place, with a corresponding enhancement of rate, in the same direction as before. But when this natural difference of excitability was reversed, by the abolition through local application of chloroform of the excitability of the lower half of the pulvinus, the direction of the responsive torsion was found to undergo reversal.

By carrying out a similar series of experiments, with special reference to the lateral action of gravitational stimulus on a dorsi-ventral organ, it was shown that such an organ as a whole exhibited neither a positive nor a negative, but a differential geotropic action. The investigation showed that the upper half of a pulvinus was less excitable than the lower half under geotropic stimulus. An artificial increase of the existing difference between the excitabilities of the two halves enhanced the rate of the normal torsional response, and the reversal of these natural excitabilities reversed the direction of the torsional response to geotropic stimulus (p. 664).

Phototactic movements.—A leaflet of *Desmodium* in a state of standstill resumes its pulsatory beats when stimulated by light. Owing to the anisotropy of the motile organs, one half of the beat is more rapid than the other. Too strong an intensity of light, however, by causing greater fatigue of the more excitable half of the organ, may cause a reversal of the relative rapidities of the up and down beats. In *Desmodium*, under the continuous stimulation of strong light, these reversals are often recurrent. The downstroke, which was at first the quicker, becomes less quick than the upstroke, and this reversal may take place again and again, in alternation with its opposite. These effects, seen in a pair of anisotropic motile organs in *Desmodium*, afford an explanation of the swimming movements of certain ciliated

organisms. These swimming movements are brought about by the rhythmic beats of the anisotropic cilia under unilateral stimulus of light, either the up or down stroke of each such beat being relatively quicker than the other. For reasons which have been explained, moderate stimulation, initiating these rhythmic responses, causes movement in one direction, and stronger stimulation movement in the opposite direction ; or, as in the case of *Desmodium* leaflets, there may be recurrent reversals, causing alternate progressions or retrogressions to and fro. Similar forms of response with similar variations are brought about by forms of stimulation other than light ; there are thus thermotactic, galvanotactic, and chemotactic swimming movements.

Nyctitropic movement.—The nyctitropic movement has been shown to be the result of heliotropic action, the fall of the leaf of *Mimosa* at evening being due not to the action of on-coming darkness, but to the cumulative stimulus of the whole day's illumination. Taking this plant as the type, it was shown that the diurnal movement was caused by the action of two different periodic factors, namely: (1) the differential effect of light on the pulvinus itself during the day, alternating with the cessation of stimulus at night ; and (2) a periodic inflow and outflow of water, which takes place in the plant as a whole by the recurrent action of light and darkness. By the first of these factors the leaf is progressively depressed during the day, the reverse process taking place during the night, as a result of natural recovery, aided by the conserved internal energy which gives an impulse opposite to that of external stimulus. These two periodic factors, of the effect on the pulvinus itself, and of that on the plant as a whole, act concordantly, and give rise to periodic movements of the leaf which are of large amplitude. Such forced diurnal vibrations, by long repetition, give rise to periodic after-effects which persist for a time, even on the cessation of the periodically exciting cause.

CHAPTER LII

ON PHYSIOLOGICAL RESPONSE, AND ITS CONTINUITY IN PLANT AND ANIMAL

Vitalism—Fundamental unity of physiological response in plant and animal—
Theory of Darwin—Variation as induced by external forces.

WE have reviewed, in the last two chapters, the various phenomena of plant response. We shall now turn our attention to the consideration of irritability, or the capacity of responding to stimulus, in general.

Vitalism.—We have seen that when a tissue is rendered molecularly sluggish by any physical means, such as cooling, its irritability is found to be temporarily abolished. Irritability is thus ultimately due to molecular responsiveness, and excitatory response is brought about by the molecular derangement consequent on stimulus, with the subsequent self-recovery. We have seen further that the state of excitation is exhibited, either by a mechanical or by the electrical mode of response, and that even where mechanical indications are not available, the electrical sign of excitation is unailing. We have also seen briefly in the course of the present work, and I have demonstrated in full elsewhere,¹ the fact that similar excitatory response is given, even by inorganic matter, under stimulation; and in such cases also we have been able to observe and record not only the phenomenon of response itself, but also its numerous appropriate modifications under varying conditions. Thus fatigue brings about diminution of inorganic, as of organic response. Amongst chemical reagents, again, some induce exaltation and others depression; and many so-called poisons act here, as in the case

¹ Bose, *Response in the Living and Non-Living*, 1902.

of the plant or animal, by inducing the abolition of response. Irritability or molecular responsiveness, therefore, must be regarded not as characteristic of organic substances alone, but as the universal property of matter. In the case of what is commonly known as the living, we have merely higher complexities, with greater instabilities, of molecular structure. External stimulus is here liable to induce greater derangement, and the irreversible molecular change known as death takes place the more easily, the more highly organised the complexus may be. Bacteria, for example, will survive conditions which would immediately prove fatal to more complex organisms.

In studying the responsive phenomena of living organisms, therefore, we must fix our attention on their molecular aspect, and try to follow out the physico-chemical changes which are consequent on the molecular derangement induced by stimulus ; and we are more likely to succeed in obtaining a growing insight into the various phenomena of life, when we approach the subject from this point of view, than when we permit ourselves to evade each difficulty as it arises by referring it to the inexplicable action of a mystical vital force. Physical and mechanical considerations at first appear to us to be inadequate to the explanation of the complex movements of the living machine, just as the similarly complex movements of a wind-motor, connected with a hidden electrical apparatus, would at first sight be inexplicable to an inexperienced observer (fig. 278). Let such an observer be brought face to face for the first time with such a windmill. Its movements under the action of wind will arouse his wonder, and this will be increased when sometimes even in the absence of wind he sees the vanes revolving still, but now in an opposite direction. He may again notice oscillatory rotations, now in one way and then in the other. Failing to find any rational explanation of these movements in this first stage of his inquiry, he will be driven to attribute them to an unknown power, whose characteristic it is to manifest itself by such erratic actions,

now in one direction and again in the opposite, and whose mystery lies mainly in this caprice.

But the observer, in the course of his further inquiry, finds that the vanes, whose rotation under the impact of the external stimulus of wind first attracted his attention, are but a part of a complex machine, the interior of which had

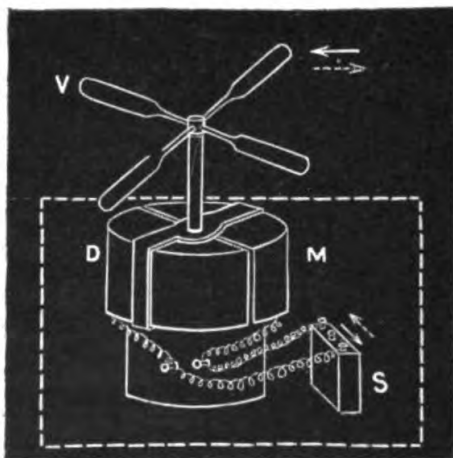

FIG. 278. Diagrammatic Representation of a Windmill with Attached Dynamo, D, and Accumulator, s

Wind acting on vanes, *v*, from right, represented by arrow (\leftarrow), causes responsive rotation in direction opposite to that taken by the hands of a watch. This external energy also causes electrical storage. On the cessation of the wind the accumulator begins to part with its stored-up energy, and, the dynamo now acting as a motor, causes a responsive rotation of the vanes in the other direction, as shown by the arrow (\rightarrow).

been hidden from his view. He finds that the energy supplied from outside is being transformed by a dynamo inside, and stored up in an accumulator. When the external force is not acting, the reverse movement is caused by the internal energy thus stored up. This very movement, being apparently without a cause, he would formerly have designated as automatic. When the stored-up energy is exhausted, the seemingly autonomous movement comes to a standstill, and only by the accession of fresh external stimulus, causing renewed storage, can it be resumed. At a given moment, moreover, the responsive movement of the vanes is determined by the opposing actions of the external and internal factors. As long as the wind is sufficiently strong, movement takes place in one direction, and when there is a pause the internal energy begins to find expression, by causing movement in the opposite direction. If the circumstances were such that the rise of the wind were synchronous with day, and its fall with night,

At a given moment, moreover, the responsive movement of the vanes is determined by the opposing actions of the external and internal factors. As long as the wind is sufficiently strong, movement takes place in one direction, and when there is a pause the internal energy begins to find expression, by causing movement in the opposite direction. If the circumstances were such that the rise of the wind were synchronous with day, and its fall with night,

the windmill, with its alternate movements, would afford a very excellent illustration of the alternate day and night phases in the nyctitropic movement of the plant.

Now, with regard to the living machine, similarly, a full insight into its action can only be obtained if we are able to disentangle the two opposite factors, of internal energy and external stimulus, and follow them into their responsive expressions, at the same time recognising that the principle of the conservation of energy must hold good in the living system as in the non-living. External energy acting on the plant performs work *on* it, a part of this incident energy being taken and held latent ; and, in virtue of the latent energy so conserved, work is performed *by* the plant. Of this internal work, besides the potential chemical energy which is accumulated, the maintenance of suction, growth, and autonomous movements may be cited as examples.

Fundamental unity of physiological response in plant and animal.—Having now seen the intimate connection which exists between the physical and the physiological, and having also seen that the molecular response of the inorganic is not altogether different from that of the plant, it remains only to glance at the physiological continuity of response as between plant and animal ; and here we shall find that there is hardly any phenomenon of irritability, observed in the case of animal tissues, which is not also to be discovered in some simple form in the case of the plant. These resemblances, moreover, are so numerous and so detailed as to lead us inevitably to the conclusion that we have to deal in the two cases with a single identical phenomenon.

In the longitudinal response of a radial vegetable organ we have seen how similar is responsive contraction in animal and plant ; and that this similarity extends even to characteristic details is seen when we compare the records of the Kunchangraph in the case of the plant, with those of the Myograph in that of the animal. The two are alike in the exhibition of a latent period, which is prolonged by cold and reduced by warmth. The staircase increase of the respon-

sive effect, its diminution by fatigue, and the induction of tetanus under rapidly succeeding stimuli, in either case corresponds to a like phenomenon in the other. Fatigue-relaxations, moreover, under strong and long-continued stimulation, are the same in both. And, turning to the electrical mode of response, we find that the excitatory condition of a tissue is indicated by its induced galvanometric negativity, whether the tissue be animal or vegetable; and further, similar physiological modifications, as induced by the action of various external agents, are manifested by similar changes in the two cases in the electrical response.

As by the nerves of the animal, so also by certain conducting channels in the plant-tissue, the state of excitation is, in the two cases alike, transmitted to a distance; and this conduction takes place in both by propagation of protoplasmic changes. In both alike, cold reduces, and warmth accelerates, the velocity of the transmission. In both alike, the stronger the stimulus, the greater is the velocity with which it is transmitted. In both, this velocity is diminished with fatigue. Anæsthetics cause the temporary abolition of conduction in both. The anode, again, blocks the transmission of the excitatory wave in both. And, lastly, the velocity of the transmission of excitation in the plant is comparable to that of its transmission in the nerves of some of the lower animals. Thus, in a certain specimen of the sensitive *Mimosa*, excitation was found to be transmitted with a velocity of 14 mm. per second; and in the ordinary plant *Ficus religiosa* this velocity was determined at 9.4 mm. per second; while in the nerve of *Anodon* a value of 10 mm. per second has been recorded. If, then, the characteristic of nerve be to conduct excitation, it must be admitted that the plant, like the animal, is provided with a nervous system.

In the matter of the excitation induced by the electrical current, there is an equally remarkable similarity of effects in animal and vegetable. Under normal conditions in both cases, the kathode excites at make and the anode at break;

and that reversal of these normal effects which is liable to occur under fatigue, or under excessively strong electromotive force, is the same in the one case as in the other. In addition, moreover, to the contractile effects of kathode-make and anode-break, the plant exhibits a responsive expansion at anode-make and kathode-break, which is also seen in animal tissues.

Turning next to such tissues as are characterised by the property of rhythmicity in a marked manner, we have seen that this effect as exhibited by the plant cannot be distinguished from that in the animal. The rhythmic tissues of the plants *Biophytum* and *Desmodium* are characterised by the possession of relatively long refractory periods, a peculiarity which also marks the rhythmic cardiac muscle of the animal. The response of rhythmic tissues in both plant and animal is found to be on the 'all or none' principle. In both alike the rhythmic tissue is incapable of tetanus; and in both, when at standstill, a single moderate stimulus gives rise to a single response, and stronger stimulus to a multiple series of responses. In *Desmodium*, again, as in the cardiac muscle, increased internal hydrostatic pressure renews pulsation in a tissue at standstill. In rhythmic tissues, again, whether animal or vegetable, under favourable tonic conditions, persistent pulsatory movements take place which are apparently automatic; and these rhythmic pulses are found to exhibit the same types of cyclic variation in the plant as in the animal. The effects of temperature on both are exactly the same—that is to say, its rise increases the frequency and diminishes the amplitude of pulsation. And still more striking, finally, is the identity of the modifications induced by drugs in the rhythmic responses of animal and vegetable.

But this unity of rhythmic responses in plant and animal is not merely a question of their fundamental characteristics. They sometimes appear also to subserve functions somewhat similar. Thus the rhythmic cardiac tissue of the animal maintains the circulation, and we have seen that the rhythmic tissue of the plant maintains the ascent of the sap.

From such considerations it may perhaps appear not very far-fetched to regard a plant as possessed of a diffuse heart.

With special reference to the effect of drugs on plant and animal tissues, we find the identity of phenomena similarly impressive. This is exemplified in both cases by their action not only on ordinary contractile tissues, but on rhythmic tissues also. Thus it is only necessary to mention such facts as that anæsthetics, like the vapours of ether and chloroform, induce a transient abolition of excitability, with abolition of response, in both animal and vegetable; that this excitability, with its concomitant response, is gradually restored in either case on blowing off the applied vapour; and that poisonous reagents, on the other hand, induce a permanent abolition of all response. The action of these and other chemical agents has already been described in some detail.

In the case of rhythmic response, again, a like parallelism was found to exist, as between the effects of drugs on plant and animal tissues respectively; and this parallelism was further shown to extend through a wide range of phenomena. A remarkable instance was seen in the antagonistic effects on responsive rhythmic tissues of the actions of acid and alkali. Acid, when applied to cardiac muscle, induces a diastolic standstill, whereas the effect of alkali is exactly the opposite, a standstill, namely, of systolic contraction; and the standstill induced by either of these is found to be counteracted by the application of the other. Now, I have shown that the effects of acid and alkali on the rhythmic tissues of *Desmodium* are similarly antagonistic. Thus, dilute hydrochloric acid induced arrest of pulsation in the diastolic, or relaxed, position, in the motile organ of *Desmodium*; whereas, with solution of sodium hydrate, the induced arrest was of systolic contraction. Moreover, when arrest in its own particular position had been brought about by either of these reagents, its effect was neutralised by the application of the other (p. 353). The same effects were found again curiously reproduced in the case of the autonomous response of growth. Here, the application of acid induced an arrest

of growth, but only after an abnormal relaxation or expansion. Alkali, on the other hand, induced arrest, but after contraction. And, finally, the arrest induced by one was counteracted by the effect of the application of the other (p. 484). These facts, and others which have already been fully described, afford a conclusive demonstration of the essential unity of the physiological effects of drugs on plant and animal tissues.

The existence of such a unity having been established, it is evident that much may be gathered from investigations carried out on plants, as to the obscure question known to medical practice as the modification of the effect of drugs by individual constitutions; for while a given individual will succumb quickly to the action of a certain poison, another, as is well known, will throw off its influence and survive. Again, a particular dose of a given drug may have the effect of producing excitation in one case, and in another profound depression. The effect on a tissue of any given reagent, then, does not merely represent the action of that reagent as such, but is further determined also by the reacting power of the responding tissue itself. And this reacting power is modified by what is known as the individual constitution of the organism. Thus no result can be definitely predicted of a reagent, unless we have a precise knowledge of the action of the same drug on various definite constitutions. This problem, of the variations induced in the effects of drugs by the different reacting powers of different constitutions, may now be attacked, therefore, through the study of the plant, in which, as I have shown, it is possible to induce known differences of constitution by artificial means.

It was shown, for example, in one case that, while a 5 per cent. solution of the poisonous reagent, copper sulphate, produced an immediate depression, quickly followed by death, another similar plant, whose tonic condition had been raised to the optimum, was found to withstand the action of this poison for a considerable time, the immediate effect being an actual exaltation of its response. The opposite effects of the

same dose on different constitutions were shown, again, in the fact that, while a 1 per cent. solution of copper sulphate caused depression, and subsequent death, of a plant under normal tonic conditions, the same dose in the case of a similar specimen, which had been raised artificially to the optimum condition, brought about exaltation of response, which was found to continue for a fairly long period, after which the effect of the poison was completely overcome (p. 487).

The generalisation which has thus been established will be found to be of great significance. A unity of phenomena, as between animal and plant, so fundamental, so detailed, as has been shown to exist, points unmistakably to a basic property of responsiveness common to the two, and manifested in both alike by the same effects and modification of effects under stimulation. Nor is the power of response something which makes its appearance suddenly in organic substances only, for it has been demonstrated as existing even in the inorganic. Thus inorganic and organic are held together in a linked continuity. All are responsive, all are depressed by fatigue, all are made excitable by stimulants and rendered irresponsive by 'poisons.' Again, with regard to plants, it may be said that there is hardly a responsive physiological peculiarity in the highest animal that may not be found foreshadowed here. Thus the serial development of the physiological functions in these two cases has been more or less parallel.

In the establishment of this generalisation, further, it has been made possible to solve many of the most obscure and difficult problems of Animal Physiology, by studying them under the simple and more manageable conditions of vegetable life. That this is the case has already been seen in many instances, such as that of the polar effects of currents and their reversal under given conditions; in the light shed on the nature of automatism; in the different parts played by external stimulus and internal energy, and their mutual relation; in the bifurcated expression of incident stimulus as external and internal work; and finally, in the

similar action of chemical reagents on plant and animal. It must be remembered, moreover, that one of the greatest advantages to be derived from such a use of the plant as a means of physiological investigation, lies in the fact that this study can be carried on with intact and growing specimens under normal circumstances. The experimental conditions are in this case, therefore, better than those which correspond to them in regard to animal tissues, since the latter specimen will generally be found to be suffering from the effects of injury, and may therefore have been rendered abnormal to an unknown degree. The study of the responsive phenomena in plants must thus form an integral part of physiological investigation into the various problems relating to the irritability of living tissues, and without such study that investigation must in future be regarded as incomplete.

In thus reviewing the movements of plants as a whole, in the light of the investigations which have been described in the course of the present work, we cannot have failed to be struck by the fact that all alike represent, under changing conditions, a single fundamental responsive phenomenon; and this response of the plant offers us, as we have seen, a means of tracing the process by which physiological differentiation from simple to complex has taken place, under the action of stimulus itself. It also enables us to refer a specific differentiation back to definite forces, which have acted asymmetrically upon the organism and induced such a change. We are thus able to see that responsive movements apparently opposite in kind, are nevertheless traceable, not to different specific sensibilities, but to a single universal sensibility, finding different expressions by reason of these induced physiological differentiations.

Theory of Darwin.—It will be remembered that, according to the theory of Darwin, a given individual variation which might be in any way advantageous to the organism was perpetuated by the process of natural selection. Thus, in the struggle for existence, only those could continue to live

that were best fitted to their external conditions. Going back a step, however, to the question of the origin of these variations themselves, we find that by some writers they are held to be due to spontaneous unknown causes, inherent in the organism. Now it would obviously be more satisfactory, since no effect can occur without a cause, if we could assign at least some of these variations to something more definite than this. And Darwin himself was of opinion that variability of every kind was due, directly or indirectly, to changes in the conditions of life. It was difficult, however, to distinguish clearly how much of any given variation was due 'to the accumulative action of natural selection, and how much to the definite action of the conditions of life.'¹

It was this difficulty which, for example, compelled him to ascribe the movements of plants to specific heliotropic or geotropic sensibilities, acquired as the result of natural selection. The particular reaction or reply to stimulus, manifested by the plant in any special case, was thus to be regarded, not as the direct and necessary result of changes in the environment, but as an adaptive act forced on the species by the struggle for life.

Variation as induced by external forces.— With the delicate modes of investigation, however, which are now at the disposal of observers, it has become possible to demonstrate a direct connection between some of the differentiations induced in plant-organs and the conditions of the environment. The factors which are conceivable as bringing about variation may be classed under two heads, first, internal or spontaneous, and second, those which arise from external stimulus; but with regard to the first of these we have seen that, as far as experiment has carried us, there is no such thing as spontaneity, in the sense of an effect which occurs without antecedent cause, for the internal energy to which such seeming actions have hitherto been vaguely ascribed has been shown to be itself traceable to external stimulus. And as regards the effect of external stimulus, on

¹ Darwin, *Origin of Species*, p. 107.

the other hand, we have seen that under its action in nature, heterogeneity is evolved out of homogeneity. Thus it is the unequal action of an external force which, for example, causes a radial organ to become anisotropic, with corresponding physiological complexity, culminating in dorsi-ventrality. One instance of an organ in which, owing to this differentiation, a movement of apparent advantage to the plant has been induced, is found in the pulvinus of *Oxalis*. Here, by the greater excitability of the lower half, the leaflets are made to fold downwards, with the consequence of avoiding too intense illumination, in the responsive movement known as diurnal sleep. But the differentiation which we find here is not unique or suddenly evolved, for we find a similar anisotropy even in the pulvinoids of ordinary leaves such as those of *Artocarpus*. And such physiological differentiation can be traced still further back, to the case of organs which were originally radial. Thus, a long stem, such as that of *Cucurbita*, happening to become recumbent, becomes also dorsi-ventral, by the unequal action of sunlight on the two sides, the too long excited upper side being now the relatively less excitable. There is again no fixed line of demarcation between this more or less permanent and a transient differentiation; for when a radial stem of *Cucurbita* is acted on by a transient unilateral stimulus, a temporary anisotropy is induced as between the excited and the unexcited sides, the latter, which is fresh, being now the more excitable; but this anisotropy immediately disappears on the recovery from excitation of the excited side. We may thus have in the same organ at different times a transient anisotropy, lasting for a minute or so, under moderate unilateral stimulation; a more prolonged anisotropy, lasting for an hour or so, under stronger stimulation; and a permanent differentiation under still stronger and longer continued unilateral stimulation. The difference between the first and the last of these is simply a question of whether the limit of elasticity has been exceeded or not. In a torsioned wire, similarly, on the cessation of moderate

stress, there is complete recovery; and the same wire, when torsioned beyond the limits of elasticity, does not recover, but remains permanently strained. In the same way, we have seen that the effect of stimulus on a living tissue is to induce a molecular derangement, from which there is complete recovery, with a concomitant recovery of all the physiological properties, if the derangement have been not too great; but, with excessive or long-continued stimulus, the limit of physiological elasticity is exceeded, and a permanent physiological differentiation is thus induced.

The same causes, moreover, which initiated the primitive differentiation may now act to induce further a series of complex movements. Thus we first see plagiotropic dorsi-ventrality induced in the creeping stem of *Cucurbita*, by the unilateral action of sunlight; and then the diurnal periodicity of light and darkness acting on this already differentiated organ to cause a periodic swing, which increases with repetition. In this we have, as has been pointed out, the first stage in the evolution of the nyctitropic movement. Now, it is quite possible that this nyctitropic movement may be found, at least in some cases, to subserve the advantage of the plant; yet it would not be true to say that it was evolved for the purpose of such advantage. Indeed, we have to guard ourselves carefully against being led, by this theory of the final advantage of the plant, into an argument in a circle. Assuming any given movement to be advantageous to the plant, we have first to determine the nature of the mechanism by which it is produced, and secondly to find out what was the exciting cause, and what the character of the conditions under which it first arose. If we are not guided in our inquiry by such considerations, we are liable to be misled in our inferences. One such example was seen in the general belief that a certain specific sensibility resides in the root-tip, by which it is endowed with the faculty of moving away from rough surfaces, which might have been injurious to it. So far from its having any such peculiar faculty, however, we found that when a red-hot wire was presented to it

the tip moved towards it, and was thus destroyed. The sensitive reaction of the root-tip is thus seen to be, not an adaptive act evolved for the advantage of the plant, but merely an example of the general law, that under moderate stimulation it is the indirect effect of stimulus that reaches the growing organ and causes movement away from, while under strong stimulation the direct effect determines movement towards, the source of stimulus. Now, it is perfectly true that had any given reaction been such as, under normal conditions, to bring about the self-destruction of large numbers of organisms, we should not have witnessed the survival of organisms characterised by that particular movement. The plant lives because the physiological differentiations induced in it under natural conditions, and the movements induced under periodic changes of those conditions, are in harmony with the fluctuating forces of the environment. Thus the forced rhythm becomes more deeply impressed with repetition, and the greater is the harmony between this rhythm and the environment, the greater will be its stability under given conditions ; the plant persists, that is to say, because it is perpetually in tune, instead of perpetually at war, with its surroundings. We may take it, therefore, in the case of any particular movement, that it constitutes an expression of this stable relation of the plant to its environment, but not that it represents any deliberate adaptation to such an end.

Reverting to the nyctitropic movement in particular, we find it adduced by Darwin as to a certain extent furnishing an example of the influence of heredity on the individual organism, a view which has been questioned. But if we are prepared to give a sufficiently extended and consistent meaning to the word, we must accept this, for heredity is essentially the repetition of a past cycle, the persistence of after-effects ; and there are innumerable degrees of such persistence, between that of a transitory after-effect and the phenomenon of absolute persistence, if such occurs. The diurnal periodicity of *Mimosa*, for example, is maintained for several days under unchanging conditions of illumination or of darkness,

3 C

after which the impressed periodicity is lost. The autumnal periodicity of trees which grow in temperate climates, where the leaves are habitually shed at the approach of winter, persists for a few or for numerous years when the plant is transferred to a warm climate. Certain species of bacteria, again, can be made to exhibit an artificial change of characteristics which will persist during many generations, even on the return of the organism to normal conditions; but even after this degree of hereditary persistence of effect has been exhibited, these induced varieties are liable to undergo reversion to their original type. It is thus seen that the persistence of hereditary characteristics is merely relative. Had it been absolute, the species itself would have been immutable. A given rhythm only persists so long as those circumstances which originally occasioned it persist, and during a certain period afterwards; but this after- or hereditary-effect must, in the non-continuance of the original periodically exciting cause, prove, however long maintained, to be but transitory, like the ultimate arrest of a pendulum when its vibrational energy is exhausted.

The phenomenon of life, then, introduces no mystical power, such as would in any way thwart, or place in abeyance, the action of forces already operative. In the machinery of the living, as in that of the non-living, we merely see their transformation, in obedience to the same principle of conservation of energy as obtains elsewhere; and it may be expected that, in proportion as our power of investigation grows, the origin of each variation of the living organism will be found more and more traceable to the direct or indirect action upon it of external forces, the element of chance being thus progressively eliminated, as the definite sequence of cause and effect comes to be perceived with an increasing clearness; and only, I venture to think, as this is worked out, can we learn to apprehend fully the true significance of the great Theory of Evolution.

CLASSIFIED LIST OF EXPERIMENTS

DIFFERENTIAL MECHANICAL RESPONSE

Mimosa :

	PAGE
1. Response to induction shock	21
2. Isometric response	26
3. Determination of latent period and its variation by cold	268
4. Variation of latent period by fatigue	269
5. Response to artificial turgidity variation	46
6. Effect of excessive turgor on sensibility	49
7. Erectile response to suction	426
8. Response to transmitted direct stimulation	531
9. Response to indirect stimulation longitudinally transmitted	532
10. Response to indirect stimulation transversely transmitted	532
11. Response under favourable tonic condition when chemically stimulated by salt solution	551
12. Response to salt solution in ordinary tonic condition	552

Biophytum :

13. Response to transmitted stimulation with preliminary erectile twitch	24
14. Response to direct stimulation	24
15. Effect of load	25
16. Determination of minimally effective stimulus	27
17. Effect of cold on latent period	141
18. Response to increased internal energy	400
19. Demonstration of factor of internal energy in the process of recovery	401
20. Response on 'all or none' principle	272
21. Determination of refractory period	273
22. Additive effect	274

Philanthus urinaria :

23. Latent period diminished by intensity of stimulus	44, 271
---	---------

Ordinary leaves :

24. Response of <i>Citrus decumana</i>	64
25. Response of <i>Artocarpus</i>	55
26. Response of <i>Artocarpus</i> to indirect stimulation	420
27. Localisation of motile area in <i>Artocarpus</i>	58

3 C 2

Anisotropic organs :

	PAGE
28. Inorganic response of compound strip	13
29. Response of plagiotropic stem of <i>Cucurbita</i>	85
30. Response of plagiotropic stem of <i>Convolvulus</i>	86
31. Response by collapse of bifurcated <i>Allium</i> peduncle	87
32. Response by uncurling of <i>Passiflora</i> tendril	89
33. Response of spirally cut <i>Allium</i> peduncle by uncurling	91
34. Writhing response of spiral tendril of <i>Passiflora</i>	92

LONGITUDINAL MECHANICAL RESPONSE

35. Response of stem of <i>Cuscuta</i>	76
36. Response of root of Bindweed	77
37. Response of style of <i>Datura alba</i>	78
38. Response of coronal filament of <i>Passiflora</i>	78
39. Effect of age on excitatory contraction	79
40. Effect of season on responsive contraction	80

ELECTRIC RESPONSE

41. Response to direct stimulation	32
42. Response to transmitted direct stimulation	34
43. Indirect hydrostatic and true excitatory response	37
44. Electric test of differential excitability	38
45. Response to moderate stimulation of tip of growing organ	517
46. Response to strong stimulation of tip	517, 518
47. Response to direct stimulation of growing region	518
48. Response to moderate transverse stimulation	519
49. Response to strong transverse stimulation	519, 522

ELECTROTACTILE RESPONSE

50. Electrotactile response in <i>Mimosa</i> stem	260
---	-----

DEATH-RESPONSE

51. Determination of death-point by electrical method	149
52. Determination of death-point by spasmodic lateral response	150
53. Determination of death-point by spasmodic movement of uncurling	155
54. Determination of death-point by sudden volumetric contraction	156
55. Determination of death-point from critical point of thermo-mechanical inversion	168
56. Constancy of critical point of inversion	169
57. Modification of thermo-mechanical curve showing effect of age	170
58. Thermo-mechanical curve of <i>Mimosa</i>	172
59. Duplication of rigor-point in <i>Mimosa</i> by chemical agents	179
60. Translocation of death-point by unfavourable weather	172, 176
61. Translocation of death-point by poisonous solution	180
62. Translocation of death-point by fatigue	185

CLASSIFIED LIST OF EXPERIMENTS

757

	PAGE
63. Death-response of flowers	182
64. Thermograph of regional death	183, 184

MULTIPLE AND AUTONOMOUS RESPONSE

65. Multiple electromotive response	279
66. Multiple electro tactile response	280
67. Multiple mechanical response in <i>Biophytum</i>	283
68. Cyclic variation of multiple response in <i>Biophytum</i>	285
69. Cyclic variation of multiple visual response	287
70. Multiple response in <i>Desmodium</i> originally at standstill	293
71. Multiple response to constant chemical stimulus in <i>Biophytum</i>	300
72. Multiple response to constant current in <i>Averrhoa</i>	300
73. Multiple response to constant light in retina	301
74. Multiple response to constant light in <i>Biophytum</i>	302
75. Multiple response to constant light in <i>Desmodium</i>	303
76. Initiation of autonomous response in <i>Biophytum</i> above thermo-tonic minimum	305
77. Resumption of autonomous response in <i>Desmodium</i> by accession of energy	306
78. Resumption of autonomous response in <i>Desmodium</i> under increased internal hydrostatic pressure	307
79. Localisation of seat of autonomous excitation in <i>Desmodium</i>	297
80. 'Systolic' and 'diastolic' positions in <i>Desmodium</i> pulsation	320
81. Incapability of tetanus in <i>Desmodium</i>	346
82. Measurement of period and amplitude of <i>Desmodium</i> pulsation from photographic record	317
83. Measurement of period and amplitude of <i>Desmodium</i> pulsation from spark record	327
84. Periodic variation in <i>Desmodium</i> pulsation	341, 470
See also <i>Periodic variation of growth</i> and <i>Suctional response</i>	472, 473, 474

SUCTIONAL RESPONSE

85. Record of suction, Unbalanced Method	373
86. Shoshungraphic record under Hydrostatic Balance	376
87. Shoshungraphic record under Hydraulic Balance	368
88. Renewal of suctional response under stimulus	382
89. Periodic variation of transpiration in <i>Cucurbita</i>	472
See also <i>Mechanical, Growth, and Torsional responses to suctional activity</i>	400, 426, 669

GROWTH-RESPONSE

90. Balanced Method of Crescographic record	412
91. Multiple growth-pulsation	417
92. Cyclic groupings of multiple growth-pulsation	417, 425
93. Resumption of growth by stimulus	425
94. Resumption of growth in drought-rigored <i>Cucurbita</i> after supply of water	426

	PAGE
95. Growth in response to hydraulic transmission of energy	430
96. Effect of decreased suctional activity on growth	429
97. Effect of increased hydrostatic pressure on growth of <i>Balsam</i>	428
98. Effect of increased hydrostatic pressure on growth of <i>Crinum Lily</i>	428
99. Effect of tension on growth	433
100. Bifurcated expression of stimulus in contractile response and resumption of growth	435
101. Similarity of response in stationary and growing organs	436
102. Retardation of growth by external stimulus	436
103. Detection of latent stimulus by negative after-effect	459
104. Constancy of sum of direct effect and negative after-effect	460
105. Vanishing of latent component above the optimum	461
106. Variation of receptivity with temperature	461
107. Direct and indirect effect of stimulus on plant in different tonic conditions	462, 463
108. Diurnal variation of rate of growth in <i>Oryza sativa</i>	473
109. Diurnal variation of rate of growth in seedling of <i>Tamarindus indica</i>	474
110. Effect of high frequency Tesla current on growth	619
111. Effect of Hertzian waves on growth	618

RESPONSIVE GROWTH-CURVATURES

112. Response of pistil of <i>Musa</i> to unilateral thermal stimulation	68
113. Response of <i>Crocus</i> to moderate unilateral stimulation of tip	526
114. Response of <i>Crocus</i> to stronger stimulation	526
115. Response of <i>Crocus</i> to direct stimulation of growing region	527
116. Response of root of Bindweed to unilateral stimulus of tip	526
117. Response of root of Bindweed to stronger stimulation of tip	527
118. Response of root of Bindweed to unilateral stimulation of growing region	527

TORSIONAL RESPONSE

119. Torsional response of pulvinus of <i>Mimosa</i> under lateral stimulus of light	659
120. Torsional response of pulvinus of <i>Mimosa</i> under lateral chemical stimulus	659
121. Torsional response of inorganic compound strip	660
122. Modification of torsional response in <i>Mimosa</i> by reversal of differential excitability of pulvinus	661
123. Modification of torsional response in <i>Mimosa</i> by increase of differential excitability of pulvinus	662
124. Torsional response in <i>Erythrina indica</i> under lateral geotropic stimulus	664
125. Modification of geotropic torsion by reversal of differential excitability	665
126. Modification of geotropic torsion by increase of differential excitability	665
127. Autonomous torsion of stems	668

	PAGE
128. Enhancement of rate of autonomous torsion by increased suctional activity	669
129. Modification of rate of autonomous torsion by electrical current	670

UNIFORM RESPONSE, FATIGUE, AND STAIRCASE EFFECT

130. Uniform electrical response in Radish	104
See also <i>Uniform mechanical responses in Biophytum and Datura</i>	24
131. Staircase effect in mechanical response of <i>Eucharis</i>	104
132. Staircase effect, followed by fatigue, in the response of <i>Eucharis</i>	121
133. Staircase effect, followed by fatigue, in the response of <i>Bryophyllum</i>	122
134. Staircase effect in inorganic response of <i>Galena</i>	121
135. Fatigue in mechanical response of <i>Datura</i>	105
136. Fatigue-reversal under continuous stimulation in <i>Passiflora</i>	108
137. Fatigue-reversal under continuous stimulation in <i>Mimosa</i>	109, 113, 552
138. Periodic fatigue in <i>Urticis</i>	108
139. Fatigue in electrical response of Radish	105
140. Fatigue-reversal under continuous stimulation in electrical response of Celery	107
141. Alternate fatigue in electrical and mechanical response	106
142. Fatigue in inorganic response : arsenic	119
143. Fatigue in inorganic response : india-rubber	120
144. Alternating fatigue in arsenic	575
145. Apparent fatigue in response of plant, due to bifurcation of energy	127

ADDITIVE EFFECT AND RELATION BETWEEN STIMULUS AND RESPONSE

146. Additive effect in mechanical response	94
147. Additive effect in electrical response	95
148. Genesis of tetanus in mechanical response	99
149. Relation between intensity of stimulus and amplitude of mechanical response	96
150. Relation between intensity of stimulus and amplitude of electrical response	97
151. Influence of tonic condition on relation between stimulus and responsive growth-retardation	467

POLAR EFFECTS OF CURRENTS

Pulvinar response :

152. Action of feeble E.M.F. on <i>Mimosa</i> , Mono-polar Method	192
153. Action of feeble E.M.F. on <i>Mimosa</i> , Bi-polar Method	194
154. Action of feeble E.M.F. on <i>Biophytum</i> , Mono-polar Method	193
155. Action of feeble E.M.F. on <i>Biophytum</i> , Bi-polar Method	194
156. Effect of moderate E.M.F. on <i>Biophytum</i>	195
157. Effect of moderate E.M.F. on highly excitable tissues	197
158. Effect of moderate E.M.F. on <i>Desmodium</i>	292

	PAGE
Reversing effect of high E.M.F. :	
159. A stage, <i>Biophytum</i>	204
160. <i>Mimosa</i>	204
161. B stage, <i>Averrhoa</i>	205
162. and fatigue, <i>Mimosa</i>	208
163. Localised effect of Anode and Kathode on pulvinus of <i>Erythrina indica</i>	555
Death-response :	
164. Polar effects of moderate E.M.F. on death-response	185
165. Polar effects of high E.M.F. on death-response	207
Glow-response :	
166. Polar action of moderate E.M.F. on glow-response of firefly	212
167. Reversal of effects by high E.M.F. or by tissue-modification	213
Growth-response :	
168. Anodic and cathodic effects on growth of root of Bindweed	557
169. Galvanotropic response of <i>Crinum Lily</i>	558
170. Indirect effect of polar excitation on <i>Champaca</i>	559
171. Effect of electrification of soil on growth of <i>Oryza saliva</i>	560
See also <i>Galvanotaxis</i>	698

EXCITABILITY AND CONDUCTIVITY

172. Diminution or abolition of motile excitability by anæsthetics	220
173. Diminution or abolition of motile excitability by cold	220
174. Diminution or abolition of motile excitability by fatigue	221
175. Diminution or abolition of motile excitability by An-electrotonus	236
176. Increase of excitability by Kat-electrotonus	235
177. 'Developing' action of Kathode	236
178. Diminution or abolition of conductivity by anæsthetics	223
179. Diminution or abolition of conductivity by cold	221
180. Diminution or abolition of conductivity by fatigue	223
181. Diminution or abolition of conductivity by anodic block	233
182. An-electrotonic and Kat-electrotonic action on conductivity	233
183. Depression of receptive excitability by anæsthetics	225
184. Receptivity <i>versus</i> motile excitability	226
185. Excitability <i>versus</i> conductivity	227, 229

VELOCITY OF TRANSMISSION OF EXCITATORY WAVE

186. Detection of excitatory pulse during transit by Chemical Method.	255
187. Detection of excitatory pulse during transit by Electrotactile Method	257
188. Detection of excitatory pulse during transit by Electromotive Method	261
189. Determination of velocity of transmission in <i>Biophytum</i> by mechanical response	241

CLASSIFIED LIST OF EXPERIMENTS

761

	PAGE
190. Determination of centrifugal and centripetal velocities	243
191. Effect of fatigue on velocity	245
192. Effect of intensity of stimulus on velocity	246
193. Effect of lowering of temperature on velocity	248
194. Effect of rise of temperature on velocity	249
195. Relative velocities in various plants, 'sensitive' and ordinary	252

EFFECT OF TEMPERATURE ON RESPONSE

Mechanical response :

196. Effect of cold on longitudinal contractile response	143
197. Effect of rise of temperature on longitudinal contractile response	144
198. Effect of cyclic rise and fall of temperature	146

Electric response :

199. Diminution of response in <i>Eucharis</i> by lowering of temperature	140
200. After-effect of cold on Ivy, Holly, <i>Eucharis</i>	141
201. Effect of rise of temperature	143
202. Effect of cyclic variation of temperature	145

Autonomous pulsation of *Desmodium* :

203. Effect of slight cooling on amplitude and period	332
204. Effect of cooling to thermo-tonic minimum on amplitude and period	335
205. Effect of raising from thermo-tonic minimum upwards	336
206. Effect of continuous rise of temperature on amplitude and period	334
207. Determination of temperature minimum	331
208. Determination of temperature maximum	331
209. Persistence of rhythmic activity at maximum	431

Suctional response :

210. Determination of effect of cold by Unbalanced Method	373
211. Determination of effect of cold by Hydrostatic Balance	376
212. Determination of effect of cold by Hydraulic Balance	379
213. Effect of warm water, Unbalanced Method	375
214. Effect of warm water, Hydrostatic Balance	378
215. Effect of warm water, Hydraulic Balance	380
216. Persistence of suction when root killed by hot water	381

Growth :

217. Determination of various rates at different temperatures by Discontinuous observations	442
218. Determination of various rates at different temperatures from Thermo-crescent curve	447
219. Determination of various rates at different temperatures by Method of Balance	450
220. Determination of various rates at different temperatures by Method of Excitatory Response	452
221. Determination of optimum point by Method of Balance	451

	PAGE
222. Translocation of optimum point	454
223. Persistence of rhythmic activity at maximum	432

Autonomous torsion :

224. Effect of temperature on rate of autonomous torsion	668
--	-----

EFFECT OF CHEMICAL AGENTS**Mechanical response :**

225. Effect of carbonic acid	131
226. Effect of hydrogen	132
227. Effect of carbon disulphide	132
228. Effect of alcohol	133
229. Effect of ether on longitudinal response	134
230. Effect of ether on motile response of <i>Mimosa</i>	135
231. Effect of acid	136
232. Effect of chlorine gas	137

Autonomous pulsation of Desmodium :

233. Effect of ether	323
234. Effect of alcohol	324
235. Effect of carbonic acid gas	325
236. Effect of copper sulphate solution	326
237. Effect of barium salt solution	351
238. Arrest at 'diastole' by acid	352
239. Arrest at 'systole' by alkali	353
240. Antagonistic actions of acid and alkali	353

Suctional response :

241. Action of KNO_3 solution	384
242. Osmotic <i>versus</i> excitatory action of NaCl solution	384

Growth :

243. Effect of carbonic acid	479
244. Action of ether, external application	480
245. Action of ether, internal application	481
246. Excitatory effect of dilute solution of sodium carbonate	482
247. Effect of solution of sugar	482
248. Effect of alcohol	483
249. Effect of acid inducing relaxation and arrest	483
250. Effect of alkali inducing contraction and arrest	484
251. Antagonistic actions of alkali and acid	484
252. Action of strong sodium chloride solution under different thermo- tonic conditions	485
253. Differing effects of poisons on different 'constitutions'	487
254. Opposite effects of same poisonous dose on different 'constitutions'	487
255. Opposite effects of large and small doses	488

Growth-curvature :

	PAGE
256. Chemo-tropic effect of alkali	548
257. Antagonistic chemo-tropic effect of acid	548
258. Effect of copper sulphate solution	548
259. Effect of sugar solution	549
See also <i>Chemo-tactic response</i>	699

GEOTROPISM

260. Apo-geotropic response of scape of <i>Utricularia</i>	499
261. Response of <i>Crinum</i> Lily under unilateral pressure of particles	498
262. Apo-geotropic response at inclinations of 45° and 135°	501
263. Demonstration of apo-geotropic curvature as induced by responsive contraction	504
264. Effect of alternate applications of cold on upper and lower surfaces on apo-geotropic response	505
265. Darwinian curvature and its reversal under different intensities of stimulation	536
266. Determination of effect of amputation of root-tip on excitability	541
267. Effect of gravitational stimulus on autonomous torsion	671
See also <i>Response to stimulation of tips of root and shoot</i>	526
Also <i>Differential geotropic sensibility of dorsi-ventral organs</i>	662, 666

EFFECT OF VISIBLE AND INVISIBLE RADIATIONS

268. Response of <i>Mimosa</i> to electric radiation	619
269. Discrimination of effects of thermal radiation and of temperature	615
270. Response of <i>Musa</i> to unilateral thermal radiation	616
271. Response of <i>Tamarindus</i> to continuous unilateral thermal radiation	617
272. Effect of diffuse stimulation of light on growth of sub-tonic tissue	574
273. Effect of diffuse stimulation of light on stationary radial organ	571
274. Retarding effect of light on longitudinal growth	572
275. Oscillatory growth-response under continuous action of light	574
276. Effect of light on autonomous torsion	669

HELIO-TROPISM**In radial growing organs :**

277. Positive responses of <i>Sinapis</i> to moderate light	593, 609
278. Positive responses of cooled tendril of <i>Passiflora</i>	611
279. Positive responses of tendril of <i>Vitis</i> to feeble light	611
280. Neutral response of <i>Sinapis</i> under strong stimulation	609
281. Neutral response of tendril of <i>Passiflora</i> to strong stimulation	611
282. Negative response of root of <i>Sinapis</i>	600
283. Negative response of shoot of <i>Crocus</i> on stimulation of tip	601
284. Negative response of tendril of <i>Vitis</i> under strong stimulation	611

In plagiotropic growing organs :

285. Negative response of stem of <i>Cucurbita</i> to strong vertical light	626
286. Negative response of stem of <i>Ipomoea</i> to strong vertical light	625

	PAGE
287. Negative response of stem of <i>Mimosa</i> to strong vertical light	625
288. Positive response of terminal leaflet of <i>Desmodium</i> , stimulated alternately from above and below	586, 587
289. Orientating action of light	587
290. Positive response of <i>Erythrina indica</i> (diurnal sleep movement)	629
291. Positive response of <i>Robinia</i> (diurnal sleep movement)	629
292. Positive response of <i>Clitoria ternatea</i> (diurnal sleep movement)	629
293. Neutral response of <i>Desmodium</i> leaflet under long-continued stimulation	604
294. Positive response of <i>Mimosa</i> , when stimulated alternately from above and below, by light of feeble intensity	631
295. Transition of response in <i>Mimosa</i> , from positive, through neutral, to negative, under continuous light from above	632
296. Negative response of leaflet of <i>Biophytum</i> (diurnal sleep movement)	634
297. Negative response of leaflet of <i>Oxalis</i> (diurnal movement)	633
298. Multiple heliotropic response	303, 584, 604, 634
299. Multiple merging into continuous heliotropic response	586
300. Localisation of heliotropic sensibility in pulvinus	588, 650
301. Lamina not perceptive organ to stimulus of light	651
302. Absence of specific dia-heliotropic tendency in leaves	649
In ordinary leaves :	
303. Positive response of leaf of <i>Mangifera indica</i>	653
304. Negative response of <i>Artocarpus</i>	653
305. Torsional response to lateral stimulation of terminal leaflet of <i>Desmodium</i>	657
See also <i>Torsional response of dorsi-ventral organs</i>	661
306. Limits of flexibility in various leaves	647
Nyctitropic movement :	
307. Diurnal movement of plagiotropic stem	679
308. Diurnal movement of leaf of <i>Biophytum</i>	680
309. Nyctitropic movement of <i>Mimosa</i> leaf, due to cumulative heliotropic action	678
310. Nyctitropic movement of primary petiole of <i>Mimosa</i>	681
311. Impressed heliotropic periodicity in Sunflower	685
Heliotropic action on autonomous response :	
312. Initiation of autonomous response by light in <i>Desmodium</i>	690
313. Changes of amplitude in autonomous pulsation of <i>Desmodium</i>	691
314. Periodic reversals of relative rapidities of up and down beats in <i>Desmodium</i>	692
315. Modification of autonomous torsion	669
See also <i>Phototaxis</i>	696

INDEX

- ACELLULAR organ, responsive curvature of, 506
- Acid, chemo-tropic action of, 548
,, effect on mechanical response, 136
- Acid and alkali, antagonistic action of, on cardiac pulsation, 351
,, ,, ,, ,, on chemo-tropic response, 548
,, ,, ,, ,, on *Desmodium* pulsation, 352
,, ,, ,, ,, on growth, 484
- Additive effect, 95
- After-effect, detection of absorbed stimulus by negative, 459
,, factors modifying, 468
,, persistence of, 310
,, positive and negative, 457
,, ,, ,, constancy of sum of, 460
- Age, effect of, on contractile response, 79
,, ,, on thermo-mechanical inversion, 171
- Alcohol, effect of, on *Desmodium* pulsation, 325
,, ,, on growth, 482
,, ,, on mechanical response, 133
- All or none' principle in response of *Biophytum*, 272
,, ,, ,, cardiac tissue, 353
- Allium*, death-response of, 157
,, mechanical response of, 87
- Anæsthetics, action of, on autonomous response, 324
,, ,, on conductivity, 220, 229
,, ,, on excitability, 220
,, ,, on mechanical response, 134, 135
,, ,, on receptivity, 224
- An-electrotonus, 232
- Anisotropy, induction of, by cold, 82
,, ,, by fatigue, 83
,, ,, by light, 84
,, necessary condition for lateral response, 44
- Annual rings, 474
- Anode, effect of, on growth, 556
- Anodic block, 233
- Arisema*, curious response of, 533
- Arsenic, fatigue-reversal in, 119, 575, 653

- Artocarpus*, effect of over-turgidity, 58
 „ localisation of motile areas in, 58
 „ response of, 55, 420, 653
 Ascent of sap, mechanics of, 390
 „ rapidity of, 392
 „ theories of, 359
 „ uni-directioned flow of, 390
 Autonomous excitation, seat of, in *Desmodium*, 297
 „ response, continuity with multiple, 290, 291
 „ „ induction of, by hydrostatic pressure in cardiac tissue, 307
 „ „ „ „ „ in *Desmodium*, 307
 „ „ „ by accession of energy in *Biophytum*, 305
 „ „ „ „ „ in *Desmodium*, 306
 „ „ periodic groupings of, 291, 350
Avena sativa, heliotropic response of, 604

Balsam, effect of hydrostatic pressure on growth of, 428
 „ growth-pulsation of, 432
 Barium chloride, effect on *Desmodium* pulsation, 351
 Bindweed, effect of section of root-tip on excitability of, 541
 „ polar effect of current in the growth of root of, 556
 „ response of root of, to thermal stimulus, 76, 526, 527
Biophytum, additive effect in, 274
 „ autonomous response of, 305
 „ diurnal sleep movement of, 634
 „ effect of anæsthetics, 223, 225
 „ „ an- and kat-electrotonus, 232-236
 „ „ cold on excitability of, 222, 224
 „ „ „ latent period of, 141
 „ „ load on response of, 25
 „ electric response of, 34, 37
 „ erectile response of, 24, 37, 400
 „ minimally effective stimulus in, 27
 „ multiple response of, 282 *et seq.*
 „ normal mechanical response of, 24, 37
 „ nyctitropic movement of, 680
 „ polar effect of current on, 195, 197
 „ refractory period of, 273
 „ response on 'all or none' principle, 272
 Bi-polar method, 191
Botrydium granulatum, phototaxis of, 497
 Brown, H., on diffusion through multi-perforate septum, 399
Bryophyllum calycinum, response of, 62

 CARBON disulphide, effect of, on mechanical response, 132
 Carbonic acid, effect of, on *Desmodium* pulsation, 325
 „ „ „ on growth, 480
 „ „ „ on mechanical response, 131
 Chemical method, determination of velocity by, 255

- Chemical reagents, effect on autonomous response, 323-326
 „ „ „ growth, 479-488
 „ „ „ mechanical response, 131-137
 „ „ „ suctional response, 383, 384, 385
 „ „ „ modification of effect of, 322
- Chemo-taxis, 698
- Chemo-tropic response : effect of acid, 548
 „ „ „ alkali, 548
 „ „ „ copper sulphate solution, 548
 „ „ „ sugar solution, 549
- Chlorine, effect of, on mechanical response, 137
- Ciesielski on effect of amputation of root-tip, 539
- Citrus decumana*, response of leaf of, 64
- Clitoria ternatea*, diurnal sleep movement of, 629
- Cold, abolition of autonomous response by, 141, 331
 „ „ „ mechanical response by, 141
 „ „ „ suctional response by, 374
 „ „ „ diminution of conductivity by, 221, 249
 „ „ „ prolongation of latent period by, 141, 264
- Cold-rigor, 171
- Colocasia*, excretion of water in, 397
- Conduction, channels of, 60, 250
 „ of excitation and of sap, 391
 „ pseudo-, 251
- Conductivity, difference between longitudinal and transverse, 250
 „ preferential direction of, 242
 „ seasonal variation of, 602
 „ variation of, by anæsthetics, 223
 „ „ by cold, 221, 249
 „ „ by electrotonus, 233
 „ „ by fatigue, 222
 „ „ by rise of temperature, 222, 249
- Conductivity-variation, response by, 39
- 'Constitution,' elements determining, 478
 „ modifying effect of, on action of drugs, 487
- Convolvulus*, death-response of flower of, 182, 183
 „ response of plagiotropic stem to light, 625
 „ „ „ „ to thermal shocks, 86
- Coprinus*, action of light on, 569
- Counterpoise, importance of, 19
- Crescograph, 412-416
- Crinum* Lily, apo-geotropic response of, 498, 500, 504
 „ „ direct and indirect after-effect of stimulus in, 460
 „ „ effect of increased hydrostatic pressure on growth of, 428
 „ „ „ tension on growth of, 433
 „ „ „ unilateral pressure of particles on, 497
 „ „ excitatory response at different temperatures of, 453
 „ „ optimum point of growth in, 448, 451
 „ „ thermo-crescent curve of growth in, 447

- Crocus*, growth-curvature by stimulation of tip and growing region of shoot, 526, 527
- Cucurbita*, diurnal variation of rate of transpiration in, 472
- ,, initiation of growth-pulsation in, 426
- ,, response of plagiotropic stem of, to thermal shocks, 86
- ,, ,, ,, ,, to light, 626
- Cuscuta*, response of stem of, 77
- Cynerea*, response of filaments of, 69
- Czapek on localisation of gravi-perception at root-tip, 542
- ,, on radial pressure theory, 494
- DARKNESS, modification of sensitiveness in, 22, 50
- Darwin, Francis, on effect of alternating stimulation, 685
- ,, ,, on growth-curvature under light and gravitation, 494
- Darwin on localised geotropic sensibility at root-tip, 539
- ,, on sensitiveness of radicle, 513
- Darwinian curvature, 536
- ,, theory, 749
- Datura alba*, style of: death-discoloration of, 183
- ,, ,, ,, death-response of, 160
- ,, ,, ,, effect of light on growth, 571
- ,, ,, ,, lowering of death-point by fatigue, 185
- ,, ,, ,, response of growing and stationary, 434, 435, 436
- ,, ,, ,, response to thermal stimulus, 78
- ,, ,, ,, tetanus in, 99
- Death-discoloration, 183
- Death-point, constancy of, 173
- ,, determination of, by electrical response, 149
- ,, ,, by movement of uncurling, 165
- ,, ,, by spasmodic lateral response, 150
- ,, ,, by thermo-mechanical inversion, 161
- ,, ,, by volumetric contraction, 156
- ,, electrotonic effect on, 185, 186, 199, 207
- ,, translocation of, by age, 170
- ,, ,, by fatigue, 185
- ,, ,, by poison, 180
- ,, ,, by unfavourable weather, 172
- Death-response, effect of chemical agents on, 179, 180
- ,, in flowers, 181
- ,, physiological nature of, 152
- Death-spasm in plants, 150, 155, 156
- De Candolle, theory of heliotropism, 580
- Desmodium gyrans*, multiple response of, 293
- ,, ,, polar excitation of, 292
- ,, ,, seat of autonomous excitation in, 297
- ,, ,, significance of up and down movement in, 330
- Desmodium* pulsation, diurnal record of, 470
- ,, ,, incapability of tetanus, 346
- ,, ,, effect of anaesthetics on, 323

- Desmodium* pulsation, effect of acid on, 352
- „ „ „ alcohol on, 324
 - „ „ „ alkali on, 352
 - „ „ „ barium salt on, 351
 - „ „ „ carbonic acid on, 325
 - „ „ „ copper sulphate solution on, 326
 - „ „ „ light on, 691, 692
 - „ „ „ temperature on, 332-338
 - „ „ „ period and amplitude of, 317
 - „ „ „ periodic variation of, 341
 - „ „ „ similarity between *Biophytum* pulsation and, 345
 - „ „ „ „ „ cardiac pulsation and, 345-354
 - „ „ „ spark-record of, 327
 - „ „ „ temperature, maximum of, 331
 - „ „ „ thermo-tonic minimum of, 331
- Detmer on photonasty, 643
- Development, thermographic, 184
- De Vries on epi- and hypo-nasty, 643
- „ on heliotropic action on leaves, 622
 - „ on plasmolytic method, 549
- Dia-geotropism, so-called, 640, 654
- Dia-heliotropism, so-called, 640-654
- Differential response in plant, 14
- „ „ magnification of, 51
 - „ „ of compound strip, 13
- Directive *versus* non-directive action of light, 634
- Diurnal sleep, 629, 633, 634
- Dorsi-ventral organ, differential geotropic action inducing torsion in, 662
- „ „ „ heliotropic action inducing torsion in, 658
 - „ „ „ no specific sensibility in, 577
- Dutrochet on conducting elements in *Mimosa*, 251
- ELECTRIC** radiation, effect of, on *Mimosa*, 619
- „ response, difference of excitability detected by, 38
 - „ „ laws of, 42
 - „ „ multiple, 279
 - „ „ of inorganic substance, 40
 - „ „ simultaneous mechanical and, 34
 - „ „ to direct stimulation, 32, 518
 - „ „ to indirect stimulation, 37, 517
 - „ „ true excitatory negative and hydrostatic positive, 35, 37
 - „ waves, effect of, on growth, 618
- ‘Electrification’ of soil, effect of, on growth, 560
- Electromotive Method, detection of excitatory wave by, 261
- Electrotactile Method of detection of excitation, 256, 280
- Electrothermic stimulator, 17
- Electrotonus, variation of excitability by, 234, 235, 236
- Elfvig on geotropic action on grass-haulm, 496
- Erythrina indica*, differential geotropic response of, 664, 665

- Erythrina indica*, heliotropic response of, 629
 „ „ polar effect of current on, 555
Eucharis Lily, cold-rigor in, 141, 172
 Excitability, seasonal variation of, 80, 474
 „ variation of, by anæsthetics, 220
 „ „ by cold, 220
 „ „ by electrotonus, 234
 „ „ by fatigue, 221
 „ *versus* conductivity, 227
 „ „ receptivity, 226
 Excitation, longitudinal conduction of, 516, 517, 526, 532, 604
 „ mechanical *versus* protoplasmic theory of, 189, 229
 „ transverse conduction of, 519, 528, 529, 532
 Excitatory contraction, physiological modification of, 79
 „ discharge, preferential direction of, 243
 „ *versus* hydrostatic effect, 35, 47
 „ wave, centrifugal velocity of, 243
 „ „ centripetal velocity of, 243
 „ „ determination of velocity of, by Chemical Method, 255
 „ „ „ „ by Electromotive Method, 260
 „ „ „ „ by Electrotactile Method, 25
 „ „ „ „ by Mechanical Method, 240
 „ „ modification of velocity of, by cold, 248
 „ „ „ „ by fatigue, 245
 „ „ „ „ by intensity of stimulus, 246
 „ „ „ „ by rise of temperature, 249
 „ „ velocity of, in plant and animal, 252
- FATIGUE, alternating, 106
 „ effect of, on conductivity and excitability, 111
 „ „ on electrical response, 105
 „ „ on mechanical response, 105
 „ „ on velocity of transmission, 244
 „ periodic, 65, 108
 „ reversal of normal polar effect by, 207
 Fatigue-reversal under continuous stimulation, in arsenic, 119
 „ „ „ „ in india-rubber, 120
 „ „ „ „ in plant, 63, 107, 108, 109
- Fick on velocity of nervous impulse, 246
 Firefly, glow-response of, 211
 Flexibility, characteristic limits of, 646
 Flowers, death-response of, 181
 Food-substance, translocation of, 398
 Forced vibration, 684
 Frank on heliotropic response of *Marchantia*, 622
 „ on transverse heliotropism and geotropism, 641
 Frost, effect on leaves, 400
- GALENA, staircase response in, 121
 Galvanotaxis, 698

- Galvanotropic response, 558
- Geotropic response, at inclinations of 45° and 135°, 500
- „ „ effect of unilateral application of cold on, 504, 505
 - „ „ mechanics of, 495
 - „ „ method of recording, 499
 - „ „ of shoot and root, 544
 - „ „ torsional, 664
 - „ „ true character of, 502
 - „ sensibility, localisation at root-tip, 539
- Geotropism, differential, 663
- „ radial pressure and statolith theories of, 494
- Glow-response, 211
- Grass-haulms, geotropic response of, 496, 508
- „ growth of, on klinostat, 509
- Greely, A. W., galvanotaxis of *paramoecia*, 698
- Growing organ and pulvinus, identical nature of responses in, 534
- Growth, anodic and cathodic effect on, 556
- „ antagonistic action of acid and alkali on, 484
 - „ apparent arrest of, at high temperature, 432
 - „ balanced record of, 413
 - „ daily periodicity in, 473, 474
 - „ direct and indirect stimulus on, 438
 - „ effect of acid on, 483
 - „ „ alcohol on, 482
 - „ „ alkali on, 483
 - „ „ carbonic acid on, 479
 - „ „ electric waves on, 618
 - „ „ 'electrification' of soil on, 560
 - „ „ ether on, 480
 - „ „ NaCl solution on, 485
 - „ „ Na₂CO₃ solution on, 482
 - „ „ poisonous solution on, 486
 - „ „ sugar solution on, 482
 - „ external stimulus on, 434, 435, 436
 - „ laws of, 439
 - „ opposite effects on, of chemical agents on different 'constitutions,' 487
 - „ „ „ of large and small doses, 488
 - „ optimum temperature of, 448, 451
 - „ „ translocation of, 454
 - „ periodic variation of rate of, 470, 473, 474
 - „ polar action of current on, 557, 558, 559
 - „ relation of, to hydrostatic pressure, 428
 - „ „ to tension, 432
- Growth-curvature, induction of, by electrical current, 553
- „ „ by unilateral stimulus, 525, 527, 528, 529
- Growth-pulsation, multiple, 417, 432
- „ periodic groupings of, 417, 425
- Growth, renewal of, by external stimulus, 425
- „ „ by positive turgidity-variation, 426

- Growth-response and excitatory response, 418
 ,, similarities between pulvinar and, 437
- HABERLANDT on transmission of excitation in *Mimosa*, 251
 ,, on statolith theory, 494
- Heart-beat, theories of, 347
- Hedera helix*, seasonal variation of heliotropic response in, 623
- Heliotropic excitation, transmission of, 604
 ,, negative response of dorsi-ventral organs : leaf of *Artocarpus*, 653
 ,, ,, ,, ,, ,, ,, *Mimosa*, 631, 632
 ,, ,, ,, ,, ,, ,, leaflet of *Biophytum*, 634
 ,, ,, ,, ,, ,, ,, ,, *Oxalis*, 633
 ,, ,, ,, ,, ,, ,, plagiotropic stem of *Cucurbita*, 626
 ,, ,, ,, ,, ,, ,, plagiotropic stem of *Ipomoea*, 625
 ,, ,, ,, ,, ,, ,, plagiotropic stem of *Mimosa*, 625
 ,, ,, ,, radial organs : hypocotyl of *Sinapis*, 609
 ,, ,, ,, ,, ,, *Lepidium*, 608
 ,, ,, ,, ,, ,, root of *Sinapis*, 601
 ,, ,, ,, ,, ,, shoot of *Crocus*, 601
 ,, ,, ,, ,, ,, tendril of *Vitis*, 611
 ,, neutral response : leaflet of *Desmodium*, 604
 ,, ,, ,, *Lepidium*, 608
 ,, ,, ,, *Sinapis*, 609
 ,, ,, ,, tendril of *Passiflora*, 611
 ,, perception, absence of, in lamina, 588, 650, 651
 ,, positive response of dorsi-ventral organs : leaf of *Mangifera indica*, 653
 ,, ,, ,, ,, ,, leaflet of *Clitoria ternatea*, 639
 ,, ,, ,, ,, ,, leaflet of *Desmodium*, 586, 587, 628
 ,, ,, ,, ,, ,, leaflet of *Erythrina*, 629
 ,, ,, ,, ,, ,, leaflet of *Robinia*, 629
 ,, ,, ,, radial organs : *Lepidium*, 608
 ,, ,, ,, ,, ,, *Sinapis*, 593, 609
 ,, ,, ,, ,, ,, tendril of *Passiflora*, 611
 ,, ,, ,, ,, ,, *Vitis*, 611
- Recorder, 588-591
- response, definition of positive and negative, 581
 ,, intensity of stimulus on, 608, 609
 ,, modifying action of anisotropy and conductivity on, 608, 613, 628
 ,, multiple, 303, 584, 604, 634
 ,, ,, merging into continuous, 586
 ,, positive, negative, and dia-, 609
 ,, seasonal variation of, 602, 623
 ,, torsional, 659, 661

- Heliotropic sensitiveness, localisation of, 604, 650
 „ „ supposed absence of, in organs, 610
 Heliotropism, theory of Darwin, 582
 „ „ de Candolle, 580
 Hydraulic model, 31
 „ response, 363
 Hydrogen, effect of, on mechanical response, 131
 Hydrostatic disturbance, effect on electric response, 35
 „ „ „ mechanical response, 24
 „ *versus* true excitatory effect, 35, 47
- INDIA-RUBBER, contractile response of, 12
 „ fatigue-reversal of, 120
 Indicator diagram, 2
 Inner stimuli cause of growth, 421
 „ „ derived from external, 355
 Inorganic response, 12, 13, 40, 118
 „ „ abolition of, by poison, 40
 „ „ fatigue in, 119, 120
 „ „ staircase effect in, 121
 Internal energy, 308
 „ „ antagonistic action of, and external stimulus, 403
 „ „ effect of, on amplitude of pulsation, 338
 „ „ „ on frequency, 338
 „ „ a factor of recovery, 401
 „ „ spontaneous movement initiated by excess of, 305, 306
 „ „ tonic condition dependent on, 308, 314
Ipomoea, torsional response of, 670
 Isometric record, 25
 Isotonic record, 25
 Ivy, seasonal variation of heliotropic sensibility of, 623
 „ variation of electrical response by temperature, 141
- JENNINGS on chemotaxis of protozoa, 699
- KAT-ELECTROTONUS, 235
 Kathode, effect of, on growth, 556
 „ excitatory effect of, 192-197
 Kuhne on polar excitation of protozoa, 200
 Kunchangraph, 71
- LAMINA not perceptive organ, 60, 588, 650, 651
 Latent period, diminution of, by strong stimulus, 271
 „ „ in *Mimosa*, 22, 268
 „ „ prolongation of, by cold, 141, 268
 „ „ „ by fatigue, 269
 Lateral geotropism, 672
 „ response, general absence of, in radial organs, 50
 „ „ necessary conditions for, 44, 48

Laws of electrical response, 42

- „ growth, 439
- „ growth-curvature, 535
- „ mechanical response, 51
- „ polar action of currents, 199, 207, 558
- „ torsional response, 662

Leaves, dia-heliotropism of, 640

- „ drooping of, by frost, 400
- „ response in ordinary, 61

Lepidium, heliotropic response of, 608

Light, action of, on autonomous torsion, 669

- „ „ on longitudinal growth, 572, 573, 574
- „ „ on non-growing radial organ, 571
- „ „ on pulsation of *Desmodium*, 690, 691
- „ „ on pulvinate organ, 570
- „ „ on subtonic tissue, 569
- „ anisotropy induced by, 84
- „ directive *versus* non-directive action of, 634
- „ diverse movements induced by, 565
- „ effect on periodic reversals, 692
- „ induction of torsion by, 659
- „ multiple response induced by, 303, 584, 604, 634
- „ orientating action of, 587, 697
- „ supposed specific differences in the action of, 567
- „ transmitted action of, 606

Light and gravitation, incomplete analogy between the actions of, 597

See *Heliotropic response*

Longitudinal response in india-rubber, 12

- „ „ in muscle, 12
- „ „ in plants, 13, 76-80

Lysimachia Nummularia, heliotropic response of, 622, 624

Mangifera ndica, response of, 653

Marchantia hallus, action of light on, 622

Mechanical response, by curling, 91

- „ „ by uncurling, 89
- „ „ effect of chemical agents on, 131-137
- „ „ „ temperature on, 142-146
- „ „ favourable conditions for exhibition of, 48
- „ „ of *Allium* peduncle, 87
- „ „ of *Artocarpus*, 55
- „ „ of *Biophytum*, see *Biophytum*.
- „ „ of *Mimosa*, see *Mimosa*.
- „ „ of ordinary leaves, 61, 653, 654
- „ „ similarity of, in pulvinus, pulvinoid and growing organ, 534
- „ „ to artificial turgidity-variation, 45
- „ „ to suctional activity, 399
- „ „ two types of, 46

Michelia Champaca, chemotropic response of, 548

- Michelia Champaca*, galvanotropic response of, 559
 Microscope Recorder, 599
Mimosa, death-point of, 153
 „ duplication of rigor-point in, 179
 „ effect of anæsthetics on excitability of, 135
 „ „ darkness on the sensibility of, 22, 50
 „ „ electrotonus on excitability of, 235
 „ „ ether on conductivity of, 229
 „ „ excessive turgor on the sensibility of, 49
 „ „ fatigue on response of, 109
 „ erectile response of, to suction, 426
 „ excitatory *versus* plasmolytic reaction, 551, 552
 „ fatigue-reversal in, 109, 113, 114
 „ magnification of response of, 51
 „ mechanical response of, 21, 22, 268
 „ nyctitropic movement of, 681
 „ polar effects on, 194, 197, 204, 208, 210
 „ response of, to artificial variation of turgor, 46
 „ „ to direct stimulation, 531
 „ „ to electric radiation, 619
 „ „ to indirect stimulation, 532
 „ „ to light, 631, 632
 „ „ to salt solution, 551, 552
 „ thermic-mechanical record of, 172
 „ torsional response of, 658, 659
 Mohl on heliotropic insensitiveness of certain tendrils, 611
 Molecular model, 217
 Mono-polar method, 193
 Morograph, 167
 Motile areas in *Artocarpus*, 59
 „ excitability, earlier abolition than conductivity, 112
 „ „ effect of anæsthetics on, 229
 „ „ *versus* conductivity, 227, 228, 229
 „ „ „ receptivity, 226
 Multiple response to constant stimulus : in inorganic substance, 39, 575
 „ „ „ „ in plant, 300, 301, 302, 303, 574, 604
 „ „ „ „ in retina, 301
 „ „ to strong stimulus : electrical, 279
 „ „ „ „ electro tactile, 280
 „ „ „ „ mechanical, 283
 „ „ „ „ visual, 286
 „ „ comparison of various types of, 432
 „ „ continuity of, with autonomous, 291
 „ „ cyclic variation of, in *Biophytum*, 285
 „ „ „ „ in frog's heart, 351
 „ „ „ „ in growth, 417, 424
 „ „ „ „ in visual impulse, 288
 „ „ induction of, by light, 303, 584, 604, 634
 „ „ merging of, into continuous, 586

Musa paradisiaca, response of, 68, 616

Muscarin, effect of, on cardiac pulsation, 4

NECTAR, excretion of, 398

Nemèc on statolith theory, 494

Noll on anomalous plasmolytic movement, 550

Nyctitropic movement, of *Biophytum* petiole, 680

„ „ of *Mimosa* petiole, 681

„ „ supposed distinction between heliotropic and, 677

OLD tissues, excitatory reaction in, 57

Oltmanns on heliotropic response of *Lepidium*, 608

Optic Lever Recorder, 5

Oryza sativa, direct and indirect effects of stimulus on, 463

„ „ diurnal variation of growth of, 473

„ „ effect of electrification of soil on growth of, 560

Osmotic *versus* excitatory action : on ascent of sap, 383

„ „ „ „ on growth, 485

„ „ „ „ on mechanical response, 549, 550, 551, 552

Oxalis, diurnal sleep of, 633

PARA-HELIOtropISM, 621

Paramacia, chemotaxis of, 699

„ galvanotaxis of, 698

„ thermotaxis of, 698

Particles, response to unilateral pressure of, 496

Passiflora, death-discoloration of petals of, 183

„ effect of age on response, 79

„ „ season on response, 80

„ response of filament, 78

„ „ tendril, 89, 611

„ writhing movement of tendril of, 92

Perceptive region, of *Artocarpus* leaf, 60

„ „ of *Desmodium* leaflet, 588, 650

„ „ of leaflet of *Erythrina indica*, 651

„ „ true, 544

„ *versus* responding organ, 542, 588

Periodic after-effect, 683, 685

„ „ factors determining, 468

„ fatigue, 108

„ groupings : of growth-pulsation, 417, 425

„ „ of mechanical response, 286

„ reversals in *Desmodium* under light, 692

„ variation of *Desmodium* pulsation, 341, 470

„ „ of growth-rate, 470, 473, 474

„ „ of transpiration, 472

Pertz, D., on influence of alternating stimulation, 684

Pfeffer on action of light, 566

„ on chemo-taxis, 599

- Pfeffer on effect of light on autonomous response, 690
 „ on excitatory contraction in *Cynerca*, 69
 „ on expulsion of water from excited pulvinus of *Mimosa*, 254
 „ on geotropic sensitiveness of root-tip, 542
 „ on radial pressure theory of geotropism, 494
 Pflüger on law of polar excitation in animal tissue, 200
Philanthus urinaria, response of, 44, 271
 Photonasty, 621
 Phototaxis, 696
 Physical phenomena, merging of, into chemical, 122
 Plagiotropic stem, daily periodic movement of, 627
 „ „ response of, to light, 624, 625, 626
 „ „ „ to thermal shocks, 85
 Plant-chamber, 16
 Plasmolytic action, anomalous, 549
 Poison, abolition of inorganic response by, 40
 „ effect of, on autonomous pulsation, 326
 „ „ on growth, 486
 „ „ on mechanical response, 132
 „ „ on suctional response, 386
 „ modifying action of constitution on the effect of, 322, 487
 „ opposite effects of dose on action of, 488
 Polar action of currents : effect of fatigue on, 208
 „ „ „ „ high E.M.F., 207
 „ „ „ „ low E.M.F., 195
 „ „ „ „ moderate E.M.F., 197
 „ „ „ indirect effect of, 558
 „ „ „ laws of, in plant, 199, 207, 558
 „ „ „ localised effect of, on pulvinus, 554
 „ effects of currents : localised action on pulvinus, 554
 „ „ „ on death-response, 186, 207
 „ „ „ on glow-response, 211
 „ „ „ on growth, 557, 558, 559, 560
 „ „ „ on mechanical response, 193-206
Porana paniculata, autonomous torsional response of, 670
 Pressure, internal hydrostatic : irregular variation of, 395
 „ „ „ positive and negative, 393
 Protozoa, polar effects in, 205
 Pseudo-conduction, 251
 Pulsation, discrete nature of, in *Desmodium*, 340, 341, 431
 „ intermittent human, 288
 „ „ in *Biophytum*, 289
 Pulse, healthy adult and senile, 3
 „ human, nitrite of amyl on, 4
 Pulvinus and pulvinoid, 54

 RADIATION, discrimination from temperature effect, 615
 „ effect of electric, on *Mimosa*, 619
 „ „ thermal, 615-617

- Receptivity, variation of, 461
 „ „ by anaesthetics, 224
 „ *versus* conductivity, 226
- Recorder, Crescographic, 414, 416
 „ Demonstration, 6
 „ Electrical, 33
 „ Magnetically controlled, 568-588
 „ Microscopic, 519
 „ Optic Lever, 6, 16
 „ Spiral-Spring, 26
 „ Suctional, 340
- Recti-petality, theory of, 593
- Refractory period, 246, 273
- Regional death, thermographs of, 183-186
- Relaxation, anomalous meaning of, 339
- Response, different types of, 123
 „ identity of, in mature and growing organ, 435
 „ relation of, to stimulus, 95, 96, 97
 „ similarities of, between motile and growing organs, 437
 See *Chemotactic-*, *Chemotropic-*, *Death-*, *Differential-*, *Galvanotactic-*, *Galvanotropic-*, *Geotropic-*, *Growth-*, *Heliotropic-*, *Inorganic-*, *Mechanical-*, *Phototropic-*, and *Suctional-*.
- Responsiveness in matter, universality of, 40
- Retina, multiple excitation of, 286
- Rhythmic tissue, similarity of response in plant and animal, 345, 346, 348, 353
- Rhythmicity, cause of, 309
- Rigor, duplication of, 178
- Rigor mortis*, 153
- Robinia*, diurnal sleep movement of, 628
- Root and shoot, no polar difference between, 512
 „ difference of effect between excitation at tip or growing region, 513
 „ electric response, on direct stimulation of growing region, 518
 „ „ „ on stimulation of tip, 517
- Root-tip, effect of amputation of, on excitability, 540
 „ localisation of geotropic sensitiveness at, 539, 542
- SACHS on action of light on *Marchantia* thallus, 622
 „ on characteristic effects of light, 567
 „ on heliotropic response of *Tropaeolum majus*, 623
- Seasonal variation of conductivity and excitability, 474
 „ „ of contractility, 79
 „ „ of growth, 474
 „ „ of heliotropic response, 623
- Selenium, response of, 39
- Semi-automatism, 289
- Sensitiveness, abolition by over-turgidity, 58
 „ modification in darkness, 22, 50
 „ wide range in plants, 43
- Sesbania coccineum*, death-discoloration of, 183

- Shoshungraph, 364-371
 ,, record by Hydraulic Balance Method, 368
 ,, ,, Hydrostatic Balance Method, 368, 375
- Simultaneous mechanical and electrical records, 34
- Sinapis nigra*, effect of diffuse light on growth of, 572
 ,, ,, negative heliotropic response of root of, 601
 ,, ,, positive, dia-, and negative heliotropic response of, 609
 ,, ,, positive heliotropic response of seedling of, 592
- Sodium carbonate, effect of solution of, on growth, 481
 ,, chloride, effect of solution of, on growth, 484
 ,, ,, ,, ,, on mechanical response, 551
 ,, ,, ,, ,, on suction, 384
- Sphygmograph, 3
- Spirogyra*, thermo-mechanical curve of, 170
- Stahl on phototaxis, 697
- 'Staircase' response in galena, 121
 ,, ,, in muscle, 122
 ,, ,, in plant, 104, 121, 122
- Stimulation, direct effect of, on growth, 434, 435, 436, 438
 ,, ,, ,, on mechanical response, 47, 420
 ,, effect of unilateral direct, on growth-curvature, 527, 529
 ,, ,, ,, indirect, on growth-curvature, 525, 528, 529
 ,, indirect effect of, on growth, 438
 ,, ,, ,, on mechanical response, 47, 420
 ,, minimally effective, 26
 ,, ,, ,, variation of, at different temperatures, 27
- Stimulus, additive effect of, 94
 ,, and response, relation between, 95, 96, 97
 ,, ,, ,, ,, modified by tonic condition, 465
 ,, bifurcation of effect of, 127
 ,, detection of latent, 459
 ,, different modes of transformation of, 123-126
 ,, supposed explosive effect of, 454
- Strasburger on action of light on autonomous movements, 690
 ,, ,, of poison on ascent of sap, 351
 ,, ,, on phototaxis, 697
- Suction, automatic record of variation in the rate of, 371
 ,, internal pressure due to, 393, 394, 395
 ,, mechanical response to, 399
- Suctional response, effect of cold water on, 373, 376, 379
 ,, ,, ,, KNO₃ solution on, 383
 ,, ,, ,, NaCl solution on, 384
 ,, ,, ,, poisonous solution on, 386
 ,, ,, ,, warm water on, 375, 378, 380
 ,, ,, excitatory nature of, 382
 ,, ,, ,, *versus* plasmolytic action on, 383
 ,, ,, persistence of, when root killed, 381
- Sugar, chemotactic effect of, 699
 ,, chemotropic effect of, 549

Sugar, effect of solution on growth, 482

Sunflower, impressed periodic movement in, 685

Tamarindus indica, diurnal variation in the rate of growth of, 474

„ „ initiation of growth in, by stimulus, 425

„ „ response to thermal radiation, 617

Temperature and growth, relation between: determination by Continuous Method, 446

„ „ „ „ determination by Discontinuous Method, 442

„ „ „ „ determination by Method of Balance, 450

„ „ „ „ determination by Method of Excitatory Response, 452

„ and rhythmic frequency, relation between, 349

„ effect of maximum, on arrest of *Desmodium* pulsation, 432

„ „ „ on growth-arrest, 431

„ „ „ on cardiac pulsation, 333, 334

„ „ „ on *Desmodium* pulsation, 332-338

„ „ „ on intensity of minimally effective stimulus, 27

„ „ „ on latent period, 141, 268

„ „ „ on response, 140-146

„ optimum, of growth, 449, 451

„ variation, effect on growth, 615

Tesla current, effect of, on growth, 619

Tetanus in muscle, 98

„ in plant, 99

„ incapability of, in rhythmic tissue, 340

Thermal radiation, discrimination between effect of, and temperature, 615

„ „ growth-curvature induced by, 616, 617

Thermo-crescent curve, 447

Thermographs, development of, 184

„ of regional death, 183-186

Thermo-mechanical curve, 160

Thermo-taxis, 698

Thermo-tonic minimum in *Biophytum*, 305

„ „ in *Desmodium*, 305

Tip of root or shoot, electric response on stimulation of, 517, 518

„ „ mechanical response on stimulation of, 525, 526, 601, 606

„ effect on excitability on amputation of, 541

Tonic condition, modifying effect of, on relation between stimulus and response, 465

„ „ true meaning of, 307, 313

Torsion, autonomous, 666

„ „ effect of electric current on, 670

„ „ „ gravity on, 671

„ „ „ light on, 669

„ „ „ temperature on, 667

Torsional response, laws of, 662

„ „ of compound strip, 660

- Torsional response, of *Desmodium*, 657
 „ „ of *Erythrina indica*, 661
 „ „ of *Mimosa*, 658, 659
 Transmission of heliotropic excitation, 604
 Transpiration, automatic record of variation of, 371, 472
 „ effect of dissolved salt on, 383
 Transverse conduction of stimulation, 519, 528, 529, 532
Tropaeolum majus, heliotropic response in : seasonal variation of, 623
 „ „ „ „ variation of, with intensity of stimulus,
 623, 626
 Turgidity, positive and negative variation : electrical indication of, 37, 41
 „ „ „ „ induced changes of rate of growth by,
 426, 435
 „ „ „ „ mechanical indication of, 37, 41
 „ response by artificial, 45
- Ulothrix*, phototaxis of, 697
 Uniform response, 104
Uriclis Lily, apogeotropic response of scape of, 500, 505
 „ periodic fatigue in the response of style of, 108
- VARIATION, induction of, by external forces, 750
 Verworn on polar excitation of protozoa, 200
 Vines on autonomous epi- and hypo-nasty, 643
 „ on protoplasmic irritability, 53
 Vintschgau on velocity of nervous impulse, 246
 Visual impulse, multiple, 286, 300
 Vitalism, 740
Vitis, heliotropic response of tendril of, 611
 Vochting on theory of recti-petality, 594
- WATER, excretion of, 396

PRINTED BY
 SPOTTISWOODE AND CO. LTD., NEW-STREET SQUARE
 LONDON

